

**AGENDA**  
**ROCKY POINT PUBLIC SCHOOLS**  
**BOARD OF EDUCATION MEETING**  
**March 18, 2024**

**Reminder Regarding Public Comment:**

- Speakers must present their license to Mrs. Crossan as they approach the podium to allow for their address to be recorded. Speakers will announce their name once at the podium.
- Public comment at meetings of the Board shall be restricted to civil discourse, free from disparaging remarks or inferences toward any person or organization. Speakers who fail to observe this protocol will be ruled out of order.
- A period of time not to exceed fifteen (15) minutes, unless extended at any given meeting by resolution of the Board, shall be provided prior to Board action on the agenda. Each speaker shall be limited to a maximum of three minutes. Speakers may not share, defer, or otherwise reallocate any or all of the three minutes afforded them.
- A period of time not to exceed thirty (30) minutes, unless extended at any given meeting by resolution of the Board, shall be provided subsequent to the completion of Board action on the agenda. Each speaker shall be limited to a maximum of three minutes. Speakers may not share, defer, or otherwise reallocate any or all of the three minutes afforded them.
- Speakers shall be ruled out of order if they attempt to speak about any specific student or employee, by name or title.

**I Meeting called to Order:**

Present: Jessica Ward, President  
Michael Lisa, Vice President  
Edward Casswell, Trustee  
Susan Sullivan, Trustee  
Erin Walsh, Trustee  
Scott O'Brien, Ed.D., Superintendent of Schools  
Susann Crossan, Assistant Superintendent  
Christopher Van Cott, Assistant Superintendent for Business  
Aaron Factor Ed.D., Assistant Superintendent for Curriculum and Instruction  
Kelly White, District Clerk

Absent:

**II Executive Session**

At \_\_\_\_\_ p.m. motion made and seconded to adjourn to Executive Session to discuss \_\_\_\_\_.

Motion \_\_\_\_\_ 2<sup>nd</sup> \_\_\_\_\_ Vote \_\_\_\_\_

**The Board returned to Open Session at \_\_\_\_\_ p.m.**

**Pledge of Allegiance**

**Superintendent’s Report**

**CONSENT AGENDA**

The items listed below are presented as part of the Consent Agenda which can be adopted by the Board of Education under a single motion followed by a second and then a formal vote. On the following page the Consent Agenda items are listed in their regular order within a group. Before an actual vote is taken, any Consent Agenda item may be removed by a Board member without a formal motion or second. If this occurs, the indicated resolution will be discussed during its regular order on the agenda and voted on individually.

**III-VI Consent Agenda Items**

**BE IT RESOLVED**, that the Board of Education accepts the following agenda items as one item.

- III: Minutes** – Regular Meeting March 4, 2024, Executive Session March 7, 2024
- IV: Budget Transfer Summary** – February 2024
- V: Internal Claims Audit Report** – February 2024
- VI: Committees on Special Education Schedules 3-18-24-A and 3-18-24-B** as recommended by the Superintendent of Schools, to arrange for appropriate services, as indicated.

Motion\_\_\_\_\_2<sup>nd</sup>\_\_\_\_\_Vote\_\_\_\_\_

**VII Rocky Point PTA Donation of Funds for 6th Grade Field Trip**

**BE IT RESOLVED**, that upon the recommendation of the Superintendent of Schools, the Board of Education approves and accepts the donation from the Rocky Point PTA for funds towards the 6<sup>th</sup> grade field trip.

**BE IT RESOLVED**, that the Rocky Point Union Free School District hereby approves upon the recommendation of the Superintendent of Schools, to increase the general fund budget by \$218.00 as a result of the donation from The Rocky Point PTA.

**BE IT FURTHER RESOLVED**, that the following budget code be adjusted to reflect that increase:

A2110406060000 \$218.00

Motion\_\_\_\_\_2<sup>nd</sup>\_\_\_\_\_Vote\_\_\_\_\_

**VIII Surplus Equipment**

**BE IT RESOLVED**, that upon the recommendation of the Superintendent of Schools, the Board of Education approve for surplus the following attached list of equipment.

Motion\_\_\_\_\_2<sup>nd</sup>\_\_\_\_\_Vote\_\_\_\_\_

**IX Board of Education Review and Re-adoption of Board of Education Policy Number 3411 (Second Reading)**

**BE IT RESOLVED**, that upon the recommendation of the Superintendent of Schools, the Board of Education adopts the following revised policy (second reading):

3411 Prohibition of Weapons on School Grounds

Motion\_\_\_\_\_2<sup>nd</sup>\_\_\_\_\_Vote\_\_\_\_\_

**X Board of Education Review and Re-adoption of Board of Education Policy Number 5621 (Second Reading)**

**BE IT RESOLVED**, that upon the recommendation of the Superintendent of Schools, the Board of Education adopts the following revised policy (second reading):

5621 Accounting of Fixed Assets

Motion\_\_\_\_\_2<sup>nd</sup>\_\_\_\_\_Vote\_\_\_\_\_

**XI E-Rate Award: Internet Access and Wide Area Network (WAN) Services**

**BE IT RESOLVED**, that upon the recommendation of the Superintendent of Schools, the Board of Education approves the proposal for Internet Access and Wide Area Network (WAN) services to Eastern Suffolk BOCES, for a three (3) year term (7/1/2024 -6/30/2027) at a pre-discounted amount of \$19,332.00 per year. This cost does not include the ineligible project coordination fees of \$3,068.12 per year. The District will utilize funding through the E-rate program to cover an estimated 60% of said costs. Net cost paid to Eastern Suffolk BOCES by the District to be approximately \$7,732.80 per year.

Motion\_\_\_\_\_2<sup>nd</sup>\_\_\_\_\_Vote\_\_\_\_\_

**XII 2024-2025 BOCES Joint Municipal Cooperative Bidding Program**

**BE IT RESOLVED**, that upon the recommendation of the Superintendent of Schools, the Board of Education approves the Resolution to participate in the BOCES Cooperative Bidding , Purchasing Program for the 2024-2025 Fiscal Year on as "as needed" basis as per the Attached Joint Municipal Cooperative Bidding Program Resolution (A).

Motion \_\_\_\_\_ 2<sup>nd</sup> \_\_\_\_\_ Vote \_\_\_\_\_

**XIII Special Education Parent Choice Contract-Smithtown Central School District for 2023-24**

**BE IT RESOLVED**, that upon the recommendation of the Superintendent of Schools, the Board of Education authorizes the President of the Board of Education to enter into a contract with Smithtown Central School District for special education students' services at Smithtown Christian School and Harbor Country Day School for the 2023-24 school year, as required under applicable Individual Educational Programs, applicable law, and/or District Policy.

Motion \_\_\_\_\_ 2<sup>nd</sup> \_\_\_\_\_ Vote \_\_\_\_\_

**XIV 2023-2024 Health Service Contract-Center Moriches School District**

**BE IT RESOLVED**, that upon the recommendation of the Superintendent of Schools, the Board of Education authorizes the President of the Board of Education to enter into an agreement for health services for the 2023-2024 school year with the following district:

Center Moriches School District

Motion \_\_\_\_\_ 2<sup>nd</sup> \_\_\_\_\_ Vote \_\_\_\_\_

**XV Student Instructional Services Contract - A**

**BE IT RESOLVED**, that upon the recommendation of the Superintendent of Schools, the Board of Education approves and authorizes the Board of Education President to execute the Agreement between Rocky Point Schools and Mr. Trevor Roper for his daughter, Autumn Roper, grade 5, to attend Joseph A. Edgar Intermediate School for the 2023-2024 school year. Tuition on a non-precedential basis will be waived for the 2023-2024 School Year.

Motion \_\_\_\_\_ 2<sup>nd</sup> \_\_\_\_\_ Vote \_\_\_\_\_

**XVI Student Instructional Services Contract – B**

**BE IT RESOLVED**, that upon the recommendation of the Superintendent of Schools, the Board of Education approves and authorizes the Board of Education President to execute the Agreement between Rocky Point Schools and Mrs. Kristen Gunning for her daughter, Allison Gunning, grade 12, to attend Rocky Point High School for the 2023-2024 school year. Tuition on a non-precedential basis will be waived for the 2023-2024 School Year.

Motion \_\_\_\_\_ 2<sup>nd</sup> \_\_\_\_\_ Vote \_\_\_\_\_

**XVII State Environmental Quality Review Act (SEQRA)/2024-25 Capital Program**

**WHEREAS**, the Board of Education of the Rocky Point Union Free School District desires to embark upon the following capital improvement projects:

- **FRANK J. CARASITI ES:**
  - EXTERIOR DOORS/SECURITY GLASS FILM INSTALLATION
  - INTERIOR DOOR AND HARDWARE REPLACEMENT
- **JOSEPH A. EDGAR INTERMEDIATE SCHOOL:**
  - EXTERIOR DOORS/SECURITY GLASS FILM INSTALLATION
- **MIDDLE SCHOOL/HIGH SCHOOL:**
  - EXTERIOR DOORS/SECURITY GLASS FILM INSTALLATION
  - MS GYM BLEACHER REPLACEMENT
  - VCT REPLACEMENT

(the “Projects”); and

**WHEREAS**, said capital improvements are subject to classification under the State Environmental Quality Review Act (SEQRA); and

**WHEREAS**, maintenance or repair involving no substantial changes in an existing structure or facility are classified as Type II Actions under the current Department of Environmental Conservation SEQRA Regulations (Section 6 NYCRR 617.5 (c)(1)); and

**WHEREAS**, replacement, rehabilitation or reconstruction of a structure or a facility, in kind, on the same site, including upgrading buildings to meet building or fire codes, unless such action meets or exceeds any of the thresholds in section 617.4 are classified as Type II Actions under the current Department of Environmental Conservation SEQRA Regulations (Section 6 NYCRR 617.5 (c)(2)); and

**WHEREAS**, the SEQRA Regulations declare Type II Actions to be actions that have no significant impact on the environment and require no further review under SEQRA; and

**WHEREAS**, the Board of Education, as the only involved agency, has examined all information related to the capital improvement projects and has determined that the Project is classified as a Type II Action pursuant to Section 617.5(c)(1) and (2) of the SEQRA Regulations;

**NOW, THEREFORE, BE IT RESOLVED**, that the Board of Education hereby declares itself lead agency in connection with the requirements of the State Environmental Quality Review Act; and

**BE IT FURTHER RESOLVED**, that the Board of Education, after a review of the proposed action, hereby declares that the Projects are Type II Actions, which requires no further review under SEQR; or

**BE IT FURTHER RESOLVED**, that the Board of Education hereby shall forward an official copy of this Resolution to the New York State Education Department together with a copy of the correspondence from the New York State Office of Parks, Recreation and Historic Preservation in connection with its request for approval of the listed project from the New York State Education Department.

Motion \_\_\_\_\_ 2<sup>nd</sup> \_\_\_\_\_ Vote \_\_\_\_\_

**XVIII Personnel**

**BE IT RESOLVED**, that upon the recommendation of the Superintendent of Schools, the Board of Education accepts the attached Personnel changes.

Motion \_\_\_\_\_ 2<sup>nd</sup> \_\_\_\_\_ Vote \_\_\_\_\_

**XIX New Business**

**XX Executive Session (if necessary)**

At \_\_\_\_\_ PM, a motion was made by \_\_\_\_\_ and seconded by \_\_\_\_\_ to go into Executive Session to discuss \_\_\_\_\_.

Motion \_\_\_\_\_ 2<sup>nd</sup> \_\_\_\_\_ Vote \_\_\_\_\_

**XXI Adjournment**

I move that the Board of Education adjourns the meeting at \_\_\_\_\_ PM

Motion \_\_\_\_\_ 2<sup>nd</sup> \_\_\_\_\_ Vote \_\_\_\_\_

**AGENDA**  
**ROCKY POINT PUBLIC SCHOOLS**  
**BOARD OF EDUCATION MEETING**  
**March 4, 2024**

The meeting was called to order at 5:01 p.m. in the auditorium of Rocky Point High School.

Present: Jessica Ward, President  
Michael Lisa, Vice President  
Edward Casswell, Trustee  
Erin Walsh, Trustee (Arriving at 5:03 p.m.)  
Scott O'Brien, Ed.D., Superintendent of Schools  
Susann Crossan, Assistant Superintendent  
Christopher Van Cott, Assistant Superintendent for Business  
Kelly White, District Clerk

Absent: Susan Sullivan, Trustee  
Aaron Factor Ed.D., Assistant Superintendent for Curriculum and Instruction

**EXECUTIVE SESSION**

At 5:01 p.m. a motion was made by Michael Lisa, and seconded by Ed Casswell, to adjourn to Executive Session to discuss confidential personnel and legal matters.

All in favor – Motion carried 3-0

At 5:58 p.m. a motion was made by Erin Walsh, and seconded by Michael Lisa, to adjourn Executive Session in order to attend the Budget Workshop presented by Mr. Christopher Van Cott.

All in favor – Motion carried 4-0

**PLEDGE OF ALLEGIANCE**

At 6:22 p.m., upon completion of the Budget Workshop, a motion was made by Ed Casswell, and seconded by Michael Lisa, to continue their discussions regarding confidential legal and personnel matters.

All in favor – Motion carried 4-0

The Board returned to Open Session at 7 p.m.

**PLEDGE OF ALLEGIANCE**

Ms. Ward reminded the meeting attendees of the public comment procedure.

## **SUPERINTENDENT'S REPORT**

Dr. O'Brien thanked Mr. Van Cott for his budget presentation. He also expressed his appreciation to Mr. Van Cott and the Board of Education members for their hard work in establishing the budget. Dr. O'Brien reminded the meeting attendees that the next presentation would occur on March 18, 2024.

Dr. O'Brien congratulated the Rocky Point coaches and cheer team on their National Championship title. He added that they would be recognized at the May 21, 2024 Board of Education meeting along with the other sports and academic recognitions.

Ms. Ward opened the floor to questions/comments regarding the agenda.

There were no questions/comments.

## **CONSENT AGENDA**

The items listed below are presented as part of the Consent Agenda which can be adopted by the Board of Education under a single motion followed by a second and then a formal vote. On the following page the Consent Agenda items are listed in their regular order within a group. Before an actual vote is taken, any Consent Agenda item may be removed by a Board member without a formal motion or second. If this occurs, the indicated resolution will be discussed during its regular order on the agenda and voted on individually.

### **III-IX CONSENT AGENDA ITEMS**

Upon a motion made by Michael Lisa, and seconded by Erin Walsh, the following resolution was offered:

**BE IT RESOLVED**, that the Board of Education accepts the following agenda items as one item.

- III: Minutes** – Regular Meeting February 5, 2024
- IV: Budget Transfer Summary** – January 2024
- V: Treasurer's Reports** – January 2024
- VI: Extra-Classroom Activity Account Treasurer's Report** – January 2024
- VII: Financials** - January 2024
- VIII: Internal Claims Audit Report** – January 2024
- IX: Committees on Special Education Schedules 3-4-24-A and 3-4-24-B** as recommended by the Superintendent of Schools, to arrange for appropriate services, as indicated.

All in favor – Motion carried 4-0



**X DONATION OF GOLF CLUBS (2 SETS) AND GOLF ORGANIZER**

Upon a motion made by Erin Walsh, and seconded by Ed Casswell, the following resolution was offered:

**BE IT RESOLVED**, that upon the recommendation of the Superintendent of Schools, the Board of Education accepts the two (2) sets of Wilson golf clubs and a golf organizer, valued at approximately \$400.00 and \$100 respectively, totaling \$500.00 from parent, Maureen Montanaro.

All in favor – Motion carried 4-0

Ms. Ward thanked Ms. Montanaro for her generous donation.

**XI DONATION FROM OHIOPYLE PRINTS, INC.**

Upon a motion made by Ed Casswell, and seconded by Michael Lisa, the following resolution was offered:

**BE IT RESOLVED**, that upon the recommendation of the Superintendent of Schools, the Board of Education approve and accept the donation from Ohiopyle Prints, Inc.

**BE IT RESOLVED**, that the Rocky Point Union Free School District hereby approves upon the recommendation of the Superintendent of Schools, to increase the general fund budget by \$97.94 as a result of the donation from Ohiopyle Prints, Inc.

**BE IT FURTHER RESOLVED**, that the following budget code be adjusted to reflect that increase:

A2110500030000 \$97.94

All in favor – Motion carried 4-0

Ms. Ward thanked Ohiopyle for their donation.

**XII FRIENDS OF MUSIC DONATION FOR JAZZ BAND CLINIC**

Upon a motion made by Michael Lisa, and seconded by Erin Walsh, the following resolution was offered:

**BE IT RESOLVED**, that upon the recommendation of the Superintendent of Schools, the Board of Education approve and accept the donation from The Friends of Music for High School and Middle School jazz band students to attend a jazz clinic, workshop and tour of The Jazz Loft.

**BE IT RESOLVED**, that the Rocky Point Union Free School District hereby approves upon the recommendation of the Superintendent of Schools, to increase the general fund budget by \$1,200.00 as a result of the donation from The Friends of Music.

**BE IT FURTHER RESOLVED**, that the following budget code be adjusted to reflect that increase:

A2138 436 03 3120 \$1,200.00

All in favor – Motion carried 4-0

Ms. Ward thanked the Friends of Music for the opportunity for the students to attend this great event.

**XIII LIVE LIKE SUSIE DONATION**

Upon a motion made by Erin Walsh, and seconded by Ed Casswell, the following resolution was offered:

**BE IT RESOLVED**, that upon the recommendation of the Superintendent of Schools, the Board of Education approves and accepts the donation on behalf of the Live Like Susie Scholarship, totaling \$100.00, as follows:

Robert/Elizabeth Lauritsen, \$100.00

All in favor – Motion carried 4-0

Ms. Ward thanked the Lauritsen family for their donation.

**XIV DONATION OF TWO PITCHING MACHINES - ROCKY POINT ATHLETIC BOOSTER CLUB**

Upon a motion made by Ed Casswell, and seconded by Michael Lisa, the following resolution was offered:

**BE IT RESOLVED**, that upon the recommendation of the Superintendent of Schools, the Board of Education accepts the donation of two (2) hack attack pitching machines from the Rocky Point Athletic Booster Club, valued at approximately \$3,750.00 each, totaling \$7,500.00.

All in favor – Motion carried 4-0

Ms. Ward thanked the Booster Club for their generous donation.

**XV BOARD OF EDUCATION REVIEW AND RE-ADOPTION OF BOARD OF EDUCATION POLICY NUMBER 3411 (FIRST READING)**

Upon a motion made by Michael Lisa, and seconded by Erin Walsh, the following resolution was offered:

**BE IT RESOLVED**, that upon the recommendation of the Superintendent of Schools, the Board of Education adopts the following revised policy (first reading):

3411 Prohibition of Weapons on School Grounds

All in favor – Motion carried 4-0

**XVI BOARD OF EDUCATION REVIEW AND RE-ADOPTION OF BOARD OF EDUCATION POLICY NUMBER 5621 (FIRST READING)**

Upon a motion made by Erin Walsh, and seconded by Ed Casswell, the following resolution was offered:

**BE IT RESOLVED**, that upon the recommendation of the Superintendent of Schools, the Board of Education adopts the following revised policy (first reading):

5621 Accounting of Fixed Assets

All in favor – Motion carried 4-0

**XVII BOARD OF EDUCATION ADOPTION OF BOARD OF EDUCATION POLICY NUMBER 6191 (SECOND READING)**

Upon a motion made by Ed Casswell, and seconded by Michael Lisa, the following resolution was offered:

**BE IT RESOLVED**, that upon the recommendation of the Superintendent of Schools, the Board of Education adopts the following policy (second reading):

6191 Workplace Violence Prevention

All in favor – Motion carried 4-0

**XVIII BOARD OF EDUCATION REVIEW AND RE-ADOPTION OF BOARD OF EDUCATION POLICY NUMBER 7350 (SECOND READING)**

Upon a motion made by Michael Lisa, and seconded by Erin Walsh, the following resolution was offered:

**BE IT RESOLVED**, that upon the recommendation of the Superintendent of Schools, the Board of Education adopts the following revised policy (second reading):

7350 Corporal Punishment

All in favor – Motion carried 4-0

**XIX BOARD OF EDUCATION REVIEW AND ADOPTION OF BOARD OF EDUCATION POLICY NUMBER 7351 (SECOND READING)**

Upon a motion made by Erin Walsh, and seconded by Ed Casswell, the following resolution was offered:

**BE IT RESOLVED**, that upon the recommendation of the Superintendent of Schools, the Board of Education adopts the following policy (second reading):

7351 Use of Emergency Interventions

All in favor – Motion carried 4-0

**XX BOARD OF EDUCATION ADOPTION OF BOARD OF EDUCATION POLICY NUMBER 7441 (SECOND READING)**

Upon a motion made by Ed Casswell, and seconded by Michael Lisa, the following resolution was offered:

**BE IT RESOLVED**, that upon the recommendation of the Superintendent of Schools, the Board of Education adopts the following policy (second reading):

7441 Student Voter Registration and Pre-Registration

All in favor – Motion carried 4-0

**XXI BID #24-01 IN-CAR DRIVER EDUCATION CONTRACT  
EXTENSION FOR 2024-25**

Upon a motion made by Michael Lisa, and seconded by Erin Walsh, the following resolution was offered:

**BE IT RESOLVED**, that upon the recommendation of the Superintendent of Schools, the Board of Education renew the agreement with Suffolk Auto Driving School for the 2024-25 fiscal year at no additional cost, as per the attached.

All in favor – Motion carried 4-0

**XXII SHOREHAM-WADING RIVER CSD 2023-2024 SCHOOL YEAR  
CONTRACT**

Upon a motion made by Erin Walsh, and seconded by Ed Casswell, the following resolution was offered:

**BE IT RESOLVED**, that upon the recommendation of the Superintendent of Schools, the Board of Education authorizes the President of the Board of Education to enter into a contract with Shoreham-Wading River Central School District for special education students' instructional services for the 2023-2024 school year as required under applicable Individual Educational Programs, applicable law, and/or District Policy.

All in favor – Motion carried 4-0

**XXIII 2023-2024 HEALTH SERVICE CONTRACT-SMITHTOWN  
CENTRAL SCHOOL DISTRICT**

Upon a motion made by Ed Casswell, and seconded by Michael Lisa, the following resolution was offered:

**BE IT RESOLVED**, that upon the recommendation of the Superintendent of Schools, the Board of Education authorizes the President of the Board of Education and the Superintendent of Schools to enter into an agreement for health services for the 2023-2024 school year with the following districts:

Smithtown Central School District

All in favor – Motion carried 4-0

**XXIV ANNUAL MEETING (BUDGET VOTE AND TRUSTEE ELECTION)**

Upon a motion made by Michael Lisa, and seconded by Erin Walsh, the following resolution was offered:

**BE IT RESOLVED**, that the Annual Meeting (Budget Vote and Trustee Election) of the Rocky Point Union Free School District, Town of Brookhaven, Suffolk County, New York be conducted on Tuesday, May 21, 2024 from 7:00 A.M. to 9:00 P.M., and further

**BE IT RESOLVED**, that pursuant to Section 2017 of the Education Law, a Public Hearing for the purpose of discussion of the expenditure of funds and the budgeting thereof be held at 5:00 PM on May 7, 2024 at the Rocky Point High School, Rocky Point, New York and further

**BE IT RESOLVED**, that the Legal Notice of the Public Hearing and Annual Meeting, as required by law, be published in the *LONG ISLAND BUSINESS NEWS*, on April 5, April 19, May 3 and May 17 and in *THE VILLAGE BEACON RECORD* on April 4, April 18, May 2 and May 16 and further

**BE IT RESOLVED**, that the Legal Notice of the Annual Meeting (Budget Vote and Trustee Election), as required by law, be published in the *LONG ISLAND BUSINESS NEWS*, April 5, April 19, May 3 and May 17 and in *THE VILLAGE BEACON RECORD* on April 4, April 18, May 2 and May 16 and further

**BE IT RESOLVED**, that the following location is hereby designated as the polling place:

Rocky Point High School Gymnasium; and further

**BE IT RESOLVED**, that the Board of Education, in addition to the legal publication in four editions of each of the two above-mentioned newspapers, will send a notice with all information relative to the date and time of the vote and election to all residents within the District, and further

**BE IT RESOLVED**, that the residents of the Rocky Point Union Free School District may register to vote for School District Meetings at the office of the District Clerk between the hours of 9:00 AM and 3:00 PM on any day that the office is open, and on the evening of May 14, 2024 until 9:00 PM. However, such registration may not take place less than five (5) days preceding any School District Meeting, and further

**BE IT RESOLVED**, that the District Clerk is authorized to assign the necessary personnel to function as Election Inspectors, and further

**BE IT RESOLVED**, that the final tally of votes shall be held at the Rocky Point High School, 82 Rocky Point-Yaphank Road, Rocky Point, New York at 9:00 PM on the evening of the election as soon thereafter as the election inspectors can certify as to the necessary information.

All in favor – Motion carried 4-0

**XXV APPOINTMENT OF POLL CLERKS AND TELLERS FOR THE ANNUAL BUDGET VOTE AND ELECTION TO BE HELD ON MAY 21, 2024**

Upon a motion made by Erin Walsh, and seconded by Ed Casswell, the following resolution was offered:

**BE IT RESOLVED** that the Board of Education appoints the Board of Registration; Poll Clerks; Tellers and Substitute Poll Clerks and Tellers at an hourly rate of \$16.00.

**BE IT ALSO RESOLVED**, that the District Clerk is authorized to canvass individuals to serve as Poll Clerks/Tellers and Substitute Poll Clerks/Tellers for the Annual Budget Vote and Board of Education Election to be held on Tuesday, May 21, 2024, during the hours of 7:00 a.m. and 9:00 p.m. and is authorized to fill any vacancies in these positions which may occur before such date.

All in favor – Motion carried 4-0

**XXVI SETTLEMENT AGREEMENT**

Upon a motion made by Ed Casswell, and seconded by Michael Lisa, the following resolution was offered:

**RESOLVED**, that the Board of education President is authorized to execute the confidential Agreement between the District and Rocky Point UFSD Employee # 1437 on the matter of resignation.

All in favor – Motion carried 4-0

**XXVII PERSONNEL**

Upon a motion made by Michael Lisa, and seconded by Erin Walsh, the following resolution was offered:

**BE IT RESOLVED**, that upon the recommendation of the Superintendent of Schools, the Board of Education accepts the attached Personnel changes.

All in favor – Motion carried 4-0

Ms. Ward congratulated the following employee on their appointment:

- Ms. Stephanie Katz – School Hall Monitor - HS

**XXVIII NEW BUSINESS**

Ms. Ward inquired of the trustees if there was any new business they wished to discuss.

There was no new business at this time.

Ms. Ward once again opened the floor to questions/comments.

- Ms. Johnson, President of the RP Historical Society & Homestead Museum, thanked Mr. Van Cott for his clear budget presentation. She inquired about the deadline to submit a proposition to the voters as well as the required number of signatures. Mr. Van Cott advised that (35) signatures would be required and stated he would get back to her regarding the deadline for submission. Ms. Ward advised the audience that the reason the Historical Society is asking these questions is that they want us to put a proposition on our ballot for May that would result in a tax to district residents. The Board is still looking into the legality of their ask and the item is still being discussed.
- Mr. McNamara from the RP Rotary Club announced that the establishment of a Corridor of Peace had been approved, making our community the 402<sup>nd</sup> Community of Peace in the world. Mr. McNamara thanked the Board of Education for their support. He also thanked the Drama department for their outstanding presentation of the Adams Family.
- Ms. Polanco spoke on behalf of a former employee and urged for reconsideration of the decision. She described him as a respectful role model with a passion for teaching and an asset to the District.
- Mr. Reisinger spoke on behalf of a former employee and urged for reconsideration of the decision. He described him as a mentor and spoke of the positive impact he has had on the students.
- Miss M. Blaising spoke on behalf of a former employee and urged for reconsideration of the decision. She described him as a wonderful teacher and coach with a good conscience and stated he would be missed.
- Mr. Amayo spoke on behalf of a former employee and urged for reconsideration of the decision. He described him as good man.
- Mister G. Marmol spoke on behalf of a former employee and urged for reconsideration of the decision. He described him as a role model and someone who believed in him.
- Mister P. Reisinger spoke on behalf of a former employee and urged for reconsideration of the decision. He described him as someone that provided principles that he could apply to everyday life.
- Mister L. Parker spoke on behalf of a former employee and urged for reconsideration of the decision. He described him as impactful, and someone who pushed him to be better.
- Mister D. Colon spoke on behalf of a former employee and urged for reconsideration of the decision. He described him as a big brother figure who would reach out outside of school and push him to succeed.
- Ms. Behringer spoke on behalf of a former employee and urged for reconsideration of the decision. She described him as dedicated, professional, patient, resilient and impactful.
- Ms. Jablonski spoke on behalf of a former employee and urged for reconsideration of the decision. She described him as someone who has the ability to bring people together.

At 7:46 p.m., upon a resolution by Michael Lisa, and seconded by Erin Walsh, it was approved to extend the public comment portion of the meeting for another (30) minutes.

All in favor – Motion carried 4-0

- Ms. DeRosa spoke on behalf of a former employee and urged for reconsideration of the decision. She described it as a true testament to his character based on the number of people showing support for him.
- Miss Madelyn (student) spoke on behalf of a former employee and urged for reconsideration of the decision. She expressed feeling safe around him and added that his absence leaves an empty space.
- Mister N. Moore spoke on behalf of a former employee and urged for reconsideration of the decision. He described him as taking the time to help and teaching valuable life lessons.
- Mister M. Blaising spoke on behalf of a former employee and urged for reconsideration of the decision. He described him as a blessing to work with and someone that promotes confidence.
- Mr. Polanco spoke on behalf of a former employee and urged for reconsideration of the decision. He described him as an impactful role model in a time where role models are scarce.
- Mister Q. Palifka spoke on behalf of a former employee and urged for reconsideration of the decision. He described him as impactful and someone who is all about the students.
- Mister J. Concessi spoke on behalf of a former employee and urged for reconsideration of the decision. He described him as a great man with an impact who made you feel protected.
- Mister M. Williams spoke on behalf of a former employee and urged for reconsideration of the decision. He described him as an inspiring man with a military background.
- Mr. Castro spoke on behalf of a former employee and urged for reconsideration of the decision. He described him as a veteran with impeccable character.
- Ms. Hanley spoke on behalf of a former employee and urged for reconsideration of the decision. She spoke of his enthusiasm and positivity.
- Mister J. Nadeau spoke on behalf of a former employee and urged for reconsideration of the decision. He described him as impactful man that taught valuable lessons.
- Ms. Blaising spoke on behalf of a former employee and urged for reconsideration of the decision. She described him as someone who went above and beyond and taught students to earn what they received.
- Mister E. Watkis spoke on behalf of a former employee and urged for reconsideration of the decision. He described him as someone who made an effort to make a connection.
- Mister P. Logan spoke on behalf of a former employee and urged for reconsideration of the decision. He described him as an impactful role model.



- Ms. Lucian spoke on behalf of a former employee and urged for reconsideration of the decision. He described him as someone who deserves a second chance.
- Mr. Cascione spoke on behalf of a former employee and urged for reconsideration of the decision. He described him as a fair, honest role model and noted that it would be a loss for the school.
- Ms. Caraballo spoke on behalf of a former employee and urged for reconsideration of the decision. She described him as someone who inspired and encouraged the students.

At 8:16 p.m., a resolution was made by Erin Walsh, and seconded by Ed Casswell, to extend the public comment portion of the meeting for an additional (30) minutes.

All in favor – Motion carried 4-0

- Mister G. LaMacchia spoke on behalf of a former employee and urged for reconsideration of the decision. He described him as a pillar in the community who provides support to students.

There were no further questions/comments.

## **XXIX ADJOURNMENT**

At 8:18 p.m. Michael Lisa made a motion, and Erin Walsh seconded, to adjourn the meeting.

All in favor – Motion carried 4-0

Respectfully submitted,

Kelly White  
District Clerk

**MINUTES**  
**ROCKY POINT PUBLIC SCHOOLS**  
**BOARD OF EDUCATION**  
**EXECUTIVE SESSION**  
**March 7, 2024**

Ms. Ward called the meeting to order at 4p.m. in the conference room at Rocky Point High School.

Present: Jessica Ward, President  
Michael Lisa, Vice President  
Susan Sullivan, Trustee (Via phone, leaving at 5:48 p.m.)  
Erin Walsh, Trustee  
Kelly White, District Clerk

Also Present: Scott O'Brien, Ed.D., Superintendent of Schools  
Susann Crossan, Assistant Superintendent  
Christopher Van Cott, Assistant Superintendent for Business  
Kevin Seaman, Esq.  
Jonathon Rufa, Director of Physical Education, Athletics, Health and Intramurals  
James Moeller, Principal, RPHS  
Dawn Meyers, Principal, RPMS

Absent: Edward Casswell, Trustee  
Aaron Factor Ed.D., Assistant Superintendent for Curriculum and Instruction

**EXECUTIVE SESSION**

At 4:00 p.m. a motion was made by Michael Lisa, and seconded by Erin Walsh, to adjourn to Executive Session to discuss confidential personnel matters.

All in favor – Motion carried 4-0

**ADJOURNMENT**

At 6:20 p.m. a motion was made by Erin Walsh, and seconded by Michael Lisa, to adjourn the meeting.

All in favor – Motion carried 3-0

Respectfully submitted,

Kelly White  
District Clerk

**Budget Transfer Summary Report**  
**February 2024**

<b>From Account</b>		<b>To Account</b>				
<b>From Account #</b>	<b>Description</b>	<b>Amount</b>	<b>To Account #</b>	<b>Description</b>	<b>Amount</b>	<b>Reason</b>
A2138441033040	Dues Membership	\$ 75.00	A2138500033040	Supplies	\$ 75.00	PO#100687 Should be from Dues/Memberahip
A1621408040000	Emerg. & Unforseen Repairs	\$ 26,046.00	A1621400040000	Contractual	\$ 28,998.00	Replace. LP Camera, DW Flood & Boiler Monitoring
A1621461040000	Service Contracts	\$ 2,952.00				Emergency Repairs to Condensate Return Pipes & Steam Traps
A1621462040000	Services	\$ 3,916.00	A1620521040000	Custodial Supplies	\$ 13,202.00	Oil Burner Heating Repairs, Custodial Supplies,
A1621461040000	Service Contracts	\$ 922.00	A1621520040000	Bldg. & Grounds Materials	\$ 1,564.00	Roof Repair, Cesspool Service, Abatement
A1620419040000	Fuel Oil	\$ 32,792.00	A1621400040000	Contractual	\$ 22,864.00	Services
A2110130030000	Teachers Salaries 7-12	\$ 60,000.00	A2815400040000	Contractual	\$ 60,000.00	Replenish Substitute Nurse Code
A2855433040000	Official Fees	\$ 99.98	A2855560040000	Uniforms	\$ 99.98	MS Boys Tennis Uniforms
A2855441040000	Dues & Memberships	\$ 250.00	A2855436040000	Student Fees	\$ 250.00	Cheer Meeting Speaker 1.29.24
A2110130030000	Teachers' Salaries 7-12	\$ 26,099.00	A1621400040000	Contractual	\$ 26,099.00	Auditorium Seating, JAE Library Closets, Insurance
A2110130030000	Teachers' Salaries 7-12	\$ 59,099.00	A1620521040000	Custodial Supplies	\$ 59,099.00	Claim Deductible, Teacher's Desks, Custodial Supplies
A2280436033185	Student Entry Fees	\$ 66.00	A2280406033185	Transportation	\$ 66.00	Cosmo Trip to Suffolk Community College, Brentwood
A2110400033121	Contractual-HS Musical Production	\$ 3,732.00	A2110400030000	Contractual	\$ 3,732.00	Theatrical Rights Worldwide Materials
A2110130030000	Teachers Salaries 7-12	\$ 85,477.00	A2630515750000	Computer Supplies	\$ 85,477.00	Reclass Equipment Code Expense to Supply Code
A2110130030000	Teachers Salaries 7-12	\$ 11,908.00	A1621400040000	Contractual	\$ 11,908.00	Replacement Compressor for HS Auditorium
A2110130030000	Teachers Salaries 7-12	\$ 10,206.00	A1620400040000	Contractual	\$ 10,206.00	& Buildings & Grounds Supplies



John F. Dennehy, Jr.  
Certified Public Accountant, P.C.

February 28, 2024

Board of Education  
Rocky Point School District  
90 Rocky Point-Yaphank Road  
Rocky Point, NY 11778

*Re: Internal Claims Audit Report for the period  
February 1, 2024 through February 29, 2024*

Board of Education:

I have completed my internal claims auditing services for the Rocky Point School District covering the period February 1, 2024 through February 29, 2024. The services I performed, as outlined within my proposal, include reviewing all claims against the District. The purpose of this report is to update the Board of Education on work performed to date, my findings, and recommendations.

For ease of reference I have categorized the remainder of this report as follow:

#### Internal Claims Audit Services

#### Exhibits

#### INTERNAL CLAIMS AUDIT SERVICES

The internal claims audit services performed on each claim against the District consisted of:

1. Verification of the accuracy of invoices and claim forms
2. Ensuring proper approval of all purchases; checking that purchases constitute legal expenses of the school district
3. Determining that purchase orders have been issued in accordance with Board of Education policy, and applicable state laws

Board of Education  
Rocky Point School District  
February 28, 2024

Page 2

*Re: Internal Claims Audit Report for the time period of  
February 1, 2024 through February 29, 2024*

4. Comparison of invoices or claims with previously approved contracts
5. Reviewing price extensions, claiming of applicable discounts, inclusion of shipping and freight charges
6. Approving all charges that are presented for payment which are supported with documentary evidence indicating compliance with all pertinent laws, policies and regulations

Over the time period of February 1, 2024 through February 29, 2024 I have audited 246 claims against the District in the amount of \$5,846,215.40. (See attached Exhibit I) I made inquiries and/ or observations into 48 claims in the amount of \$277,576.06. I have summarized the inquiries and/or observations as well as the resolutions within Exhibit II. It should be noted that currently, there are 0 outstanding inquiries in regards to the audit of the claims made against the District for the period of February 1, 2024 through February 29, 2024. I have summarized all voided checks and notable exceptions in Exhibit III.

\*\*\*\*\*

I trust that the foregoing comments are clear. If you have any questions or you would like to discuss this matter further, please contact me at 631-928-5406.

Very truly yours,

John F. Dennehy, Jr.  
Certified Public Accountant

**Rocky Point School District**  
**Internal Claims Audit By Fund**  
**Exhibit I**

Warrant Date	Audit Date	Warrant #	Fund	# of Checks	\$ Value of Checks	# of Inquiries	\$ Value of Inquiries	# of Resolved Inquiries	# of Outstanding Inquiries	Check Sequence
2/7/2024	2/7/2024	82	A	45	\$819,812.48	13	\$33,770.80	13	-	122012-122056
2/7/2024	2/7/2024	83	A	1	\$6,865.00	-	\$0.00	-	-	13703
2/9/2024	2/7/2024	85	A	25	\$724,387.81	-	\$0.00	-	-	13704-13710, 5117238-5117255
2/14/2024	2/14/2024	86	A	45	\$1,422,102.90	15	\$89,902.36	15	-	122057-122099
2/23/2024	2/16/2024	88	A	26	\$690,587.28	-	\$0.00	-	-	13711-13718, 5117256-5117273
2/28/2024	2/28/2024	89	A	59	\$1,782,682.06	16	\$61,744.19	16	-	122100-122157
2/28/2024	2/28/2024	90	A	1	\$6,865.00	-	\$0.00	-	-	13719
2/14/2024	2/14/2024	24	C	17	\$107,386.86	2	\$87,448.71	2	-	13327-13343
2/28/2024	2/28/2024	25	C	13	\$26,699.64	2	\$4,710.00	2	-	13344-13356
2/28/2024	2/28/2024	14	CM3	1	\$2,062.00	-	\$0.00	-	-	11518
2/7/2024	2/7/2024	19	F	5	\$92,353.55	-	\$0.00	-	-	4933-4937
2/14/2024	2/14/2024	20	F	1	\$6,750.00	-	\$0.00	-	-	4938
2/28/2024	2/28/2024	21	F	6	\$95,802.56	-	\$0.00	-	-	4939-4944
2/7/2024	2/7/2024	17	H	1	\$61,858.26	-	\$0.00	-	-	1202
<b>TOTAL</b>				<b>246</b>	<b>\$ 5,846,215.40</b>	<b>48</b>	<b>\$ 277,576.06</b>	<b>48</b>	<b>-</b>	

Legend:	
A - General	P (A) - Chase General
C - Cafeteria	T - Trust & Agency
F - Federal	HB - Bond 2003
H - Capital	CM- Misc Spec Revenue
HCP - Capital Projects	TE-Expendable Trust

**John F. Dennehy, Jr.**  
**Certified Public Accountant, PC**

**Rocky Point School District**  
**Claims Audit - Analysis by Number of Inquiries & Dollar Value**  
**Summary of Inquiries / Resolutions and Percentage of Total Claims & Dollar Value of Claims**  
**Exhibit II**

**2023 / 2024 YTD**

**Analysis by Number of Inquiries**

Reason For Inquiry	Resolution	Jan-24	Feb-24	Mar-24	Apr-24	May-24	Jun-24
All invoices not reflected on check	Pay unpaid invoice(s) next warrant	0.00%	0.00%	#DIV/0!	#DIV/0!	#DIV/0!	#DIV/0!
Check amount not equal to invoices	Difference <\$5; Immaterial, claim paid	1 0.50%	0.00%	#DIV/0!	#DIV/0!	#DIV/0!	#DIV/0!
Check amount not equal to invoices	Overpaid recurring vendor by less than \$100; credit will be taken off on next payment to vendor	0.00%	0.00%	#DIV/0!	#DIV/0!	#DIV/0!	#DIV/0!
Check amount not equal to invoices	Void & reissue	1 0.50%	0.00%	#DIV/0!	#DIV/0!	#DIV/0!	#DIV/0!
Check issued prior to service	Void & reissue at time of service	0.00%	0.00%	#DIV/0!	#DIV/0!	#DIV/0!	#DIV/0!
Credit not taken	Recurring vendor; credit memo pulled from pocket to apply to next invoice	0.00%	0.00%	#DIV/0!	#DIV/0!	#DIV/0!	#DIV/0!
Current year expense paid prior year P.O.	F.O. Funds carried over	2 0.50%	0.00%	#DIV/0!	#DIV/0!	#DIV/0!	#DIV/0!
Duplicate payment	Check void by AP	0.00%	0.00%	#DIV/0!	#DIV/0!	#DIV/0!	#DIV/0!
Incorrect vendor name	Void & reissue	0.00%	0.00%	#DIV/0!	#DIV/0!	#DIV/0!	#DIV/0!
Insufficient supporting backup	Hold for missing information	0.00%	0.00%	#DIV/0!	#DIV/0!	#DIV/0!	#DIV/0!
Insufficient supporting backup	Backup Provided	1 0.50%	0.00%	#DIV/0!	#DIV/0!	#DIV/0!	#DIV/0!
Insufficient supporting backup	Void check	0.00%	0.00%	#DIV/0!	#DIV/0!	#DIV/0!	#DIV/0!
Invoice date precedes PO date	Noted by Business Office	17 4.50%	19 7.20%	#DIV/0!	#DIV/0!	#DIV/0!	#DIV/0!
Invoice over 90 days outstanding/undated	Verified no duplicate payment	24 6.50%	15 5.80%	#DIV/0!	#DIV/0!	#DIV/0!	#DIV/0!
Invoices not listed separately on check	Void and reissue with all invoices itemized separately	0.00%	0.00%	#DIV/0!	#DIV/0!	#DIV/0!	#DIV/0!
Invoice previously stamped by claims auditor	Confirmed original check void	2 0.50%	3 1.20%	#DIV/0!	#DIV/0!	#DIV/0!	#DIV/0!
Missing administrator approval endorsement	Received proper authorization	0.00%	0.00%	#DIV/0!	#DIV/0!	#DIV/0!	#DIV/0!
Missing receiving signature on invoice or PO	Verified receipt of goods/services	0.00%	0.00%	#DIV/0!	#DIV/0!	#DIV/0!	#DIV/0!
No Purchase Order encumbered	Void & reissue after P.O. encumbered	0.00%	0.00%	#DIV/0!	#DIV/0!	#DIV/0!	#DIV/0!
Not an original invoice	Copy, fax or statement accepted	9 2.50%	4 1.50%	#DIV/0!	#DIV/0!	#DIV/0!	#DIV/0!
Paid sales tax	Void and reissue	0.00%	0.00%	#DIV/0!	#DIV/0!	#DIV/0!	#DIV/0!
PO insufficient funds	PO funds increased post invoice/paid direct from budget code	8 2.20%	8 3.20%	#DIV/0!	#DIV/0!	#DIV/0!	#DIV/0!
Prior year invoice paid current year funds	Noted by Business Office	2 0.50%	1 0.40%	#DIV/0!	#DIV/0!	#DIV/0!	#DIV/0!
Pre-dated Invoice	Hold until service date	0.00%	0.00%	#DIV/0!	#DIV/0!	#DIV/0!	#DIV/0!
Separation of Duties	Same individual signed P.O. and authorized payment; additional admin approval provided	0.00%	0.00%	#DIV/0!	#DIV/0!	#DIV/0!	#DIV/0!
Prepaid Invoice - Improper Procedure	Vendor requires prepayment; advised in future to select a different vendor	0.00%	0.00%	#DIV/0!	#DIV/0!	#DIV/0!	#DIV/0!
<b>Total Number (#) of Inquiries</b>		<b>67 17.70%</b>	<b>48 15.51%</b>	<b>0 #DIV/0!</b>	<b>0 #DIV/0!</b>	<b>0 #DIV/0!</b>	<b>0 #DIV/0!</b>
<b>Total Claims Audited</b>		<b>378 100.00%</b>	<b>246 100.00%</b>	<b>#DIV/0!</b>	<b>#DIV/0!</b>	<b>#DIV/0!</b>	<b>#DIV/0!</b>
<b>Total Outstanding Inquiries</b>		<b>0 0.00%</b>	<b>0 0.00%</b>	<b>0 #DIV/0!</b>	<b>0 #DIV/0!</b>	<b>0 #DIV/0!</b>	<b>2 #DIV/0!</b>

**Rocky Point School District**  
**Claims Audit - Analysis by Number of Inquiries & Dollar Value**  
**Summary of Inquiries / Resolutions and Percentage of Total Claims & Dollar Value of Claims**  
**Exhibit II**

**2023 / 2024 YTD**

**Analysis by Dollar Value**

Reason For Inquiry	Resolution	Jan-24	Feb-24	Mar-24	Apr-24	May-24	Jun-24
All invoices not reflected on check	Pay unpaid invoice(s) next warrant	0.00%	0.00%	#DIV/0!	#DIV/0!	#DIV/0!	#DIV/0!
Check amount not equal to invoices	Difference < \$5; Immaterial, claim paid	141.03 0.00%	0.00%	#DIV/0!	#DIV/0!	#DIV/0!	#DIV/0!
Check amount not equal to invoices	Overpaid recurring vendor by less than \$100; credit will be taken off on next payment to vendor	0.00%	0.00%	#DIV/0!	#DIV/0!	#DIV/0!	#DIV/0!
Check amount not equal to invoices	Void & reissue	19,002.57 0.50%	0.00%	#DIV/0!	#DIV/0!	#DIV/0!	#DIV/0!
Check issued prior to service	Void & reissue at time of service	0.00%	0.00%	#DIV/0!	#DIV/0!	#DIV/0!	#DIV/0!
Credit not taken	Recurring vendor; credit memo pulled from packet to apply to next invoice	0.00%	0.00%	#DIV/0!	#DIV/0!	#DIV/0!	#DIV/0!
Current year expense paid prior year P.O.	P.O. Funds carried over	46,223.58 0.86%	0.00%	#DIV/0!	#DIV/0!	#DIV/0!	#DIV/0!
Duplicate payment	Check void by AP	0.00%	0.00%	#DIV/0!	#DIV/0!	#DIV/0!	#DIV/0!
Incorrect vendor name	Void & reissue	0.00%	0.00%	#DIV/0!	#DIV/0!	#DIV/0!	#DIV/0!
Insufficient supporting backup	Hold for missing information	0.00%	0.00%	#DIV/0!	#DIV/0!	#DIV/0!	#DIV/0!
Insufficient supporting backup	Backup Provided	585.00 0.01%	0.00%	#DIV/0!	#DIV/0!	#DIV/0!	#DIV/0!
Insufficient supporting backup	Void check	0.00%	0.00%	#DIV/0!	#DIV/0!	#DIV/0!	#DIV/0!
Invoice date precedes PO date	Noted by Business Office	99,916.60 1.83%	83,444.93 1.43%	#DIV/0!	#DIV/0!	#DIV/0!	#DIV/0!
Invoice over 90 days outstanding/undated	Verified no duplicate payment	44,882.76 0.81%	114,769.25 1.98%	#DIV/0!	#DIV/0!	#DIV/0!	#DIV/0!
Invoices not listed separately on check	Void and reissue with all invoices itemized separately	0.00%	0.00%	#DIV/0!	#DIV/0!	#DIV/0!	#DIV/0!
Invoice previously stamped by claims auditor	Confirmed original check void	2,595.40 0.05%	2,769.22 0.05%	#DIV/0!	#DIV/0!	#DIV/0!	#DIV/0!
Missing administrator approval endorsement	Received proper authorization	0.00%	0.00%	#DIV/0!	#DIV/0!	#DIV/0!	#DIV/0!
Missing receiving signature on invoice or PO	Verified receipt of goods/services	0.00%	0.00%	#DIV/0!	#DIV/0!	#DIV/0!	#DIV/0!
No Purchase Order encumbered	Void & reissue after P.O. encumbered	0.00%	0.00%	#DIV/0!	#DIV/0!	#DIV/0!	#DIV/0!
Not an original invoice	Copy, fax or statement accepted	51,513.75 0.94%	19,563.69 0.33%	#DIV/0!	#DIV/0!	#DIV/0!	#DIV/0!
Paid sales tax	Void and reissue	0.00%	0.00%	#DIV/0!	#DIV/0!	#DIV/0!	#DIV/0!
PO insufficient funds	PO funds increased post invoice/paid direct from budget code	51,604.32 0.94%	55,821.77 0.95%	#DIV/0!	#DIV/0!	#DIV/0!	#DIV/0!
Prior year invoice paid current year funds	Noted by Business Office	774.82 0.01%	214.00 0.00%	#DIV/0!	#DIV/0!	#DIV/0!	#DIV/0!
Pre-dated Invoice	Hold until service date	0.00%	0.00%	#DIV/0!	#DIV/0!	#DIV/0!	#DIV/0!
Separation of Duties	Same individual signed P.O. and authorized payment; additional admin approval provided	0.00%	0.00%	#DIV/0!	#DIV/0!	#DIV/0!	#DIV/0!
Prepaid Invoice - Improper Procedure	Vendor requires prepayment; advised in future to select a different vendor	0.00%	0.00%	#DIV/0!	#DIV/0!	#DIV/0!	#DIV/0!
<b>Total Value (\$) of Inquiries</b>		<b>216,745.28 5.29%</b>	<b>277,576.05 4.73%</b>	- #DIV/0!	- #DIV/0!	- #DIV/0!	- #DIV/0!
<b>Total Claims Audited</b>		<b>5,470,694.14 100.00%</b>	<b>5,846,215.40 100.00%</b>	#DIV/0!	#DIV/0!	#DIV/0!	#DIV/0!
<b>Total Outstanding Inquiries</b>		- 0.00%	- 0.00%	- #DIV/0!	- #DIV/0!	- #DIV/0!	4,054.66 #DIV/0!



**Rocky Point School District  
Internal Claim Audit  
Notable Exceptions  
Exhibit III**

**Void Checks - February 2024**

<b>Fund</b>	<b>Ck #</b>	<b>Amount \$</b>	<b>Vendor</b>	<b>Warrant #</b>	<b>Warrant Date</b>	<b>Reason For Inquiry</b>	<b>Resolution</b>
None		-					
<b>Total</b>	<b>0 Voids</b>	-					

**Other Notable Exceptions - February 2024**

<b>Fund</b>	<b>Ck #</b>	<b>Amount \$</b>	<b>Vendor</b>	<b>Warrant #</b>	<b>Warrant Date</b>	<b>Reason For Inquiry</b>	<b>Resolution</b>
None		-					
<b>Total</b>	<b>0 Inquiries</b>	-					

**John F. Dennehy, Jr.  
Certified Public Accountant, PC**

**Rocky Point School District  
Internal Claims Audit  
Payroll Audit  
Exhibit IV**

**Audited Payroll Checks - February 2024**

<b>Fund</b>	<b>Ck #</b>	<b>Amount \$</b>	<b>Employee</b>	<b>Payroll Date</b>	<b>Exceptions</b>
PR	338487	1,213.34	Kumar, Michael A.	2/9/2024	None
PR	339039	1,596.73	Conlon, Michael	2/9/2024	None
PR	338647	893.67	Gross, Cara K.	2/9/2024	None
PR	338754	3,485.96	Nentwich, Christopher J.	2/9/2024	None
PR	338599	1,791.29	May, Melissa S.	2/9/2024	None
		<b>\$8,980.99</b>			

\*Please note all checks have been selected at random using a random number generator.

\*\*A result of no exceptions means that the the payroll check is accurate when compared against employee contracts and renewal letters.

**John F. Dennehy, Jr.  
Certified Public Accountant, PC**

# *Interoffice Memorandum*

**TO:** *Dr. Scott O'Brien, Ed.D*

**FROM:** *Kristen White, Executive Director of Pupil Personnel*

**DATE:** *March 18, 2024*

**RE:** *Board Action Sheets*

---

*Below please find the schedule to be approved at the March 18, 2024 Board of Education meeting:*

<b>SCHEDULE- A 3/18/24</b>		
<b>Year</b>	<b>Date</b>	<b>Location</b>
2023-2024	February 12, 2024- March 1, 2024	CSE & SCSE meetings conducted for students attending in-district and out of district placements
2023-2024	February 12, 2024- March 1, 2024	CSE & SCSE Amendments Without Meetings

**BOE ACTION Summary DATE? DECISION?**

CMA BOE Date	CR Doc Committee Responsible	CMA Reason	Decision/Status	CMA Date	CR Expected Grade	CR Next Recommended School (> 2010-11 SY)	Program Start	Program End	Program Ratio	Program Frequency	Program Period	Program Duration	Program Location	Related Service	RS Start	RS End	RS Ratio	RS Frequency	RS Period	RS Duration
03/18/2024	CSE	Program Review	Classified	01/16/2024	05		Integrated 09/06/2023	06/21/2024		5 Weekly		40	Classroom	Speech/Language Therapy	09/13/2023	06/12/2024	Small Group	2 Weekly		30
		Program Review	Classified		05		Integrated 09/06/2023	06/21/2024		5 Weekly		40	Classroom	Counseling	01/19/2024	06/12/2024	Individual	1 Weekly		30
		Program Review	Classified		05		Integrated 09/06/2023	06/21/2024		5 Weekly		40	Classroom	Speech/Language Therapy	09/13/2023	06/12/2024	Small Group	2 Weekly		30
		Program Review	Classified		05		Integrated 09/06/2023	06/21/2024		5 Weekly		40	Classroom	Counseling	01/19/2024	06/12/2024	Individual	1 Weekly		30
		Program Review	Classified		05		Integrated 09/06/2023	06/21/2024		5 Weekly		40	Classroom	Speech/Language Therapy	09/13/2023	06/12/2024	Small Group	2 Weekly		30
		Program Review	Classified		05		Integrated 09/06/2023	06/21/2024		5 Weekly		40	Classroom	Counseling	01/19/2024	06/12/2024	Individual	1 Weekly		30
		Program Review	Classified		05		Integrated 09/06/2023	06/21/2024		5 Weekly		80	Classroom	Speech/Language Therapy	09/13/2023	06/12/2024	Small Group	2 Weekly		30
		Program Review	Classified		05		Integrated 09/06/2023	06/21/2024		5 Weekly		80	Classroom	Counseling	01/19/2024	06/12/2024	Individual	1 Weekly		30
		Program Review	Classified	01/17/2024	05		Special Class	09/06/2023	06/21/2024	15:1+1	4 Daily	40	Classroom	Speech/Language Therapy	09/13/2023	06/12/2024	Small Group	2 Weekly		30
		Program Review	Classified		05		Integrated 09/06/2023	06/21/2024		2 Daily		40	Math Class	Speech/Language Therapy	09/13/2023	06/12/2024	Small Group	2 Weekly		30
		Program Review	Classified	01/23/2024	05		Integrated 09/06/2023	06/21/2024		5 Weekly		80	Classroom	Speech/Language Therapy	09/13/2023	06/12/2024	Small Group	2 Weekly		30
		Program Review	Classified		05		Integrated 09/06/2023	06/21/2024		5 Weekly		80	Classroom	Counseling	09/13/2023	06/12/2024	Individual	2 Monthly		30
		Program Review	Classified		05		Integrated 09/06/2023	06/21/2024		5 Weekly		40	Classroom	Speech/Language Therapy	09/13/2023	06/12/2024	Small Group	2 Weekly		30
		Program Review	Classified		05		Integrated 09/06/2023	06/21/2024		5 Weekly		40	Classroom	Counseling	09/13/2023	06/12/2024	Individual	2 Monthly		30
		Program Review	Classified		05		Integrated 09/06/2023	06/21/2024		5 Weekly		40	Classroom	Speech/Language Therapy	09/13/2023	06/12/2024	Small Group	2 Weekly		30
		Program Review	Classified		05		Integrated 09/06/2023	06/21/2024		5 Weekly		40	Classroom	Counseling	09/13/2023	06/12/2024	Individual	2 Monthly		30
		Program Review	Classified	01/24/2024	05		Special Class	01/24/2024	06/21/2024	15:1+1	6 Daily	40	Separate	Speech/Language Therapy	09/13/2023	06/12/2024	Small Group	2 Weekly		30
		Reevaluation Review	Classified	02/02/2024	06		Special Class - Math	09/06/2023	06/21/2024	15:1	5 Weekly	40	Math Class	Speech/Language Therapy	09/13/2023	06/12/2024	Small Group	2 Weekly		30

Reevaluation Review	Classified	06	Integrated Co-teaching Services	09/06/2023 06/21/2024	2x Bi-weekly	40 Humanities Class	Speech/Language Therapy	09/13/2023 06/12/2024	Small Group	2 Weekly	30
Reevaluation Review	Classified	06	Integrated Co-teaching Services	09/06/2023 06/21/2024	5 Weekly	40 Science Class	Speech/Language Therapy	09/13/2023 06/12/2024	Small Group	2 Weekly	30
Program Review	Classified	02/09/2024 08	Integrated Co-teaching Services	09/06/2023 06/21/2024	5 Weekly	40 Math Class					
Program Review	Classified	08	Integrated Co-teaching Services	09/06/2023 06/21/2024	5 Weekly	40 English Class					
Annual Review	Classified	08	Special Class - Social Studies	09/06/2023 06/21/2024 15:1	5 Weekly	40 Social Studies Class					
Annual Review	Classified	08	Special Class - English	09/06/2023 06/21/2024 15:1+1	5 Weekly	40 English Class					
Annual Review	Classified	08	Special Class - Reading	09/06/2023 06/21/2024 15:1+1	5 Weekly	40 Reading Class					
Annual Review	Classified	08	Special Class - Math	09/06/2023 06/21/2024 15:1+1	5 Weekly	40 Math Class					
Annual Review	Classified	08	Special Class - Science	09/06/2023 06/21/2024 15:1+1	5 Weekly	40 Science Class					
Program Review	Classified	Kdg.	Special Class	09/06/2023 06/26/2024 8:1+1	5 Weekly	330 Classroom	Speech/Language Therapy	09/06/2023 06/26/2024	Individual	3 Weekly	30
Program Review	Classified	Kdg.	Special Class	09/06/2023 06/26/2024 8:1+1	5 Weekly	330 Classroom	Parent Counseling and Training	09/06/2023 06/26/2024	Individual	1 Monthly	60
Program Review	Classified	Kdg.	Special Class	09/06/2023 06/26/2024 8:1+1	5 Weekly	330 Classroom	Speech/Language Therapy	09/06/2023 06/26/2024	Small Group	1 Weekly	30
Program Review	Classified	Kdg.	Special Class	09/06/2023 06/26/2024 8:1+1	5 Weekly	330 Classroom	Occupational Therapy	12/12/2023 06/26/2024	Individual	2 Weekly	30
Program Review	Classified	Kdg.	Special Class	09/06/2023 06/26/2024 8:1+1	5 Weekly	330 Classroom	Applied Behavioral Analysis Services	02/14/2024 06/26/2024	Individual	3 Weekly	60
Amendment - Agreement No Meeting	Classified	02/13/2024 07	Special Class	09/06/2023 06/26/2024 8:1:1	5 Weekly	330 Across All Educational Settings	Speech/Language Therapy	09/06/2023 06/26/2024	Individual	2 Weekly	30
Amendment - Agreement No Meeting	Classified	07	Special Class	09/06/2023 06/26/2024 8:1:1	5 Weekly	330 Across All Educational Settings	Parent Counseling and Training	09/06/2023 06/26/2024	Individual	1 Weekly	60
Amendment - Agreement No Meeting	Classified	07	Special Class	09/06/2023 06/26/2024 8:1:1	5 Weekly	330 Across All Educational Settings	Speech/Language Therapy	09/06/2023 06/26/2024	Small Group	1 Weekly	30
Transfer Student - Agreement No Meeting	Classified	02/15/2024 11	Resource Room Program	02/28/2024 06/21/2024 5:1	5 Weekly	40 Resource Room					
Manifestation Determination	Classified	09	Integrated Co-teaching Services	09/06/2023 06/13/2024	5 Weekly	40 English Class	Counseling	09/13/2023 06/12/2024	Individual	1 Weekly	30
Manifestation Determination	Classified	09	Special Class - Math	09/06/2023 06/13/2024 15:1	5 Weekly	40 Math Class	Counseling	09/13/2023 06/12/2024	Individual	1 Weekly	30
Manifestation Determination	Classified	09	Integrated Co-teaching Services	09/06/2023 06/13/2024	5 Weekly	40 Science Class	Counseling	09/13/2023 06/12/2024	Individual	1 Weekly	30
Manifestation Determination	Classified	09	Integrated Co-teaching Services	09/06/2023 06/13/2024	5 Weekly	40 Social Studies Class	Counseling	09/13/2023 06/12/2024	Individual	1 Weekly	30
Manifestation Determination	Classified	09	Integrated Co-teaching Services	09/06/2023 06/13/2024	5 Every 2 weeks	40 Science Class	Counseling	09/13/2023 06/12/2024	Individual	1 Weekly	30
Manifestation Determination	Classified	10	Special Class - English	09/06/2023 06/13/2024 15:1	5 Weekly	40 English Class	Counseling	01/30/2024 06/12/2024	Individual	1 Weekly	30
Manifestation Determination	Classified	10	Special Class - Math	09/06/2023 06/13/2024 15:1	5 Weekly	40 Math Class	Counseling	01/30/2024 06/12/2024	Individual	1 Weekly	30
Manifestation	Classified	10	Special	09/06/2023 06/13/2024 15:1	5 Weekly	40 Social	Counseling	01/30/2024 06/12/2024	Individual	1 Weekly	30

Determination			Class - Social Studies			Studies Class				
Manifestation Determination	Classified	10	Special Class - Science	01/30/2024 06/13/2024 15:1	5 Weekly	40 Science Class	Counseling	01/30/2024 06/12/2024 Individual	1 Weekly	30
Manifestation Determination	Classified	10	Special Class - Science	01/30/2024 06/13/2024 15:1	5 Every 2 weeks	40 Science Class	Counseling	01/30/2024 06/12/2024 Individual	1 Weekly	30
Initial Eligibility Determination Meeting	Classified	02/26/2024 01	Resource Room Program	02/26/2024 06/21/2024 5:1	5 Weekly	40 Resource Room				
Reevaluation/Annual Review	Declassified Support Services	02/14/2024 08	Integrated	09/06/2023 06/21/2024	5 Weekly	40 English Class				
Initial Eligibility Determination Meeting	Ineligible	02/26/2024 01								
Initial Eligibility Determination Meeting	Ineligible	02/28/2024 08								

**CR Doc Committee Responsible Sub Total: 52**

---

**Total Records: 52**  
**Total Students: 16**

# *Interoffice Memorandum*

**TO:** *Dr. Scott T. O'Brien, Superintendent*

**FROM:** *Kristen White, Executive Director of Pupil Personnel Services*

**DATE:** *3/18/2024*

**RE:** *Board Action Sheets*

---

*Below please find the schedule to be approved at the 3/18/2024 Board of Education meeting:*

<b>SCHEDULE- B 3/18/2024</b>	
<b>Date</b>	<b>Location</b>
<i>2/1/2024</i>	<i>CPSE Committee</i>
<i>2/8/2024</i>	<i>CPSE Committee</i>
<i>2/8/2024</i>	<i>CPSE Amendment</i>
<i>2/14/2024</i>	<i>CPSE Committee</i>
<i>2/15/2024</i>	<i>CPSE Committee</i>
<i>2/16/2024</i>	<i>CPSE Committee</i>
<i>2/26/2024</i>	<i>CPSE Amendment</i>

*Dr. Scott T. O'Brien-Board Action Sheets/kao*

**BOE ACTION Summary DATE? DECISION?**

CMA BOE Date	CR Doc Committee Responsible	CMA Reason	Decision/Status	CMA Date	CR Expected Grads	CR Next Recommended School (>2010-11 SY)	Program	Program Start	Program End	Program Ratio	Program Frequency	Program Period	Program Duration	Program Location	Related Service	RS Start	RS End	RS Ratio	RS Frequency	RS Period	RS Duration
03/18/2024	CPSE	Amendment	Classified Preschool	02/08/2024	Preschool										Speech/Language Therapy	02/08/2024	06/21/2024	Individual	3 Weekly		30
		Initial Eligibility Determination Meeting	Classified Preschool	02/14/2024	Preschool										Speech/Language Therapy	03/04/2024	06/21/2024	Individual	2 Weekly		30
		Initial Eligibility Determination Meeting	Classified Preschool		Preschool										Occupational Therapy	03/04/2024	06/21/2024	Individual	2 Weekly		30
		Initial Eligibility Determination Meeting	Classified Preschool		Preschool										Speech/Language Therapy	03/04/2024	06/21/2024	Individual	2 Weekly		30
		Initial Eligibility Determination Meeting	Classified Preschool		Preschool										Occupational Therapy	03/04/2024	06/21/2024	Individual	2 Weekly		30
		Transfer Student - Agreement No Meeting	Classified Preschool	02/15/2024	Preschool		Special Class in an Integrated Setting	02/15/2024	06/26/2024	12:1+2		5 Weekly		300 Classroom	Speech/Language Therapy	02/15/2024	06/26/2024	Small Group	2 Weekly		30
		Transfer Student - Agreement No Meeting	Classified Preschool		Preschool		Special Class in an Integrated Setting	02/15/2024	06/26/2024	12:1+2		5 Weekly		300 Classroom	Occupational Therapy	02/15/2024	06/26/2024	Individual	2 Weekly		30
		Transfer Student - Agreement No Meeting	Classified Preschool		Preschool		Special Class in an Integrated Setting	02/15/2024	06/26/2024	12:1+2		5 Weekly		300 Classroom	Parent Counseling and Training	02/15/2024	06/26/2024	Individual	2 Monthly		30
		Transfer Student - Agreement No Meeting	Classified Preschool		Preschool		Special Class in an Integrated Setting	02/15/2024	06/26/2024	12:1+2		5 Weekly		300 Classroom	Physical Therapy	02/15/2024	06/26/2024	Individual	1 Weekly		30
		Program Review	Classified Preschool	02/16/2024	Preschool		Special Class in an Integrated Setting	09/06/2023	06/26/2024	12:1+2		5 Weekly		300 Classroom	Speech/Language Therapy	09/06/2023	06/26/2024	Individual	2 Weekly		30
		Program Review	Classified Preschool		Preschool		Special Class in an Integrated Setting	09/06/2023	06/26/2024	12:1+2		5 Weekly		300 Classroom	Occupational Therapy	09/06/2023	06/26/2024	Individual	2 Weekly		30
		Program Review	Classified Preschool		Preschool		Special Class in an Integrated Setting	09/06/2023	06/26/2024	12:1+2		5 Weekly		300 Classroom	Parent Counseling and Training	09/06/2023	06/26/2024	Individual	1 Monthly		60
		Program Review	Classified Preschool		Preschool		Special Class in an Integrated Setting	09/06/2023	06/26/2024	12:1+2		5 Weekly		300 Classroom	Psychological Counseling Services	03/04/2024	06/26/2024	Individual	1 Weekly		30
		Amendment	Classified Preschool	02/26/2024	Preschool		Special Class in an Integrated Setting	09/06/2023	06/26/2024	12:1+2		5 Weekly		300 Classroom	Speech/Language Therapy	09/06/2023	06/26/2024	Individual	3 Weekly		30
		Amendment	Classified Preschool		Preschool		Special Class in an Integrated Setting	09/06/2023	06/26/2024	12:1+2		5 Weekly		300 Classroom	Occupational Therapy	09/06/2023	06/26/2024	Individual	2 Weekly		30
		Amendment	Classified Preschool		Preschool		Special Class in an Integrated Setting	09/06/2023	06/26/2024	12:1+2		5 Weekly		300 Classroom	Physical Therapy	09/06/2023	06/26/2024	Individual	2 Weekly		30
		Amendment	Classified Preschool		Preschool										Speech/Language Therapy	12/04/2023	06/21/2024	Individual	2 Weekly		30
		Amendment	Classified Preschool		Preschool										Speech/Language Therapy	01/02/2024	06/21/2024	Individual	1 Weekly		30



Initial Eligibility Determination Meeting	Preschool Classified Preschool/No Services Continued EI	02/01/2024	Preschool	Special Class	02/01/2024 06/21/2024 8:1:1	5 Weekly	300 Classroom	Therapy Occupational Therapy	02/01/2024 06/21/2024 Individual	2 Weekly	30
Initial Eligibility Determination Meeting	Classified Preschool/No Services Continued EI		Preschool	Special Class	02/01/2024 06/21/2024 8:1:1	5 Weekly	300 Classroom	Speech/Language Therapy	02/01/2024 06/21/2024 Individual	3 Weekly	30
Initial Eligibility Determination Meeting	Classified Preschool/No Services Continued EI		Preschool	Special Class	02/01/2024 06/21/2024 6:1:3.5	5 Weekly	300 Classroom				
Initial Eligibility Determination Meeting	Classified Preschool/No Services Continued EI	02/08/2024	Preschool	Special Education Itinerant Services	02/08/2024 06/21/2024 1:1	3 Weekly	60 Home/Community	Speech/Language Therapy	02/08/2024 06/21/2024 Individual	3 Weekly	30
Initial Eligibility Determination Meeting	Classified Preschool/No Services Continued EI	02/14/2024	Preschool	Special Class	02/14/2024 06/21/2024 8:1+2	5 Weekly	300 Classroom	Parent Counseling and Training	02/14/2024 06/21/2024 Individual	1 Monthly	60
Initial Eligibility Determination Meeting	Classified Preschool/No Services Continued EI		Preschool	Special Class	02/14/2024 06/21/2024 8:1+2	5 Weekly	300 Classroom	Speech/Language Therapy	02/14/2024 06/21/2024 Individual	3 Weekly	30

CR Doc Committee Responsible Sub Total: 24

Total Records: 24

Total Students: 11

**BOE ACTION Summary DATE? DECISION?**

CMA BOE Date	CR Doc Committee Responsible	CMA Reason	Decision/Status	CMA Date	CR Expected Grade	CR Next Recommended School (>2010-11 SY)	Program	Program Start	Program End	Program Ratio	Program Frequency	Program Period	Program Duration	Program Location	Related Service	RS Start	RS End	RS Ratio	RS Frequency	RS Period	RS Duration	
03/18/2024	CPSE	Initial Eligibility Determination Meeting	Classified Preschool	02/01/2024	Preschool		Special Class	09/04/2024	06/20/2025	6:1:3.5	5 Weekly		300	Classroom								
		Initial Eligibility Determination Meeting	Classified Preschool		Preschool		Special Class	09/04/2024	06/27/2025	8:1:1	5 Weekly		300	Classroom	Speech/Language Therapy	09/04/2024	06/27/2025	Individual	3 Weekly		30	
		Initial Eligibility Determination Meeting	Classified Preschool		Preschool		Special Class	09/04/2024	06/27/2025	8:1:1	5 Weekly		300	Classroom	Occupational Therapy	09/04/2024	06/27/2025	Individual	2 Weekly		30	
		Initial Eligibility Determination Meeting	Classified Preschool	02/08/2024	Preschool		Special Education Itinerant Services	09/04/2024	06/27/2025	1:1	3 Weekly		60	Home/Community	Speech/Language Therapy	09/04/2024	06/27/2025	Individual	3 Weekly		30	
		Initial Eligibility Determination Meeting	Classified Preschool	02/14/2024	Preschool		Special Class	09/04/2024	06/27/2025	12:1+1	5 Weekly		180	Classroom	Speech/Language Therapy	09/04/2024	06/27/2025	Individual	3 Weekly		30	
		Initial Eligibility Determination Meeting	Classified Preschool		Preschool		Special Class	09/04/2024	06/27/2025	12:1+1	5 Weekly		180	Classroom	Parent Counseling and Training	09/04/2024	06/27/2025	Individual	1 Monthly		60	
<b>CR Doc Committee Responsible Sub Total: 6</b>																						

**Total Records: 6**

**Total Students: 4**

HOLD TO LIGHT TO VIEW TRUE WATERMARK IN PAPER HEAT SENSITIVE RED LOCK DISAPPEARS WHEN HEATED

0316

ROCKY POINT PTA

DATE 3/9/2024

1-2/210

PAY TO THE ORDER OF

Rocky Point Schols

\$ 218.00/100

Two-Hundred and Eighteen Dollars and

200 Cents

DOLLARS

**CHASE**  
JPMorgan Chase Bank, N.A.  
www.Chase.com

FOR

RPMS Donation

*[Signature]*  
Dated and

85827273011



Details on back Security Features

March 11, 2024

Hi Deb,

I have attached for you a check from the Rocky Point PTA for the amount of \$218.00.

This is for the 6<sup>th</sup> Grade Field Trip to Medieval Times.

Thank you,

Barbara Wells

**ROCKY POINT PUBLIC SCHOOLS**

**SURPLUS EQUIPMENT DISPOSAL**

School: RPHS

Department: HPEAI

Name: Jonathon Rufa

Description	Model#/Serial#	Property Tag #	Quantity	Reason for Disposal
Elliptical Machine	Vision S7200HRT	N/A	1	End of Life

Assistant Superintendent Signature 

Date: 3/8/24

## Community Relations

**SUBJECT: PROHIBITION OF WEAPONS ON SCHOOL GROUNDS**

With the exception of law enforcement officers, as permitted by law, contracted armed security guards possessing a valid New York State Armed School Security Guard certification, and individuals who have the express written permission of the Board of Education or its designee, no person may have in his/her possession any weapon on school grounds, in any District building, on a school bus or District vehicle, or at any school sponsored activity or setting under the control and supervision of the District. This prohibition shall include, but not be limited to: any of the objects or instruments referred to in Section 265.01 of the New York State Penal Law; any air-gun, spring-gun or other instrument or weapon in which the propelling force is a spring, air, piston or CO2 cartridge; and any object that could be considered a reasonable facsimile of a weapon.

Penal Law Sections 265.01-265.06, 265.20

NOTE: Refer also to Policies #3410 -- Code of Conduct on School Property  
#7313 -- Suspensions of Students  
#7360 -- Weapons in School and the Gun-Free Schools Act

Non-Instructional/Business  
Operations**SUBJECT: ACCOUNTING OF FIXED ASSETS**

The School Business Official shall be responsible for accounting for general fixed assets according to the procedures outlined by the Uniform System of Accounts for School Districts and GASB Statement 34 Regulations.

These accounts will serve to:

- a) Maintain a physical inventory of assets;
- b) Establish accountability;
- c) Determine replacement costs; and
- d) Provide appropriate insurance coverage.

Fixed assets with a minimum value established by the Board that have a useful life of one (1) year or more and physical characteristics not appreciably affected by use or consumption shall be inventoried and recorded on an annual basis. Fixed assets shall include land, buildings, equipment and materials.

The Board has established that such threshold is five thousand dollars (\$5,000). A standardized depreciation method and averaging convention shall also be established for depreciation calculations.

Fixed assets acquired having a value equal to or greater than the established threshold are considered depreciable assets and shall be inventoried for the purposes of GASB 34 accounting practices and placed on a depreciation schedule according to its asset class and estimated useful life as stipulated by the New York State Comptroller's Office or the Internal Revenue Service (IRS).

Assets shall be recorded at initial cost or, if not available, at estimated initial cost; gifts of fixed assets shall be recorded at estimated fair value at the time of the gift. A property record will be maintained for each asset and will contain, where possible, the following information:

- a) Date of acquisition;
- b) Description;
- c) Cost or value;
- d) Location;
- e) Asset type;
- f) Estimated useful life;
- g) Replacement cost;
- h) Current value;
- i) Salvage value;
- a) Date and method of disposition; and
- b) Responsible official.

The School Business Official shall arrange for the ~~annual~~ inventory and appraisal of School District property, equipment and material at least once every five fiscal years. Additionally, the Business Office will perform periodic inventory counts annually. Any discrepancies between an inventory and the District's property records on file should be traced and explained.

---

Adoption Date 3/23/09

Revision Date 11/19/12, 3/18/24

Review Date

**Bid Response Log: Rocky Point Union Free School District**

Funding Year: 2024-2025

Form 470 No.: 240008017

Close Date: February 15th, 2024

Vendor Response Information					
Received Date	Vendor	SPIN		Bid Status	Comments/Notes*
02/13/24	Data Network Solutions	143009866		Accepted	Only bid 1Gbps IA for 36 months
02/02/24	Verizon	143001197		Accepted	1 Gbps Dedicated Internet Access, 1 Gbps WAN, and 100 Mbps E-Line for 36 Months
02/05/24	Eastern Suffolk Boces	143006632		Accepted	1 Gbps Dedicated Internet Access, 1 Gbps WAN and 100 Mbps E-Line for 36 Months -
02/13/24	Lightpath	143000072		Accepted	1 Gbps Dedicated Internet Access, Fiber w 1G Optics, 100 M E-Line for 36 months
	Cytranet	143051061		Accepted	1 Gbps Dedicated Internet Access, 1 Gbps WAN and 100 Mbps E-Line. No specified term.

\*Non-responsive bids should note reason(s) for disqualification in the Comments section of the log. They should not be included on any assessment sheet.



## Assessment Worksheet

Entity: Rocky Point Union Free School District  
 Funding Year: 2024-2025  
 Form 470#: 240008017  
 Close Date: February 15th, 2024

Products/Services Assessed: 36 Month Contract for 1 Gbps of Internet Access  
 Evaluator Name and Title: Christopher A. Van Cott, Assistant Superintendent for Business  
 Date Evaluation Completed: Wednesday, February 28, 2024

Lowest E-rate Eligible Cost: \$31,140.00

### Vendor Scoring

Selection Criteria	Weight	Verizon		Eastern Suffolk Boces		Lightpath		DNS		Cytranet	
		Eligible \$	\$31,977.96	Eligible \$	\$33,300.00	Eligible \$	\$31,140.00	Eligible \$	\$39,240.00	Eligible \$	\$55,090.00
		Raw Score	Weighted Score	Raw Score	Weighted Score	Raw Score	Weighted Score	Raw Score	Weighted Score	Raw Score	Weighted Score
Cost of E-rate Eligible Products/Services*	40%	9.74	38.95%	9.35	37.41%	10.00	40.00%	7.94	31.74%	5.65	22.61%
Meets/Understands Needs	30%	10.00	30.00%	10.00	30.00%	10.00	30.00%	5.00	15.00%	5.00	15.00%
Previous Experience with School/Library	30%	7.00	21.00%	10.00	30.00%	8.00	24.00%	1.00	3.00%	1.00	3.00%
<b>Overall Ranking</b>	<b>100%</b>	<b>89.95%</b>		<b>97.41%</b>		<b>94.00%</b>		<b>49.74%</b>		<b>40.61%</b>	

Assessment Notes:	
Verizon	Reputable vendor but not used in past for this service; awarded "7" out of 10 points for "Previous Experience with School/Library"
Eastern Suffolk Boces	Currently utilize this vendor and satisfied with service. BOCES also provide BOCES aid on balance of costs not covered by E-Rate
Lightpath	Have utilized this reputable vendor in past but not since 2016. As such, awarded "8" points out of 10 for "Previous Experience with School/Library"
DNS	No experience with vendor
Cytranet	No experience with vendor; did not specify a term

Scoring Notes:	
* Cost of E-rate eligible products/services is the primary consideration.	
** Raw score for eligible products is based on the formula ((lowest cost/cost being compared)x10).	
*** All other raw scores based on a scale of 0 to 10: 0=lowest/worst possible, 5=neutral, 10=highest/best possible.	

## Assessment Worksheet

Entity: Rocky Point Union Free School District  
 Funding Year: 2024-2025  
 Form 470#: 240008017  
 Close Date: February 15th, 2024

Products/Services Assessed: 36 Month Contract for 1 Gb WAN  
 Evaluator Name and Title: Christopher A. Van Cott, Assistant Superintendent for Business  
 Date Evaluation Completed: Wednesday, February 28, 2024

Lowest E-rate Eligible Cost: \$17,316.00

### Vendor Scoring

Selection Criteria	Weight	Verizon		Eastern Suffolk Boces		Lightpath		Cytranet	
		Eligible \$	\$78,408.00	Eligible \$	\$17,316.00	Eligible \$	\$17,964.00	Eligible \$	\$68,950.00
		Raw Score	Weighted Score	Raw Score	Weighted Score	Raw Score	Weighted Score	Raw Score	Weighted Score
Cost of E-rate Eligible Products/Services*	40%	2.21	8.83%	10.00	40.00%	9.64	38.56%	2.51	10.05%
Meets/Understands Needs	30%	10.00	30.00%	10.00	30.00%	10.00	30.00%	5.00	15.00%
Previous Experience with School/Library	30%	7.00	21.00%	10.00	30.00%	8.00	24.00%	1.00	3.00%
<b>Overall Ranking</b>	<b>100%</b>	<b>59.83%</b>		<b>100.00%</b>		<b>92.56%</b>		<b>28.05%</b>	

Assessment Notes:	
Verizon	Reputable vendor but not used in past for this service; awarded "7" out of 10 points for "Previous Experience with School/Library"
Eastern Suffolk Boces	Currently utilize this vendor and satisfied with service. BOCES also provide BOCES aid on balance of costs not covered by E-Rate
Lightpath	Have utilized this reputable vendor in past but not since 2016. As such, awarded "8" points out of 10 for "Previous Experience with School/Library"
Cytranet	No experience with vendor; did not specify a term

Scoring Notes:	
* Cost of E-rate eligible products/services is the primary consideration.	
** Raw score for eligible products is based on the formula ((lowest cost/cost being compared)x10).	
*** All other raw scores based on a scale of 0 to 10: 0=lowest/worst possible, 5=neutral, 10=highest/best possible.	

## Assessment Worksheet

Entity: Rocky Point Union Free School District  
 Funding Year: 2024-2025  
 Form 470#: 240008017  
 Close Date: February 15th, 2024

Products/Services Assessed: 36 Month Contract for 100 Mbps E-Line  
 Evaluator Name and Title: Christopher A. Van Cott, Assistant Superintendent for Business  
 Date Evaluation Completed: Wednesday, February 28, 2024

Lowest E-rate Eligible Cost: \$7,380.00

### Vendor Scoring

Selection Criteria	Weight	Verizon		Eastern Suffolk Boces		Lightpath		Cytranet					
		Eligible \$	Raw Score	Weighted Score	Eligible \$	Raw Score	Weighted Score	Eligible \$	Raw Score	Weighted Score			
Cost of E-rate Eligible Products/Services*	40%	\$41,184.00	1.79	7.17%	\$7,380.00	10.00	40.00%	\$19,080.00	3.87	15.47%	\$26,074.00	2.83	11.32%
Meets/Understands Needs	30%		10.00	30.00%		10.00	30.00%		10.00	30.00%		5.00	15.00%
Previous Experience with School/Library	30%		7.00	21.00%		10.00	30.00%		8.00	24.00%		1.00	3.00%
<b>Overall Ranking</b>	<b>100%</b>			<b>58.17%</b>			<b>100.00%</b>			<b>69.47%</b>			<b>29.32%</b>

Assessment Notes:	
Verizon	Reputable vendor but not used in past for this service; awarded "7" out of 10 points for "Previous Experience with School/Library"
Eastern Suffolk Boces	Currently utilize this vendor and satisfied with service. BOCES also provide BOCES aid on balance of costs not covered by E-Rate
Lightpath	Have utilized this reputable vendor in past but not since 2016. As such, awarded "8" points out of 10 for "Previous Experience with School/Library"
Cytranet	No experience with vendor; did not specify a term

Scoring Notes:	
* Cost of E-rate eligible products/services is the primary consideration.	
** Raw score for eligible products is based on the formula ((lowest cost/cost being compared)x10).	
*** All other raw scores based on a scale of 0 to 10: 0=lowest/worst possible, 5=neutral, 10=highest/best possible.	

**Rocky Point UFSD**  
**E-Rate Award**  
**Internet Access and WAN**

		<u>Internet</u>		<u>WAN 100 MB E-Line</u>		<u>WAN 1 Gb E-Line</u>	
		<u>Service</u>	<u>Coord Fee</u>	<u>Service</u>	<u>Coord Fee</u>	<u>Service</u>	<u>Coord Fee</u>
Year 1	7/1/2024 - 6/30/2025	11,100.00	1,665.00	2,460.00	419.30	5,772.00	983.82
Year 2	7/1/2025 - 6/30/2026	11,100.00	1,665.00	2,460.00	419.30	5,772.00	983.82
Year 3	7/1/2026 - 6/30/2027	11,100.00	1,665.00	2,460.00	419.30	5,772.00	983.82
<b>Totals</b>		<b>33,300.00</b>	<b>4,995.00</b>	<b>7,380.00</b>	<b>1,257.90</b>	<b>17,316.00</b>	<b>2,951.46</b>
		<u>3-Yr total</u>	<u>Per Year</u>	<u>Est. E-Rate per Year</u>		<u>Est. Net Cost per Year</u>	
Total Service Costs		57,996.00	19,332.00	11,599.20		7,732.80	
Total Coordination Fees		9,204.36	3,068.12	N/A		N/A	

**FY2024 Rocky Point UFSD 470 Application #240008017**

Pfaltz, Marianne

Mon 2/5/2024 11:45 AM

To:Van Cott, Christopher A.

;Reyes, Joseph

Cc:Tietjen, James

;Ciminelli, James

;Day, Diane

;Connolly, Elvira

 2 attachments (436 KB)

Rocky Point 470 240008017 E-Line.pdf; Rocky Point 470 240008017 IA Proposal.pdf;

**CAUTION:** This email originated from outside of our organization. Do not click links, open attachments or reply, unless you recognize the sender's email address and know the content is safe.

**~Rocky Point UFSD Technology Department~**

Good morning,

I have attached two of our E-Rate proposals for Rocky Point UFSD, which is in response to your 470 referenced above. The one proposal is for the E-Line broken down for 1, 3 and 5 year terms. The other proposal is for Internet Access Services for 1 Gig, 2 Gig and 3 Gig with and without DDoS for 1, 3 and 5 year terms. Once you have reviewed the proposals, after the ACD date, please check off your selections, initial the bottom of the forms and then return the electronic copies to me. Once I receive your selections, I will send you a 470 Contract that would need to be signed by your district Superintendent.

Thank you – I look forward to hearing back from you.

**Marianne Pfaltz**

Senior Account Clerk

Eastern Suffolk BOCES - RIC

750 Waverly Avenue

Holtsville, NY 11742

(631) 244-4259

Important: This electronic mail message and any attached files contain information intended for the exclusive use of the party or parties to whom it is addressed and may contain information that is proprietary, privileged, confidential and/or exempt from disclosure under applicable law. If you are not an intended recipient, you are hereby notified that any viewing, copying, disclosure or distribution of this information may be subject to legal restriction or sanction. Please notify the sender, by electronic mail or telephone, of any unintended recipients and delete the original message without making any copies.

# 470 Proposal



Eastern Suffolk BOCES - SPIN #143006632  
 750 Waverly Avenue  
 Holtsville, NY 11742  
 Phone (631) 244-4259  
 Email:

Date	February 1, 2024
District Contact	Christopher Van Cott
Email Address	
Phone	631-849-7564
470 Application #	240008017

District Customer
Rocky Point Union Free School District 90 Rocky Point-Yaphank Road Rocky Point, NY 11778

Quote/Project Description
Internet Access Services for the 2024-2025 School Year

	Description of Proposed Services	Term	Project			MARK (V) YOUR Selection
			Annual Cost *	Coordination Fee **	TOTAL ANNUAL COST	
Internet Services offered from Crown Castle <b>WITHOUT DDoS</b>	1 Gig Internet circuit <b>without DDoS</b>	1 year	\$11,796.00	\$1,769.40	\$13,565.40	
		3 year	\$11,100.00	\$1,665.00	\$12,765.00	X
		5 year	\$10,620.00	\$1,593.00	\$12,213.00	
	2 Gig Internet circuit <b>without DDoS</b>	1 year	\$20,412.00	\$3,061.80	\$23,473.80	
		3 year	\$19,200.00	\$2,880.00	\$22,080.00	
		5 year	\$18,372.00	\$2,755.80	\$21,127.80	
	3 Gig Internet circuit <b>without DDoS</b>	1 year	\$26,484.00	\$3,972.60	\$30,456.60	
		3 year	\$24,924.00	\$3,738.60	\$28,662.60	
		5 year	\$23,832.00	\$3,574.80	\$27,406.80	
Internet Services offered from Crown Castle <b>WITH DDoS</b>	1 Gig Internet circuit <b>with DDoS</b>	1 year	\$11,796.00	\$11,263.80	\$23,059.80	
		3 year	\$11,100.00	\$10,593.60	\$21,693.60	
		5 year	\$10,620.00	\$10,149.00	\$20,769.00	
	2 Gig Internet circuit <b>with DDoS</b>	1 year	\$20,412.00	\$19,497.60	\$39,909.60	
		3 year	\$19,200.00	\$18,336.00	\$37,536.00	
		5 year	\$18,372.00	\$17,549.40	\$35,921.40	
	3 Gig Internet circuit <b>with DDoS</b>	1 year	\$26,484.00	\$25,293.60	\$51,777.60	
		3 year	\$24,924.00	\$23,803.80	\$48,727.80	
		5 year	\$23,832.00	\$22,756.80	\$46,588.80	

\* Eligible Services  
 \*\* Ineligible Services

Please INITIAL form upon completion:

# 470 Proposal



Eastern Suffolk BOCES - SPIN #143006632  
 750 Waverly Avenue  
 Holtsville, NY 11742  
 Phone (631) 244-4259  
 Email: \_\_\_\_\_

Date	February 1, 2024
District Contact	Christopher Van Cott
Email Address	_____
Phone	631-849-7564
470 Application #	240008017

District Customer
Rocky Point Union Free School District 90 Rocky Point-Yaphank Road Rocky Point, NY 11778

Quote/Project Description
E-Line Services for the 2024-2025 School Year

	Description of Proposed Services	Term	Annual Cost *	Project Coordination Fee **	TOTAL ANNUAL COST	MARK (X) YOUR Selection
Internet Services offered from Crown Castle	100 MB E-Line	1 year	\$2,616.00	\$445.89	\$3,061.89	
		3 year	\$2,460.00	\$419.30	\$2,879.30	X
		5 year	\$2,352.00	\$400.89	\$2,752.89	
	1 Gb E-Line	1 year	\$6,132.00	\$1,045.18	\$7,177.18	
		3 year	\$5,772.00	\$983.82	\$6,755.82	X
		5 year	\$5,520.00	\$940.87	\$6,460.87	
	2 Gb E-Line	1 year	\$8,076.00	\$1,376.53	\$9,452.53	
		3 year	\$7,608.00	\$1,296.76	\$8,904.76	
		5 year	\$7,272.00	\$1,239.49	\$8,511.49	
	5 GB E-Line	1 year	\$9,612.00	\$1,638.34	\$11,250.34	
		3 year	\$9,036.00	\$1,540.16	\$10,576.16	
		5 year	\$8,652.00	\$1,474.71	\$10,126.71	
	10 Gb E-Line	1 year	\$12,144.00	\$2,069.91	\$14,213.91	
		3 year	\$11,424.00	\$1,947.19	\$13,371.19	
		5 year	\$10,932.00	\$1,863.33	\$12,795.33	

\* Eligible Services  
 \*\* Ineligible Services

Please INITIAL form upon completion:

**Verizon's response to Rocky Point Union Free Dist 2024 E-Rate 240008017**

Chaney, Steven M

Fri 2/2/2024 3:58 PM

To: Van Cott, Christopher A.

;Reyes, Joseph

3 attachments (273 KB)

PriceQuote-QQT-External-214310767-Rev0.pdf; PriceQuote-QQT-External-214310293-Rev0.pdf; PriceQuote-QQT-External-214310605-Rev0.pdf;

**CAUTION:** This email originated from outside of our organization. Do not click links, open attachments or reply, unless you recognize the sender's email address and know the content is safe.

**~Rocky Point UFSD Technology Department~**

Dear Chris,

Please accept the attached quote as Verizon's response to Rocky Point Union Free Dist's FY 2024 FCC Form 470 240008017. I will work with you to ensure your organization's technology needs are achieved.

In addition, Verizon offers end to end solutions that can be integrated into your organization. Learn more about the advantages of [Verizon's VoIP and Voice Services](#), [Network and Security solutions](#) or [MS Teams for Operator Connect](#). At Verizon, we take pride in delivering robust, reliable and cost effective solutions.

In accordance with the FCC's E-rate Eligible Services List (Miscellaneous): Taxes, surcharges, and other similar, reasonable charges incurred in obtaining eligible products or services are eligible. Unless itemized on the attached quote, prices quoted do not include applicable taxes, surcharges, or fees and should be estimated by the applicant when filing for E-rate funding.

Special Construction charges may be required when adding network infrastructure to ensure service delivery. When necessary, Verizon will request a network and facilities evaluation to determine any associated charges per site. These charges are not included in this quote but will be provided when applicable.

As with all E-rate awards, your Sales Executive should be notified to ensure your order is successfully received and processed to meet your installation requirements.

Should you have questions about the attached quote, please contact me at your earliest convenience.

Thank you,

SPIN 143001359

**Steven Chaney**Inside Sales Account Executive  
SLED Group  
M 912 531 2599

Please utilize the Verizon Enterprise Center at <https://enterprisecenter.verizon.com> to create, view or escalate a ticket or inquiry.



2/2/24, 4:10 PM

Mail - Van Cott, Christopher A. - Outlook

800-405-5339: Verizon Local repair

877-331-4276: Verizon Business Gov/Ed (GARM) Service Desk for repair issues

800-937-6000: Verizon Billing Customer Service

800-569-8799: Verizon Enterprise Center (VEC) Help Desk



<b>Master Customer Legal Entity:</b> New Customer		<b>Master Verizon Legal Entity:</b> MCI Communications Services LLC d/b/a Verizon Business Services	
<b>Customer Address:</b>	Missing Address!	<b>Quote Priced On:</b>	02 Feb 2024 20:54:03 UTC
<b>Account Manager:</b>	Steven Chaney	<b>Quote ID:</b>	214310767
	(813) 698-2872	<b>Quote Version #:</b>	0
<b>Created By:</b>	Steven Chaney	<b>Quote Expiration Date:</b>	02 May 2024
		<b>Contract ID:</b>	New

<b>Service(s) Included In Quote:</b> Access, Private IP (PIP), WAN Analysis Reporting	<b>Available Appendices (Additional Details and any Applicable Usage Tables):</b> Private IP (PIP)
<b>Note:</b> Items shown with "" are priced at time of Quote and require a Service Order Form document	

**Note:** 1 separate invoice(s) will be generated based on the Verizon Legal Entity, Customer Legal Entity, and currency combination(s) stated below. This may be a new or existing billing account number. Please review carefully to determine if changes are required. Changes after document signature will require a Transfer of Service Agreement or a new order.

**Note:** Verizon provides options to coordinate any intended disconnect when new installs are replacing an existing service, at no additional charge to the customer. If Customer does not choose for Verizon to coordinate any intended disconnect then Customer will be responsible for submitting the disconnect via the Verizon Enterprise Center along with any related billing overlap and Early Termination Charges per the contract. Please contact your account team to understand your choices.

**Quote Summary:**

Customer Legal Entity (CLE)	Entity Type	Customer Legal Entity Address:	Verizon Legal Entity (VLE)	CUR	MRC	NRC
New Customer	Contracting		MCI Communications Services LLC d/b/a Verizon Business Services	USD	1,144.00	0.00

	Activity Type	Quantity	Amount in Invoice Currency (USD)	
			MRC	NRC
<b>Location ID: 134900181C (Quote Location Name: Rocky Point)</b> 82 ROCKY POINT YAPHANK RD, ROCKY POINT, NY 11778-8422, United States				
<b>Access</b>				
Access, Service ID: 1619836557 * (VLE: MCI Communications Services LLC d/b/a Verizon Business Services) Added				
Service Commitment: 36 months				
Local Access - Op/App Performance: Gold / Silver - 100 Mbps - UNI				
Speed: 100 Mbps (FastE) - TPV UNI Speed: 100 Mbps (FastE) <sup>3</sup> N/A 380.00 0.00				
Additional Promotions Included: Verizon Services 90 Day Satisfaction Guarantee for Service <sup>1</sup> , E-Rate Early Term Liability Waiver <sup>2</sup>				
<b>Private IP (PIP)</b>				
Private IP (PIP), Service ID: 1619836561 * (VLE: MCI Communications Services LLC d/b/a Verizon Business Services) Added				
Related Service: Access 1619836557				
Service Commitment: 36 months				
PIP Port - 100 Mbps - United States <sup>3</sup> N/A 192.00 0.00				
Class of Service - ETM - 100 Mbps - 0 Kbps <sup>3</sup> N/A 0.00 0.00				
Additional Promotions Included: Verizon Services 90 Day Satisfaction Guarantee for Service <sup>1</sup> , E-Rate Early Term Liability Waiver <sup>2</sup>				
<b>WAN Analysis Reporting</b>				



	Activity Type	Quantity	Amount in Invoice Currency (USD)	
			MRC	NRC
<b>WAN Analysis Reporting, Service ID: 1619836563 * (VLE: MCI Communications Services LLC d/b/a Verizon Business Services)</b>				
Service Commitment: 36 months				
Standard Select	Added	N/A	0.00	N/A
Provider Edge Statistics		N/A	0.00	N/A
<b>Location Subtotal:</b>			<b>572.00</b>	<b>0.00</b>
<b>Location ID: 135772801C (Quote Location Name: Holtsville)</b>				
<b>750 WAVERLY AVE, HOLTSVILLE, NY 11742-1108, United States</b>				
<b>Access</b>				
<b>Access, Service ID: 1619836565 * (VLE: MCI Communications Services LLC d/b/a Verizon Business Services)</b>				
Service Commitment: 36 months				
Local Access - Op/App Performance: Gold / Silver - 100 Mbps - UNI	Added	N/A	380.00	0.00
Speed: 100 Mbps (FastE) - TPV UNI Speed: 100 Mbps (FastE) <sup>3</sup>		N/A		
Additional Promotions Included: Verizon Services 90 Day Satisfaction Guarantee for Service <sup>1</sup> , E-Rate Early Term Liability Waiver <sup>2</sup>				
<b>Private IP (PIP)</b>				
<b>Private IP (PIP), Service ID: 1619836569 * (VLE: MCI Communications Services LLC d/b/a Verizon Business Services)</b>				
Related Service: Access 1619836565				
Service Commitment: 36 months				
PIP Port - 100 Mbps - United States <sup>3</sup>	Added	N/A	192.00	0.00
Class of Service - ETM - 100 Mbps - 0 Kbps <sup>3</sup>		N/A	0.00	0.00
Additional Promotions Included: Verizon Services 90 Day Satisfaction Guarantee for Service <sup>1</sup> , E-Rate Early Term Liability Waiver <sup>2</sup>				
<b>WAN Analysis Reporting</b>				
<b>WAN Analysis Reporting, Service ID: 1619837051 * (VLE: MCI Communications Services LLC d/b/a Verizon Business Services)</b>				
Service Commitment: 36 months				
Standard Select	Added	N/A	0.00	N/A
Provider Edge Statistics		N/A	0.00	N/A
<b>Location Subtotal:</b>			<b>572.00</b>	<b>0.00</b>

- Customers who subscribe to Optimized Service(s) under a new Order to a new or existing Service Agreement may terminate any or all Optimized Services under such new Order at any time within 90 days of the Activation Date of such Service and avoid Early Termination Charges (Satisfaction Guarantee) by providing notice of termination to Verizon within the Satisfaction Guarantee period. Customers who terminate Optimized Service(s) under this Satisfaction Guarantee promotion must do so by providing notice in accordance with the Agreement and completing Verizon's standard form via the Verizon Enterprise Center (VEC) online portal at [verizonenterprise.com](http://verizonenterprise.com), as such URL may be updated from time to time. Customers who terminate Optimized Service(s) by invoking this Satisfaction Guarantee will be required to pay or refund Verizon, as applicable, in accordance with the clause entitled Consequences of Termination for Convenience of the Verizon online Master Terms, except for Early Termination Charges under the clause entitled Service Commitment.
- Subject to the Conditions, a Customer who orders eligible Optimized Services, may terminate such Optimized Services, at any time after the first 12 months of the Services Effective Date and avoid the Early Termination Charge for Service Termination by providing written notice of termination to Verizon. Customer must have a Form 470 (Description of Services Requested and Certification Form) posted to the USAC website to be eligible for this promotion.



**3 Service Commitment is subject to auto-renewal (unless customer opts out via Verizon Enterprise Center online portal) pursuant to customer's Agreement.**

This draft Quotation is for informational purposes only and is subject to change.

Verizon surcharges, fees and taxes are not included, may vary from month to month and are subject to change.

Pricing assumes the provision of accurate customer information. Provisioning is subject to order acceptance.

Pricing and provisioning are subject to the solution being deliverable and billable in accordance with negotiated terms and conditions including service level agreements which have been agreed upon by Verizon and the customer in writing.

DRAFT



## Appendix: Private IP (PIP)

Location ID: 134900181C (Quote Location Name: Rocky Point)  
82 ROCKY POINT YAPHANK RD, ROCKY POINT, NY 11778-8422, United States

Service ID: 1819836561 (VLE: MCI Communications Services LLC d/b/a Verizon Business Services)

Private IP Dynamic Port Pricing	
Port Speed	MRC (USD)
1 Mbps	38.00
2 Mbps	56.00
3 Mbps	70.00
4 Mbps	84.00
5 Mbps	93.00
6 Mbps	96.00
7 Mbps	97.00
8 Mbps	98.00
9 Mbps	99.00
10 Mbps	100.00

Private IP Dynamic Port Pricing	
Port Speed	MRC (USD)
15 Mbps	138.00
20 Mbps	144.00
30 Mbps	150.00
40 Mbps	156.00
50 Mbps	162.00
60 Mbps	168.00
70 Mbps	174.00
80 Mbps	180.00
90 Mbps	186.00
100 Mbps	192.00

Private IP EF Real-time Pricing	
EF Realtime CAR Speed	MRC (USD)
0 Kbps	0.00
8 Kbps	3.00
16 Kbps	3.00
32 Kbps	3.00
56 Kbps	3.00
128 Kbps	3.00
256 Kbps	3.00
384 Kbps	3.00
512 Kbps	3.00
768 Kbps	3.00
900 Kbps	3.00
1 Mbps	3.00
1.3 Mbps	3.00
1.5 Mbps	3.00
1.7 Mbps	3.00
2 Mbps	16.00
2.5 Mbps	18.00
3 Mbps	20.00
3.5 Mbps	21.00
4 Mbps	23.00

Private IP EF Real-time Pricing	
EF Realtime CAR Speed	MRC (USD)
4.5 Mbps	24.00
5 Mbps	25.00
5.5 Mbps	27.00
7 Mbps	30.00
9 Mbps	33.00
10 Mbps	34.00
13 Mbps	43.00
14 Mbps	46.00
15 Mbps	49.00
17 Mbps	53.00
18 Mbps	54.00
20 Mbps	59.00
25 Mbps	64.00
30 Mbps	69.00
35 Mbps	71.00
40 Mbps	73.00
45 Mbps	77.00
50 Mbps	82.00
70 Mbps	107.00
90 Mbps	125.00



## Appendix: Private IP (PIP)

Location ID: 135772801C (Quote Location Name: Holtsville)  
750 WAVERLY AVE, HOLTSMILLE, NY 11742-1108, United States

Service ID: 1619836569 (VLE: MCI Communications Services LLC d/b/a Verizon Business Services)

Private IP Dynamic Port Pricing	
Port Speed	MRC (USD)
1 Mbps	38.00
2 Mbps	56.00
3 Mbps	70.00
4 Mbps	84.00
5 Mbps	93.00
6 Mbps	96.00
7 Mbps	97.00
8 Mbps	98.00
9 Mbps	99.00
10 Mbps	100.00

Private IP Dynamic Port Pricing	
Port Speed	MRC (USD)
15 Mbps	138.00
20 Mbps	144.00
30 Mbps	150.00
40 Mbps	158.00
50 Mbps	162.00
60 Mbps	168.00
70 Mbps	174.00
80 Mbps	180.00
90 Mbps	186.00
100 Mbps	192.00

Private IP EF Real-time Pricing	
EF Realtime CAR Speed	MRC (USD)
0 Kbps	0.00
8 Kbps	3.00
16 Kbps	3.00
32 Kbps	3.00
56 Kbps	3.00
128 Kbps	3.00
256 Kbps	3.00
384 Kbps	3.00
512 Kbps	3.00
768 Kbps	3.00
900 Kbps	3.00
1 Mbps	3.00
1.3 Mbps	3.00
1.5 Mbps	3.00
1.7 Mbps	3.00
2 Mbps	18.00
2.5 Mbps	18.00
3 Mbps	20.00
3.5 Mbps	21.00
4 Mbps	23.00

Private IP EF Real-time Pricing	
EF Realtime CAR Speed	MRC (USD)
4.5 Mbps	24.00
5 Mbps	25.00
5.5 Mbps	27.00
7 Mbps	30.00
9 Mbps	33.00
10 Mbps	34.00
13 Mbps	43.00
14 Mbps	48.00
15 Mbps	49.00
17 Mbps	53.00
18 Mbps	54.00
20 Mbps	59.00
25 Mbps	64.00
30 Mbps	69.00
35 Mbps	71.00
40 Mbps	73.00
45 Mbps	77.00
50 Mbps	82.00
70 Mbps	107.00
80 Mbps	125.00



<b>Master Customer Legal Entity:</b> New Customer		<b>Master Verizon Legal Entity:</b> MCI Communications Services LLC d/b/a Verizon Business Services	
<b>Customer Address:</b>	Missing Address!	<b>Quote Priced On:</b>	02 Feb 2024 20:37:21 UTC
<b>Account Manager:</b>	Steven Chaney	<b>Quote ID:</b>	214310293
	(813) 698-2872	<b>Quote Version #:</b>	0
<b>Created By:</b>	Steven Chaney	<b>Quote Expiration Date:</b>	02 May 2024
		<b>Contract ID:</b>	New

<b>Service(s) Included In Quote:</b> Access, CPE, Internet Dedicated Services	<b>Available Appendices (Additional Details and any Applicable Usage Tables):</b> Internet Dedicated Services
<b>Note:</b> Items shown with "" are priced at time of Quote and require a Service Order Form document	

**Note:** 1 separate invoice(s) will be generated based on the Verizon Legal Entity, Customer Legal Entity, and currency combination(s) stated below. This may be a new or existing billing account number. Please review carefully to determine if changes are required. Changes after document signature will require a Transfer of Service Agreement or a new order.

**Note:** Verizon provides options to coordinate any intended disconnect when new installs are replacing an existing service, at no additional charge to the customer. If Customer does not choose for Verizon to coordinate any intended disconnect then Customer will be responsible for submitting the disconnect via the Verizon Enterprise Center along with any related billing overlap and Early Termination Charges per the contract. Please contact your account team to understand your choices.

<b>Quote Summary:</b>						
<b>Customer Legal Entity (CLE)</b>	<b>Entity Type</b>	<b>Customer Legal Entity Address:</b>	<b>Verizon Legal Entity (VLE)</b>	<b>CUR</b>	<b>MRC</b>	<b>NRC</b>
New Customer	Contracting		MCI Communications Services LLC d/b/a Verizon Business Services	USD	885.78	89.88

	Activity Type	Quantity	Amount In Invoice Currency (USD)	
			MRC	NRC
<b>Location ID: 134900181C (Quote Location Name: Rocky Point)</b> 82 ROCKY POINT YAPHANK RD, ROCKY POINT, NY 11778-8422, United States				
<b>Access</b>				
Access, Service ID: 1619834193 * (VLE: MCI Communications Services LLC d/b/a Verizon Business Services) Added				
Service Commitment: 36 months				
Local Access - Op/App Performance: Gold / Silver - 1 Gbps - UNI Speed: 1 Gbps (GigE) - TPV UNI Speed: 1 Gbps (GigE) <sup>3</sup>				
N/A 448.00 0.00				
Additional Promotions Included: E-Rate Early Term Liability Waiver <sup>1</sup> , Verizon Services 90 Day Satisfaction Guarantee for Service <sup>2</sup>				
<b>CPE</b>				
CPE, Service ID(s): See CPE Appendix* (VLE: MCI Communications Services LLC d/b/a Verizon Business Services) See CPE Appendix				
Service Commitment: See CPE Appendix				
Customer Premises Equipment and Related Services N/A 205.78 89.88				
<b>Internet Dedicated Services</b>				
Internet Dedicated Services, Service ID: 1619834197 * (VLE: MCI Communications Services LLC d/b/a Verizon Business Services) Added				
Related Service: Access 1619834193				
Service Commitment: 36 months				



	Activity Type	Quantity	Amount in Invoice Currency (USD)	
			MRC	NRC
Internet Port - Tiered - 1 Gbps - United States of America <sup>3</sup>		N/A	232.00	0.00
Additional Promotions Included: E-Rate Early Term Liability Waiver <sup>1</sup> , Verizon Services 90 Day Satisfaction Guarantee for Service <sup>2</sup>				
<b>Location Subtotal:</b>			<b>885.78</b>	<b>89.88</b>

- 1 Subject to the Conditions, a Customer who orders eligible Optimized Services, may terminate such Optimized Services, at any time after the first 12 months of the Services Effective Date and avoid the Early Termination Charge for Service Termination by providing written notice of termination to Verizon. Customer must have a Form 470 (Description of Services Requested and Certification Form) posted to the USAC website to be eligible for this promotion.
- 2 Customers who subscribe to Optimized Service(s) under a new Order to a new or existing Service Agreement may terminate any or all Optimized Services under such new Order at any time within 90 days of the Activation Date of such Service and avoid Early Termination Charges (Satisfaction Guarantee) by providing notice of termination to Verizon within the Satisfaction Guarantee period. Customers who terminate Optimized Service(s) under this Satisfaction Guarantee promotion must do so by providing notice in accordance with the Agreement and completing Verizon's standard form via the Verizon Enterprise Center (VEC) online portal at [verizonenterprise.com](http://verizonenterprise.com), as such URL may be updated from time to time. Customers who terminate Optimized Service(s) by invoking this Satisfaction Guarantee will be required to pay or refund Verizon, as applicable, in accordance with the clause entitled Consequences of Termination for Convenience of the Verizon online Master Terms, except for Early Termination Charges under the clause entitled Service Commitment.
- 3 Service Commitment is subject to auto-renewal (unless customer opts out via Verizon Enterprise Center online portal) pursuant to customer's Agreement.

This draft Quotation is for informational purposes only and is subject to change.

Verizon surcharges, fees and taxes are not included, may vary from month to month and are subject to change.

Pricing assumes the provision of accurate customer information. Provisioning is subject to order acceptance.

Pricing and provisioning are subject to the solution being deliverable and billable in accordance with negotiated terms and conditions including service level agreements which have been agreed upon by Verizon and the customer in writing.





## Appendix: Internet Dedicated Services

Location ID: 134900181C (Quote Location Name: Rocky Point)  
82 ROCKY POINT YAPHANK RD, ROCKY POINT, NY 11778-8422, United States

Service ID: 1619834197 (VLE: MCI Communications Services LLC d/b/a Verizon Business Services)

Internet Dedicated Dynamic Port Pricing	
Port Speed	MRC (USD)
2 Mbps	57.00
3 Mbps	57.00
4 Mbps	57.00
5 Mbps	57.00
8 Mbps	61.00
10 Mbps	61.00
20 Mbps	64.00
30 Mbps	70.00
40 Mbps	78.00
50 Mbps	80.00
60 Mbps	86.00
70 Mbps	112.00

Internet Dedicated Dynamic Port Pricing	
Port Speed	MRC (USD)
80 Mbps	128.00
100 Mbps	136.00
150 Mbps	185.00
200 Mbps	200.00
300 Mbps	206.00
400 Mbps	212.00
500 Mbps	217.00
600 Mbps	224.00
700 Mbps	230.00
800 Mbps	233.00
1 Gbps	232.00



<b>Master Customer Legal Entity:</b> New Customer		<b>Master Verizon Legal Entity:</b> MCI Communications Services LLC d/b/a Verizon Business Services	
<b>Customer Address:</b>	Missing Address!	<b>Quote Priced On:</b>	02 Feb 2024 20:47:06 UTC
<b>Account Manager:</b>	Steven Chaney	<b>Quote ID:</b>	214310605
	(813) 698-2872	<b>Quote Version #:</b>	0
<b>Created By:</b>	Steven Chaney	<b>Quote Expiration Date:</b>	02 May 2024
		<b>Contract ID:</b>	New

**Service(s) Included In Quote:** Access, Private IP (PIP), WAN Analysis Reporting  
**Note:** Items shown with \*\*\* are priced at time of Quote and require a Service Order Form document

**Available Appendices (Additional Details and any Applicable Usage Tables):** Private IP (PIP)

**Note:** 1 separate invoice(s) will be generated based on the Verizon Legal Entity, Customer Legal Entity, and currency combination(s) stated below. This may be a new or existing billing account number. Please review carefully to determine if changes are required. Changes after document signature will require a Transfer of Service Agreement or a new order.

**Note:** Verizon provides options to coordinate any intended disconnect when new installs are replacing an existing service, at no additional charge to the customer. If Customer does not choose for Verizon to coordinate any intended disconnect then Customer will be responsible for submitting the disconnect via the Verizon Enterprise Center along with any related billing overlap and Early Termination Charges per the contract. Please contact your account team to understand your choices.

**Quote Summary:**

Customer Legal Entity (CLE)	Entity Type	Customer Legal Entity Address:	Verizon Legal Entity (VLE)	CUR	MRC	NRC
New Customer	Contracting		MCI Communications Services LLC d/b/a Verizon Business Services	USD	2,178.00	0.00

	Activity Type	Quantity	Amount In Invoice Currency (USD)	
			MRC	NRC
<b>Location ID: 134900181C (Quote Location Name: Rocky Point)</b> 82 ROCKY POINT YAPHANK RD, ROCKY POINT, NY 11778-8422, United States				
<b>Access</b>				
Access, Service ID: 1619835523 * (VLE: MCI Communications Services LLC d/b/a Verizon Business Services) Added				
Service Commitment: 36 months				
Local Access - Op/App Performance: Gold / Silver - 1 Gbps - UNI Speed: 1 Gbps (GigE) - TPV UNI Speed: 1 Gbps (GigE) <sup>3</sup>				
		N/A	448.00	0.00
Additional Promotions Included: E-Rate Early Term Liability Waiver <sup>1</sup> , Verizon Services 90 Day Satisfaction Guarantee for Service <sup>2</sup>				
<b>Private IP (PIP)</b>				
Private IP (PIP), Service ID: 1619835527 * (VLE: MCI Communications Services LLC d/b/a Verizon Business Services) Added				
Related Service: Access 1619835523				
Service Commitment: 36 months				
	PIP Port - 1 Gbps - United States <sup>3</sup>	N/A	641.00	0.00
	Class of Service - ETM - 1 Gbps - 0 Kbps <sup>3</sup>	N/A	0.00	0.00
Additional Promotions Included: E-Rate Early Term Liability Waiver <sup>1</sup> , Verizon Services 90 Day Satisfaction Guarantee for Service <sup>2</sup>				
<b>WAN Analysis Reporting</b>				



	Activity Type	Quantity	Amount in Invoice Currency (USD)	
			MRC	NRC
<b>WAN Analysis Reporting, Service ID: 1619835529 * (VLE: MCI Communications Services LLC d/b/a Verizon Business Services)</b>				
Service Commitment: 36 months				
	Standard Select	N/A	0.00	N/A
	Provider Edge Statistics	N/A	0.00	N/A
<b>Location Subtotal:</b>			<b>1,089.00</b>	<b>0.00</b>
<b>Location ID: 135772663C (Quote Location Name: Rocky Point)</b>				
<b>525 RT 25A, ROCKY POINT, NY 11778-8885, United States</b>				
<b>Access</b>				
<b>Access, Service ID: 1619835691 * (VLE: MCI Communications Services LLC d/b/a Verizon Business Services)</b>				
Service Commitment: 36 months				
	Local Access - Op/App Performance: Gold / Silver - 1 Gbps - UNI Speed: 1 Gbps (GigE) - TPV UNI Speed: 1 Gbps (GigE) <sup>3</sup>	N/A	448.00	0.00
Additional Promotions Included: E-Rate Early Term Liability Waiver <sup>1</sup> , Verizon Services 90 Day Satisfaction Guarantee for Service <sup>2</sup>				
<b>Private IP (PIP)</b>				
<b>Private IP (PIP), Service ID: 1619835695 * (VLE: MCI Communications Services LLC d/b/a Verizon Business Services)</b>				
Related Service: Access 1619835691				
Service Commitment: 36 months				
	PIP Port - 1 Gbps - United States <sup>3</sup>	N/A	641.00	0.00
	Class of Service - ETM - 1 Gbps - 0 Kbps <sup>3</sup>	N/A	0.00	0.00
Additional Promotions Included: E-Rate Early Term Liability Waiver <sup>1</sup> , Verizon Services 90 Day Satisfaction Guarantee for Service <sup>2</sup>				
<b>WAN Analysis Reporting</b>				
<b>WAN Analysis Reporting, Service ID: 1619835697 * (VLE: MCI Communications Services LLC d/b/a Verizon Business Services)</b>				
Service Commitment: 36 months				
	Standard Select	N/A	0.00	N/A
	Provider Edge Statistics	N/A	0.00	N/A
<b>Location Subtotal:</b>			<b>1,089.00</b>	<b>0.00</b>

- 1 Subject to the Conditions, a Customer who orders eligible Optimized Services, may terminate such Optimized Services, at any time after the first 12 months of the Services Effective Date and avoid the Early Termination Charge for Service Termination by providing written notice of termination to Verizon. Customer must have a Form 470 (Description of Services Requested and Certification Form) posted to the USAC website to be eligible for this promotion.
- 2 Customers who subscribe to Optimized Service(s) under a new Order to a new or existing Service Agreement may terminate any or all Optimized Services under such new Order at any time within 90 days of the Activation Date of such Service and avoid Early Termination Charges (Satisfaction Guarantee) by providing notice of termination to Verizon within the Satisfaction Guarantee period. Customers who terminate Optimized Service(s) under this Satisfaction Guarantee promotion must do so by providing notice in accordance with the Agreement and completing Verizon's standard form via the Verizon Enterprise Center (VEC) online portal at verizonenterprise.com, as such URL may be updated from time to time. Customers who terminate Optimized Service(s) by invoking this Satisfaction Guarantee will be required to pay or refund Verizon, as applicable, in accordance with the clause entitled Consequences of Termination for Convenience of the Verizon online Master Terms, except for Early Termination Charges under the clause entitled Service Commitment.



**3 Service Commitment is subject to auto-renewal (unless customer opts out via Verizon Enterprise Center online portal) pursuant to customer's Agreement.**

This draft Quotation is for informational purposes only and is subject to change.

Verizon surcharges, fees and taxes are not included, may vary from month to month and are subject to change.

Pricing assumes the provision of accurate customer information. Provisioning is subject to order acceptance.

Pricing and provisioning are subject to the solution being deliverable and billable in accordance with negotiated terms and conditions including service level agreements which have been agreed upon by Verizon and the customer in writing.



## Appendix: Private IP (PIP)

Location ID: 134900181C (Quote Location Name: Rocky Point)  
82 ROCKY POINT YAPHANK RD, ROCKY POINT, NY 11778-8422, United States

Service ID: 1619835527 (VLE: MCI Communications Services LLC d/b/a Verizon Business Services)

Private IP Dynamic Port Pricing	
Port Speed	MRC (USD)
1 Mbps	38.00
2 Mbps	56.00
3 Mbps	70.00
4 Mbps	84.00
5 Mbps	93.00
6 Mbps	96.00
7 Mbps	97.00
8 Mbps	98.00
9 Mbps	99.00
10 Mbps	100.00
15 Mbps	138.00
20 Mbps	144.00
30 Mbps	150.00
40 Mbps	156.00

Private IP Dynamic Port Pricing	
Port Speed	MRC (USD)
50 Mbps	162.00
60 Mbps	168.00
70 Mbps	174.00
80 Mbps	180.00
90 Mbps	186.00
100 Mbps	192.00
150 Mbps	284.00
200 Mbps	375.00
300 Mbps	507.00
400 Mbps	539.00
500 Mbps	563.00
600 Mbps	592.00
800 Mbps	621.00
1 Gbps	641.00

Private IP EF Real-time Pricing	
EF Realtime CAR Speed	MRC (USD)
0 Kbps	0.00
8 Kbps	3.00
16 Kbps	3.00
32 Kbps	3.00
56 Kbps	3.00
128 Kbps	3.00
256 Kbps	3.00
384 Kbps	3.00
512 Kbps	3.00
768 Kbps	3.00
900 Kbps	3.00
1 Mbps	3.00
1.3 Mbps	3.00
1.5 Mbps	3.00
1.7 Mbps	3.00
2 Mbps	16.00
2.5 Mbps	18.00
3 Mbps	20.00
3.5 Mbps	21.00
4 Mbps	23.00

Private IP EF Real-time Pricing	
EF Realtime CAR Speed	MRC (USD)
14 Mbps	46.00
15 Mbps	49.00
17 Mbps	53.00
18 Mbps	54.00
20 Mbps	59.00
25 Mbps	64.00
30 Mbps	69.00
35 Mbps	71.00
40 Mbps	73.00
45 Mbps	77.00
50 Mbps	82.00
70 Mbps	107.00
90 Mbps	125.00
110 Mbps	148.00
140 Mbps	181.00
150 Mbps	184.00
180 Mbps	201.00
200 Mbps	209.00
250 Mbps	224.00
350 Mbps	263.00



**Appendix: Private IP (PIP)**

Private IP EF Real-time Pricing	
EF Realtime CAR Speed	MRC (USD)
4.5 Mbps	24.00
5 Mbps	25.00
5.5 Mbps	27.00
7 Mbps	30.00
9 Mbps	33.00
10 Mbps	34.00
13 Mbps	43.00

Private IP EF Real-time Pricing	
EF Realtime CAR Speed	MRC (USD)
400 Mbps	290.00
450 Mbps	302.00
500 Mbps	321.00
550 Mbps	344.00
700 Mbps	375.00
900 Mbps	418.00

Location ID: 135772663C (Quote Location Name: Rocky Point)  
 525 RT 25A, ROCKY POINT, NY 11778-8885, United States

Service ID: 1619835895 (VLE: MCI Communications Services LLC d/b/a Verizon Business Services)

Private IP Dynamic Port Pricing	
Port Speed	MRC (USD)
1 Mbps	38.00
2 Mbps	56.00
3 Mbps	70.00
4 Mbps	84.00
5 Mbps	93.00
6 Mbps	96.00
7 Mbps	97.00
8 Mbps	98.00
9 Mbps	99.00
10 Mbps	100.00
15 Mbps	138.00
20 Mbps	144.00
30 Mbps	150.00
40 Mbps	156.00

Private IP Dynamic Port Pricing	
Port Speed	MRC (USD)
50 Mbps	162.00
60 Mbps	168.00
70 Mbps	174.00
80 Mbps	180.00
90 Mbps	186.00
100 Mbps	192.00
150 Mbps	284.00
200 Mbps	375.00
300 Mbps	507.00
400 Mbps	539.00
500 Mbps	563.00
600 Mbps	592.00
800 Mbps	621.00
1 Gbps	641.00

Private IP EF Real-time Pricing	
EF Realtime CAR Speed	MRC (USD)
0 Kbps	0.00
8 Kbps	3.00
16 Kbps	3.00
32 Kbps	3.00
56 Kbps	3.00
128 Kbps	3.00
256 Kbps	3.00
384 Kbps	3.00

Private IP EF Real-time Pricing	
EF Realtime CAR Speed	MRC (USD)
14 Mbps	46.00
15 Mbps	49.00
17 Mbps	53.00
18 Mbps	54.00
20 Mbps	59.00
25 Mbps	64.00
30 Mbps	69.00
35 Mbps	71.00



### Appendix: Private IP (PIP)

Private IP EF Real-time Pricing	
EF Realtime CAR Speed	MRC (USD)
512 Kbps	3.00
768 Kbps	3.00
900 Kbps	3.00
1 Mbps	3.00
1.3 Mbps	3.00
1.5 Mbps	3.00
1.7 Mbps	3.00
2 Mbps	16.00
2.5 Mbps	18.00
3 Mbps	20.00
3.5 Mbps	21.00
4 Mbps	23.00
4.5 Mbps	24.00
5 Mbps	25.00
5.5 Mbps	27.00
7 Mbps	30.00
9 Mbps	33.00
10 Mbps	34.00
13 Mbps	43.00

Private IP EF Real-time Pricing	
EF Realtime CAR Speed	MRC (USD)
40 Mbps	73.00
45 Mbps	77.00
50 Mbps	82.00
70 Mbps	107.00
90 Mbps	125.00
110 Mbps	148.00
140 Mbps	181.00
150 Mbps	184.00
180 Mbps	201.00
200 Mbps	209.00
250 Mbps	224.00
350 Mbps	283.00
400 Mbps	290.00
450 Mbps	302.00
500 Mbps	321.00
550 Mbps	344.00
700 Mbps	375.00
800 Mbps	418.00

BRIDGE

## 24 Rocky Point C1 240008017

John Naughton

Tue 2/13/2024 9:21 AM

To: Van Cott, Christopher A.

Cc: Reyes, Joseph

 1 attachments (9 MB)

DNS 470 Response Rocky Point.pdf;

**CAUTION:** This email originated from outside of our organization. Do not click links, open attachments or reply, unless you recognize the sender's email address and know the content is safe.

**~Rocky Point UFSD Technology Department~**

Good Afternoon Christopher,

We are pleased to submit our proposal for Form 240008017. DNS has provided E-rate solutions for schools for over 20 years and look forward to you helping you to reach your goals. If you have any questions or need any changes made to the quote, please feel free to contact me.

DNS offers a variety of other services as well such as Cellular signal boosting, VoIP phone systems, SIP Trunking, Windstream replacements, AT&T LTE mobility and much more. Please feel free to reach out with any questions about the proposal or to ask about how DNS can help you with any of your telecommunication needs.

Best,

**Jack Naughton**

Sales Account Representative

Business Automation Technologies, Inc.

dba Data Network Solutions SPIN 143009866

Voice, Unified Communications & Collaboration Solutions ESCNJ 20/21-30

732 756 0298 (O)

732 673 0632 (m)





Data  
Network  
Solutions

# Price Quote & Profile

Connecting you to the world,  
one solution at a time.

5G

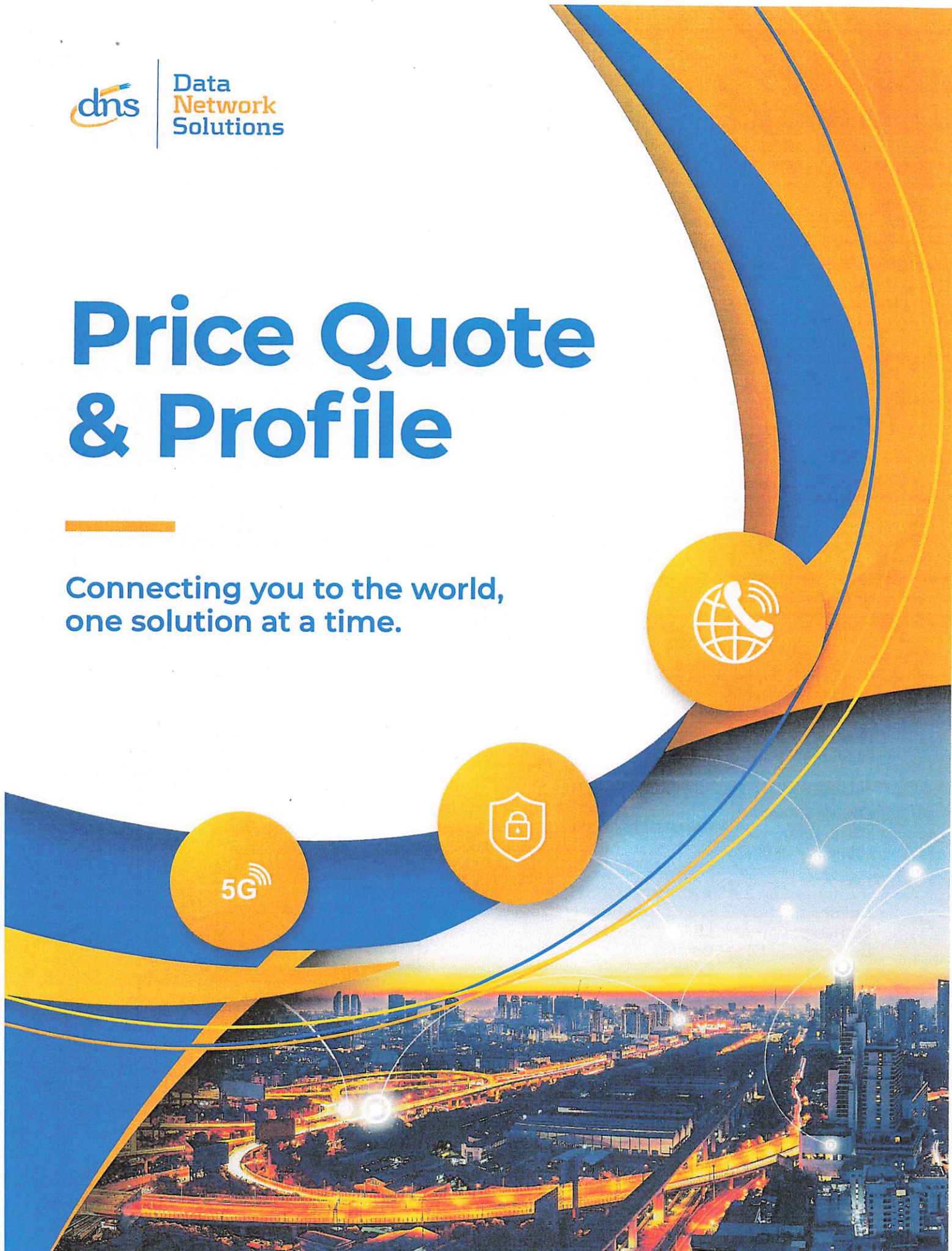



Data  
Network  
Solutions



Get in touch:

**800 649 6741**

116 Oceanport Ave  
Little Silver, NJ 07739

sales@dnetworksolution.com

www.dnetworksolution.com

SPIN # 143009866

FCC Registered Business name Business Automation Technologies, Inc, d/b/a Data Network Solutions.

Date: February 12, 2023

ROCKY POINT UNION FREE DIST  
90 ROCKY POINT-YAPHANK ROAD  
ROCKY POINT, NY 11778

The following proposal expresses our interest in providing dedicated lit fiber Internet access delivered to Rocky Point Union SD. DDoS pricing attached. The term is for 36 Months with a June 1, 2024 service start date.

DNS will comply with all the requirements listed in the 470 # 240008017 without exception. There will be no increased pricing during the contract term. Your district may increase bandwidth during contracted term, which will lead to an increase of price according to proposed price schedule.

**DNS is a suitable candidate for this 470 solicitation due to the following reasons:**

- Successfully provided Broadband, Telecommunications, Cloud Hosting, and call center solutions to educational institutions, government agencies, and the private sector since 1999.
- One of the very few carriers awarded by the ESCNJ Cooperative, providing Traditional Voice, Data, Hosted Voice and other telecom services.
- Authorized by the New Jersey Board Public Utilities since 2003 as a Competitive Local Exchange Carrier (CLEC) in New Jersey and the Public Service Commissions in New York and Pennsylvania.
- Awarded a White House Communications Small Business Contract.
- Belongs to the NYIIC & DE-CIX peering exchanges, providing more direct connections to the websites your district uses most.
- Includes advanced Internet monitoring that allows insights into and troubleshooting of the districts Internet usage not available elsewhere.
- 24/7 data centers including Microsoft and Cisco trained staffed in New Jersey and Pennsylvania to support and manage client services that is equipped with generator power backup, physical security, and around the clock operation.
- Remotely monitors, diagnoses, and troubleshoots client networks for Traditional Voice, Data, Internet and Hosted Applications, and if the issue cannot be resolved remotely, will make an on-site visit.

Thank you for your time and attention,

**Isaac Fajerman**  
President



# Data Network Solutions

## Price Quote from DNS

116 Oceanport Ave  
Little Silver, NJ 07739  
(732) 741-5889 (800) 649-6741  
Fax (732) 747-3584  
[www.dnetworksolution.com](http://www.dnetworksolution.com)

NY STATE APPROVED  
Tariff No. 1  
SPIN # 143009866

"Reliable Phone & Secure Internet Services"

<b>Customer Information</b>		Form 470 Application Number:	240008017
Name:	ROCKY POINT UNION FREE DIST	Date	2/13/2024
Address:	90 ROCKY POINT-YAPHANK ROAD	Rep	John Naughton
City/St/Zip:	ROCKY POINT, NY 11778	Rep #	7327560298
Contact:	Christopher Van Cott	Rep Email	
Phone:	631-849-7564	Order Type	New
Email:		Terms	36 Month Contract From July 1, 2024 Install Date

### Monthly Recurring Services

Item	Description	QTY.	Monthly Price	Select
<b>Direct Internet Access Fiber Connection with Peering</b>				
<b>Service Request #1 - Dedicated Internet Access</b>				
<b>82 Rocky Point-Yaphank Road, Rocky Point, NY 11778</b>				
1	1 Ge Dedicated Internet	1	\$ 1,090.00	Select
2	2 Ge Dedicated Internet	1	\$ 1,590.00	Select
3	3 Ge Dedicated Internet	1	\$ 1,790.00	Select
4	/31 IP Block	1	NO COST	Select
No other taxes or fees apply				
Voice Service Bundles Available				
Ask about our NetScout DDOS Services				
DNS provides mobile ATT or Verizon 5G boosters				
DNS can replace expensive fiber with mmWave Wireless point to point connections				
DNS is eligible for Affordable Connectivity Program				
DNS can provide carrier agnostic Cell Phone Boosters				
SPAC OMB Control No. 3060 - 0856 10-2921				
We offer both SPI and BEAR invoicing				
Annual Renewals Available				
Description		QTY.	Unit Price	Total
Installation		1	\$1,000.00	Waived

**Total Internet Monthly Recurring: select**

**Total Non-Recurring: waived**

Approved By Signature: \_\_\_\_\_ Date \_\_\_\_\_

Print Name: \_\_\_\_\_ Title \_\_\_\_\_

THANK YOU FOR DOING BUSINESS WITH US!



## References

This reference list is for the sole use of the intended recipient(s) and contains confidential and privileged information. Any unauthorized review, use, disclosure or distribution is prohibited. If you are not the intended recipient, please contact the below author by reply email and destroy all copies of the original message. Below are references to verify our long-standing excellent customer service:

International House Columbia Univ.  
**Brian Hermosura**  
*Director of Information Technology*

(212) 316-8488

- Since 2012
- 1 GB Dedicated Fiber Internet with Peering

Northside Center for Child Development  
**Leo Genn**  
*Special Project Coordinator*  
(212) 426-3406

- Voice Services at 3 Sites: Brooklyn, Manhattan & Bronx
- Since 2018

Brooklyn Prospect Charter School  
**David Casapao**  
*Director of Technology*

(646) 483-4532

- Fiber 1Gb Internet
- Since 2020



**Isaac Fajerman**  
President



# Monitoring Service & Support



DNS will provide a **Project Manager** to oversee project from start to finish. They will be responsible for scheduling status meetings and managing resources as needed to ensure timely completion.

## Need help?

### 1. Trouble Ticket Submission

- To generate a trouble ticket—
  - a) Email [techsupport@dnetworksolution.com](mailto:techsupport@dnetworksolution.com) directly
  - b) Call **(800) 649-6741**
  - c) Utilize network monitoring tools
  - d) Utilize the web browser portal
- Ticket numbers are automatically created or customer can request that the ticket number reflect internal trouble ticket.
- 3 levels of ticket escalation are available.

### 2. Service Response

- A service technician will be assigned to the customer's trouble ticket within one hour of submission.
- A support engineer will be dispatched within, if needed, no more than 4 hours from when the initial trouble is reported.
- The issue will be troubleshot, diagnosed, and solved remotely.

### 3. Problem Resolution

- The trouble ticket is closed when customer confirms successful repair.
- The ticket auto-close can be implemented at customer's request—
  - a) If they are unsure the problem will return.
  - b) If it is unclear if repair was successful.



## Internet and/or Voice Service Level Agreement (SLA)

Data Network Solutions the SERVICE PROVIDER shall provide, Outage Notification Guarantee, Latency Guarantee, and/or Packet Loss Guarantee as defined below. DNS maintain real time analytic software to monitor the performance of the customer connected services. As part of any troubleshooting DNS shall run reports and cooperate with the customer to analyze and isolate the source of any trouble.

**A. Network Availability Guarantee.** SERVICE PROVIDER guarantees 99.99% network up time. Any Customer who experiences total network unavailability in excess of .1% in a calendar month measured in minutes shall receive service credit of (1) week. Unavailability in excess of .2% in a (2) consecutive calendar months measured in minutes shall receive service credit of (2) weeks.

**B. Outage Notification Guarantee.** SERVICE PROVIDER Guarantees that it shall contact Customer, either by phone or email, within (1) hour after the occurrence of a network unavailability resulting in complete downtime. If SERVICE PROVIDER fails to contact within (1) hour after the occurrence of network unavailability, Customer shall receive one-day service credit.

**C. Circuit Latency Guarantee.** Customer who experiences Latency in excess of 55 milliseconds average in (1) calendar month shall receive service credit as outline below.

Latency in excess of 55 milliseconds in (1) calendar month – (1) week service credit.

Latency in excess of 55 milliseconds in each of (2) consecutive calendar months– (2) weeks service credit.

**D. Packet Loss Guarantee.** SERVICE PROVIDER guarantees that packet loss shall not be more than 1% percent during any calendar month shall receive a (1) day service credit.

**E. Jitter Guarantee.** Internet SERVICE PROVIDER guarantees less than 5msec jitter. Any Customer who experiences jitter in excess of 5msec in (1) calendar month measured in minutes shall receive service credit of (1) week. Unavailability in excess of 5msec in a (2) consecutive calendar months measured in minutes shall receive service credit of (2) weeks.

**F. Mean Opinion Score Guarantee.** SERVICE PROVIDER guarantees a mean opinion score above 3.8. Any Customer who experiences a mean opinion score below 3.8 in a calendar month measured in minutes shall receive service credit of (1) week. A mean opinion score below 3.8 below in a (2) consecutive calendar months measured in minutes shall receive service credit of (2) weeks.

**G. Denial of Service Attacks.** SERVICE PROVIDER guarantees it has an active a Denial of Service prevention plan including detection and response procedures. Any Customer who experiences Denial of Service Attack in excess of (4) hours in (1) calendar month measured in minutes shall receive service credit of (1) week. Unavailability in excess of (4) hours in a (2) consecutive calendar months measured in minutes shall receive service credit of (2) weeks.

**H. 24/7 Access to Technical Support.** SERVICE PROVIDER guarantees customer access to a service engineer or manager with a toll free number and email 24/7. Any Customer who experiences no response in excess of (4) hours in (1) calendar month measured in minutes shall receive service credit of (1) week. Unavailability in excess of (4) hours in a (2) consecutive calendar months measured in minutes shall receive service credit of (2) weeks.

**I. "Service Credit" shall mean:**

One (1) day Service Credit: One-thirtieth (1/30) of Dedicated Access Customer's Average Monthly Recurring charges.

One (1) week Service Credit: Seven-thirtieths (7/30) of Dedicated Access Customer's Average Monthly Recurring charges.

One (1) month Service Credit: thirty-thirtieths (30/30) of Dedicated Access Customer's Average Monthly Recurring charges.

**J. Obtaining Credit.** Customer's bill is credited automatically without any requests.



# Telecommunications & Installation Service Agreement

Client:

Provider:

USAC SPIN 143009866  
Business Automation Technologies, Inc.  
Dba Data Network Solutions

WHEREAS DNS owns and maintains its collocated facilities and interconnects with other carrier and internet networks and provides Internet, Circuits, Hardware and Voice telecommunications services and access connection services and Customer agrees to purchase said services.

NOW THEREFORE, in consideration of the mutual promises contained herein, both parties agree to honor this agreement under the following terms and conditions:

**Service Description:**

**Project # 1 Internet Services** as described in Service Order and the related published bid specifications and DNS proposal.

**At any time during the contract the customer can upgrade to any speed set forth in the attached signed Form 470 no.** and bid specifications. DNS shall provide a suitable connection to the Internet for Voice services if requested. **Expected Install date is 40 days after signing.**

**Price & Payment:**

Please refer to the attached service order for monthly recurring costs (MRC), estimated nonrecurring or one-time (NRC) costs including installation and equipment fees. Onetime charges do not include internal wiring and site power or space preparation. All one-time costs for hardware and services are estimates based upon standard conditions. Recurring monthly charges will be billed starting with the date of installation on an individual location or service item basis and run for 36 months (or as agreed to in writing) from that installation date. Partial months will be pro-rated. Upon request DNS shall invoice USAC for the reimbursed part of the monthly invoice and invoice the customer for the discounted part of the invoice.

A decorative graphic in the top left corner consists of a grid of thin, light blue lines that curve and fade out towards the right and bottom.

## Other Terms & Conditions

1. **Start of Work.** DNS shall start work upon receipt of a signed order.
2. "This contract is contingent upon District Board approval and the District receiving a favorable Funding Commitment Decision Letter (FCDL) from the Universal Service Administrative Company (USAC) for the requested amount. The school/district has the option of reducing the scope of the contract. If, for any reason, funding is denied, this agreement would be null and void.
3. "DNS certifies that we are not the subject of the FCC's Red Light Rule. Furthermore, we acknowledge that, should the FCC's Red Light Rule. Furthermore, we acknowledge that, should the company become the subject of the Red Light Rule, the contract would be null and void and the Company would not hold the District liable for any costs over their USAC discounted share."
4. We will abide by the conditions set forth in this bid including the District's right to reassign the contract as allowable by PA state law.
5. Customer shall provide routine power, space and access to premises.
6. DNS is not responsible for 3rd party delays including PBX, equipment vendor or facility availability or any other reason not under the control of DNS.
7. Any FCC universal service charges will be additional.
8. Telecommunications and hardware installation do not include internal wiring, moving furniture, site preparation or any such work that is not set forth in the service order or agreed to in writing otherwise.
9. Customer shall provide all standard information DNS requires to install the items in the service order including but not limited to prior carrier's customer service records, a signed letter of authority, and customer contact information.
10. DNS shall at all times perform services in a professional manner meeting industry standard.
11. The contract term will be rolled over on a month-to-month term at the same rates automatically unless customer provides at least one full months' notice that it is not renewing services at the end of the then current contract term.
12. Customer agrees to return all equipment belonging to DNS within 10 days after the termination of this contract.
13. DNS will not be responsible for the performance or delays of its third-party performance such as make ready of the customer facilities.
14. DNS is not liable for any business loss and/or insurance liabilities as a result of hardware, software, and network failure at DNS or any of its third-party interconnected network.
15. Service may be suspended upon 30 days' notice if DNS by does not receive total monthly payment within 30 days from date of invoice.
16. Any late payment that is 30 days past due may incur a 1.5% late fee charge.
17. Customer agrees to indemnify, defend and hold harmless DNS, its officers, directors, employees, agents, licensors, suppliers and any third-party providers to DNS services from and against all losses, damages and costs, including legal fees, resulting from any violation of this Agreement.
18. The customer sole compensation for any interruption or interference or performance degradation of any DNS service is the attached SLA.



An abstract graphic consisting of a grid of thin, light blue lines that form a perspective view of a rectangular plane, creating a sense of depth and movement.

## Other Terms & Conditions (cont.)

19. Customer agrees it is responsible for any maintenance of its own network against any malicious IP attacks and for the cost of any access by third parties to the customer's network making unauthorized calls. Customer agrees that DNS can shut off services to prevent such malicious attacks until such time as customer and DNS remediate the attack.

20. DNS will not be liable for the software contents stored in customer's equipment as well as content passed to and from between customer and the Internet.

21. This Agreement should be governed by and construed in accordance with the laws of the State of New Jersey. Both parties should endeavor to amicably settle any dispute or disagreement, which may arise between them. In case of an unresolved dispute, venue of litigation of such dispute shall be proper only in a New Jersey Court of competent jurisdiction.

22. **Default.** If the Customer defaults on its payments DNS shall be entitled to all legal costs including lawyer's fees, courts costs and any other costs to recover.

23. Early contract termination (ETL): Remaining monthly balances for any initial or renewal contract. 100% remaining months for cancellation in first 12 months, 50% remaining months for cancellation in the second year or subsequent years. ETL excludes USF charges and taxes.

24. Each of the parties to this Agreement represents that it has full legal authority to execute this Agreement and each is to be bound by the terms and conditions set forth herein. Each Customer agrees that the contract may be executed simultaneously by and between the parties via facsimile transmission, each of which should be deemed as original in nature and legally binding. Any alteration written or typed shall prevail only upon acknowledgment in written by both parties

25. **Notices.** All notices shall be in writing and all notices and payments shall be sent to the recipient at its respective address shown on the first page of this Service Order.

26. **Force Majeure.** Neither party shall be liable for any delay or failure to perform its obligations due to any cause beyond its reasonable control.

27. **Limitation of Actions.** No action, regardless of form or basis, arising out of transactions related to this Service Order or the Services performed or to be performed may be brought by either party more than two (2) years after the cause of action has accrued except that an action for nonpayment may be brought within two (2) years after the date of last payment.

28. **Waiver.** Waiver of either party's breach of this Service Order shall not constitute a waiver of any other breach. DNS may elect to continue performance notwithstanding such breach by Customer but such performance shall not constitute a waiver of such breach nor otherwise limit DNS's remedies.

29. **Maintenance.** Customer shall permit DNS access to it facilities as needed to perform periodic and emergency maintenance due to failures of the equipment and all components of the Telecommunications system during the term of this contract. DNS shall respond to all monitoring alerts and customer trouble reports submitted indicating a requirement to make repairs and immediately start troubleshooting. Upon failure isolation DNS shall contact all entities responsible for repairs. Any component belonging to DNS shall make every effort to restore the service to working condition within 24 hours.

30. **Pre-existing Conditions.** Any facility, conduit, or structure owned or leased by the customer that is found to be damaged and unusable or that fails during the course of this contract term shall be repaired at the sole expense of the customer.



## Other Terms & Conditions (cont.)

- 31. Customer agrees not to perform any work on the Telecommunications services or equipment without written consent from DNS. Customer agrees to keep the space in which DNS equipment is located in good condition free of any damaging substances. If any condition occurring that damages DNS equipment due to Customer breach of this paragraph DNS shall repair and bill Customer for repairs.
- 32. DNS shall assist and support customer in troubleshooting VoIP and Internet service issues at no cost, unless it is determined by DNS that the source of the trouble is within the customer's network. Customer agrees that DNS can charge for troubleshooting services at its normal rates if "No Trouble Found" in the DNS network.
- 33. The service order is an estimate of quantities and client may adjust such quantities upon written change order. DNS shall bill actual service time and materials and inform the customer of any reason for changes as soon as DNS is aware of the changes.
- 34. Any service order moves or changes or decreases or increases in the quantities of equipment or services after the installation is completed must be agreed to in writing by customer and DNS.
- 35. DNS shall monitor the customers Voice and Internet services and be available for support 24/7 and provide live technical responses.
- 36. **Insurance.** Customer shall procure and continuously maintain and pay for all risk insurance against loss of and damage to the DNS equipment for not less than its full replacement value.
- 37. In the event Customer receives information that the Telecommunications services are damaged, it shall notify DNS of said damage by phone at 800-649-6741.
- 38. **ENTIRE AGREEMENT.** This agreement shall be construed in accordance with the laws of the State of New York and Regulations of the Public Utilities Commission and DNS tariffs. This agreement constitutes the entire agreement between the parties and may only be modified by a written instrument executed by Customer and a Contract Officer of DNS. Any term or condition of an offer set forth on any Purchase Order or any other document created by Customer or DNS which is inconsistent with any term or condition of this Service Order shall be of no force or effect whatsoever. Neither Customer nor DNS shall be bound by any oral agreement or representation irrelative of by whom or when made.

*Client:*

*Provider:*

\_\_\_\_\_  
Company Name

\_\_\_\_\_  
Authorized Signature

Business Automation Technologies, Inc.  
Db a Data Network Solutions

\_\_\_\_\_  
Date

\_\_\_\_\_  
Title of Signee

\_\_\_\_\_  
Authorized Signature

\_\_\_\_\_  
Date





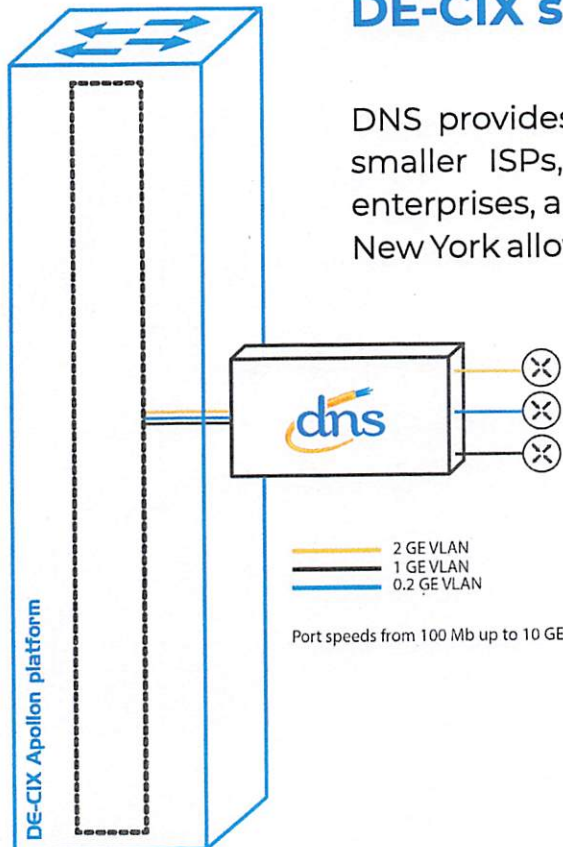

# Internet Peering Exchanges

## Data Network Solutions is a certified DE-CIX seller and connectivity provider.

DNS provides low cost, high quality DE-CIX peering access for smaller ISPs, content providers, cloud computing companies, enterprises, and other Internet focused businesses. Being based in New York allows DNS customers in the tri-state markets to improve their network quality and performance at a low cost by peering directly with major content providers, ISPs, and other network operators.



-  Get instant access to multiple networks
-  Control your own routing
-  Enhance the end-user Internet experience
-  Increase IP quality



# Internet Peering Exchanges

**DNS is a certified partner of NYIIX NY, one of the largest neutral internet exchange points on the US East Coast and the world.**

## What is an IX?

An IX (or IXP) is a physical Internet Exchange Point in data centers where ISPs and CDNs exchange traffic between their networks using network switches. It helps all ISPs collaborate and share infrastructure, making content delivery more efficient and fast by avoiding the need for data to travel to other cities or countries.

**NYIIX is available at the following New York Metro Locations:**

- 32 Avenue of Americas, NYC
- 60 Hudson, NYC
- 7 Teleport, NYC
- 85 10th Avenue, NYC
- 111 8th Avenue, NYC
- 165 Halsey St, Newark, NJ
- 275 Hartz Way, Secaucus, NJ

## NYIIX NY Members





# Our Other Leading Solutions



## Hosted PBX



Every business needs an affordable, easy-to-use communications solution that provides a competitive edge. DNS IP PBX Phone System offers unparalleled reliability and productivity gains in a cost-effective enterprise-class phone system designed to grow with your business.



## Wireless LTE 5G



80% of 911 calls are made from wireless devices. With wireless LTE 5G, you can experience lightning-fast data speeds, low latency, and reliable connections while supporting a higher number of devices at the same time. Enhance your school's safety with this simple solution.

NETSCOUT

## DDoS Protection



In today's digital world, where cyber threats are becoming increasingly sophisticated and frequent, DDoS protection is a must-have for any business that wants to maintain its online presence and protect its users. DDoS attacks can disrupt and disable websites and networks, causing significant financial losses, reputational damage, and legal consequences. With this protection, you can defend against these attacks and ensure the reliability of your network.

NETSCOUT

## Voice & Telecom



Voice and telecommunications services play a vital role in connecting organizations, enabling them to communicate and collaborate more efficiently and effectively. With the rise of cloud-based solutions, you can eliminate the need for expensive hardware and infrastructure, enabling you to save on maintenance and operational costs. From call centers to desktop faxing, we have the solutions to improve your operational efficiency in this interconnected world.





## Telecommunications Services for Voice Video and Internet

Item 1. Minute Bundles apply to Hosted Phone, Call Center License, PRI and SIP Trunk Phone Services			
Local and US 48 Minute Bundles Aggregated across all locations	Monthly Recurring Charge MRC 12 months minimum	Monthly Recurring Charge MRC 24 Months minimum	Monthly Recurring Charge MRC 36 months minimum
5,000	\$93.75	\$86.63	\$75
10,000	\$156.25	\$144.38	\$125
25,000	\$437.50	\$404.25	\$350
50,000	\$812.50	\$750.75	\$650
100,000	\$1,250.00	\$1,155.00	\$1,000
unlimited	\$2,500.00	\$2,310.00	\$2,000
	One time	One time	One time
One time Installation	\$1,000	no cost	no cost
<i>No specific hardware is required</i>			

Item 2. SIP Trunking Fees Provisioned over Broadband Connection			
Product	Monthly Recurring Charge MRC 12 months minimum	Monthly Recurring Charge MRC 24 Months minimum	Monthly Recurring Charge MRC 36 months minimum
SIP Trunk QTY 1-24	\$7.00	\$6.00	\$5.00
SIP Trunk QTY 25-50	\$6.00	\$5.00	\$4.00
SIP Trunk QTY 51-99	\$5.00	\$4.00	\$3.00
SIP Trunk QTY 100+	\$4.00	\$3.00	\$2.00
DID each	\$0.20	\$0.20	\$0.20
DID with E911 each*	\$1.00	\$0.90	\$0.75
	One time	One time	One time
One time Installation	\$500	no cost	no cost

Notes

\* E911 meets Kari Raybuam law

Voice, Unified Communications and Collaboration Solutions

Bid Number #ESCNI 23/24-10

BID OPENING DATE: October 6, 2023 11:00 am

**Mr. Anthony LaMarco**  
Business Administrator, Board Secretary/QPA





"Reliable Phone & Secure Internet Services"

**Item 3. PBX-PRI Phone Service over SIP Broadband Connection**

Number of PRI Channels	Monthly Recurring Charge MRC 12 months minimum	Monthly Recurring Charge MRC 24 Months minimum	Monthly Recurring Charge MRC 36 months minimum
1 PRI	\$66.13	\$57.50	\$50.00
2 PRI	\$99.19	\$86.25	\$75.00
3 PRI	\$132.25	\$115.00	\$100.00
4 PRI	\$165.32	\$143.75	\$125.00
	One time	One time	One time
One time Installation 1 to 2 PRI	\$ 500.00	no cost	no cost
One time Installation 2 to 4 PRI	\$ 1,000.00	no cost	no cost

**Item 4. VOIP FXS -Phone Service Over Broadband Connections  
 Replaces POTS lines or Mobile Remote Site Seat**

Number of Lines	Monthly Recurring Charge MRC 12 months minimum	Monthly Recurring Charge MRC 24 Months minimum	Monthly Recurring Charge MRC 36 months minimum
	Per line Charge	Per line Charge	Per line Charge
1 to 8	\$ 23.81	\$ 20.70	\$ 18.00
9 to 12	\$ 22.49	\$ 19.55	\$ 17.00
13 to 16	\$ 21.16	\$ 18.40	\$ 16.00
More than 16	\$ 19.84	\$ 17.25	\$ 15.00
	One time	One time	One time
One time Installation per Line	\$ 10.00	\$10.00	\$10.00

**Minutes Measured Rates**

Local	\$0.01	\$0.01	\$0.01
Regional	\$0.03	\$0.03	\$0.03
Intra-State Long Distance	\$0.03	\$0.03	\$0.03
Inter-State Long Distance	\$0.03	\$0.03	\$0.03

Requires gateway provided and managed at no cost by DNS. Used for Voice lines, PBX, faxes, postal machines, credit. alarms and other analog devices.

Voice, Unified Communications and Collaboration Solutions  
 Bid Number #ESCNI 23/24-10  
 BID OPENING DATE: October 6, 2023 11:00 am

**Mr. Anthony LaMarco**  
 Business Administrator, Board Secretary/QPA







\*Reliable Phone & Secure Internet Services\*

**Item 5. DNS Wireless POTS Line Replacement Solution**

Supports up to two analog lines includes 1GB of LTE data.

**Monthly Recurring**

Per Line	Data Overage Charges (1 GB included)
\$35 plus usage	\$9.00 per GB
Non-Recurring Charges	
Equipment Purchase	Setup Fee
\$425.00	\$25 per line

Lines do not include features and are not to be used for business voice services. Equipment should be connected to an internet connection and LTE connectivity is included in case of outage to support analog lines. Shipping not included.

**AT&T or Verizon Rates or US Cell**

**Item 6. LTE Failover**

MRC	\$20.00	
Rate Plans	MB Included	Usage Rate
49 MB	0 - 49	\$0.00
300 MB	50 - 300	\$3.00
500 MB	301 - 500	\$4.80
1 GB	501 - 1,024	\$11.55
2 GB	1,025 - 2,048	\$24.30
5 GB	2,049 - 5,120	\$54.90
10 GB	5,121 - 10,240	\$93.24

*\*Usage beyond 10 GB is billed in 10 GB increments at \$100.00*

*\*Shipping not included*

LTE Hardware Options			
Device	Equipment Rate	Setup Fee	Carrier Options
BEC MX 210NP	\$372.00	\$50.00	ATT & VZW
BEC MX 200Ae	\$564.53	\$50.00	ATT VZW USC
BEC MX-221P	\$412.50	\$50.00	ATT & VZW
BEC MX 1200/100u	\$1,015.61	\$75.00	ATT & VZW
CradlePoint E100	\$1,072.50	\$75.00	ATT VZW USC

25% restocking fee will be applied for any returned equipment  
BEC Portal Licensing is an additional \$7.50 Monthly Recurring Charge.

Voice, Unified Communications and Collaboration Solutions

Bid Number #ESCNI 23/24-10

BID OPENING DATE: October 6, 2023 11:00 am

**Mr. Anthony LaMarco**  
Business Administrator, Board Secretary/QPA





**Item 7. CONFERENCE CALLING No Reservation Unlimited Callers**

Product	MRC minimum 12 months	One Time NRC
Conference Calling Minute Cost for each user calling into bridge	\$0.05	
Conference enabled DID	\$5.00	\$10.00 per DID
<b>Number Concurrent callers</b>	<b>monthly rate</b>	
up to 10	Free.	
11 to 50	\$35.00	\$50 per account
51 to 100	\$65.00	\$50 per account
above 101	\$0.50 per concurrent caller	\$50 per account

Item 8. Call Center Options	Monthly Recurring Charge MRC 12 Months minimum	Monthly Recurring Charge MRC 24 Months minimum	Monthly Recurring Charge MRC 36 Months minimum
Call Center Seat License	\$50.03	\$33.35	\$29.00
Standard Agent	\$10.35	\$6.90	\$6.00
Supervisory Agent	\$25.88	\$17.25	\$15.00
Requires same equipment as hosted			
	One time	One time	One time
One time Installation per license	\$ 50.00	\$50.00	\$50.00

Voice, Unified Communications and Collaboration Solutions  
Bid Number #ESCNIJ 23/24-10  
BID OPENING DATE: October 6, 2023 11:00 am

**Mr. Anthony LaMarco**  
Business Administrator, Board Secretary/QPA





**Item 9. HOSTED PBX Phone Price List**

Product Seat License Fees	quantity	Monthly Recurring Charge MRC 12 months minimum	Monthly Recurring Charge MRC 24 Months minimum	Monthly Recurring Charge MRC 36 months minimum
Includes all features, one DID per seat, unlimited inbound calling minutes				
Hosted Seat License Fee Includes free intra district calling	1 to 100 licenses	\$10.58	\$9.20	\$8.00
	101 to 250 licenses	\$9.26	\$8.05	\$7.00
	251 to 500 licenses	\$7.94	\$6.90	\$6.00
	501 and above licenses	\$6.62	\$5.75	\$5.00
Voicemail Per seat license		\$2.00		\$ 2.00
<i>Unless the client already owns this equipment, they would need phones, switches, firewall, wiring, routers and UPS</i>				

**Item 10. Unified Communication and Collaboration Glom Client Price List**

Product Seat License Fees	quantity	Monthly Recurring Charge MRC 12 months minimum	Monthly Recurring Charge MRC 24 Months minimum	Monthly Recurring Charge MRC 36 months minimum
Glom Seat License Fee	1 to 100 licenses	\$3.97	\$3.45	\$3.00
	101 to 250 licenses	\$3.65	\$3.17	\$2.75
	251 to 500 licenses	\$3.32	\$2.88	\$2.50
	501 and above licenses	\$2.98	\$2.59	\$2.25
GloCom Android & IOS Per seat license		\$2.50	\$2.25	\$2.00

Voice, Unified Communications and Collaboration Solutions

Bid Number #ESCNI 23/24-10

BID OPENING DATE: October 6, 2023 11:00 am

**Mr. Anthony LaMarco**  
Business Administrator, Board Secretary/QPA





<b>Item 11. Applies to all Phone and Voice Services</b>			
Month to Month Phone Service Options	MRC	unit type	one time
<b>Hunt Group</b>	<b>\$5.00</b>	per month	<b>\$10.00</b>
<b>Auto Attendant</b>	<b>\$10.00</b>	per month	<b>\$10.00</b>
<b>Call Recording with 12 months per line storage</b>	<b>\$25.00</b>	per month	<b>\$25.00</b>
<b>E911 per site</b>	<b>\$5.00</b>	per month	<b>\$10.00</b>
<b>DID w/E911 per Dispatchable Location</b>	<b>\$1.00</b>	Per month	<b>\$5.00</b>
<b>Music On Hold</b>	<b>\$10.00</b>	per month	<b>\$10.00</b>
<b>Toll free DID Number</b>	<b>\$5.00</b>	per month	<b>\$10.00</b>
<b>Toll Usage rate US48</b>	<b>\$0.04</b>	per minute	<b>\$0.00</b>
<b>Directory Assistance 411</b>	<b>\$1.25</b>	per call	<b>\$0.00</b>
<b>Operator Assistance</b>	<b>\$1.25</b>	per call	<b>\$0.00</b>
<b>First Directory listing</b>	<b>\$0.00</b>	per month	<b>\$0.00</b>
<b>Additional Listings</b>	<b>\$4.00</b>	per month	<b>\$5.00</b>
<b>Non Published Listing</b>	<b>\$5.00</b>	per month	<b>\$10.00</b>
<b>Extra DID</b>	<b>\$0.20</b>	per month	<b>\$5.00</b>
<b>Account Changes</b>	<b>\$0.00</b>	per request	<b>\$25.00</b>
<b>DID Call forwarding</b>	<b>\$10.00</b>	month	<b>\$25.00</b>

Voice, Unified Communications and Collaboration Solutions  
Bid Number #ESCNIJ 23/24-10  
BID OPENING DATE: October 6, 2023 11:00 am

**Mr. Anthony LaMarco**  
Business Administrator, Board Secretary/QPA



# RESPONSE: ROCKY POINT UNION FREE DIST E-Rate Application 240008017

Tara Brady

Tue 2/13/2024 3:32 PM

To: Van Cott, Christopher A.

Re: Reves, Joseph

Cc: Warmbrand, Scott

1 attachments (1 MB)

Rocky Point UFSD 240008017 Internet DF Eline 2.13.2024.pdf;

**CAUTION:** This email originated from outside of our organization. Do not click links, open attachments or reply, unless you recognize the sender's email address and know the content is safe.

## ~Rocky Point UFSD Technology Department~

Good Afternoon Mr. VanCott,

Attached you'll find the BID response based on the request for:

**ROCKY POINT UNION FREE DIST | 470# 240008017**

This BID includes:

- Carrier Grade Internet & LIT Dark Fiber, Dedicated Symmetrical, Guaranteed Bandwidth
  - 1-3Gbps Internet with options, 1/10G Lit Dark Fiber, 100M E-line- 36 Months
  - Technical expertise from design to project implementation
  - Dedicated project management support on every Lightpath order that handles all communication with your team all the way through test and turn up completion
  - 24/7/365 Network Operations Center
  - 100% fiber network – owned | operated | maintained by Lightpath
- Services can be procured off the NYS OGS PS#68691
- Lightpath SPIN: 143000072

**NOTE: Service can be procured through Eastern Suffolk BOCES and Lightpath would bill ESB as account holder**

If you can confirm receipt of this email, I would greatly appreciate it.

We look forward to hearing from you!



**Tara Brady**  
 Regional Sales Manager | Gov/Edu  
 1111 Stewart Avenue  
 Bethpage, NY 11714  
 O: 516.803.6728

PRESIDENT'S CLUB  
MULTI-YEAR WINNER

**“THE BEST COMPLIMENT IS ALWAYS A REFERRAL”**

The information transmitted in this email and any of its attachments is intended only for the person or entity to which it is addressed and may contain information concerning Altice USA and/or its affiliates and subsidiaries that is proprietary,

2/14/24, 7:48 AM

Mall - Van Cott, Christopher A. - Outlook

privileged, confidential and/or subject to copyright. Any review, retransmission, dissemination or other use of, or taking of any action in reliance upon, this information by persons or entities other than the intended recipient(s) is prohibited and may be unlawful. If you received this in error, please contact the sender immediately and delete and destroy the communication and all of the attachments you have received and all copies thereof.

---



## Rocky Point UFSD

Prepared by:  
Tara Brady  
Regional Sales Manager | Gov/Ed  
516-803-6728

# Lightpath

SPIN: 143000072

Next Generation  
**Network**

Next Generation  
**Customer Service**

# About Lightpath

Lightpath is revolutionizing how customers connect to their digital destinations by combining our next-generation network with our next-generation customer service. Lightpath's advanced fiber-optic network offers a comprehensive portfolio of custom-engineered connectivity solutions with unparalleled performance, reliability, and security.

Our consultative customer service means we work with you to design, deliver, and support the solution for your unique needs, faster and more easily than ever before. For over 30 years, thousands of enterprises, governments, and educators have trusted Lightpath to power their organization's innovation. Learn how Lightpath can connect you to your digital destinations.

[www.Lightpathfiber.com](http://www.Lightpathfiber.com)





## Form 470 Application Number: 240008017

Service Address Location: 82 Rocky Point Road | 525 Route 25A – Rocky Point 11778

Term: 36 Months

Proposal Date: 02.13.2024

Proposal Expires: 04.31.2024

ACD or RFP Due Date: 02.15.2024

- Approximate Installation for fiber build and service turn up: 45-120 Days
- Billing shall Commence Upon installation
- Customer agrees to pay all applicable taxes, fees & surcharges, subject to change (estimated 3% total monthly recurring charges)
- Service offered of NYS OGS PS#68691
- Lightpath is not responsible for any errors within this document or any attached
- Pricing is budgetary and subject to change upon survey



**Rocky Point**  
UNION FREE SCHOOL DISTRICT

**Lightpath**

## Internet Pricing Proposal Options

Service Type: Internet Service	36 Month Term
1G Internet	\$865
2G Internet	\$1,350
3G Internet	\$1,825
/29 IP Allocation	\$34.95
/28 IP Allocation	\$49.95
/27 IP Allocation	\$64.95
Installation	\$0

Service Type: Internet w/DDoS, router port	36 Month Term
1G SecureNet	\$1,249
2G SecureNet	\$2,098
3G SecureNet	\$2,779
/29 IP Allocation	\$34.95
/28 IP Allocation	\$49.95
/27 IP Allocation	\$64.95
Installation	\$0

Service Type: Internet w/Router/Firewall & DDoS	36 Month Term
1G SecureNet+	\$1,535
2G SecureNet+	\$2,230
3G SecureNet +	\$3,490
/29 IP Allocation	\$34.95
/28 IP Allocation	\$49.95
/27 IP Allocation	\$64.95
Installation	\$0

- All costs are set in monthly recurring rates
- see estimated taxes on slide 3
- SecureNet + service offer Meraki firewall/router (licensing for term) and DDoS mitigation
- Pricing is based per circuit

# Fiber Strand & E-Line Pricing Proposal

Service Type: Multi strands Dark Fiber Lit with 1/10G	36 Month Term
Multi strand with 1G Optics	\$499
Multi strand with 10G Optic	\$499
Installation	\$0

Service Type: 100M E-Line	36 Month Term
100M Eline	\$530
Installation	\$0

- All costs are set in monthly recurring rates
- Both Fiber connection and E-Line must be procured together for rates shown above
- see estimated taxes on slide 3
- Costs shown without USAC discount

# Fiber Strand Proposed Design

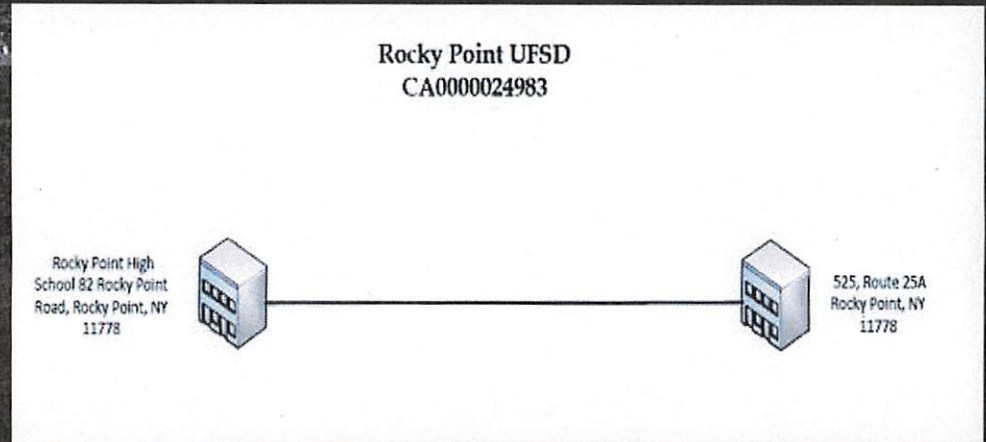

• All routes are proposed and subject to change based on availability at time of procurement.

# Internet Access

## Superior Service. Better Experience.

Enterprise-class Internet access over Lightpath's 100% fiber-optic network for faster, more reliable connectivity and a better experience.

- ▶ **Secure and reliable** to protect your critical data and provide superior network availability and resiliency. Services are delivered over our state-of-the-art, highly resilient packet network with multiple peering partners
- ▶ **Scalable bandwidth.** Options from 20 Mbps-100 Gbps. Scale as your organization grows. A keystroke change is all it takes to upgrade bandwidth
- ▶ **Flexible Configurations.** Choose from configuration options including high availability architecture and sharing IP over a wide area network
- ▶ **Design Options** Lightpath offers multiple configuration options, including IP sharing over a Wide Area Network (WAN)

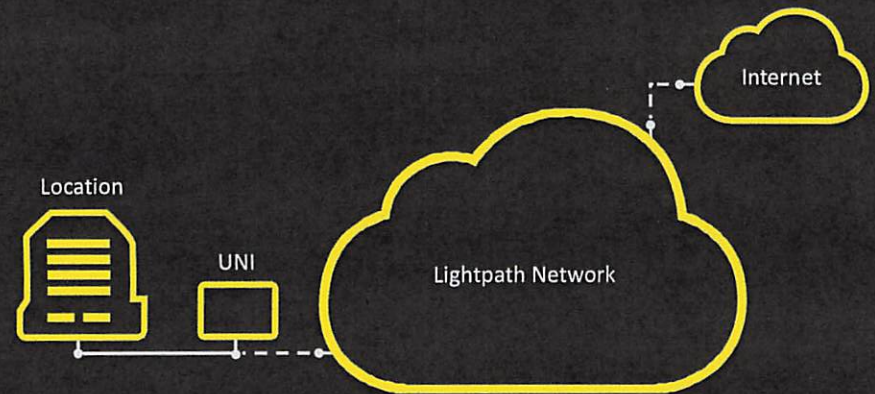

# E-Line, V-Line, and E-LAN

## E-Line

### Point-to-Point

Connect two business locations with a single dedicated point-to-point connection for quick, secure, data transfers. Get all the benefits of traditional private lines and the flexibility and scalability of Ethernet.

- ▶ Reduce costs. Simple flat rate pricing
- ▶ Simplified plug and play connectivity to premise equipment
- ▶ All customer traffic is protected and segmented on our network
- ▶ High performance network architecture protects critical data and provides superior availability and resiliency

## V-Line

### Hub-and-Spoke

Save money and rack space by sharing a single port across multiple network connections. The dedicated point-to-point service is ideal for businesses with one central hub plus remote locations. Lightpath's secure Ethernet virtual connections provide sub-50-millisecond resiliency for access.

- ▶ Flexible options to meet your specific business needs
- ▶ Each Ethernet Virtual Connection (EVC) is a secure, dedicated point-to-point connection

## E-LAN

### Any-to-Any

Share large amounts of data across three or more locations without having to replicate or resent data. Lightpath's E-LAN service provides a flexible, cost-effective solution for multipoint networks needing guaranteed bandwidth, plus the added security and reliability of Ethernet.

- ▶ Eliminate management of multiple Ethernet Virtual Connections and ports
- ▶ Eliminate switching of traffic through your corporate LAN
- ▶ Reduce management overhead with carrier switching

# Dark Fiber

Your own fiber, right where you need it. Layer 1 reliability and security, virtually unlimited bandwidth, combined with maximum control. Your Lightpath engineering team will work with you to determine the best options for where you need dark fiber.

## Reliability and Security

- ▶ Completely secure using your own dedicated strands of fiber
- ▶ Leverages unique rights-of-way providing added resilience to your infrastructure
- ▶ Predictable performance using your own optronics to light the network

## Customizable and Scalable

- ▶ Virtually limitless in its bandwidth and the services that it can support
- ▶ Cost doesn't vary with services you deploy on dark fiber
- ▶ Tailored to your connectivity requirements whether you need a single pair of fibers, or a more complex multi-site network

## Flexibility and Control

- ▶ Total control over your own private fiber, with your optronics on the endpoints
- ▶ Customers with in-house expertise can manage their own network
- ▶ Supports a large number of configurations, services and applications

# The Lightpath Difference



## Our Network

100% fiber, next generation optical and packet networks with unsurpassed flexibility, reliability, and security.

POPs are diverse from common data centers and typical locations, offering more geographic diversity.



## Our Solutions

Powerful and Reliable.

Optical Transport, Ethernet, Private Networks, Internet, Dark Fiber, Voice, Security Solutions, and Managed Services.

All custom-designed to meet your exact needs.



## Our Customer Service

From sale, to installation, to support, every point in a customer's journey with Lightpath is being examined and improved to create the best customer experience in the industry.





# Re-Thinking Customer Service

Lightpath is leaving no stone unturned as we revolutionize customer service within our industry.

## **Sales and Care**

We've doubled the size of our sales and care teams to provide more and better specialized service.

## **Dedicated Service**

Every customer is assigned a dedicated account executive and client services representative.

## **Commitment to Delivery**

We understand the importance of your connectivity and commit to delivering it on-time, and supporting it always.

## **Engineering Innovation**

In addition to our new networks, our engineering teams have been expanded, and are optimizing processes and systems across the company to better serve customers.

## **Local Customer Service Teams**

We care for our customers with local sales, operations, and support teams, who are experts in their markets.

## **24/7 Proactive Monitoring**

Of course, we also offer 24/7/365 proactive network monitoring and support.

Thank you!



Tara Brady  
Regional Sales Manager | Gov/Ed  
516-803-6728



Lightpath

+++

Lightpath

**SCHOOL YEAR 2024-2025**

**RESOLUTION (A)**

**JOINT MUNICIPAL COOPERATIVE BIDDING PROGRAM**

WHEREAS, various educational and municipal corporations located within the State of New York desire to bid jointly for generally needed services and standardized supply and equipment items; and

WHEREAS, the Rocky Point Union Free School District, an educational/municipal corporation (hereinafter the "Participant") is desirous of selectively participating with other educational and/or municipal corporations in the State of New York in joint bidding in the areas mentioned above pursuant to General Municipal Law § 119-o and Education Law Section 1950; and

WHEREAS, the Participant is a municipality within the meaning of General Municipal Law § 119-n and is eligible to participate in the Board of Cooperative Educational Services, First Supervisory District of Suffolk County (hereinafter Eastern Suffolk BOCES) Joint Municipal Cooperative Bidding Program (hereinafter the "Program") in the areas mentioned above; and

WHEREAS, the Participant acknowledges receipt of the Program description inclusive of Eastern Suffolk BOCES' standard bid packet and the general conditions relating to said Program; and

WHEREAS, with respect to all activities conducted by the Program, the Participant wishes to delegate to Eastern Suffolk BOCES the responsibility for drafting of bid specifications, advertising for bids, accepting and opening bids, evaluating bids, awarding via Eastern Suffolk BOCES Board approval, and reporting the results to the Participant.

BE IT RESOLVED that the Participant hereby appoints Eastern Suffolk BOCES to represent it and to act as the lead agent in all matters related to the Program as described above; and

BE IT FURTHER RESOLVED that the Participant hereby authorizes Eastern Suffolk BOCES to place all legal advertisements for any required cooperative bidding in Newsday, which is designated as the official newspaper for the Program; and

BE IT FURTHER RESOLVED that a Participant Meeting shall be held annually consisting of a representative from each Program Participant. Notice of the meeting shall be given to each representative at least five (5) days prior to such meeting; and

BE IT FURTHER RESOLVED that an Advisory Committee will be formed consisting of five to ten representatives of Program Participants for a term of three (3) years as authorized by General Municipal Law §119-o.2.j.

BE IT FURTHER RESOLVED that this Agreement with the Participant shall be for a term of one (1) year as authorized by General Municipal Law §119-o.2.j.

BE IT FURTHER RESOLVED that the Participant agrees to pay Eastern Suffolk BOCES an annual fee as determined annually by Eastern Suffolk BOCES to act as the lead agent for the Program.

Dated Approved:

\_\_\_\_\_

Rocky Point UFSD

Name of Educational or Municipal Corporation

\_\_\_\_\_  
Signature of Official

Jessica Ward

Printed Name of Official

President, Board of Education

Title

Christopher A. Van Cott

Contact Person - Name

Assistant Superintendent for Business

Title

\_\_\_\_\_  
E-Mail Address



# Smithtown Central School District

26 New York Avenue, Smithtown, New York 11787

**Daniel J. Helmes**  
Assistant Superintendent for Pupil Personnel Services  
(631) 382-2029

**Mark Secaur, Ed.D.**  
Superintendent of Schools

February 22, 2024

Kristen White  
Executive Director of Pupil Personnel Services  
Rocky Point Union Free School District  
90 Rocky Point-Yaphank Road  
Rocky Point, NY 11778

Dear Ms. White:

Enclosed please find two originals of the 2023-2024 DOR-DOL Parental Choice Contract for your **resident student(s) that have been parentally placed at a private or parochial school within the Smithtown Central School District**. We are requesting that you have the contracts forwarded to your Board of Education for their approval. Please return the partially executed contracts to us for our Board approval. Once approved, a fully executed copy will be sent to you for your files. Please note the addition of our **Parents' Bill of Rights for Data Privacy and Security**, which will need to be signed off as well.

We will proceed to bill your district for the special education services provided to your student for the 2023-2024 school year.

Please feel free to contact my office at (631) 382-2114 should you have any questions or concerns.

Very truly yours,

Daniel J. Helmes  
Assistant Superintendent for Pupil Personnel Services

DJH/ad  
Enclosures

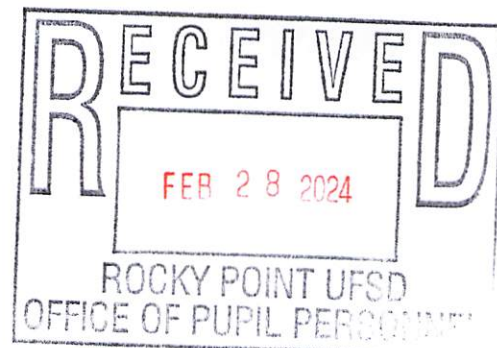

## AGREEMENT

This Agreement is entered into this 1st day of July, 2023 by and between ROCKY POINT UNION FREE SCHOOL DISTRICT (hereinafter the "DISTRICT OF RESIDENCE"), having its principal place of business for the purpose of this Agreement at 90 Rocky Point-Yaphank Road, Rocky Point, New York 11778, and SMITHTOWN CENTRAL SCHOOL DISTRICT (hereinafter the "DISTRICT OF LOCATION"), having its principal place of business for the purpose of this Agreement at 26 New York Avenue, Smithtown, New York, 11787.

### WITNESSETH

**WHEREAS**, DISTRICT OF LOCATION is required by Education Law Section 3602-c to provide special education services to parentally-placed students with disabilities, when such students attend private schools in DISTRICT OF LOCATION, but reside in DISTRICT OF RESIDENCE; and

**WHEREAS**, DISTRICT OF LOCATION is a public school district within the State of New York authorized to provide special education and related services to students with disabilities;

NOW, THEREFORE, the parties mutually agree as follows:

- A. **TERM:** The term of this Agreement shall be from July 1, 2023 through June 30, 2024 inclusive, unless terminated earlier as provided for in this Agreement.
  
- B. **SERVICES AND RESPONSIBILITIES:**
  1. DISTRICT OF LOCATION shall develop an individualized education service program (IESP) for those student(s) listed on the attached "Confidential Schedule A," incorporated by reference herein and made a part of this Agreement, and shall provide the services set forth in such IESP. If an IEP for any of the students covered by this Agreement was developed by DISTRICT OF RESIDENCE, and DISTRICT OF RESIDENCE obtains written parental consent, DISTRICT OF RESIDENCE shall forward the IEP to the Committee on Special Education of DISTRICT OF LOCATION. DISTRICT OF LOCATION shall provide the services recommended in such IEP, unless and until the IEP is amended by DISTRICT OF LOCATION's own Committee on Special Education.
    - a. A student(s) may be added or deleted from the attached Schedule "A" at any time. In such event, the payment amount owed by DISTRICT OF RESIDENCE shall be adjusted accordingly.
  
  2. The services provided by DISTRICT OF LOCATION to students under this Agreement shall be in accordance with each student's IESP, as it may be modified from time to time.

3. DISTRICT OF LOCATION shall perform all services under this Agreement in accordance with all applicable Federal, State and local laws, rules, and regulations, as well as established policy guidance from the New York State Education Department.
4. Both parties to this Agreement shall comply with the provisions of the New York State Safe Schools Against Violence in Education (SAVE) Act, including, but not limited to background checks and fingerprinting of all staff directly providing services to students. If requested, each District shall provide the other with the proof of clearance for employment from the New York State Education Department.
5. DISTRICT OF LOCATION represents its services under this Agreement shall be provided by qualified individuals of good character and in good professional standing. DISTRICT OF LOCATION represents that no individuals providing services under this Agreement are currently charged, nor in the past have been charged with any relevant criminal or professional misconduct or incompetence.
6. Upon execution of this Agreement, DISTRICT OF LOCATION shall provide copies of required licenses/certifications of all professionals providing services to student(s) under this Agreement. In the event that the required license/certification of any agent or employee of DISTRICT OF LOCATION providing services under this Agreement is revoked, terminated, suspended, or otherwise impaired, DISTRICT OF LOCATION shall immediately notify DISTRICT OF RESIDENCE in accordance with the requirements for all notices pursuant to this Agreement as set forth below.
7. DISTRICT OF LOCATION shall obtain whatever releases, prescriptions, or other legal documents that are necessary for DISTRICT OF LOCATION to provide services pursuant to this Agreement and to render full reports concerning the education and progress of the student(s).
8. DISTRICT OF LOCATION agrees to furnish to the State all reports, audits, etc. required to make determination as to eligibility under the provisions of the Regulations of the Commissioner of Education. Such material shall be furnished at such times as are required by the State. DISTRICT OF LOCATION agrees to provide the State access to all relevant records which the State requires to determine either DISTRICT OF LOCATION's or DISTRICT OF RESIDENCE's compliance with applicable Federal or State statutes or regulations with the effect of law, which regulate either the execution of this Agreement or the performance of obligations under this Agreement. DISTRICT OF LOCATION agrees to retain all materials and records relevant to the execution or performance of this Agreement in accordance with the provision or section 74.21 of volume 34 of the Code of Federal Regulations, but in no event less than six (6) years from the date of this Agreement.
9. DISTRICT OF LOCATION agrees to furnish written reports of each pupil's educational progress to DISTRICT OF RESIDENCE. DISTRICT OF LOCATION will render such reports to DISTRICT OF RESIDENCE at any time that such reports are made to the parents of the pupil(s) covered by the terms of this Agreement, and will

render such additional reports as may be required by DISTRICT OF RESIDENCE. At a minimum, all reports shall be furnished at the end of each semester, i.e. January 31st and June 30th. Any and all reports shall be furnished upon termination of this Agreement. DISTRICT OF LOCATION shall provide such additional information concerning the pupil's progress as may be required by DISTRICT OF RESIDENCE.

10. DISTRICT OF LOCATION shall maintain records, logs and/or reports in accordance with all applicable laws, regulations, requirements of the New York State Education Department or Health Department. DISTRICT OF RESIDENCE shall have the right to examine any or all records or accounts maintained and/or created by DISTRICT OF LOCATION in connection with this Agreement, and upon request shall be entitled to copies of same.
11. Upon reasonable prior written notice, DISTRICT OF LOCATION shall be subject to visitation by DISTRICT OF RESIDENCE and/or its designated representatives during the normal business hours of DISTRICT OF LOCATION.
12. DISTRICT OF LOCATION shall be subject to the visitation of the Commissioner of Education or his/her designated representative(s).
13. DISTRICT OF LOCATION shall maintain monthly attendance records which shall be submitted to DISTRICT OF RESIDENCE at the end of each month. If a child has been absent for a period of five (5) or more consecutive days, the attendance record shall indicate the reason for that absence.
14. DISTRICT OF RESIDENCE shall request and do its best to obtain written consent from parents or guardians of each student covered by this Agreement to the release of personally identifiable information concerning the child from DISTRICT OF RESIDENCE to DISTRICT OF LOCATION.
15. In the event that the parent or person in parental relation to a student(s) receiving services pursuant to this Agreement files a request for an impartial hearing or administrative complaint or initiates litigation in connection with such services, DISTRICT OF LOCATION shall promptly give written notice of same to DISTRICT OF RESIDENCE.
16. DISTRICT OF LOCATION agrees that all disciplinary measures for disabled students will be conducted in accordance with applicable Federal, State and local laws, rules and regulations.
17. DISTRICT OF RESIDENCE shall be responsible for providing all students listed in Schedule A of the Agreement with transportation to and from school.
18. DISTRICT OF LOCATION will provide transportation from the nonpublic school to a school in DISTRICT OF LOCATION and from DISTRICT OF LOCATION to the student's home if the special education services are provided after the nonpublic school day.



C. COMPENSATION:

1. DISTRICT OF LOCATION shall be entitled to recover from DISTRICT OF RESIDENCE 100% of the actual cost of services that may be charged for each student receiving services pursuant to this Agreement in accordance with the Education Law and the Regulations of the Commissioner of Education, hereinafter referred to as the "Actual Cost of Services."

"Actual Cost of Services" shall mean costs of services, costs of evaluation, and costs of committee on special education administration. However, the Actual Cost of Services shall not exceed the actual cost to DISTRICT OF LOCATION of providing such services, after deducting any costs paid with federal or state funds.

DISTRICT OF LOCATION may only recover the Actual Cost of Services directly from DISTRICT OF RESIDENCE if DISTRICT OF RESIDENCE has obtained parental written consent to the release of personally identifiable information concerning the child to DISTRICT OF LOCATION. If parental consent to release of such information is not obtained, DISTRICT OF LOCATION shall submit a claim for the costs of said services to the Commissioner of Education.

This Agreement recognizes that the authority for DISTRICT OF RESIDENCE and DISTRICT OF LOCATION to contract for the provision of special education services herein is derived from Education Law Section 3602-c, and related provisions of the Education Law and Regulations of the Commissioner of Education; and that it is these statutes and regulations that may define the maximum costs that may be charged hereunder.

DISTRICT OF LOCATION shall utilize its best efforts to accurately calculate the Actual Cost of Services, and such calculations will be consistent with the maximum costs that may be authorized by the Education Law and the Regulations of the Commissioner of Education to be charged.

2. Requests for payment by DISTRICT OF LOCATION shall be made by submission of a detailed written invoice to DISTRICT OF RESIDENCE on a monthly basis which references the time period for which payment is being requested, and a breakdown of the total amount due for the period specified.
3. DISTRICT OF RESIDENCE shall pay DISTRICT OF LOCATION within thirty (30) days of receipt of each invoice by DISTRICT OF RESIDENCE, except as set forth in paragraph C(1) of this Agreement.

D. INDEMNIFICATION:

1. To the fullest extent permitted by law, DISTRICT OF LOCATION agrees to defend, indemnify and hold harmless DISTRICT OF RESIDENCE, its officers, directors, agents, or employees against all claims, demands, actions, lawsuits, costs, damages and expenses, including attorneys' fees, judgments, fines and amounts, arising from any act, omission, error, recklessness or negligence of DISTRICT OF LOCATION, its

officers, directors, agents or employees in connection with the performance of services pursuant to this Agreement. The obligations pursuant to this provision shall survive the termination of this Agreement.

2. To the fullest extent permitted by law, DISTRICT OF RESIDENCE agrees to defend, indemnify and hold harmless DISTRICT OF LOCATION, its officers, directors, agents, or employees against all claims, demands, actions, lawsuits, costs, damages and expenses, including attorneys' fees, judgments, fines and amounts, arising from any act, omission, error, recklessness or negligence of DISTRICT OF RESIDENCE, its officers, directors, agents or employees in connection with the performance of services pursuant to this Agreement. The obligations pursuant to this provision shall survive the termination of this Agreement.

E. CONFIDENTIALITY:

1. DISTRICT OF LOCATION, its employees, and/or agents agree that all information obtained in connection with the services provided for in this Agreement is deemed confidential information. DISTRICT OF LOCATION, its employees, and/or agents shall not use, publish, discuss, disclose or communicate the contents of such information, directly or indirectly with third parties, except as provided for in this Agreement. DISTRICT OF LOCATION further agrees that any information received by DISTRICT OF LOCATION, its employees, and/or agents during the course of the services provided pursuant to this Agreement which concerns the personal, financial, or other affairs of DISTRICT OF RESIDENCE, its employees, agents, clients, and/or students will be treated by DISTRICT OF LOCATION, its employees, and/or agents in full confidence and will not be revealed to any other persons, firms, or organizations.
2. DISTRICT OF RESIDENCE, its employees, and/or agents agree that all information obtained in connection with the services provided for in this Agreement is deemed confidential information. DISTRICT OF RESIDENCE, its employees, and/or agents shall not use, publish, discuss, disclose or communicate the contents of such information, directly or indirectly with third parties, except as provided for in this Agreement. DISTRICT OF RESIDENCE further agrees that any information received by DISTRICT OF RESIDENCE, its employees, and/or agents during the course of the services provided pursuant to this Agreement which concerns the personal, financial, or other affairs of DISTRICT OF LOCATION, its employees, agents, clients, and/or students will be treated by DISTRICT OF RESIDENCE, its employees, and/or agents in full confidence and will not be revealed to any other persons, firms, or organizations.
3. In the event of a breach of the within confidentiality provision by either party, the breaching party shall immediately notify the non-breaching party and advise it as to the nature of the breach and the steps it has taken to minimize said breach. The breaching party shall indemnify and hold the non-breaching party harmless from any claims arising from its breach of the within confidentiality provision. The parties further agree that the terms and conditions set forth herein shall survive the expiration and/or termination of this Agreement.

4. Both parties to this Agreement understand that they may receive and/or come into contact with *protected health information* as defined by the Health Insurance Portability and Accountability Act of 1996 ("HIPAA") and information protected by the Family Educational Rights and Privacy Act ("FERPA"). The parties hereby acknowledge their respective responsibilities pursuant to HIPAA and, if necessary, shall execute a Business Associate Agreement in connection with such responsibilities.

F. REPRESENTATIONS:

1. All employees of DISTRICT OF LOCATION shall be deemed employees of DISTRICT OF LOCATION for all purposes and DISTRICT OF LOCATION alone shall be responsible for their work, personal conduct, direction, and compensation. DISTRICT OF LOCATION acknowledges that it will not hold itself, its officers, employees and/or agents out as employees of DISTRICT OF RESIDENCE. DISTRICT OF LOCATION shall, during the periods of its services hereunder, be engaged as an independent contractor. As such, DISTRICT OF LOCATION will be solely responsible for the payment of Federal and State income taxes applicable to this Agreement. DISTRICT OF RESIDENCE, if required by Federal or State requirements, will submit a Form 1099 and IT 2102.1 respectively at year-end to the Federal Government for all individuals having a gross income exceeding \$600, which thereupon will be reported for income tax purposes.
2. All employees of DISTRICT OF RESIDENCE shall be deemed employees of DISTRICT OF RESIDENCE for all purposes and DISTRICT OF RESIDENCE alone shall be responsible for their work, personal conduct, direction, and compensation. DISTRICT OF RESIDENCE acknowledges that it will not hold itself, its officers, employees and/or agents out as employees of DISTRICT OF LOCATION. DISTRICT OF RESIDENCE shall, during the periods of its services hereunder, be engaged as an independent contractor. As such, DISTRICT OF RESIDENCE will be solely responsible for the payment of Federal and State income taxes applicable to this Agreement. DISTRICT OF LOCATION, if required by Federal or State requirements, will submit a Form 1099 and IT 2102.1 respectively at year-end to the Federal Government for all individuals having a gross income exceeding \$600, which thereupon will be reported for income tax purposes.
3. Neither DISTRICT OF LOCATION nor any of its employees, agents, or assigns will be eligible for any employee benefits whatsoever relative to this Agreement including, but not limited to, Social Security, New York State Worker's Compensation, unemployment insurance, New York State Employee's Retirement System, health or dental insurance, or malpractice insurance, or the like.

G. INSURANCE:

1. Each party to this Agreement shall purchase from and maintain in a company or companies lawfully licensed to do business in the State of New York such insurance as will protect each party from claims set forth below for which the other may be

legally liable, whether such operations be by the other party or by anyone directly or indirectly employed by any of them, or by anyone for whose acts any of them may be liable.

2. Required Insurance:

- a. Commercial General Liability Insurance: \$1,000,000 per occurrence/ \$2,000,000 aggregate.
  - b. Automobile Liability: \$1,000,000 combined single limit for owned, hired and borrowed and non-owned motor vehicles.
  - c. Workers' Compensation and N.Y.S. Disability: Statutory Workers' Compensation, Employers' Liability and N.Y.S. Disability Benefits Insurance for all employees.
  - d. Professional Errors and Omissions Insurance: \$1,000,000 per occurrence/ \$2,000,000 aggregate for the professional acts of each party performed under the contract for the other party. If written on a "claims-made" basis, the retroactive date must pre-date the inception of the contract or agreement. Coverage shall remain in effect for two (2) years following the completion of work.
3. Each party shall provide the other with evidence of the above insurance requirements upon execution of the within Agreement. Each party further acknowledges that its failure to obtain or keep current the insurance coverage required by this Agreement shall constitute a material breach of contract and subjects the party to liability for damages including, but not limited to, direct, indirect, consequential, special and any other damages the other party sustains as a result of this breach.

H. MISCELLANEOUS

1. All notices which are required or permitted under this Agreement shall be in writing, and shall be deemed to have been given if delivered personally or sent by registered or certified mail, addressed as follows:

To DISTRICT OF RESIDENCE:  
Rocky Point Union Free School District  
90 Rocky Point-Yaphank Road  
Rocky Point, New York 11778

To DISTRICT OF LOCATION:  
Smithtown Central School District  
26 New York Avenue  
Smithtown, New York 11787

2. This Agreement, along with the attached "Schedule A," is the complete and exclusive statement of the Agreement between the parties, and supercedes all prior or contemporaneous, oral or written: agreements, proposals, understandings,

representations, conditions or covenants between the parties relating to the subject matter of the Agreement.

3. This Agreement has been arrived at mutually and is not to be construed against any party hereto as being the drafter hereof or causing the same to be drafted.
4. It is expressly understood that this Agreement shall not be assigned or transferred without prior written consent of the other party.
5. This Agreement may not be changed orally, but only by an agreement, in writing, signed by authorized representatives of both parties.
6. Should any provision of this Agreement, for any reason, be declared invalid and/or unenforceable, such decision shall not effect the validity of the remaining provisions of this Agreement. Such remaining provisions shall remain in full force and effect as if this Agreement had been executed with the invalid provision(s) eliminated.
7. This Agreement shall be governed by, and interpreted and enforced in accordance with, the laws of the State of New York without regard to conflicts or choice of law provisions that would defer to the substantive laws of another jurisdiction. Each of the parties hereto consents to the jurisdiction of any state court located within the County of Nassau, State of New York, or federal court in Federal District Court for the Eastern District of New York located in the County of Suffolk, State of New York, and irrevocably agrees that all actions or proceedings relating to this Agreement must be litigated in such courts, and each of the parties waives any objection which it may have based on improper venue or *forum non conveniens* to the conduct of and proceeding in any such court.
8. No course of dealing of any party hereto, no omission, failure or delay on the part of any party hereto in asserting or exercising any right hereunder, and no partial or single exercise of any right hereunder by any party hereto shall constitute or operate as a waiver of any such right or any other right hereunder. No waiver of any provision hereof shall be effective unless in writing and signed by or on behalf of the party to be charged therewith. No waiver of any provision hereof shall be deemed or construed as a continuing waiver, as a waiver in respect of any other or subsequent breach or default of such provision, or as a waiver of any other provision hereof unless expressly so stated in writing and signed by or on behalf of the party to be charged therewith.
9. Neither party will discriminate against any individual because of his/her age, race, creed, color, national origin, sexual orientation, military status, sex, reproductive health decisions, disability, predisposing genetic characteristics or marital status and will take affirmative action to ensure that each individual is afforded equal opportunities without discrimination because of his/her age, race, creed, color, national origin, sexual orientation, military status, sex, reproductive health decisions, disability, predisposing genetic characteristics or marital status.

I. AUTHORIZATION TO ENTER INTO AGREEMENT

1. The undersigned representative of DISTRICT OF LOCATION to this Agreement hereby represents and warrants that the undersigned is an officer, director, or agent of DISTRICT OF LOCATION with full legal rights, power and authority to enter into this Agreement on behalf of DISTRICT OF LOCATION and bind DISTRICT OF LOCATION with respect to the obligations enforceable against DISTRICT OF LOCATION in accordance with its terms.
  
2. The undersigned representative of DISTRICT OF RESIDENCE to this Agreement hereby represents and warrants that the undersigned is an officer, director, or agent of DISTRICT OF RESIDENCE with full legal rights, power and authority to enter into this Agreement on behalf of DISTRICT OF RESIDENCE and bind DISTRICT OF RESIDENCE with respect to the obligations enforceable against DISTRICT OF RESIDENCE in accordance with its terms.

**ROCKY POINT UNION FREE  
SCHOOL DISTRICT**

**SMITHTOWN CENTRAL  
SCHOOL DISTRICT**

By: \_\_\_\_\_

By: \_\_\_\_\_

Date: \_\_\_\_\_

Date: \_\_\_\_\_





# CENTER MORICHES SCHOOL DISTRICT

529 Main Street, Center Moriches, New York 11934 | 631 - 878 - 0052 | www.cmschools.org

## Central Administration

Dr. Ronald M. Mascra, *Superintendent of Schools*  
Ms. Keri Loughlin, *Assistant Superintendent of Business*  
Dr. Amy L. Meyer, *Assistant Superintendent for Curriculum*  
Dr. Ricardo Soto, *Assistant Superintendent for Student Services,*  
*Personnel & Instructional Technology*

## Board of Education

Mr. George Maxwell, *President*  
Mr. Marcus Babzien, *Vice President*  
Dr. Dawn DiPeri, *Trustee*  
Ms. Thomasina Harrell, *Trustee*  
Ms. Lauren Slianski, *Trustee*

Ms. Jeannine Barr, *District Clerk*  
Ms. Diane M. Smith, *Treasurer*

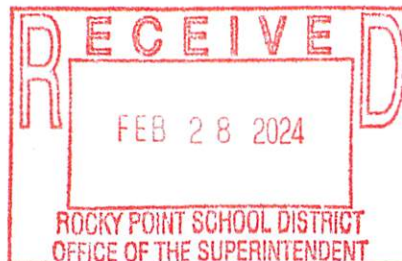

February 13, 2024

Dr. Scott O'Brien  
Superintendent of Schools  
Rocky Point UFSD  
90 Rocky Point- Yaphank Rd.  
Rocky Point, NY 11778

Dear Dr. O'Brien:

I am forwarding three (3) health services contracts for the 2023-2024 school year signed by the Center Moriches UFSD Board of Education president and the Superintendent of Schools. Please send (2) contracts signed as indicated and return them to my office. Please keep one duly executed contract for your district.

Included in this mailing is a list of students, a calculation of costs, and an invoice.

Thank you for your attention to this matter.

Sincerely,

Keri Loughlin  
Assistant Superintendent for Business

jm  
enc.





# CENTER MORICHES SCHOOL DISTRICT

529 Main Street, Center Moriches, New York 11934 | 631 - 878 - 0052 | www.cmschools.org

## Central Administration

Dr. Ronald M. Masera, *Superintendent of Schools*  
Ms. Keri Loughlin, *Assistant Superintendent of Business*  
Dr. Amy L. Meyer, *Assistant Superintendent for Curriculum*  
Dr. Ricardo Soto, *Assistant Superintendent for Student Services,  
Personnel & Instructional Technology*

## Board of Education

Mr. George Maxwell, *President*  
Mr. Marcus Babzien, *Vice President*  
Dr. Dawn DiPeri, *Trustee*  
Ms. Thomasina Harrell, *Trustee*  
Ms. Lauren Slionski, *Trustee*

Ms. Jeannine Barr, *District Clerk*  
Ms. Diane M. Smith, *Treasurer*

## CONTRACT FOR HEALTH AND WELFARE SERVICES

THIS AGREEMENT made in triplicate this First day of July 2023, by and between the Board of Education of the Rocky Point Union Free School District, 90 Rocky Point-Yaphank Rd., Rocky Point, New York, party of the first part, and the Board of Education, Center Moriches Union Free School District of Center Moriches, New York, party of the second part.

WITNESSETH, That whereas party of the first part has been duly empowered by the provisions of Section 912 of the Education Law to enter into a contract for the purpose of providing health and welfare services for children residing in said school district and attending nonpublic schools in Center Moriches School District, Center Moriches, New York, to begin on September 1, 2023, and to end June 30, 2024.

Now, Therefore, the said party of the first part hereby agrees to pay the party of the second part the sum of **\$4,067.36** for health and welfare services to be provided under Section 912 for 4 children residing in said school district of Rocky Point Union Free School District, New York, and attending nonpublic schools in said Center Moriches Union Free School District, of Center Moriches, New York.

And the party of the second part hereby agrees with the party of the first part as follows:

The services provided by *Center Moriches UFSD* shall be consistent with the services available to students attending public schools within the *Center Moriches UFSD* and may include, but are not limited to:

- a. all services performed by a physician, physician assistant, dentist, dental hygienist, registered professional nurse, nurse practitioner, school psychologist, school social worker, or school speech therapist,
- b. dental prophylaxis,
- c. vision and hearing screening examinations,
- d. the taking of medical histories and the administration of health screening tests,
- e. the maintenance of cumulative health records, and
- f. the administration of emergency care programs for ill or injured students.

*It is expressly understood and agreed between the parties that the services to be provided pursuant to this Agreement shall not include any teaching services.*

The party of the second part will also furnish the following equipment to be used in providing such services if requested by the authorities in charge of the nonpublic school:

Supplies and equipment for use by physician, school nurse-teacher, psychologist, dental hygienist, social worker, and speech correctionist (i.e. scales, vision and hearing testing devices, health record forms, first-aid supplies, and all other readily transportable equipment and supplies pertaining to delivery of services).

It is expressly agreed by and between the parties hereto that the services agreed to be supplied under this contract shall not include any teaching services.

It is mutually agreed that this contract shall not become valid and binding upon either party thereto until the same shall be approved by the (District) superintendent of schools.

In Witness Whereof, the parties have hereunto set their hands the day and year above written.

SENDER School District,  
Center Moriches School District

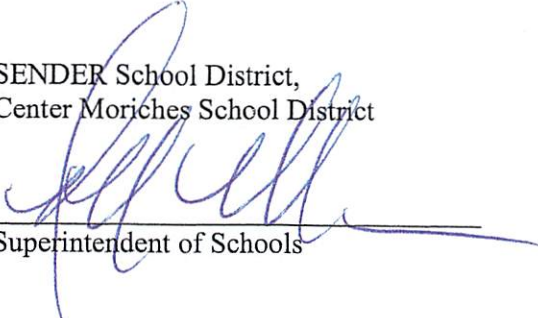

---

Superintendent of Schools

SENDER School District,  
Center Moriches School District

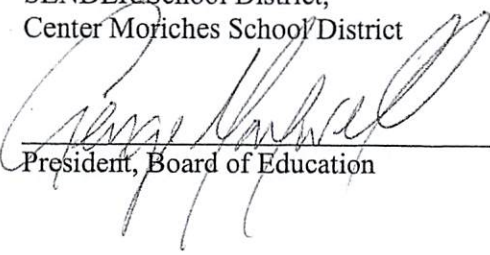

---



President, Board of Education

PROVIDER School District,  
Rocky Point Union Free School District

---

President, Board of Education

Center Moriches U.F.S.D. - Our Lady Queen of Apostles  
2023-2024 Health Services Listing

Grade	Student	District	Address	Town
		Rocky Point		
		Rocky Point		
		Rocky Point		
		Rocky Point		

(4)

**Center Moriches Union Free School District  
Center Moriches, NY 11934-2299**

**Health Services 2023-2024**

*(Revised)*

<b>Category</b>	<b><u>Costs 23-24</u></b>
Psychologists	\$346,273.97
Speech Therapists	\$232,557.00
Nurses	\$286,032.00
Pupil Services	\$119,754.56
Social Workers	\$80,181.00
Employee Benefits	\$597,369.83
Physicians	\$38,300.00
Equipment	\$4,500.00
Supplies and Services	\$14,500.00
<b>TOTAL</b>	<b>\$1,719,468.36</b>

<b>School Census</b>
----------------------

<b>District</b>	<b>Our Lady Queen of Apostle</b>	<b>L. Burket Christian School</b>	<b>Total</b>
Center Moriches	14	6	20
East Moriches	3	0	3
East Quogue	3	1	4
Eastport-South Manor	24	16	40
Longwood	8	13	21
Middle Country	0	3	3
Patchogue Medford	3	1	4
Riverhead	11	4	15
Rocky Point	4	0	4
Shoreham Wading River	2	0	2
South Country	12	4	16
Westhampton Beach	0	1	1
William Floyd	63	32	95
<b>Totals</b>	<b>147</b>	<b>81</b>	<b>228</b>

**Total District Enrollments**

Our Lady Queen of Apostles	147
L. Burket Christian School	81
Center Moriches Public Schools	<u>1453</u>
<b>Total</b>	<b>1681</b>

<b>Per Pupil Calculation: Total Cost/Total Enrollment:</b>
--

\$1,719,468.36 /	1681	\$1,022.88	per pupil
------------------	------	------------	-----------

**Center Moriches UFSD**529 Main Street  
Center Moriches, NY 11934**INVOICE****5173**

Invoice Date 02/29/2024

Customer No. 37

<b>Customer / Bill To:</b>
ROCKY POINT UFSD ATTN: SCHOOL BUSINESS OFFICIAL 90 ROCKY POINT YAPHANK RD. ROCKY POINT, NY 11778

<b>Remit To:</b>
Center Moriches UFSD 529 Main Street Center Moriches, NY 11934 ATTN: Business Office

Phone	Fax	E-Mail Address	Terms	Invoice Amount
631-878-0052	631-878-4326		DUE UPON RECEIPT	4,091.52

Items / Services	Cost Basis	Quantity	Unit Price	Amount
HEALTH SERVICES HEALTH SERVICES 2023/2024	ANN	4.00	1,022.880	4,091.52

**TOTAL: 4,091.52**

**ROCKY POINT UFSD**  
ATTN: SCHOOL BUSINESS OFFICIAL  
90 ROCKY POINT YAPHANK RD.  
ROCKY POINT, NY 11778

Invoice No. 5173

Invoice Date 02/29/2024

Customer No. 37

**Total Due: \$4,091.52**

Payment Terms: DUE UPON RECEIPT

Amount Enclosed:
------------------

**Mail Payments To:**

Center Moriches UFSD  
529 Main Street  
Center Moriches, NY 11934  
ATTN: Business Office





**ROCKY POINT UNION FREE SCHOOL DISTRICT**

90 Rocky Point-Yaphank Road  
Rocky Point, NY 11778

Telephone: (631) 744-1600

Fax: (631) 849-7557

**INSTRUCTIONAL SERVICES 2023-2024 CONTRACT**

**AGREEMENT**, made this 8<sup>th</sup> day of March 2024 by and between the BOARD OF EDUCATION of the ROCKY POINT UNION FREE SCHOOL DISTRICT (Rocky Point UFSD), Town of Brookhaven, 90 Rocky Point – Yaphank Road, Rocky Point, New York, 11778, (“Rocky Point”) and Mrs. Kristen Gunning, [REDACTED]

**WITNESSETH: WHEREAS**, Mrs. Gunning is a non-resident of the Rocky Point Union Free School District living at [REDACTED]; and

**WHEREAS**, Mrs. Kristen Gunning desires to maintain the enrollment of her daughter, [REDACTED], for the 2023-2024 School Year in the Rocky Point Union Free School District, specifically Rocky Point High School, as a non-district resident student as per Board of Education Policy #7130 Criteria for Admission under Special Circumstances;

**NOW, THEREFORE**, in consideration of the mutual promises herein set forth, it is agreed by and between the parties as follows:

1. [REDACTED], shall be admitted into the Rocky Point High School operated by Rocky Point UFSD on September 1, 2023 and shall receive instruction for a period ending June 26, 2024 on a non-tuition basis; said student shall be entitled to and shall receive like and equal instruction to that imparted to the children of like ages, grades and departments and shall be accorded all the rights and privileges enjoyed by resident students in attendance at said Rocky Point High School.
2. Transportation will not be provided
3. In consideration of the agreement set for herein, such services provided by Rocky Point, tuition will be waived for such instructional services during the 2023-2024 School Year.

**IN WITNESS WHEREOF**, the parties hereto have affixed hereunto their respective signatures.

**Rocky Point Union Free School District Town of Brookhaven**

By: \_\_\_\_\_  
Jessica Ward, Board of Education President

By: \_\_\_\_\_  
Mrs. Kristen Gunning

**STATE ENVIRONMENTAL QUALITY REVIEW ACT (SEQRA)/2024-25 CAPITAL  
PROGRAM**



**Rocky Point UFSD  
Personnel Schedule for Board of Education Approval - 3/18/2024**

**3/18/2024 Schedule-A Classified Staff**

Last	First	Position	Building	Rate	BOE Date	Amount	Effective Date	Description/Comments
Meyer	Melissa	School Teacher Aide	DW	N/A	3/18/2024	N/A	12/22/2023	Inactivation of Supplemental Student Assistance Stipend 2023-2024 school year.
Wooley	Cynthia	School Teacher Aide	DW	Annual	3/18/2024	1,000.00	1/2/2024	Supplemental Student Assistance Stipend 2023-2024 school year for half day (.5); Salary pro-rated.
Nunziata	Carrie-Ann	Food Service Worker	FJC	N/A	3/18/2024	N/A	3/6/2024	Unpaid leave of absence for medical reasons from 3/6/2024 thorough 4/2/2024.
Ericson	Toni	School Teacher Aide	JAE	N/A	3/18/2024	N/A	2/26/2024	Unpaid FMLA leave of absence beginning 2/26/2024 through 3/15/2024.
McCarville	Debra	Office Assistant	MS	N/A	3/18/2024	N/A	7/26/2024	Resignation for the purpose of retirement
Panzarella	Phillip	Part-Time Weekend Guard	DW	Hourly, Step 0	3/18/2024	25.00	3/23/2024	Part-time (2 days per week, 5 hours per day) ten-month contractual appointment. New position.
Allah	Rondu	Part-Time Weekend Guard	DW	Hourly, Step 0	3/18/2024	25.00	3/23/2024	Part-time (2 days per week, 5 hours per day) ten-month contractual appointment. New position.
Cornell	Diane	Food Service Worker	MS	N/A	3/18/2024	N/A	4/1/2024	Leave without absence without pay for medical reasons from 4/1/2024 through 6/26/2024.
Alabi	Malgorzata	School Lunch Monitor	JAE	N/A	3/18/2024	N/A	3/19/2024	Resignation to accept School Teacher Aide positon.
Alabi	Malgorzata	School Teacher Aide	DW	Annual, Step 11	3/18/2024	23,163.00	3/20/2024	Full-time, 10-month contractual appointment. Replaces R. Slawsky. Pro-rated.
Gebbia	Andrew	Custodial Worker I	FJC	N/A	3/18/2024	N/A	3/26/2024	Resignation for personal reasons

**Rocky Point UFSD**  
**Personnel Schedule for Board of Education Approval - 3/18/2024**

***3/18/2024 Schedule-B Certified Staff***

Last	First	Position	Bldg.	Rate	BOE Date	Amount	Effective Date	Description/Comments
Bennett-Rosman	Alexa	Teaching Assistant	HS	N/A	3/18/2024	N/A	3/27/2024	Resignation for personal reasons

**Rocky Point UFSD  
Personnel Schedule for Board of Education Approval - 3/18/2024**

***3/18/2024 Schedule-C Non-Teaching Substitutes***

Last	First	Position	Bldg.	Rate	BOE Date	Amount	Effective Date	Description/Comments
Allah	Rondu	Substitute Guard	DW	N/A	3/18/2024	N/A	3/22/2024	Inactivation for 2023-2024 school year

**Rocky Point UFSD  
Personnel Schedule for Board of Education Approval - 3/18/2024**

***3/18/2024 Schedule-D Teaching/Certified Substitutes***

Last	First	Position	Bldg.	Rate	BOE Date	Amount	Effective Date	Description/Comments
Borges	Brielle	Substitute Teacher	DW	Daily	3/18/2024	130.00 non preferred; 160.00 preferred	3/20/2024	2023-2024 school year

**Rocky Point UFSD  
Personnel Schedule for Board of Education Approval - 3/18/2024**

**3/18/2024 Schedule-E Co-Curricular Positions 2023/2024**

Last	First	Position	Bldg.	Rate	BOE Date	Amount	Effective Date	Description/Comments
Melella	Samantha	Volunteer-Boys Track and Field	DW	N/A	3/18/2024	N/A	3/11/2024	2023-2024 school year
Parker	David	MS Boys Track (Year 1)	DW	Annual	3/18/2024	4,016.00	3/25/2024	2023-2024 school year
Apicella	Ryan	Girls Varsity Basketball	DW	Daily	3/18/2024	Per Contract	2/16/2024	Extended season pay as a substitute for Katie Bittner. \$86.00 per practice and \$173.00 per game. Not to exceed three practices and one game.
Ciolino	Anthony	Volunteer-Track and Field	DW	N/A	3/18/2024	N/A	3/11/2024	2023-2024 school year
Calamonic	Meghan	LOTE Teacher	DW	Hourly	3/18/2024	50.00	7/1/2024	Translation of PreK-12 district documents for the 2023-2024 school year.

\*Up to two hours: \$58.00; in excess of two hours: \$86.00; Junior/Senior Prom: \$58.00 per hour 2023/2024 school year

**Rocky Point UFSD**  
**Personnel Schedule for Board of Education Approval - 3/18/2024**

***3/18/2024 Schedule-F Community Education***

Last	First	Position	Bldg.	Rate	BOE Date	Amount	Effective Date	Description/Comments