

9.12



Agenda Item Details

Meeting	Mar 17, 2021 - RSD Regular Board Meeting
Category	9. Discussion/Action
Subject	9.12 RSD and CSEA Chapter #329 Job Descriptions (New and Updated)
Access	Public
Type	Action
Fiscal Impact	Yes
Dollar Amount	231,230.00
Budgeted	Yes
Budget Source	General Fund and Measure L
Recommended Action	It is recommended the board take action and approve the RSD and CSEA Chapter #329 Job Descriptions (New and Updated)
Goals	<p>Goal 5-Recruit, hire, train, and retain exemplary employees who are caring, committed, collaborative, creative and critical thinkers.</p> <p>Goal 4-Prepare students to be college and career ready through technology and innovation that facilitates collaboration, creativity, critical thinking and communication.</p> <p>Goal 3-Create welcoming and safe environments where students attend and are connected to their school</p> <p>Goal 2-Engage parents and other District stakeholders in the development of meaningful partnerships to support student learning.</p> <p>Goal 1-Improved student achievement at every school and every grade in all content areas</p>

Public Content

Speaker: Carolyn Bernal

Rationale:

In November 2020, the RSD and CSEA Negotiating Teams met to negotiate some new job descriptions as well as some revisions to existing job descriptions.

The following are "new" job descriptions:

Technology/Bond Infrastructure & Learning Environment Support Technician, \$80,090 - \$93,181 (salary range includes base salary, statutory benefits, and health and welfare benefits), (to support the additional needs, work load and demands of the Technology Department; to be paid initially from Measure L)

Technology Information System Support Technician, \$68,015 - \$78,651 (salary range includes base salary, statutory benefits, health and welfare benefits), (to support the additional needs, work load and demands of the Technology Department)

District Programs Information Systems Support Clerk, cost neutral, (this newly revised job description replaces the Clerk Typist II position in the Educational Services Department vacated last year and that has remained

unfilled while the revised job description was negotiated; the newly revised job description accurately captures the work that was being performed and that will continue to need to be performed moving forward)

Plumber Irrigation Specialist, \$83,125 - \$97,232 (salary range includes base salary, statutory benefits, health and welfare benefits), (to support the additional needs, work load and demands related to district plumbing and irrigation needs of the Facilities Department)

The following are "existing" job descriptions that have been revised:

Education Technology/Network Support Specialist, no increased cost, (revisions were made to this existing job description to more accurately reflect the current work load and day to day work functions being performed)

Warehouse/Delivery Driver, no increased cost, (revisions were made to this existing job description to more accurately reflect the current work load and day to day work functions being performed)

All of the job descriptions listed (and attached) are pending CSEA ratification. The vote to ratify will take place Thursday, March 18th, 2021.

RSD and CSEA 329 new and revised jd.pdf (13,320 KB)

Administrative Content

Executive Content



California
School
Employees
Association

1505 Gardena Avenue
Glendale, CA 91204

(818) 244-1545

(800) 834-9959

FAX: (818) 244-8897

www.csea.com

Ben Valdepeña
Association President

Keith Pace
Executive Director

Member of the AFL-CIO

The nation's largest
independent classified
employee association



December 14, 2020

VIA Electronic

csearegion8carreon@aol.com

Henry Carreon
Chapter President #329 & Regional Representative #8
538 Gill Ave.
Port Hueneme, CA 93041-2849

RE: Memorandum of Understanding (MOU) – New & Revised Job Descriptions

Dear President Carreon:

I have received the Memorandum of Understanding (MOU) regarding the New and Revised Job Descriptions between the Rio Elementary School District and the California School Employees Association and its Rio Chapter #329 (CSEA).

It has been reviewed in accordance with Policy 610. I have found no apparent violation of law, CSEA's Constitution and Bylaws, or Policy.

Ratification for this MOU is required. Please provide your Labor Relations Representative Diane Wilkinson with the ratification date so that we may update our records.

Please ensure your chapter complies with the Ratification Meeting requirements as identified in your chapter constitution and Policy 610 Ratification Notice. Should your chapter choose to ratify prior to the "Shelter-in-Place" order and/or limitations on gatherings being lifted, please be sure to follow the October 14, 2020 temporary emergency waiver of Policy 610 (attached).

I would like to take this opportunity to acknowledge the time and effort spent by you and the Negotiating Committee in negotiations. Your involvement and dedications are truly appreciated.

Please feel free to contact my office if you have any questions or concerns.

Sincerely,

CALIFORNIA SCHOOL EMPLOYEES ASSOCIATION

Espie Medellin
Field Director

EM/vt
20 DW 329 MOU new and revised jd

Enclosure(s)

Cc: Don Snyder, Area I Director; Diane Wilkinson, Labor Relations Representative; Chapter #329 Contract File

MEMORANDUM OF UNDERSTANDING
BETWEEN
RIO SCHOOL DISTRICT
AND

CALIFORNIA SCHOOL EMPLOYEES ASSOCIATION AND ITS RIO CHAPTER #329

The California School Employees Association and its Rio Chapter #329 (CSEA) and Rio School District (the District) agree to the following new and revised job description as attached:

- 1) Technology Bond Infrastructure & Learning Environment Support Technician
- 2) Technology Information System Support Technician -New
- 3) District Programs Information Systems Support Clerk -New
- 4) Plumber Irrigation Specialist
- 5) Education Technology Network Support Specialist
- 6) Warehouse/Delivery Driver

For Rio School District:

Carolyn Bernal

For CSEA:

Henry Carren

Deane Wilkinson

Date: 11-19-2020

Date: 11/19/2020



JOB DESCRIPTION
TECHNOLOGY/BOND INFRASTRUCTURE & LEARNING ENVIRONMENT
SUPPORT TECHNICIAN
Range 38, (8) hours/12 Months

JOB SUMMARY:

Under the direction of the Director of Technology or other Technology Services administrator, assists in maintaining District standards for technology-assisted instruction and technology learning environment; provides ongoing assistance to district staff; performs a variety of tasks relative to assigned area of responsibility. The Technology Services Support Technician classification serves as on- and off-site technician and performs duties in the installation, support, and repair of computers, computer systems and software, local area networks, and other telecommunication devices.

REPRESENTATIVE DUTIES:

1. Assists in the repair and maintenance of computers, tablets and mobile devices, audio-visual equipment, software, and related peripherals devices;
2. Prepares software, hardware, and other devices needed for daily instructional use; adjusts software as needed to account for class and individual adjustments in curriculum based on site requests;
3. Troubleshoots, diagnoses, and repairs computer hardware and software, tablets and mobile devices and related software, and peripheral equipment.
4. Assists teachers in setting up and supporting on-site technology outside of the computer lab as needed;
5. Maintains computers for school use; imports, enters, and maintains user data and records for teachers;
6. Maintains a functional technology environment; performs preventive maintenance on computers and peripheral devices; performs regular cleaning of computer peripherals, mobile devices, and audio-visual equipment;
7. Serves as a technical resource to users and personnel, provides technical information and assistance by phone;
8. Works with Technology Services personnel to restore backed-up files and data in the event of a malfunction;
9. Participates in the imaging of computers, tablets, and mobile devices; loads specific software packages; joins and removes computers and devices from domains as needed;
10. Assists in maintaining the assigned site's website or web pages on the main District website;
11. Assists in presenting in-service training to parents, students, and staff, as directed;
12. Participates in maintaining an inventory of equipment and supplies;
13. Participates in maintaining a variety of records, including records of warranties and software licenses; contacts vendors for support for items under warranty;
14. Participates in maintaining a log of hardware and software problems; communicates with Technology Services for advanced troubleshooting help and submits support requests as needed; follows-up on reported problems as necessary;
15. Attends and participates in meetings, conferences, and seminars related to technology to maintain current knowledge of technological advances in the field.

OTHER RELATED DUTIES:

1. May create communication and materials to support staff working in the district technology environment;
2. Performs related duties as assigned.

KNOWLEDGE AND ABILITIES

Knowledge Of:

1. Operation, maintenance, and capabilities of personal computers, peripheral equipment, and mobile devices;
2. Methods, practices, terminology, and procedures and operations used in computer operations;
3. Commonly used software such as G Suite for Education and Microsoft Office programs and internet browsers;
4. Basic local area networking functions and concepts;
5. Basic technology troubleshooting techniques;
6. Modern office practices, procedures, and equipment.
7. Principles of computer maintenance and preventive maintenance
8. Basic record-keeping techniques;
9. Basic instructional methods and techniques.

Ability To:

1. Operate computer hardware, software, peripheral equipment, and mobile devices;
2. Diagnose and troubleshoot technology related problems;
3. Differentiate between hardware and software problems;
4. Gather, read, analyze, and interpret data;
5. Maintain confidentiality of privileged information obtained in the course of work;
6. Exercise good judgment;
7. Work independently with minimal direction;
8. Provide information and assistance to staff members in a helpful, courteous and timely manner;
9. Communicate effectively, both orally and in writing;
10. Understand and follow oral and written directions;
11. Establish and maintain effective working relationships;
12. Read, interpret and follow rules, regulations, policies, and procedures;
13. Learn instructional programs, curriculum, methods, and procedures;

EDUCATION AND EXPERIENCE:

1. ~~The No Child Left Behind Act of 2001 requires all individuals who provide instructional assistance to possess a high school diploma or equivalent along with one of the following:~~
2. A minimum of 48 semester units or 72 quarter units of college coursework.
3. An Associate or higher degree from an accredited college or university.
4. Pass an assessment that demonstrates knowledge of the ability to assist in teaching, reading, writing, and mathematics.
5. One year of computer operations experience including the troubleshooting and maintenance of computer hardware and software. An Associate Degree or equivalent from an accredited college or university in computer science or a closely related field may be substituted for the required experience.

LICENSES AND OTHER REQUIREMENTS:

1. Valid California drivers' license is desirable.

WORKING CONDITIONS:

1. Employees in this classification work primarily inside a computer repair workshop.

PHYSICAL ABILITIES:

1. Employees in this classification stand, walk, repetitively use fingers, use both hands simultaneously.

2. ~~Stoop/bend, Reach overhead, lift and carry up to 25 lbs. or over 25 lbs.~~ Lift and move objects weighing up to seventy-five (75) pounds **consistent with job family*
3. Have depth perception and color vision or the ability to distinguish shades.
4. Speak clearly and hear normal voice conversation.
5. Excessive stooping, bending, kneeling and reaching

***This funding for this position will be initially paid from the Measure L Bond.

**RIO SCHOOL DISTRICT IS AN EQUAL OPPORTUNITY/AFFIRMATIVE ACTION EMPLOYER
RIO PROVIDES A TOBACCO FREE ENVIRONMENT**

Adopted by the Rio School District Governing Board on April 23, 1997



EDUCATING LEARNERS FOR THE 21ST CENTURY

SCHOOL DISTRICT

* New

1800 Solar Drive, Oxnard, CA 93030 - Telephone: (805) 485-3111 - Fax Number (805) 604-7825 - www.rioschools.org

JOB DESCRIPTION

TECHNOLOGY INFORMATION SYSTEMS SUPPORT TECHNICIAN

RANGE 29 (8) hours/12 Months

JOB SUMMARY:

Under the direction of the Director of Technology or other Technology Services administrator, perform a variety of responsible and technical data control work in support of an assigned program or function within the Rio School District (RSD), including instructional programs, inventory data, student information system, library information system, personnel, business operations, or other specialized function; enter inventory, device insurance and student information and related program data from a variety of source documents; create a variety of lists and reports from input data; inspect files and records and update information as needed; perform a variety of research assignments and special projects as assigned; perform and assist in document workflows related to helpdesk information, shipping, and receiving; prepare and maintain logs, files and records; review and verify the accuracy and completeness of various documents; operate a computer workstation and a variety of other data processing equipment.

REPRESENTATIVE DUTIES:

1. Receive walk-in guests and telephone inquiries from a variety of individuals
2. Provide information about inventory, device insurances, programs, policies, and processes;
3. Resolve matters as appropriate, and direct inquiries and visitors to the proper person or office;
4. Perform technical data control and clerical duties related to assigned functions such as compiling information from a variety of sources and preparing complex reports as required. Communicate with other agencies or departments to provide or obtain a wide variety of information;
5. Enter inventory data, student information and related program data from a variety of source documents; update and modify information according to established procedures and program requirements;
6. Create a variety of lists and reports from input data; prepare and distribute letters and communiqués to staff and parents,
7. Prepare and maintain files; inspect files and records and update information as needed; verify paper records against computer records; assure proper enrollment and documentation of students in programs; digitize paper records
8. Receive and screen phone calls and visitors; provide information and direct inquiries and visitors to the proper person or office; provide technical information concerning policies and procedures of assigned program or office;
9. Perform a variety of research assignments and special projects as assigned; search files and contact individuals, departments, and agencies to gather required information; compile information and perform calculations as required;
10. Assist other office personnel with various office clerical and secretarial duties as assigned;

11. Prepare letters, memos, and forms, requesting, providing or verifying information; compose correspondence independently or from oral instructions; receive, screen and route mail;
12. Prepare, format, type, proofread and duplicate a variety of items including proposals, contracts, reports, agendas, minutes and student records;
13. Operate computers and peripheral equipment to enter, revise and update information; generate narrative, financial, and statistical records, reports, lists and summaries as needed; utilize various software applications as required by the position;
14. Prepare and maintain detailed and complex logs, files and records; maintain inventory on technology and device insurances; order and receive devices, supplies and materials as assigned; maintain the confidentiality of materials and information;
15. Assure timely distribution and receipt of a variety of records and reports; request or provide information as necessary; review and verify the accuracy and completeness of various documents and applications, assign proper codes to documents and enter into a computer system;
16. Operate a variety of office machines such as computers, printers, fax machines, copiers, and specialized equipment;
17. Attend meetings, workshops, and in-service training related to assigned duties, program and department; Perform related duties as assigned.

OTHER RELATED DUTIES:

1. May create communication and materials to support staff working in the district technology environment;
2. Performs related duties as assigned.

KNOWLEDGE AND ABILITIES

Knowledge Of:

1. Basic policies and procedures of the assigned program or department;
2. Operation of computers and related equipment;
3. Word processing, database, graphics, and other software applications used by the RSD Technology Services;
4. Methods and techniques of data entry;
5. Office practices, procedures, and equipment;
6. Common office clerical terminology, skills, and practices;
7. Basic financial and statistical accounting and record-keeping;
8. Record-keeping techniques, filing systems, and information management;
9. Correct English usage, grammar, spelling, punctuation, and vocabulary;
10. Operation of office machines, including a microcomputer and computer terminal;
11. Telephone techniques and etiquette; Interpersonal skills using tact, patience, and courtesy; and Oral and written communication skills.

Ability To:

1. Perform a variety of responsible and technical data control work in support of an assigned program or department;
2. Enter student information and related program data from a variety of source documents;
3. Create a variety of lists and reports from input data;
4. Inspect files and records and update information as needed;
5. Learn, apply, and explain basic laws, policies, and procedures related to assigned program or department;
6. Learn new software applications related to data entry;
7. Operate a computer terminal and a variety of other data processing equipment;
8. Read, interpret, apply and explain rules, regulations, policies, and procedures;
9. Learn the terminology of program or department;
10. Plan and organize work; Meet schedules and timelines;

11. Communicate effectively both orally and in writing;
12. Establish and maintain cooperative and effective working relationships with others;
13. Perform duties effectively with interruptions;
14. Maintain records and prepare reports;
15. Understand and follow oral and written directions;
16. Operate a variety of office equipment such as typewriter, computer terminal, word processing equipment, and copiers.

EDUCATION AND EXPERIENCE:

1. Any combination equivalent to: graduation from high school and two years of increasingly responsible experience involving the use of computer equipment and related software.

LICENSES AND OTHER REQUIREMENTS:

1. Must provide a certified certificate demonstrating the ability to type fifty-five (55) words per minute.
2. Some positions in this classification may be required to speak, read, and write a designated second language and/or possess a valid California driver's license.

WORKING CONDITIONS:

1. District Office environment.
2. Subject to many demands on time and constant interruptions.
3. Subject to sitting, bending or stooping, lifting and walking.
4. Subject to working in a school environment and exposure to sunlight and other outside conditions.
5. Subject to working at computer video workstation(s), operating computer keyboards, looking at computer video screens.

PHYSICAL ABILITIES:

1. Vision (which may be corrected) to read small print;
2. Hearing and speaking to communicate with others;
3. Perform work which is primarily sedentary;
4. Sitting or standing for extended periods of time;
5. Climbing stairs; Dexterity of hands and fingers to operate office equipment;
6. Bending, reaching overhead and above shoulders, and lifting and carrying objects weighing up to 30 pounds; and will be required to work at a computer screen terminal for prolonged periods.

**RIO SCHOOL DISTRICT IS AN EQUAL OPPORTUNITY/AFFIRMATIVE ACTION EMPLOYER
RIO PROVIDES A TOBACCO FREE ENVIRONMENT**

Adopted by the Rio School District Governing Board on April 23, 1997



JOB DESCRIPTION

DISTRICT PROGRAMS & INFORMATION SYSTEMS SUPPORT ^{Clerk} ~~TECHNICIAN~~
RANGE 33 (8) Hours

BASIC FUNCTION:

Under the direction of an assigned supervisor/administrator, coordinates and performs a wide variety of advanced and complex duties related to ongoing compliance and quality assurance of district programs, serves as support technician to schools and internal departments for data collection, interprets data using advanced statistical techniques, assists with modifying, documenting, and organizing information for analysis of state and federal program compliance and organizational standards. Provides administrative support with technical clerical functions, communications between departments and sites, in-service preparation, and materials, prepares and types a variety of items including forms and performs other related work as required.

REPRESENTATIVE DUTIES:

1. Assist with all aspects of quality management related to district programs, including assisting staff with maintaining state and federal program compliance and organizational standards.
2. Participates in inter department and school site discussions to assist with strategic planning and development of audit procedures to ensure documentation requirements are met, including any responses required post-audit.
3. Supports assigned supervisor/administrator with maintaining schedule of district program audits, state/federal and organizational reports to ensure all required documents are submitted.
4. Provides support with compiling data, ad hoc reports, district communications, and work methods related to organizational protocols/procedures.
5. Assists with designs or formats and implements new forms, bulletins, and manuals
6. Investigates and makes recommendations in connection with district program requirements and informational systems as preventive solutions for improvement.
7. Liaison for recommending department website updates with forms and informational resources related to district programs, methods, and procedures.
8. Assists with planning, organizing, and coordinating workshops, in-service training programs, and other related meetings.
9. Greets office visitors and answers telephones; responds to questions and provides information related to department policies and functions applicable to District rules, regulations, and policies, takes messages or refers callers to appropriate personnel.
10. May make minor decisions in accordance with district and department regulations, policies and guidelines and apply them to problem situations.
11. Provides information, training, and assistance to department personnel regarding new or revised procedures or resources such as computer programs and equipment
12. Takes and transcribes dictation of letters and memoranda, including material of a confidential nature, composes correspondence independently or from oral instruction.
13. Serves as a source of information regarding special projects, annual state/federal mandated reports, provide information where judgement, knowledge and interpretation are necessary, refer inquires to appropriate sources
14. Attend workshops, seminars, trainings, and other events as assigned

REPRESENTATIVE DUTIES continued:

15. Travel to other locations to provide assistance and training as needed.
16. Perform other related duties as assigned.

MINIMUM QUALIFICATIONS:

Knowledge of:

1. Excel, Microsoft Suite, PowerPoint, G Suite.
2. Principles of work simplification, office layout, form design, and records management.
3. Modern office methods and procedures.
4. Project management strategies.
5. Interpersonal skills and conflict resolution strategies.
6. Statistical analysis, report writing, presentation skills, and filing systems.
7. Quality management, strategic planning, and development of audit procedures.
8. Coordinating workshops, in-service training programs, and other related meetings.
9. Basic school district organization, operations, and objectives.
10. Concepts of culture and sensitivity to cultural diversity.
11. Correct English language usage; vocabulary, spelling, grammar, and punctuation.
12. Advanced commands and computer operating systems and standard applications.

Ability to:

1. Monitor a variety of data for completion and conformance with compliance procedures.
2. Provide training and support to schools and internal departments.
3. Analyze situations accurately and adopt an effective course of action.
4. Prepare comprehensive narratives and statistical reports, analyze data, and draw logical conclusions.
5. Plan and organize work to meet deadlines.
6. Work independently with little direction.
7. Read, interpret, and explain rules, regulations, and procedures.
8. Maintain a variety of reports, spreadsheets, and advanced filing systems.
9. Effectively build and maintain relationships with multiple departments to proactively identify quality management and take corrective action as needed.
10. Conduct research and analysis, write concise, logical, and grammatically correct letters and reports.
11. Work both independently and cooperatively, exercise judgement, creativity, and willingness to work with others on a team.
12. Maintain confidentiality.
13. Maintain consistent, punctual, and regular attendance.

Education and Experience:

Any combination of education, experience, and training which would indicate possession of the required knowledge, skills and abilities listed herein.

LICENSES AND OTHER REQUIREMENTS:

Valid California driver's license

WORKING CONDITIONS:

1. Office environment.
2. Subject to many demands on time and constant interruptions.
3. Subject to sitting, bending, or stooping, lifting, and walking.
4. Subject to working in school environment and exposure to sunlight and other outside conditions.
5. Subject to working at computer video workstation(s), operating computer keyboards, looking at computer video screens.

PHYSICAL ABILITIES:

Seeing to inspect documents and to read fine print; depth perception to file; hearing and speaking to communicate with others in a normal voice in person and on telephone; speak clearly to communicate with parents, staff and others; sitting or standing alternately for extended periods of time; climbing stairs; dexterity of hands and fingers to operate office equipment; write legibly; bending and stooping; reaching overhead and above shoulders, lifting, carrying, pushing, or pulling objects weighing up to twenty-five (25) pounds.



JOB DESCRIPTION

JOURNEYMAN PLUMBER/IRRIGATION SPECIALIST

RANGE 40 (8) HOURS/12 Months

JOB SUMMARY:

Under the direction of the Director of Maintenance of Operations & Transportation, the Plumber is responsible for installing, repairing and maintaining pipes, fixtures and other plumbing used for water distribution and wastewater disposal in school and department buildings. Maintains the flow and drainage of water, air, and other gases by assembling, installing, and repairing pipes, fittings, and plumbing fixtures district wide. Maintain and provide for safe condition and operation of all plumbing systems. Performs installation, maintenance and repair of irrigation systems, including operation of large equipment, ~~rodent and insect eradication, development of uniform turf and garden areas and surfaces, application of soil amendments and fertilizer.~~ Monitor and troubleshoot, maintain order, report and take all appropriate steps to maintain district grounds in uniform, relatively weed-free conditions with healthy plant conditions.

REPRESENTATIVE DUTIES:

1. Assemble, install, maintain, and pressure test all pipes, fittings, and fixtures of heating, water, drainage, sprinkler, and gas systems according to specifications and plumbing codes.
2. Determine sources of plumbing malfunctions and complete repairs as indicated or according to work orders.
3. Locate and mark positions for connections and fixtures.
4. Install and repair pipes, fittings, valves fixtures, and plumbing system equipment, including sinks, commodes, water heaters, water softeners, etc.; install supports and hangers for pipe, fixtures and equipment.
5. Read blueprints, drawings, and specifications to determine the layout of plumbing systems, water supply networks and waste and drainage systems.
6. Plan install and service plumbing systems, fixtures, piping equipment and controls; test pipe systems and fixtures for leaks.
7. Repair dishwashers and kitchen equipment that gas or water consumption.
8. Receive and complete work orders.
9. Inspect jobs upon completion and ensure areas are clean.
10. Work with site principals and department supervisors to complete projects.
11. Respond to emergency calls as needed.
12. Perform preventative maintenance on tools and equipment, ensure that equipment is in safe operating condition.
13. Operate tools and equipment according to established safety procedures.
14. Maintain all building codes, installation requirements and relevant legislation.
15. Correct unsafe conditions in the work area and report any conditions that are not correctable to the supervisor immediately.
16. Performs related duties as directed ** added*

IRRIGATION DUTIES:

1. Schedules routine testing, orders repair parts and repairs all district's irrigation systems.
2. Monitors and reports on the condition of, and repairs damage to, garden and field areas and irrigation systems.

IRRIGATION DUTIES CONTINUED:

3. Maintains communications with outside monitoring agencies and operates irrigation systems to ensure water levels, times, and frequencies are properly maintained.
4. Plans and implements programs designed for the beautification of all district landscape areas, plants, cultivates, waters and sprays ornamental plants, shrubs, hedges, trees, flowers and lawns.
5. ~~Trims hedges and shrubs, prepares and treats soil for planting, spades and fertilizes flower beds and sets out plants.~~
6. ~~Uses pesticides to keep assigned areas free from pests and plant diseases.~~
7. ~~Rakes leaves, hoes weeds and performs general grounds maintenance work. Sweeps and picks up papers, trash and refuses.~~
8. Properly operates, maintains and repairs all tools, equipment, vehicles and irrigation systems in use.
9. ~~Maintains athletic fields and playground equipment.~~
10. May be assigned custodial duties either seasonally or to incidental gardening activities.
11. Operate large equipment including, but not limited to back-hoes, trenches, seeders, top-dressers, etc.
12. Examines facilities on a regular basis for the purpose of preventative maintenance and safety.

KNOWLEDGE AND ABILITIES

Knowledge Of:

1. Knowledge of local and state regulatory plumbing codes and requirements.
2. Knowledge of repair and maintaining pipes, fixtures, installations and plumbing.
3. Knowledge of sprinkler systems.
4. Safe working methods and procedures.
5. Basic computer skills, such as accessing the internet and e-mails.
6. Knowledge of plumbing repairs, maintenance, and installation techniques.
7. Extensive knowledge in the use of equipment, materials, methods, plantings, practices and procedures associated with landscaping and irrigation.
8. Knowledge of and ability to safely use gardening tools, materials, and equipment with skill and efficiency.
9. Knowledge of tools, equipment techniques, skills, materials, and methods of irrigation system design, installation and maintenance.
10. ~~Knowledge of mixing and the application of appropriate planting mediums.~~

ABILITY TO:

1. Learn quickly and adapt to a variety of technology, tools, instructions, and task methods.
2. Meet deadlines in terms of work assignment schedules.
3. Interact daily in person with other members of the department and school district staff and possess comfortable interpersonal skills and cooperative attitudes.
4. Maintain consistent attendance due to the urgent nature of duties.
5. Ability to understand and follow oral and written directions.
6. Ability to make independent decisions to respond to numerous requests, deadlines, and to prioritize assignments.
7. Ability to read and interpret blueprints, diagrams, schematics, and written reference material.
8. Ability to perform mathematical calculations.
9. Ability to diagnose and resolve power tools.
10. Ability to use hand and power tools.
11. Ability to operate equipment such as trenching machines and digging tools and other related grounds/landscape equipment.
12. Ability to learn and utilize various types of irrigation control systems * added

EDUCATION AND EXPERIENCE:

1. (2) Two years of experience as a skilled worker in the plumbing trade
2. Equivalent to the completion of the twelfth grade, supplemented by training in plumbing maintenance trades.
3. Irrigation systems experience desirable * added

LICENSES AND OTHER REQUIREMENTS:

1. Possession of valid California Motor Vehicle Operator's License.
2. Licensed Journeyman Plumber in the State of California.
3. Valid Backflow Certification desirable
4. ~~Must be able to acquire and maintain the appropriate certification required to safely and lawfully apply insecticide, herbicide, and other pesticides on school district property.~~

PHYSICAL REQUIREMENTS:

1. Working around and with machinery having moving parts.
2. Working at heights.
3. Power saws and flying debris or nails.
4. Chemical fumes.
5. Electrical power supply and high voltage.
6. Excessive walking, standing, climbing.
7. Excessive stooping, bending, kneeling and reaching.
8. ~~Moderate to heavy lifting and carrying.~~
9. Lift and move objects weighing up to seventy-five (75) pounds. *→ added*

WORKING CONDITIONS:

1. Frequent exposure to hot or cold temperatures for one hour plus.
2. Around moving objects, equipment and vehicles.
3. Exposure to chemicals (herbicides and fertilizers).
4. Exposure to noise, dust, and fume levels will vary depending on the equipment and projects.
5. Frequent district wide travel.
6. Subject to working in adverse weather conditions, fumes from chemicals, machine vibration, noise, heat *→ added*.



EDUCATION TECHNOLOGY/NETWORK SUPPORT SPECIALIST

(12) Months /RANGE 40

JOB SUMMARY:

Under the direction of the Director of Technology, provide technical support to teachers, administrators and classified staff in educational technology practices. Assist with training, guidance and support to beginning users, including advanced techniques to maximize learning engagement through the use of appropriate technology tools.

REPRESENTATIVE DUTIES:

- added x* 1. Assists in research and testing related to acquiring new hardware and software; provide support for administrators, teachers, and classified staff in adopting and using new technologies.
- added x* 2. Provide guidance, training and support with digital resources to enhance digital literacy skills to support teaching and learning.
- added* 3. Assists employees with training and support in user awareness around data sensitivity and security.
4. Assists with the implementation of the District Technology Plan and works closely with staff and community to accomplish the implementation of goals.
5. Assists with the development and implementation of the District-wide master plan for training of staff; assist with training in all aspects of district hardware and software products.
- added* 6. Assists with the technology related coordination and development duties of district's pedagogical planning and support including the work with site staff when new technologies or organizational structures are developed and implemented.
7. Installs, maintains, and configures LAN's, WAN's microcomputers, data and telecommunications.
8. Responds to user requests for assistance and malfunction correction.
9. Establishes and maintains electronic communications and data transfer between district sites.
10. Reconfigures and upgrades hardware and software as appropriate, performs hardware assembly, installation, configuration, maintenance and repair of microcomputers, LAN's and WAN's.
11. Performs the more complex and technical systems designed to maintain and enhance assigned systems, assists with the overall design features and requirements of educational technology systems.
12. Serves as a technical resource to users; providing technical information and assistance by phone or on site.
13. Maintains a variety of records related to installation, configurations, inventory, cabling, equipment and maintenance and repair history, time worked and services provided.
14. Assists with analyzing software and hardware problems, needs and develops recommendations for possible solutions.
15. Disseminates current literature and research which contributes to the improvement of instruction using technology.

KNOWLEDGE AND ABILITIES:

Knowledge of:

- 1 Principles, basic operation, and installation of LAN's, WAN's, telecommunication systems and related software.
- 2 Configuration documentation techniques
- 3 Advanced commands and computer operating systems and standard applications and languages utilized by the District including but not limited to Novell, Token Ring, Windows, AppleTalk.
- 4 Internet navigation tools and e-mail systems.
- 5 Software maintenance, network performance tuning and system diagnostic software.
- 6 Systems design for voice video and data technologies.
- 7 Network and software maintenance and preventative maintenance techniques.
- 8 Network performance tuning and development of system support software.
- 9 Advanced DOS commands.
- 10 Various software applications including word processing, spreadsheets, database management, telecommunications and graphics programs.

ABILITY TO:

- 1 Follow the District's technology plan.
- 2 Install, maintain and configure LAN's, WAN's, microcomputers, telecommunications and software applications systems.
- 3 Assist in the analysis of computer systems and requirement.
- 4 Perform research, analysis and evaluation of state-of-the-art hardware and software network technologies
- 5 Develop, prepare and present technical briefings and specifications related to the implementation of LAN's within the District.
- 6 Assist with conducting training in all aspects of District hardware and software products.
- 7 Evaluate, test and adapt new information processing and communication techniques.
- 8 Setup and maintain microcomputer software and related systems and their applications.

EDUCATION AND EXPERIENCE:

- 1 Two years of college study in computer science, management information systems or a closely related field, supplemented by training and/or coursework
- 2 A combination of education and experience that demonstrates desired knowledge and ability.

LICENSES AND OTHER REQUIREMENTS:

- 1 A valid State of California Class driver's license is required.
- 2 CPR and Red Cross First Aid Certificates are desirable.

WORKING CONDITIONS:

- 1 Subject to sitting, bending, stooping, lifting and walking.
- 2 Subject to working at computer video work station, operating computer keyboards looking at computer video screen.
- 3 Manipulation of fingers for typewriters, calculators and computer keyboards.
- 4 Subject to working in school environments and exposure to sunlight and other outside conditions.

PHYSICAL ABILITIES:

1. See to read fine print.
2. Speak in a normal voice to be able to be heard in person or by telephone.
3. Understand normal conversations and oral instructions.
4. Write legibly.
5. Use hands and fingers to operate typewriter, computer keyboard, adding machine/ calculator.
6. Sit or stand alternately for an eight hour day with designed breaks.
7. Bend or stoop to perform tasks such as filing and storage of materials.
8. Lifting up to thirty pounds without assistance.

Rio School District is an Equal Opportunity/Affirmative Action Employer and Provides a Tobacco Free Environment



JOB DESCRIPTION

WAREHOUSE/DELIVERY DRIVER

Ware house ~~area~~

JOB SUMMARY:

Under the direction of the Director of Child Nutrition and Wellness, perform a variety of warehouse functions including the receipt, inspection, verification, storage, processing and distribution of a variety of supplies, materials and equipment. assists in inventory control *added* drive a vehicle to various District locations to deliver goods;

REPRESENTATIVE DUTIES:

1. Perform a variety of warehouse functions including the receipt, inspection, verification, storage, processing and distribution of assigned goods such as supplies, materials, documents, books, equipment, department and/or district mail, money deposits packages and food items; assure designated goods are delivered in a timely manner. *added*
2. Receive, unload and inspect shipments for damage and conformity to purchase order specifications and packing slips; review shipments for accuracy including quality and quantity; identify and resolve shortages, damage goods or other problems and discrepancies.
3. Shelf, stock and store items in appropriate sections of the warehouse; load and prepare various items for delivery; receive, fill and process requisition; pull, pack, sort and ship items to various locations according to established procedures; arrange outgoing deliveries and routes with site personnel.
4. Drive a vehicle to school sites, offices, cafeterias, mailrooms and other District locations to pick up and deliver a variety of goods; load trucks with appropriate supplies and equipment; assure deliveries comply with quantity and product specifications; obtain signatures; pick up and deliver mail as needed.
5. Place food items in racks, coolers or freezers as assigned; assure proper temperature of food items; rotate perishable and nonperishable inventory as needed; clean and sweep warehouse, freezers, refrigerators and storage areas as required.
6. Monitors temperatures of freezers and refrigerators on a daily basis. Maintains current temperature logs. *← added # 6*
7. Communicate with District personnel and various outside agencies to exchange information and resolve issues or concerns.
8. Operates a variety of warehouse equipment such as forklifts, pallet jacks, delivery vehicles and dollies; utilize standard office equipment including a copier, fax machine, computer and assignment software (ex. Escape) *added*
9. Prepare outgoing shipments for delivery; assure items and supplies are properly loaded and secured for transport; place and store items in appropriate storage areas at schools and other District sites.
10. Maintain and organize warehouse inventory; assist maintaining appropriate levels of regular store stock items as assigned; participate in conducting and maintaining regular and periodic inventories.
11. Inspect delivery vehicle to assure proper operating condition; perform routine maintenance as needed, check and replenish fuel, oil, water and tire inflation levels as needed.
12. Restock, returned items as needed, repackage various products into smaller issuing units as needed.

13. Monitors warehouse inventory for the purpose of ensuring the accurate allocation of expenses and tracking of assets.
14. Makes recommendations as needed to improve procedures for the purpose of meeting the district's goals and objectives.
15. Responds to emergency situations for the purpose of addressing immediate safety concerns.
16. Maintain warehouse and other assigned areas in a clean, orderly and safe condition.
17. Perform other duties as assigned.

KNOWLEDGE AND ABILITIES

Knowledge Of:

1. Methods, practices and terminology used in warehouse operations
2. Use and terminology of requisitions, purchase orders, packing slips and other warehouse documents.
3. Practices, procedures, terminology and techniques involved with receipt, issuing and distribution of supplies and materials.
4. Proper loading and unloading of trucks.
5. Traffic laws, defensive driving techniques and rules of the road.
6. Operation of forklift, pallet jack and other warehouse equipment.
7. Proper methods of storing equipment, materials and supplies.
8. Oral and written communication skills.
9. Interpersonal skills using tact, patience and courtesy.
10. Operation of standard office equipment including a computer and assigned software.
11. Proper lifting techniques.
12. Sanitation, health and safety regulations. *added*
13. Basic record-keeping techniques.
14. Basic mathematics.

Ability To:

1. Perform a variety of warehouse functions including the receipt, inspection verification, storage, processing and distribution of a variety of supplies, material and equipment.
2. Drive a vehicle to various district locations to deliver goods
3. Shelve, store and prepare warehouse items for delivery.
4. Load and unload shipments and equipment.
5. Operate a forklift, pallet jack and other warehouse equipment.
6. Utilize space efficiently and effectively.
7. Maintain various records related to work performed.
8. Make independent decisions and judgments in the field without direct supervision when pertaining to the delivery schedule, rotating stock, and deciding on the appropriate time to take scheduled breaks and fuel stops
9. Maintain and meet tight work schedule(s) and timelines
10. Ability to learn and follow all State and Federal Child Nutrition guidelines
11. Observe health and safety regulations.
12. Observe legal and defensive driving practices.
13. Understand and follow oral and written instructions.
14. Add, subtract, multiply and divide quickly and accurately.
15. Communicate effectively both orally and in writing.
16. Establish and maintain cooperative and effective working relationships with others
17. Maintain regular and consistent attendance.

added



EDUCATION AND EXPERIENCE:

Any combination of equivalent to sufficient experience, training and/or education to demonstrate the knowledge and abilities listed above. Typically, this would be gained through graduation from high school and one year warehouse, delivery related experience.

LICENSES AND OTHER REQUIREMENTS:

1. Valid California driver's license
2. Valid Forklift Certification.
3. Valid ServSafe Certification, which can be obtained through the District

WORKING CONDITIONS:

1. Subject to exposure to sunlight and other outside conditions.
2. Subject to working in adverse weather conditions.
3. Work involves heavy physical exertion.
4. Driving a vehicle to conduct work.
5. Subject to sitting, bending or stooping, lifting, climbing stairs, ladders, standing, and walking
6. Work in areas of extreme temperature change, i.e. freezer and refrigerator.

added

*

PHYSICAL ABILITIES:

1. Dexterity of hands and fingers to operate a variety of warehouse equipment.
2. Hearing and speaking to exchange information.
3. Seeing to read a variety of materials.
4. Sitting or standing, walking for extended periods of time.
5. Mobility to climb stairs and ladders bending at the waist, kneeling and crouching.
6. Reaching overhead and above shoulders; lifting, carrying, pushing, or pulling objects weighing up to seventy-five (75) pounds; pushing students in a wheelchair.

added

RIO SCHOOL DISTRICT IS AN EQUAL OPPORTUNITY/AFFIRMATIVE ACTION EMPLOYER
RIO PROVIDES A TOBACCO FREE ENVIRONMENT

9.13



Agenda Item Details

Meeting	Mar 17, 2021 - RSD Regular Board Meeting
Category	9. Discussion/Action
Subject	9.13 Approval of Request to Bid Project #12-12L at Rio Del Valle for the Sports Field Complex, Phase 1
Access	Public
Type	Action
Recommended Action	It is recommended that the Board approve the District to request bids for Project #12-12L at Rio Del Valle for the Sports Field Complex, Phase 1.

Public Content

Speaker:
Wael Saleh, Assistant Superintendent, Business Services

Rationale:
It is requested that the Board approve the District to Bid the Rio Del Valle Sports Field Complex, Phase I project. Plans should arrive by the end of the month and with the Board approval to go ahead and bid the project, we can move forward with assembling a bid package and soliciting bids to award and construct this project.

21-12L RDV PH#1 Sportsfield Project Request for Board Approval to Bid Project 3 4 21 (1) (1).pdf (34 KB)

Administrative Content

Executive Content

Rio School District
1800 Solar, 3rd Floor
Oxnard, CA 93036
Attn: Dr. John Puglisi, Superintendent

March 4, 2021

Subject: Request for Board Approval to Bid Phase #1 Sports Field Project RDV

Re: RSD Project #21-12L Rio Del Valle Phase #1 Sports Field Project, RDV

Dear Members of the Rio School District Board of Education and Dr. Puglisi,

Balfour Beatty Construction would like to obtain approval from the Rio School Districts Board of Education and Superintendent of the District to move forward with assembling bids, and solicit Contractors for the following Construction project related to the installation of the Phase #1 Sports Field Project at Rio Del Valle Middle School. The Rio School District has been informed that they will be taking delivery of the Project Plans by March 26, 2021 for bidding and construction.

Balfour Beatty Construction is requesting Approval to Solicit Bids for the following Project:

- 1) RSD Project #21-012L Phase #1 Sports Field Project at Rio Del Valle Middle School.
The Estimated Budget to Construct this project is \$4,000,000.00

The Project listed above that we have requested approval to bid will receive the DSA Approved plan on or about March 26, 2021. Balfour Beatty is of the opinion that it is in the best interest of the Rio School District to approve and move forward with this very important project previously requested as a priority by the Staff at Rio Del Valle and the Rio Board of Education.

It is therefore Balfour Beatty Constructions recommendation that the Rio School District Board of Education and the Superintendent of Schools Issue an Approval to Solicit and Bid this Project.

Should you have any questions or require any additional information, please contact me at any time.

Respectfully,

KH 3/4/2021

Keith Henderson
Senior Project Manager, Balfour Beatty Construction

cc. Wael Saleh Rio S.D.
Dennis Kuykendall BBC
Jesus Muguerza Ibarra BBC

RIO SCHOOL DISTRICT

RIO DEL VALLE MIDDLE SCHOOL

SPORTS FIELDS COMPLEX - PHASE 1

3100 NORTH ROSE AVENUE, OXNARD, CA 93036

RIO SCHOOL DISTRICT
100 NORTH ROSE AVENUE, OXNARD, CA 93036
SPORTS FIELDS COMPLEX - PHASE 1

GENERAL REQUIREMENTS:

1. ALL WORK SHALL BE IN ACCORDANCE WITH THE CALIFORNIA CODE OF REGULATIONS (C.C.R.).
2. CHANGES TO THE APPROVED DRAWINGS AND SPECIFICATIONS SHALL BE MADE BY ADDITION OR DELETION OF NOTES APPROVED BY THE DISTRICT ARCHITECT.
3. THE WORK SHALL BE COMPLETED WITHIN THE SPECIFIED TIME FRAME. DELAYED WORK SHALL BE PENALIZED AS PER THE DISTRICT ARCHITECT'S POLICY.
4. THE CONTRACTOR SHALL BE RESPONSIBLE FOR OBTAINING ALL NECESSARY PERMITS AND APPROVALS FROM THE LOCAL JURISDICTIONS. THE CONTRACTOR SHALL BE RESPONSIBLE FOR OBTAINING ALL NECESSARY PERMITS AND APPROVALS FROM THE LOCAL JURISDICTIONS.
5. THE CONTRACTOR SHALL BE RESPONSIBLE FOR OBTAINING ALL NECESSARY PERMITS AND APPROVALS FROM THE LOCAL JURISDICTIONS. THE CONTRACTOR SHALL BE RESPONSIBLE FOR OBTAINING ALL NECESSARY PERMITS AND APPROVALS FROM THE LOCAL JURISDICTIONS.

GENERAL NOTES:

1. ANY DISCREPANCY BETWEEN THE EXISTING CONDITIONS AS OBSERVED AND THE CONTRACT DOCUMENTS SHALL BE REPORTED TO THE ARCHITECT BEFORE PROCEEDING WITH THE WORK.
2. THE CONTRACTOR SHALL VERIFY ALL DIMENSIONS PRIOR TO STARTING WORK. DIMENSIONS SHALL BE MEASURED FROM THE FACE UNLESS OTHERWISE NOTED.
3. ANY DAMAGE TO EXISTING UTILITIES OR STRUCTURES DURING THE CONSTRUCTION SHALL BE REPAIRED AT THE CONTRACTOR'S EXPENSE. THE CONTRACTOR SHALL BE RESPONSIBLE FOR OBTAINING ALL NECESSARY PERMITS AND APPROVALS FROM THE LOCAL JURISDICTIONS.
4. IT SHALL BE THE RESPONSIBILITY OF THE GENERAL CONTRACTOR TO OBTAIN ALL NECESSARY PERMITS AND APPROVALS FROM THE LOCAL JURISDICTIONS.
5. BEFORE ANY WORK BEGINS, THE CONTRACTOR SHALL VERIFY THE EXISTING CONDITIONS AND THE INTENT OF THESE DRAWINGS AND SPECIFICATIONS. THE CONTRACTOR SHALL BE RESPONSIBLE FOR OBTAINING ALL NECESSARY PERMITS AND APPROVALS FROM THE LOCAL JURISDICTIONS.
6. ANY DAMAGE TO EXISTING UTILITIES OR STRUCTURES DURING THE CONSTRUCTION SHALL BE REPAIRED AT THE CONTRACTOR'S EXPENSE. THE CONTRACTOR SHALL BE RESPONSIBLE FOR OBTAINING ALL NECESSARY PERMITS AND APPROVALS FROM THE LOCAL JURISDICTIONS.
7. BEFORE ANY WORK BEGINS, THE CONTRACTOR SHALL VERIFY THE EXISTING CONDITIONS AND THE INTENT OF THESE DRAWINGS AND SPECIFICATIONS. THE CONTRACTOR SHALL BE RESPONSIBLE FOR OBTAINING ALL NECESSARY PERMITS AND APPROVALS FROM THE LOCAL JURISDICTIONS.
8. THE CONTRACTOR SHALL BE RESPONSIBLE FOR OBTAINING ALL NECESSARY PERMITS AND APPROVALS FROM THE LOCAL JURISDICTIONS. THE CONTRACTOR SHALL BE RESPONSIBLE FOR OBTAINING ALL NECESSARY PERMITS AND APPROVALS FROM THE LOCAL JURISDICTIONS.
9. THE CONTRACTOR SHALL BE RESPONSIBLE FOR OBTAINING ALL NECESSARY PERMITS AND APPROVALS FROM THE LOCAL JURISDICTIONS. THE CONTRACTOR SHALL BE RESPONSIBLE FOR OBTAINING ALL NECESSARY PERMITS AND APPROVALS FROM THE LOCAL JURISDICTIONS.
10. THE CONTRACTOR SHALL BE RESPONSIBLE FOR OBTAINING ALL NECESSARY PERMITS AND APPROVALS FROM THE LOCAL JURISDICTIONS. THE CONTRACTOR SHALL BE RESPONSIBLE FOR OBTAINING ALL NECESSARY PERMITS AND APPROVALS FROM THE LOCAL JURISDICTIONS.
11. THE CONTRACTOR SHALL BE RESPONSIBLE FOR OBTAINING ALL NECESSARY PERMITS AND APPROVALS FROM THE LOCAL JURISDICTIONS. THE CONTRACTOR SHALL BE RESPONSIBLE FOR OBTAINING ALL NECESSARY PERMITS AND APPROVALS FROM THE LOCAL JURISDICTIONS.

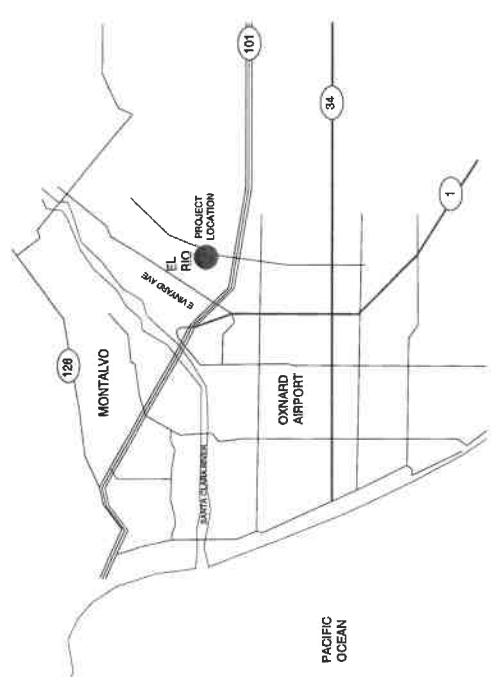

PROJECT AREA VICINITY MAP
SCALE: 1/4" = 100'

APPLICABLE CODES

- CONSTRUCTION SHALL COMPLY WITH THE FOLLOWING:
- PART 1 2014 CALIFORNIA ADMINISTRATIVE CODE (CAL. TITLE 16 C.C.R.)
 - PART 2 2014 CALIFORNIA BUILDING CODE (CBC), TITLE 18 C.C.R.
 - PART 3 2014 CALIFORNIA ELECTRICAL CODE (CEC), TITLE 16 C.C.R.
 - PART 4 2014 CALIFORNIA MECHANICAL CODE (CMC), TITLE 16 C.C.R.
 - PART 5 2014 CALIFORNIA PLUMBING CODE (CPC), TITLE 16 C.C.R.
 - PART 6 2014 CALIFORNIA FIRE PREVENTION CODE (FPC), TITLE 16 C.C.R.
 - PART 7 2014 CALIFORNIA FIRE SAFETY CODE (FSC), TITLE 16 C.C.R.
 - PART 8 2014 CALIFORNIA HAZARDOUS WASTE CODE (HWEC), TITLE 16 C.C.R.
 - PART 9 2014 CALIFORNIA HAZARDOUS WASTE REGULATIONS (HWER), TITLE 16 C.C.R.
 - PART 10 2014 CALIFORNIA HAZARDOUS WASTE REGULATIONS (HWER), TITLE 16 C.C.R.
 - PART 11 2014 CALIFORNIA HAZARDOUS WASTE REGULATIONS (HWER), TITLE 16 C.C.R.
 - PART 12 2014 CALIFORNIA HAZARDOUS WASTE REGULATIONS (HWER), TITLE 16 C.C.R.

SYMBOL LEGEND

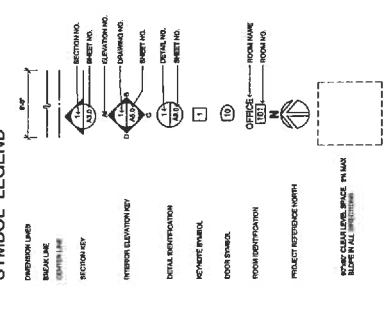

PROJECT TEAM

- ARCHITECT:**
KSCHEIBEN ZEMER ARCHITECTS, INC.
10000 WILSON AVENUE, SUITE 100
DUBLIN, CA 94568
TEL: (925) 835-1000
WWW.KSCHEIBENZEMER.COM
- GENERAL CONTRACTOR:**
KSCHEIBEN ZEMER ARCHITECTS, INC.
10000 WILSON AVENUE, SUITE 100
DUBLIN, CA 94568
TEL: (925) 835-1000
WWW.KSCHEIBENZEMER.COM
- MECHANICAL ENGINEER:**
KSCHEIBEN ZEMER ARCHITECTS, INC.
10000 WILSON AVENUE, SUITE 100
DUBLIN, CA 94568
TEL: (925) 835-1000
WWW.KSCHEIBENZEMER.COM
- ELECTRICAL ENGINEER:**
KSCHEIBEN ZEMER ARCHITECTS, INC.
10000 WILSON AVENUE, SUITE 100
DUBLIN, CA 94568
TEL: (925) 835-1000
WWW.KSCHEIBENZEMER.COM
- PLUMBING ENGINEER:**
KSCHEIBEN ZEMER ARCHITECTS, INC.
10000 WILSON AVENUE, SUITE 100
DUBLIN, CA 94568
TEL: (925) 835-1000
WWW.KSCHEIBENZEMER.COM

PROJECT SCOPE

- THE SCOPE OF WORK IS TO PROVIDE THE ENTIRETY OF THE SPORTS FIELDS COMPLEX, INCLUDING THE CONSTRUCTION OF THE SPORTS FIELDS, STADIUM, AND RELATED INFRASTRUCTURE. THE CONTRACTOR SHALL BE RESPONSIBLE FOR OBTAINING ALL NECESSARY PERMITS AND APPROVALS FROM THE LOCAL JURISDICTIONS.

PROJECT INFORMATION

- OWNER:** RIO SCHOOL DISTRICT
PROJECT LOCATION: 3100 NORTH ROSE AVENUE, OXNARD, CA 93036
ARCHITECT: KSCHEIBEN ZEMER ARCHITECTS, INC.
MECHANICAL ENGINEER: KSCHEIBEN ZEMER ARCHITECTS, INC.
ELECTRICAL ENGINEER: KSCHEIBEN ZEMER ARCHITECTS, INC.
PLUMBING ENGINEER: KSCHEIBEN ZEMER ARCHITECTS, INC.

SHEET INDEX

GENERAL	TITLE SHEET: VICINITY MAP, GENERAL NOTES
0100	TITLE SHEET: VICINITY MAP, GENERAL NOTES
0101	TITLE SHEET
0102	GENERAL NOTES
0103	GENERAL NOTES
0104	GENERAL NOTES
0105	GENERAL NOTES
0106	GENERAL NOTES
0107	GENERAL NOTES
0108	GENERAL NOTES
0109	GENERAL NOTES
0110	GENERAL NOTES
0111	GENERAL NOTES
0112	GENERAL NOTES
0113	GENERAL NOTES
0114	GENERAL NOTES
0115	GENERAL NOTES
0116	GENERAL NOTES
0117	GENERAL NOTES
0118	GENERAL NOTES
0119	GENERAL NOTES
0120	GENERAL NOTES
0121	GENERAL NOTES
0122	GENERAL NOTES
0123	GENERAL NOTES
0124	GENERAL NOTES
0125	GENERAL NOTES
0126	GENERAL NOTES
0127	GENERAL NOTES
0128	GENERAL NOTES
0129	GENERAL NOTES
0130	GENERAL NOTES
0131	GENERAL NOTES
0132	GENERAL NOTES
0133	GENERAL NOTES
0134	GENERAL NOTES
0135	GENERAL NOTES
0136	GENERAL NOTES
0137	GENERAL NOTES
0138	GENERAL NOTES
0139	GENERAL NOTES
0140	GENERAL NOTES
0141	GENERAL NOTES
0142	GENERAL NOTES
0143	GENERAL NOTES
0144	GENERAL NOTES
0145	GENERAL NOTES
0146	GENERAL NOTES
0147	GENERAL NOTES
0148	GENERAL NOTES
0149	GENERAL NOTES
0150	GENERAL NOTES
0151	GENERAL NOTES
0152	GENERAL NOTES
0153	GENERAL NOTES
0154	GENERAL NOTES
0155	GENERAL NOTES
0156	GENERAL NOTES
0157	GENERAL NOTES
0158	GENERAL NOTES
0159	GENERAL NOTES
0160	GENERAL NOTES
0161	GENERAL NOTES
0162	GENERAL NOTES
0163	GENERAL NOTES
0164	GENERAL NOTES
0165	GENERAL NOTES
0166	GENERAL NOTES
0167	GENERAL NOTES
0168	GENERAL NOTES
0169	GENERAL NOTES
0170	GENERAL NOTES
0171	GENERAL NOTES
0172	GENERAL NOTES
0173	GENERAL NOTES
0174	GENERAL NOTES
0175	GENERAL NOTES
0176	GENERAL NOTES
0177	GENERAL NOTES
0178	GENERAL NOTES
0179	GENERAL NOTES
0180	GENERAL NOTES
0181	GENERAL NOTES
0182	GENERAL NOTES
0183	GENERAL NOTES
0184	GENERAL NOTES
0185	GENERAL NOTES
0186	GENERAL NOTES
0187	GENERAL NOTES
0188	GENERAL NOTES
0189	GENERAL NOTES
0190	GENERAL NOTES
0191	GENERAL NOTES
0192	GENERAL NOTES
0193	GENERAL NOTES
0194	GENERAL NOTES
0195	GENERAL NOTES
0196	GENERAL NOTES
0197	GENERAL NOTES
0198	GENERAL NOTES
0199	GENERAL NOTES
0200	GENERAL NOTES

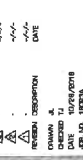
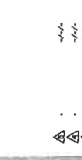

SPORTS FIELDS COMPLEX - PHASE I
 RIO DEL VALLE MIDDLE SCHOOL
 RIO SCHOOL DISTRICT
 3100 NORTH ROSE AVENUE, CHANDLER, CA 94926



KRUGER BENSON ZIEEMER ARCHITECTS, INC.
 10000 UNIVERSITY AVENUE, SUITE 100
 SAN DIEGO, CA 92121
 TEL: 619-591-1100
 FAX: 619-591-1101
 WWW.KRUGERBENZONZIEEMER.COM

TODD A. JESPERSEN, AIA
 JONATHAN D. LEE
 ARCHITECTS

REGISTERED ARCHITECTS
 STATE OF CALIFORNIA
 ARCHITECT NO. 45812
 ARCHITECT NO. 45813



NO.	DATE	BY
1	11/11/2011	JDL
2	11/11/2011	JDL
3	11/11/2011	JDL
4	11/11/2011	JDL
5	11/11/2011	JDL
6	11/11/2011	JDL
7	11/11/2011	JDL
8	11/11/2011	JDL
9	11/11/2011	JDL
10	11/11/2011	JDL
11	11/11/2011	JDL
12	11/11/2011	JDL
13	11/11/2011	JDL
14	11/11/2011	JDL
15	11/11/2011	JDL
16	11/11/2011	JDL
17	11/11/2011	JDL
18	11/11/2011	JDL
19	11/11/2011	JDL
20	11/11/2011	JDL
21	11/11/2011	JDL
22	11/11/2011	JDL
23	11/11/2011	JDL
24	11/11/2011	JDL
25	11/11/2011	JDL
26	11/11/2011	JDL
27	11/11/2011	JDL
28	11/11/2011	JDL
29	11/11/2011	JDL
30	11/11/2011	JDL
31	11/11/2011	JDL
32	11/11/2011	JDL
33	11/11/2011	JDL
34	11/11/2011	JDL
35	11/11/2011	JDL
36	11/11/2011	JDL
37	11/11/2011	JDL
38	11/11/2011	JDL
39	11/11/2011	JDL
40	11/11/2011	JDL
41	11/11/2011	JDL
42	11/11/2011	JDL
43	11/11/2011	JDL
44	11/11/2011	JDL
45	11/11/2011	JDL
46	11/11/2011	JDL
47	11/11/2011	JDL
48	11/11/2011	JDL
49	11/11/2011	JDL
50	11/11/2011	JDL
51	11/11/2011	JDL
52	11/11/2011	JDL
53	11/11/2011	JDL
54	11/11/2011	JDL
55	11/11/2011	JDL
56	11/11/2011	JDL
57	11/11/2011	JDL
58	11/11/2011	JDL
59	11/11/2011	JDL
60	11/11/2011	JDL
61	11/11/2011	JDL
62	11/11/2011	JDL
63	11/11/2011	JDL
64	11/11/2011	JDL
65	11/11/2011	JDL
66	11/11/2011	JDL
67	11/11/2011	JDL
68	11/11/2011	JDL
69	11/11/2011	JDL
70	11/11/2011	JDL
71	11/11/2011	JDL
72	11/11/2011	JDL
73	11/11/2011	JDL
74	11/11/2011	JDL
75	11/11/2011	JDL
76	11/11/2011	JDL
77	11/11/2011	JDL
78	11/11/2011	JDL
79	11/11/2011	JDL
80	11/11/2011	JDL
81	11/11/2011	JDL
82	11/11/2011	JDL
83	11/11/2011	JDL
84	11/11/2011	JDL
85	11/11/2011	JDL
86	11/11/2011	JDL
87	11/11/2011	JDL
88	11/11/2011	JDL
89	11/11/2011	JDL
90	11/11/2011	JDL
91	11/11/2011	JDL
92	11/11/2011	JDL
93	11/11/2011	JDL
94	11/11/2011	JDL
95	11/11/2011	JDL
96	11/11/2011	JDL
97	11/11/2011	JDL
98	11/11/2011	JDL
99	11/11/2011	JDL
100	11/11/2011	JDL

PROJ. NO. 11-0001
 DRAWN BY JDL
 CHECKED BY JDL
 DATE 11/11/2011
 JOB NO. 11-0001
 SHEET EXISTING DRAINAGE MAP
 TITLE

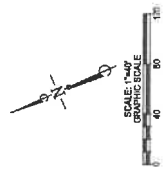

11/11/2011

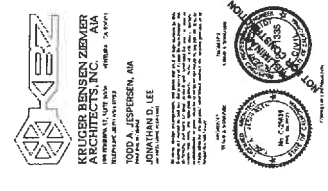

PROJECT: CD-1-A1
 SHEET: 11-11 (11 OF 16)
 DATE: 11/27/2018
 DRAWN BY: [Signature]
 CHECKED BY: [Signature]
 DESIGNED BY: [Signature]
 REVISED BY: [Signature]
 DATE: [Signature]
 TITLE: DETAILS
 PROJECT: CD-1-A1

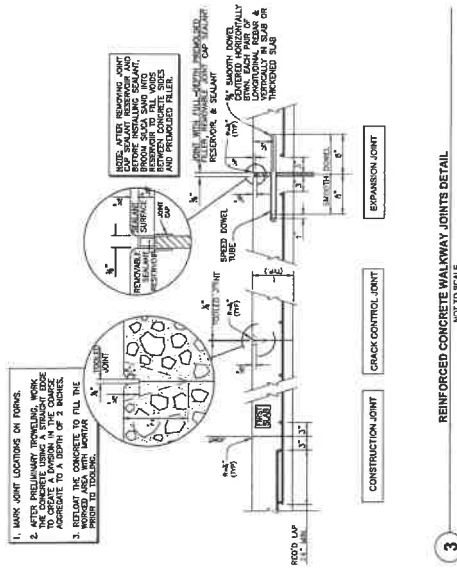

REINFORCED CONCRETE WALKWAY JOINTS DETAIL
NOT TO SCALE

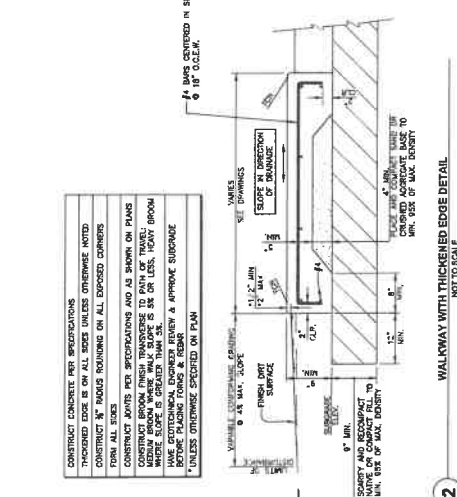

WALKWAY WITH THICKENED EDGE DETAIL
NOT TO SCALE

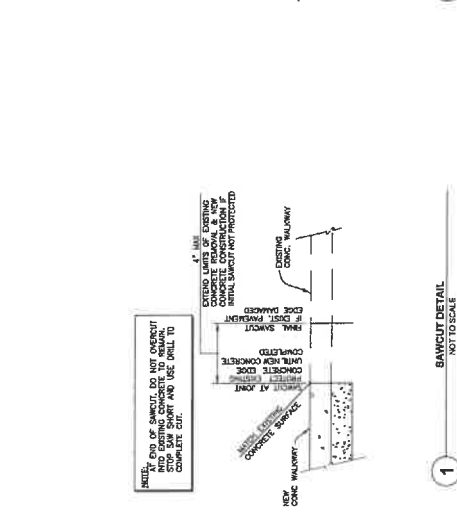

BANKSUF DETAIL
NOT TO SCALE

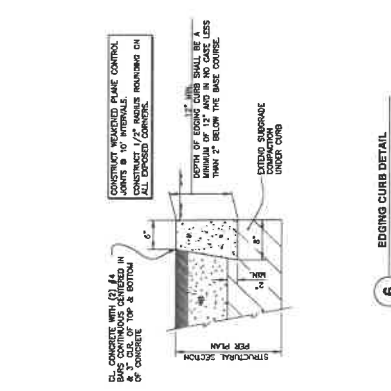

TYPICAL A.C. PAVEMENT STRUCTURAL SECTION
NOT TO SCALE

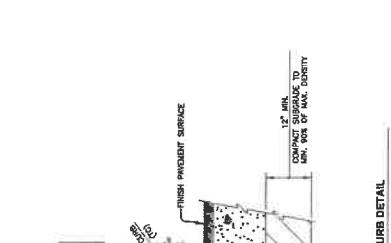

8" CURB DETAIL
NOT TO SCALE

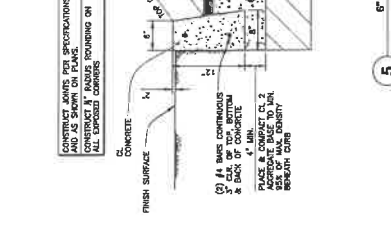

EDGING CURB DETAIL
NOT TO SCALE

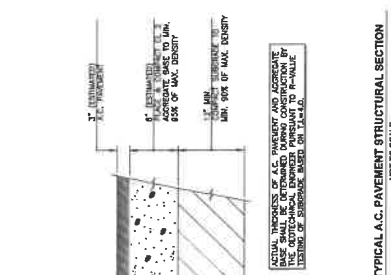

DETECTABLE WARNING PAVEMENT IN CONCRETE DETAIL
NOT TO SCALE

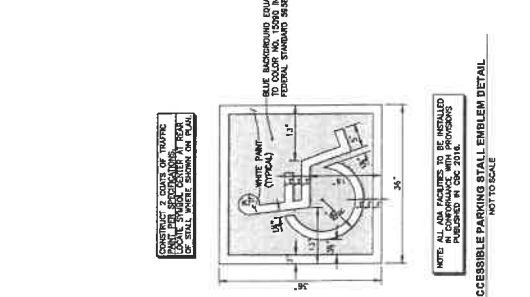

TYPICAL ACCESSIBLE PARKING STALL LAYOUT DETAIL
NOT TO SCALE

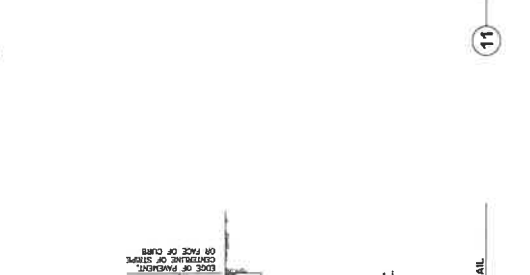

TRUNCATED DOME DETAIL
NOT TO SCALE

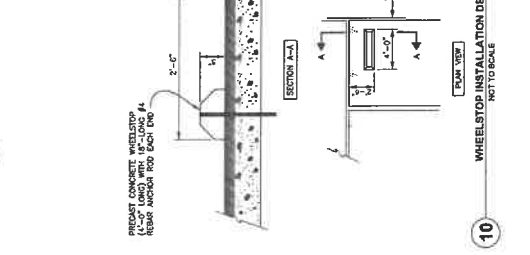

WHEELSTOP INSTALLATION DETAIL
NOT TO SCALE

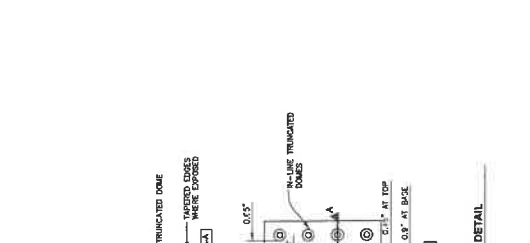

ACCESSIBLE PARKING STALL ENBLEM DETAIL
NOT TO SCALE

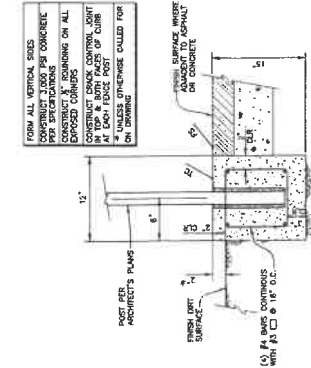

12 MOW STRIP WITH FENCE POST DETAIL
NOT TO SCALE

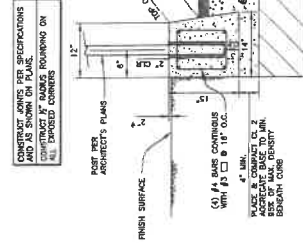

13 CURB WITH FENCE POST DETAIL
NOT TO SCALE

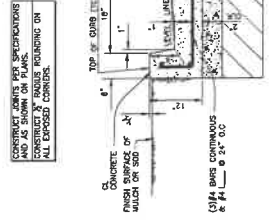

14 CURB AND GUTTER WITH FENCE POST DETAIL
NOT TO SCALE

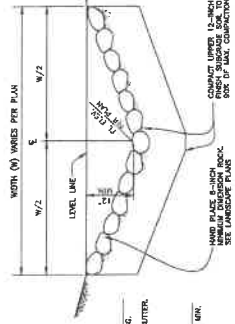

15 ROCK LINED SWALE
NOT TO SCALE

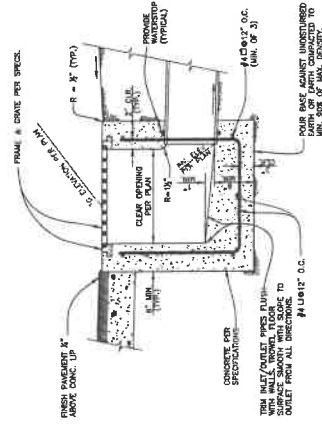

16 TYPICAL DECOMPOSED GRANITE STRUCTURAL SECTION
NOT TO SCALE

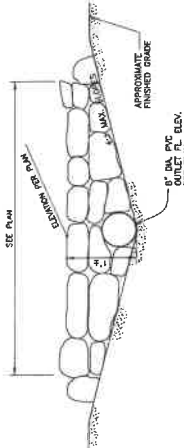

17 DRAINAGE HEADWALL OUTLET DETAIL
NOT TO SCALE

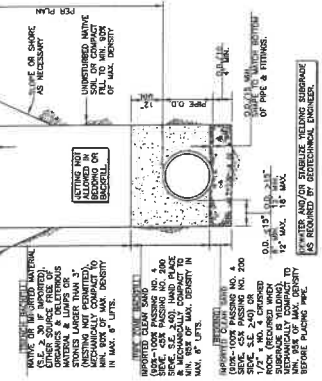

18 PIPE TRENCH FOR NEW CONSTRUCTION
NOT TO SCALE

SPORTS FIELDS COMPLEX - PHASE I
 RIO DEL VALLE MIDDLE SCHOOL
 RIO SCHOOL DISTRICT
 1100 NORTH ROSE AVENUE, OAKLAND, CA 94612



KRUGER BENSON ZIEMER ARCHITECTS, INC. AA
 1100 NORTH ROSE AVENUE, SUITE 200
 OAKLAND, CA 94612

TODD A. JEFFERSON, AA
 JONATHAN D. LEE
 ARCHITECTS

REGISTERED ARCHITECTS
 STATE OF CALIFORNIA
 ARCHITECT NO. 10000
 ARCHITECT NO. 10000



NO.	DATE	DESCRIPTION
1	11/11/11	PRELIMINARY
2	11/11/11	REVISED
3	11/11/11	REVISED
4	11/11/11	REVISED
5	11/11/11	REVISED
6	11/11/11	REVISED
7	11/11/11	REVISED
8	11/11/11	REVISED
9	11/11/11	REVISED
10	11/11/11	REVISED

DATE: 11/11/11
 DRAWN BY: [Name]
 CHECKED BY: [Name]
 DATE: 11/11/11
 MEET: 11/11/11
 TITLE: [Title]

TWET
EC-1-A1

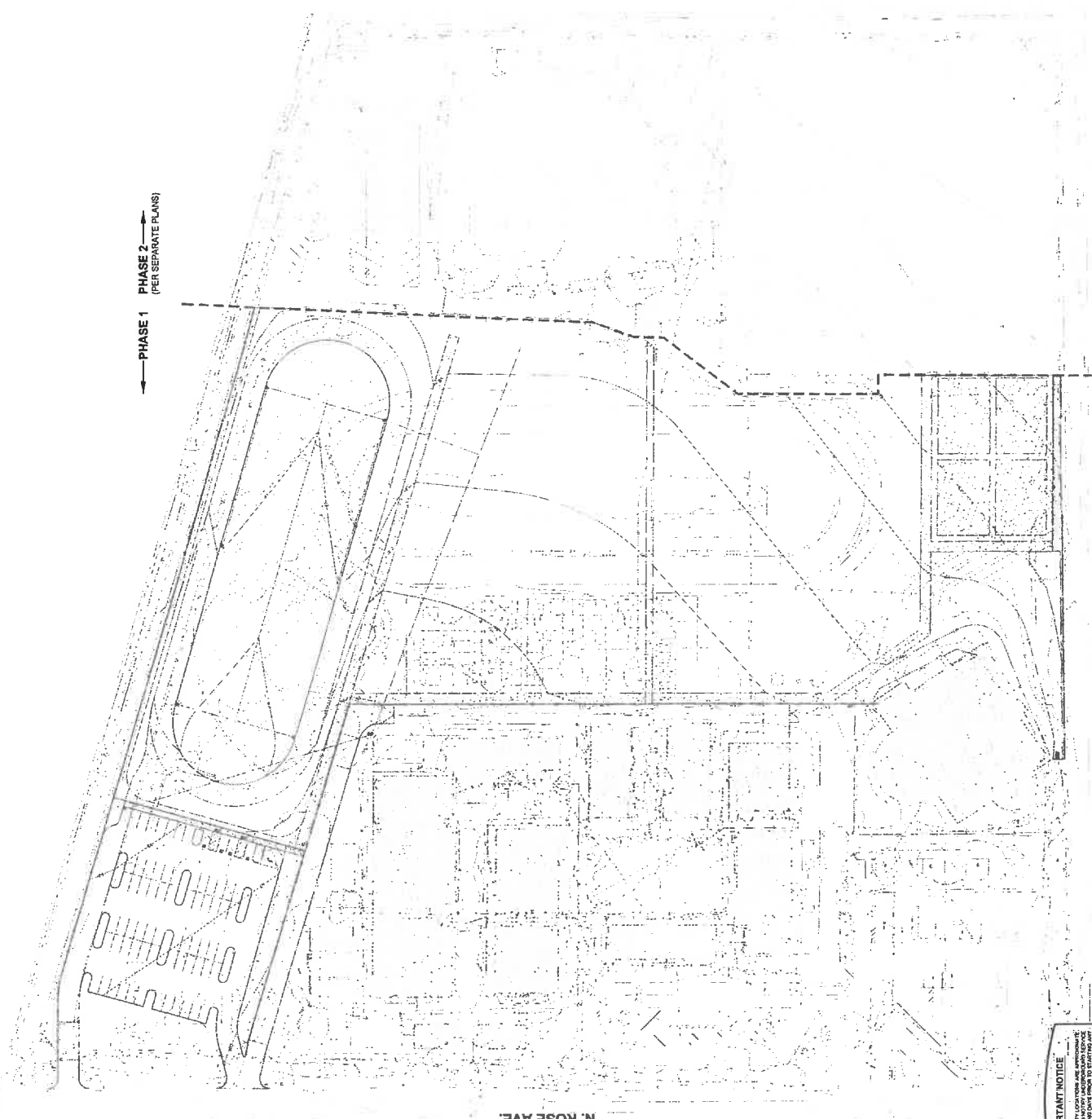

← PHASE 1
 PHASE 2 →
 (PER SEPARATE PLANS)

N ROSE AVE.

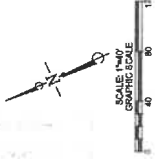

IMPORTANT NOTICE
 ALL SPORTS UTILITY LOCATIONS ARE APPROXIMATE.
 ALL SPORTS UTILITY LOCATIONS SHOULD BE VERIFIED BY
 A UTILITY LOCATOR PRIOR TO STARTING ANY
 CONSTRUCTION OR REPAIRS.
 CALL TOLL FREE 1-800-421-1111

KLUGER BENBEN ZEMVER ARCHITECTS, INC.
 1000 UNIVERSITY AVENUE, SUITE 200, BERKELEY, CA 94702
 TEL: (925) 841-1000 FAX: (925) 841-1001
 WWW.KBZARCHITECTS.COM

JOHN W. LEE
 PROJECT ARCHITECT
 1000 UNIVERSITY AVENUE, SUITE 200, BERKELEY, CA 94702
 TEL: (925) 841-1000 FAX: (925) 841-1001
 WWW.KBZARCHITECTS.COM

DATE: 10/26/2019
JOB NO.: 15020A
SHEET: SEE EXHIBIT
SCALE: 1/8" = 1'-0"

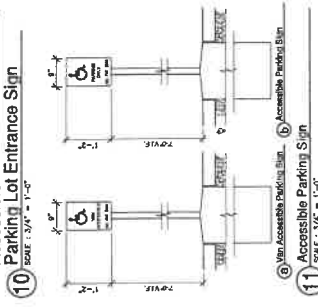
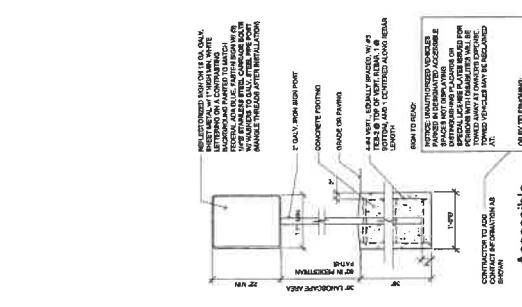
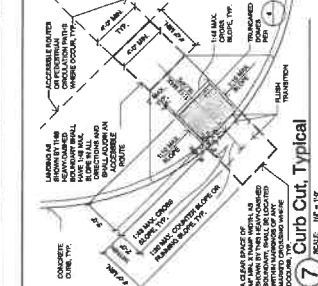
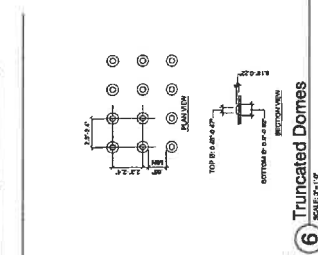
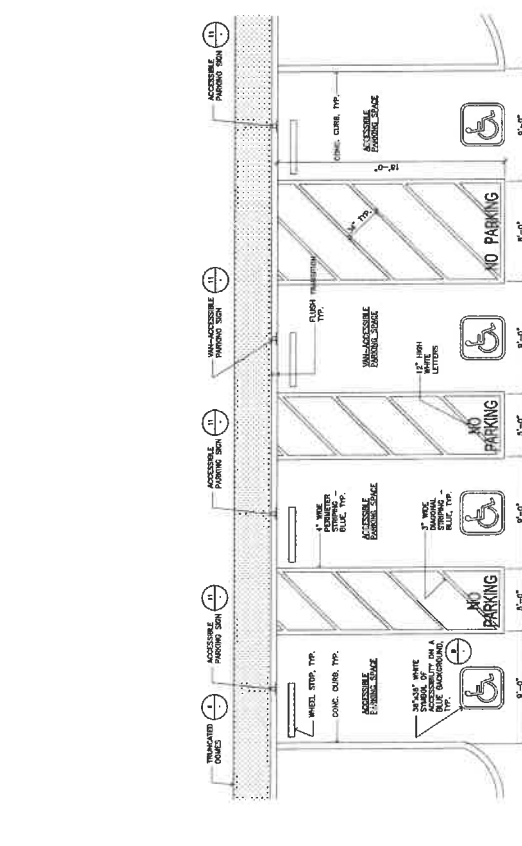
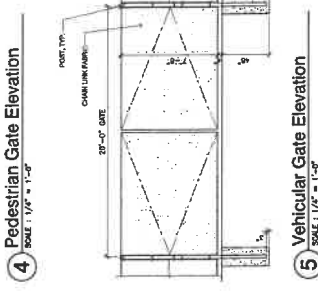
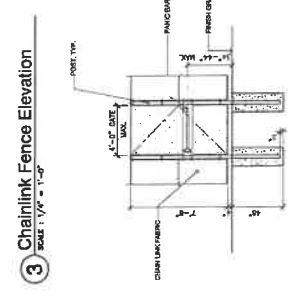
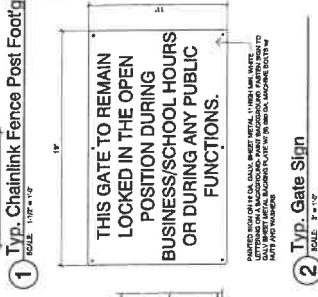
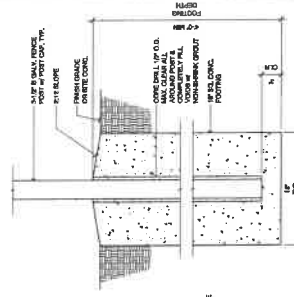
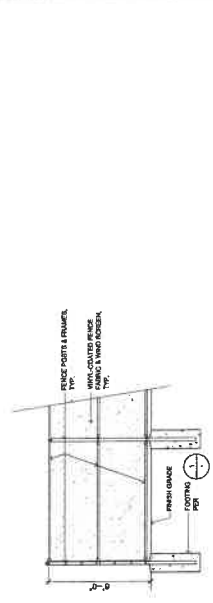

SITE PLAN KEYNOTES

- 1. 10' WIDE FOOTPATH ACCESS CURET
- 2. 10' WIDE EMERGENCY ESCAPE ALLEYS
- 3. PARKING LOT EXISTENCE SIGN REQUIREMENTS
- 4. CURRENT ACCESSIBILITY CODE REQUIREMENTS
- 5. CURRENT ACCESSIBILITY CODE REQUIREMENTS WITH THE CURB CUT ACCOMMODATION FOR VISUAL IMPAIRMENT
- 6. CURRENT ACCESSIBILITY CODE REQUIREMENTS WITH THE CURB CUT ACCOMMODATION FOR VISUAL IMPAIRMENT
- 7. CURB CUT
- 8. CURB CUT

SITE PLAN LEGEND

- OCCUPANED CHAIRS
- CONCRETE PAVING
- ASPHALT PAVING
- PERIMETER FENCE

PARKING LOT ANALYSIS

TOTAL NUMBER STANDARD PARKING SPACES : 14
 NUMBER OF ACCESSIBLE PARKING SPACES : 1
 NUMBER OF VAN ACCESSIBLE PARKING SPACES : 1

GENERAL NOTES

1. PROVIDE ALL LISTING STRUCTURES, UTILITIES & LANDSCAPE USING CONSTRUCTION.
2. PLANS HAVE BEEN PREPARED USING MANUAL DRAWINGS DERIVED FROM THE MEASUREMENT OF THE EXISTING SITE. THE DRAWINGS ARE THE ACTUAL CONDITIONS PRIOR TO START OF WORK AND NOT BE ADAPTED TO ANY DISCREPANCIES.

PATH OF TRAVEL

ALL PATHS OF TRAVEL SHALL BE PROVIDED AT THE POINT OF ENTRY TO THE PROJECT. AT EACH OF THE ENTRANCES TO THE PROJECT, THERE SHALL BE PROVIDED A MINIMUM OF ONE (1) PATH OF TRAVEL TO THE MAIN ENTRANCE OF THE PROJECT. THE PATH OF TRAVEL SHALL BE PROVIDED AS A MINIMUM OF ONE (1) PATH OF TRAVEL TO THE MAIN ENTRANCE OF THE PROJECT. THE PATH OF TRAVEL SHALL BE PROVIDED AS A MINIMUM OF ONE (1) PATH OF TRAVEL TO THE MAIN ENTRANCE OF THE PROJECT. THE PATH OF TRAVEL SHALL BE PROVIDED AS A MINIMUM OF ONE (1) PATH OF TRAVEL TO THE MAIN ENTRANCE OF THE PROJECT.

THE CONTRACTOR SHALL BE RESPONSIBLE FOR OBTAINING ALL NECESSARY PERMITS FROM THE LOCAL GOVERNMENT AGENCIES. THE CONTRACTOR SHALL BE RESPONSIBLE FOR OBTAINING ALL NECESSARY PERMITS FROM THE LOCAL GOVERNMENT AGENCIES. THE CONTRACTOR SHALL BE RESPONSIBLE FOR OBTAINING ALL NECESSARY PERMITS FROM THE LOCAL GOVERNMENT AGENCIES. THE CONTRACTOR SHALL BE RESPONSIBLE FOR OBTAINING ALL NECESSARY PERMITS FROM THE LOCAL GOVERNMENT AGENCIES.

NO.	REVISION	DESCRIPTION	DATE
1	1	ISSUED FOR PERMITS	01/28/2019
2	1	ISSUED FOR PERMITS	01/28/2019
3	1	ISSUED FOR PERMITS	01/28/2019
4	1	ISSUED FOR PERMITS	01/28/2019
5	1	ISSUED FOR PERMITS	01/28/2019
6	1	ISSUED FOR PERMITS	01/28/2019
7	1	ISSUED FOR PERMITS	01/28/2019
8	1	ISSUED FOR PERMITS	01/28/2019
9	1	ISSUED FOR PERMITS	01/28/2019
10	1	ISSUED FOR PERMITS	01/28/2019

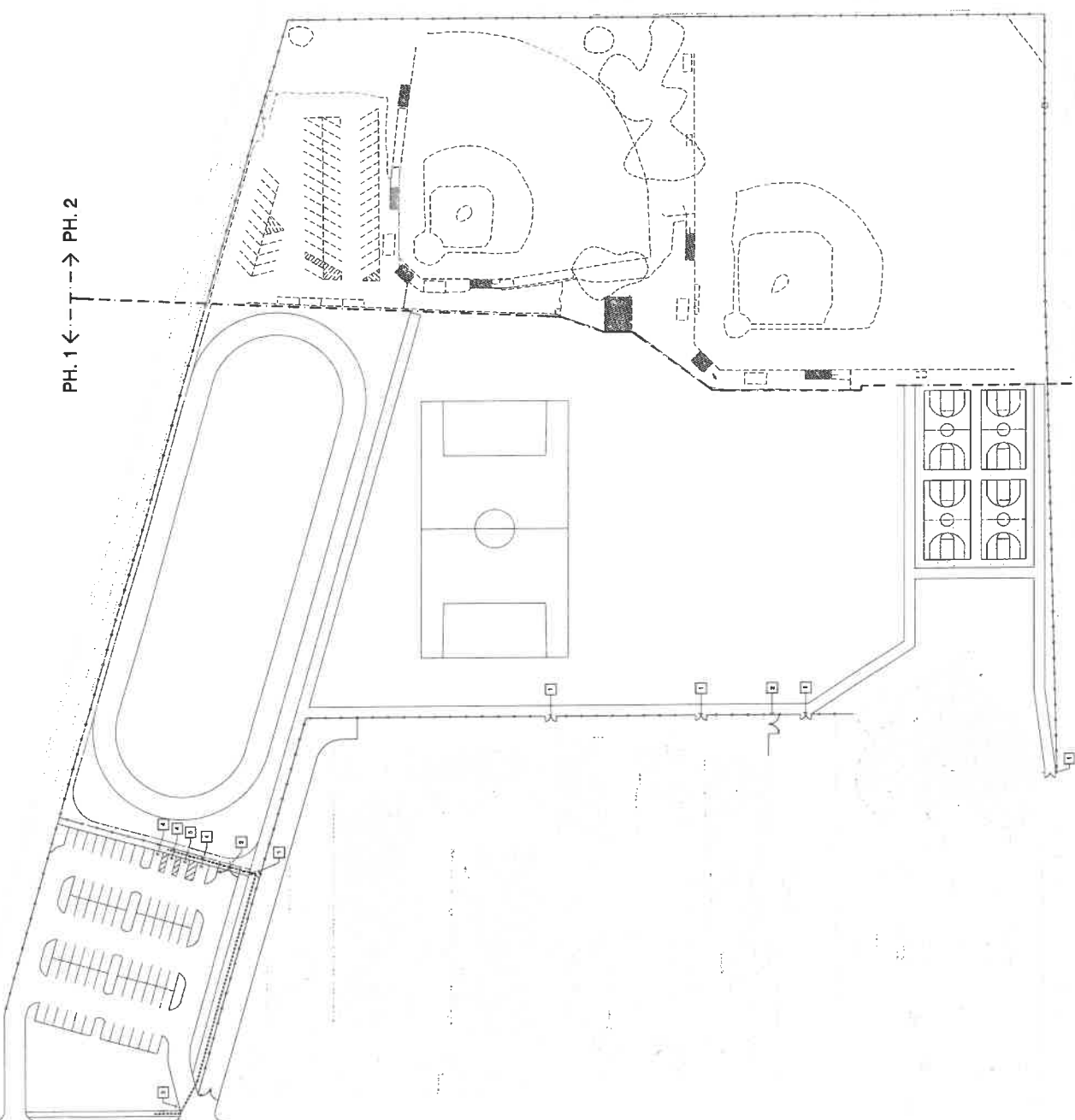

1 RIO DEL VALLE - SPORTS FIELDS SITE PLAN (PHASE 1 NEW / PHASE 2 DEMO)
 SCALE: 1" = 40' - 0"

CBZ
 ARCHITECTURAL ZEVIN
 ARCHITECTS
 1100 NORTH RICHMOND AVENUE, SUITE 100
 CHANDLER, AZ 85226
 PHOENIX, AZ 85016
 (480) 831-1111
 WWW.CBZARCHITECTS.COM





ARKENS SENYER ZEMER AA
 ARCHITECTS, INC.
 100 MONTELEONE BLVD, SUITE 1000
 HOUSTON, TEXAS 77002
 (713) 596-1000

JONATHAN D. LEE
 ARCHITECT
 100 MONTELEONE BLVD, SUITE 1000
 HOUSTON, TEXAS 77002
 (713) 596-1000



AE Group
 Mechanical Engineers, Inc.
 10000 WEST 10TH AVENUE, SUITE 1000
 DENVER, COLORADO 80201
 (303) 750-1700 FAX (303) 750-7500
 www.aegroupinc.com

LINE KEY PLAN	
(W) WATER LINE	---
(B) WATER LINE	---
ABANDONED WATER LINE	---
(S) SEWER LINE	---
(B) SEWER LINE	---
ABANDONED SEWER LINE	---
STORM DRAIN	---

NOTE:
 1. EXISTING IMPROVEMENTS SHOWN ARE BASED ON THE RECORDS PROVIDED BY THE DISTRICT AS INDICATED ON THIS PLAN.
 2. FIELD SURVEY HAS BEEN CONDUCTED TO VERIFY THE LOCATION, DEPTH, AND MATERIAL OF EXISTING UTILITIES. THE LOCATION, DEPTH, AND MATERIAL OF EXISTING UTILITIES MAY VARY FROM THE RECORDS.
 3. REMOVE EXISTING PIPE THAT IS TO BE REMOVED TO THE EXISTING EXTERIOR MANHOLE OR EXISTING EXTERIOR MANHOLE REMAINS PER 4. LOCAL CODES APPLICABLE TO THE PROJECT.

PH. 1 ← PH. 2 →

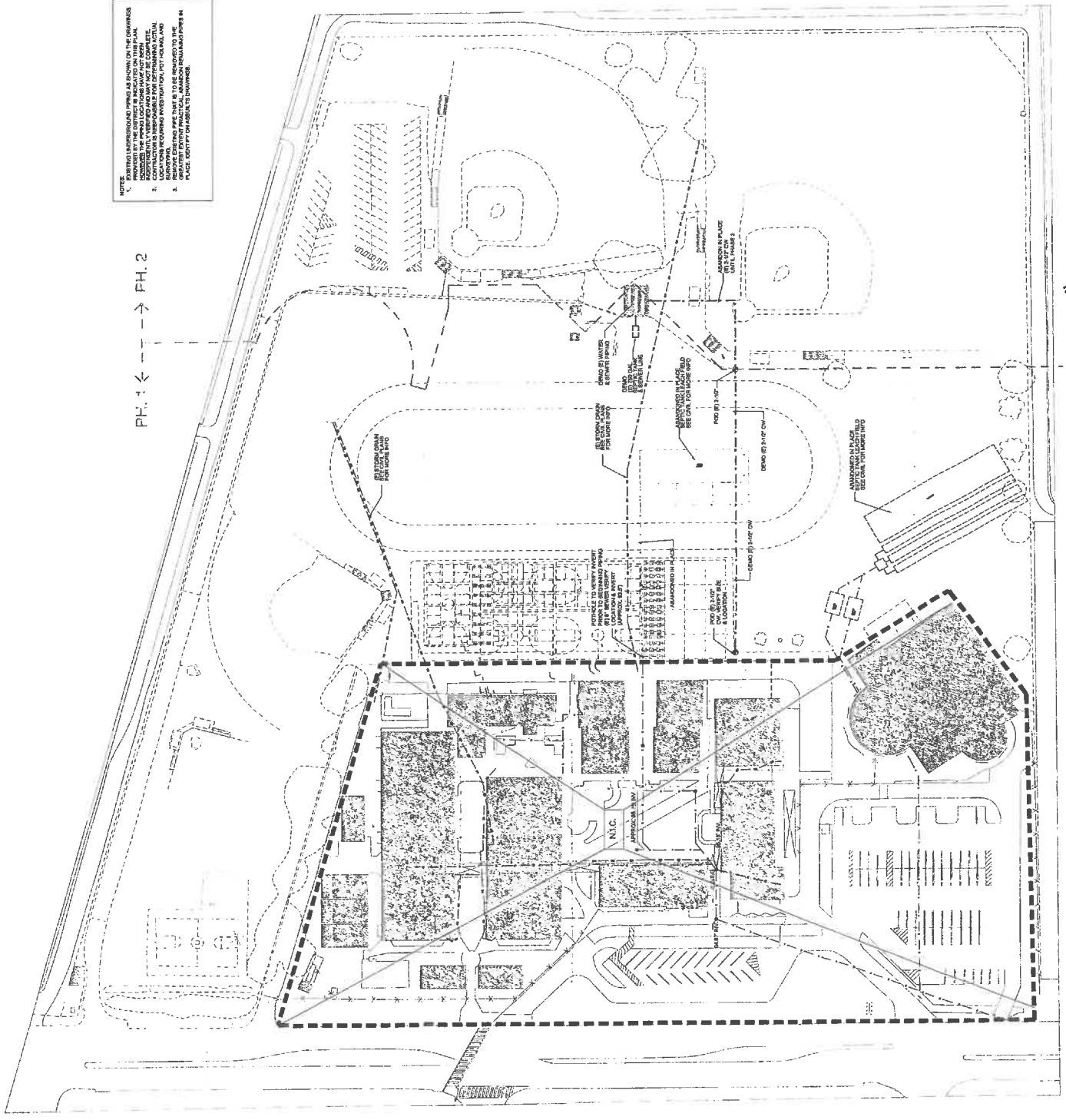



KRUGER BENDER BECKER ARCHITECTS, INC.
 1000 WEST 10TH AVENUE, SUITE 100
 DENVER, COLORADO 80202
 TEL: (303) 733-1100
 FAX: (303) 733-1101
 WWW.KRUGERBENDERBECKER.COM

TODD A. ANDERSON, AIA
 LICENSED ARCHITECT
 LICENSE NO. 100000000
 1000 WEST 10TH AVENUE, SUITE 100
 DENVER, COLORADO 80202
 TEL: (303) 733-1100
 FAX: (303) 733-1101
 WWW.KRUGERBENDERBECKER.COM



AE Group
 Mechanical Engineering, Inc.
 1000 WEST 10TH AVENUE, SUITE 100
 DENVER, COLORADO 80202
 TEL: (303) 733-1100
 FAX: (303) 733-1101
 WWW.AEGROUP.COM

SYMBOL	DESCRIPTION
(W) WATER LINE	WATER LINE
(A) ABANDONED WATER LINE	ABANDONED WATER LINE
(S) SEWER LINE	SEWER LINE
(A) ABANDONED SEWER LINE	ABANDONED SEWER LINE
(S) STORM DRAIN	STORM DRAIN

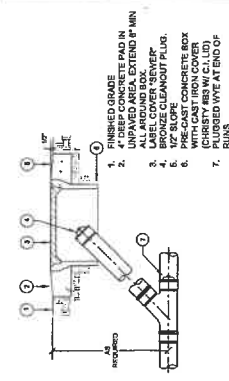

COTG DETAIL @ LANDSCAPING
 SCALE: 1/8" = 1'-0"

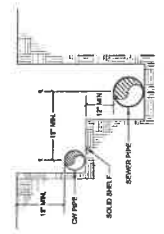

TYPICAL TRENCH & INSTALLATION OF PIPING WHERE LINES RUN PARALLEL
 SCALE: 1/8" = 1'-0"

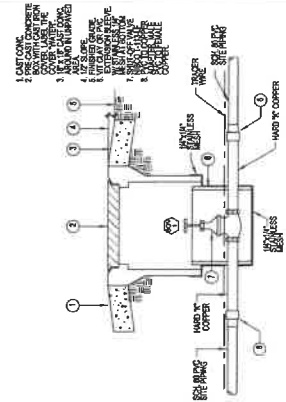

SCALE: 1/8" = 1'-0"

- NOTES:**
- BEFORE COMMENCING WORK, INDEPENDENTLY VERIFY OR DETERMINE THE PRESENCE OF EXISTING BURIED PIPELINES. VERIFY THE LOCATION AND DEPTH OF ALL BURIED UTILITIES. WORKING DRAUGHTSMEN SHALL BE RESPONSIBLE FOR ALL BURIED UTILITIES WHICH MAY AFFECT OR BE AFFECTED BY CONSTRUCTION. THIS WILL REQUIRE INVESTIGATION FOR REVIEW BEFORE WORK IS COMMENCED. ALLOW FIVE (5) WORKING DAYS FOR REVIEW.
 - IN ANY CASE, UPON BECOMING AWARE OF EXISTING BURIED PIPELINES, CONDUITS OR STRUCTURES NOT SHOWN OR LOCATED DIFFERENTLY THAN SHOWN ON THE DRAWING AND WHICH MAY AFFECT OR BE AFFECTED BY CONSTRUCTION, IMMEDIATELY NOTIFY THE OWNER'S REPRESENTATIVE BY TELEPHONE AND IN WRITING. VERIFY ALL CONNECTION SIZES.
 - CUT, PATCH, AND PAINT FINISHED SURFACES AS REQUIRED.
 - REPAIR ANY DAMAGED (B) PIPING, DO NOT COVER UNTIL RECEIVING POSITIVE APPROVAL FROM INSPECTOR.
- P.H. 1 ← T → P.H. 2

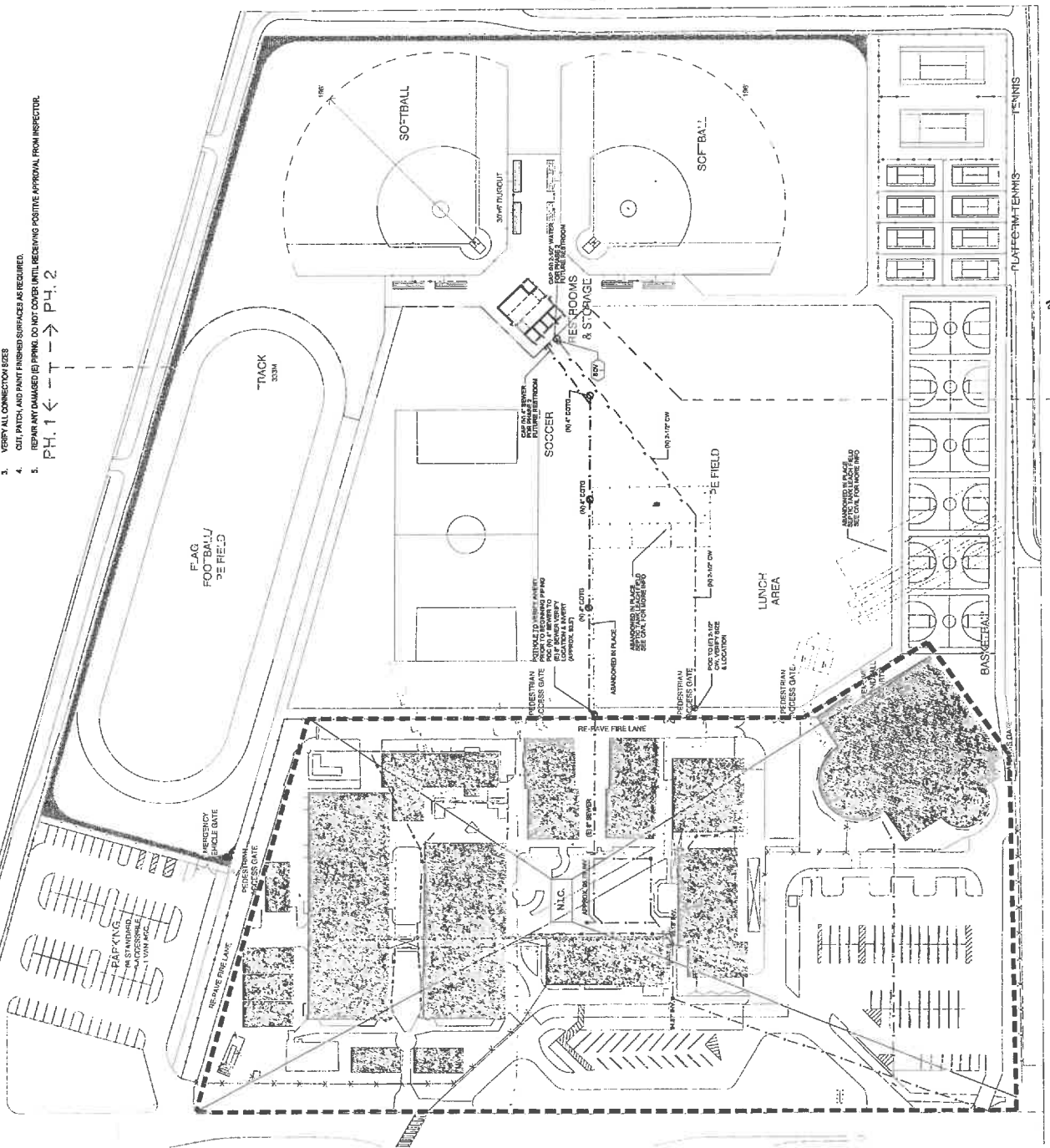



KRUGER BENBEN ZIEMER
 ARCHITECTS INC. AIA
 1000 17TH AVENUE, SUITE 1000
 DENVER, CO 80202

TODD J. JENSEN, AIA
 PROJECT ARCHITECT

JEFFREY L. JENSEN, AIA
 PROJECT ARCHITECT

JEFFREY L. JENSEN, AIA
 PROJECT ARCHITECT

JEFFREY L. JENSEN, AIA
 PROJECT ARCHITECT

JEFFREY L. JENSEN, AIA
 PROJECT ARCHITECT

JEFFREY L. JENSEN, AIA
 PROJECT ARCHITECT

JEFFREY L. JENSEN, AIA
 PROJECT ARCHITECT

JEFFREY L. JENSEN, AIA
 PROJECT ARCHITECT

JEFFREY L. JENSEN, AIA
 PROJECT ARCHITECT

JEFFREY L. JENSEN, AIA
 PROJECT ARCHITECT

JEFFREY L. JENSEN, AIA
 PROJECT ARCHITECT

JEFFREY L. JENSEN, AIA
 PROJECT ARCHITECT

JEFFREY L. JENSEN, AIA
 PROJECT ARCHITECT

JEFFREY L. JENSEN, AIA
 PROJECT ARCHITECT

JEFFREY L. JENSEN, AIA
 PROJECT ARCHITECT

JEFFREY L. JENSEN, AIA
 PROJECT ARCHITECT

JEFFREY L. JENSEN, AIA
 PROJECT ARCHITECT

SHEET NOTES

1. VERIFY LOCATION OF ALL BUILDINGS AND IMPROVEMENTS ON ARCHITECTURAL AND CIVIL PLANS.
2. CONDUCT VISUAL SURVEYS AND INSPECTIONS OF ALL EXISTING UTILITIES TO BE RELOCATED OR INSTALLED.
3. CONDUCT VISUAL SURVEYS AND INSPECTIONS OF ALL EXISTING UTILITIES TO BE RELOCATED OR INSTALLED.
4. CONDUCT VISUAL SURVEYS AND INSPECTIONS OF ALL EXISTING UTILITIES TO BE RELOCATED OR INSTALLED.
5. CONDUCT VISUAL SURVEYS AND INSPECTIONS OF ALL EXISTING UTILITIES TO BE RELOCATED OR INSTALLED.
6. CONDUCT VISUAL SURVEYS AND INSPECTIONS OF ALL EXISTING UTILITIES TO BE RELOCATED OR INSTALLED.
7. CONDUCT VISUAL SURVEYS AND INSPECTIONS OF ALL EXISTING UTILITIES TO BE RELOCATED OR INSTALLED.
8. CONDUCT VISUAL SURVEYS AND INSPECTIONS OF ALL EXISTING UTILITIES TO BE RELOCATED OR INSTALLED.
9. CONDUCT VISUAL SURVEYS AND INSPECTIONS OF ALL EXISTING UTILITIES TO BE RELOCATED OR INSTALLED.
10. CONDUCT VISUAL SURVEYS AND INSPECTIONS OF ALL EXISTING UTILITIES TO BE RELOCATED OR INSTALLED.
11. CONDUCT VISUAL SURVEYS AND INSPECTIONS OF ALL EXISTING UTILITIES TO BE RELOCATED OR INSTALLED.
12. CONDUCT VISUAL SURVEYS AND INSPECTIONS OF ALL EXISTING UTILITIES TO BE RELOCATED OR INSTALLED.
13. CONDUCT VISUAL SURVEYS AND INSPECTIONS OF ALL EXISTING UTILITIES TO BE RELOCATED OR INSTALLED.
14. CONDUCT VISUAL SURVEYS AND INSPECTIONS OF ALL EXISTING UTILITIES TO BE RELOCATED OR INSTALLED.
15. CONDUCT VISUAL SURVEYS AND INSPECTIONS OF ALL EXISTING UTILITIES TO BE RELOCATED OR INSTALLED.
16. CONDUCT VISUAL SURVEYS AND INSPECTIONS OF ALL EXISTING UTILITIES TO BE RELOCATED OR INSTALLED.
17. CONDUCT VISUAL SURVEYS AND INSPECTIONS OF ALL EXISTING UTILITIES TO BE RELOCATED OR INSTALLED.
18. CONDUCT VISUAL SURVEYS AND INSPECTIONS OF ALL EXISTING UTILITIES TO BE RELOCATED OR INSTALLED.
19. CONDUCT VISUAL SURVEYS AND INSPECTIONS OF ALL EXISTING UTILITIES TO BE RELOCATED OR INSTALLED.
20. CONDUCT VISUAL SURVEYS AND INSPECTIONS OF ALL EXISTING UTILITIES TO BE RELOCATED OR INSTALLED.

E NOTES

1. VERIFY LOCATION OF ALL BUILDINGS AND IMPROVEMENTS ON ARCHITECTURAL AND CIVIL PLANS.
2. CONDUCT VISUAL SURVEYS AND INSPECTIONS OF ALL EXISTING UTILITIES TO BE RELOCATED OR INSTALLED.
3. CONDUCT VISUAL SURVEYS AND INSPECTIONS OF ALL EXISTING UTILITIES TO BE RELOCATED OR INSTALLED.
4. CONDUCT VISUAL SURVEYS AND INSPECTIONS OF ALL EXISTING UTILITIES TO BE RELOCATED OR INSTALLED.
5. CONDUCT VISUAL SURVEYS AND INSPECTIONS OF ALL EXISTING UTILITIES TO BE RELOCATED OR INSTALLED.
6. CONDUCT VISUAL SURVEYS AND INSPECTIONS OF ALL EXISTING UTILITIES TO BE RELOCATED OR INSTALLED.
7. CONDUCT VISUAL SURVEYS AND INSPECTIONS OF ALL EXISTING UTILITIES TO BE RELOCATED OR INSTALLED.
8. CONDUCT VISUAL SURVEYS AND INSPECTIONS OF ALL EXISTING UTILITIES TO BE RELOCATED OR INSTALLED.
9. CONDUCT VISUAL SURVEYS AND INSPECTIONS OF ALL EXISTING UTILITIES TO BE RELOCATED OR INSTALLED.
10. CONDUCT VISUAL SURVEYS AND INSPECTIONS OF ALL EXISTING UTILITIES TO BE RELOCATED OR INSTALLED.
11. CONDUCT VISUAL SURVEYS AND INSPECTIONS OF ALL EXISTING UTILITIES TO BE RELOCATED OR INSTALLED.
12. CONDUCT VISUAL SURVEYS AND INSPECTIONS OF ALL EXISTING UTILITIES TO BE RELOCATED OR INSTALLED.
13. CONDUCT VISUAL SURVEYS AND INSPECTIONS OF ALL EXISTING UTILITIES TO BE RELOCATED OR INSTALLED.
14. CONDUCT VISUAL SURVEYS AND INSPECTIONS OF ALL EXISTING UTILITIES TO BE RELOCATED OR INSTALLED.
15. CONDUCT VISUAL SURVEYS AND INSPECTIONS OF ALL EXISTING UTILITIES TO BE RELOCATED OR INSTALLED.
16. CONDUCT VISUAL SURVEYS AND INSPECTIONS OF ALL EXISTING UTILITIES TO BE RELOCATED OR INSTALLED.
17. CONDUCT VISUAL SURVEYS AND INSPECTIONS OF ALL EXISTING UTILITIES TO BE RELOCATED OR INSTALLED.
18. CONDUCT VISUAL SURVEYS AND INSPECTIONS OF ALL EXISTING UTILITIES TO BE RELOCATED OR INSTALLED.
19. CONDUCT VISUAL SURVEYS AND INSPECTIONS OF ALL EXISTING UTILITIES TO BE RELOCATED OR INSTALLED.
20. CONDUCT VISUAL SURVEYS AND INSPECTIONS OF ALL EXISTING UTILITIES TO BE RELOCATED OR INSTALLED.

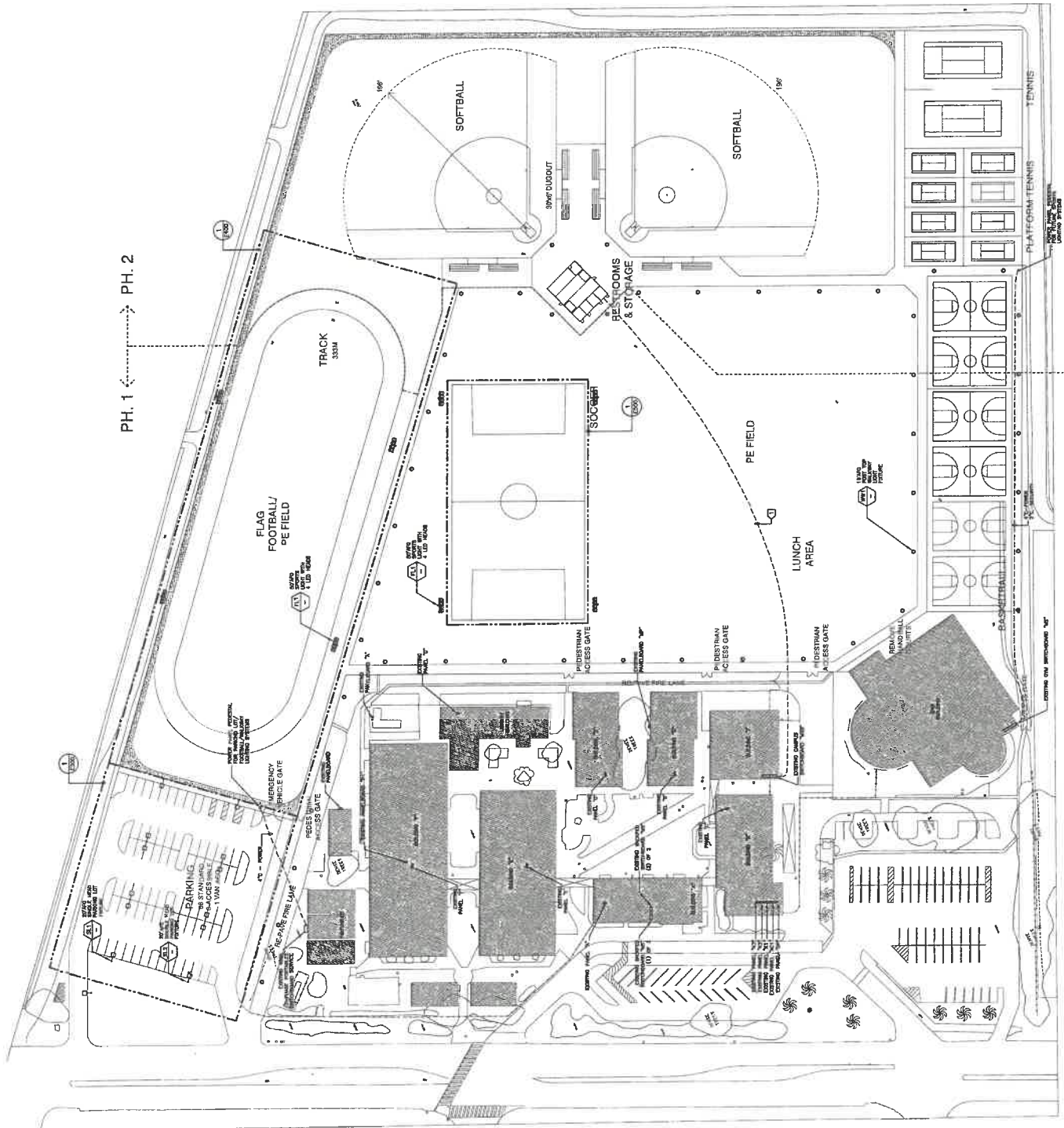

1 SITE POWER PLAN
 SCALE: 1" = 40' - 0"



CREATED ON: 11/14/2014
 DATE PLOTTED: 11/14/2014
 PLOT SCALE: 1" = 40' - 0"

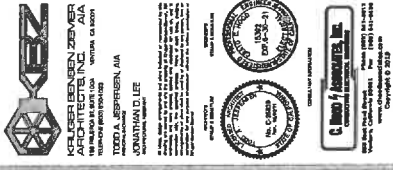

C. Reed & Associates, Inc.
Electrical Engineering
1000 North Main Street, Suite 100
Dana Point, CA 92629
Tel: (949) 261-1000
Fax: (949) 261-1001
www.creedandassociates.com

DATE: 11/15/19
JOB NO: 19024
JOB NAME: SPORTS FIELDS
TITLE: ELECTRICAL ENGINEER

E-201-A1

FEEDER SCHEDULE		
TAG	COMMENTS/CONNECTION	FROM
1	EXISTING FEEDER IN PANEL	-
2	-	-
3	-	-
4	-	-
5	-	-
6	-	-
7	-	-
8	-	-
9	-	-
10	-	-
11	-	-
12	-	-
13	-	-
14	-	-
15	-	-
16	-	-
17	-	-
18	-	-
19	-	-
20	-	-

- ### SHEET NOTES
- SCALE: 1"=8'-0" UNLESS OTHERWISE NOTED.
 - CONTRACTOR SHALL VERIFY ALL INFORMATION IN ARCHITECTURAL AND OTHER RECORDS AND FIELD SURVEY FOR ACCURACY AND COMPLETENESS OF ALL ELECTRICAL SYMBOLS AND NOTATIONS.
 - CONTRACTOR SHALL BE RESPONSIBLE FOR VERIFYING ALL ELECTRICAL SYMBOLS AND NOTATIONS ON ALL DRAWINGS AND FIELD SURVEY FOR ACCURACY AND COMPLETENESS OF ALL ELECTRICAL SYMBOLS AND NOTATIONS.
 - CONTRACTOR SHALL BE RESPONSIBLE FOR VERIFYING ALL ELECTRICAL SYMBOLS AND NOTATIONS ON ALL DRAWINGS AND FIELD SURVEY FOR ACCURACY AND COMPLETENESS OF ALL ELECTRICAL SYMBOLS AND NOTATIONS.
 - CONTRACTOR SHALL BE RESPONSIBLE FOR VERIFYING ALL ELECTRICAL SYMBOLS AND NOTATIONS ON ALL DRAWINGS AND FIELD SURVEY FOR ACCURACY AND COMPLETENESS OF ALL ELECTRICAL SYMBOLS AND NOTATIONS.
 - CONTRACTOR SHALL BE RESPONSIBLE FOR VERIFYING ALL ELECTRICAL SYMBOLS AND NOTATIONS ON ALL DRAWINGS AND FIELD SURVEY FOR ACCURACY AND COMPLETENESS OF ALL ELECTRICAL SYMBOLS AND NOTATIONS.
 - CONTRACTOR SHALL BE RESPONSIBLE FOR VERIFYING ALL ELECTRICAL SYMBOLS AND NOTATIONS ON ALL DRAWINGS AND FIELD SURVEY FOR ACCURACY AND COMPLETENESS OF ALL ELECTRICAL SYMBOLS AND NOTATIONS.
 - CONTRACTOR SHALL BE RESPONSIBLE FOR VERIFYING ALL ELECTRICAL SYMBOLS AND NOTATIONS ON ALL DRAWINGS AND FIELD SURVEY FOR ACCURACY AND COMPLETENESS OF ALL ELECTRICAL SYMBOLS AND NOTATIONS.
 - CONTRACTOR SHALL BE RESPONSIBLE FOR VERIFYING ALL ELECTRICAL SYMBOLS AND NOTATIONS ON ALL DRAWINGS AND FIELD SURVEY FOR ACCURACY AND COMPLETENESS OF ALL ELECTRICAL SYMBOLS AND NOTATIONS.
 - CONTRACTOR SHALL BE RESPONSIBLE FOR VERIFYING ALL ELECTRICAL SYMBOLS AND NOTATIONS ON ALL DRAWINGS AND FIELD SURVEY FOR ACCURACY AND COMPLETENESS OF ALL ELECTRICAL SYMBOLS AND NOTATIONS.
 - CONTRACTOR SHALL BE RESPONSIBLE FOR VERIFYING ALL ELECTRICAL SYMBOLS AND NOTATIONS ON ALL DRAWINGS AND FIELD SURVEY FOR ACCURACY AND COMPLETENESS OF ALL ELECTRICAL SYMBOLS AND NOTATIONS.
 - CONTRACTOR SHALL BE RESPONSIBLE FOR VERIFYING ALL ELECTRICAL SYMBOLS AND NOTATIONS ON ALL DRAWINGS AND FIELD SURVEY FOR ACCURACY AND COMPLETENESS OF ALL ELECTRICAL SYMBOLS AND NOTATIONS.
 - CONTRACTOR SHALL BE RESPONSIBLE FOR VERIFYING ALL ELECTRICAL SYMBOLS AND NOTATIONS ON ALL DRAWINGS AND FIELD SURVEY FOR ACCURACY AND COMPLETENESS OF ALL ELECTRICAL SYMBOLS AND NOTATIONS.
 - CONTRACTOR SHALL BE RESPONSIBLE FOR VERIFYING ALL ELECTRICAL SYMBOLS AND NOTATIONS ON ALL DRAWINGS AND FIELD SURVEY FOR ACCURACY AND COMPLETENESS OF ALL ELECTRICAL SYMBOLS AND NOTATIONS.
 - CONTRACTOR SHALL BE RESPONSIBLE FOR VERIFYING ALL ELECTRICAL SYMBOLS AND NOTATIONS ON ALL DRAWINGS AND FIELD SURVEY FOR ACCURACY AND COMPLETENESS OF ALL ELECTRICAL SYMBOLS AND NOTATIONS.

MSB LOAD SUMMARY

DESCRIPTION	LOAD	REMARKS
EXISTING 100% PANEL EXHIBIT 100% PANEL PER CEC REQUIREMENTS	98 KVA	
PANEL "N1" PANEL	48 KVA	
PANES "N1", "N2" & "N3"	117 KVA	
PANEL "N4"	24 KVA	
TOTAL ON MSB (100% PANELS AT 200% LOAD)	207 KVA	

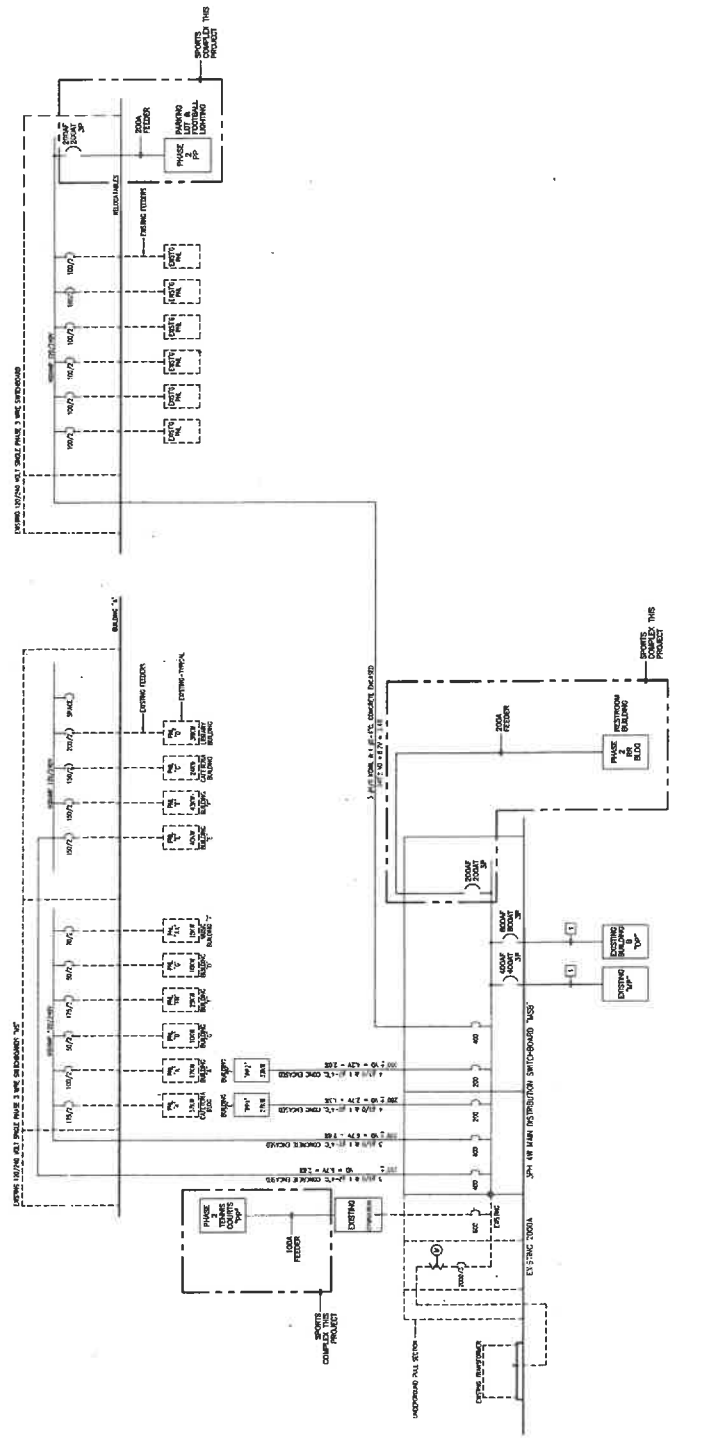
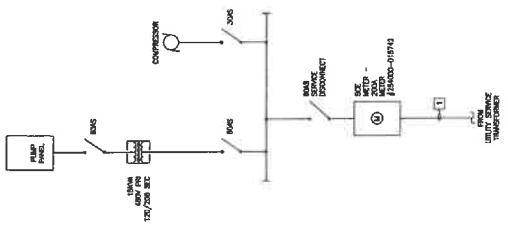

- SHEET NOTES**
1. VERIFY LOCATION OF ALL BUILDING AND IMPROVEMENTS ON EXISTING RECORD DRAWINGS & RECORDS OF ALL ELECTRICAL WORK TO BE INSTALLED IN INSTALLATION.
 2. VERIFY ALL WORK IS IN ACCORDANCE WITH ALL CITY ORDINANCES AND ALL APPLICABLE NATIONAL ELECTRICAL CODES AND STANDARDS AND ALL APPLICABLE STATE AND FEDERAL LAWS AND REGULATIONS.
 3. VERIFY ALL ELECTRICAL WORK IS IN ACCORDANCE WITH THE LATEST EDITIONS OF THE NATIONAL ELECTRICAL CODE AND THE NATIONAL FIRE ALARMS CODE.
 4. VERIFY ALL ELECTRICAL WORK IS IN ACCORDANCE WITH THE LATEST EDITIONS OF THE NATIONAL ELECTRICAL CODE AND THE NATIONAL FIRE ALARMS CODE.
 5. VERIFY ALL ELECTRICAL WORK IS IN ACCORDANCE WITH THE LATEST EDITIONS OF THE NATIONAL ELECTRICAL CODE AND THE NATIONAL FIRE ALARMS CODE.
 6. VERIFY ALL ELECTRICAL WORK IS IN ACCORDANCE WITH THE LATEST EDITIONS OF THE NATIONAL ELECTRICAL CODE AND THE NATIONAL FIRE ALARMS CODE.
 7. VERIFY ALL ELECTRICAL WORK IS IN ACCORDANCE WITH THE LATEST EDITIONS OF THE NATIONAL ELECTRICAL CODE AND THE NATIONAL FIRE ALARMS CODE.
 8. VERIFY ALL ELECTRICAL WORK IS IN ACCORDANCE WITH THE LATEST EDITIONS OF THE NATIONAL ELECTRICAL CODE AND THE NATIONAL FIRE ALARMS CODE.
 9. VERIFY ALL ELECTRICAL WORK IS IN ACCORDANCE WITH THE LATEST EDITIONS OF THE NATIONAL ELECTRICAL CODE AND THE NATIONAL FIRE ALARMS CODE.
 10. VERIFY ALL ELECTRICAL WORK IS IN ACCORDANCE WITH THE LATEST EDITIONS OF THE NATIONAL ELECTRICAL CODE AND THE NATIONAL FIRE ALARMS CODE.
 11. VERIFY ALL ELECTRICAL WORK IS IN ACCORDANCE WITH THE LATEST EDITIONS OF THE NATIONAL ELECTRICAL CODE AND THE NATIONAL FIRE ALARMS CODE.
 12. VERIFY ALL ELECTRICAL WORK IS IN ACCORDANCE WITH THE LATEST EDITIONS OF THE NATIONAL ELECTRICAL CODE AND THE NATIONAL FIRE ALARMS CODE.
 13. VERIFY ALL ELECTRICAL WORK IS IN ACCORDANCE WITH THE LATEST EDITIONS OF THE NATIONAL ELECTRICAL CODE AND THE NATIONAL FIRE ALARMS CODE.
 14. VERIFY ALL ELECTRICAL WORK IS IN ACCORDANCE WITH THE LATEST EDITIONS OF THE NATIONAL ELECTRICAL CODE AND THE NATIONAL FIRE ALARMS CODE.
 15. VERIFY ALL ELECTRICAL WORK IS IN ACCORDANCE WITH THE LATEST EDITIONS OF THE NATIONAL ELECTRICAL CODE AND THE NATIONAL FIRE ALARMS CODE.
 16. VERIFY ALL ELECTRICAL WORK IS IN ACCORDANCE WITH THE LATEST EDITIONS OF THE NATIONAL ELECTRICAL CODE AND THE NATIONAL FIRE ALARMS CODE.
 17. VERIFY ALL ELECTRICAL WORK IS IN ACCORDANCE WITH THE LATEST EDITIONS OF THE NATIONAL ELECTRICAL CODE AND THE NATIONAL FIRE ALARMS CODE.
 18. VERIFY ALL ELECTRICAL WORK IS IN ACCORDANCE WITH THE LATEST EDITIONS OF THE NATIONAL ELECTRICAL CODE AND THE NATIONAL FIRE ALARMS CODE.
 19. VERIFY ALL ELECTRICAL WORK IS IN ACCORDANCE WITH THE LATEST EDITIONS OF THE NATIONAL ELECTRICAL CODE AND THE NATIONAL FIRE ALARMS CODE.
 20. VERIFY ALL ELECTRICAL WORK IS IN ACCORDANCE WITH THE LATEST EDITIONS OF THE NATIONAL ELECTRICAL CODE AND THE NATIONAL FIRE ALARMS CODE.

E NOTES

1. VERIFY LOCATION OF ALL BUILDING AND IMPROVEMENTS ON EXISTING RECORD DRAWINGS & RECORDS OF ALL ELECTRICAL WORK TO BE INSTALLED IN INSTALLATION.
2. VERIFY ALL WORK IS IN ACCORDANCE WITH ALL CITY ORDINANCES AND ALL APPLICABLE NATIONAL ELECTRICAL CODES AND STANDARDS AND ALL APPLICABLE STATE AND FEDERAL LAWS AND REGULATIONS.
3. VERIFY ALL ELECTRICAL WORK IS IN ACCORDANCE WITH THE LATEST EDITIONS OF THE NATIONAL ELECTRICAL CODE AND THE NATIONAL FIRE ALARMS CODE.
4. VERIFY ALL ELECTRICAL WORK IS IN ACCORDANCE WITH THE LATEST EDITIONS OF THE NATIONAL ELECTRICAL CODE AND THE NATIONAL FIRE ALARMS CODE.
5. VERIFY ALL ELECTRICAL WORK IS IN ACCORDANCE WITH THE LATEST EDITIONS OF THE NATIONAL ELECTRICAL CODE AND THE NATIONAL FIRE ALARMS CODE.
6. VERIFY ALL ELECTRICAL WORK IS IN ACCORDANCE WITH THE LATEST EDITIONS OF THE NATIONAL ELECTRICAL CODE AND THE NATIONAL FIRE ALARMS CODE.
7. VERIFY ALL ELECTRICAL WORK IS IN ACCORDANCE WITH THE LATEST EDITIONS OF THE NATIONAL ELECTRICAL CODE AND THE NATIONAL FIRE ALARMS CODE.
8. VERIFY ALL ELECTRICAL WORK IS IN ACCORDANCE WITH THE LATEST EDITIONS OF THE NATIONAL ELECTRICAL CODE AND THE NATIONAL FIRE ALARMS CODE.
9. VERIFY ALL ELECTRICAL WORK IS IN ACCORDANCE WITH THE LATEST EDITIONS OF THE NATIONAL ELECTRICAL CODE AND THE NATIONAL FIRE ALARMS CODE.
10. VERIFY ALL ELECTRICAL WORK IS IN ACCORDANCE WITH THE LATEST EDITIONS OF THE NATIONAL ELECTRICAL CODE AND THE NATIONAL FIRE ALARMS CODE.
11. VERIFY ALL ELECTRICAL WORK IS IN ACCORDANCE WITH THE LATEST EDITIONS OF THE NATIONAL ELECTRICAL CODE AND THE NATIONAL FIRE ALARMS CODE.
12. VERIFY ALL ELECTRICAL WORK IS IN ACCORDANCE WITH THE LATEST EDITIONS OF THE NATIONAL ELECTRICAL CODE AND THE NATIONAL FIRE ALARMS CODE.
13. VERIFY ALL ELECTRICAL WORK IS IN ACCORDANCE WITH THE LATEST EDITIONS OF THE NATIONAL ELECTRICAL CODE AND THE NATIONAL FIRE ALARMS CODE.
14. VERIFY ALL ELECTRICAL WORK IS IN ACCORDANCE WITH THE LATEST EDITIONS OF THE NATIONAL ELECTRICAL CODE AND THE NATIONAL FIRE ALARMS CODE.
15. VERIFY ALL ELECTRICAL WORK IS IN ACCORDANCE WITH THE LATEST EDITIONS OF THE NATIONAL ELECTRICAL CODE AND THE NATIONAL FIRE ALARMS CODE.
16. VERIFY ALL ELECTRICAL WORK IS IN ACCORDANCE WITH THE LATEST EDITIONS OF THE NATIONAL ELECTRICAL CODE AND THE NATIONAL FIRE ALARMS CODE.
17. VERIFY ALL ELECTRICAL WORK IS IN ACCORDANCE WITH THE LATEST EDITIONS OF THE NATIONAL ELECTRICAL CODE AND THE NATIONAL FIRE ALARMS CODE.
18. VERIFY ALL ELECTRICAL WORK IS IN ACCORDANCE WITH THE LATEST EDITIONS OF THE NATIONAL ELECTRICAL CODE AND THE NATIONAL FIRE ALARMS CODE.
19. VERIFY ALL ELECTRICAL WORK IS IN ACCORDANCE WITH THE LATEST EDITIONS OF THE NATIONAL ELECTRICAL CODE AND THE NATIONAL FIRE ALARMS CODE.
20. VERIFY ALL ELECTRICAL WORK IS IN ACCORDANCE WITH THE LATEST EDITIONS OF THE NATIONAL ELECTRICAL CODE AND THE NATIONAL FIRE ALARMS CODE.

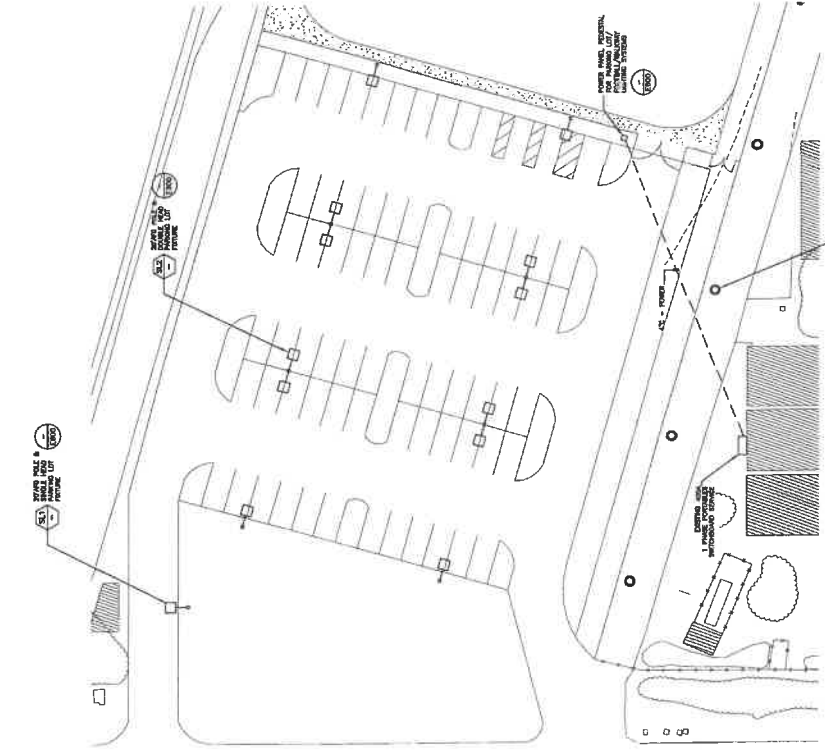

1 PARKING LOT LIGHTING PLAN
SCALE: 1" = 20' - 0"

RIO SCHOOL DISTRICT
3100 NORTH ROSE AVENUE, DENVER, CO 80209
SPORTS FIELDS COMPLEX - PHASE 1

VOELKER BERNER ZENNER ARCHITECTS AND ENGINEERS
3100 NORTH ROSE AVENUE, DENVER, CO 80209
TODD J. BERGER, P.E.
DENVER, CO 80209
DATE: 08/15/2018
PROJECT: SPORTS FIELDS COMPLEX - PHASE 1

G. Davis & Associates, Inc.
10000 E. HIGHWAY 103, SUITE 200
DENVER, CO 80231
DATE: 08/15/2018
PROJECT: SPORTS FIELDS COMPLEX - PHASE 1

NO.	REVISION	DATE
1	ISSUE FOR PERMIT	08/15/2018
2	ISSUE FOR PERMIT	08/15/2018
3	ISSUE FOR PERMIT	08/15/2018
4	ISSUE FOR PERMIT	08/15/2018
5	ISSUE FOR PERMIT	08/15/2018
6	ISSUE FOR PERMIT	08/15/2018
7	ISSUE FOR PERMIT	08/15/2018
8	ISSUE FOR PERMIT	08/15/2018
9	ISSUE FOR PERMIT	08/15/2018
10	ISSUE FOR PERMIT	08/15/2018



E-300-A1

DESIGN DEVELOPMENT

KRUGER-BENSEN ZOVNER ARCHITECTS INC. ARCHITECTS
 1410 W. NORTH AVENUE SUITE 200 CHANDLER, CA 95004
 TODD A. JEFFERSON, AIA
 JONATHAN D. LEE

TODD A. JEFFERSON, AIA
 No. 40223
 State of California
 PROFESSIONAL ENGINEER

JONATHAN D. LEE
 No. 40223
 State of California
 PROFESSIONAL ENGINEER

NO.	REVISION DESCRIPTION	DATE
1	ISSUED FOR PERMIT	10/27/11
2	FOR CONSTRUCTION	11/15/11
3	FOR PERMIT	12/01/11
4	FOR PERMIT	01/18/12
5	FOR PERMIT	02/20/12
6	FOR PERMIT	03/22/12
7	FOR PERMIT	04/24/12
8	FOR PERMIT	05/26/12
9	FOR PERMIT	06/28/12
10	FOR PERMIT	07/30/12
11	FOR PERMIT	08/31/12
12	FOR PERMIT	09/30/12
13	FOR PERMIT	10/31/12
14	FOR PERMIT	11/30/12
15	FOR PERMIT	12/31/12
16	FOR PERMIT	01/31/13
17	FOR PERMIT	02/28/13
18	FOR PERMIT	03/29/13
19	FOR PERMIT	04/30/13
20	FOR PERMIT	05/31/13
21	FOR PERMIT	06/30/13
22	FOR PERMIT	07/31/13
23	FOR PERMIT	08/31/13
24	FOR PERMIT	09/30/13
25	FOR PERMIT	10/31/13
26	FOR PERMIT	11/30/13
27	FOR PERMIT	12/31/13
28	FOR PERMIT	01/31/14
29	FOR PERMIT	02/28/14
30	FOR PERMIT	03/29/14
31	FOR PERMIT	04/30/14
32	FOR PERMIT	05/31/14
33	FOR PERMIT	06/30/14
34	FOR PERMIT	07/31/14
35	FOR PERMIT	08/31/14
36	FOR PERMIT	09/30/14
37	FOR PERMIT	10/31/14
38	FOR PERMIT	11/30/14
39	FOR PERMIT	12/31/14
40	FOR PERMIT	01/31/15
41	FOR PERMIT	02/28/15
42	FOR PERMIT	03/29/15
43	FOR PERMIT	04/30/15
44	FOR PERMIT	05/31/15
45	FOR PERMIT	06/30/15
46	FOR PERMIT	07/31/15
47	FOR PERMIT	08/31/15
48	FOR PERMIT	09/30/15
49	FOR PERMIT	10/31/15
50	FOR PERMIT	11/30/15
51	FOR PERMIT	12/31/15
52	FOR PERMIT	01/31/16
53	FOR PERMIT	02/28/16
54	FOR PERMIT	03/29/16
55	FOR PERMIT	04/30/16
56	FOR PERMIT	05/31/16
57	FOR PERMIT	06/30/16
58	FOR PERMIT	07/31/16
59	FOR PERMIT	08/31/16
60	FOR PERMIT	09/30/16
61	FOR PERMIT	10/31/16
62	FOR PERMIT	11/30/16
63	FOR PERMIT	12/31/16
64	FOR PERMIT	01/31/17
65	FOR PERMIT	02/28/17
66	FOR PERMIT	03/29/17
67	FOR PERMIT	04/30/17
68	FOR PERMIT	05/31/17
69	FOR PERMIT	06/30/17
70	FOR PERMIT	07/31/17
71	FOR PERMIT	08/31/17
72	FOR PERMIT	09/30/17
73	FOR PERMIT	10/31/17
74	FOR PERMIT	11/30/17
75	FOR PERMIT	12/31/17
76	FOR PERMIT	01/31/18
77	FOR PERMIT	02/28/18
78	FOR PERMIT	03/29/18
79	FOR PERMIT	04/30/18
80	FOR PERMIT	05/31/18
81	FOR PERMIT	06/30/18
82	FOR PERMIT	07/31/18
83	FOR PERMIT	08/31/18
84	FOR PERMIT	09/30/18
85	FOR PERMIT	10/31/18
86	FOR PERMIT	11/30/18
87	FOR PERMIT	12/31/18
88	FOR PERMIT	01/31/19
89	FOR PERMIT	02/28/19
90	FOR PERMIT	03/29/19
91	FOR PERMIT	04/30/19
92	FOR PERMIT	05/31/19
93	FOR PERMIT	06/30/19
94	FOR PERMIT	07/31/19
95	FOR PERMIT	08/31/19
96	FOR PERMIT	09/30/19
97	FOR PERMIT	10/31/19
98	FOR PERMIT	11/30/19
99	FOR PERMIT	12/31/19
100	FOR PERMIT	01/31/20

SHEET NOTES

- VERIFY LOCATION OF ALL UTILITIES AND APPROPRIATE ON DRAWINGS.
- CONTRACTOR SHALL VERIFY LOCATION & DEPTH OF ALL UTILITIES PRIOR TO ANY EXCAVATION.
- CONTRACTOR SHALL VERIFY LOCATION & DEPTH OF ALL UTILITIES PRIOR TO ANY EXCAVATION.
- CONTRACTOR SHALL VERIFY LOCATION & DEPTH OF ALL UTILITIES PRIOR TO ANY EXCAVATION.
- FIELD VERIFY LOCATION OF ALL UNDERGROUND UTILITIES PRIOR TO ANY EXCAVATION.
- ALL EXCAVATION SHALL BE PROTECTED WITH APPROVED SHIELDING.
- CONTRACTOR SHALL PROTECT AND REPAIR ALL SET ELECTRICAL SERVICE REQUIREMENTS WITH SERVICE QUALITY.
- ALL WORK SHALL BE ACCORDING TO THE LATEST EDITION OF THE CALIFORNIA ELECTRICAL CODE (CEC) AND THE NATIONAL ELECTRICAL CODE (NEC).
- CONTRACTOR SHALL PROTECT AND REPAIR ALL SET ELECTRICAL SERVICE REQUIREMENTS WITH SERVICE QUALITY.
- ALL WORK SHALL BE ACCORDING TO THE LATEST EDITION OF THE CALIFORNIA ELECTRICAL CODE (CEC) AND THE NATIONAL ELECTRICAL CODE (NEC).
- CONTRACTOR SHALL PROTECT AND REPAIR ALL SET ELECTRICAL SERVICE REQUIREMENTS WITH SERVICE QUALITY.
- ALL WORK SHALL BE ACCORDING TO THE LATEST EDITION OF THE CALIFORNIA ELECTRICAL CODE (CEC) AND THE NATIONAL ELECTRICAL CODE (NEC).
- CONTRACTOR SHALL PROTECT AND REPAIR ALL SET ELECTRICAL SERVICE REQUIREMENTS WITH SERVICE QUALITY.
- ALL WORK SHALL BE ACCORDING TO THE LATEST EDITION OF THE CALIFORNIA ELECTRICAL CODE (CEC) AND THE NATIONAL ELECTRICAL CODE (NEC).
- CONTRACTOR SHALL PROTECT AND REPAIR ALL SET ELECTRICAL SERVICE REQUIREMENTS WITH SERVICE QUALITY.

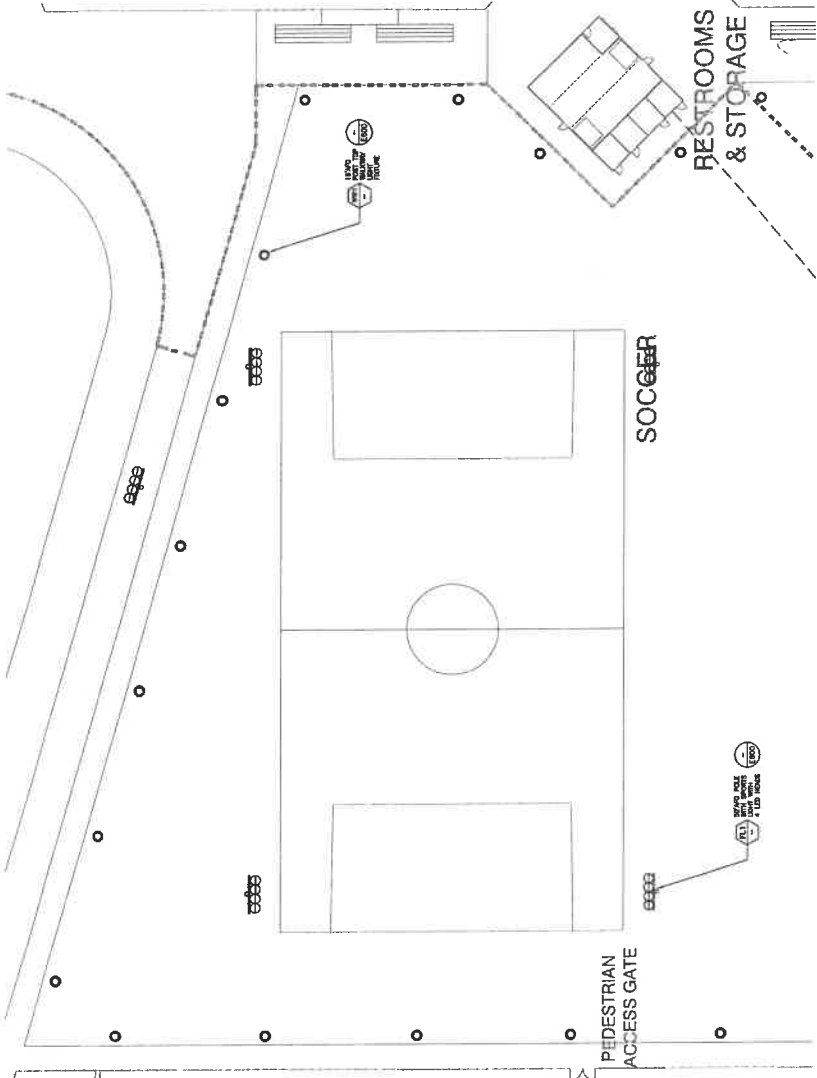

1 SOCCER LIGHTING PLAN
 SCALE: 1/8" = 10' - 0"



KLJLBERGENSEN ZIEVER ARCHITECTS, INC.
 10000 WILSON AVENUE, SUITE 100
 GARDENA, CA 90248
 TORO A. ESPERREN, AIA
 10000 WILSON AVENUE, SUITE 100
 GARDENA, CA 90248

LIGHTING FIXTURE SCHEDULE

TAG	FINISH	WATT	DESCRIPTION	LAMP TYPE AND QUANTITY	MOUNTING	MANUFACTURER AND MODEL NUMBER	REMARKS
71	□	148	DOUBLE HEAD PARKING LOT LIGHTING	LED 4000K	POLE MOUNTED	SEE AREA LUMINAIRE SCHEDULE FOR LED P2 4007 K3	
72	□	148	DOUBLE HEAD PARKING LOT LIGHTING	LED 4000K	POLE MOUNTED	SEE AREA LUMINAIRE SCHEDULE FOR LED P2 4007 K3	
73	□	148	DOUBLE HEAD PARKING LOT LIGHTING	LED 4000K	POLE MOUNTED	SEE AREA LUMINAIRE SCHEDULE FOR LED P2 4007 K3	
74	□	148	DOUBLE HEAD PARKING LOT LIGHTING	LED 4000K	POLE MOUNTED	SEE AREA LUMINAIRE SCHEDULE FOR LED P2 4007 K3	
75	□	148	DOUBLE HEAD PARKING LOT LIGHTING	LED 4000K	POLE MOUNTED	SEE AREA LUMINAIRE SCHEDULE FOR LED P2 4007 K3	
76	□	148	DOUBLE HEAD PARKING LOT LIGHTING	LED 4000K	POLE MOUNTED	SEE AREA LUMINAIRE SCHEDULE FOR LED P2 4007 K3	
77	□	148	DOUBLE HEAD PARKING LOT LIGHTING	LED 4000K	POLE MOUNTED	SEE AREA LUMINAIRE SCHEDULE FOR LED P2 4007 K3	
78	□	148	DOUBLE HEAD PARKING LOT LIGHTING	LED 4000K	POLE MOUNTED	SEE AREA LUMINAIRE SCHEDULE FOR LED P2 4007 K3	
79	□	148	DOUBLE HEAD PARKING LOT LIGHTING	LED 4000K	POLE MOUNTED	SEE AREA LUMINAIRE SCHEDULE FOR LED P2 4007 K3	
80	□	148	DOUBLE HEAD PARKING LOT LIGHTING	LED 4000K	POLE MOUNTED	SEE AREA LUMINAIRE SCHEDULE FOR LED P2 4007 K3	

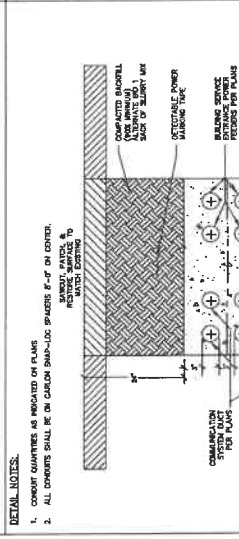
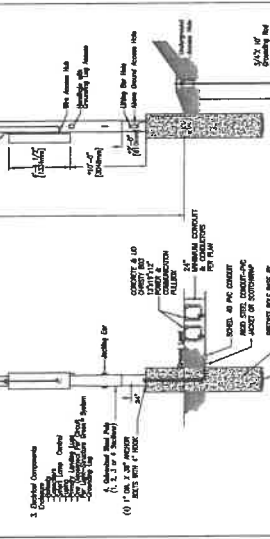
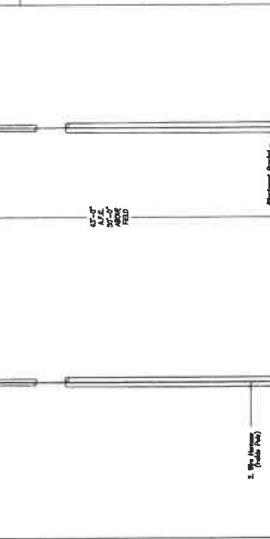
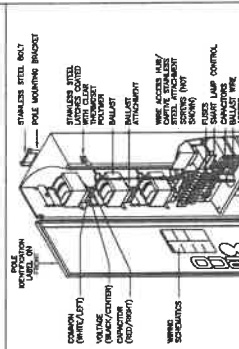
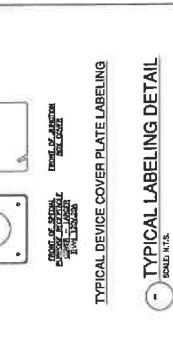
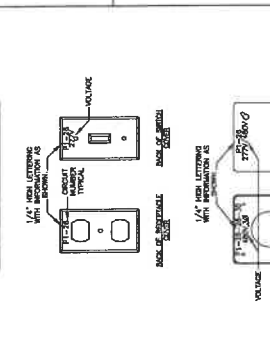
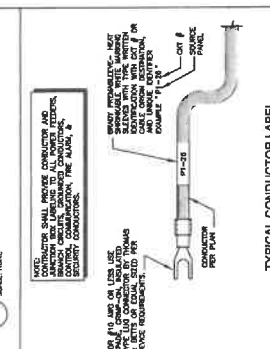
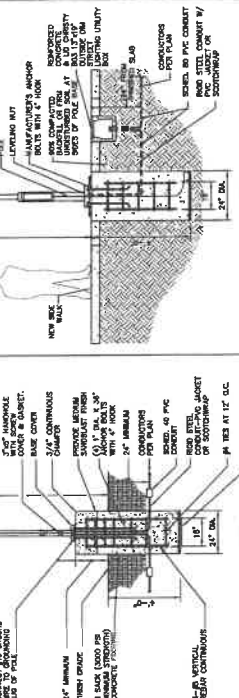
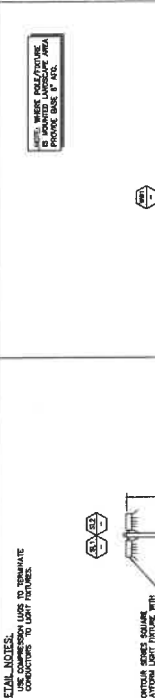
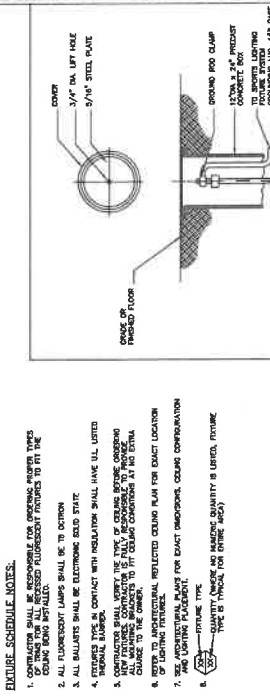

TITLE 24 OUTDOOR ENERGY COMPLIANCE FORMS

DATE OF CONSTRUCTION: 01/02/17
PROJECT NAME: CHAS JOOD

OWNER: C. JOOD & ASSOCIATES, INC.
1005 EAST FRONT STREET
VENTNURA, CA 93001
PHONE: (805)841-4012

DESIGNED BY: CHAS JOOD
1005 EAST FRONT STREET
VENTNURA, CA 93001
PHONE: (805)841-4012

PERMITTED BY: CHAS JOOD
1005 EAST FRONT STREET
VENTNURA, CA 93001
PHONE: (805)841-4012

C. JOOD & ASSOCIATES, INC. 1005 EAST FRONT STREET, VENTNURA, CA 93001

1. GENERAL INFORMATION:

Name of Applicant: CHAS JOOD
Address: 1005 EAST FRONT STREET, VENTNURA, CA 93001
City/State: VENTNURA, CA 93001
County: SAN BENITO
Project Name: CHAS JOOD
Date of Construction: 01/02/17
Permit No: 000841-4012

2. PROJECT LOCATION AND DESCRIPTION:

Location: 1005 EAST FRONT STREET, VENTNURA, CA 93001
Description: CHAS JOOD

DATE OF CONSTRUCTION: 01/02/17
PROJECT NAME: CHAS JOOD

OWNER: C. JOOD & ASSOCIATES, INC.
1005 EAST FRONT STREET
VENTNURA, CA 93001
PHONE: (805)841-4012

DESIGNED BY: CHAS JOOD
1005 EAST FRONT STREET
VENTNURA, CA 93001
PHONE: (805)841-4012

PERMITTED BY: CHAS JOOD
1005 EAST FRONT STREET
VENTNURA, CA 93001
PHONE: (805)841-4012

C. JOOD & ASSOCIATES, INC. 1005 EAST FRONT STREET, VENTNURA, CA 93001

1. GENERAL INFORMATION:

Name of Applicant: CHAS JOOD
Address: 1005 EAST FRONT STREET, VENTNURA, CA 93001
City/State: VENTNURA, CA 93001
County: SAN BENITO
Project Name: CHAS JOOD
Date of Construction: 01/02/17
Permit No: 000841-4012

2. PROJECT LOCATION AND DESCRIPTION:

Location: 1005 EAST FRONT STREET, VENTNURA, CA 93001
Description: CHAS JOOD

DATE OF CONSTRUCTION: 01/02/17
PROJECT NAME: CHAS JOOD

OWNER: C. JOOD & ASSOCIATES, INC.
1005 EAST FRONT STREET
VENTNURA, CA 93001
PHONE: (805)841-4012

DESIGNED BY: CHAS JOOD
1005 EAST FRONT STREET
VENTNURA, CA 93001
PHONE: (805)841-4012

PERMITTED BY: CHAS JOOD
1005 EAST FRONT STREET
VENTNURA, CA 93001
PHONE: (805)841-4012

C. JOOD & ASSOCIATES, INC. 1005 EAST FRONT STREET, VENTNURA, CA 93001

1. GENERAL INFORMATION:

Name of Applicant: CHAS JOOD
Address: 1005 EAST FRONT STREET, VENTNURA, CA 93001
City/State: VENTNURA, CA 93001
County: SAN BENITO
Project Name: CHAS JOOD
Date of Construction: 01/02/17
Permit No: 000841-4012

2. PROJECT LOCATION AND DESCRIPTION:

Location: 1005 EAST FRONT STREET, VENTNURA, CA 93001
Description: CHAS JOOD



APPROVALS:

DRAWN	DATE
CHECKED	DATE
REVIEWED	DATE
APPROVED	DATE

PROJECT INFORMATION:

PROJECT NAME: CHAS JOOD
ADDRESS: 1005 EAST FRONT STREET
CITY: VENTNURA, CA 93001
COUNTY: SAN BENITO
DATE OF CONSTRUCTION: 01/02/17
PERMIT NO: 000841-4012

PROJECT NO: E-701-A1



KRUGER BENSEN ZIEMER
 ARCHITECTS, INC. AIA
 1000 MARKET STREET, SUITE 200
 SAN FRANCISCO, CA 94102
 TEL: 415.774.1100
 WWW.KRUGERBENZENZIERER.COM
 JONATHAN D. LEE
 ARCHITECT, REGISTERED



JORDAN A. BANN
 LANDSCAPE ARCHITECTS, INC.
 459 NO. VENTURA AVE
 VENTURA CA 93001
 (805) 642-3841

DATE: 10/15/19
 DRAWN BY: PJ
 CHECKED BY: JAB
 REVISION DESCRIPTION
 DATE BY

SHEET: LANDSCAPE STAGING PLAN
 TITLE:

1:1

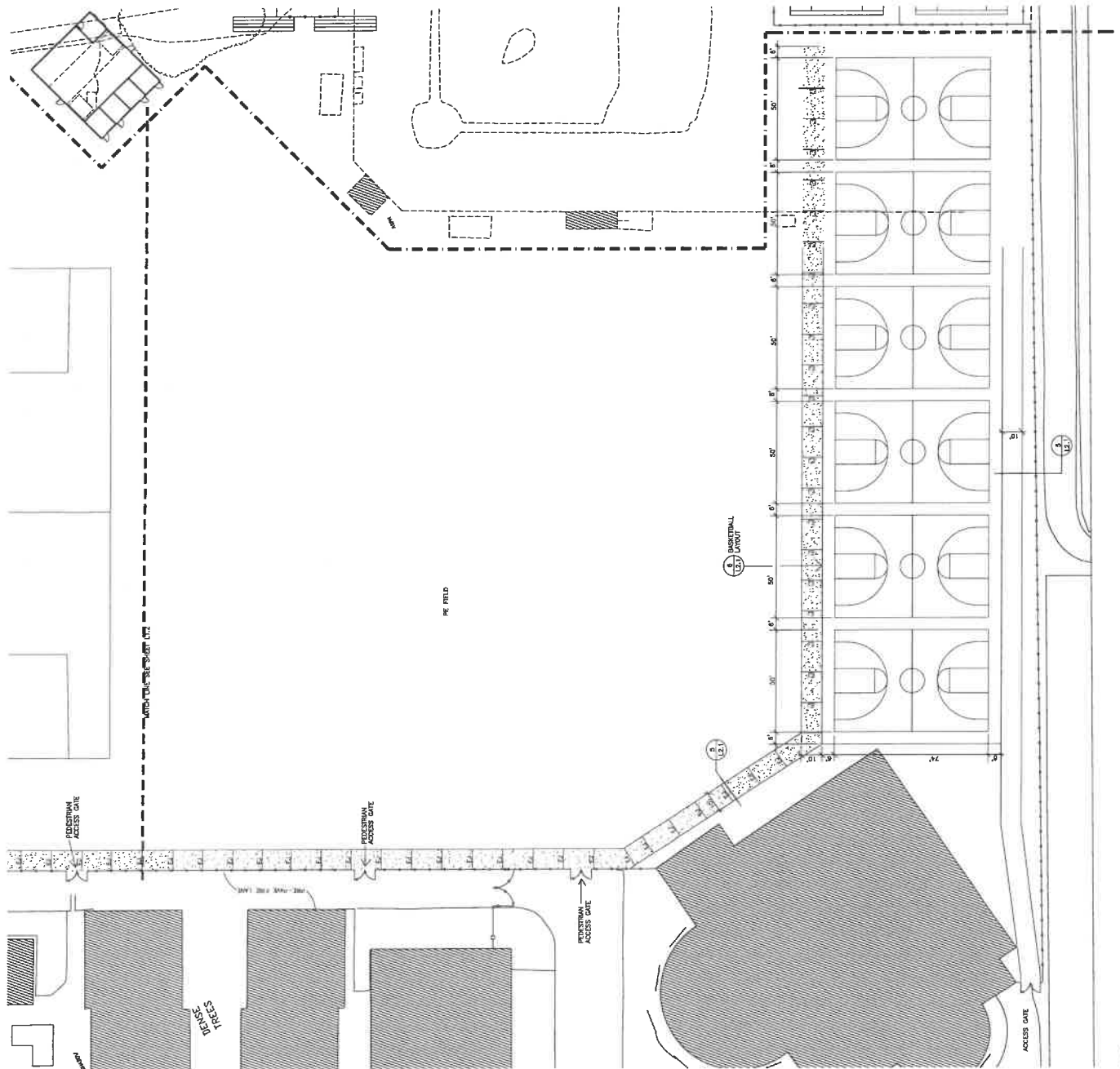
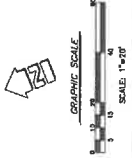

1:1 SCALE: 1" = 20'-0"



BRIGGS BENNETT ZELMER
 ARCHITECTS, INC. AIA
 1000 S. BAY STREET, SUITE 1000
 SAN FRANCISCO, CA 94109
 TEL: 415.774.3333
 WWW.BBZARCH.COM

PROJECT ARCHITECT: JORDAN, GILBERT & BAIN
 LANDSCAPE ARCHITECTS INC.
 1000 S. BAY STREET, SUITE 1000
 SAN FRANCISCO, CA 94109
 TEL: 415.774.3333
 WWW.JGBLANDSCAPE.COM



JORDAN, GILBERT & BAIN
 LANDSCAPE ARCHITECTS INC.
 1000 S. BAY STREET, SUITE 1000
 SAN FRANCISCO, CA 94109
 TEL: 415.774.3333
 WWW.JGBLANDSCAPE.COM

▲	PROPOSED PLANTING
▲	EXISTING PLANTING
▲	PROPOSED PAVEMENT
▲	EXISTING PAVEMENT
▲	PROPOSED CONCRETE
▲	EXISTING CONCRETE
▲	PROPOSED GRASS
▲	EXISTING GRASS
▲	PROPOSED DRIVEWAY
▲	EXISTING DRIVEWAY
▲	PROPOSED FENCE
▲	EXISTING FENCE
▲	PROPOSED SIGNAGE
▲	EXISTING SIGNAGE
▲	PROPOSED LIGHTING
▲	EXISTING LIGHTING
▲	PROPOSED UTILITY
▲	EXISTING UTILITY
▲	PROPOSED WATER
▲	EXISTING WATER
▲	PROPOSED SEWER
▲	EXISTING SEWER
▲	PROPOSED GAS
▲	EXISTING GAS
▲	PROPOSED ELEC
▲	EXISTING ELEC
▲	PROPOSED TEL
▲	EXISTING TEL
▲	PROPOSED CABLE
▲	EXISTING CABLE
▲	PROPOSED IR
▲	EXISTING IR
▲	PROPOSED TV
▲	EXISTING TV
▲	PROPOSED ANTENNA
▲	EXISTING ANTENNA
▲	PROPOSED OTHER
▲	EXISTING OTHER

DATE: 10/20/11
 DRAWN BY: JGB
 CHECKED BY: JGB
 PROJECT: LANDSCAPE STUDIO PLAN
 SHEET: L1.2

SCALE: 1" = 20'-0"

← PH. 1 PH. 2 →

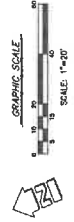
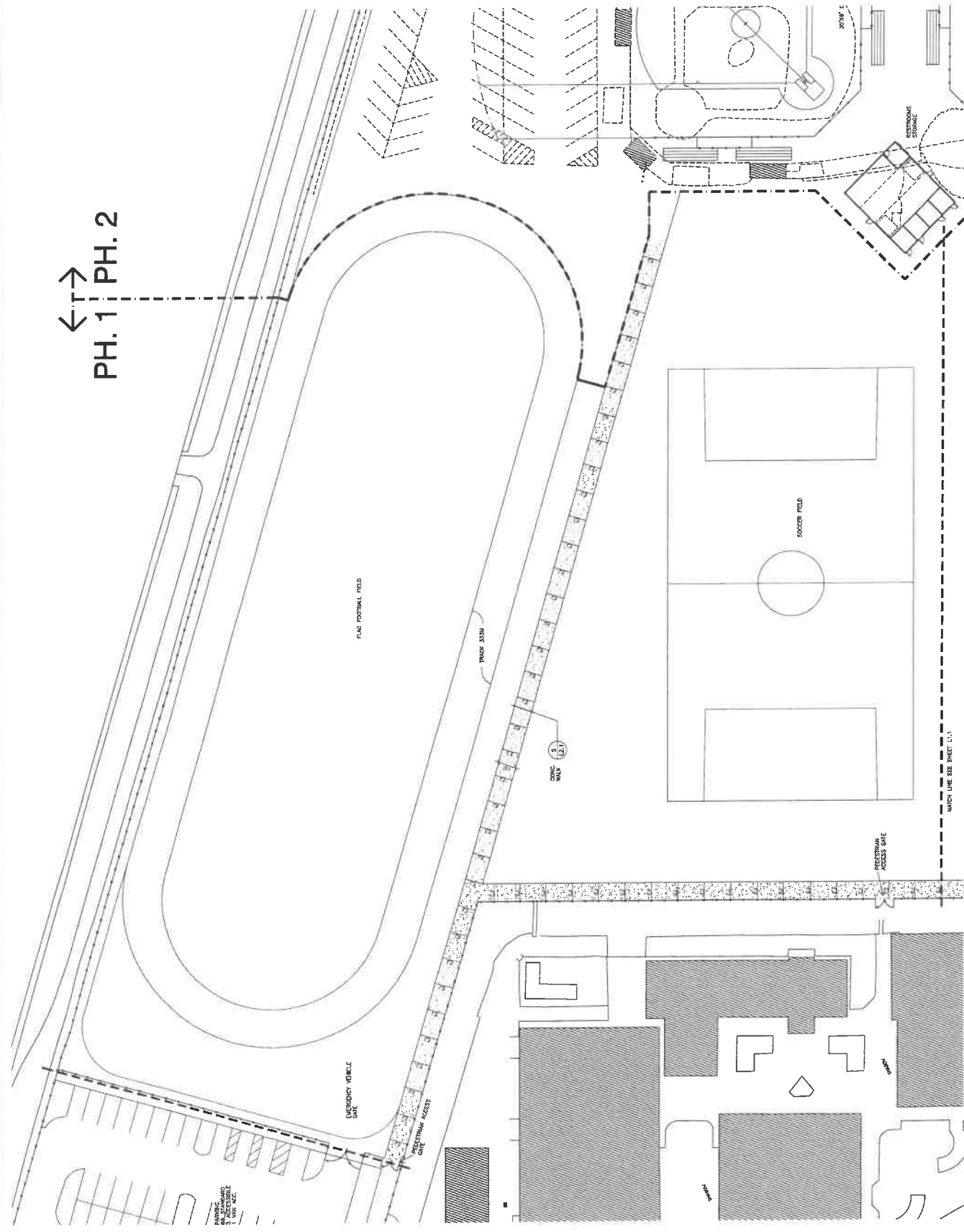

WATCH LINE SEE SHEET L1.1

SCALE: 1" = 20'-0"





KRUGER BENSEN ZIEMER
 1875 CALIFORNIA STREET, SUITE 100, SAN FRANCISCO, CALIFORNIA 94109
 TEL: 415.774.8800 FAX: 415.774.8801
 WWW.KRUGERBENZENZIER.COM
 AIA
 JONATHAN D. LEE
 LICENSED LANDSCAPE ARCHITECT
 No. 10000
 STATE OF CALIFORNIA
 EXPIRES 12/31/2011

DATE: 10/15/10
 DRAWN BY: J. BAY
 CHECKED BY: J. BAY
 PROJECT: RIO DEL VALLE MIDDLE SCHOOL
 SHEET: L1.3



JORDAN BAY
 LANDSCAPE ARCHITECTS INC.
 458 NO. VENTURA AVE.
 VENTURA CA 93001
 (805) 842-3841

DATE: 10/15/10
 DRAWN BY: J. BAY
 CHECKED BY: J. BAY
 PROJECT: RIO DEL VALLE MIDDLE SCHOOL
 SHEET: L1.3

DATE: 10/15/10
 DRAWN BY: J. BAY
 CHECKED BY: J. BAY
 PROJECT: RIO DEL VALLE MIDDLE SCHOOL
 SHEET: L1.3

DATE: 10/15/10
 DRAWN BY: J. BAY
 CHECKED BY: J. BAY
 PROJECT: RIO DEL VALLE MIDDLE SCHOOL
 SHEET: L1.3

DATE: 10/15/10
 DRAWN BY: J. BAY
 CHECKED BY: J. BAY
 PROJECT: RIO DEL VALLE MIDDLE SCHOOL
 SHEET: L1.3

DATE: 10/15/10
 DRAWN BY: J. BAY
 CHECKED BY: J. BAY
 PROJECT: RIO DEL VALLE MIDDLE SCHOOL
 SHEET: L1.3

DATE: 10/15/10
 DRAWN BY: J. BAY
 CHECKED BY: J. BAY
 PROJECT: RIO DEL VALLE MIDDLE SCHOOL
 SHEET: L1.3

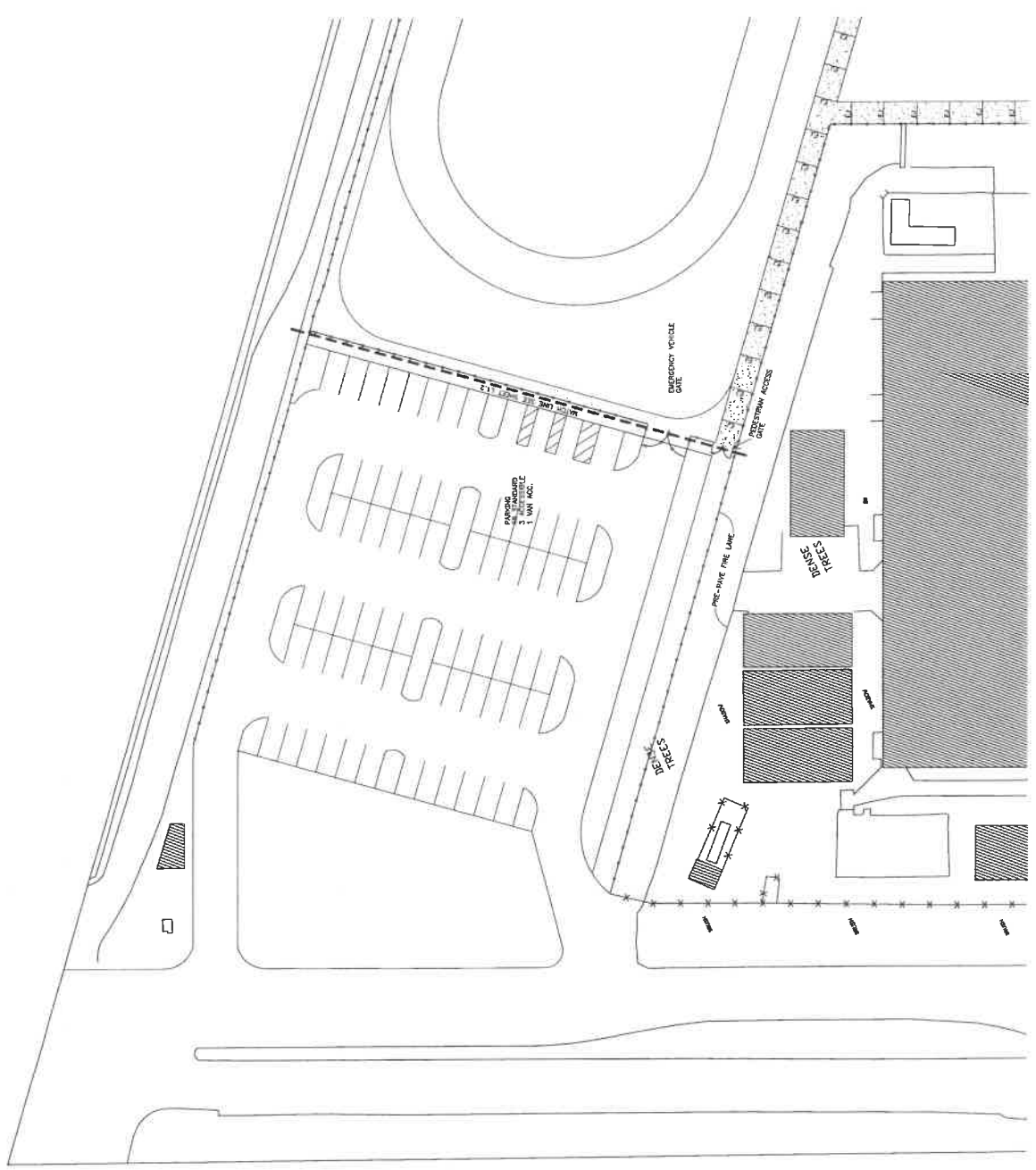

1. SITE PLAN
 SCALE: 1" = 20'-0"

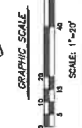

SHEET L1.3

TITLE

LANDSCAPE STAGING PLAN



KRUEGER BENSON ZIEGLER ARCHITECTS, INC. (KBZ)
 1000 FORTUNA ST. SUITE 100A, VENTURA, CA 93003
 TEL: 805.223.2222 FAX: 805.223.2223
 WWW.KRUEGERBENZENZIEGLER.COM
 PROJECT ARCHITECT
 JOE RUI YECOLAN
 DATE: 07/10/14
 SHEET: LANDSCAPE FINISHING PLAN



JORDAN, GILBERT, & BAIN LANDSCAPE ARCHITECTS, INC.
 1000 FORTUNA ST. SUITE 100A, VENTURA, CA 93003
 (805) 642-3841

REVISION RECORD
 NO. DATE BY
 1 07/10/14 JRY

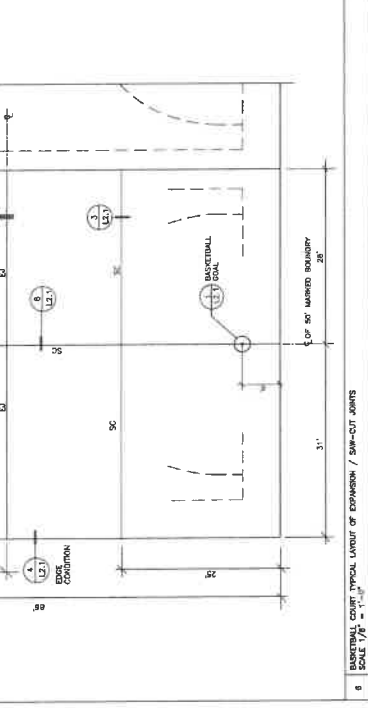
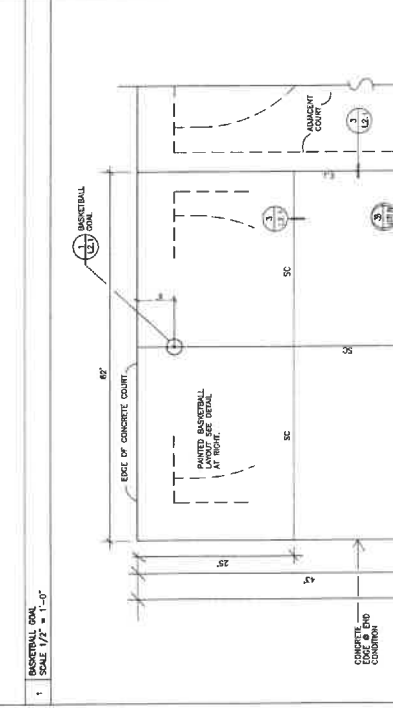
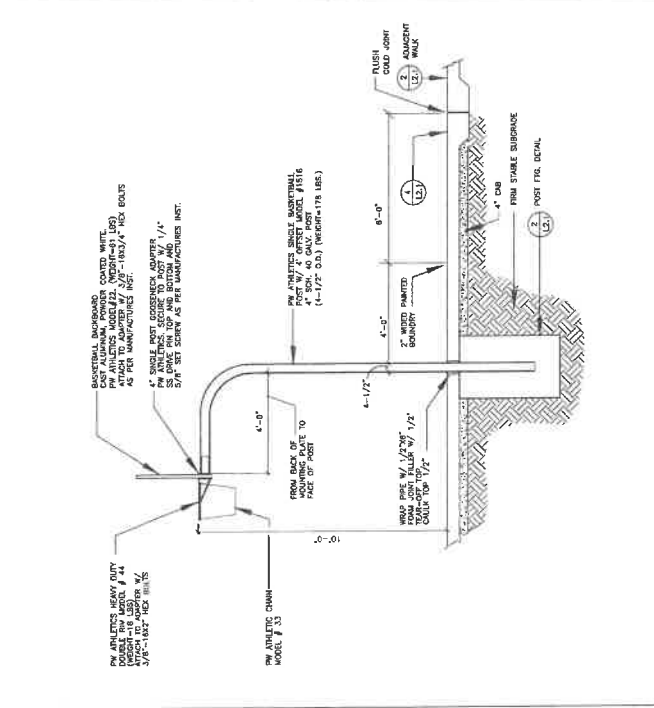
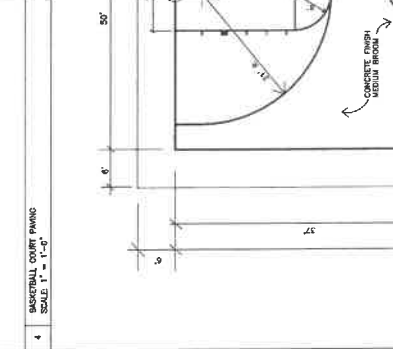
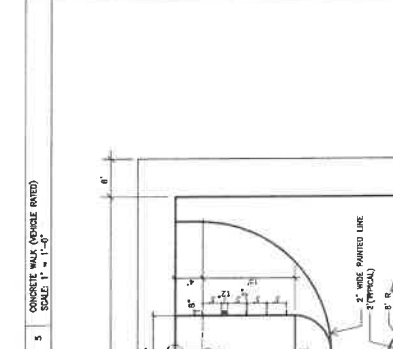
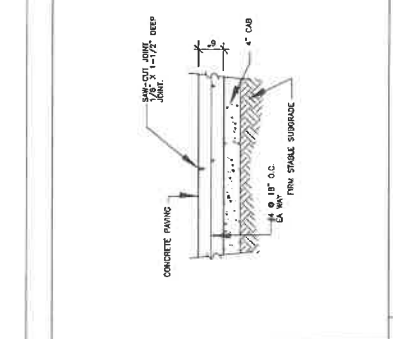
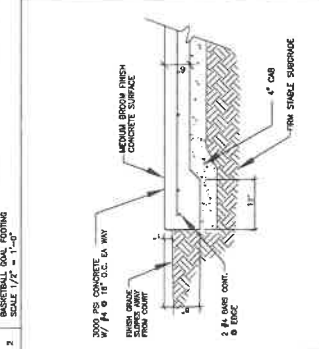
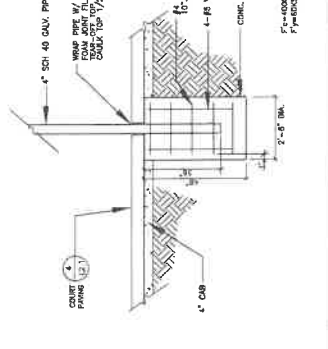
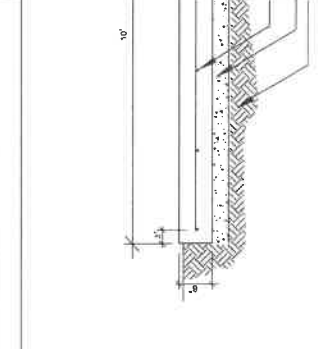
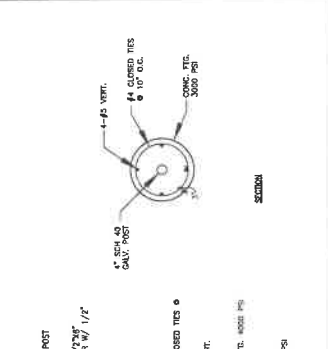
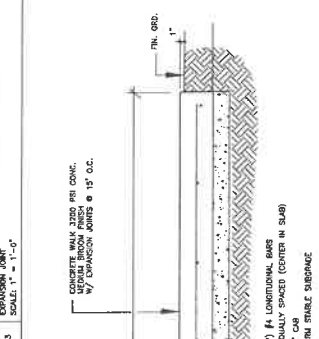
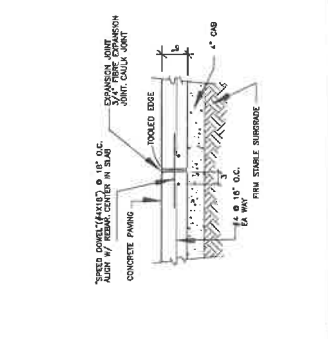



KRUGER BENSON ZIEMER ARCHITECTS, INC.
 13200 AVENUE 100
 SUITE 1000, WESTPORT, CA 94091
 AIA AIA
 JONATHAN D. LEE
 ARCHITECTURAL DESIGNER



JORDAN, GILBERT, & BAIN ARCHITECTS INC.
 458 NO. VENTURA AVE
 VENTURA CA 93001
 (805) 842-3841

DATE: 11/11/14
 CHECKED BY: PJ
 DRAWN BY: PJ
 CHECKED: MG
 DATE: 10/10/14
 SCALE: AS SHOWN

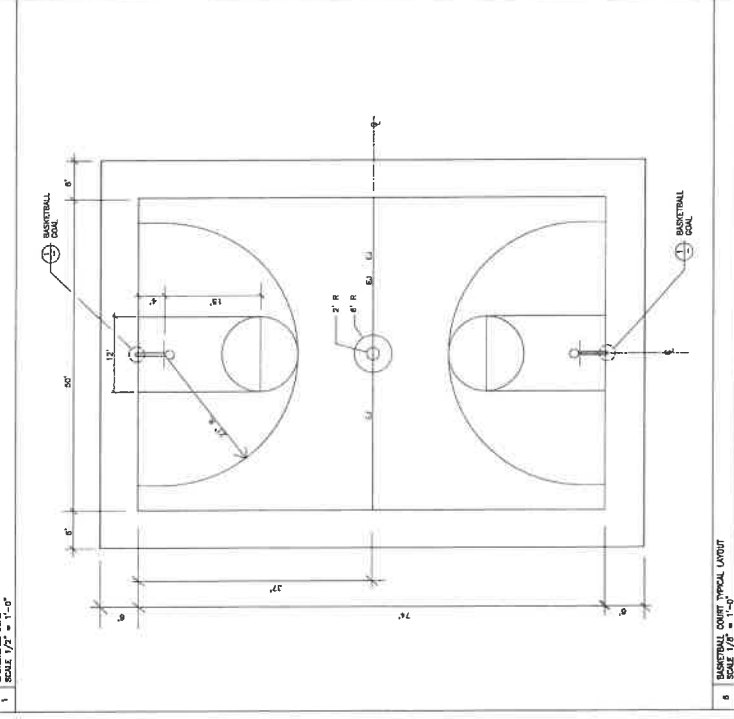
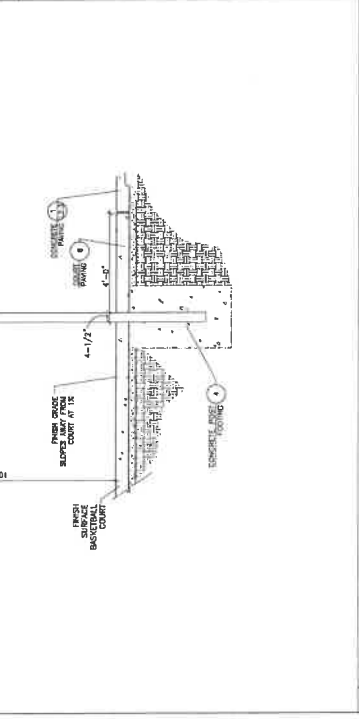
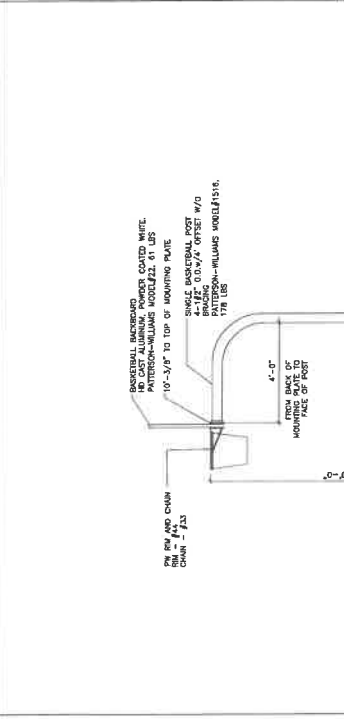
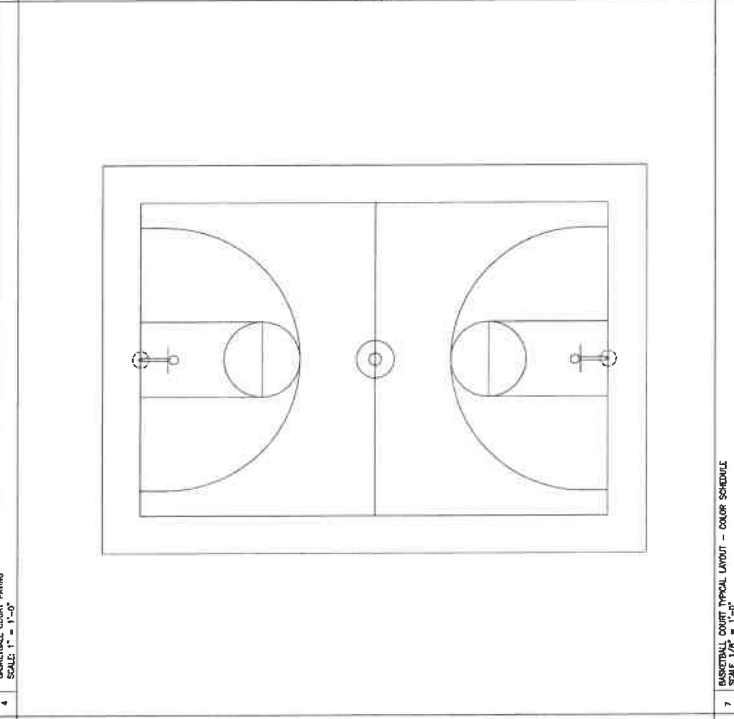
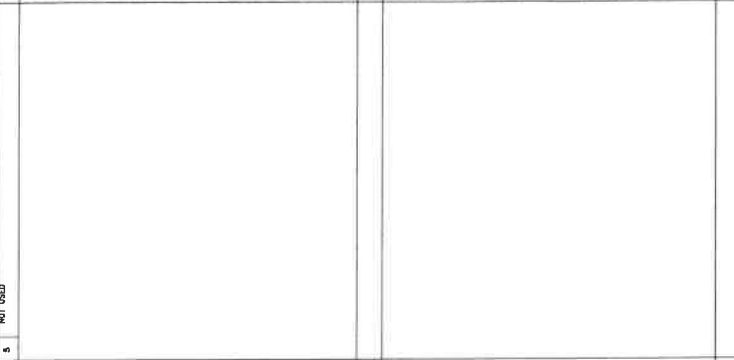
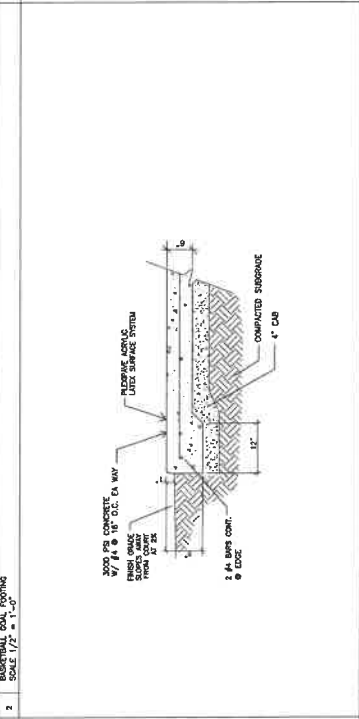
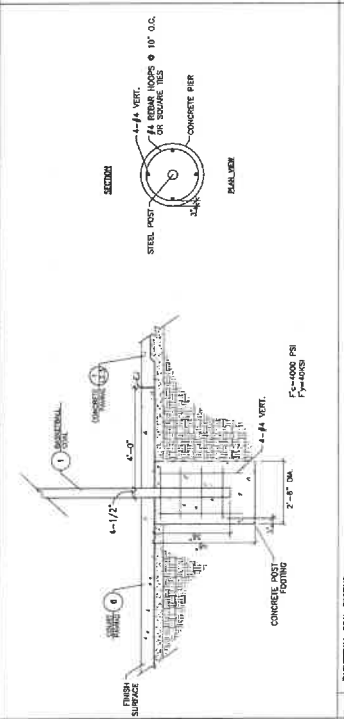
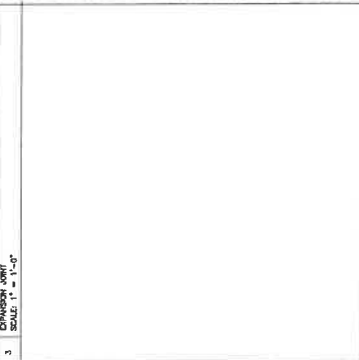
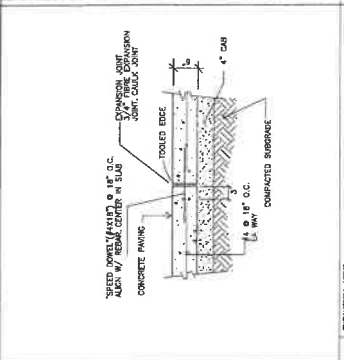



BRUNER BENSON ZEMER
 ARCHITECTS, INC. AIA
 400 HARRISON ST. SUITE 100A, VENTURA, CA 93001
 TEL: 805.233.3333
 FAX: 805.233.3334
 WWW: WWW.BRZARCHITECTS.COM
 PROJECT NO. 13-0001
 DATE: 12/15/13



JORDAN, GILBERT & BAIN
 LANDSCAPE ARCHITECTS INC.
 459 N.O. VENTURA AVE
 VENTURA, CA 93001
 (805) 842-3841

REVISION DESCRIPTION	DATE	BY
1.0		
2.0		
3.0		
4.0		
5.0		
6.0		
7.0		
8.0		
9.0		
10.0		
11.0		
12.0		
13.0		
14.0		
15.0		
16.0		
17.0		
18.0		
19.0		
20.0		
21.0		
22.0		
23.0		
24.0		
25.0		
26.0		
27.0		
28.0		
29.0		
30.0		
31.0		
32.0		
33.0		
34.0		
35.0		
36.0		
37.0		
38.0		
39.0		
40.0		
41.0		
42.0		
43.0		
44.0		
45.0		
46.0		
47.0		
48.0		
49.0		
50.0		
51.0		
52.0		
53.0		
54.0		
55.0		
56.0		
57.0		
58.0		
59.0		
60.0		
61.0		
62.0		
63.0		
64.0		
65.0		
66.0		
67.0		
68.0		
69.0		
70.0		
71.0		
72.0		
73.0		
74.0		
75.0		
76.0		
77.0		
78.0		
79.0		
80.0		
81.0		
82.0		
83.0		
84.0		
85.0		
86.0		
87.0		
88.0		
89.0		
90.0		
91.0		
92.0		
93.0		
94.0		
95.0		
96.0		
97.0		
98.0		
99.0		
100.0		



GRAPHIC SCALE
 0 5 10
 FEET
 SCALE: 1" = 20'

SHEET 13.1

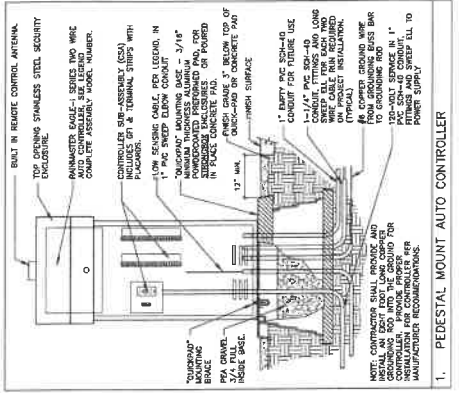

1. PEDESTAL MOUNT AUTO CONTROLLER

EXISTING CONDITIONS AT IRRIGATION WELL SOURCE / PUMP STATION
 THE EXISTING CENTRIFUGAL PUMP DRAWS WATER FROM THE EXISTING WELL USING A 3" CALIBER STEEL EXHAUST VALVE. THE 3" CALIBER SPRING CONTROLS ON GRADE THROUGH THE EXISTING VALVE. THE 3" CALIBER SPRING CONTROLS ON GRADE THROUGH THE SIDE OF THE TIE. THE PUMP IS REDUCED TO A SMALLER SIZE AND IS CONNECTED TO EXISTING PRESSURIZED BLUNDER MAIN. ON THE NORTH SIDE OF THE TIE, THE 3" CALIBER BRANCH OFF THE EXISTING PRESSURIZED BLUNDER MAIN. THE 3" CALIBER SPRING CONTROLS FROM THE 3" BRANCH OFF INTO THE NORTH THROUGH OUT THE CAMPUS.

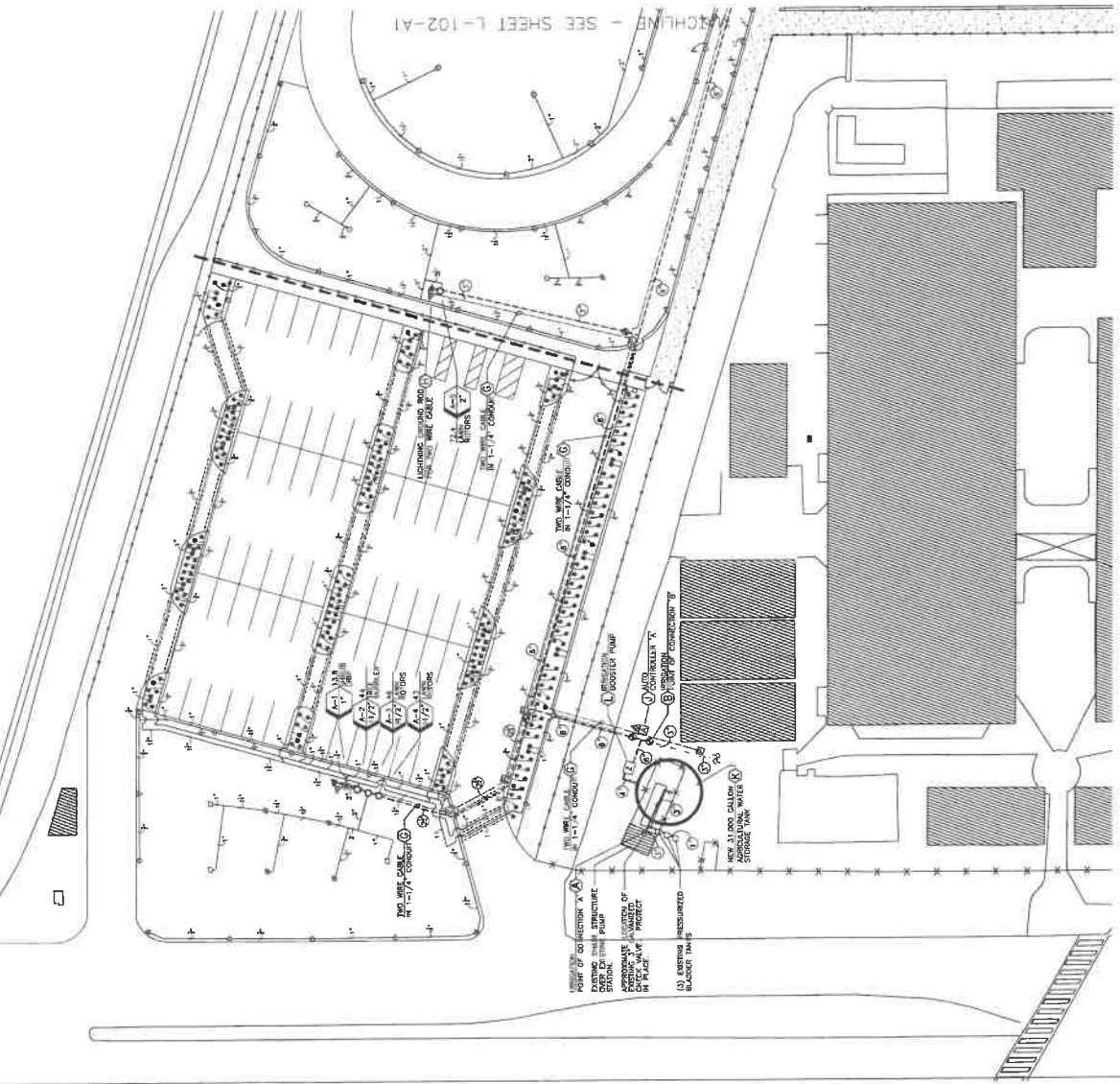

(1) EXISTING PRESSURIZED BLUNDER MAIN
 (2) NEW 3\"/>

ARCHLINE - SEE SHEET L-102-A1



JORDAN & RAIN
 LANDSCAPE ARCHITECTS, INC.
 459 NO. VENTURA AVE
 VENTURA, CA 93001
 (805) 642-3841



JONATHAN D. LEE
 AIA
 JORDAN & RAIN
 LANDSCAPE ARCHITECTS, INC.
 459 NO. VENTURA AVE
 VENTURA, CA 93001
 (805) 642-3841

REVISION DESCRIPTION	DATE	BY
1. INITIAL DESIGN		
2. REVISED NO.		
3. REVISED NO.		
4. REVISED NO.		
5. REVISED NO.		
6. REVISED NO.		
7. REVISED NO.		
8. REVISED NO.		
9. REVISED NO.		
10. REVISED NO.		
11. REVISED NO.		
12. REVISED NO.		
13. REVISED NO.		
14. REVISED NO.		
15. REVISED NO.		
16. REVISED NO.		
17. REVISED NO.		
18. REVISED NO.		
19. REVISED NO.		
20. REVISED NO.		
21. REVISED NO.		
22. REVISED NO.		
23. REVISED NO.		
24. REVISED NO.		
25. REVISED NO.		
26. REVISED NO.		
27. REVISED NO.		
28. REVISED NO.		
29. REVISED NO.		
30. REVISED NO.		
31. REVISED NO.		
32. REVISED NO.		
33. REVISED NO.		
34. REVISED NO.		
35. REVISED NO.		
36. REVISED NO.		
37. REVISED NO.		
38. REVISED NO.		
39. REVISED NO.		
40. REVISED NO.		
41. REVISED NO.		
42. REVISED NO.		
43. REVISED NO.		
44. REVISED NO.		
45. REVISED NO.		
46. REVISED NO.		
47. REVISED NO.		
48. REVISED NO.		
49. REVISED NO.		
50. REVISED NO.		
51. REVISED NO.		
52. REVISED NO.		
53. REVISED NO.		
54. REVISED NO.		
55. REVISED NO.		
56. REVISED NO.		
57. REVISED NO.		
58. REVISED NO.		
59. REVISED NO.		
60. REVISED NO.		
61. REVISED NO.		
62. REVISED NO.		
63. REVISED NO.		
64. REVISED NO.		
65. REVISED NO.		
66. REVISED NO.		
67. REVISED NO.		
68. REVISED NO.		
69. REVISED NO.		
70. REVISED NO.		
71. REVISED NO.		
72. REVISED NO.		
73. REVISED NO.		
74. REVISED NO.		
75. REVISED NO.		
76. REVISED NO.		
77. REVISED NO.		
78. REVISED NO.		
79. REVISED NO.		
80. REVISED NO.		
81. REVISED NO.		
82. REVISED NO.		
83. REVISED NO.		
84. REVISED NO.		
85. REVISED NO.		
86. REVISED NO.		
87. REVISED NO.		
88. REVISED NO.		
89. REVISED NO.		
90. REVISED NO.		
91. REVISED NO.		
92. REVISED NO.		
93. REVISED NO.		
94. REVISED NO.		
95. REVISED NO.		
96. REVISED NO.		
97. REVISED NO.		
98. REVISED NO.		
99. REVISED NO.		
100. REVISED NO.		



SHEET L3.2

← PH. 1 PH. 2 →

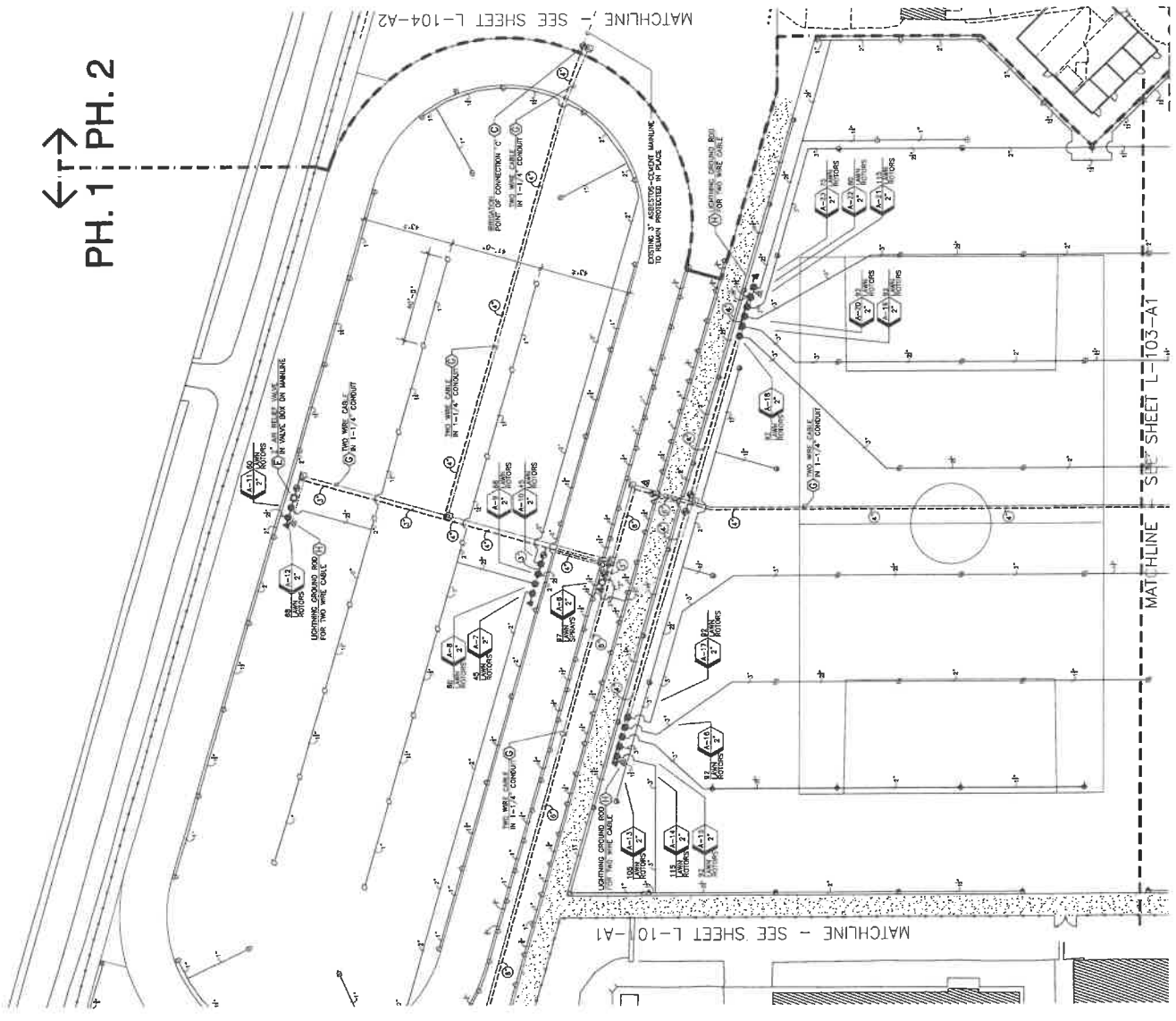

MATCHLINE - SEE SHEET L-10-A1

MATCHLINE - SEE SHEET L-104-A2

MATCHLINE - SEE SHEET L-103-A1



KRUEGER BENSON ZIEEMER
ARCHITECTS, INC. AIA
3100 NORTH ROSE AVENUE SUITE 200
OXNARD, CALIFORNIA 93036
TEL: (805) 438-7777
WWW.KRUEGERBENZONZIEEMER.COM

TODD A. JESPERSEN,
PRINCIPAL ARCHITECT
LISA M. LEE
ARCHITECT



JORDAN, GILBERT, & BANN
LANDSCAPE ARCHITECTS INC.
3100 NORTH ROSE AVENUE
SUITE 200
OXNARD, CALIFORNIA 93036
(805) 942-3841

▲	CONCRETE
▲	ASPHALT
▲	PAVING
▲	GRASS
▲	PLANTING
▲	DATE
▲	BY

DESIGNED BY
DATE
DRAWN BY
DATE

PROJECT
SHEET

L3.3

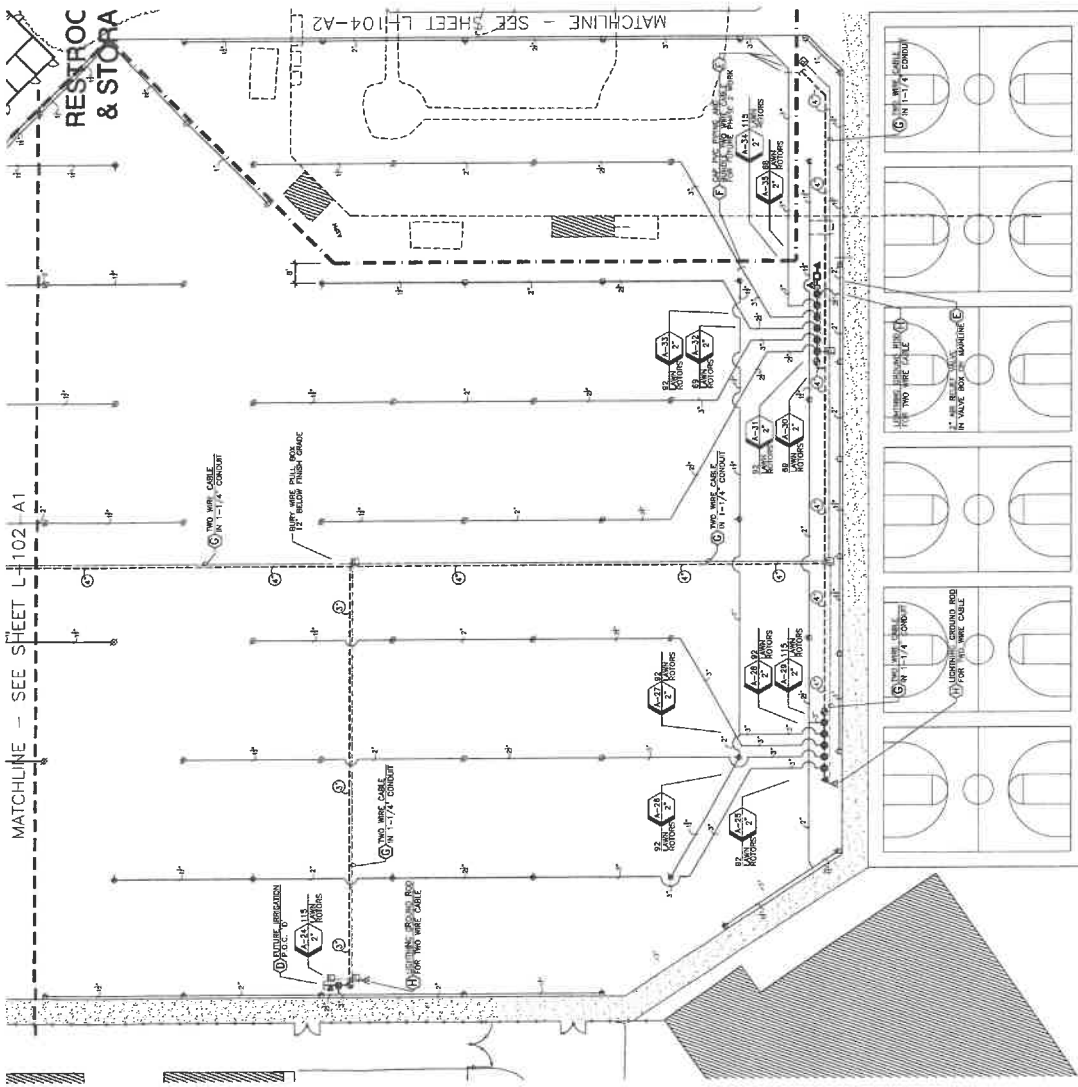



KRUGER BENSON ZEMER
ARCHITECTS
1900 RIVER STREET, SUITE 100, OAKLAND, CA 94612
TEL: 510.763.9800
FAX: 510.763.9801
WWW.KRUGERBENZENZEMER.COM

JOYATHAN D. LEE
REGISTERED CIVIL ENGINEER
NO. 17503
EXPIRES 12/31/2015
CITY OF OAKLAND, CALIFORNIA



JORDAN LEE & BRIAN
LANDSCAPE ARCHITECTS INC.
459 NO. VENTURA AVE
VENTURA, CA 93001
(805) 842-3841

DATE: 12/12/14
BY: [Signature]
REVISION DESCRIPTION:
DATE: 12/12/14
BY: [Signature]

DRAWN: JB
CHECKED: MD
DATE: 12/12/14
JOB NO: 14-1002A
SHEET: IRRIGATION PLAN

TITLE

SHEET

L3.4

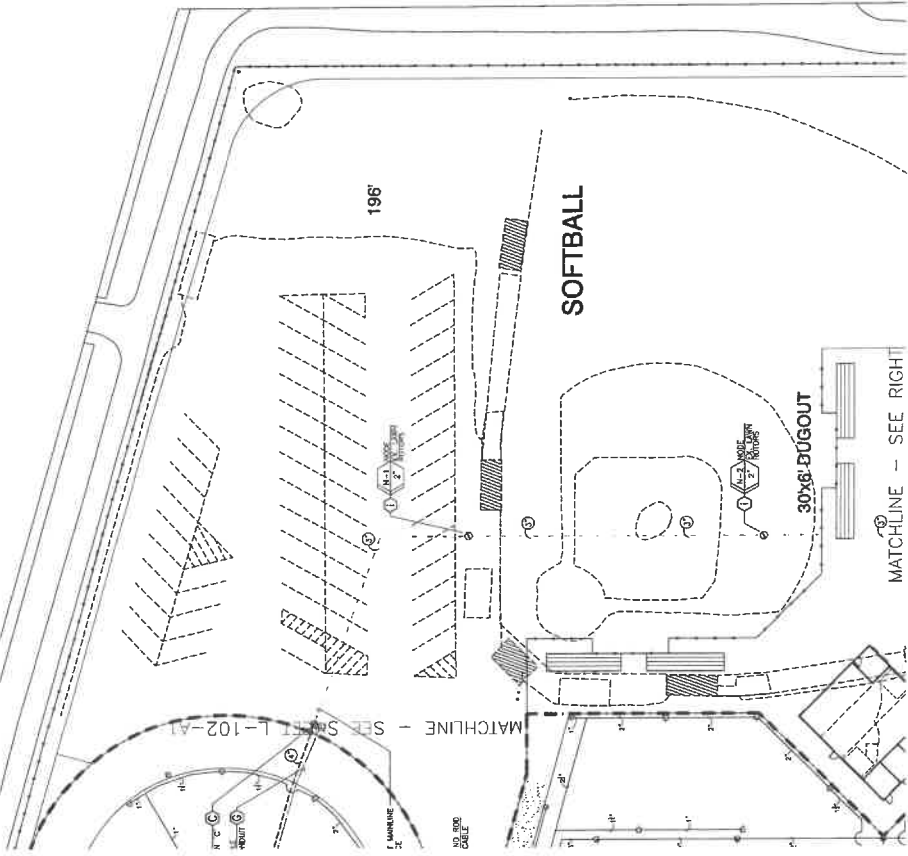
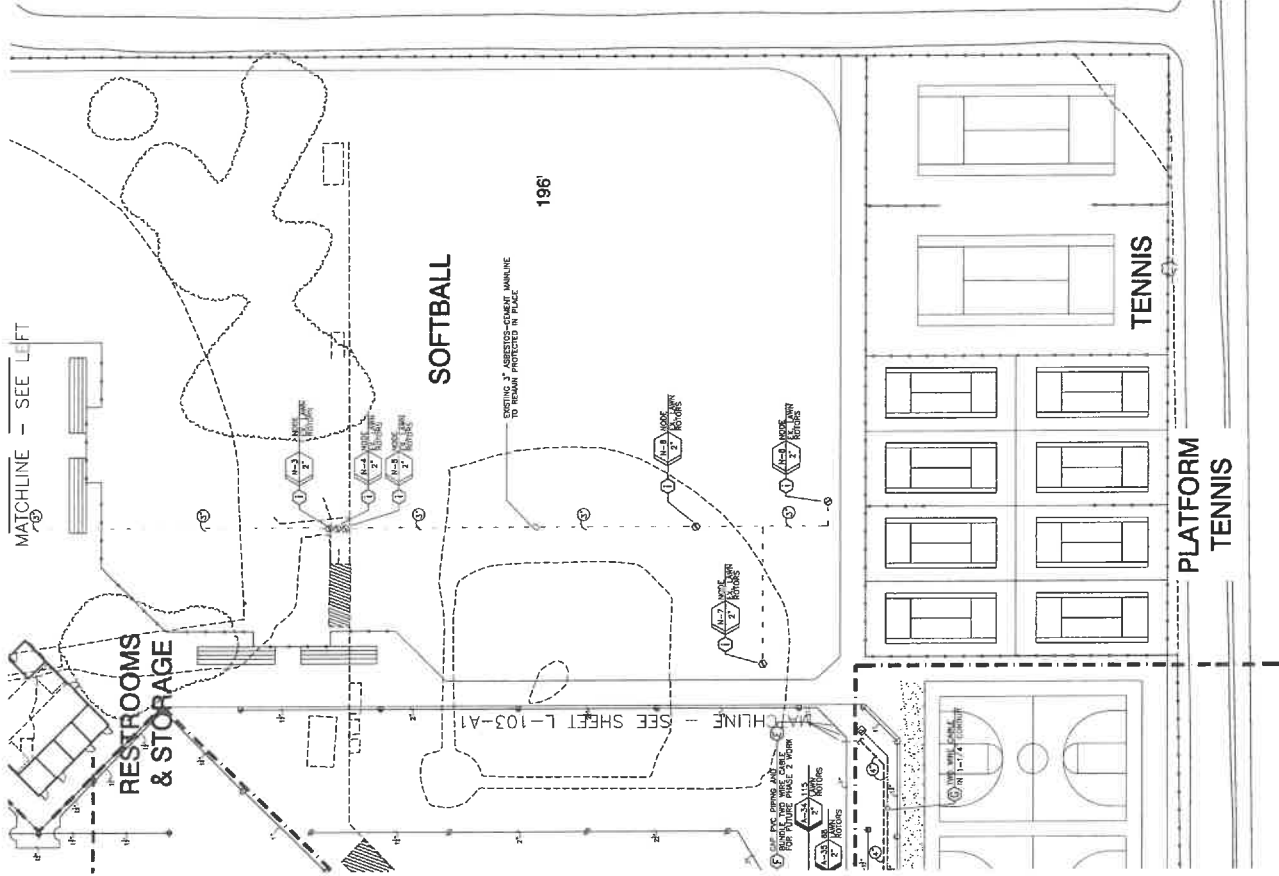
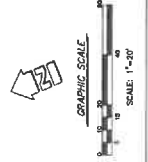

PROJECT NOTES

- 1. FROM TO BE BOUND BY THE CONTRACTOR AND THE RNO SCHOOL DISTRICT REPRESENTATIVE SHALL PARTICIPATE IN A THROUGH-IRIGATION SYSTEM TO BE BOUND BY THE CONTRACTOR AND THE RNO SCHOOL DISTRICT REPRESENTATIVE...
2. CONTRACTOR SHALL BE RESPONSIBLE FOR ANY WORK NECESSARY TO PREVENT IRIGATION SYSTEM FROM BEING AFFECTED BY OTHER WORK...
3. CONTRACTOR SHALL BE RESPONSIBLE FOR ANY WORK NECESSARY TO PREVENT IRIGATION SYSTEM FROM BEING AFFECTED BY OTHER WORK...
4. CONTRACTOR SHALL BE RESPONSIBLE FOR ANY WORK NECESSARY TO PREVENT IRIGATION SYSTEM FROM BEING AFFECTED BY OTHER WORK...
5. CONTRACTOR SHALL BE RESPONSIBLE FOR ANY WORK NECESSARY TO PREVENT IRIGATION SYSTEM FROM BEING AFFECTED BY OTHER WORK...
6. CONTRACTOR SHALL BE RESPONSIBLE FOR ANY WORK NECESSARY TO PREVENT IRIGATION SYSTEM FROM BEING AFFECTED BY OTHER WORK...
7. CONTRACTOR SHALL BE RESPONSIBLE FOR ANY WORK NECESSARY TO PREVENT IRIGATION SYSTEM FROM BEING AFFECTED BY OTHER WORK...
8. CONTRACTOR SHALL BE RESPONSIBLE FOR ANY WORK NECESSARY TO PREVENT IRIGATION SYSTEM FROM BEING AFFECTED BY OTHER WORK...
9. CONTRACTOR SHALL BE RESPONSIBLE FOR ANY WORK NECESSARY TO PREVENT IRIGATION SYSTEM FROM BEING AFFECTED BY OTHER WORK...
10. CONTRACTOR SHALL BE RESPONSIBLE FOR ANY WORK NECESSARY TO PREVENT IRIGATION SYSTEM FROM BEING AFFECTED BY OTHER WORK...

IRRIGATION LEGEND

Table with columns: SYMBOL, DESCRIPTION, MATERIALS/QUANTITIES, and SCALE. Includes items for various pipe types, valves, pumps, and electrical components.

PROJECT KEY NOTES

- 1. IRRIGATION SYSTEM SHALL BE DESIGNED AND CONSTRUCTED TO MEET THE DESIGN CRITERIA...
2. CONTRACTOR SHALL BE RESPONSIBLE FOR OBTAINING ALL NECESSARY PERMITS...
3. CONTRACTOR SHALL BE RESPONSIBLE FOR OBTAINING ALL NECESSARY PERMITS...
4. CONTRACTOR SHALL BE RESPONSIBLE FOR OBTAINING ALL NECESSARY PERMITS...
5. CONTRACTOR SHALL BE RESPONSIBLE FOR OBTAINING ALL NECESSARY PERMITS...
6. CONTRACTOR SHALL BE RESPONSIBLE FOR OBTAINING ALL NECESSARY PERMITS...
7. CONTRACTOR SHALL BE RESPONSIBLE FOR OBTAINING ALL NECESSARY PERMITS...
8. CONTRACTOR SHALL BE RESPONSIBLE FOR OBTAINING ALL NECESSARY PERMITS...
9. CONTRACTOR SHALL BE RESPONSIBLE FOR OBTAINING ALL NECESSARY PERMITS...
10. CONTRACTOR SHALL BE RESPONSIBLE FOR OBTAINING ALL NECESSARY PERMITS...

RIO DEL VALLE MIDDLE SCHOOL
SPORTS FIELDS COMPLEX - PHASE 1



JORDAN GILBERT & BAIN
LANDSCAPE ARCHITECTS INC.
489 N. VENTURA AVE.
VENTURA CA 93001
(805) 842-3541



STEVEN A. LEE
REGISTERED PROFESSIONAL ENGINEER
STATE OF CALIFORNIA
No. 46460
EXPIRES 12/31/13

Table with columns: REVISION, DATE, and DESCRIPTION. Includes entries for 'REVISION RESPONSE' and 'DATE'.

3.5



KRUGER JENSEN ZEHNER
 ARCHITECTS
 1000 S. GARDEN STREET, SUITE 200
 OAKLAND, CA 94612
 (415) 763-1234
 www.kjz.com

OWATYAN, D. LEE
 ARCHITECT
 1000 S. GARDEN STREET, SUITE 200
 OAKLAND, CA 94612
 (415) 763-1234
 www.kjz.com



JORDAN GILBERT & BAIN
 LANDSCAPE ARCHITECTS INC.
 489 NO. VENTURA AVE
 VENTURA CA 93001
 (805) 642-3841

REVISION DESCRIPTION	DATE	BY

DATE: 10/15/18
 DRAWN BY: [Signature]
 CHECKED BY: [Signature]
 SHEET: LANDSCAPE STAGING PLAN

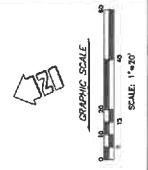
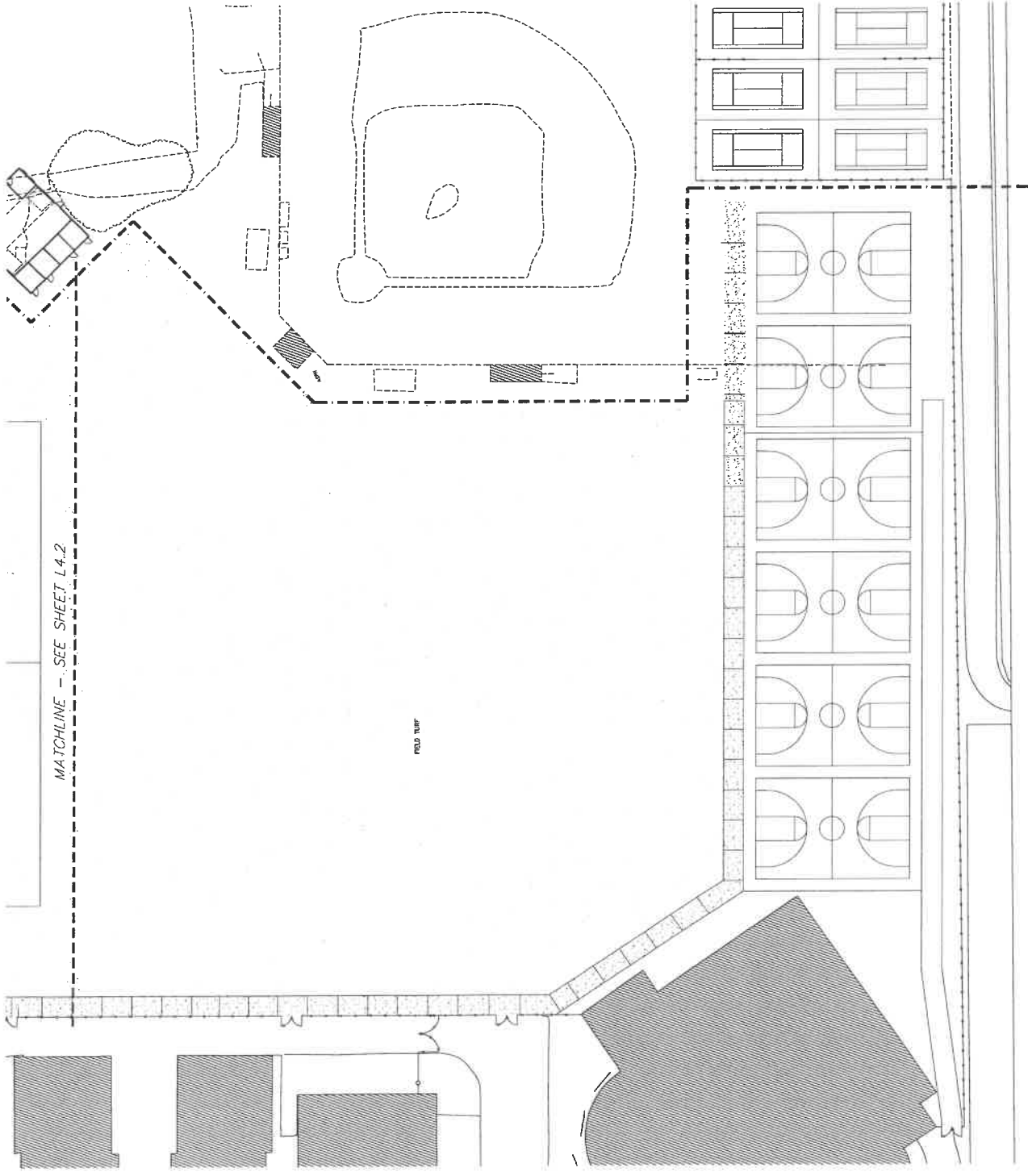

L4.1
 LANDSCAPE STAGING PLAN
 SCALE: 1" = 30'-0"

SHEET L4.1



JORDAN, GILBERT & BAIN
 LANDSCAPE ARCHITECTS INC.
 450 NO. VENTURA AVE
 VENTURA CA 93001
 (805) 642-3841



DESIGNED BY
 DRAWN BY
 CHECKED BY
 DATE

REVISION DESCRIPTION
 DATE

PROJECT: LANDSCAPE PLANNING
 SHEET: L4.2

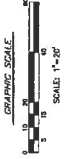

← T →
 PH. 1 PH. 2

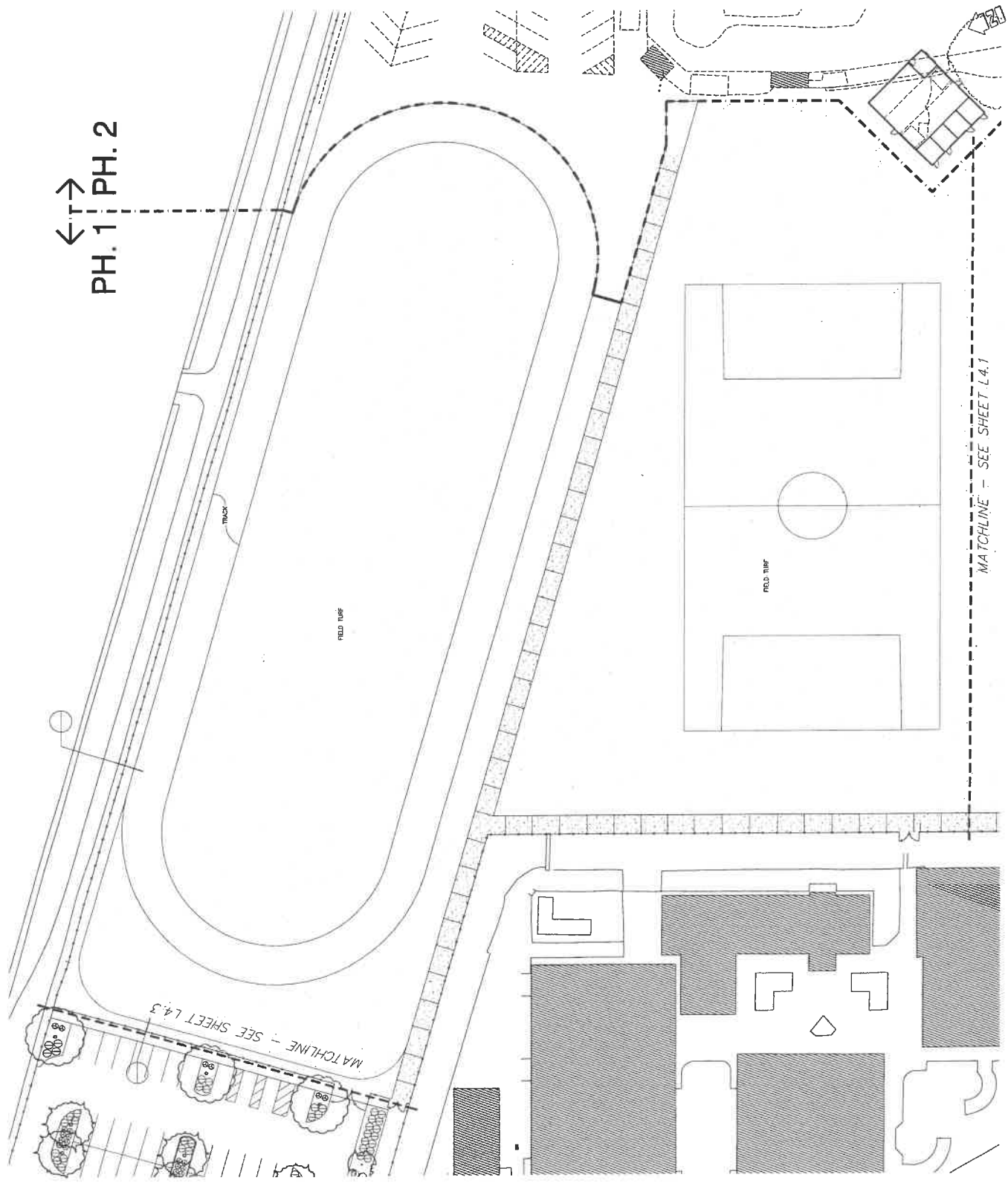

DATE: 10/15/19
 JOB NO: 19032A

SCALE: 1" = 20'



KRUCZE GENSER ZEMER
 ARCHITECTS
 1000 BAY STREET, SUITE 200
 SAN FRANCISCO, CA 94133
 TEL: 415.774.1100
 WWW.KRUCZEGENZEMER.COM



JONATHAN D. LEE
 CIVIL ENGINEER
 LICENSE NO. 45678
 STATE OF CALIFORNIA

JORDAN GILLESPIE & BAN
 LANDSCAPE ARCHITECTS INC.
 459 NO. VENTURA AVE
 VENTURA, CA 93001
 (805) 642-3841

REVISION	DESCRIPTION	DATE	BY
1	ISSUED FOR PERMIT		
2	ISSUED FOR PERMIT		
3	ISSUED FOR PERMIT		
4	ISSUED FOR PERMIT		
5	ISSUED FOR PERMIT		
6	ISSUED FOR PERMIT		
7	ISSUED FOR PERMIT		
8	ISSUED FOR PERMIT		
9	ISSUED FOR PERMIT		
10	ISSUED FOR PERMIT		

DRAWN BY: JG
 CHECKED BY: JG
 DATE: 12/15/19
 JOB NO: 19022A
 SHEET: LANDSCAPE STAGING PLAN
 TITLE

SHEET L4.3

PHASE 1 PLANTING LEGEND

TREES SYMBOL	QTY	SIZE	SCIENTIFIC NAME / COMMON NAME	HEIGHT / SPREAD	DETAIL REF.
	9	24" BOX STANDARD	QUERCUS PINEA / PINENUT OAK	9'-11" x 3'-4"	1/4.1
	12	24" BOX STANDARD	LEUCODENDRON BICOLOR / WHITE BARK CEDAR	7'-8" x 3'-4"	1/4.1
	4	24" BOX STANDARD	QUERCUS PINEA / PINENUT OAK	9'-11" x 3'-4"	1/4.1
SHRUBS SYMBOL	QTY	SIZE	SCIENTIFIC NAME / COMMON NAME	DETAIL REF.	
	64	5 GAL	RHAMNUS ALBIFLORA / WHITE FLAME TREE	1/4.1	
	67	5 GAL	LEUCODENDRON BICOLOR / WHITE BARK CEDAR	1/4.1	
	116	5 GAL	LEUCODENDRON BICOLOR / WHITE BARK CEDAR	1/4.1	

GROUND COVERS SYMBOL

SYMBOL	TYPE	DESCRIPTION
	FIELD TURF	SPORTSFIELD MIX TURF
		SEE SPEC'S

CRITICAL PLANTING NOTES:

1. ALL 24" BOX TURF AREAS SHALL BE PLANTED WITH SPORTSFIELD MIX TURF.
2. TREES IN TURF AREAS SHALL HAVE A 30" WOOD MULCH RING AROUND THE TRUNK.
3. TREES SHALL HAVE ROOT BARRIERS PER DETAIL 3, SHEET L-002.

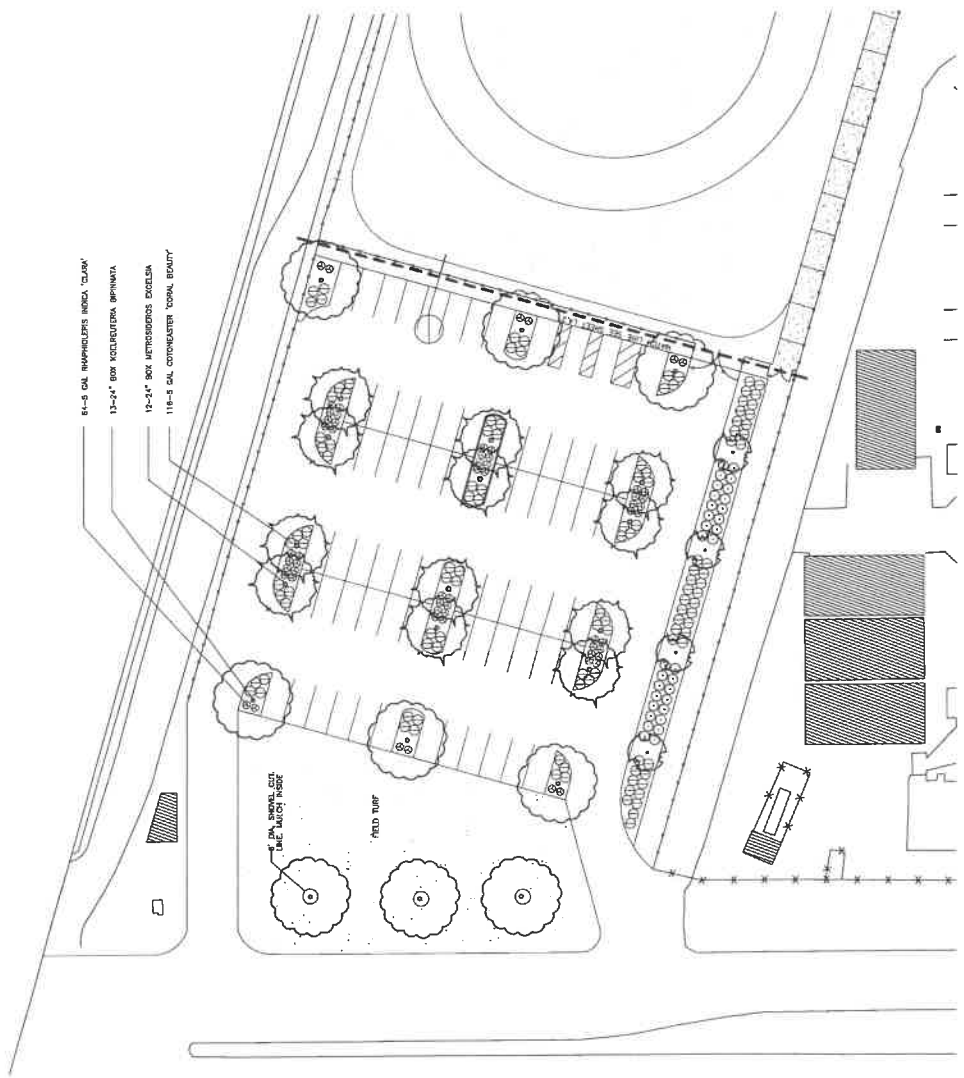

SCALE: 1" = 30'-0"

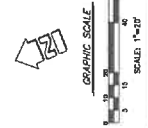



ROYER BERSON DESIGN
 LANDSCAPE ARCHITECTS INC.
 459 NO. VENTURA AVE
 VENTURA CA 93001
 (805) 642-3841

DATE: 11/11/11
 DRAWN BY: JLB
 CHECKED BY: JLB
 APPROVED BY: JLB
 REGION: OXNARD
 SHEET: IRRIGATION DETAILS
 PROJECT: RIO DEL VALLE MIDDLE SCHOOL
 SHEET NO: 10000A
 DATE: 11/11/11

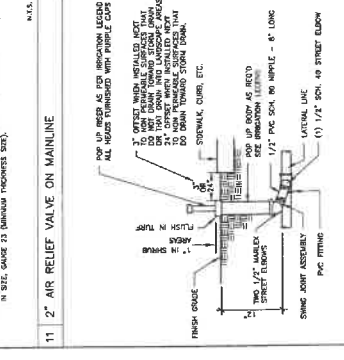
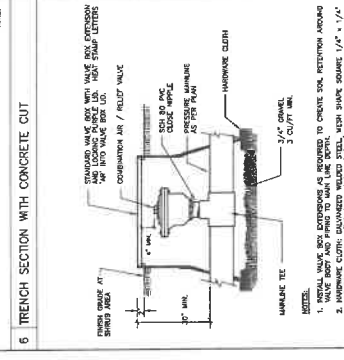
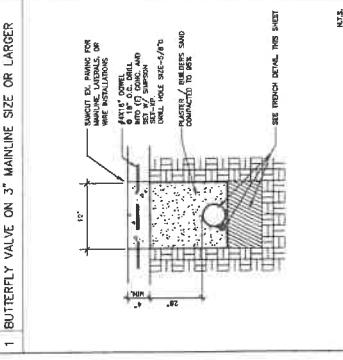
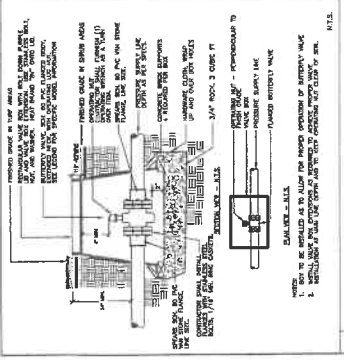
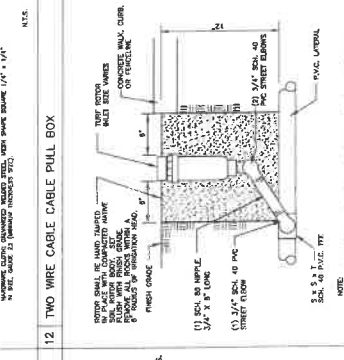
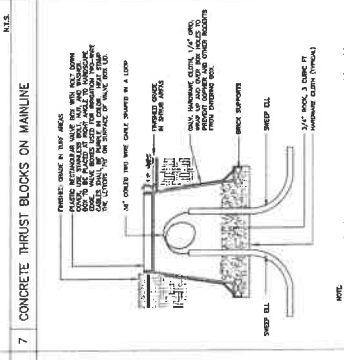
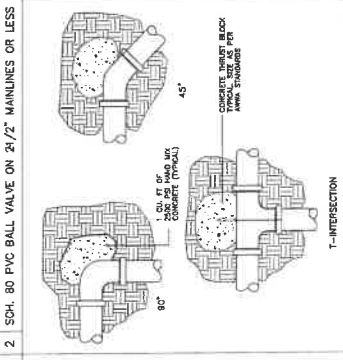
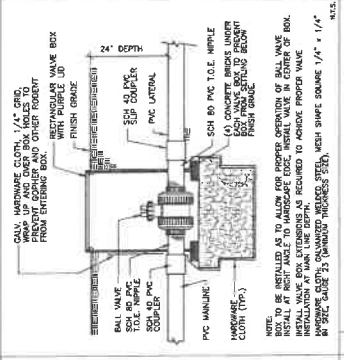
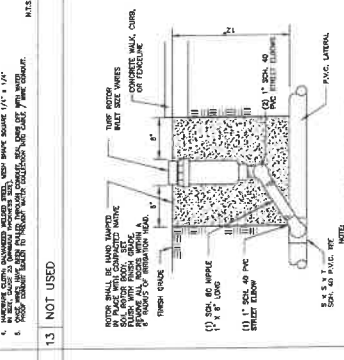
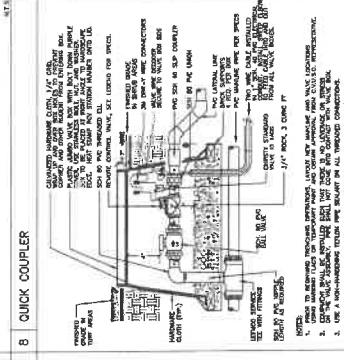
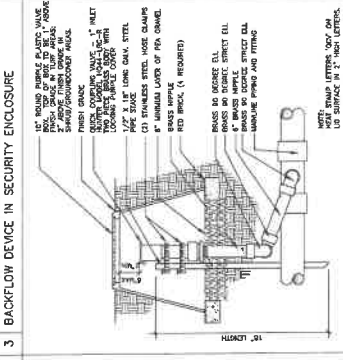
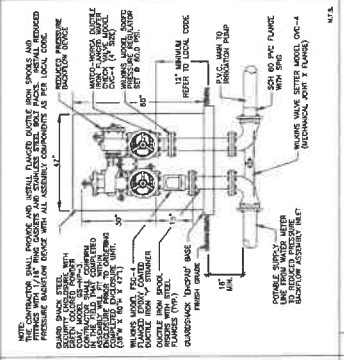
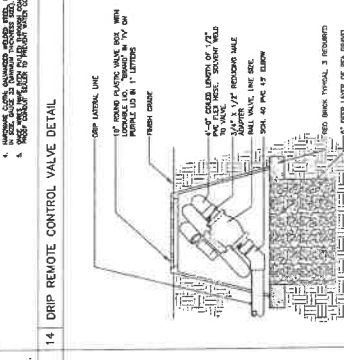
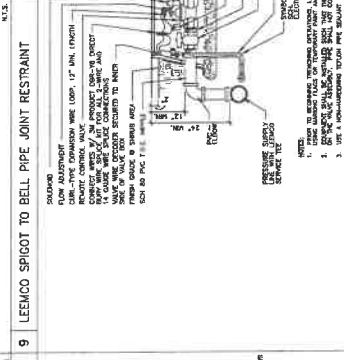
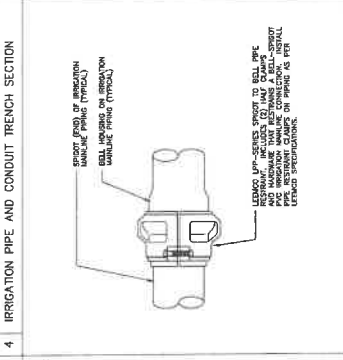
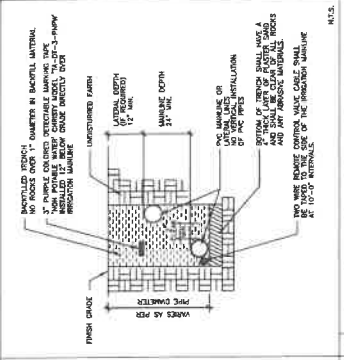
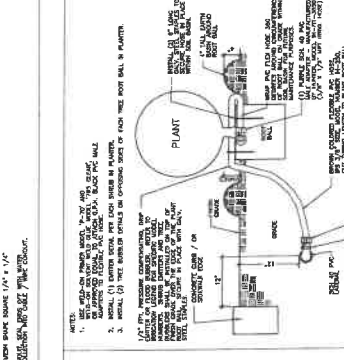
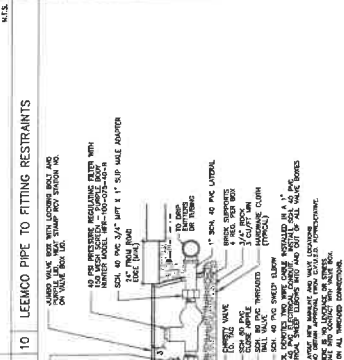
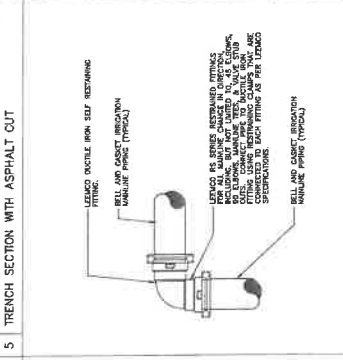
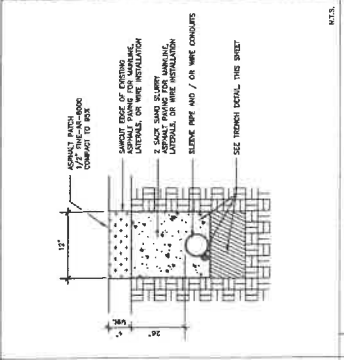



KRUGER BENZEN ZELLER
 ARCHITECTS
 1000 NORTH ROSE AVENUE, OXNARD, CA 93026
 TEL: (805) 461-1111
 FAX: (805) 461-1112
 WWW: KRUGERBENZENZELLER.COM

CONSULTANT D. LEE
 LANDSCAPE ARCHITECTS
 488 NORTH BERT AVENUE, VENTURA, CA 93001
 TEL: (805) 642-3841
 WWW: CDLEE.COM

JORDAN E. BERT & BAIN
 CIVIL ENGINEERS
 488 NORTH BERT AVENUE
 VENTURA, CA 93001
 (805) 642-3841

DATE: _____ BY: _____
 CHECKED: _____
 DRAWN: _____
 REVISION DESCRIPTION: _____
 SHEET: LANDSCAPE DETAILS
 FILE: _____

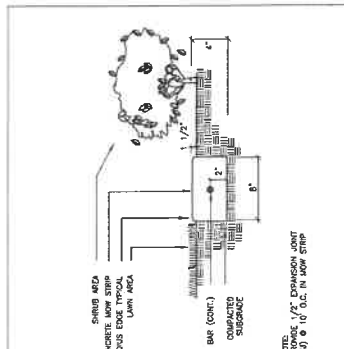
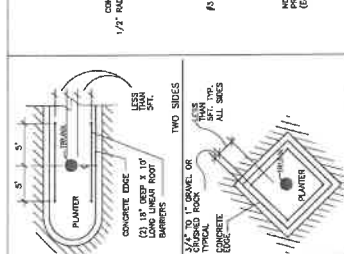
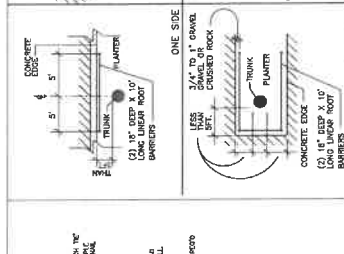
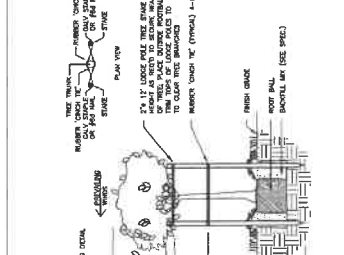
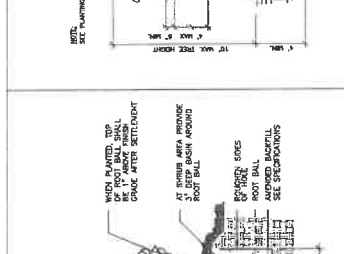
<p>1 TREE & SHRUB PLANTING NOT TO SCALE</p>  <p>NOTE: 1/2" TRUNK DIA. (TYPICAL) 1/2" IN LOW STOP (3) 1/2" DEEP X 10' LONG LINEAR ROOT BARRIERS</p>	<p>2 TREE STAKING - 24" BOX AND SMALLER NOT TO SCALE</p>  <p>NOTE: 1/2" TRUNK DIA. (TYPICAL) 1/2" IN LOW STOP (3) 1/2" DEEP X 10' LONG LINEAR ROOT BARRIERS</p>	<p>3 TREE ROOT BARRIER NOT TO SCALE</p>  <p>NOTE: 1/2" TRUNK DIA. (TYPICAL) 1/2" IN LOW STOP (3) 1/2" DEEP X 10' LONG LINEAR ROOT BARRIERS</p>	<p>4 CONCRETE HEADER NOT TO SCALE</p>  <p>NOTE: 1/2" TRUNK DIA. (TYPICAL) 1/2" IN LOW STOP (3) 1/2" DEEP X 10' LONG LINEAR ROOT BARRIERS</p>	<p>5 CONCRETE HOW STRIP @ CHAIN LINK FENCE SCALE: 1/4"=1'-0"</p>  <p>NOTE: 1/2" TRUNK DIA. (TYPICAL) 1/2" IN LOW STOP (3) 1/2" DEEP X 10' LONG LINEAR ROOT BARRIERS</p>	<p>6 NOT USED</p>	<p>7 NOT USED</p>	<p>8 NOT USED</p>	<p>9 NOT USED</p>	<p>10 NOT USED</p>	<p>11 NOT USED</p>
--	---	---	--	---	--------------------------	--------------------------	--------------------------	--------------------------	---------------------------	---------------------------



KENNER BENSEN BECKER
 ARCHITECTS, INC. AIA
 885 FORTUNA ST. SUITE 100, OXFORD, CA 95356
 TEL: (916) 835-1100 FAX: (916) 835-1101
 WWW.KBBARCHITECTS.COM
 TODD A. BEERSPENSEN, AIA
 LEAD ARCHITECT

JORDAN GILBERT & BAIN
 LANDSCAPE ARCHITECTS INC.
 458 NO. VENTURA AVE
 VENTURA CA 93001
 (805) 642-3541



JORDAN GILBERT & BAIN
 LANDSCAPE ARCHITECTS INC.
 458 NO. VENTURA AVE
 VENTURA CA 93001
 (805) 642-3541

REVISIONS:
 NO. DESCRIPTION
 DATE BY

DATE: 02/15/19
 JOB NO: 19023A
 SHEET: LANDSCAPE STAGING PLAN

<p>1 TREE & SHRUB PLANTING NOT TO SCALE</p>	<p>2 TREE STAKING - 24\"/> NOT TO SCALE</p>	<p>3 TREE ROOT BARRIER NOT TO SCALE</p>	<p>NOT TO SCALE</p>
--	--	--	---------------------

10.2

**Agenda Item Details**

Meeting	Mar 17, 2021 - RSD Regular Board Meeting
Category	10. Consent
Subject	10.2 Approval of the Minutes of the Special Board Meeting of February 3, 2021
Access	Public
Type	Action (Consent), Minutes
Minutes	View Minutes for Feb 3, 2021 - Rio School District Special Board Meeting

Public Content

Speaker:

Rationale:

MinSpec020321.pdf (48 KB)

Administrative Content**Executive Content**

Our adopted rules of Parliamentary Procedure, Robert's Rules, provide for a consent agenda listing several items for approval of the Board by a single motion. Most of the items listed under the consent agenda have gone through Board subcommittee review and recommendation. Documentation concerning these items has been provided to all Board members and the public in advance to assure an extensive and thorough review. Items may be removed from the consent agenda at the request of any board member.



**Rio School District
Minutes
Special Board Meeting
February 3, 2021
Rio School District
1800 Solar Drive
Oxnard, CA 93030
Open Session: 5:00 p.m.**

Members present

Edith Martinez-Cortes, Linda Armas, Cassandra Bautista, Kristine Anderson

1. Preliminary Business

1.1 Call to Order-5:00 p.m.

President Bautista called the meeting to order at 5:00 p.m.

1.2 Pledge of Allegiance

President Bautista led the flag salute.

1.3 Roll Call

President Bautista called the roll, Trustee Torres was absent.

2. Approval of the Agenda

2.1 Agenda corrections, additions, and modifications.

There were no corrections or modifications.

2.2 Approval of the Agenda

Staff recommends approval of the agenda as presented.

Motion by Linda Armas, second by Edith Martinez-Cortes.

Final Resolution: Motion Carries

Yes: Edith Martinez-Cortes, Linda Armas, Cassandra Bautista, Kristine Anderson

3. Open Session 5:00

3.1 Public Comment Procedures for receiving communication from the public on topics that fall under the subject jurisdiction of the Governing Board. 1. Special Board Meeting - A member of the public may address the Governing Board on any item(s) on the agenda. (Each person speaking may not exceed a total of three minutes on each item). The speaker may choose to speak during public comment or at the time of the agenda item prior to board consideration. These presentations are limited to three minutes or a total of twenty minutes.

Public comments were heard from Mary Walzer.

4. Information/Action

4.1 Master Planning Workshop

Superintendent Puglisi and Assistant Superintendent, Mr. Saleh began the presentation with a review and update on the master plan, goals accomplished and progress, recommendations for next steps also a funding timeline and enrollment. Guest speakers included Olivia Graf Doyle and Dr. Joel Kirschenstein.

5. Adjournment

5.1 Adjournment

President Bautista adjourned the meeting at 6:59 p.m.

Approved on this 17th day of March, 2021.

John Puglisi, Ph.D., Secretary

Date

Eleanor Torres, Clerk of the Board

Date

10.3

**Agenda Item Details**

Meeting	Mar 17, 2021 - RSD Regular Board Meeting
Category	10. Consent
Subject	10.3 Approval of the Minutes of the Special Board Meeting of February 9, 2021
Access	Public
Type	Action (Consent), Minutes
Minutes	View Minutes for Feb 9, 2021 - Rio School District Special Board Meeting

Public Content

Speaker:

Rationale:

MinSpec020921.pdf (48 KB)

Administrative Content**Executive Content**

Our adopted rules of Parliamentary Procedure, Robert's Rules, provide for a consent agenda listing several items for approval of the Board by a single motion. Most of the items listed under the consent agenda have gone through Board subcommittee review and recommendation. Documentation concerning these items has been provided to all Board members and the public in advance to assure an extensive and thorough review. Items may be removed from the consent agenda at the request of any board member.



**Rio School District
Minutes
Special Board Meeting
February 9, 2021
Rio School District
1800 Solar Drive
Oxnard, CA 93030
Open Session: 5:00 p.m.**

Members present

Eleanor Torres, Edith Martinez-Cortes, Linda Armas, Cassandra Bautista, Kristine Anderson

1. Preliminary Business

1.1 Call to Order-5:00 p.m.

President Bautista called the meeting to order at 5:02 p.m.

1.2 Pledge of Allegiance

President Bautista led the flag salute.

1.3 Roll Call

Trustee Torres called the roll, all present.

2. Approval of the Agenda

2.1 Agenda corrections, additions, and modifications.

There were no corrections or additions to the agenda.

2.2 Approval of the Agenda

Staff recommends approval of the agenda, as presented.

Motion by Eleanor Torres, second by Linda Armas.

Final Resolution: Motion Carries

Yes: Eleanor Torres, Edith Martinez-Cortes, Linda Armas, Cassandra Bautista, Kristine Anderson

3. Open Session 5:00

3.1 Public Comment Procedures for receiving communication from the public on topics that fall under the subject jurisdiction of the Governing Board. 1. Special Board Meeting - A member of the public may address the Governing Board on any item(s) on the agenda. (Each person speaking may not exceed a total of three minutes on each item). The speaker may choose to speak during public comment or at the time of the agenda item prior to board consideration. These presentations are limited to three minutes or a total of twenty minutes. There were no public comments.

4. Information/Discussion

4.1 Effective Governance Workshop/Governance Handbook

Angelina Pride, Facilitator for California School Board Association, led the board in the effective governance workshop. Ms. Pride touched on the topics of building a stronger team. The workshop will continue on Wednesday, February 10, 2021.

5. Adjournment

5.1 Adjournment

President Bautista adjourned the meeting at 8:07 p.m.

Approved on this 17th day of March, 2021.

John Puglisi, Ph.D., Secretary

Date

Eleanor Torres, Clerk of the Board

Date

10.4



Agenda Item Details

Meeting	Mar 17, 2021 - RSD Regular Board Meeting
Category	10. Consent
Subject	10.4 Approval of the Minutes of the Special Board Meeting of February 10, 2021
Access	Public
Type	Action, Minutes
Minutes	View Minutes for Feb 10, 2021 - Rio School District Special Board Meeting

Public Content

Speaker:

Rationale:

[MinSpec021021.pdf \(48 KB\)](#)

Administrative Content

Executive Content



**Rio School District
Minutes
Special Board Meeting
February 10, 2021
Rio School District
1800 Solar Drive
Oxnard, CA 93030
Open Session: 5:00 p.m.**

Members present

Eleanor Torres, Edith Martinez-Cortes, Linda Armas, Cassandra Bautista, Kristine Anderson

1. Preliminary Business

1.1 Call to Order-5:00 p.m.

President Bautista opened the meeting at 5:01 p.m.

1.2 Pledge of Allegiance

President Bautista led the flag salute.

1.3 Roll Call

Trustee Torres called the roll, all present.

2. Approval of the Agenda

2.1 Agenda corrections, additions, and modifications.

There were no additions or corrections to the agenda.

2.2 Approval of the Agenda

Staff recommends approval, as presented.

Motion by Eleanor Torres, second by Cassandra Bautista.

Final Resolution: Motion Carries

Yes: Eleanor Torres, Edith Martinez-Cortes, Linda Armas, Cassandra Bautista, Kristine Anderson

3. Open Session 5:00

3.1 Public Comment Procedures for receiving communication from the public on topics that fall under the subject jurisdiction of the Governing Board. 1. Special Board Meeting - A member of the public may address the Governing Board on any item(s) on the agenda. (Each person speaking may not exceed a total of three minutes on each item). The speaker may choose to speak during public comment or at the time of the agenda item prior to board consideration. These presentations are limited to three minutes or a total of twenty minutes. There were no public comments.

4. Information/Discussion

4.1 Effective Governance Workshop/Governance Handbook

Angelina Pride continued the work with the Governing Board and finalized the Governance Handbook. Input was received by all. Ms. Pride will submit a draft for all to review and will brought back for approval at a later scheduled board meeting.

5. Adjournment

5.1 Adjournment

President Bautista adjourned the meeting at 8:22 p.m.

Approved on this 17th day of March, 2021.

John Puglisi, Ph.D., Secretary

Date

Eleanor Torres, Clerk of the Board

Date

10.5

**Agenda Item Details**

Meeting	Mar 17, 2021 - RSD Regular Board Meeting
Category	10. Consent
Subject	10.5 Approval of the Minutes of the Regular Meeting of February 17, 2021
Access	Public
Type	Action (Consent), Minutes

Public Content

Speaker:

Rationale:

Min021721.pdf (65 KB)

Administrative Content**Executive Content**

Our adopted rules of Parliamentary Procedure, Robert's Rules, provide for a consent agenda listing several items for approval of the Board by a single motion. Most of the items listed under the consent agenda have gone through Board subcommittee review and recommendation. Documentation concerning these items has been provided to all Board members and the public in advance to assure an extensive and thorough review. Items may be removed from the consent agenda at the request of any board member.



**Rio School District
Minutes
Regular Board Meeting
February 17, 2021
Rio School District
1800 Solar Drive
Oxnard, CA 93030
Closed Session: 5:00 p.m.
Open Session: 6:00 p.m.**

Members present

Eleanor Torres, Edith Martinez-Cortes, Linda Armas, Cassandra Bautista, Kristine Anderson

1. Open Session 5:00 p.m.

Procedural: 1.1 Call to Order

President Bautista opened the meeting at 5:00 p.m.

1.2 Pledge of Allegiance

President Bautista led the flag salute.

1.3 Roll Call

Trustee Torres called the roll, all present.

2. Approval of the Agenda

2.1 Agenda Correction, Additions, Modifications

Trustee Torres tabled Items 4.5 Public Employee Performance Evaluation [Gov. Code 54967] Title: Staffing 2020/2021 and Superintendent's Evaluation and Item 9.9 Discuss Potential Request for Proposals (RFP) from private law firms to provide legal services to the District (Board Bylaw 9124) and information an RFP should include; also pulled for discussion 10.9 Approval of the Bond Counsel Agreement with Parker & Covert legal services for the upcoming CFD #1 Refunding.

2.2 Approval of the Agenda

Staff recommends approval as amended.

Motion by Eleanor Torres, second by Kristine Anderson.

Final Resolution: Motion Carries

Yes: Eleanor Torres, Edith Martinez-Cortes, Linda Armas, Cassandra Bautista, Kristine Anderson

3. Public Comment-Closed Session

3.1 Public Comment (Closed Session) The public may address the Board concerning items that are scheduled for discussion during the closed session only. These presentations are limited to three minutes each, or a total of fifteen minutes in all.
There were no public comments.

President Bautista adjourned the meeting into closed session at 5:05 p.m. and informed the public that due to the large closed session items they would be reconvening at approximately 6:15 p.m.

4. Closed Session

4.1 CONFERENCE WITH REAL PROPERTY NEGOTIATORS Property: 2715 E. Vineyard Avenue, Oxnard, CA 93036 (APN: 132-0-052-175) Agency Negotiator: Dr. John Puglisi, Superintendent; Joel Kirschenstein, Sage Realty Group; Jeff Hoskinson, AALRR Negotiating Parties: TBD Under Negotiation: Price and Terms of Payment

4.2 CONFERENCE WITH REAL PROPERTY NEGOTIATORS Property: 3410 N. Rose Avenue, Oxnard, CA (APN: 144-0-11-225) Agency Negotiator: Dr. John Puglisi, Superintendent; Joel Kirschenstein, Sage Realty Group; Jeff Hoskinson, AALRR Negotiating Parties: KMS Industries, Inc. Under Negotiation: Price and Terms of Payment for Amendment

4.3 Conference with Labor Negotiators [Government Code 54957.6] Agency designated representatives: RSD Negotiating Team; Employee Organization: California School Employee's Association and Rio Teachers' Association

4.4 Public Employee Discipline/Dismissal/Release [Government Code 54957]

4.5 Public Employee Performance Evaluation [Government Code 54957] Title: Staffing 2020/2021 and Superintendent's Evaluation

This item was tabled to the next regularly scheduled meeting.

5. Reconvene Open Session 6:00 p.m.

5.1 Report of Closed Session

President Bautista reconvened the 6:45 p.m. The following action took place during closed session:

The board by unanimous vote of all its members approved Amendment No. 2 to the Purchase and Sale agreement with KMS Industries, Inc., the details of which will be made available upon request once approved by the Seller. The board took no relative action relative to item 4.1.

On a vote of 5-0, the board took action to non-reelect and to provide notice pursuant to EC 44929.21 to employee numbers 3327, 3559, and 1404.

On a vote of 5-0, the board took action to provide notices of release pursuant to EC 44954 to employee numbers 3756, 3274, 3695, 3696, 3775, 3783, and 3693.

The Governing Board directed counsel to provide notice of possible reassignment to an administrator for the 2021/2022 school year, by unanimous vote.

6. Public Hearing

6.1 2020/2021 RTA TO RSD Sunshine Proposals for Reopener Negotiations

President Bautista opened the public hearing at 6:47 p.m. As there were public comments, President Bautista closed the public hearing at 6:48 p.m.

6.2 2020/2021 RSD to RTA Sunshine Proposals for Reopener Negotiations

President Bautista opened the meeting at 6:48 p.m. As there were no comments, President Bautista closed the public hearing at 6:48 p.m.

7. Communications

7.1 Acknowledgement of Correspondence to the Board

No written correspondence was submitted.

7.2 Board Member Reports

Board member reports were heard from Trustee Torres, Anderson and President Bautista.

7.3 Organizational Reports-RTA/CSEA/Other

Organizational reports were heard from Marisela Valdez, President, Rio Teachers' Association and Patrick Radford, Vice President, CSEA.

7.4 Superintendent Report

Superintendent Puglisi informed the board that he is working with the Ventura County Office of Education to expedite the distribution of vaccines. Also our district is currently complying with guidelines set in order to bring students on campus. Information will be coming in regards to the revised guidelines to reopen school sites.

7.5 Public Comment-Board meetings are meetings of the Governing Board held in public, not public forums, and will be held in a civil, orderly and respectful manner. All public comments or questions should be addressed to the board through the board president. To assure an orderly meeting and an equal opportunity for each speaker, persons wishing to address the Board must fill out a speaker card. Cards are available at the meeting and on the District website. Cards must be submitted to the Secretary or Clerk of the Board. The speaker may choose to speak during public comment or at the time of the agenda item prior to board consideration. The Governing Board may place limitations on the total time to be devoted to each topic if it finds that the number of speakers would impede the Board's ability to conduct its business in a timely manner. Procedures for receiving communication from the public on topics that fall under the subject jurisdiction of the Governing Board. A member of the public may address the Governing Board on any item(s) on the agenda or non-agenda items. Each person speaking may not exceed a total of three minutes on each item. The speaker may choose to speak during public comment or at the time of the agenda item prior to board consideration. These presentations are limited to three minutes or a total of twenty minutes.

There were no public comments.

8. Information

8.1 Business Services Report

Wael Saleh, Assistant Superintendent of Business Services, introduced Lacey Piper, Director of Child Nutrition. Ms. Piper provided an update on COVID numbers, safety, community feeding, distance only learning and Virtual Cook Nights.

8.2 Educational Services Report

Oscar Hernandez, Assistant Superintendent of Educational Services, updated the board on the makeup of the Grading Committee. The committee met twice last week and an item will be discussed in action.

8.3 School and Systems Improvement Updates

Carol Bernal, Ed.D., Assistant Superintendent of School and Systems Improvement, presented an enrollment and COVID update.

We have had more positive and close contact cases but none of the cases have been work related.

8.4 First Reading of CSBA Board Policy Revisions

Superintendent Puglisi presented another round of board policies that will be brought for final reading at the next regularly scheduled meeting.

9. Discussion/Action

9.1 RESOLUTION #2021/49 - AUTHORIZATION OF PUBLIC SALE OF 2715 EAST VINEYARD AVENUE PROPERTY AND ESTABLISHING POLICY AND PROCEDURES FOR RECEIPT OF PROPOSALS FOR PURCHASE, LEASE, OR EXCHANGE

Staff recommends approval.

Motion by Eleanor Torres, second by Cassandra Bautista.

Final Resolution: Motion Carries

Yes: Eleanor Torres, Edith Martinez-Cortes, Linda Armas, Cassandra Bautista, Kristine Anderson

9.2 2020/2021 RTA Sunshine Proposals for Reopener Negotiations

It is recommended the board take action and approve the 2020/2021 RTA Sunshine Proposals as submitted.

Motion by Linda Armas, second by Cassandra Bautista.

Final Resolution: Motion Carries

Yes: Eleanor Torres, Edith Martinez-Cortes, Linda Armas, Cassandra Bautista, Kristine Anderson

9.3 2020/2021 RSD Sunshine Proposals for Reopener Negotiations

It is recommended the board take action and approve the RSD sunshine proposals as submitted.

Motion by Linda Armas, second by Eleanor Torres.

Final Resolution: Motion Carries

Yes: Eleanor Torres, Edith Martinez-Cortes, Linda Armas, Cassandra Bautista, Kristine Anderson

9.4 Approval of BB9270 Board Bylaw Policy

Staff recommends board approval of board bylaw BB9270.

Motion by Cassandra Bautista, second by Edith Martinez-Cortes.

Final Resolution: Motion Carries

Yes: Eleanor Torres, Edith Martinez-Cortes, Linda Armas, Cassandra Bautista, Kristine Anderson

9.5 Second and Final Reading of Trimester 2 and 3 2020/2021 Grading Policy

The Governing Board discussed and shared opinions. **No action will be taken at this time.**

9.6 Review/Approve District Credit Card Guidelines

The Governing Board discussed changes and revisions to the Credit Card policies. An information item on a revised policy will be brought to the board at the next regularly scheduled meeting.

9.7 Approval of new Tech Wall at the Rio Vista Middle School gymnasium that is an antimicrobial COVID 19 treated wall surface.

It is recommended that the Board approve Tech Wall to install a new antimicrobial COVID 19 treated wall surface at Rio Vista Middle School gymnasium.

Motion by Cassandra Bautista, second by Edith Martinez-Cortes.

Final Resolution: Motion Carries

Yes: Eleanor Torres, Edith Martinez-Cortes, Linda Armas, Cassandra Bautista, Kristine Anderson

9.8 Approval of Resolution No. 20/21-47 of the Board of Trustees of the Rio School District as the Legislative Body of Community Facilities District No. 1 of the Rio Elementary School District, Authorizing the Issuance of Special Tax Refunding Bonds.

Staff recommends approval.

Motion by Cassandra Bautista, second by Linda Armas.

Final Resolution: Motion Carries

Yes: Eleanor Torres, Edith Martinez-Cortes, Linda Armas, Casandra Bautista, Kristine Anderson

9.9 Discuss potential Request for Proposals (RFP) from private law firms to provide legal services to the District (Board Bylaw 9124), and information an RFP should include
This item was tabled.

10. Consent

10.1 Approval of the Consent Agenda

Staff recommends approval as amended.

Motion by Eleanor Torres, second by Cassandra Bautista.

Final Resolution: Motion Carries

Yes: Eleanor Torres, Edith Martinez-Cortes, Linda Armas, Casandra Bautista, Kristine Anderson

10.2 Approval of the Minutes of the Regular Board Meeting of January 20, 2021

10.3 Approval of the Donation Report

10.4 February 2021 Personnel Report

10.5 Authorization of Teaching Assignment - Multiple Subjects

10.6 Ratification of the Commercial Warrant for January 4, 2021 through February 3, 2021

10.7 2nd Quarter Williams Ventura County Office of Education Activity Report

10.8 Approval of Annual Parent Engagement Policies for all Nine Rio Schools

10.9 Approval of the Bond Counsel Agreement with Parker & Covert legal services for the upcoming CFD 1 Refunding.

It is recommended that the Board approve the Agreement for Bond Counseling from Parker & Covert for the upcoming CFD 1 Refunding.

Motion by Eleanor Torres, second by Cassandra Bautista.

Final Resolution: Motion Carries

Yes: Eleanor Torres, Edith Martinez-Cortes, Linda Armas, Cassandra Bautista, Kristine Anderson

10.10 Approval of COVID 19 Facilities Preparation Work at Rio Real that includes Administrative Office Repairs and Teacher's Workroom #12 Upgrades

10.11 Approval of Resolution 20/21-38 for the Notice of Completion for Project #20-05L, New Staff Parking Lot at Rio Lindo by Civic Construction Associates

10.12 Approval of Resolution No. 20/21-44 for the Notice of Completion of the Kiln Enclosure by Hughes General Engineering at Rio Del Sol.

10.13 Approval of Resolution No. 20/21-45 for the Notice of Completion of Bid Package #1 Site Earthwork, Concrete and CMU, RSD Project #19-0068-015 Rio Del Sol, STEAM Academy, Building C, by MVC Enterprises, Inc. dba Moreno Valley Construction

10.14 Approval of Resolution No. 20/21-46 for the Notice of Completion of Bid Package #14 Electrical, Low Voltage Systems, Lighting, Fire and Intrusion Detection Systems, Intercommunication Systems, Computer Networking Systems and Elevator at Rio Del Sol by Venco Electric, Inc.

11. Organizational Business

11.1 Future Items for Discussion

11.2 Future Meeting Dates: March 17, 2021

12. Adjournment

12.1 Adjournment

President Bautista adjourned the meeting at 9:33 p.m.

Approved on this 17th day of March, 2021.

John Puglisi, Ph.D., Secretary

Date

Eleanor Torres, Clerk of the Board

Date

10.6

**Agenda Item Details**

Meeting	Mar 17, 2021 - RSD Regular Board Meeting
Category	10. Consent
Subject	10.6 Approval of the Minutes of the Special Board Meeting of March 3, 2021
Access	Public
Type	Action (Consent), Minutes
Minutes	View Minutes for Mar 3, 2021 - Rio School District Special Board Meeting

Public Content

Speaker:

Rationale:

MinSpec030321.pdf (48 KB)

Administrative Content**Executive Content**

Our adopted rules of Parliamentary Procedure, Robert's Rules, provide for a consent agenda listing several items for approval of the Board by a single motion. Most of the items listed under the consent agenda have gone through Board subcommittee review and recommendation. Documentation concerning these items has been provided to all Board members and the public in advance to assure an extensive and thorough review. Items may be removed from the consent agenda at the request of any board member.



**Rio School District
Minutes
Special Board Meeting
February 10, 2021
Rio School District
1800 Solar Drive
Oxnard, CA 93030
Open Session: 5:00 p.m.**

Members present

Eleanor Torres, Edith Martinez-Cortes, Linda Armas, Cassandra Bautista, Kristine Anderson

1. Preliminary Business

1.1 Call to Order-4:30 p.m.

President Bautista called the meeting to order at 4:34 p.m.

1.2 Pledge of Allegiance

Carlo Godoy led the flag salute.

1.3 Roll Call

Trustee Torres called the roll, all present.

2. Approval of the Agenda

2.1 Agenda corrections, additions, and modifications.

There were no corrections or modifications to the agenda.

2.2 Approval of the Agenda

Staff recommends approval of the agenda as presented.

Motion by Eleanor Torres, second by Edith Martinez-Cortes.

Final Resolution: Motion Carries

Yes: Eleanor Torres, Edith Martinez-Cortes, Linda Armas, Casandra Bautista, Kristine Anderson

3. Public Comments/Closed Session

3.1 Public Comment (Closed Session) The public may address the Board concerning items that are scheduled for discussion during the closed session only. These presentations are limited to three minutes each, or a total of fifteen minutes in all.

There were no public comments.

President Bautista adjourned the meeting into closed session at 4:37 p.m.

4. Closed Session

4.1 CONFERENCE WITH REAL PROPERTY NEGOTIATORS Property: 3410 N. Rose Avenue, Oxnard, CA (APN: 144-0-11-225) Agency Negotiator: Dr. John Puglisi, Superintendent; Joel Kirschenstein, Sage Realty Group; Jeff Hoskinson, AALRR Negotiating Parties: KMS Industries, Inc. Under Negotiation: Price and Terms of Payment for Amendment

4.2 Conference with Labor Negotiators [Government Code 54957.6] Agency designated representatives: RSD Negotiating Team; Employee Organization: California School Employee's Association and Rio Teachers' Association

5. Open Session

5.1 Reconvene/Report of Closed Session

President Bautista reconvened the meeting into open session at 5:43 p.m.

The following action took place during closed session:

The Board met in Closed Session relative to Item 4.1, real property negotiations relative to Rose Avenue Property. As part of that discussion, the Board by unanimous roll-call vote of all of its members approved proposed terms for an Amendment No. 2 to the Purchase and Sale agreement, and authorized the Superintendent to finalize and execute an Amendment consistent with such terms. The details of the Amendment will be made available upon request once approved by the Seller.

6. Adjournment

6.1 Adjournment

President Bautista adjourned the meeting at 5:43 p.m.

Approved on this 17th day of March, 2021.

John Puglisi, Ph.D., Secretary Date

Eleanor Torres, Clerk of the Board Date

10.7



Agenda Item Details

Meeting Mar 17, 2021 - RSD Regular Board Meeting

Category 10. Consent

Subject 10.7 Approval of the Donation Report

Access Public

Type Action (Consent)

Recommended Action Staff recommends approval of the Donation Report.

Public Content

Speaker: Superintendent Puglisi

Rationale:

It is recommended the Governing Board accepts the following donations:

Site	Donor	Use of Donation	Amount
RRE	Lifetouch	Teacher Incentives	\$105.43

Administrative Content

Executive Content

Our adopted rules of Parliamentary Procedure, Robert's Rules, provide for a consent agenda listing several items for approval of the Board by a single motion. Most of the items listed under the consent agenda have gone through Board subcommittee review and recommendation. Documentation concerning these items has been provided to all Board members and the public in advance to assure an extensive and thorough review. Items may be removed from the consent agenda at the request of any board member.

10.8



Agenda Item Details

Meeting	Mar 17, 2021 - RSD Regular Board Meeting
Category	10. Consent
Subject	10.8 March 2021 Personnel Report
Access	Public
Type	Action (Consent)
Recommended Action	It is recommended the board take action and approve the March 2021 Personnel Report as presented.
Goals	Goal 5-Recruit, hire, train, and retain exemplary employees who are caring, committed, collaborative, creative and critical thinkers.

Public Content

Speaker: Carolyn Bernal

Rationale: The March 2021 Personnel Report is presented for approval.

PERS Report - March 17, 2021.pdf (59 KB)

Administrative Content

Executive Content

Our adopted rules of Parliamentary Procedure, Robert's Rules, provide for a consent agenda listing several items for approval of the Board by a single motion. Most of the items listed under the consent agenda have gone through Board subcommittee review and recommendation. Documentation concerning these items has been provided to all Board members and the public in advance to assure an extensive and thorough review. Items may be removed from the consent agenda at the request of any board member.

RIO SCHOOL DISTRICT
March 17, 2021

Certificated Personnel Report

Certificated Resignation:

King, Rebecca, SAI Teacher, Rio Plaza, (1.0) FTE, effective 06/17/2021
Douglas, Melissa, SAI Teacher, Rio del Sol, (1.0) FTE, effective 06/17/2021
Parker, Megan, Elementary School Teacher, (2020/2021 LOA) (1.0) FTE, effective 06/17/2021
Riggs, Katie, Elementary School Teacher, (2020/2021 LOA) (1.0) FTE, effective 06/17/2021

Certificated Management Resignation:

Bernal, Carolyn, Assistant Superintendent School and Systems Improvement, District Office, (1.0) FTE, effective 06/30/2021

Certificated Retirement:

Sheppard, Martha, Elementary School Teacher, Rio Plaza. (1.0) FTE, effective 06/17/2021

Certificated Leave of Absence:

Lauer, Meghan, Elementary School Teacher, LOA, (1.0) FTE, effective 2021/2022 school year
Stewart, Shaylee, Elementary School Teacher, LOA, (1.0) FTE, effective 2021/2022 school year
Schuster, Lauren, SAI Teacher, 80% LOA/0.20 FTE, effective 2021/2022 school year
Howell-Avila, Patricia, Elementary School Teacher, 40% LOA/0.60 FTE, effective 2021/2022 school year
Juarez, Sara, Elementary School Teacher, 60% LOA/0.40% FTE, effective 2021/2022 school year

Certificated Returning from Leave of Absence:

Cocking, Amanda, Elementary School Teacher, (1.0) FTE, effective 2021/2022 school year
Serrano, Jessica, Middle School Teacher, (1.0) FTE, effective 2021/2022 school year

Classified Personnel Report

Classified Leave of Absence:

Gonzales, Myrna, Campus Supervision Assistant, (4.33) hours, Rio Del Mar, effective 3/1/21 - 3/4/21.
Ramos, Chloe, Instructional Assistant/SPED, Rio Del Mar. (.40) Leave of Absence effective 4/15/21 - 5/14/21.

Classified Promotion:

Martinez, Veronica, from Food Service Worker I, (3) hours & (2) hours, Rio Lindo to Food Service Worker II, (5.5) hours, Rio Lindo, effective 3/15/21

Classified Ratification of Employment:

Martinez, Karina, Student & Family Support Specialist, (5) hours, Rio Del Mar, effective 3/1/21.

Classified Retirement:

Parks, Monika, Food Service Worker I, (2) hours, Rio Plaza, effective 2/31/21.

Classified Voluntary Transfer:

Flores, Xochitl, from Food Service Worker II, (5.5) hours, Rio Vista, to Food Service Worker II, (5.5) hours, Rio Lindo, effective 3/15/21.

10.9



Agenda Item Details

Meeting	Mar 17, 2021 - RSD Regular Board Meeting
Category	10. Consent
Subject	10.9 Ratification of the Commercial Warrant for February 3, 2021 through March 5, 2021
Access	Public
Type	Action
Fiscal Impact	Yes
Dollar Amount	2,492,317.38
Budgeted	Yes
Budget Source	Various Funds as listed below.
Recommended Action	It is recommended that the Ratification of the Commercial Warrant be approved for the period February 3, 2021 through March 5, 2021.

Public Content

Speaker:
Wael Saleh, Assistant Superintendent, Business Services

Rationale:

The District processed payments to vendors since the last meeting of the Governing Board for a total amount of \$2,492,317.38 which includes processing payments for all funds of the District for the period February 3, 2021 through March 5, 2021 in the following amounts:

Fund 010 General Fund	\$1,561,803.97
Fund 130 Cafeteria Fund	\$406,783.20
Fund 212 Building Fund, Measure L	\$177,195.05
Fund 251 Capital Facilities - Residential	\$10,331.00
Fund 490 Capital Projects Fund for Blen	\$336,585.92
Less Unpaid Tax Liability	<u>(\$381.76)</u>
Total:	<u>\$2,492,317.38</u>

Monthly Board Report of Checks 2-3 to 3-5-21.pdf (118 KB)

Administrative Content

Executive Content

Checks Dated 02/03/2021 through 03/05/2021

Check Number	Check Date	Pay to the Order of	Fund	Expensed Amount	Check Amount
5009039795	02/04/2021	Lam, Phaedra	010	138.03	
5009039796	02/04/2021	360 Degree Customer Inc.	010	1,462.07	
5009039797	02/04/2021	AMAZON CAPITAL SERVICES	010	1,124.95	
5009039798	02/04/2021	Atkinson, Andelson, Loya, Ruud & Romo	010	23,636.25	
5009039801	02/04/2021	William Venegas Hip Hop Mindset	010	2,170.00	
5009039802	02/04/2021	GREEN TREE CARE	010	1,100.00	
5009039803	02/04/2021	KONICA MINOLTA PREMIER FINANCE	010	2,054.11	
5009039804	02/04/2021	Michelle Reyes	010	60.00	
5009039809	02/04/2021	Wireless CCTV LLC	010	3,000.00	
5009039811	02/09/2021	Vazquez, Sarah E	010	240.00	
5009039812	02/09/2021	AMAZON CAPITAL SERVICES	010	1,603.94	
5009039813	02/09/2021	AT&T	010	3,075.20	
5009039814	02/09/2021	AT&T	010	68.86	
5009039815	02/09/2021	AT&T	010	227.53	
5009039816	02/09/2021	Yolanda M. Benitez	010	12,192.59	
5009039817	02/09/2021	California American Water	010	5,563.02	
5009039818	02/09/2021	C D W GOVERNMENT, INC.	010	5,044.00-	
5009039819	02/09/2021	CITY OF OXNARD	010	16,774.60	
5009039820	02/09/2021	CMRS-FP	010	15,000.00	
5009039821	02/09/2021	De Lage Landen Financial Servi ces, Inc.	010	203.65	
5009039822	02/09/2021	Diane DeLaurantis	010	1,100.00	
5009039824	02/09/2021	SOUTHERN CALIF. EDISON	010	13,569.90	
5009039825	02/09/2021	FEDEX	010	52.29	
5009039826	02/09/2021	Frontier Communications	010	56.59	
5009039827	02/09/2021	GREATAMERICA FINANCIAL SVCS	010	309.16	
5009039830	02/09/2021	KONICA MINOLTA PREMIER FINANCE	010	4,839.99	
5009039831	02/09/2021	Marcus Lopez	010	300.00	
5009039833	02/09/2021	Maxim Healthcare Staffing	010	1,152.00	
5009039834	02/09/2021	Open Up Resources	010	482.63	
5009039837	02/09/2021	Steve Sunnarborg	010	1,075.00	
5009039840	02/09/2021	Broadview Networks	010	8,757.82	
5009039842	02/16/2021	Francisco Casmali Lopez	010	560.00	
5009039843	02/16/2021	Aragon, Kathryn	010	12.88	
5009039844	02/16/2021	Yurof, Josefina	010	121.73	
5009039845	02/16/2021	Gibson, Brian D	010	40.92	
5009039846	02/16/2021	Romero, Teresa	010	49.00	
5009039847	02/16/2021	Daugherty, Stephen A	010	7.40	
5009039848	02/16/2021	Mandujano Diaz, Veronica	010	5.12	
5009039849	02/16/2021	Sanchez, Natacha	010	52.50	
5009039850	02/16/2021	Cordova, Ralph	010	154.02	
5009039851	02/16/2021	Stephenson, Rachel L	010	87.88	
5009039852	02/16/2021	Ehret, Kristin M	010	128.43	
5009039853	02/16/2021	Pollard, Andrea	010	5.98	

The preceding Checks have been issued in accordance with the District's Policy and authorization of the Board of Trustees. It is recommended that the preceding Checks be approved.

ESCAPE ONLINE

Page 1 of 7

Checks Dated 02/03/2021 through 03/05/2021

Check Number	Check Date	Pay to the Order of	Fund	Expensed Amount	Check Amount
5009039854	02/16/2021	Cardenas, Viviana	010	23.33	
5009039855	02/16/2021	Franz, Diane F	010	236.52	
5009039856	02/16/2021	360 Degree Customer Inc.	010	50,956.80	
5009039858	02/16/2021	Assistance League School	010	11,500.00	
5009039859	02/16/2021	Aswell Trophy	010	3,301.11	
5009039860	02/16/2021	AT&T	010	2,107.02	
5009039861	02/16/2021	Blick Art Materials	010	2,922.82	
5009039862	02/16/2021	Chumash Indian Museum	010	50.00	
5009039863	02/16/2021	CITY OF OXNARD	010	6,924.60	
5009039864	02/16/2021	Stephen Clark	010	1,200.00	
5009039865	02/16/2021	SCHOOL SPECIALTY	010	48,912.96	
5009039866	02/16/2021	Diane DeLaurantis	010	1,300.00	
5009039867	02/16/2021	Demco	010	8,604.49	
5009039869	02/16/2021	EBS HEALTHCARE	010	6,375.00	
5009039870	02/16/2021	SOUTHERN CALIF. EDISON	010	2,938.12	
5009039871	02/16/2021	FOLLETT SCHOOL SOLUTIONS, INC.	010	2,306.96	
5009039872	02/16/2021	Fry's Electronics customer #70893	010	486.59	
5009039873	02/16/2021	THE GAS COMPANY	010	804.34	
5009039874	02/16/2021	HARRIS WATER CONDITIONING	010	122.58	
5009039875	02/16/2021	IXL Learning	010	1,079.00	
5009039876	02/16/2021	Kajeet, Inc	010	163,788.20	
5009039877	02/16/2021	Melinda Zapata Kalainoff	010	918.75	
5009039878	02/16/2021	Karen Schnee	010	4,300.00	
5009039879	02/16/2021	LAKESHORE	010	4,241.77	
5009039881	02/16/2021	LAZEL	010	4,332.00	
5009039882	02/16/2021	Live Scan Ventura	010	104.00	
5009039883	02/16/2021	Lynne M Slidders	010	1,587.50	
5009039884	02/16/2021	M/M Mechanical Inc.	010	2,433.42	
5009039886	02/16/2021	Maxim Healthcare Staffing	010	14,304.00	
5009039887	02/16/2021	Myers, Widders, Gibson, Jones	010	130.94	
5009039888	02/16/2021	OTC BRANDS, INC.	010	229.43	
5009039889	02/16/2021	Overhead Door	010	250.00	
5009039891	02/16/2021	PARADISE CHEVROLET	010	635.14	
5009039892	02/16/2021	PEARSON	010	1,485.08	
5009039893	02/16/2021	PERMA BOUND	010	44.11	
5009039894	02/16/2021	PhiSiRA	010	4,000.00	
5009039896	02/16/2021	REALLY GOOD STUFF	010	2,739.36	
5009039897	02/16/2021	Rio School District	010	998.28	
5009039898	02/16/2021	Riverside Insights	010	939.86	
5009039899	02/16/2021	SCHOLASTIC	010	74.54	
5009039900	02/16/2021	Pacific OneSource, Inc STS education	010	44,113.12	
5009039901	02/16/2021	SECURE CONTENT SOLUTIONS	010	4,953.23	
5009039902	02/16/2021	Signature School Products	010	7,326.79	
5009039903	02/16/2021	Skechers USA Inc.	010	2,113.75	
5009039907	02/16/2021	VCOE Business	010	25,614.31	

The preceding Checks have been issued in accordance with the District's Policy and authorization of the Board of Trustees. It is recommended that the preceding Checks be approved.

ESCAPE ONLINE

Page 2 of 7

Checks Dated 02/03/2021 through 03/05/2021

Check Number	Check Date	Pay to the Order of	Fund	Expensed Amount	Check Amount
5009039908	02/16/2021	XEROX CORPORATION	010	4,784.86	
5009039909	02/18/2021	DEMSEY, FILLIGER & ASSOCIATES	010	500.00	
5009039910	02/18/2021	Georgia Kerns	010	2,261.49	
5009039911	02/18/2021	Garcia, Primitivo	010	38.71	
5009039912	02/18/2021	Mooney, Erin C	010	29.92	
5009039913	02/18/2021	Messecar, Fred H	010	32.47	
5009039914	02/18/2021	Zamudio, Aurora	010	31.51	
5009039915	02/18/2021	Morales, Stella M	010	173.34	
5009039916	02/18/2021	APPLIED BACKFLOW TECHNOLOGIES	010	1,300.00	
5009039917	02/18/2021	Aquarium of the Pacific	010	300.00	
5009039919	02/18/2021	BARON INDUSTRIES	010	240.21	
5009039921	02/18/2021	CCP Industries Inc.	010	989.53	
5009039922	02/18/2021	SCHOOL SPECIALTY	010	58.87	
5009039923	02/18/2021	COASTAL OCCUPATIONAL MEDICAL GROUP	010	220.00	
5009039924	02/18/2021	COGGS TIRE SERVICE	010	50.23	
5009039925	02/18/2021	edpuzzle	010	1,300.00	
5009039926	02/18/2021	Ewing Irrigation Products Inc	010	168.63	
5009039927	02/18/2021	Fence Factory	010	236.98	
5009039928	02/18/2021	FERGUSON FACILITIES SUPPLY	010	702.29	
5009039929	02/18/2021	FGL Environmental	010	560.00	
5009039930	02/18/2021	FRANKLIN TRUCK PARTS, INC.	010	18.96	
5009039931	02/18/2021	Haynes Education Center (NPS) Star Academy	010	765.00	
5009039932	02/18/2021	LAKESHORE	010	600.07	
5009039933	02/18/2021	MWG MESTMAKER & ASSOCIATES	010	160.00	
5009039934	02/18/2021	Nee Quaison Sackey	010	1,600.00	
5009039935	02/18/2021	Oxnard Union High School Distr ict	010	7,368.03	
5009039936	02/18/2021	Auto Plus Auto Parts	010	392.17	
5009039938	02/18/2021	Sam's Club Direct	010	344.33	
5009039939	02/18/2021	Crown Castle	010	2,227.09	
5009039941	02/18/2021	VENTURA COUNTY SELF-FUNDING AUTHORITY	010	11,919.00	
5009039943	02/18/2021	Ventura County Office of Education	010	270.00	
5009039944	02/18/2021	WORTHINGTON DIRECT, INC.	010	17,751.41	
5009039945	02/18/2021	Western Psychological Services	010	835.96	
5009039946	02/18/2021	XEROX CORPORATION	010	275.82	
5009039947	02/22/2021	CALIFORNIA BUSINESS BUREAU, IN C.	010	548.01	
5009039948	02/22/2021	Mandujano Diaz, Veronica	010	11.90	
5009039949	02/22/2021	Diane DeLaurantis	010	1,400.00	
5009039950	02/22/2021	DURBIANO FIRE EQUIPMENT, INC.	010	2,248.69	
5009039951	02/22/2021	EJL Inc. P.C.	010	5,750.00	
5009039952	02/22/2021	FERGUSON FACILITIES SUPPLY	010	3,124.81	
5009039953	02/22/2021	GIBBS INTERNATIONAL	010	884.63	
5009039954	02/22/2021	Golden State Alarms, Inc.	010	7,772.38	

The preceding Checks have been issued in accordance with the District's Policy and authorization of the Board of Trustees. It is recommended that the preceding Checks be approved.

ESCAPE ONLINE

Page 3 of 7

Checks Dated 02/03/2021 through 03/05/2021

Check Number	Check Date	Pay to the Order of	Fund	Expensed Amount	Check Amount
5009039955	02/22/2021	GOLDEN STATE COPIER & MAILING	010	618.50	
5009039956	02/22/2021	Grainger	010	480.84	
5009039957	02/22/2021	Green Thumb Nursery	010	659.58	
5009039958	02/22/2021	HENSON MUSIC STORE	010	1,347.95	
5009039959	02/22/2021	Hillyard	010	2,695.16	
5009039960	02/22/2021	House Sanitary Supply	010	640.95	
5009039961	02/22/2021	Kimball Midwest	010	217.34	
5009039962	02/22/2021	LRP PUBLICATIONS	010	39.27	
5009039963	02/22/2021	Nason's Lock & Safe Inc DBA Nasons Lock & Security	010	47.68	
5009039964	02/22/2021	O'Reilly Auto Parts	010	1,422.53	
5009039965	02/22/2021	PARKHOUSE TIRE, INC.	010	819.01	
5009039966	02/22/2021	Auto Plus Auto Parts	010	780.68	
5009039967	02/22/2021	PRAXAIR DISTRIBUTION INC	010	98.69	
5009039968	02/22/2021	SC FUELS	010	4,675.14	
5009039970	02/22/2021	Skechers USA Inc.	010	406.70	
5009039971	02/22/2021	Skillpath Seminars	010	248.00	
5009039972	02/22/2021	School Services Of California	010	720.00	
5009039973	02/22/2021	Steve Sunnarborg	010	1,425.00	
5009039974	02/22/2021	Traffic Safety Warehouse	010	1,077.50	
5009039975	02/22/2021	Traffic Technologies, LLC	010	634.65	
5009039976	02/22/2021	VC Metals Inc	010	44.87	
5009039977	02/22/2021	STEVE ZOLOTAS DBA WEST OAKS PEST CONTROL	010	2,712.00	
5009039978	02/22/2021	YAMA LAWNMOWER REPAIR	010	43.08	
5009039979	02/23/2021	William M Brown DBA B&B Services	010	8,727.29	
5009039980	02/23/2021	VERIZON WIRELESS	010	274.51	
5009039981	02/25/2021	AT&T	010	101.28	
5009039982	02/25/2021	SOUTHERN CALIF. EDISON	010	12,755.39	
5009039983	02/25/2021	Frontier Communications	010	475.06	
5009039984	02/25/2021	THE GAS COMPANY	010	2,682.47	
5009039985	02/25/2021	OFFICE DEPOT	010	3,247.63	
5009039986	02/25/2021	REPUBLIC ELEVATOR COMPNAY	010	385.00	
5009039987	02/25/2021	Sonitrol	010	1,309.20	
5009039988	02/25/2021	Southwest School & Office Supply	010	7,255.68	
5009039989	02/25/2021	T-Mobile	010	173.70	
5009039990	02/25/2021	UNITED WATER CONSERVATION DIST	010	3,001.85	
5009039994	03/01/2021	Aswell Trophy	010	742.30	
5009039996	03/01/2021	Diane DeLaurantis	010	1,450.00	
5009039997	03/01/2021	E J Harrison & Sons	010	8,299.46	
5009039998	03/01/2021	EBS HEALTHCARE	010	5,737.50	
5009039999	03/01/2021	Joanne Espinoza-Law	010	759.70	
5009040001	03/01/2021	THE GAS COMPANY	010	6,587.09	
5009040002	03/01/2021	HARRIS WATER CONDITIONING	010	53.38	
5009040003	03/01/2021	House Sanitary Supply	010	758.81	
5009040006	03/01/2021	Learning Priority, Inc	010	4,950.00	

The preceding Checks have been issued in accordance with the District's Policy and authorization of the Board of Trustees. It is recommended that the preceding Checks be approved.

ESCAPE ONLINE

Page 4 of 7

Checks Dated 02/03/2021 through 03/05/2021

Check Number	Check Date	Pay to the Order of	Fund	Expensed Amount	Check Amount
5009040007	03/01/2021	Live Scan Ventura	010	416.00	
5009040009	03/01/2021	Maxim Healthcare Staffing	010	13,670.40	
5009040010	03/01/2021	Nee Quaison Sackey	010	1,600.00	
5009040011	03/01/2021	OFFICE DEPOT	010	3,494.38	
5009040012	03/01/2021	Auto Plus Auto Parts	010	1,206.79	
5009040016	03/01/2021	Southwest School & Office Supply	010	622.39	
5009040017	03/01/2021	Studies Weekly	010	1,087.90	
5009040018	03/01/2021	Tax Deferred Services Corporate Office Suite 209	010	91,600.00	
5009040019	03/01/2021	Dr. Elizabeth Yeager	010	2,512.50	
5009040021	03/03/2021	HOME DEPOT CREDIT SERVICES	010	8,187.01	
5009040023	03/03/2021	Steve Sunnarborg	010	600.00	
5009040024	03/03/2021	U.S. Bank Corporate Payment Systems	010	14,600.00	
5009040025	03/03/2021	Wireless CCTV LLC	010	3,000.00	
5009040027	03/04/2021	Ramirez, Jisela	010	63.28	
5009040028	03/04/2021	Ramsey, Emily	010	19.50	
5009040029	03/04/2021	Facundo, Katherine A	010	300.00	
5009040030	03/04/2021	A-Z BUS SALES, INC.	010	784.10	
5009040031	03/04/2021	AMAZON.COM CORPORATE CREDIT	010	1,326.54	
5009040032	03/04/2021	Ann Marostica Ransom	010	225.00	
5009040033	03/04/2021	Aswell Trophy	010	120.46	
5009040034	03/04/2021	AT&T	010	68.78	
5009040035	03/04/2021	Brandon Lewis	010	2,360.77	
5009040036	03/04/2021	California Lutheran University CRLP	010	1,000.00	
5009040037	03/04/2021	CCTC	010	100.00	
5009040038	03/04/2021	COASTAL OCCUPATIONAL MEDICAL GROUP	010	90.00	
5009040039	03/04/2021	Document Tracking Service,	010	5,000.00	
5009040041	03/04/2021	Dual Language Education of New Mexico	010	485.00	
5009040042	03/04/2021	SOUTHERN CALIF. EDISON	010	11,701.01	
5009040043	03/04/2021	Educational Design, LLC	010	990.00	
5009040044	03/04/2021	Frontier Communications	010	54.30	
5009040045	03/04/2021	Global Equity Communications	010	3,037.50	
5009040046	03/04/2021	GREATAMERICA FINANCIAL SVCS	010	279.09	
5009040047	03/04/2021	GW School Supply	010	245.45	
5009040048	03/04/2021	William Venegas Hip Hop Mindset	010	2,100.00	
5009040049	03/04/2021	ISCEF	010	228.00	
5009040050	03/04/2021	KONICA MINOLTA BUSINESS SOLUTIONS USA, INC.	010	1,435.83	
5009040052	03/04/2021	Leaving the Village	010	95.00	
5009040053	03/04/2021	LRP PUBLICATIONS	010	763.50	
5009040055	03/04/2021	Rio School District	010	110.00	
5009040056	03/04/2021	SISC FINANCE	010	641,522.55	
5009040057	03/04/2021	Super Nature Adventures, LLC	010	8,500.00	
5009040060	03/04/2021	Tammy Van Fleet, PHD, BCBAD	010	2,362.50	

The preceding Checks have been issued in accordance with the District's Policy and authorization of the Board of Trustees. It is recommended that the preceding Checks be approved.

ESCAPE ONLINE

Page 5 of 7

Checks Dated 02/03/2021 through 03/05/2021

Check Number	Check Date	Pay to the Order of	Fund	Expensed Amount	Check Amount
5009040062	03/04/2021	XEROX CORPORATION	010	626.86	
5009039806	02/04/2021	Skechers USA Inc.	Cancelled		1,073.30 *
Cancel	1	1,073.30			
Total Number of Checks			218	1,561,803.97	
5009039799	02/04/2021	CDE/CASHIER'S OFFICE	130	2,280.00	
5009039800	02/04/2021	Driftwood Dairy, Inc.	130	34,339.37	
5009039805	02/04/2021	Tri County Bread Service	130	1,203.01	
5009039807	02/04/2021	SYSCO VENTURA, INC.	130	34,223.22	
5009039810	02/09/2021	Gutierrez, Rosaizela M	130	5.99	
5009039823	02/09/2021	Driftwood Dairy, Inc.	130	3,981.96	
5009039839	02/09/2021	THE BERRY MAN, INC.	130	66,011.50	
5009039857	02/16/2021	Allied Avocados & Citrus Inc	130	1,656.00	
5009039868	02/16/2021	Driftwood Dairy, Inc.	130	7,576.59	
5009039880	02/16/2021	Laubacher Farms, inc	130	4,720.00	
5009039890	02/16/2021	P & R Paper Supply Co., Inc.	130	3,491.96	
5009039895	02/16/2021	Puretec Industrial Water	130	197.93	
5009039905	02/16/2021	SYSCO VENTURA, INC.	130	26,540.39	
5009039906	02/16/2021	THE BERRY MAN, INC.	130	10,919.25	
5009039908	02/16/2021	XEROX CORPORATION	130	156.29	
5009039956	02/22/2021	Grainger	130	247.66	
5009039968	02/22/2021	SC FUELS	130	362.74	
5009039985	02/25/2021	OFFICE DEPOT	130	1,638.90	
5009039991	02/25/2021	VENTURA REFRIGERATION SALES & SERVICE	130	504.61	
5009040005	03/01/2021	Laubacher Farms, inc	130	3,612.00	
5009040014	03/01/2021	Puretec Industrial Water	130	399.00	
5009040020	03/03/2021	Allied Avocados & Citrus Inc	130	4,439.00	
5009040022	03/03/2021	Tri County Bread Service	130	6,326.43	
5009040026	03/04/2021	THUSHARI ARIYARATNA	130	34.50	
5009040040	03/04/2021	Driftwood Dairy, Inc.	130	60,754.01	
5009040051	03/04/2021	Laubacher Farms, inc	130	3,816.00	
5009040054	03/04/2021	Tri County Bread Service	130	3,495.11	
5009040058	03/04/2021	SYSCO VENTURA, INC.	130	85,140.44	
5009040059	03/04/2021	THE BERRY MAN, INC.	130	38,709.34	
Total Number of Checks			29	406,783.20	
5009039808	02/04/2021	Tech-Wall	212	3,983.70	
5009039818	02/09/2021	C D W GOVERNMENT, INC.	212	6,181.75	
5009039828	02/09/2021	JPI Development Group Inc.	212	7,000.00	
5009039829	02/09/2021	Kiwitt General Building	212	4,450.00	
5009039832	02/09/2021	M/M Mechanical Inc.	212	597.63	
5009039885	02/16/2021	School Specialty	212	4,787.79	
5009039904	02/16/2021	Sweetwater	212	68,037.49	
5009039918	02/18/2021	A4E	212	4,408.75	
5009039937	02/18/2021	Reed Mechanical Systems Inc.	212	47,532.15	
5009039940	02/18/2021	Tierney Brothers, Inc	212	4,651.57	

The preceding Checks have been issued in accordance with the District's Policy and authorization of the Board of Trustees. It is recommended that the preceding Checks be approved.

ESCAPE ONLINE

Page 6 of 7

Checks Dated 02/03/2021 through 03/05/2021

Check Number	Check Date	Pay to the Order of	Fund	Expensed Amount	Check Amount
5009039969	02/22/2021	Signs & Lucile Products, Inc.	212	3,325.10	
5009039995	03/01/2021	BALFOUR BEATTY CONSTRUCTION	212	6,296.00	
5009040004	03/01/2021	K & Z Cabinet Cpo. Inc.	212	161.61	
5009040008	03/01/2021	M/M Mechanical Inc.	212	6,360.00	
5009040015	03/01/2021	Reed Mechanical Systems Inc.	212	5,770.20	
5009040061	03/04/2021	Venco Electric	212	3,651.31	
Total Number of Checks			16	177,195.05	
5009039798	02/04/2021	Atkinson, Andelson, Loya, Ruud & Romo	251	2,992.50	
5009039838	02/09/2021	Tetra Tech Divisions	251	7,338.50	
Total Number of Checks			2	10,331.00	
5009039798	02/04/2021	Atkinson, Andelson, Loya, Ruud & Romo	490	213.75	
5009039835	02/09/2021	RND Contractors, INC	490	113,931.58	
5009039836	02/09/2021	Standard Drywall, Inc.	490	132,035.35	
5009039841	02/09/2021	ZIONS BANK CORPORATE TRUST DIVISION	490	6,050.00	
5009039920	02/18/2021	Benner and Carpenter Inc.	490	411.60	
5009039942	02/18/2021	Venco Electric	490	6,056.25	
5009039992	03/01/2021	ACH Mechanical Contractors	490	37,234.84	
5009039993	03/01/2021	A4E	490	7,640.77	
5009040000	03/01/2021	Floored Tile & Stone, Inc	490	1,550.00	
5009040004	03/01/2021	K & Z Cabinet Cpo. Inc.	490	18,561.88	
5009040013	03/01/2021	Pierre Landscapes, Inc	490	12,899.90	
Total Number of Checks			11	336,585.92	

Fund Recap

Fund	Description	Check Count	Expensed Amount
010	General Fund	217	1,561,803.97
130	Cafeteria Fund	29	406,783.20
212	Building Fund Measure L	16	177,195.05
251	CAPITAL FACILITIES - RESIDENTI	2	10,331.00
490	Capital Projects Fund for Blen	11	336,585.92
Total Number of Checks		267	2,492,699.14
Less Unpaid Tax Liability			381.76-
Net (Check Amount)			2,492,317.38

The preceding Checks have been issued in accordance with the District's Policy and authorization of the Board of Trustees. It is recommended that the preceding Checks be approved.

ESCAPE ONLINE

10.10



Agenda Item Details

Meeting	Mar 17, 2021 - RSD Regular Board Meeting
Category	10. Consent
Subject	10.10 Approval of Agreement for Police School Resource Officer Services by Ventura County Sheriff's Office and Rio School District for 2020/2021 at Rio Del Valle.
Access	Public
Type	Action (Consent)
Fiscal Impact	Yes
Budgeted	Yes
Budget Source	General Fund
Recommended Action	Staff recommends the approval of the Contract between the the Ventura County Sheriff's Office and the Rio School District for a Resource Officer at Rio Del Valle.
Goals	<p>Goal 3-Create welcoming and safe environments where students attend and are connected to their school</p> <p>Goal 1-Improved student achievement at every school and every grade in all content areas</p>

Public Content

Speaker:
Wael Saleh, Assistant Superintendent, Business Services

Rationale:

During the 2020-2021 school year, the district entered into an agreement for School Resource Officer services with the Ventura County Sheriff's Office. The SRO Officer will commence services starting March 22, 2021 through June 30, 2021. Services will be provided for 8 hours per Monday and 4 hours per Wednesday, for a total of \$12,696.00.

[Rio Contract 2021 \(2\).pdf \(92 KB\)](#)

Administrative Content

Executive Content

Our adopted rules of Parliamentary Procedure, Robert's Rules, provide for a consent agenda listing several items for approval of the Board by a single motion. Most of the items listed under the consent agenda have gone through Board subcommittee review and recommendation. Documentation concerning these items has been provided to all Board



VENTURA COUNTY SHERIFF'S OFFICE

Bill Ayub
Sheriff
Monica McGrath
Undersheriff

800 South Victoria Avenue, Ventura CA 93009 | 805.654.2380 | VenturaSheriff.org

February 22, 2021

Wael Saleh, Assistant Superintendent
Rio School District
2500 East Vineyard Avenue
Oxnard, CA 93036

Dear Mr. Saleh:

Re: Agreement for Police Services – Rio School District

The purpose of this letter is to outline the reimbursement to be paid by the District in accordance with the Sheriff's Department contract rates for a School Resource Officer (SRO) at Rio Del Valle Middle School. Please sign and return to me. I will return fully executed copies.

This agreement encompasses one deputy sheriff as a School Resource Officer at Rio Del Valle Middle School for an abbreviated school year of 15 weeks beginning March 22, 2021 and concluding June 30, 2021. This includes 8 Mondays at eight hours each and 7 Wednesdays at four hours each.

The anticipated billing for the contracted services period of March 22, 2021 through June 30, 2021 for Rio School District will be \$12,696.00 (8 weeks @ 8hrs/Mondays + 7 weeks @ 4hrs/Wednesdays = 92 hrs. x \$138.00/hour). This figure is an estimate only and may vary when the actual associated costs are known. Also, this figure does not include any additional costs associated with summer school, special events, modifications of schedules, or unforeseen incidents where the SRO is requested to stay beyond normal working hours. The figure also does not include costs associated with filling behind the SRO should he/she need to take a day off and coverage is requested.

The contract is contingent upon Rio School District agreeing to pay the fee listed above. The Ventura County Sheriff's Office will maintain control and responsibility for the deputy's duties and actions. By signing below, the District is agreeing to the terms and conditions outlined above.

Please sign this letter and return to me via email at randy.downard@ventura.org.

Sincerely,

Randy Downard Date
Captain
Ventura County Sheriff's Office

Wael Saleh Date
Assistant Superintendent
Rio School District

10.11



Agenda Item Details

Meeting	Mar 17, 2021 - RSD Regular Board Meeting
Category	10. Consent
Subject	10.11 Approval of California Lutheran University MOU - ADEPT Training
Access	Public
Type	Action (Consent)
Fiscal Impact	Yes
Dollar Amount	10,000.00
Budgeted	Yes
Budget Source	Title II funds Professional Development
Recommended Action	Staff recommends board approval of the California Lutheran University MOU to hold an ADEPT training on March 23, 2021.

Public Content

Speaker: Oscar Hernandez

Rationale:

California Luthern University will provide a workshop session on March 23, 2021 from 3:30 to 6:30 pm in A Developmental English Proficiency Test (ADEPT) for teachers in Rio School District. The professional learning workshop will be held virtually via Zoom. No cost allowance will be made for training facilities or equipment. During the last hour of this workshop, participants will learn how to administer the ADEPT assessment in a virtual setting. Teachers who have previously attended a CRLP ADEPT workshop may attend the last hour of the session in order to learn about the online administration of ADEPT.

Training cost will not exceed \$10,000. Cost depends on the number of registered participants.

March 2021 ADEPT Rio School District MOU.pdf (119 KB)

Administrative Content

Executive Content

Our adopted rules of Parliamentary Procedure, Robert's Rules, provide for a consent agenda listing several items for approval of the Board by a single motion. Most of the items listed under the consent agenda have gone through Board subcommittee review and recommendation. Documentation concerning these items has been provided to all Board

Memorandum of Understanding

California Reading & Literature Project at California Lutheran University And Rio School District

This agreement is entered into between the California Reading & Literature Project (CRLP-CLU) at California Lutheran University and Rio School District (RSD).

Now therefore, the parties mutually agree to accomplish specific goals as follows:

I. Project Work Plan

CRLP-CLU to provide a workshop session in *A Developmental English Proficiency Test* (ADEPT) for teachers in Rio School District. The professional learning workshop will be held virtually via Zoom. No cost allowance will be made for training facilities or equipment. During the last hour of this workshop, participants will learn how to administer the ADEPT assessment in a virtual setting. Teachers who have previously attended a CRLP ADEPT workshop may attend the last hour of the session in order to learn about the online administration of ADEPT.

CRLP-CLU will provide ADEPT manuals and handouts as needed.

II. Project Period

The session will be held from 3:30-6:30pm **after the regular school day.**

Session Date: March 23, 2021

III. Personnel and other Expenses

CRLP-CLU to provide:

- Trainer
- Clerical staff time
- ADEPT Teacher's Manuals
- CSMP demographic and evaluation forms
- Training Materials/ Handouts
- Zoom registration link
- ADEPT workshop flyer to distribute to the RSD teachers

Rio School District:

- The district will help in distributing ADEPT manuals and usage agreements.

IV. Cost of Services and Payment

The enrollment fee for the training course is **\$175 per new participant to the ADEPT training**. The enrollment fee for the training course is **\$60 per participant, who have previously attended ADEPT trainings**. There is no charge for administrators to attend. **Additional manuals for previous ADEPT attendees will be \$30 per manual.**

CRLP-CLU will directly invoice the school district after the completion of the training. The school district will remit payment to CRLP-CLU within 30 days of receipt of the invoice. **A minimum of 15 participants must be registered in order for this training to occur.**

Checks should be made payable to “California Lutheran University” and sent to:
California Lutheran University-CRLP
Attn: Courtney Ketcham, Administrative Assistant
60 W. Olsen Road # 4100
Thousand Oaks, CA 91360

V. General Terms and Conditions

A minimum of 15 participants must be registered in order for this training to occur. Additional participants may be added less than 2 weeks prior to training if there are sufficient materials available for them. Any participants who are added before/after the registration deadline or attend the day of the event will be charged the enrollment fee. Participants registering for just the final hour of the session (online administration of the assessment) may be added up to 1 day before the training.

Insurance Hold Harmless

CRLP-CLU agrees to render a certificate of liability insurance to Rio School District indicating coverage of CRLP-CLU and its agents, employees, and students for their acts, failure to act, or negligence arising out of or caused by the activity which is the subject of this Agreement.

Rio School District agrees that it will indemnify and hold harmless CRLP-CLU, its servants, agents and employees, and any students acting as such, from any and all liability, damage, expense, causes of action, suits, claims, or judgments arising from injury to person(s) or personal property or otherwise which arises out of the act, failure to act, or negligence of Rio School District, its servants, agents, or employees, in connection with or arising out of the activity which is the subject of this Agreement.

Rio School District will be additionally insured.

VI. Project Management

The parties responsible for review and approval of activities supported by this agreement are named below:

Tom Marsh
Controller
California Lutheran University
60 West Olsen Road, #1290
Thousand Oaks, CA 91360-2700
(805) 493-3181

Oscar Hernandez
Assistant Superintendent, Educational
Services
Rio School District
1800 Solar Drive
Oxnard, CA 93030
(805) 485-3111

Michael R. Hillis, Ph.D.
Dean, Graduate School of Education
California Lutheran University
60 West Olsen Road, #4100
Thousand Oaks, CA 91360
(805) 493-3422

Questions about this training may be directed to the following parties:

Nancy Myers
Director, CRLP Project
California Lutheran University
60 West Olsen Road, #4100
Thousand Oaks, CA 91360-2700
(805) 493-3599

Courtney Ketcham
Administrative Assistant
California Lutheran University
60 West Olsen Road, #4100
Thousand Oaks, CA 91360-2700
(805) 493-3705

In Witness whereof, the parties hereto have caused this Agreement to be executed by their duly authorized representatives.

By: _____
Tom Marsh Date

By: _____
Oscar Hernandez Date

By: _____
Michael R. Hillis Date

10.12



Agenda Item Details

Meeting	Mar 17, 2021 - RSD Regular Board Meeting
Category	10. Consent
Subject	10.12 Approval of California Mini-Corps MOU
Access	Public
Type	Action (Consent)
Fiscal Impact	No
Budgeted	No
Budget Source	Not applicable
Recommended Action	Staff recommends board approval of the California Mini-Corps MOU.

Public Content

Speaker: Oscar Hernandez

Rationale:

The Mini-Corps (MC) Program partners with schools in addressing the academic needs of migratory students throughout California by providing tutorial instruction, including via schools' distance learning platforms, to migratory students.

Our MC tutors are full-time college students pursuing a career in education. Butte County Office of Education is the employing agency and all tutors have TB and fingerprint clearance and have successfully passed a basic skill assessment set forth by BCOE hiring guidelines. The role of tutors is to provide instructional tutorial services in content areas, primarily in the areas of the language arts and mathematics and may also include progress monitoring.

The program relies on college students to work as teacher assistants ("Mini-Corps Tutors") in migrant impacted schools, serving as role models and mentors, and providing the following direct services to migratory students: various forms of tutoring, home visits; post-secondary awareness; career awareness; ELD or bilingual instruction and other content areas including math and ELA.

2020-21 BCOE-CMC & Rio School District MOU - BCOE Signed.pdf (518 KB)

Administrative Content

Executive Content



Mary Sakuma
Superintendent
msakuma@bcoe.org

Tad Alexander
Associate Superintendent
tal Alexander@bcoe.org
(530) 532-5720

California Mini-Corps
1760 Creekside Oaks
Drive, Suite 190
Sacramento, CA 95833
(916) 929-2713
Fax: (916) 929-2739



Yvette Medina
Sr. Director
ymedina@bcoe.org

Board of Education

Mike Walsh
Karin Matray
Brenda J. McLaughlin
Roger Steel
Amy Christianson
Alan White
Julian Diaz

Statewide & Local Support Services

1859 Bird Street
Oroville, CA 95965
(530) 532-5761
Fax (530) 532-5762
www.bcoe.org

An Equal Opportunity
Employer

January 1, 2021

Oscar Hernandez, Assistant Superintendent
Educational Services
Rio School District
2500 E Vineyard Ave, Suite #100
Oxnard, CA 93036

Dear Mr. Hernandez,

Thank you in advance for supporting the California Mini-Corps (CMC) program and the migratory students in your school during these unprecedented times. The Mini-Corps (MC) program is pleased to once again partner with schools in addressing the academic needs of migratory students throughout California by providing tutorial instruction, including via schools' distance learning platforms, to migratory students.

Our MC tutors are full-time college students pursuing a career in education. Butte County Office of Education (BCOE) is the employing agency and all tutors have TB and Fingerprint Clearance and have successfully passed a basic skills assessment set forth by BCOE hiring guidelines. Mini-Corps tutors are placed under the direct supervision of certificated teachers at all times and they do not transport students or parents. The role of tutors is to provide instructional tutorial services in content areas, primarily in the areas of language arts and mathematics and may also include progress monitoring and puppetry presentations to migratory students. The MC tutors may assist the teacher by providing review and reinforcement of the concepts taught by working with migratory students on an individual basis, small or large group settings. The MC instructional support may take place during the regular school program, summer school, after school or Saturday school, provided the tutor is under the supervision of a credentialed teacher. The MC tutor is a bilingual role model and can also provide instruction in Spanish or in the primary home language of the migratory student. Through these assignments and guidance from the supervising teacher, the tutors will gain valuable field experience in many areas including lesson planning, classroom curricula, classroom management and group instruction, using technology platforms for distance learning support (i.e. Zoom, Google Classroom, etc.).

The CMC program is working with CDE representatives to identify valid and reliable assessment tools that examine the academic growth of migratory students. The assessments' focus will be English Language Arts. Once established and upon implementation of the assessment, the CMC program will capture the data and analyze the results which may be shared with the migrant region and CDE as per our CDE contract.

Please keep in mind that we are a categorical program and can only provide supplemental instructional services to identified migratory students. If you are interested in having Mini-Corps tutors in your district, enclosed are two copies of the Memorandum of Understanding (MOU) that Mini-Corps utilizes when collaborating with educational organizations throughout the state. Please sign both MOUs and return one set to our office at your earliest convenience. The College Coordinator is available to work closely with you and your staff when making assignments and placements of Mini-Corps tutors during this fiscal year, up to June 30th, 2021.

If you have any questions or concerns, please contact the Mini-Corps college coordinator or call me directly.

Sincerely,

Yvette Medina, Sr. Director
CALIFORNIA MINI-CORPS

YM/la
Cc: Sandra Montecalvo, College Coordinator

**MEMORANDUM OF UNDERSTANDING
FOR BUTTE COUNTY OFFICE OF EDUCATION/CALIFORNIA MINI-CORPS
AND RIO SCHOOL DISTRICT
(2020-2021 FISCAL YEAR)**

This Agreement for Services ("Agreement") is made and entered into as of the 1st day of January, 2021 , by and between the BUTTE COUNTY OFFICE OF EDUCATION/CALIFORNIA MINI-CORPS ("BCOE"), a component of the California Master Plan for Migrant Education, P.L. 98-211, and RIO SCHOOL DISTRICT ("DISTRICT"), (together, "Parties").

WHEREAS, the primary objective of the California Mini-Corps Program ("Program") is to provide direct instructional services to migratory students in the district.

WHEREAS, the Program relies on college students to work as teacher assistants ("Mini-Corps Tutors") in migrant impacted schools, serving as role models and mentors, and providing the following direct services to migratory students: various forms of tutoring, including individual tutoring, tutorial instruction in academic subjects, extended day tutoring, home visits; post-secondary awareness; career awareness; ELD or bilingual instruction and other content areas including math and ELA.

WHEREAS, there is a need for the Program in the District, which is located within the Migrant Operating Agency, Region 17 (the "Region");

WHEREAS, the Program is administered by BCOE; and

WHEREAS, District seeks the provision of Program services from BCOE for migratory students in the Region.

NOW, THEREFORE, in order to implement and conduct the program during the 2020-2021 fiscal year, the Parties agree as follows:

1. **Services.** This Agreement is made and entered into for the provision of Program services for migratory students grades K-12 located within the Region, as further described in **Exhibits "A" and "B,"** attached hereto and incorporated herein by this reference ("Services").
2. **Term.** The term of this agreement is contingent upon BCOE's receipt of funding. Services shall commence under this Agreement on January 1, 2021 and will continue until June 30, 2021, unless this Agreement is terminated and/or otherwise cancelled prior to that time.
3. **Payment.** In the event additional Mini-Corps Tutors and/or hours are requested beyond what is available to the region per BCOE's contract with the California Department of Education (CDE), District shall pay BCOE for the actual cost of the Services as described in **Exhibits "A" and "B"**.
4. **Termination.** It is expressly understood and mutually agreed that the success of the program is the condition for the continuation of this agreement. Either party may, at any time, with or without reason, terminate this Agreement. Written notice by the terminating party shall be sufficient to stop further provision of Services. Notice shall be deemed given when received by the non-terminating party or no later than three (3) days after the day of mailing, whichever is sooner.
5. **Indemnification.** To the furthest extent permitted by California law, each party shall defend, indemnify, and hold harmless the other party, its Governing Board, agents, representatives, officers, consultants, employees, trustees, and volunteers (the "indemnified parties") from any and all claims arising out of, pertaining to, or relating to the negligence, recklessness, or

willful misconduct of the indemnifying party. The indemnifying party shall have the right to accept or reject any legal representation that the other party proposes to defend the indemnified parties.

6. **Insurance.** Each party shall procure and maintain at all times insurance with minimum limits as customary for that party's course of business. Certificates and insurance policies for each party shall name the other party and Tutors provided under this Agreement as additional insureds, and provide for not less than thirty (30) days' notice of cancellation or material charge. Parties shall provide each other with a certificate of insurance stating these conditions prior to the commencement of services under this Agreement. Such insurance shall be maintained with insurance carriers licensed to transact business in the State of California.
7. **Anti-Discrimination.** It is the policy of the BCOE that in connection with all work performed under contracts there be no discrimination against any person engaged in the work because of race, color, ancestry, national origin, religious creed, physical disability, medical condition, marital status, sexual orientation, gender, or age and therefore District agrees to comply with applicable Federal and California laws including, but not limited to the California Fair Employment and Housing Act beginning with Government Code Section 12900 and Labor Code Section 1735 and District policy.
8. **No Rights in Third Parties.** This Agreement does not create any rights in, or inure to the benefit of, any third party except as expressly provided herein.
9. **Limitation of BCOE Liability.** Other than as provided in this Agreement, BCOE's financial obligations under this Agreement shall be limited to the provision of funding and expenses provided in this Agreement. Notwithstanding any other provision of this Agreement, in no event, shall BCOE be liable, regardless of whether any claim is based on contract or tort, for any special, consequential, indirect or incidental damages, including, but not limited to, lost profits or revenue, arising out of or in connection with this Agreement or the Services performed in connection with this Agreement.
10. **Notice.** Any notice required or permitted to be given under this Agreement shall be deemed to have been given, served, and received if given in writing and either personally delivered or deposited in the United States mail, registered or certified mail, postage prepaid, return receipt required, or sent by overnight delivery service, or facsimile transmission, addressed as follows:

BCOE:

Butte County Office of Education
Mini-Corps Sr. Director
1760 Creekside Oaks Drive, Suite 190
Sacramento, CA 95833
FAX: (916) 929-2739
ATTN: Yvette Medina

DISTRICT:

Rio School District
Assistant Superintendent
2500 E. Vineyard Ave.
Oxnard, CA 93036
FAX:
ATTN: Oscar Hernandez

Any notice personally given or sent by facsimile transmission shall be effective upon receipt. Any notice sent by overnight delivery service shall be effective the business day next following delivery thereof to the overnight delivery service. Any notice given by mail shall be effective three (3) days after deposit in the United States mail.

11. **Integration/Entire Agreement of Parties.** This Agreement constitutes the entire agreement between the Parties and supersedes all prior discussions, negotiations, and agreements, whether oral or written. This Agreement may be amended or modified only by a written instrument executed by both Parties.

12. **Assignment.** The obligations and/or interests of either party under this Agreement shall not be assigned or transferred in anyway without written consent from the other party.
13. **Independent Contractor.** The BCOE, in the performance of its obligations under this Agreement, shall be and act as an independent contractor and at no time be considered the agent of District.
14. **California Law.** This Agreement shall be governed by and the rights, duties and obligations of the Parties shall be determined and enforced in accordance with the laws of the State of California. The Parties further agree that any action or proceeding brought to enforce the terms and conditions of this Agreement shall be maintained in Butte County.
15. **Waiver.** The waiver by either party of any breach of any term, covenant, or condition herein contained shall not be deemed to be a waiver of such term, covenant, condition, or any subsequent breach of the same or any other term, covenant, or condition herein contained.
16. **Severability.** If any term, condition or provision of this Agreement is held by a court of competent jurisdiction to be invalid, void or unenforceable, the remaining provisions will nevertheless continue in full force and effect, and shall not be affected, impaired or invalidated in any way.
17. **Provisions Required By Law Deemed Inserted.** Each and every provision of law and clause required by law to be inserted in this Agreement shall be deemed to be inserted herein and this Agreement shall be read and enforced as though it were included therein.
18. **Authority to Bind Parties.** Neither party in the performance of any and all duties under this Agreement, except as otherwise provided in this Agreement, has any authority to bind the other to any agreements or undertakings.
19. **Attorney Fees/Costs.** Should litigation be necessary to enforce any terms or provisions of this Agreement, then each party shall bear its own litigation and collection expenses, witness fees, court costs and attorney's fees.
20. **Captions and Interpretations.** Paragraph headings in this Agreement are used solely for convenience, and shall be wholly disregarded in the construction of this Agreement. No provision of this Agreement shall be interpreted for or against a party because that party or its legal representative drafted such provision, and this Agreement shall be construed as if jointly prepared by the Parties.
21. **Calculation of Time.** For the purposes of this Agreement, "days" refers to calendar days unless otherwise specified.
22. **Signature Authority.** Each party has the full power and authority to enter into and perform this Agreement, and the person signing this Agreement on behalf of each Party has been properly authorized and empowered to enter into this Agreement.
23. **Counterparts.** This Agreement and all amendments and supplements to it may be executed in counterparts, and all counterparts together shall be construed as one document.
24. **Incorporation of Recitals and Exhibits.** The Recitals and each exhibit attached hereto are hereby incorporated herein by reference.

IN WITNESS WHEREOF, the Parties hereto have executed this Agreement on the date indicated below.

Dated: _____, 20__

Dated: _____, 20__

BUTTE COUNTY OFFICE OF EDUCATION

RIO SCHOOL DISTRICT

By:

Mary Sakuma

By:

Print Name: Mary Sakuma

Print Name: _____

Print Title: Superintendent

Print Title: _____

TA 

EXHIBIT "A"
BUTTE COUNTY OFFICE OF EDUCATION/CALIFORNIA MINI-CORPS
DUTIES AND OBLIGATIONS

UNDER THIS AGREEMENT BCOE AGREES TO:

1. Provide 1 Mini-Corps Tutor, subject to funding availability, to work with migratory students at select schools within the district, during the 2020-2021 fiscal year.
2. Select Tutors may use pre/post assessments with select migrant students served. In some cases, 3rd – 12th grade students may be surveyed for the purpose of assessing our program services.
3. If puppetry tutors are requested for summer school, puppetry presentations may be conducted during summer school programs, depending on availability of trained Mini-Corps Tutors.
4. Provide the District with a Program College Coordinator that will directly supervise Mini-Corps Tutors assigned to the region and will monitor Mini-Corps Tutors' work hours.
5. Ensure the Program Coordinator meets with District Administrator or designee to review the placement list and provide program updates as needed.
6. Ensure Mini-Corps Tutors are assigned to work under the direct supervision of a credentialed teacher and preferably in a classroom setting.
7. Provide professional development for Mini-Corps Tutors that will include but it is not limited to:
 - a. A minimum of 54 hours of training.
 - b. A Summer Institute Training in Sacramento, or alternate location, in June.
8. Develop all necessary recruitment announcements, posters, brochures, applications, etc.
9. Provide presentation(s) by Program Coordinator and Mini-Corps Tutor(s) at the local sites of the district on the Mini-Corps Program as needed.
10. Recruit former migratory high school students.
11. Recruit, select, and hire the Mini-Corps Tutors.
12. Ensure that all Mini-Corps staff obtains DOJ/FBI clearances before they are assigned to work at a school. If necessary, provide verification letters of fingerprint clearances to the district.
13. Ensure all Mini-Corps staff is covered under workmen's compensation insurance.
14. Ensure that all Mini-Corps Tutors have TB and Fingerprint clearance and have successfully passed a basic skills assessment set forth by BCOE hiring guidelines.
15. Work with Priority for Service (PFS) and other migratory students and be involved in traditional and non-traditional school activities.
16. Work cooperatively with District designee in making Mini-Corps Tutor placements during the fiscal year.
17. Communicate with designated staff regarding any problems or issues with Mini-Corps Tutor placements.
18. Take immediate action to remedy any problems regarding Mini-Corps program at all placement sites.
19. Supervise, observe, and monitor Mini-Corps Tutors that are providing instructional services to migratory students.
20. Complete an evaluation of the Mini-Corps Tutor with input from the master teacher for school year and summer program.
21. The Program Coordinator and Mini-Corps Tutors will attend local in-service trainings conducted by the region if needed.

22. Provide information to the district regarding Mini-Corps activities.
23. Meet with District staff as needed.
24. Schedule and provide presentations to Migrant Parent Advisory Council(s) if needed.
25. Schedule state staff business meetings and training sessions for the Program Coordinators so they can use the Trainer of Trainers model with the tutors that provide tutorial support to the migratory students served.
26. Additional Mini-Corps Tutor Hours:
 - a. If District requests additional Mini-Corps Tutor hours, BCOE shall invoice District for any additional Tutor slots/hours beyond the allocation in item number 1 above as provided in this section.
 - b. Rate: District will be invoiced for the actual cost of additional Mini-Corps Tutor hours at the rate of \$13.50/hr or actual cost (in the event BCOE increases the tutor hourly rates) including statutory benefits and the CDE approved indirect rate for BCOE.
27. Mini-Corps will provide District with progress report from assessment(s) as needed.

EXHIBIT "B"
DISTRICT DUTIES AND OBLIGATIONS

UNDER THIS AGREEMENT DISTRICT AGREES TO:

1. Identify the schools to be served by Mini-Corps Tutors where there is an academic need to provide tutorial and progress monitoring services to select migratory students.
2. District will identify schools to be served by Mini-Corps Tutors if puppetry tutors are requested for summer school. This request will be dependent on availability of trained Mini-Corps Tutors.
3. Distribute recruitment forms to their area staff and high school seniors.
4. Inform the Program Coordinator of regional parent meetings where the Program Coordinator can distribute program information.
5. Provide a list of graduating migratory students to Program Coordinator for recruitment purposes.
6. Assist in recruiting prospective Mini-Corps Tutors and participate in the interview panel as needed.
7. Inform schools, as needed, that Mini-Corps Tutors completed a basic skills assessment adopted by BCOE that meets the paraprofessional ESSA (Every Student Succeeds Act) requirement guidelines and Department of Justice (DOJ)/Federal Bureau of Investigation (/FBI) clearances.
8. Submit a request for Mini-Corps Tutors for college/university based and/or special projects with dates of program, work hours, site contact person, etc., if applicable.
9. Collaborate and coordinate with Program Coordinator to ensure that Mini-Corps Tutors assist and participate in educational activities such as Student/Parent Conferences, Saturday Schools, or Leadership Conferences.
10. Ensure Mini-Corps Tutors are assigned to work under the direct supervision of a credentialed teacher and preferably in a classroom setting.
11. Confer with the Program Coordinator on the placement, program schedule changes and reassignments of Mini-Corps Tutors during the fiscal year.
12. Notify the Program Coordinator of local trainings in which Mini-Corps staff can attend.
13. Notify the Program Coordinator of meetings where the Program Coordinator's presence is required.
14. Contact the Mini-Corps Program when there is a problem impacting the programs.
15. Provide Mini-Corps Tutors with instructional material to work with migrant children during special projects or summer programs.
16. If District requests additional Mini-Corps Tutor slots/hours, as provided in **Exhibit "A"**, District will be invoiced for the actual costs beyond the allocation stipulated in **Exhibit "A"**.

10.13



Agenda Item Details

Meeting	Mar 17, 2021 - RSD Regular Board Meeting
Category	10. Consent
Subject	10.13 Approval of Service Learning Agreement with California State University Channel Islands
Access	Public
Type	Action (Consent)
Fiscal Impact	No
Budgeted	No
Budget Source	Not applicable
Recommended Action	It is recommended that the Governing Board approves this Volunteer Service Agreement. The purpose of this activity is to enrich students' lives" by extending education into the worldwide classroom through activities with CSUCI university students, and providing an opportunity for learning through reading, discussing literature, experiencing, and interacting.

Public Content

Speaker: Oscar Hernandez

Rationale:

Río Real Elementary School and the Río School District have both had a long standing relationship with California State University Channel Islands and the (CSU) system. These partnerships significantly contribute to student and faculty learning. Each year Río benefit from the collaboration with university professors, student teachers and other CSU faculty, staff, and students. Together through training, research, and service projects, they contribute to shaping solutions that address the needs of Río's schools and students. Community partners are integral to the success of our schools and we benefit from volunteers who look like and sound like our students. CSUCI is a Hispanic serving institution which reflects the demographic makeup of our district. Our CSUCI partners serve as co-educators who facilitate onsite learning and reflection for Río and CSU Channel Islands (CI) students.

The Center for Community Engagement (CCE) at CSUCI serves to create, maintain, and sustain partnerships with local and regional communities. It is our goal to initiate a partnership with the CSUCI which will allow Río Real to work with CSUCI professors and students, on various projects one of which is a Book Club for Río Real middle school students. We are looking for a long term, formal agreement which requires a Service Learning Agreement (SLA) to be on file. The SLA guides risk management and addresses potential liability issues. With the SLA in place, participating CSUCI students are covered by the CSU's Student Academic Field Experience for Credit Liability Insurance Program (SAFECLIP). SAFECLIP provides indemnity to the partner (Río School District) and prevailing third party, as well as legal defense costs for CSUCI students, faculty, University, and partner, should a claim or lawsuit involving injury to others or damage to property arise.

The SLA supports efforts to prepare and monitor university students, provide quality service, and apprise community partners of expectations for our students' quality of experience. Moreover, the SLA ensures that the community partner is listed in the SL database (CSUCI SERVES), providing visibility and opportunities to more students to volunteer in schools.

With approval, Río will be eligible to host CSUCI service-learning students for a period of up to three years, with renewals offered and managed by Contracts staff.

Questions regarding the service-learning agreement can be directed at Risk Management (805-437-8846).

DRAFT_Service Learning Agreement_2019 (006).pdf (249 KB)

California State University Channel Islands Service Learning Agreement

This Agreement entered into between the Trustees of the California State UNIVERSITY on behalf of California State UNIVERSITY Channel Islands, hereafter referred to as "UNIVERSITY," and _____ thereafter referred to as Community-Based Organization or "CBO".

I. STATEMENT OF PURPOSE

CBO and UNIVERSITY recognize the opportunity for meaningful service-learning experiences for the UNIVERSITY, CBO and service-learning students (STUDENT). The UNIVERSITY supports the goals and objectives of the CBO program in which the STUDENTS will participate.

II. RESPONSIBILITIES

A. CBO's responsibilities:

1. California law may require the CBO to obtain STUDENT's fingerprints and submit them to the Department of Justice, and/or the Federal Bureau of Investigation, for a criminal background check. It is the CBO's responsibility to: 1) determine whether such fingerprinting is required; 2) obtain the STUDENT's fingerprints; and 3) obtain criminal background clearance from the appropriate agency, and 4) incur the costs of fingerprinting.
2. Inform student of the need for a tuberculosis test; testing shall be at the expense of the CBO; maintain the confidentiality of any results as required by federal and state law.
3. Identify the student's supervisor. The supervisor agrees to meet with the student regularly to facilitate the student's learning experience, provide support, review progress on assigned tasks, verify service hours and give feedback.
4. Provide an orientation that includes a site tour; an introduction to staff; a description of the characteristics of and risks associated with the CBO's operations, services and/or clients; a discussion concerning safety policies and emergency procedures; and information detailing where students check-in and how they log their time.
5. Provide student with a written description of the student's tasks and responsibilities.
6. Provide appropriate training, equipment, materials and work area for students prior to students performing assigned tasks or working with the CBO's clients.
7. Evaluate the student if requested by the UNIVERSITY and contact the UNIVERSITY if the student fails to perform assigned tasks or engages in misconduct.
8. Notify the UNIVERSITY as soon as is reasonably possible of any injury or illness to a student participating in a learning activity at the CBO.
9. Refrain from providing service learning opportunities that involve:
 - driving as part of service responsibilities
 - participating in activities that pose a significant safety risk to participants
 - any paid service activities

California State University Channel Islands Service Learning Agreement

B. UNIVERSITY's responsibilities

1. Advise that STUDENT agrees to participate in all training required by the CBO.
2. Advise that STUDENT agrees to Exhibit professional, ethical and appropriate behavior when at the CBO.
3. Advise that STUDENT agrees to complete all assigned tasks and responsibilities in a timely and efficient manner.
4. Advise that STUDENT agrees to abide by the CBO's rules and standards of conduct.
5. Advise that STUDENT agrees to maintain the confidentiality of the CBO's proprietary information, records and information concerning its clients.
6. The UNIVERSITY will advise STUDENTS that neither the UNIVERSITY nor the CBO assumes any financial responsibility in the event he/she is injured or becomes ill as a result of his/her participation a learning activity at the CBO.
7. Provide the STUDENT with general and professional liability insurance in the amount of \$1,000,000 per occurrence, \$3,000,000 general aggregate. This insurance is activated upon full execution of this Agreement.

III. GENERAL PROVISIONS

- A. This Agreement will become effective as of the date last written below and continue for a period of 3 years unless terminated by either party after giving the other party 30 days written notice of the intent to terminate. If the CBO terminates this Agreement, it will permit any student working at the CBO at the time of termination to complete his/her work. At the 3-year termination date the agreement can be renewed once it has been reviewed, updated as applicable and executed by the appropriate parties.
- B. The CBO and the UNIVERSITY agree to indemnify, defend and hold harmless each other from any and all liability for any personal injury, damages, wrongful death or other losses and costs, including but not limited to reasonable attorney fees and defense costs, arising out of the negligence or willful misconduct of their respective officers, employees, agents or volunteers in the performance of this Agreement. This paragraph will survive expiration or termination of this Agreement.
- C. Each party agrees to maintain general liability coverage of at least \$1,000,000 per occurrence, \$2,000,000 aggregate and to provide evidence of coverage upon request. Insurance must be placed with insurers with a current A.M. Best rating of at least A: VII.
- D. The CBO and the UNIVERSITY will meet upon request or as necessary to resolve any potential conflicts and to facilitate a mutually beneficial experience for all involved.

California State University Channel Islands Service Learning Agreement

- E. The CBO may dismiss a student if the student violates its standards, mission or goals. The CBO will document its rationale for terminating a student and provide the UNIVERSITY with a copy of the rationale upon request.
- F. Students participating in a learning activity at the CBO are not officers, employees, agents or volunteers of the UNIVERSITY or the CBO.
- G. Nothing contained in this Agreement confers on either party the right to use the other party's name without prior written permission, or constitutes an endorsement of any commercial product or service by the UNIVERSITY.
- H. This Agreement may not be altered unless both parties agree in writing. The parties agree to follow all applicable federal, state and local laws and regulations, including but not limited to laws prohibiting discrimination and harassment.
- I. Any notices required by this Agreement will be deemed to have been duly given if communicated to the following individuals:

UNIVERSITY:

Pilar Pacheco
Director, Service Learning
(805) 437-8851
pilar.pacheco@csuci.edu

CBO:

Name
Title
Phone
Email

III. CSU POLICIES, RULES AND REGULATIONS – TITLE IX

As established under California State University Executive Orders 1096 and 1097, it is CSU policy to provide equal opportunity for all persons regardless of race, religious creed, color, national origin, ancestry, physical disability, mental disability, medical condition, sex, genetic information, marital status, gender, gender identity, gender expression, age, sexual orientation, and military and veteran status in its programs and activities. UNIVERSITY provides equal accommodations, advantages, facilities, privileges and services for all members of the campus community, as well as third parties, in its programs and activities.

CBO agrees to abide by all CSU policies to the extent such policies apply to UNIVERSITY students, staff, faculty and guests, including CSU policies prohibiting discrimination, harassment, and retaliation of all students, employees and third parties in CSU educational programs and activities. CSU Executive Orders 1096 and 1097 are accessible here:

CSU Executive Order 1096 “Systemwide *Policy* Prohibiting Discrimination, Harassment, Retaliation, Sexual Misconduct, Dating and Domestic Violence, and Stalking against Employees and Third Parties and Systemwide *Procedure* for Addressing Such Complaints by Employees and Third Parties”

<http://www.calstate.edu/eo/EO-1096-rev-6-23-15.html>

**California State University Channel Islands
Service Learning Agreement**

CSU Executive Order 1097 "Systemwide Policy Prohibiting Discrimination, Harassment and Retaliation, Sexual Misconduct, Dating and Domestic Violence, and Stalking against Students and Systemwide Procedure for Addressing Such Complaints by Students"

<http://www.calstate.edu/eo/EO-1097-rev-6-23-15.html>

UNIVERSITY shall respond promptly and effectively to all reports of discrimination, harassment, and retaliation, and will take appropriate action to prevent, correct, cease, and when necessary, discipline behavior that violates this policy. Reports of possible discrimination, harassment or retaliation by CBO will result in the immediate termination of this agreement and immediate departure of the STUDENT from the CBO premises, regardless of the status of the UNIVERSITY's investigation.

IN WITNESS WHEREOF, this Agreement has been fully executed by the parties as of the date last written below.

For CSU Channel Islands:

Name

Signature

Procurement and Contracts
Title

Date

For

Name of CBO

Signature

Title

Date

10.14



Agenda Item Details

Meeting	Mar 17, 2021 - RSD Regular Board Meeting
Category	10. Consent
Subject	10.14 Approval of California Lutheran University MOU for Professional Development Services
Access	Public
Type	Action (Consent)
Fiscal Impact	Yes
Dollar Amount	7,000.00
Budgeted	Yes
Budget Source	Title II Funds
Recommended Action	Staff recommends board approval of the MOU with California Lutheran University.

Public Content

Speaker: Oscar Hernandez

Rationale:

California Lutheran University will provide a customized Results word recognition and fluency institute for Rio School District kindergarten push-in teachers. The ten one-hour professional learning session will be held virtually and facilitated by an RSD teacher who is a certified California Reading & Literature Project (CRLP) trainer. The teachers can later participate in Results review sessions provide by the lead CRLP-RSD Results coach. Total cost of services will be a \$7,000 flat rate for the institute, coaching sessions and office hours.

[CLU Results PD MOU.pdf \(184 KB\)](#)

Administrative Content

Executive Content

Our adopted rules of Parliamentary Procedure, Robert's Rules, provide for a consent agenda listing several items for approval of the Board by a single motion. Most of the items listed under the consent agenda have gone through Board subcommittee review and recommendation. Documentation concerning these items has been provided to all Board

Memorandum of Understanding

California Reading & Literature Project at California Lutheran University and Rio School District

This agreement is entered into between the California Reading & Literature Project at California Lutheran University and Rio School District.

Now therefore, the parties mutually agree to accomplish specific goals as follows:

I. Project Work Plan

CRLP-CLU to provide a customized *Results Word Recognition and Fluency* institute for Rio School District Kindergarten Push-In Teachers. The ten one-hour professional learning sessions will be held virtually and facilitated by an RSD teacher who is a certified CRLP trainer. The teachers can later participate in Results review sessions provided by the lead CRLP-RSD Results Coach. No cost allowance will be made for training facilities or equipment.

II. Project Period

- Ten one-hour Results Word Recognition and Fluency sessions presented by a certified CRLP Results trainer (all sessions will be held time TBD)
 - Dates TBD
- Ongoing CRLP Results Foundational Skills Office Hours (voluntary attendance)
 - Monthly sessions

All sessions 2:00-3:00pm
February 16, 2021
February 17, 2021
February 23, 2021
February 25, 2021
March 2, 2021
March 4, 2021
March 9, 2021
March 11, 2021
March 16, 2021
March 18, 2021

III. Personnel and other Expenses

CRLP-CLU to provide:

- Trainer
- Clerical staff time

Rio School District to provide (in event of in-person trainings):

- Binders and printing of handouts (CRLP trainer/RSD staff will prepare the materials at the district office)
- Instructional routines materials (CRLP trainer/RSD staff will prepare the materials at the district office)

IV. Cost of Services and Payment

Cost of services to be \$7,000 flat rate for the institute, coaching sessions, and office hours. CRLP-CLU will directly invoice Rio School District after the completion of the second institute session.

Please make checks payable to:

California Lutheran University – CRLP

Attn: Courtney Ketcham, Administrative Assistant

60 W. Olsen Road # 4100, Thousand Oaks, CA 91360

V. General Terms and Conditions

participants may be added less than 2 weeks prior to training if there are sufficient materials available for them.

Insurance Hold Harmless

CRLP-CLU agrees to render a certificate of liability insurance to Rio School District indicating coverage of CRLP-CLU and its agents, employees, and students for their acts, failure to act, or negligence arising out of or caused by the activity which is the subject of this Agreement.

Rio School District agrees that it will indemnify and hold harmless CRLP-CLU, its servants, agents and employees, and any students acting as such, from any and all liability, damage, expense, causes of action, suits, claims, or judgments arising from injury to person(s) or personal property or otherwise which arises out of the act, failure to act, or negligence of Rio School District, its servants, agents, or employees, in connection with or arising out of the activity which is the subject of this Agreement.

Rio School District will be additionally insured.

VI. Project Management

The parties responsible for review and approval of activities supported by this agreement are named below:

Tom Marsh
Controller
California Lutheran University
60 W. Olsen Road, #1290
Thousand Oaks, CA 91360-2700
(805) 493-3181

Oscar Hernandez
Assistant Superintendent, Educational Services
Rio School District
2500 E. Vineyard Ave, Suite #100
Oxnard, CA 93036

Michael Hillis, PhD
Dean, Graduate School of Education
California Lutheran University
60 W. Olsen Road, #1400
Thousand Oaks, CA 91360
(805) 493-3422

Questions about this training may be directed to the following parties:

Nancy Myers

Director

California Reading and Literature Project

60 W. Olsen Rd., #4100

Thousand Oaks, CA 91360-2700

(805) 493-3599

Courtney Ketcham

Administrative Assistant

California Reading and Literature Project

60 W. Olsen Rd., #4100

Thousand Oaks, CA 91360-2700

(805) 493-3705

In Witness whereof, the parties hereto have caused this Agreement to be executed by their duly authorized representatives.

By: Tom Marsh 2-4-21
Tom Marsh Date

By: Oscar Hernandez 2/1/2021
Oscar Hernandez Date

By: Michael Hillis 2/3/21
Michael Hillis Date

10.15



Agenda Item Details

Meeting	Mar 17, 2021 - RSD Regular Board Meeting
Category	10. Consent
Subject	10.15 Approval of Change Order #1 from Kiwitt General Contractor for the added scope of work at Rio Real for the Installation of Additional Flooring and Vision Light Windows and Painting
Access	Public
Type	Action (Consent)
Fiscal Impact	Yes
Dollar Amount	9,750.00
Budgeted	Yes
Budget Source	Measure L Funds
Recommended Action	It is recommended that the Board Approve Change Order #1 from Kiwitt General Contractor for added scope of work at Rio Real for additional Flooring and Vision Light Windows and additional Painting

Public Content

Speaker:
Wael Saleh, Assistant Superintendent, Business Services

Rationale:
Additional work was added to the original job #20-27L which created a change order. The change order is for Kiwitt General Contractor to add flooring and vision light windows and additional painting to the Administration Building at Rio Real Elementary.

RSD Project #20-27L COR#1 FINAL KIWITT for March Board Approval 3 3 21 (1).pdf (125 KB)

Administrative Content

Executive Content

Our adopted rules of Parliamentary Procedure, Robert's Rules, provide for a consent agenda listing several items for approval of the Board by a single motion. Most of the items listed under the consent agenda have gone through Board

Balfour Beatty Construction

Rio School District
1800 Solar, 3rd Floor
Oxnard, CA 93030

March 3, 2021

Attn: Dr. Puglisi

Subject: Rio Real Elementary School
Rio School District
Oxnard, CA

Re: Project 20-27L COVID 19 Admin Bldg & Room #12 Renovations at Rio Real Elementary School
Kiwitt's General Building
Recommendation to Approve CO #1 to Kiwitt's General Building

Dear Dr. Puglisi,

Please accept this letter as recommendation to request approval for CO #1 to Kiwitt's General Building for Added & Deleted scope of work items at the above Project, and as amendment to their contract. Scope change to the project is as follows.

PCO No.1

GC No. KIWITT

Description: Install Additional Flooring, 2 Vision Light Windows and Additional Painting at Rio Real

Reason Cost/Credit: Upon completing a job walk with Rio Real Administrators to review the scope of work, a determination was made that additional flooring, painting and windows would need to be included that were not previously identified in the prior scope of work approved by the Rio Board

Change Order Cost: \$9,750.00

Total CO #1	\$9,750.00
Previous Approved CO's	\$ 0
Original Contract	\$63,922.00
Revised Contract	\$73,672.00

Should you have any questions, please contact me at any time.

Respectfully,



Keith Henderson
Senior Project Manager, Balfour Beatty

cc. Wael Saleh, Rio School District
Dennis Kuykendall, Balfour Beatty
Jesus Muguerza Ibarra

**Rio School District
1800 Solar, 3rd Floor
Oxnard, Ca 93030**

**CO 1
3-03-2021**

PROJECT NO: RSD 20-27L

CO NO: 1

PROJECT NAME: COVID 19 Admin Bldg & Room #12 Renovations, Rio Real

CONTRACTOR: Kiwitt's General Building

SCOPE OF WORK: SEE ATTACHED

COST:

Original Contract Amount	\$ 63,922.00
Previous Approved Change Orders	\$ 0.00
This Change Order	\$ 9,750.00
Adjusted Contract Amount	\$ 73,672.00

TIME:

Original Contract Completion Date	May 2021
Previously Approved Completion Extension Days	0
Completion Days Extension this Change Order	0
Adjusted Contract Completion Date	May 2021

IT IS AGREED BY THE CONTRACTOR THAT THE AMMENDED CONTRACT AMOUNT AND/OR TIME, IF ANY, INCLUDES FULL AND COMPLETE EQUITABLE ADJUSTMENT AND COMPENSATION FOR ALL CONTRACT WORK AND EXTRA WORK PERFORMED ON THE PROJECT INCLUDING BUT NOT LIMITED TO CHANGES, DIFFERING SITE CONDITIONS, SUSPENSIONS, DELAYS, RESCHEDULING, ACCELERATION, IMPACT AND EXTENDED OVERHEAD AS IT RELATES SPECIFICALLY TO ITEMS OF THE ATTACHED LISTING. CONTRACTOR HEREBY WAIVES ANY AND ALL RIGHT TO ADDITIONAL COMPENSATION OR TIME ARISING OUT OF THE WORK SPECIFIC TO ITEMS OF THE ATTACHED LISTING, AND HEREBY ACKNOWLEDGES AND AGREES THAT THE AMOUNT SHOWN ABOVE CONSTITUTES PAYMENT IN FULL ACCORDING TO THE CONTRACT DOCUMENTS

EXCEPT TO THE EXTENT THE CONTRACT HAS BEEN MODIFIED BY PREVIOUSLY ISSUED DISTRICT CHANGE ORDERS, AND FURTHER MODIFIED BY THIS CHANGE ORDER, THE CONTRACT REMAINS IN FULL FORCE AND EFFECT.

RIO SCHOOL DISTRICT

Contractor: Kiwitt's General Building

By _____

By _____

Date _____

Date _____

District Architect; N/A

District PM/CM; Balfour Beatty Construction

By _____

By  _____

Date _____

Date 3/3/2021 _____

PCO to Contract
Rio Bid RSD #20-27L

Rio School District
 Project No RSD 20-27L

CO #1
 3/3/2021

COVID 19 Admin Bldg & Room #12 Renovations
 Rio Real Elementary School

Original Contract \$ 63,922.00

PCO No.	GC No.	Description	Reason	Cost/Credit
1	KIWITT	Install Additional Flooring, 2 Vision Light Windows and Additional Painting at Rio Real	Upon completing a job walk with Rio Real Administrators to review the scope of work, a determination was made that additional flooring, painting and windows would need to be included that were not previously identified in the prior scope of work approved by the Rio Board	\$ 9,750.00

Total CO #1	\$ 9,750.00
Previous Approved CO's	\$ -
Original Contract	\$ 63,922.00
Revised Contract	\$ 73,672.00

CHANGE ORDER #1

KIWITT'S GENERAL BUILDING CONTRACTOR

P.O. Box 1359
SOMIS CA 93066 1359

(805) 986-4882 FAX (805) 531 0035
kiwittclan@aol.com
EPR# 1000091195 / 1000091195

TO: Rio School District
1800 Solar, 3rd Floor
Oxnard, CA 93030

Attn: Dr. Puglisi

DATE	DATE
	3/2/2021
FIRM NAME / EDUCATION	
Rio Real School 1140 Kenny street Oxnard CA 93036	
PROJECT NUMBER	PROJECT NAME
RSD Project #20-27L	

Work here includes: description, and estimate for:

Install vct flooring in all work areas including hallway and future nurses office with VCT and rubber base \$5,800.00

Install (2) additional vision lights in the 2 new doors \$750.00

Paint the hallway, and future nurses office walls including the new vision lights \$3200.00

Acceptance of this proposal includes all costs, change fees, or other expenses incurred in the collection of the above payments upon default by the contractor.

We propose to complete the above work in accordance with the above description, for the amount of **9,750.00**

Payment to be made as follows:

All items of a given kind to be delivered to the job site in accordance with the above description, and to be installed in accordance with the above description. All items of a given kind to be delivered to the job site in accordance with the above description. All items of a given kind to be delivered to the job site in accordance with the above description. All items of a given kind to be delivered to the job site in accordance with the above description.

Signature

If the above proposal is not accepted within _____ days

Acceptance of Proposal

The above prices, specifications and conditions are accepted by and on behalf of the contractor, and the work is to be completed by _____

Signature

Signature

Date of Acceptance: _____

10.16



Agenda Item Details

Meeting	Mar 17, 2021 - RSD Regular Board Meeting
Category	10. Consent
Subject	10.16 Approval of Project Award to Oilfield Electric for the District Office Generator Replacement
Access	Public
Type	Action (Consent)
Fiscal Impact	Yes
Dollar Amount	111,750.00
Budgeted	Yes
Budget Source	General Fund
Recommended Action	It is recommended that the Board of Education issue a Notice of Award to Oilfield Electric for the generator replacement at the District Office on 1800 Solar Drive, Oxnard, California.

Public Content

Speaker:
Wael Saleh, Assistant Superintendent, Business Office

Rationale:

The Rio School District received bids for RSD Project #21-01DO Generator Replacement at 1800 Solar Dr. Oxnard, Ca. The following companies submitted bids in the order listed. This Project is tentatively scheduled to be completed by May 10, 2021.

It is our recommendation that the Superintendent of Schools, per authorization by the Board of Education at its March 17, 2021 board meeting, proceed with issuing a Notice of Award to Oilfield Electric.

CONTRACTOR	Total Bid
Oilfield Electric	\$111,750.00
Venco	\$130,000.00

[1800 Solar Drive Generator Replacement Proposal.pdf \(1,267 KB\)](#)

[1800 SOLAR GENERATOR BID DOCS, VENCO.pdf \(5,149 KB\)](#)

[21-01DO Oilfield Recommendation to award 2 24 2021.pdf \(136 KB\)](#)

SECTION 00210

BID FORM
(CUPCAA PROJECTS UP TO \$200K)

TO: RIO SCHOOL DISTRICT, a political subdivision of the State of California ("District"), acting by and through its Board of Trustees ("Board"), 1800 Solar Dr. 3rd Floor, Oxnard, CA 93030.

FROM: Oilfield Electric Company dba Oilfield Electric & Motor
(Name of Bidder as listed on License)
1801 N Ventura Ave
(Address)
Ventura, CA 93001
(City, State, Zip Code)
805.648.3131 805.648.4806
(Telephone) (FAX)
Alan D Fletcher, President
(Name(s) of Bidder's Authorized Representative(s) & Title)

1. Bid.

1.1 Bid Amount. Pursuant to and in compliance with the Notice to Contractors Calling for Bids, the Instructions for Bidders and the other documents relating thereto, the undersigned bidder having reviewed the Instructions for Bidders and all other Contract Documents¹ and upon compliance with all requirements therein with reference to the submittal of this bid, hereby proposes and agrees to perform the Contract including, without limitation, all of its component parts; to perform everything required to be performed; to provide and furnish any and all of the labor, materials, tools, equipment, applicable taxes, and services necessary to perform the Contract and complete in a workmanlike manner all of the Work required for the CUPCAA Project described as: **Generator Replacement at 1800 Solar, Oxnard, Ca. RSD Project # 21-01DO** in accordance with the Contract Documents for the sum of:

"Total" Base Bid: Generator Replacement at 1800 Solar, Oxnard, Ca, RSD Project #21-01DO

One hundred + eleven thousand Dollars (\$) 111,750⁰⁰
(Amount in Words) Seven hundred + FIFTY (In Numbers)

The undersigned bidder agrees to achieve Final Completion of the Work within the Contract Time set forth in the Contract Documents.

¹ Capitalized terms used herein shall have the same meanings as those set forth in the General Conditions, Section 700, unless otherwise defined herein.

1.2 Alternate Bid Items Proposal. Bidders must provide a proposal price for each additive or deductive alternate bid item set forth herein; failure to do so will result in rejection of the bid proposal for non-responsiveness. After the public opening and reading of the bids, the District will in its sole and exclusive discretion select all, some or none of the additive or deductive alternate bid items for inclusion in the Contract awarded hereunder. The foregoing notwithstanding, if the District elects to include some, but not all of the alternate bid items in the Contract to be awarded hereunder, the selection of such alternate bid items will be by priority, as follows:

Alternates are listed from the highest to lowest priority based on their numerical orders.

Add/Alternate Bid No. 1

NONE Dollars (\$ 0.00)
(Amount in Words) (In Numbers)

1.3 Acknowledgment of Bid Addenda. In submitting this bid, the undersigned bidder acknowledges receipt of all bid addenda issued by or on behalf of the District, as set forth below. The bidder confirms that this bid incorporates and is inclusive of, all items or other matters contained in bid addenda.

Addenda No. NONE dated _____ through No. _____, dated _____, received, acknowledged and incorporated into this bid.

1.4 Alternate Bid Items. The bidder's price proposal(s) for alternate bid items is/are set forth in the form of alternate bid item proposal included herewith. The bidder acknowledges that, in accordance with the Instruction for Bidders, the Contract for the Work may be awarded in the District's sole discretion with or without some, all or none of the alternate bid items being incorporated into the scope of the Contract awarded. The bidder further acknowledges that the District's selection of alternate bid items, if any, for inclusion in the Contract awarded will be in accordance with the Instructions for Bidders.

2. Rejection of Bid; Holding Open of Bid. It is understood that the District reserves the right to reject this bid and that this bid shall remain open and not be withdrawn for the period of time specified in the Call for Bids, except as provided by law.

3. Documents Comprising Bid. The undersigned bidder has submitted as its bid the following:

1. 00210 Bid Form
2. 00215 Designation of Subcontractors
3. 00218 Contractors Registration Certification (DIR)
4. 00220 Non-Collusion Affidavit
5. 00222 Certification of Prevailing Wage
6. 00230 Contractor's Statement of Experience
7. 00240 Acknowledgment of Bidding Practices Regarding Indemnity

The bidder acknowledges that if this bid is not fully in compliance with applicable requirements set forth in the Call for Bids, the Instructions for Bidders and in each of the foregoing documents, the bid may be rejected as non-responsive.

4. **Award of Contract.** It is understood and agreed that if written notice of the acceptance of this bid and award of the Contract thereon is mailed, telegraphed or delivered by the District to the undersigned after the opening of bids and within the time this bid is required to remain open or at any time thereafter before this bid is withdrawn, the undersigned will execute and deliver to the District the Agreement in the form attached hereto in accordance with the Bid as accepted within ten (10) calendar days after notification of acceptance and award. Concurrently with delivery of the executed Agreement to the District, the bidder awarded the Contract shall deliver to the District: (a) certificates of insurance evidencing all insurance coverage required under the Contract Documents; (b) the performance bond; (c) the labor and material payment bond; (d) the Certificate of Workers' Compensation Insurance; and (e) the drug-free workplace certificate. The Work under the Contract Documents shall be commenced by the undersigned bidder, if awarded the Contract, on the date stated in the District's Notice to Proceed issued pursuant to the Contract Documents and completion of the Work shall be achieved within the Contract Time specified in the Contract Documents.
5. **Notices.** All notices or other correspondence shall be addressed to the District and the bidder at their respective addresses set forth herein. Notices shall be effective only if in writing and in conformity with the requirements for service of notices set forth in the Contract Documents.
6. **Contractor's License.** The undersigned Bidder is currently and duly licensed in accordance with the California Contractors License Law, California Business & Professions Code §§ 7000, *et seq.*, under the following:

License Number: 125250
Class C10 Expiration date 06/30/2021 Class _____ Expiration date _____
Class _____ Expiration date _____ Class _____ Expiration date _____

By executing this bid, the bidder hereby certifies that: (a) it is duly licensed, in the necessary class(es), for performing the Work of the Contract Documents; (b) that such license shall be in full force and effect throughout the duration of the performance of the Work under the Contract Documents; and (c) that all Subcontractors providing or performing any portion of the Work of the Contract Documents shall be so similarly and appropriately licensed to perform or provide such portion of the Work.

7. **Designation of Subcontractors.** In compliance with the Subletting and Subcontracting Fair Practices Act (California Public Contract Code §§ 4100, *et seq.*) and amendments thereof, each bidder shall set forth in the Subcontractors List: (a) the name and location/address of the place of business of each Subcontractor who will perform work or labor or render services to the bidder in or about the construction of the Work to be performed under the Contract Documents in an amount in excess of one-half of one percent (0.005%) of the bidder's bid; and (b) the portion of the Work which will be performed by each listed Subcontractor. The bidder shall list only one Subcontractor for each portion of

the Work as is defined by the bidder in its bid. If a bidder fails to list a Subcontractor or if the bidder specifies more than one Subcontractor for the same portion of Work to be performed under the Contract Documents valued in excess of one-half of one percent (0.005%) of the bidder's bid amount, the bidder shall be deemed to have agreed that it is "fully qualified" to perform that portion of the Work itself and that it shall perform that portion of the Work.

(In addition, refer to Specification Section 00100 Instruction to Bidders, Section 21 Subcontractors, Sub Section 21.1 Designation of Subcontractors; Subcontractors list of the contract documents.)

8. **Confirmation of Figures.** By submitting this bid, the bidder confirms that it has checked all of the above figures and understands that neither the District nor any of its agents, employees or representatives shall be responsible for any errors or omissions on the part of the undersigned bidder in preparing and submitting this bid.
9. **Acknowledgment and Confirmation.** The undersigned bidder acknowledges its receipt, review and understanding of the Drawings, the Specifications and other Contract Documents pertaining to the proposed Work. The undersigned bidder certifies that the Contract Documents are, in its opinion, adequate, feasible and complete for providing, performing and constructing the Work in a sound and suitable manner for the use specified and intended by the Contract Documents. The undersigned bidder certifies that it has, or as available, all necessary equipment, personnel, materials, facilities and technical and financial ability to complete the Work for the amount bid herein within the Contract Time and in accordance with the Contract Documents.

(Corporate Seal)

Alan D Fletcher
Signature of Bidder's Authorized Representative

Alan D Fletcher
Typed or Printed Name

President
Title

info@oilfld.com
E-mail Address of Bidder's Authorized Representative

1000001413
Department of Industrial Relations Registration Number

02/18/21
Date

END OF SECTION

SECTION 00215

**DESIGNATION OF SUBCONTRACTORS
(CUPCCAA PROJECTS UP TO \$200K)**

(Must be submitted with bid)

1. In compliance with the Subletting and Subcontracting Fair Practices Act (Government Code Section 4100, *et seq.*) and any amendments thereof, each bidder shall set forth below:
 - a. The name and the location of the place of business of each services to the prime contractor in or about the construction of the work or improvement to be performed under this contract in an amount in excess of one-half of one percent (0.005%) of the prime contractor's total bid, and
 - b. The portion of the work which will be done by each subcontractor under this act. The prime contractor shall list only one subcontractor for each portion as is defined by the prime contractor in this bid.
2. If a prime contractor fails to specify a subcontractor or if a prime contractor specifies more than one subcontractor for the same portion of work to be performed under the contract in excess of one-half of one percent (0.005%) of the prime contractor's total bid, the prime contractor shall be deemed to have agreed to be fully qualified to perform that portion of work, and that it shall be performed by the contractor.
3. No prime contractor whose bid is accepted shall:
 - a. Substitute any subcontractor without written approval by the District,
 - b. Permit any subcontract to be voluntarily assigned or transferred or allow it to be performed by anyone other than the original subcontractor listed in the original bid,
 - c. Sublet or subcontract any portion of the work in excess of one-half of one percent of the prime contractor's total bid as was originally bid and did not designate a subcontractor, except as authorized in the Subletting and Subcontracting Fair Practices Act.

Subletting or subcontracting of any portion of the work in excess of one-half of one percent (0.005%) of the prime contractor's total bid as to which subcontractor was designated in the original bid shall only be permitted to cases of public emergency or necessity, and then only after a finding reduced to writing as public record of the authority awarding this contract, setting forth the facts constituting the emergency or necessity.

NOTE: If alternate bids are called for and bidder intends to use different or additional subcontractors on the alternates, a separate list of subcontractors must be provided for each such alternate.

4. **MANDATORY REGISTRATION WITH THE DEPARTMENT OF INDUSTRIAL RELATIONS** - Senate Bill 854 requires ALL contractors and subcontractors submitting bids on public works projects to be registered with the Department of Industrial Relations ("DIR") for purposes of labor compliance. All contractors and subcontractors must submit proof of valid, accurate, and current DIR registration with their bid. Rio School District will not accept bids from any contractors or subcontractors who are not registered with the DIR at the time the bid is submitted. Any contractors or subcontractors submitting a bid without being registered with the DIR at the time of bid will have their bid rejected as being non responsive. All contractors must affirmatively acknowledge their obligation not to hire subcontractors who lack an accurate, valid DIR registration number.

SUBCONTRACTOR LIST

Subcontractor's Licensed Name and DIR Registration Number (Required)	Subcontractor Valid License Number (Required)	Complete address of Subcontractor's Office, Mill or Shop (Required)	Subcontractor's Trade or Portion of Work (Required)
RICHARD A REED BACKHOE SERVICE INC, DIR 1000032330	665998	PO Box 7164 Ventura, CA 93006	Trenching
A&A Concrete Inc DIR 1000059736	874119	9452 Telephone Rd Ventura, CA 93004	Concrete
Subcontractor's Licensed Name and Registration Number			
RICHARD A REED SERVICE INC			

Name of Bidder: Oilfield Electric Company dba Oilfield Electric & Motor

Authorized Signature: 

END OF SECTION

**SECTION 00218
CERTIFICATION OF CONTRACTOR AND
SUBCONTRACTOR DIVISION OF INDUSTRIAL RELATIONS REGISTRATION
(DIR)
(CUPCCAA PROJECTS UP TO \$200K)**

Pursuant to Public Contract Code Section 1725.5, a contractor or subcontractor must be registered with the Department of Industrial relations in order to bid on, to be listed in a bid proposal or to engage in the performance of any defined public work contract.

I, Alan D Fletcher, President certify that
(Name) (Title)

Oilfield Electric Company dba Oilfield Electric & Motor is currently registered as a contractor with the Department of Industrial
(Contractor Name)

Relations (DIR):

Contractor's DIR Registration Number 1000001413

Expiration date June 30, 2021

Contract further acknowledges:

1. Contractor shall maintain DIR registered status for the duration of the project without a gap in registration.
2. Contractor shall note in its invitation to bid the DIR's registration requirement for all subcontractors and their subcontractors.
3. Contractor shall ensure that all subcontractors are registered at time of bid opening and maintain registered status for the duration of the project.
4. Contractor is to furnish DIR Registration Number for all subcontractors on the project within 24 hours of the bid opening.
5. Contractor shall substitute any subcontractor with a DIR registered contractor if listed subcontractor is unable to perform the work.

Failure to comply with any of the above may result in a determination of non-responsiveness.

I declare under penalty of perjury under California law that the foregoing is true and correct.

Alan D Fletcher
Signature

02/18/2021
Date

(CUPCCAA PROJECT) SECTION 00218
CERTIFICATION OF CONTRACTOR AND SUBCONTRACTOR DIVISION OF INDUSTRIAL RELATIONS
REGISTRATION
Generator Replacement at 1800 Solar
RSD Project # 21-01DO

SECTION 00220

NON-COLLUSION AFFIDAVIT
(CUPCCAA PROJECTS UP TO \$200K)
(Must be submitted with bid)

STATE OF CALIFORNIA
COUNTY OF Ventura

I, Alan D Fletcher, being first duly sworn, deposes and
(Typed or Printed Name)
says that I am the President of Oilfield Electric Company,
(Title) *(Company Name)*
the party submitting the foregoing bid proposal (the "Bidder"). In connection with the foregoing
bid proposal ("Bid Proposal"), the undersigned declares, states and certifies that:

1. The Bid Proposal is not made in the interest of, or on behalf of, any undisclosed person, partnership, company, association, organization or corporation.
2. The Bid Proposal is genuine and not collusive or sham.
3. The Bidder has not directly or indirectly induced or solicited any other bidder to put in a false or sham bid, and has not directly or indirectly colluded, conspired, connived, or agreed with any other bidder or anyone else to put in sham bid, or to refrain from bidding.
4. The Bidder has not in any manner, directly or indirectly, sought by agreement, communication, or conference with anyone to fix the bid price, or that of any other bidder, or to fix any overhead, profit or cost element of the bid price or that of any other bidder, or to secure any advantage against the public body awarding the contract or of anyone interested in the proposed contract.
5. All statements contained in the Bid Proposal and related documents are true.
6. The Bidder has not, directly or indirectly, submitted the bid price or any breakdown thereof, or the contents thereof, or divulged information or data relative thereto, or paid, and will not pay, any fee to any person, corporation, partnership, company, association, organization, bid depository, or to any member or agent thereof to effectuate a collusive or sham bid.

Executed this 18th day of February, 2021 at Ventura, Ventura Co, California
(City, County and State)

I declare under penalty of perjury under the laws of the State of California that the foregoing is true and correct.

(Signature)

1801 N Ventura Ave
(Address)

Alan D Fletcher
(Name Printed or Typed)

Ventura, CA 93001
(City, State and Zip)

(805) 648-3131
(Area Code and Telephone Number)

info@oilfld.com
(Email)

END OF SECTION

(This page intentionally left blank)

SECTION 00222

**CERTIFICATION OF PREVAILING WAGE AND
RELATED LABOR REQUIREMENTS
(CUPCCAA PROJECTS UP TO \$200K)**

PROJECT/CONTRACT NO.: #21-01DO between Rio School District
("District") and Oilfield Electric Company ("Contractor"
or "Bidder") ("Contract" or "Project").

I hereby certify that I will conform to the State of California Public Works Contract requirements regarding prevailing wages, benefits, on-site audits with 48-hours notice, payroll records, and apprentice and trainee employment requirements, for all Work on the above Project including, without limitation, labor compliance monitoring and enforcement by the Department of Industrial Relations.

Date: 02/18/2021

Proper Name of Contractor: Oilfield Electric Company dba Oilfield Electric & Motor

Contractor Signature: 

Print Name: Alan D Fletcher

Title: President

(CUPCCAA PROJECT) Section 00222
Certification of Prevailing Wage and Related Labor Requirements
Generator Replacement at 1800 Solar
RSD Project #21-01DO

SECTION 00240

**ACKNOWLEDGMENT OF BIDDING
PRACTICES REGARDING INDEMNITY**

(CUPCCAA PROJECTS UP TO \$200K)

TO: Rio School District, 1800 Solar Dr. 3rd Floor, Oxnard, California 93030

RE: Project Number #21-1DO

Project Name Generator Replacement at 1800 Solar, Oxnard, Ca

Please be advised that with respect to the above-referenced Project, the undersigned Contractor, on behalf of itself and all subcontractors, hereby waives the benefits and protection of Labor Code Section 3864, which provides:

If an action as provided in this chapter prosecuted by the employee, the employer, or both jointly against the third person results in judgment against such third person, or settlement by such third person, the employer shall have no liability to reimburse or hold such third person harmless on such judgment or settlement in absence of a written agreement so to do executed prior to the injury.

This agreement has been signed by an authorized representative of the contracting party and shall be binding upon its successors and assigns. The undersigned further agrees to promptly notify the District of any changes of ownership of the contracting party or any subcontractor while this Agreement is in force.

Oilfield Electric Company dba Oilfield Electric & Motor

Contracting Party

Alan D Fletcher

Name of Agent/Title

02/18/2021

Date

END OF SECTION

SECTION 00210

BID FORM
(CUPCAA PROJECTS UP TO \$200K)

TO: RIO SCHOOL DISTRICT, a political subdivision of the State of California ("District"), acting by and through its Board of Trustees ("Board"), 1800 Solar Dr. 3rd Floor, Oxnard, CA 93030.

FROM: Venco Electric, Inc.
(Name of Bidder as listed on License)

Oxnard, CA 93030
(Address)
(City, State, Zip Code)

Jennifer Morris Secretary
(Telephone) *(FAX)*
(Name(s) of Bidder's Authorized Representative(s) & Title)

1. Bid.

1.1 Bid Amount. Pursuant to and in compliance with the Notice to Contractors Calling for Bids, the Instructions for Bidders and the other documents relating thereto, the undersigned bidder having reviewed the Instructions for Bidders and all other Contract Documents¹ and upon compliance with all requirements therein with reference to the submittal of this bid, hereby proposes and agrees to perform the Contract including, without limitation, all of its component parts; to perform everything required to be performed; to provide and furnish any and all of the labor, materials, tools, equipment, applicable taxes, and services necessary to perform the Contract and complete in a workmanlike manner all of the Work required for the CUPCAA Project described as: **Generator Replacement at 1800 Solar, Oxnard, Ca. RSD Project # 21-01DO** in accordance with the Contract Documents for the sum of:

"Total" Base Bid: Generator Replacement at 1800 Solar, Oxnard, Ca. RSD Project #21-01DO

One Hundred Thirty Thousand Dollars (\$) 130,000.⁰⁰
(Amount in Words) *(In Numbers)*

The undersigned bidder agrees to achieve Final Completion of the Work within the Contract Time set forth in the Contract Documents.

¹ Capitalized terms used herein shall have the same meanings as those set forth in the General Conditions, Section 700, unless otherwise defined herein.

1.2 Alternate Bid Items Proposal. Bidders must provide a proposal price for each additive or deductive alternate bid item set forth herein; failure to do so will result in rejection of the bid proposal for non-responsiveness. After the public opening and reading of the bids, the District will in its sole and exclusive discretion select all, some or none of the additive or deductive alternate bid items for inclusion in the Contract awarded hereunder. The foregoing notwithstanding, if the District elects to include some, but not all of the alternate bid items in the Contract to be awarded hereunder, the selection of such alternate bid items will be by priority, as follows:

Alternates are listed from the highest to lowest priority based on their numerical orders.

Add/Alternate Bid No. 1

NONE Dollars (\$)
(Amount in Words) (In Numbers)

1.3 Acknowledgment of Bid Addenda. In submitting this bid, the undersigned bidder acknowledges receipt of all bid addenda issued by or on behalf of the District, as set forth below. The bidder confirms that this bid incorporates and is inclusive of, all items or other matters contained in bid addenda.

Addenda No. (NONE), dated through No. , dated , received, acknowledged and incorporated into this bid.

1.4 Alternate Bid Items. The bidder's price proposal(s) for alternate bid items is/are set forth in the form of alternate bid item proposal included herewith. The bidder acknowledges that, in accordance with the Instruction for Bidders, the Contract for the Work may be awarded in the District's sole discretion with or without some, all or none of the alternate bid items being incorporated into the scope of the Contract awarded. The bidder further acknowledges that the District's selection of alternate bid items, if any, for inclusion in the Contract awarded will be in accordance with the Instructions for Bidders.

2. Rejection of Bid; Holding Open of Bid. It is understood that the District reserves the right to reject this bid and that this bid shall remain open and not be withdrawn for the period of time specified in the Call for Bids, except as provided by law.

3. Documents Comprising Bid. The undersigned bidder has submitted as its bid the following:

1. 00210 Bid Form
2. 00215 Designation of Subcontractors
3. 00218 Contractors Registration Certification (DIR)
4. 00220 Non-Collusion Affidavit
5. 00222 Certification of Prevailing Wage
6. 00230 Contractor's Statement of Experience
7. 00240 Acknowledgment of Bidding Practices Regarding Indemnity

The bidder acknowledges that if this bid is not fully in compliance with applicable requirements set forth in the Call for Bids, the Instructions for Bidders and in each of the foregoing documents, the bid may be rejected as non-responsive.

4. **Award of Contract.** It is understood and agreed that if written notice of the acceptance of this bid and award of the Contract thereon is mailed, telegraphed or delivered by the District to the undersigned after the opening of bids and within the time this bid is required to remain open or at any time thereafter before this bid is withdrawn, the undersigned will execute and deliver to the District the Agreement in the form attached hereto in accordance with the Bid as accepted within ten (10) calendar days after notification of acceptance and award. Concurrently with delivery of the executed Agreement to the District, the bidder awarded the Contract shall deliver to the District: (a) certificates of insurance evidencing all insurance coverage required under the Contract Documents; (b) the performance bond; (c) the labor and material payment bond; (d) the Certificate of Workers' Compensation Insurance; and (e) the drug-free workplace certificate. The Work under the Contract Documents shall be commenced by the undersigned bidder, if awarded the Contract, on the date stated in the District's Notice to Proceed issued pursuant to the Contract Documents and completion of the Work shall be achieved within the Contract Time specified in the Contract Documents.
5. **Notices.** All notices or other correspondence shall be addressed to the District and the bidder at their respective addresses set forth herein. Notices shall be effective only if in writing and in conformity with the requirements for service of notices set forth in the Contract Documents.
6. **Contractor's License.** The undersigned Bidder is currently and duly licensed in accordance with the California Contractors License Law, California Business & Professions Code §§ 7000, *et seq.*, under the following:

License Number: 446770
Class C-10 Expiration date 9/30/21 Class _____ Expiration date _____
Class _____ Expiration date _____ Class _____ Expiration date _____

By executing this bid, the bidder hereby certifies that: (a) it is duly licensed, in the necessary class(es), for performing the Work of the Contract Documents; (b) that such license shall be in full force and effect throughout the duration of the performance of the Work under the Contract Documents; and (c) that all Subcontractors providing or performing any portion of the Work of the Contract Documents shall be so similarly and appropriately licensed to perform or provide such portion of the Work.

7. **Designation of Subcontractors.** In compliance with the Subletting and Subcontracting Fair Practices Act (California Public Contract Code §§ 4100, *et seq.*) and amendments thereof, each bidder shall set forth in the Subcontractors List: (a) the name and location/address of the place of business of each Subcontractor who will perform work or labor or render services to the bidder in or about the construction of the Work to be performed under the Contract Documents in an amount in excess of one-half of one percent (0.005%) of the bidder's bid; and (b) the portion of the Work which will be performed by each listed Subcontractor. The bidder shall list only one Subcontractor for each portion of

the Work as is defined by the bidder in its bid. If a bidder fails to list a Subcontractor or if the bidder specifies more than one Subcontractor for the same portion of Work to be performed under the Contract Documents valued in excess of one-half of one percent (0.005%) of the bidder's bid amount, the bidder shall be deemed to have agreed that it is "fully qualified" to perform that portion of the Work itself and that it shall perform that portion of the Work.

(In addition, refer to Specification Section 00100 Instruction to Bidders, Section 21 Subcontractors, Sub Section 21.1 Designation of Subcontractors; Subcontractors list of the contract documents.)

8. **Confirmation of Figures.** By submitting this bid, the bidder confirms that it has checked all of the above figures and understands that neither the District nor any of its agents, employees or representatives shall be responsible for any errors or omissions on the part of the undersigned bidder in preparing and submitting this bid.

9. **Acknowledgment and Confirmation.** The undersigned bidder acknowledges its receipt, review and understanding of the Drawings, the Specifications and other Contract Documents pertaining to the proposed Work. The undersigned bidder certifies that the Contract Documents are, in its opinion, adequate, feasible and complete for providing, performing and constructing the Work in a sound and suitable manner for the use specified and intended by the Contract Documents. The undersigned bidder certifies that it has, or as available, all necessary equipment, personnel, materials, facilities and technical and financial ability to complete the Work for the amount bid herein within the Contract Time and in accordance with the Contract Documents.

(Corporate Seal)



Signature of Bidder's Authorized Representative

Jennifer Morris

Typed or Printed Name

Secretary

Title

E-mail Address of Bidder's Authorized Representative

Department of Industrial Relations Registration Number

2-19-21

Date

END OF SECTION

SECTION 00215

DESIGNATION OF SUBCONTRACTORS (CUPCCAA PROJECTS UP TO \$200K)

(Must be submitted with bid)

1. In compliance with the Subletting and Subcontracting Fair Practices Act (Government Code Section 4100, *et seq.*) and any amendments thereof, each bidder shall set forth below:
 - a. The name and the location of the place of business of each services to the prime contractor in or about the construction of the work or improvement to be performed under this contract in an amount in excess of one-half of one percent (0.005%) of the prime contractor's total bid, and
 - b. The portion of the work which will be done by each subcontractor under this act. The prime contractor shall list only one subcontractor for each portion as is defined by the prime contractor in this bid.
2. If a prime contractor fails to specify a subcontractor or if a prime contractor specifies more than one subcontractor for the same portion of work to be performed under the contract in excess of one-half of one percent (0.005%) of the prime contractor's total bid, the prime contractor shall be deemed to have agreed to be fully qualified to perform that portion of work, and that it shall be performed by the contractor.
3. No prime contractor whose bid is accepted shall:
 - a. Substitute any subcontractor without written approval by the District,
 - b. Permit any subcontract to be voluntarily assigned or transferred or allow it to be performed by anyone other than the original subcontractor listed in the original bid,
 - c. Sublet or subcontract any portion of the work in excess of one-half of one percent of the prime contractor's total bid as was originally bid and did not designate a subcontractor, except as authorized in the Subletting and Subcontracting Fair Practices Act.

Subletting or subcontracting of any portion of the work in excess of one-half of one percent (0.005%) of the prime contractor's total bid as to which subcontractor was designated in the original bid shall only be permitted to cases of public emergency or necessity, and then only after a finding reduced to writing as public record of the authority awarding this contract, setting forth the facts constituting the emergency or necessity.

NOTE: If alternate bids are called for and bidder intends to use different or additional subcontractors on the alternates, a separate list of subcontractors must be provided for each such alternate.

4. **MANDATORY REGISTRATION WITH THE DEPARTMENT OF INDUSTRIAL RELATIONS** - Senate Bill 854 requires ALL contractors and subcontractors submitting bids on public works projects to be registered with the Department of Industrial Relations ("DIR") for purposes of labor compliance. All contractors and subcontractors must submit proof of valid, accurate, and current DIR registration with their bid. Rio School District will not accept bids from any contractors or subcontractors who are not registered with the DIR at the time the bid is submitted. Any contractors or subcontractors submitting a bid without being registered with the DIR at the time of bid will have their bid rejected as being non responsive. All contractors must affirmatively acknowledge their obligation not to hire subcontractors who lack an accurate, valid DIR registration number.

SUBCONTRACTOR LIST

Subcontractor's Licensed Name and DIR Registration Number (Required)	Subcontractor Valid License Number (Required)	Complete address of Subcontractor's Office, Mill or Shop (Required)	Subcontractor's Trade or Portion of Work (Required)
Draper Contractors Inc. 1000063347	1033059	PO BOX 751 Somis, CA 93066	concrete

Name of Bidder: Venco Electric, Inc.
 Authorized Signature: [Signature]

END OF SECTION

**SECTION 00218
CERTIFICATION OF CONTRACTOR AND
SUBCONTRACTOR DIVISION OF INDUSTRIAL RELATIONS REGISTRATION
(DIR)
(CUPCCAA PROJECTS UP TO \$200K)**

Pursuant to Public Contract Code Section 1725.5, a contractor or subcontractor must be registered with the Department of Industrial relations in order to bid on, to be listed in a bid proposal or to engage in the performance of any defined public work contract.

I Jennifer Morris Secretary certify that
(Name) (Title)
Venco Electric, Inc. is currently registered as a contractor with the Department of Industrial
(Contractor Name)

Relations (DIR):

Contractor's DIR Registration Number 00000000

Expiration date June 30, 2021

Contract further acknowledges:

1. Contractor shall maintain DIR registered status for the duration of the project without a gap in registration.
2. Contractor shall note in its invitation to bid the DIR's registration requirement for all subcontractors and their subcontractors.
3. Contractor shall ensure that all subcontractors are registered at time of bid opening and maintain registered status for the duration of the project.
4. Contractor is to furnish DIR Registration Number for all subcontractors on the project within 24 hours of the bid opening.
5. Contractor shall substitute any subcontractor with a DIR registered contractor if listed subcontractor is unable to perform the work.

Failure to comply with any of the above may result in a determination of non-responsiveness.

I declare under penalty of perjury under California law that the foregoing is true and correct.

Jennifer Morris
Signature
2-19-21
Date

(CUPCCAA PROJECT) SECTION 00218
CERTIFICATION OF CONTRACTOR AND SUBCONTRACTOR DIVISION OF INDUSTRIAL RELATIONS
REGISTRATION
Generator Replacement at 1800 Solar
RSD Project # 21-01DO

SECTION 00220

**NON-COLLUSION AFFIDAVIT
(CUPCAA PROJECTS UP TO \$200K)**
(Must be submitted with bid)

STATE OF CALIFORNIA
COUNTY OF VENTURA

I, Jennifer Morris, being first duly sworn, deposes and
(Typed or Printed Name)
says that I am the Secretary of Venco Electric, Inc.
(Title) *(Company Name)*

the party submitting the foregoing bid proposal (the "Bidder"). In connection with the foregoing bid proposal ("Bid Proposal"), the undersigned declares, states and certifies that:

1. The Bid Proposal is not made in the interest of, or on behalf of, any undisclosed person, partnership, company, association, organization or corporation.
2. The Bid Proposal is genuine and not collusive or sham.
3. The Bidder has not directly or indirectly induced or solicited any other bidder to put in a false or sham bid, and has not directly or indirectly colluded, conspired, connived, or agreed with any other bidder or anyone else to put in sham bid, or to refrain from bidding.
4. The Bidder has not in any manner, directly or indirectly, sought by agreement, communication, or conference with anyone to fix the bid price, or that of any other bidder, or to fix any overhead, profit or cost element of the bid price or that of any other bidder, or to secure any advantage against the public body awarding the contract or of anyone interested in the proposed contract.
5. All statements contained in the Bid Proposal and related documents are true.
6. The Bidder has not, directly or indirectly, submitted the bid price or any breakdown thereof, or the contents thereof, or divulged information or data relative thereto, or paid, and will not pay, any fee to any person, corporation, partnership, company, association, organization, bid depository, or to any member or agent thereof to effectuate a collusive or sham bid.

Executed this 19 day of Feb, 2021 at Oxnard, Ventura, CA
(City, County and State)

I declare under penalty of perjury under the laws of the State of California that the foregoing is true and correct.

Jennifer Morris
(Signature)
Jennifer Morris
(Name Printed or Typed)

Oxnard, CA 93030
(Address)
Oxnard, CA 93030
(City, State and Zip)

(Area Code and Telephone Number)

(Email)

END OF SECTION

(This page intentionally left blank)

SECTION 00222

**CERTIFICATION OF PREVAILING WAGE AND
RELATED LABOR REQUIREMENTS
(CUPCAA PROJECTS UP TO \$200K)**

PROJECT/CONTRACT NO.: 21-01DO between Rio School District
("District") and Venco Electric, Inc. ("Contractor"
or "Bidder") ("Contract" or "Project").

I hereby certify that I will conform to the State of California Public Works Contract requirements regarding prevailing wages, benefits, on-site audits with 48-hours notice, payroll records, and apprentice and trainee employment requirements, for all Work on the above Project including, without limitation, labor compliance monitoring and enforcement by the Department of Industrial Relations.

Date: 2-19-21
Proper Name of Contractor: Venco Electric, Inc.
Contractor Signature: Jennifer M
Print Name: Jennifer Morris
Title: Secretary

SECTION 00240

**ACKNOWLEDGMENT OF BIDDING
PRACTICES REGARDING INDEMNITY**

(CUPCCAA PROJECTS UP TO \$200K)

TO: **Rio School District, 1800 Solar Dr. 3rd Floor, Oxnard, California 93030**

RE: Project Number 21-01DO

Project Name Generator Replacement at 1800 Solar

Please be advised that with respect to the above-referenced Project, the undersigned Contractor, on behalf of itself and all subcontractors, hereby waives the benefits and protection of Labor Code Section 3864, which provides:

If an action as provided in this chapter prosecuted by the employee, the employer, or both jointly against the third person results in judgment against such third person, or settlement by such third person, the employer shall have no liability to reimburse or hold such third person harmless on such judgment or settlement in absence of a written agreement so to do executed prior to the injury.

This agreement has been signed by an authorized representative of the contracting party and shall be binding upon its successors and assigns. The undersigned further agrees to promptly notify the District of any changes of ownership of the contracting party or any subcontractor while this Agreement is in force.

Venco Electric, Inc.
Contracting Party

Jennifer Morris / Secretary
Name of Agent/Title

2-19-21
Date

END OF SECTION

Rio School District
1800 Solar, 3rd Floor
Oxnard, CA 93036
Attn: Dr. John Puglisi, Superintendent

February 24, 2021

Subject: Request for Board Approval to Award Joint Project at District Office (Rio/OUHSD)

Re: RSD Project #21-01DO Generator Replacement at 1800 Solar, Oxnard, Ca.
Recommendation to Award to the Lowest Responsive Bidder

Dear Dr. Puglisi,

The Rio School District received bids for RSD Project #21-01DO Generator Replacement at 1800 Solar, Oxnard, Ca.
The following company's submitted bids in the order listed. This Project is tentatively scheduled to be completed by May 10, 2021.

CONTRACTOR	BASE BID	Add Alternate (Not accepted)	Total Bid
<i>Oilfield Electric</i>	\$111,750.00	n/a	\$111,750.00
Venco	\$130,000.00	n/a	\$130,000.00

It is our recommendation that the Superintendent of Schools, per authorization by the Board of Education at its March 17, 2021 board meeting, proceed with issuing a Notice of Award to Oilfield Electric.

Should you have any questions or require any additional information, please contact me at any time.

Respectfully,

KH 2/24/2021

Keith Henderson
Senior Project Manager, Balfour Beatty Construction

cc. Wael Saleh Rio S.D.
Dennis Kuykendall BBC
Jesus Meugerza Ibarra BBC

10.17



Agenda Item Details

Meeting	Mar 17, 2021 - RSD Regular Board Meeting
Category	10. Consent
Subject	10.17 Approval to Bid Rio School District Projects 21-08L, 21-09L, and 21-10L for the new fire alarm projects at Rio Real, Rio Plaza, and Rio Del Valle.
Access	Public
Type	Action (Consent)
Recommended Action	It is recommended that the Board approve the Request to Bid Rio School District Projects 21-08L, 21-09L, and 21-10L for the new fire alarm projects at Rio Real, Rio Plaza, and Rio Del Valle.

Public Content

Speaker: Wael Saleh, Assistant Superintendent, Business Services

Rationale:

This request is to Bid Rio School District Projects 21-08L, 21-09L, and 21-10L for the new fire alarm projects at Rio Real, Rio Plaza, and Rio Del Valle. Each of the projects have already received DSA approval of the plans. For the Safety of Students, staff and the public while occupying these campuses Balfour Beatty recommends that the Board approve Balfour Beatty to solicit bids.

[21-08L Request for Board Approval to Bid Project \(3\).pdf \(35 KB\)](#)

Administrative Content

Executive Content

Our adopted rules of Parliamentary Procedure, Robert's Rules, provide for a consent agenda listing several items for approval of the Board by a single motion. Most of the items listed under the consent agenda have gone through Board subcommittee review and recommendation. Documentation concerning these items has been provided to all Board members and the public in advance to assure an extensive and thorough review. Items may be removed from the consent agenda at the request of any board member.

Rio School District
1800 Solar, 3rd Floor
Oxnard, CA 93036
Attn; Dr. John Puglisi, Superintendent

March 2, 2021

Subject: Request for Board Approval to Bid Fire Alarm Projects at Rio Plaza, Rio Real & Rio Del Valle

Re: Request Board Approval to Issue/Advertise & Solicit Bids for RSD Project #21-08L Campus Wide Fire Alarm @ Rio Plaza, RSD Project #21-09L Campus Wide Fire Alarm @ Rio Real and RSD Project #21-10L Campus Wide Fire Alarm at Rio Del Valle.

Dear Members of the Rio School District Board of Education and Dr. Puglisi,

Balfour Beatty Construction would like to obtain approval from the Rio School Districts Board of Education and Superintendent of the District to move forward with assembling bids, and solicit Contractors for the following Construction projects related to Fire/Life Safety at 3 Rio School District campuses that are desperately in need of a Fire Alarm System Replacement.

Balfour Beatty Construction is requesting Approval to Solicit Bids for the following Projects:

- 1) RSD Project #21-08L Campus Wide Fire Alarm at Rio Plaza Elementary School. Estimated Budget to Construct of \$385,000.00
- 2) RSD Project #21-09L Campus Wide Fire Alarm at Rio Real Elementary School. Estimated Budget to Construct of \$395,000.00
- 3) RSD Project #21-10L Campus Wide Fire Alarm at Rio Del Valle Middle School. Estimated Budget to Construct of \$390,000.00

Each of the Projects above that we have requested approval to bid all have DSA Approved plans on standby. Balfour Beatty is of the opinion that it is in the best interest of the Rio School District to approve and move forward with these very important projects for the Safety of Students, Staff, and the Public while occupying these campuses.

It is therefore Balfour Beatty Constructions recommendation that the Rio School District Board of Education and the Superintendent of Schools Issue an Approval to Solicit and Bid these 3 fire alarm projects.

Should you have any questions or require any additional information, please contact me at any time.

Respectfully,

KH 3/2/2021

Keith Henderson
Senior Project Manager, Balfour Beatty Construction

cc. Wael Saleh Rio S.D.
Dennis Kuykendall BBC
Jesus Meugerza Ibarra BBC

10.18



Agenda Item Details

Meeting	Mar 17, 2021 - RSD Regular Board Meeting
Category	10. Consent
Subject	10.18 Approval of Award of Bid received for Project #21-03L, Modular Classroom Building Electrical Service at Rio Del Valle from Taft Electric
Access	Public
Type	Action (Consent)
Fiscal Impact	Yes
Dollar Amount	209,900.00
Budgeted	Yes
Budget Source	Measure L Funds
Recommended Action	It is recommended that the Board approve the Award of Bid for the Modular Classroom Building Electric Service at Rio Del Valle be awarded to Taft Electric

Public Content

Speaker:
Wael Saleh, Assistant Superintendent, Business Services

Rationale:

Taft Electric submitted a bid for \$209,900 for the Electrical service to the Modular Classroom Building at Rio Del Valle. We believe this proposal and bid amount is within budget.

TOTAL BID PACKAGE RIO SCHOOLS, 21-03L (1).pdf (1,631 KB)

21-03L TAFT Recommendation to award 3 4 2021 (1) (1).pdf (63 KB)

Administrative Content

Executive Content

Our adopted rules of Parliamentary Procedure, Robert's Rules, provide for a consent agenda listing several items for approval of the Board by a single motion. Most of the items listed under the consent agenda have gone through Board subcommittee review and recommendation. Documentation concerning these items has been provided to all Board

SECTION 00210

BID FORM
(CUPCCAA PROJECTS UP TO \$200K)

TO: RIO SCHOOL DISTRICT, a political subdivision of the State of California ("District"), acting by and through its Board of Trustees ("Board"), 1800 Solar Dr. 3rd Floor, Oxnard, CA 93030.

FROM: Taft Electric Company
(Name of Bidder as listed on License)
Ave.
(Address) 3
(City, State, Zip Code) 7925
(Telephone) (FAX)
Mark Tovias, Service Department Manager
(Name(s) of Bidder's Authorized Representative(s) & Title)

1. Bid.

1.1 Bid Amount. Pursuant to and in compliance with the Notice to Contractors Calling for Bids, the Instructions for Bidders and the other documents relating thereto, the undersigned bidder having reviewed the Instructions for Bidders and all other Contract Documents¹ and upon compliance with all requirements therein with reference to the submittal of this bid, hereby proposes and agrees to perform the Contract including, without limitation, all of its component parts; to perform everything required to be performed; to provide and furnish any and all of the labor, materials, tools, equipment, applicable taxes, and services necessary to perform the Contract and complete in a workmanlike manner all of the Work required for the CUPCCAA Project described as: **Modular Classroom Building Electrical Service RDV. RSD Project # 21-03L** in accordance with the Contract Documents for the sum of:

"Total" Base Bid: Modular Classroom Building Electrical Service RDV. RSD Project #21-03L

Two hundred nine thousand, nine hundred Dollars (\$ 209,900)
(Amount in Words) (In Numbers)

The undersigned bidder agrees to achieve Final Completion of the Work within the Contract Time set forth in the Contract Documents.

¹ Capitalized terms used herein shall have the same meanings as those set forth in the General Conditions, Section 700, unless otherwise defined herein.

1.2 Alternate Bid Items Proposal. Bidders must provide a proposal price for each additive or deductive alternate bid item set forth herein; failure to do so will result in rejection of the bid proposal for non-responsiveness. After the public opening and reading of the bids, the District will in its sole and exclusive discretion select all, some or none of the additive or deductive alternate bid items for inclusion in the Contract awarded hereunder. The foregoing notwithstanding, if the District elects to include some, but not all of the alternate bid items in the Contract to be awarded hereunder, the selection of such alternate bid items will be by priority, as follows:

Alternates are listed from the highest to lowest priority based on their numerical orders.

Add/Alternate Bid No. 1

NONE Dollars (\$)
(Amount in Words) (In Numbers)

1.3 Acknowledgment of Bid Addenda. In submitting this bid, the undersigned bidder acknowledges receipt of all bid addenda issued by or on behalf of the District, as set forth below. The bidder confirms that this bid incorporates and is inclusive of, all items or other matters contained in bid addenda.

Addenda No. 1, dated 2/24/21 through No. 2, dated 3/2/21, received, acknowledged and incorporated into this bid.

1.4 Alternate Bid Items. The bidder's price proposal(s) for alternate bid items is/are set forth in the form of alternate bid item proposal included herewith. The bidder acknowledges that, in accordance with the Instruction for Bidders, the Contract for the Work may be awarded in the District's sole discretion with or without some, all or none of the alternate bid items being incorporated into the scope of the Contract awarded. The bidder further acknowledges that the District's selection of alternate bid items, if any, for inclusion in the Contract awarded will be in accordance with the Instructions for Bidders.

2. Rejection of Bid; Holding Open of Bid. It is understood that the District reserves the right to reject this bid and that this bid shall remain open and not be withdrawn for the period of time specified in the Call for Bids, except as provided by law.

3. Documents Comprising Bid. The undersigned bidder has submitted as its bid the following:

1. 00210 Bid Form
2. 00215 Designation of Subcontractors
3. 00218 Contractors Registration Certification (DIR)
4. 00220 Non-Collusion Affidavit
5. 00222 Certification of Prevailing Wage
6. 00230 Contractor's Statement of Experience
7. 00240 Acknowledgment of Bidding Practices Regarding Indemnity

The bidder acknowledges that if this bid is not fully in compliance with applicable requirements set forth in the Call for Bids, the Instructions for Bidders and in each of the foregoing documents, the bid may be rejected as non-responsive.

4. **Award of Contract.** It is understood and agreed that if written notice of the acceptance of this bid and award of the Contract thereon is mailed, telegraphed or delivered by the District to the undersigned after the opening of bids and within the time this bid is required to remain open or at any time thereafter before this bid is withdrawn, the undersigned will execute and deliver to the District the Agreement in the form attached hereto in accordance with the Bid as accepted within ten (10) calendar days after notification of acceptance and award. Concurrently with delivery of the executed Agreement to the District, the bidder awarded the Contract shall deliver to the District: (a) certificates of insurance evidencing all insurance coverage required under the Contract Documents; (b) the performance bond; (c) the labor and material payment bond; (d) the Certificate of Workers' Compensation Insurance; and (e) the drug-free workplace certificate. The Work under the Contract Documents shall be commenced by the undersigned bidder, if awarded the Contract, on the date stated in the District's Notice to Proceed issued pursuant to the Contract Documents and completion of the Work shall be achieved within the Contract Time specified in the Contract Documents.
5. **Notices.** All notices or other correspondence shall be addressed to the District and the bidder at their respective addresses set forth herein. Notices shall be effective only if in writing and in conformity with the requirements for service of notices set forth in the Contract Documents.
6. **Contractor's License.** The undersigned Bidder is currently and duly licensed in accordance with the California Contractors License Law, California Business & Professions Code §§ 7000, *et seq.*, under the following:

License Number: 772245
Class A, B, C10 Expiration date 12/31/21 Class _____ Expiration date _____
Class _____ Expiration date _____ Class _____ Expiration date _____

By executing this bid, the bidder hereby certifies that: (a) it is duly licensed, in the necessary class(es), for performing the Work of the Contract Documents; (b) that such license shall be in full force and effect throughout the duration of the performance of the Work under the Contract Documents; and (c) that all Subcontractors providing or performing any portion of the Work of the Contract Documents shall be so similarly and appropriately licensed to perform or provide such portion of the Work.

7. **Designation of Subcontractors.** In compliance with the Subletting and Subcontracting Fair Practices Act (California Public Contract Code §§ 4100, *et seq.*) and amendments thereof, each bidder shall set forth in the Subcontractors List: (a) the name and location/address of the place of business of each Subcontractor who will perform work or labor or render services to the bidder in or about the construction of the Work to be performed under the Contract Documents in an amount in excess of one-half of one percent (0.005%) of the bidder's bid; and (b) the portion of the Work which will be performed by each listed Subcontractor. The bidder shall list only one Subcontractor for each portion of

the Work as is defined by the bidder in its bid. If a bidder fails to list a Subcontractor or if the bidder specifies more than one Subcontractor for the same portion of Work to be performed under the Contract Documents valued in excess of one-half of one percent (0.005%) of the bidder's bid amount, the bidder shall be deemed to have agreed that it is "fully qualified" to perform that portion of the Work itself and that it shall perform that portion of the Work.

(In addition, refer to Specification Section 00100 Instruction to Bidders, Section 21 Subcontractors, Sub Section 21.1 Designation of Subcontractors; Subcontractors list of the contract documents.)

8. **Confirmation of Figures.** By submitting this bid, the bidder confirms that it has checked all of the above figures and understands that neither the District nor any of its agents, employees or representatives shall be responsible for any errors or omissions on the part of the undersigned bidder in preparing and submitting this bid.
9. **Acknowledgment and Confirmation.** The undersigned bidder acknowledges its receipt, review and understanding of the Drawings, the Specifications and other Contract Documents pertaining to the proposed Work. The undersigned bidder certifies that the Contract Documents are, in its opinion, adequate, feasible and complete for providing, performing and constructing the Work in a sound and suitable manner for the use specified and intended by the Contract Documents. The undersigned bidder certifies that it has, or as available, all necessary equipment, personnel, materials, facilities and technical and financial ability to complete the Work for the amount bid herein within the Contract Time and in accordance with the Contract Documents.

(Corporate Seal)

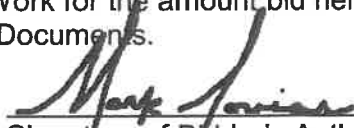

Signature of Bidder's Authorized Representative

Mark Tovias

Typed or Printed Name

Service Department Manager

Title

om

E-mail Address of Bidder's Authorized Representative

Department of Industrial Relations Registration Number

3/3/21

Date

END OF SECTION

SECTION 00215

DESIGNATION OF SUBCONTRACTORS (CUPCCAA PROJECTS UP TO \$200K)

(Must be submitted with bid)

1. In compliance with the Subletting and Subcontracting Fair Practices Act (Government Code Section 4100, *et seq.*) and any amendments thereof, each bidder shall set forth below:
 - a. The name and the location of the place of business of each services to the prime contractor in or about the construction of the work or improvement to be performed under this contract in an amount in excess of one-half of one percent (0.005%) of the prime contractor's total bid, and
 - b. The portion of the work which will be done by each subcontractor under this act. The prime contractor shall list only one subcontractor for each portion as is defined by the prime contractor in this bid.
2. If a prime contractor fails to specify a subcontractor or if a prime contractor specifies more than one subcontractor for the same portion of work to be performed under the contract in excess of one-half of one percent (0.005%) of the prime contractor's total bid, the prime contractor shall be deemed to have agreed to be fully qualified to perform that portion of work, and that it shall be performed by the contractor.
3. No prime contractor whose bid is accepted shall:
 - a. Substitute any subcontractor without written approval by the District,
 - b. Permit any subcontract to be voluntarily assigned or transferred or allow it to be performed by anyone other than the original subcontractor listed in the original bid,
 - c. Sublet or subcontract any portion of the work in excess of one-half of one percent of the prime contractor's total bid as was originally bid and did not designate a subcontractor, except as authorized in the Subletting and Subcontracting Fair Practices Act.

Subletting or subcontracting of any portion of the work in excess of one-half of one percent (0.005%) of the prime contractor's total bid as to which subcontractor was designated in the original bid shall only be permitted to cases of public emergency or necessity, and then only after a finding reduced to writing as public record of the authority awarding this contract, setting forth the facts constituting the emergency or necessity.

NOTE: If alternate bids are called for and bidder intends to use different or additional subcontractors on the alternates, a separate list of subcontractors must be provided for each such alternate.

4. **MANDATORY REGISTRATION WITH THE DEPARTMENT OF INDUSTRIAL RELATIONS** - Senate Bill 854 requires ALL contractors and subcontractors submitting bids on public works projects to be registered with the Department of Industrial Relations (“DIR”) for purposes of labor compliance. All contractors and subcontractors must submit proof of valid, accurate, and current DIR registration with their bid. Rio School District will not accept bids from any contractors or subcontractors who are not registered with the DIR at the time the bid is submitted. Any contractors or subcontractors submitting a bid without being registered with the DIR at the time of bid will have their bid rejected as being non responsive. All contractors must affirmatively acknowledge their obligation not to hire subcontractors who lack an accurate, valid DIR registration number.

SUBCONTRACTOR LIST			
Subcontractor's Licensed Name and DIR Registration Number (Required)	Subcontractor Valid License Number (Required)	Complete address of Subcontractor's Office, Mill or Shop (Required)	Subcontractor's Trade or Portion of Work (Required)
Richard Reed Backhoe	-----		operating engineer
Wright Sawing & Breaking	507		Laborer

Name of Bidder: Mark Tovias

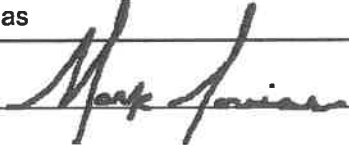
Authorized Signature: 

END OF SECTION

**SECTION 00218
CERTIFICATION OF CONTRACTOR AND
SUBCONTRACTOR DIVISION OF INDUSTRIAL RELATIONS REGISTRATION
(DIR)
(CUPCCAA PROJECTS UP TO \$200K)**

Pursuant to Public Contract Code Section 1725.5, a contractor or subcontractor must be registered with the Department of Industrial relations in order to bid on, to be listed in a bid proposal or to engage in the performance of any defined public work contract.

I Mark Tovias, Service Department Manager certify that
(Name) (Title)

the Taft Electric Company is currently registered as a contractor with the Department of Industrial
(Contractor Name)

Relations (DIR):

Contractor's DIR Registration Number _____

Expiration date June 30, 2021

Contract further acknowledges:

1. Contractor shall maintain DIR registered status for the duration of the project without a gap in registration.
2. Contractor shall note in its invitation to bid the DIR's registration requirement for all subcontractors and their subcontractors.
3. Contractor shall ensure that all subcontractors are registered at time of bid opening and maintain registered status for the duration of the project.
4. Contractor is to furnish DIR Registration Number for all subcontractors on the project within 24 hours of the bid opening.
5. Contractor shall substitute any subcontractor with a DIR registered contractor if listed subcontractor is unable to perform the work.

Failure to comply with any of the above may result in a determination of non-responsiveness.

I declare under penalty of perjury under California law that the foregoing is true and correct.

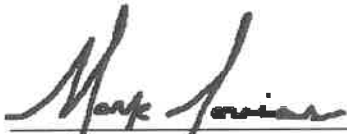

Signature

3/3/21

Date

SECTION 00220

NON-COLLUSION AFFIDAVIT
(CUPCCAA PROJECTS UP TO \$200K)
(Must be submitted with bid)

STATE OF CALIFORNIA
COUNTY OF Ventura

I, Mark Tovias, being first duly sworn, deposes and
says that I am the Service Department Manager of Taft Electric Company
the party submitting the foregoing bid proposal (the "Bidder"). In connection with the foregoing
bid proposal ("Bid Proposal"), the undersigned declares, states and certifies that:

- 1. The Bid Proposal is not made in the interest of, or on behalf of, any undisclosed
person, partnership, company, association, organization or corporation.
2. The Bid Proposal is genuine and not collusive or sham.
3. The Bidder has not directly or indirectly induced or solicited any other bidder to
put in a false or sham bid, and has not directly or indirectly colluded, conspired,
connived, or agreed with any other bidder or anyone else to put in sham bid, or
to refrain from bidding.
4. The Bidder has not in any manner, directly or indirectly, sought by agreement,
communication, or conference with anyone to fix the bid price, or that of any
other bidder, or to fix any overhead, profit or cost element of the bid price or that
of any other bidder, or to secure any advantage against the public body awarding
the contract or of anyone interested in the proposed contract.
5. All statements contained in the Bid Proposal and related documents are true.
6. The Bidder has not, directly or indirectly, submitted the bid price or any
breakdown thereof, or the contents thereof, or divulged information or data
relative thereto, or paid, and will not pay, any fee to any person, corporation,
partnership, company, association, organization, bid depository, or to any
member or agent thereof to effectuate a collusive or sham bid.

Executed this 3rd day of MARCH, 2021 at Ventura, Ventura County, California
(City, County and State)

I declare under penalty of perjury under the laws of the State of California that the foregoing is
true and correct.

Mark Tovias
(Signature)

(Address)

Mark Tovias
(Name Printed or Typed)

Ventura, CA. 93003
(City, State and Zip)

(Area Code and Telephone Number)

(Email)

END OF SECTION

(This page intentionally left blank)

SECTION 00222

**CERTIFICATION OF PREVAILING WAGE AND
RELATED LABOR REQUIREMENTS
(CUPCCAA PROJECTS UP TO \$200K)**

PROJECT/CONTRACT NO.: RSD Project #21-03L between _____
("District") and Taft Electric Company ("Contractor"
or "Bidder") ("Contract" or "Project").

I hereby certify that I will conform to the State of California Public Works Contract requirements regarding prevailing wages, benefits, on-site audits with 48-hours notice, payroll records, and apprentice and trainee employment requirements, for all Work on the above Project including, without limitation, labor compliance monitoring and enforcement by the Department of Industrial Relations.

Date: 3/3/21

Proper Name of Contractor: Taft Electric Company

Contractor Signature: 

Print Name: Mark Tovias

Title: Service Department Manager

SECTION 00240

**ACKNOWLEDGMENT OF BIDDING
PRACTICES REGARDING INDEMNITY**

(CUPCAA PROJECTS UP TO \$200K)

TO: Rio School District, 1800 Solar Dr. 3rd Floor, Oxnard, California 93030

RE: Project Number #21-03L

Project Name RSD Project #21-03L Modular Classroom Building Electrical Service RDV

Please be advised that with respect to the above-referenced Project, the undersigned Contractor, on behalf of itself and all subcontractors, hereby waives the benefits and protection of Labor Code Section 3864, which provides:

If an action as provided in this chapter prosecuted by the employee, the employer, or both jointly against the third person results in judgment against such third person, or settlement by such third person, the employer shall have no liability to reimburse or hold such third person harmless on such judgment or settlement in absence of a written agreement so to do executed prior to the injury.

This agreement has been signed by an authorized representative of the contracting party and shall be binding upon its successors and assigns. The undersigned further agrees to promptly notify the District of any changes of ownership of the contracting party or any subcontractor while this Agreement is in force.

Taft Electric Company

Contracting Party

Mark Tovias Service Department Manager

Name of Agent/Title

3/3/21

Date

END OF SECTION

TAFT ELECTRIC COMPANY

ELECTRICAL CONTRACTORS

STATE LICENSE NO. 772245

P. O. BOX 3416 - 1694 EASTMAN AVENUE - VENTURA, CALIFORNIA 93003 - (805) 642-0121 - FAX (805) 650-9015

ELECTRICAL PROPOSAL & SCOPE OF WORK

BALFOUR BEATTY, "RIO DEL VALLE PORTABLE CLASSROOM RELOCATION"-BID #1397

February 26, 2021

We are pleased to present our scope of work and proposal for the above project. We are a union Contractor, California Contractor's License #772245/C-10. Taft Electric Company will furnish and install the electrical material required per job walk. Our price for this work, including Taft Electric's qualifications and exclusions listed below is as follows:

BASE BID ELECTRICAL..... \$209,900

SCOPE OF WORK:

Install electrical, data and fire alarm as per bid sheets E1-E5.1 and per Addendum #2

QUALIFICATIONS:

Bid based on work performed during normal working hours of 6am-3pm Monday through Friday
Overtime, weekend, and holiday rates do not apply
Directional drilling to be used to route conduit from main gear to portables as per plan sheet E2
Cat6 cable to be used to supply internet source as per sheet E3 note 5
BOTH ADDENDUM #'S 1 & 2 HAVE BEEN RECIEVED

EXCLUSIONS:

1. HVAC and EMS equipment, devices, low voltage wire and terminations
2. Access panels, fire rated fixtures and cabinet enclosures
3. All formed and finished concrete, housekeeping pads, and conduit curbs
4. Slack and seismic wires for recessed fixtures, surface fixtures and ceiling devices
5. All additional seismic and or structural support, engineering, and upgrades
6. MEP design engineering coordination requirements, cost, and labor
7. CA Title 24 design, engineering and regulatory requirements and cost
8. SWPPP, implementation, installation, cost, and fees
9. New light fixtures
10. Cost of a bond, we are bondable at an adder of 1%
11. Painting, patching and drywall repair
12. Temporary power and lighting
13. All permit costs and fees.
14. Utility charges and fees.
15. Surveying and staking.

If you have any questions, please do not hesitate to contact the undersigned.

Sincerely,



Mark Tovias
TAFT ELECTRIC COMPANY
Service Department Manager
mtovias@taftelectric.com

Authorization to start work based
on bid amount listed above:

Signature: _____

Printed name: _____

Date: _____

Rio School District
1800 Solar, 3rd Floor
Oxnard, CA 93036
Attn: Dr. John Puglisi, Superintendent

March 4, 2021

Subject: Request for Board Approval to Award Project

Re: RSD Project #21-03L Modular Classroom Building Electrical Service RDV, Oxnard, Ca.
Recommendation to Award to the Lowest Responsive Bidder

Dear Dr. Puglisi,

The Rio School District received 1 bid for RSD Project #21-03L Modular Classroom Building Electrical Service RDV.
The following company submitted a bid in the order listed. This Project is tentatively scheduled to be completed by May 10, 2021.

CONTRACTOR	BASE BID	Add Alternate (Not accepted)	Total Bid
Taft Electric	\$209,900.00	n/a	\$209,900.00

It is our recommendation that the Superintendent of Schools, per authorization by the Board of Education at its March 17, 2021 board meeting, proceed with issuing a Notice of Award to Taft Electric.

Should you have any questions or require any additional information, please contact me at any time.

Respectfully,

KH 3/4/2021

Keith Henderson
Senior Project Manager, Balfour Beatty Construction

cc. Wael Saleh Rio S.D.
Dennis Kuykendall BBC
Jesus Meugerza Ibarra BBC

10.19



Agenda Item Details

Meeting	Mar 17, 2021 - RSD Regular Board Meeting
Category	10. Consent
Subject	10.19 Approval of Award of Bid from MM Mechanical, Inc. for Project #21-04L for the Plumbing Services in Modular Classroom Building at Rio Del Valle
Access	Public
Type	Action (Consent)
Fiscal Impact	Yes
Dollar Amount	20,960.00
Budgeted	Yes
Budget Source	Measure L Funds
Recommended Action	It is recommended that the Board Approve the Request to Award the bid for Modular Classroom Building Plumbing Services at Rio Del Valle to M/M Mechanical, Inc.

Public Content

Speaker:
Wael Saleh, Assistant Superintendent, Business Services

Rationale:

The Rio School District received bids for RSD Project #21-04L Modular Classroom Building Plumbing Service at RDV. The following companies submitted bids in the order listed. This Project is tentatively scheduled to be completed by May 10, 2021.

CONTRACTOR	BASE BID	Add Alternate (Not accepted)	Total Bid
Precision Plumbing	\$34,363.00	n/a	\$34,363.00
MM Mechanical	\$20,960.00	n/a	\$20,960.00

It is our recommendation that the Superintendent of Schools, per authorization by the Board of Education at its March 17, 2021 board meeting, proceed with issuing a Notice of Award to MM Mechanical.

[21-04L MM Bid 3 2 2021 \(1\).pdf \(3,712 KB\)](#)

[21-04L Precision Bid 3 1 2021 \(1\).pdf \(4,383 KB\)](#)

[21-04L MM Recommendation to award 3 2 2021 \(1\) \(2\).pdf \(116 KB\)](#)

SECTION 00210

BID FORM
(CUPCAA PROJECTS UP TO \$200K)

TO: RIO SCHOOL DISTRICT, a political subdivision of the State of California ("District"), acting by and through its Board of Trustees ("Board"), 1800 Solar Dr. 3rd Floor, Oxnard, CA 93030.

FROM: mm mechanical Inc.
(Name of Bidder as listed on License)
Carpinteria, CA 93013
(Address)
(City, State, Zip Code)
Steven Vior, President
(Telephone) (FAX)
(Name(s) of Bidder's Authorized Representative(s) & Title)

1. Bid.

1.1 Bid Amount. Pursuant to and in compliance with the Notice to Contractors Calling for Bids, the Instructions for Bidders and the other documents relating thereto, the undersigned bidder having reviewed the Instructions for Bidders and all other Contract Documents¹ and upon compliance with all requirements therein with reference to the submittal of this bid, hereby proposes and agrees to perform the Contract including, without limitation, all of its component parts; to perform everything required to be performed; to provide and furnish any and all of the labor, materials, tools, equipment, applicable taxes, and services necessary to perform the Contract and complete in a workmanlike manner all of the Work required for the CUPCAA Project described as: **Modular Classroom Building Plumbing Service RDV, RSD Project # 21-04L** in accordance with the Contract Documents for the sum of:

"Total" Base Bid: Modular Classroom Building Plumbing Service RDV, RSD Project #21-04L

Twenty thousand nine hundred & sixty Dollars (\$ 20,900-)
(Amount in Words) (In Numbers)

The undersigned bidder agrees to achieve Final Completion of the Work within the Contract Time set forth in the Contract Documents.

¹ Capitalized terms used herein shall have the same meanings as those set forth in the General Conditions, Section 700, unless otherwise defined herein.

1.2 Alternate Bid Items Proposal. Bidders must provide a proposal price for each additive or deductive alternate bid item set forth herein; failure to do so will result in rejection of the bid proposal for non-responsiveness. After the public opening and reading of the bids, the District will in its sole and exclusive discretion select all, some or none of the additive or deductive alternate bid items for inclusion in the Contract awarded hereunder. The foregoing notwithstanding, if the District elects to include some, but not all of the alternate bid items in the Contract to be awarded hereunder, the selection of such alternate bid items will be by priority, as follows:

Alternates are listed from the highest to lowest priority based on their numerical orders.

Add/Alternate Bid No. 1

NONE Dollars (\$)
(Amount in Words) (In Numbers)

1.3 Acknowledgment of Bid Addenda. In submitting this bid, the undersigned bidder acknowledges receipt of all bid addenda issued by or on behalf of the District, as set forth below. The bidder confirms that this bid incorporates and is inclusive of, all items or other matters contained in bid addenda.

Addenda No. 8, dated through No. , dated , received, acknowledged and incorporated into this bid.

1.4 Alternate Bid Items. The bidder's price proposal(s) for alternate bid items is/are set forth in the form of alternate bid item proposal included herewith. The bidder acknowledges that, in accordance with the Instruction for Bidders, the Contract for the Work may be awarded in the District's sole discretion with or without some, all or none of the alternate bid items being incorporated into the scope of the Contract awarded. The bidder further acknowledges that the District's selection of alternate bid items, if any, for inclusion in the Contract awarded will be in accordance with the Instructions for Bidders.

2. Rejection of Bid; Holding Open of Bid. It is understood that the District reserves the right to reject this bid and that this bid shall remain open and not be withdrawn for the period of time specified in the Call for Bids, except as provided by law.

3. Documents Comprising Bid. The undersigned bidder has submitted as its bid the following:

1. 00210 Bid Form
2. 00215 Designation of Subcontractors
3. 00218 Contractors Registration Certification (DIR)
4. 00220 Non-Collusion Affidavit
5. 00222 Certification of Prevailing Wage
6. 00230 Contractor's Statement of Experience
7. 00240 Acknowledgment of Bidding Practices Regarding Indemnity

The bidder acknowledges that if this bid is not fully in compliance with applicable requirements set forth in the Call for Bids, the Instructions for Bidders and in each of the foregoing documents, the bid may be rejected as non-responsive.

4. **Award of Contract.** It is understood and agreed that if written notice of the acceptance of this bid and award of the Contract thereon is mailed, telegraphed or delivered by the District to the undersigned after the opening of bids and within the time this bid is required to remain open or at any time thereafter before this bid is withdrawn, the undersigned will execute and deliver to the District the Agreement in the form attached hereto in accordance with the Bid as accepted within ten (10) calendar days after notification of acceptance and award. Concurrently with delivery of the executed Agreement to the District, the bidder awarded the Contract shall deliver to the District: (a) certificates of insurance evidencing all insurance coverage required under the Contract Documents; (b) the performance bond; (c) the labor and material payment bond; (d) the Certificate of Workers' Compensation Insurance; and (e) the drug-free workplace certificate. The Work under the Contract Documents shall be commenced by the undersigned bidder, if awarded the Contract, on the date stated in the District's Notice to Proceed issued pursuant to the Contract Documents and completion of the Work shall be achieved within the Contract Time specified in the Contract Documents.
5. **Notices.** All notices or other correspondence shall be addressed to the District and the bidder at their respective addresses set forth herein. Notices shall be effective only if in writing and in conformity with the requirements for service of notices set forth in the Contract Documents.
6. **Contractor's License.** The undersigned Bidder is currently and duly licensed in accordance with the California Contractors License Law, California Business & Professions Code §§ 7000, *et seq.*, under the following:

License Number: 774231
Class C4 Expiration date 01-31-22 Class _____ Expiration date _____
Class C36 Expiration date 01-31-22 Class _____ Expiration date _____

By executing this bid, the bidder hereby certifies that: (a) it is duly licensed, in the necessary class(es), for performing the Work of the Contract Documents; (b) that such license shall be in full force and effect throughout the duration of the performance of the Work under the Contract Documents; and (c) that all Subcontractors providing or performing any portion of the Work of the Contract Documents shall be so similarly and appropriately licensed to perform or provide such portion of the Work.

7. **Designation of Subcontractors.** In compliance with the Subletting and Subcontracting Fair Practices Act (California Public Contract Code §§ 4100, *et seq.*) and amendments thereof, each bidder shall set forth in the Subcontractors List: (a) the name and location/address of the place of business of each Subcontractor who will perform work or labor or render services to the bidder in or about the construction of the Work to be performed under the Contract Documents in an amount in excess of one-half of one percent (0.005%) of the bidder's bid; and (b) the portion of the Work which will be performed by each listed Subcontractor. The bidder shall list only one Subcontractor for each portion of

the Work as is defined by the bidder in its bid. If a bidder fails to list a Subcontractor or if the bidder specifies more than one Subcontractor for the same portion of Work to be performed under the Contract Documents valued in excess of one-half of one percent (0.005%) of the bidder's bid amount, the bidder shall be deemed to have agreed that it is "fully qualified" to perform that portion of the Work itself and that it shall perform that portion of the Work.

(In addition, refer to Specification Section 00100 Instruction to Bidders, Section 21 Subcontractors, Sub Section 21.1 Designation of Subcontractors; Subcontractors list of the contract documents.)

8. **Confirmation of Figures.** By submitting this bid, the bidder confirms that it has checked all of the above figures and understands that neither the District nor any of its agents, employees or representatives shall be responsible for any errors or omissions on the part of the undersigned bidder in preparing and submitting this bid.

9. **Acknowledgment and Confirmation.** The undersigned bidder acknowledges its receipt, review and understanding of the Drawings, the Specifications and other Contract Documents pertaining to the proposed Work. The undersigned bidder certifies that the Contract Documents are, in its opinion, adequate, feasible and complete for providing, performing and constructing the Work in a sound and suitable manner for the use specified and intended by the Contract Documents. The undersigned bidder certifies that it has, or as available, all necessary equipment, personnel, materials, facilities and technical and financial ability to complete the Work for the amount bid herein within the Contract Time and in accordance with the Contract Documents.

(Corporate Seal)



Signature of Bidder's Authorized Representative

Steven Vior

Typed or Printed Name

President

Title

E-mail Address of Bidder's Authorized Representative

Department of Industrial Relations Registration Number

3/2/21

Date

**SECTION 00218
CERTIFICATION OF CONTRACTOR AND
SUBCONTRACTOR DIVISION OF INDUSTRIAL RELATIONS REGISTRATION
(DIR)
(CUPCCAA PROJECTS UP TO \$200K)**

Pursuant to Public Contract Code Section 1725.5, a contractor or subcontractor must be registered with the Department of Industrial relations in order to bid on, to be listed in a bid proposal or to engage in the performance of any defined public work contract.

I Steven Visor, President certify that
(Name) (Title)
Mm Mechanical Inc. is currently registered as a contractor with the Department of Industrial
(Contractor Name)

Relations (DIR):

Contractor's DIR Registration Number _____

Expiration date June 30, 2021

Contract further acknowledges:

1. Contractor shall maintain DIR registered status for the duration of the project without a gap in registration.
2. Contractor shall note in its invitation to bid the DIR's registration requirement for all subcontractors and their subcontractors.
3. Contractor shall ensure that all subcontractors are registered at time of bid opening and maintain registered status for the duration of the project.
4. Contractor is to furnish DIR Registration Number for all subcontractors on the project within 24 hours of the bid opening.
5. Contractor shall substitute any subcontractor with a DIR registered contractor if listed subcontractor is unable to perform the work.

Failure to comply with any of the above may result in a determination of non-responsiveness.

I declare under penalty of perjury under California law that the foregoing is true and correct.



Signature

3/2/21

Date

**(CUPCCAA PROJECT) SECTION 00218
CERTIFICATION OF CONTRACTOR AND SUBCONTRACTOR DIVISION OF INDUSTRIAL RELATIONS
REGISTRATION**

Modular Classroom Building Plumbing Service RDV
RSD Project # 21-04L

SECTION 00220

NON-COLLUSION AFFIDAVIT
(CUPCCAA PROJECTS UP TO \$200K)
(Must be submitted with bid)

STATE OF CALIFORNIA
COUNTY OF Santa Barbara

I, Steven Vior, being first duly sworn, deposes and
(Typed or Printed Name).
says that I am the President of mm Mechanical Inc.
(Title) (Company Name)

the party submitting the foregoing bid proposal (the "Bidder"). In connection with the foregoing bid proposal ("Bid Proposal"), the undersigned declares, states and certifies that:

1. The Bid Proposal is not made in the interest of, or on behalf of, any undisclosed person, partnership, company, association, organization or corporation.
2. The Bid Proposal is genuine and not collusive or sham.
3. The Bidder has not directly or indirectly induced or solicited any other bidder to put in a false or sham bid, and has not directly or indirectly colluded, conspired, connived, or agreed with any other bidder or anyone else to put in sham bid, or to refrain from bidding.
4. The Bidder has not in any manner, directly or indirectly, sought by agreement, communication, or conference with anyone to fix the bid price, or that of any other bidder, or to fix any overhead, profit or cost element of the bid price or that of any other bidder, or to secure any advantage against the public body awarding the contract or of anyone interested in the proposed contract.
5. All statements contained in the Bid Proposal and related documents are true.
6. The Bidder has not, directly or indirectly, submitted the bid price or any breakdown thereof, or the contents thereof, or divulged information or data relative thereto, or paid, and will not pay, any fee to any person, corporation, partnership, company, association, organization, bid depository, or to any member or agent thereof to effectuate a collusive or sham bid.

Executed this 2 day of March, 2021 at Carpinteria, SB, CA
(City, County and State)

I declare under penalty of perjury under the laws of the State of California that the foregoing is true and correct.

[Signature]
(Signature)

[Address]
(Address)

Steven Vior
(Name Printed or Typed)

Carpinteria, CA 93013
(City, State and Zip)

[Area Code and Telephone Number]
(Area Code and Telephone Number)

[Email] Inc.
(Email)

SECTION 00222

**CERTIFICATION OF PREVAILING WAGE AND
RELATED LABOR REQUIREMENTS
(CUPCCAA PROJECTS UP TO \$200K)**

PROJECT/CONTRACT NO.: 21-04L between mm mechanical Inc.
("District") and Rio School District ("Contractor"
or "Bidder") ("Contract" or "Project").

I hereby certify that I will conform to the State of California Public Works Contract requirements regarding prevailing wages, benefits, on-site audits with 48-hours notice, payroll records, and apprentice and trainee employment requirements, for all Work on the above Project including, without limitation, labor compliance monitoring and enforcement by the Department of Industrial Relations.

Date: 3/2/21
Proper Name of Contractor: mm mechanical Inc.
Contractor Signature: 
Print Name: Steven Vior
Title: President

SECTION 00240

ACKNOWLEDGMENT OF BIDDING
PRACTICES REGARDING INDEMNITY

(CUPCAA PROJECTS UP TO \$200K)

TO: Rio School District, 1800 Solar Dr. 3rd Floor, Oxnard, California 93030

RE: Project Number 21-04L

Project Name Modular Classroom Bldg. Plumbing

Please be advised that with respect to the above-referenced Project, the undersigned Contractor, on behalf of itself and all subcontractors, hereby waives the benefits and protection of Labor Code Section 3864, which provides:

If an action as provided in this chapter prosecuted by the employee, the employer, or both jointly against the third person results in judgment against such third person, or settlement by such third person, the employer shall have no liability to reimburse or hold such third person harmless on such judgment or settlement in absence of a written agreement so to do executed prior to the injury.

This agreement has been signed by an authorized representative of the contracting party and shall be binding upon its successors and assigns. The undersigned further agrees to promptly notify the District of any changes of ownership of the contracting party or any subcontractor while this Agreement is in force.

Mm mechanical Inc. 
Contracting Party

Steven Vior, President
Name of Agent/Title

3/2/21
Date

END OF SECTION

SECTION 00210

BID FORM
(CUPCCAA PROJECTS UP TO \$200K)

TO: RIO SCHOOL DISTRICT, a political subdivision of the State of California ("District"), acting by and through its Board of Trustees ("Board"), 1800 Solar Dr. 3rd Floor, Oxnard, CA 93030.

FROM: John S. Bascom Inc. dba Precision Plumbing Mechanical
(Name of Bidder as listed on License)

(Address)

(City, State, Zip Code)

(805) 329-4148

(Telephone)

(FAX)

Daniel Bascom / Project Manager

(Name(s) of Bidder's Authorized Representative(s) & Title)

1. Bid.

1.1 Bid Amount. Pursuant to and in compliance with the Notice to Contractors Calling for Bids, the Instructions for Bidders and the other documents relating thereto, the undersigned bidder having reviewed the Instructions for Bidders and all other Contract Documents¹ and upon compliance with all requirements therein with reference to the submittal of this bid, hereby proposes and agrees to perform the Contract including, without limitation, all of its component parts; to perform everything required to be performed; to provide and furnish any and all of the labor, materials, tools, equipment, applicable taxes, and services necessary to perform the Contract and complete in a workmanlike manner all of the Work required for the CUPCCAA Project described as: **Modular Classroom Building Plumbing Service RDV. RSD Project # 21-04L** in accordance with the Contract Documents for the sum of:

"Total" Base Bid: Modular Classroom Building Plumbing Service RDV, RSD Project #21-04L

Thirty Four Thousand Three Hundred Sixty Three

(Amount in Words)

Dollars (\$ 34,363.00)

(In Numbers)

The undersigned bidder agrees to achieve Final Completion of the Work within the Contract Time set forth in the Contract Documents.

¹ Capitalized terms used herein shall have the same meanings as those set forth in the General Conditions, Section 700, unless otherwise defined herein.

1.2 Alternate Bid Items Proposal. Bidders must provide a proposal price for each additive or deductive alternate bid item set forth herein; failure to do so will result in rejection of the bid proposal for non-responsiveness. After the public opening and reading of the bids, the District will in its sole and exclusive discretion select all, some or none of the additive or deductive alternate bid items for inclusion in the Contract awarded hereunder. The foregoing notwithstanding, if the District elects to include some, but not all of the alternate bid items in the Contract to be awarded hereunder, the selection of such alternate bid items will be by priority, as follows:

Alternates are listed from the highest to lowest priority based on their numerical orders.

Add/Alternate Bid No. 1

NONE Dollars (\$)
(Amount in Words) (In Numbers)

1.3 Acknowledgment of Bid Addenda. In submitting this bid, the undersigned bidder acknowledges receipt of all bid addenda issued by or on behalf of the District, as set forth below. The bidder confirms that this bid incorporates and is inclusive of, all items or other matters contained in bid addenda.

Addenda No. 0 , dated N/A through No. 0 , dated N/A , received, acknowledged and incorporated into this bid.

1.4 Alternate Bid Items. The bidder's price proposal(s) for alternate bid items is/are set forth in the form of alternate bid item proposal included herewith. The bidder acknowledges that, in accordance with the Instruction for Bidders, the Contract for the Work may be awarded in the District's sole discretion with or without some, all or none of the alternate bid items being incorporated into the scope of the Contract awarded. The bidder further acknowledges that the District's selection of alternate bid items, if any, for inclusion in the Contract awarded will be in accordance with the Instructions for Bidders.

2. Rejection of Bid; Holding Open of Bid. It is understood that the District reserves the right to reject this bid and that this bid shall remain open and not be withdrawn for the period of time specified in the Call for Bids, except as provided by law.

3. Documents Comprising Bid. The undersigned bidder has submitted as its bid the following:

1. 00210 Bid Form
2. 00215 Designation of Subcontractors
3. 00218 Contractors Registration Certification (DIR)
4. 00220 Non-Collusion Affidavit
5. 00222 Certification of Prevailing Wage
6. 00230 Contractor's Statement of Experience
7. 00240 Acknowledgment of Bidding Practices Regarding Indemnity

The bidder acknowledges that if this bid is not fully in compliance with applicable requirements set forth in the Call for Bids, the Instructions for Bidders and in each of the foregoing documents, the bid may be rejected as non-responsive.

4. **Award of Contract.** It is understood and agreed that if written notice of the acceptance of this bid and award of the Contract thereon is mailed, telegraphed or delivered by the District to the undersigned after the opening of bids and within the time this bid is required to remain open or at any time thereafter before this bid is withdrawn, the undersigned will execute and deliver to the District the Agreement in the form attached hereto in accordance with the Bid as accepted within ten (10) calendar days after notification of acceptance and award. Concurrently with delivery of the executed Agreement to the District, the bidder awarded the Contract shall deliver to the District: (a) certificates of insurance evidencing all insurance coverage required under the Contract Documents; (b) the performance bond; (c) the labor and material payment bond; (d) the Certificate of Workers' Compensation Insurance; and (e) the drug-free workplace certificate. The Work under the Contract Documents shall be commenced by the undersigned bidder, if awarded the Contract, on the date stated in the District's Notice to Proceed issued pursuant to the Contract Documents and completion of the Work shall be achieved within the Contract Time specified in the Contract Documents.
5. **Notices.** All notices or other correspondence shall be addressed to the District and the bidder at their respective addresses set forth herein. Notices shall be effective only if in writing and in conformity with the requirements for service of notices set forth in the Contract Documents.
6. **Contractor's License.** The undersigned Bidder is currently and duly licensed in accordance with the California Contractors License Law, California Business & Professions Code §§ 7000, *et seq.*, under the following:

License Number: 533836

Class C4 Expiration date 06-30-2022

Class _____ Expiration date _____

Class C36 Expiration date 06-30-2022

Class _____ Expiration date _____

By executing this bid, the bidder hereby certifies that: (a) it is duly licensed, in the necessary class(es), for performing the Work of the Contract Documents; (b) that such license shall be in full force and effect throughout the duration of the performance of the Work under the Contract Documents; and (c) that all Subcontractors providing or performing any portion of the Work of the Contract Documents shall be so similarly and appropriately licensed to perform or provide such portion of the Work.

7. **Designation of Subcontractors.** In compliance with the Subletting and Subcontracting Fair Practices Act (California Public Contract Code §§ 4100, *et seq.*) and amendments thereof, each bidder shall set forth in the Subcontractors List: (a) the name and location/address of the place of business of each Subcontractor who will perform work or labor or render services to the bidder in or about the construction of the Work to be performed under the Contract Documents in an amount in excess of one-half of one percent (0.005%) of the bidder's bid; and (b) the portion of the Work which will be performed by each listed Subcontractor. The bidder shall list only one Subcontractor for each portion of

the Work as is defined by the bidder in its bid. If a bidder fails to list a Subcontractor or if the bidder specifies more than one Subcontractor for the same portion of Work to be performed under the Contract Documents valued in excess of one-half of one percent (0.005%) of the bidder's bid amount, the bidder shall be deemed to have agreed that it is "fully qualified" to perform that portion of the Work itself and that it shall perform that portion of the Work.

(In addition, refer to Specification Section 00100 Instruction to Bidders, Section 21 Subcontractors, Sub Section 21.1 Designation of Subcontractors; Subcontractors list of the contract documents.)

8. **Confirmation of Figures.** By submitting this bid, the bidder confirms that it has checked all of the above figures and understands that neither the District nor any of its agents, employees or representatives shall be responsible for any errors or omissions on the part of the undersigned bidder in preparing and submitting this bid.
9. **Acknowledgment and Confirmation.** The undersigned bidder acknowledges its receipt, review and understanding of the Drawings, the Specifications and other Contract Documents pertaining to the proposed Work. The undersigned bidder certifies that the Contract Documents are, in its opinion, adequate, feasible and complete for providing, performing and constructing the Work in a sound and suitable manner for the use specified and intended by the Contract Documents. The undersigned bidder certifies that it has, or as available, all necessary equipment, personnel, materials, facilities and technical and financial ability to complete the Work for the amount bid herein within the Contract Time and in accordance with the Contract Documents.

(Corporate Seal)



Signature of Bidder's Authorized Representative

Daniel Bascom

Typed or Printed Name

Project Manager

Title

E-mail Address of Bidder's Authorized Representative

Department of Industrial Relations Registration Number

03-02-2021

Date

END OF SECTION

SECTION 00215

**DESIGNATION OF SUBCONTRACTORS
(CUPCCAA PROJECTS UP TO \$200K)**

(Must be submitted with bid)

1. In compliance with the Subletting and Subcontracting Fair Practices Act (Government Code Section 4100, *et seq.*) and any amendments thereof, each bidder shall set forth below:
 - a. The name and the location of the place of business of each services to the prime contractor in or about the construction of the work or improvement to be performed under this contract in an amount in excess of one-half of one percent (0.005%) of the prime contractor's total bid, and
 - b. The portion of the work which will be done by each subcontractor under this act. The prime contractor shall list only one subcontractor for each portion as is defined by the prime contractor in this bid.
2. If a prime contractor fails to specify a subcontractor or if a prime contractor specifies more than one subcontractor for the same portion of work to be performed under the contract in excess of one-half of one percent (0.005%) of the prime contractor's total bid, the prime contractor shall be deemed to have agreed to be fully qualified to perform that portion of work, and that it shall be performed by the contractor.
3. No prime contractor whose bid is accepted shall:
 - a. Substitute any subcontractor without written approval by the District,
 - b. Permit any subcontract to be voluntarily assigned or transferred or allow it to be performed by anyone other than the original subcontractor listed in the original bid,
 - c. Sublet or subcontract any portion of the work in excess of one-half of one percent of the prime contractor's total bid as was originally bid and did not designate a subcontractor, except as authorized in the Subletting and Subcontracting Fair Practices Act.

Subletting or subcontracting of any portion of the work in excess of one-half of one percent (0.005%) of the prime contractor's total bid as to which subcontractor was designated in the original bid shall only be permitted to cases of public emergency or necessity, and then only after a finding reduced to writing as public record of the authority awarding this contract, setting forth the facts constituting the emergency or necessity.

NOTE: If alternate bids are called for and bidder intends to use different or additional subcontractors on the alternates, a separate list of subcontractors must be provided for each such alternate.

4. **MANDATORY REGISTRATION WITH THE DEPARTMENT OF INDUSTRIAL RELATIONS** - Senate Bill 854 requires ALL contractors and subcontractors submitting bids on public works projects to be registered with the Department of Industrial Relations ("DIR") for purposes of labor compliance. All contractors and subcontractors must submit proof of valid, accurate, and current DIR registration with their bid. Rio School District will not accept bids from any contractors or subcontractors who are not registered with the DIR at the time the bid is submitted. Any contractors or subcontractors submitting a bid without being registered with the DIR at the time of bid will have their bid rejected as being non responsive. All contractors must affirmatively acknowledge their obligation not to hire subcontractors who lack an accurate, valid DIR registration number.

END OF SECTION

**SECTION 00218
CERTIFICATION OF CONTRACTOR AND
SUBCONTRACTOR DIVISION OF INDUSTRIAL RELATIONS REGISTRATION
(DIR)
(CUPCAA PROJECTS UP TO \$200K)**

Pursuant to Public Contract Code Section 1725.5, a contractor or subcontractor must be registered with the Department of Industrial relations in order to bid on, to be listed in a bid proposal or to engage in the performance of any defined public work contract.

I Daniel Bascom _____, Project Manager _____ certify that
(Name) (Title)

John S. Bascom Inc. dba Precision Plumbing Mechanical is currently registered as a contractor with the Department of Industrial
(Contractor Name)

Relations (DIR):

Contractor's DIR Registration Number 1000004502

Expiration date June 30, 20 22

Contract further acknowledges:

1. Contractor shall maintain DIR registered status for the duration of the project without a gap in registration.
2. Contractor shall note in its invitation to bid the DIR's registration requirement for all subcontractors and their subcontractors.
3. Contractor shall ensure that all subcontractors are registered at time of bid opening and maintain registered status for the duration of the project.
4. Contractor is to furnish DIR Registration Number for all subcontractors on the project within 24 hours of the bid opening.
5. Contractor shall substitute any subcontractor with a DIR registered contractor if listed subcontractor is unable to perform the work.

Failure to comply with any of the above may result in a determination of non-responsiveness.

I declare under penalty of perjury under California law that the foregoing is true and correct.



Signature

03-02-21

Date

(CUPCAA PROJECT) SECTION 00218
CERTIFICATION OF CONTRACTOR AND SUBCONTRACTOR DIVISION OF INDUSTRIAL RELATIONS
REGISTRATION
Modular Classroom Building Plumbing Service RDV
RSD Project # 21-04L

SECTION 00220

NON-COLLUSION AFFIDAVIT
(CUPCCAA PROJECTS UP TO \$200K)
(Must be submitted with bid)

STATE OF CALIFORNIA
COUNTY OF Ventura

I, Daniel Bascom, being first duly sworn, deposes and
(Typed or Printed Name)
says that I am the Project Manager of John S. Bascom Inc. dba Precision Plumbing Mechanical
(Title) *(Company Name)*
the party submitting the foregoing bid proposal (the "Bidder"). In connection with the foregoing
bid proposal ("Bid Proposal"), the undersigned declares, states and certifies that:

1. The Bid Proposal is not made in the interest of, or on behalf of, any undisclosed person, partnership, company, association, organization or corporation.
2. The Bid Proposal is genuine and not collusive or sham.
3. The Bidder has not directly or indirectly induced or solicited any other bidder to put in a false or sham bid, and has not directly or indirectly colluded, conspired, connived, or agreed with any other bidder or anyone else to put in sham bid, or to refrain from bidding.
4. The Bidder has not in any manner, directly or indirectly, sought by agreement, communication, or conference with anyone to fix the bid price, or that of any other bidder, or to fix any overhead, profit or cost element of the bid price or that of any other bidder, or to secure any advantage against the public body awarding the contract or of anyone interested in the proposed contract.
5. All statements contained in the Bid Proposal and related documents are true.
6. The Bidder has not, directly or indirectly, submitted the bid price or any breakdown thereof, or the contents thereof, or divulged information or data relative thereto, or paid, and will not pay, any fee to any person, corporation, partnership, company, association, organization, bid depository, or to any member or agent thereof to effectuate a collusive or sham bid.

Executed this 02 day of March, 2021 at Moorpark, Ventura, California
(City, County and State)

I declare under penalty of perjury under the laws of the State of California that the foregoing is true and correct.

(Signature)

(Address)

Daniel Bascom
(Name Printed or Typed)

(City, State and Zip)

(Area Code and Telephone Number)

(Email)

END OF SECTION

(This page intentionally left blank)

SECTION 00222

**CERTIFICATION OF PREVAILING WAGE AND
RELATED LABOR REQUIREMENTS
(CUPCCAA PROJECTS UP TO \$200K)**

PROJECT/CONTRACT NO.: 21-04L between Rio School District
("District") and John S. Bascom Inc. dba Precision Plumbing Mechanical ("Contractor"
or "Bidder") ("Contract" or "Project").

I hereby certify that I will conform to the State of California Public Works Contract requirements regarding prevailing wages, benefits, on-site audits with 48-hours notice, payroll records, and apprentice and trainee employment requirements, for all Work on the above Project including, without limitation, labor compliance monitoring and enforcement by the Department of Industrial Relations.

Date: March 02, 2021

Proper Name of Contractor: John S. Bascom Inc. dba Precision Plumbing Mechanical

Contractor Signature: 

Print Name: Daniel Bascom

Title: Project Manager

(CUPCCAA PROJECT) Section 00222
Certification of Prevailing Wage and Related Labor Requirements
Modular Classroom Building Plumbing Service RDV
RSD Project #21-04L

SECTION 00240

**ACKNOWLEDGMENT OF BIDDING
PRACTICES REGARDING INDEMNITY**

(CUPCCAA PROJECTS UP TO \$200K)

TO: **Rio School District, 1800 Solar Dr. 3rd Floor, Oxnard, California 93030**

RE: Project Number 21-04L

Project Name Modular Classroom Building Plumbing Service RDV

Please be advised that with respect to the above-referenced Project, the undersigned Contractor, on behalf of itself and all subcontractors, hereby waives the benefits and protection of Labor Code Section 3864, which provides:

If an action as provided in this chapter prosecuted by the employee, the employer, or both jointly against the third person results in judgment against such third person, or settlement by such third person, the employer shall have no liability to reimburse or hold such third person harmless on such judgment or settlement in absence of a written agreement so to do executed prior to the injury.

This agreement has been signed by an authorized representative of the contracting party and shall be binding upon its successors and assigns. The undersigned further agrees to promptly notify the District of any changes of ownership of the contracting party or any subcontractor while this Agreement is in force.



Contracting Party

Daniel Bascom / Project Manager

Name of Agent/Title

March 02, 2021

Date

END OF SECTION

(CUPCCAA PROJECT) Acknowledgment of Bidding Practices Regarding Indemnity – 00240

Modular Classroom Building Plumbing Service RDV

RSD Project # 21-04L

Page 1 of 1

Rio School District
1800 Solar, 3rd Floor
Oxnard, CA 93036
Attn: Dr. John Puglisi, Superintendent

March 2, 2021

Subject: Request for Board Approval to Award Project

Re: RSD Project #21-04L Modular Classroom Building Plumbing Service RDV
Recommendation to Award to the Lowest Responsive Bidder

Dear Dr. Puglisi,

The Rio School District received bids for RSD Project #21-04L Modular Classroom Building Plumbing Service RDV. The following company's submitted bids in the order listed. This Project is tentatively scheduled to be completed by May 10, 2021.

CONTRACTOR	BASE BID	Add Alternate (Not accepted)	Total Bid
Precision Plumbing	\$34,363.00	n/a	\$34,363.00
MM Mechanical	\$20,960.00	n/a	\$20,960.00

It is our recommendation that the Superintendent of Schools, per authorization by the Board of Education at its March 17, 2021 board meeting, proceed with issuing a Notice of Award to MM Mechanical.

Should you have any questions or require any additional information, please contact me at any time.

Respectfully,

KH 3/2/2021

Keith Henderson
Senior Project Manager, Balfour Beatty Construction

cc. Wael Saleh Rio S.D.
Dennis Kuykendall BBC
Jesus Meugerza Ibarra BBC

10.20



Agenda Item Details

Meeting	Mar 17, 2021 - RSD Regular Board Meeting
Category	10. Consent
Subject	10.20 Approval of Award of Bid to Custom Modular Services Corporation for Project #21-02L for the Modular Classroom Building Renovation at Rio Del Valle
Access	Public
Type	Action (Consent)
Fiscal Impact	Yes
Dollar Amount	197,620.80
Budgeted	Yes
Budget Source	Measure L Funds
Recommended Action	It is recommended that the Board Approve the Notice of Award to Custom Modular Services Corporation for Project #21-02L for the Modular Classroom Building Renovation at Rio Del Valle.

Public Content

Speaker:
Wael Saleh, Assistant Superintendent, Business Services

Rationale:
The Rio School District received one bid for RSD Project #21-02L for the Modular Classroom Building Renovation at Rio Del Valle. The bid was as follows:

The Rio School District received 1 bid for RSD Project #21-02L Modular Classroom Building Renovation RDV. The following company submitted a bid in the order listed. This Project is tentatively scheduled to be completed by May 10, 2021.

CONTRACTOR	BASE BID	Add Alternate (Not accepted)	Total Bid
Custom Modular	\$197,620.80	n/a	\$197,620.80

It is our recommendation that the Superintendent of Schools, per authorization by the Board of Education at its March 17, 2021 board meeting, proceed with issuing a Notice of Award to Custom Modular Services Corporation.

SECTION 00210

BID FORM
(CUPCAA PROJECTS UP TO \$200K)

TO: RIO SCHOOL DISTRICT, a political subdivision of the State of California ("District"), acting by and through its Board of Trustees ("Board"), 1800 Solar Dr. 3rd Floor, Oxnard, CA 93030.

FROM: Custom Modular Services Corporation
(Name of Bidder as listed on License)

(Address)
Huntington Beach, CA 92646
(City, State, Zip Code)

(Telephone) *(FAX)*
Edward Mouawad, President
(Name(s) of Bidder's Authorized Representative(s) & Title)

1. Bid.

1.1 Bid Amount. Pursuant to and in compliance with the Notice to Contractors Calling for Bids, the Instructions for Bidders and the other documents relating thereto, the undersigned bidder having reviewed the Instructions for Bidders and all other Contract Documents¹ and upon compliance with all requirements therein with reference to the submittal of this bid, hereby proposes and agrees to perform the Contract including, without limitation, all of its component parts; to perform everything required to be performed; to provide and furnish any and all of the labor, materials, tools, equipment, applicable taxes, and services necessary to perform the Contract and complete in a workmanlike manner all of the Work required for the CUPCAA Project described as: Modular Classroom Building Renovation RDV. RSD Project # 21-02L in accordance with the Contract Documents for the sum of:

"Total" Base Bid: Modular Classroom Building Renovation RDV, RSD Project #21-02L

One hundred ninety-seven thousand, six hundred twenty dollars & eighty cents Dollars (\$ 197,620.80)
(Amount in Words) *(In Numbers)*

The undersigned bidder agrees to achieve Final Completion of the Work within the Contract Time set forth in the Contract Documents. *pending material availability*



¹ Capitalized terms used herein shall have the same meanings as those set forth in the General Conditions, Section 700, unless otherwise defined herein.

1.2 Alternate Bid Items Proposal. Bidders must provide a proposal price for each additive or deductive alternate bid item set forth herein; failure to do so will result in rejection of the bid proposal for non-responsiveness. After the public opening and reading of the bids, the District will in its sole and exclusive discretion select all, some or none of the additive or deductive alternate bid items for inclusion in the Contract awarded hereunder. The foregoing notwithstanding, if the District elects to include some, but not all of the alternate bid items in the Contract to be awarded hereunder, the selection of such alternate bid items will be by priority, as follows:

Alternates are listed from the highest to lowest priority based on their numerical orders.

Add/Alternate Bid No. 1

NONE Dollars (\$)
(Amount in Words) (In Numbers)

1.3 Acknowledgment of Bid Addenda. In submitting this bid, the undersigned bidder acknowledges receipt of all bid addenda issued by or on behalf of the District, as set forth below. The bidder confirms that this bid incorporates and is inclusive of, all items or other matters contained in bid addenda.

Addenda No. , dated through No. , dated , received, acknowledged and incorporated into this bid.

1.4 Alternate Bid Items. The bidder's price proposal(s) for alternate bid items is/are set forth in the form of alternate bid item proposal included herewith. The bidder acknowledges that, in accordance with the Instruction for Bidders, the Contract for the Work may be awarded in the District's sole discretion with or without some, all or none of the alternate bid items being incorporated into the scope of the Contract awarded. The bidder further acknowledges that the District's selection of alternate bid items, if any, for inclusion in the Contract awarded will be in accordance with the Instructions for Bidders.

2. Rejection of Bid; Holding Open of Bid. It is understood that the District reserves the right to reject this bid and that this bid shall remain open and not be withdrawn for the period of time specified in the Call for Bids, except as provided by law.

3. Documents Comprising Bid. The undersigned bidder has submitted as its bid the following:

1. 00210 Bid Form
2. 00215 Designation of Subcontractors
3. 00218 Contractors Registration Certification (DIR)
4. 00220 Non-Collusion Affidavit
5. 00222 Certification of Prevailing Wage
6. 00230 Contractor's Statement of Experience
7. 00240 Acknowledgment of Bidding Practices Regarding Indemnity

The bidder acknowledges that if this bid is not fully in compliance with applicable requirements set forth in the Call for Bids, the Instructions for Bidders and in each of the foregoing documents, the bid may be rejected as non-responsive.

4. **Award of Contract.** It is understood and agreed that if written notice of the acceptance of this bid and award of the Contract thereon is mailed, telegraphed or delivered by the District to the undersigned after the opening of bids and within the time this bid is required to remain open or at any time thereafter before this bid is withdrawn, the undersigned will execute and deliver to the District the Agreement in the form attached hereto in accordance with the Bid as accepted within ten (10) calendar days after notification of acceptance and award. Concurrently with delivery of the executed Agreement to the District, the bidder awarded the Contract shall deliver to the District: (a) certificates of insurance evidencing all insurance coverage required under the Contract Documents; (b) the performance bond; (c) the labor and material payment bond; (d) the Certificate of Workers' Compensation Insurance; and (e) the drug-free workplace certificate. The Work under the Contract Documents shall be commenced by the undersigned bidder, if awarded the Contract, on the date stated in the District's Notice to Proceed issued pursuant to the Contract Documents and completion of the Work shall be achieved within the Contract Time specified in the Contract Documents.
5. **Notices.** All notices or other correspondence shall be addressed to the District and the bidder at their respective addresses set forth herein. Notices shall be effective only if in writing and in conformity with the requirements for service of notices set forth in the Contract Documents.
6. **Contractor's License.** The undersigned Bidder is currently and duly licensed in accordance with the California Contractors License Law, California Business & Professions Code §§ 7000, *et seq.*, under the following:

License Number: 570805
Class B Expiration date 12/31/21 Class _____ Expiration date _____
Class _____ Expiration date _____ Class _____ Expiration date _____

By executing this bid, the bidder hereby certifies that: (a) it is duly licensed, in the necessary class(es), for performing the Work of the Contract Documents; (b) that such license shall be in full force and effect throughout the duration of the performance of the Work under the Contract Documents; and (c) that all Subcontractors providing or performing any portion of the Work of the Contract Documents shall be so similarly and appropriately licensed to perform or provide such portion of the Work.

7. **Designation of Subcontractors.** In compliance with the Subletting and Subcontracting Fair Practices Act (California Public Contract Code §§ 4100, *et seq.*) and amendments thereof, each bidder shall set forth in the Subcontractors List: (a) the name and location/address of the place of business of each Subcontractor who will perform work or labor or render services to the bidder in or about the construction of the Work to be performed under the Contract Documents in an amount in excess of one-half of one percent (0.005%) of the bidder's bid; and (b) the portion of the Work which will be performed by each listed Subcontractor. The bidder shall list only one Subcontractor for each portion of

the Work as is defined by the bidder in its bid. If a bidder fails to list a Subcontractor or if the bidder specifies more than one Subcontractor for the same portion of Work to be performed under the Contract Documents valued in excess of one-half of one percent (0.005%) of the bidder's bid amount, the bidder shall be deemed to have agreed that it is "fully qualified" to perform that portion of the Work itself and that it shall perform that portion of the Work.

(In addition, refer to Specification Section 00100 Instruction to Bidders, Section 21 Subcontractors, Sub Section 21.1 Designation of Subcontractors; Subcontractors list of the contract documents.)

8. **Confirmation of Figures.** By submitting this bid, the bidder confirms that it has checked all of the above figures and understands that neither the District nor any of its agents, employees or representatives shall be responsible for any errors or omissions on the part of the undersigned bidder in preparing and submitting this bid.
9. **Acknowledgment and Confirmation.** The undersigned bidder acknowledges its receipt, review and understanding of the Drawings, the Specifications and other Contract Documents pertaining to the proposed Work. The undersigned bidder certifies that the Contract Documents are, in its opinion, adequate, feasible and complete for providing, performing and constructing the Work in a sound and suitable manner for the use specified and intended by the Contract Documents. The undersigned bidder certifies that it has, or as available, all necessary equipment, personnel, materials, facilities and technical and financial ability to complete the Work for the amount bid herein within the Contract Time and in accordance with the Contract Documents.



Signature of Bidder's Authorized Representative

Edward Mouawad

Typed or Printed Name
President

Title
_____ . com

E-mail Address of Bidder's Authorized Representative

Department of Industrial Relations Registration Number

3/1/21

Date

(Corporate Seal)

SECTION 00215

**DESIGNATION OF SUBCONTRACTORS
(CUPCCAA PROJECTS UP TO \$200K)**

(Must be submitted with bid)

1. In compliance with the Subletting and Subcontracting Fair Practices Act (Government Code Section 4100, *et seq.*) and any amendments thereof, each bidder shall set forth below:
 - a. The name and the location of the place of business of each services to the prime contractor in or about the construction of the work or improvement to be performed under this contract in an amount in excess of one-half of one percent (0.005%) of the prime contractor's total bid, and
 - b. The portion of the work which will be done by each subcontractor under this act. The prime contractor shall list only one subcontractor for each portion as is defined by the prime contractor in this bid.
2. If a prime contractor fails to specify a subcontractor or if a prime contractor specifies more than one subcontractor for the same portion of work to be performed under the contract in excess of one-half of one percent (0.005%) of the prime contractor's total bid, the prime contractor shall be deemed to have agreed to be fully qualified to perform that portion of work, and that it shall be performed by the contractor.
3. No prime contractor whose bid is accepted shall:
 - a. Substitute any subcontractor without written approval by the District,
 - b. Permit any subcontract to be voluntarily assigned or transferred or allow it to be performed by anyone other than the original subcontractor listed in the original bid,
 - c. Sublet or subcontract any portion of the work in excess of one-half of one percent of the prime contractor's total bid as was originally bid and did not designate a subcontractor, except as authorized in the Subletting and Subcontracting Fair Practices Act.

Subletting or subcontracting of any portion of the work in excess of one-half of one percent (0.005%) of the prime contractor's total bid as to which subcontractor was designated in the original bid shall only be permitted to cases of public emergency or necessity, and then only after a finding reduced to writing as public record of the authority awarding this contract, setting forth the facts constituting the emergency or necessity.

NOTE: If alternate bids are called for and bidder intends to use different or additional subcontractors on the alternates, a separate list of subcontractors must be provided for each such alternate.

4. **MANDATORY REGISTRATION WITH THE DEPARTMENT OF INDUSTRIAL RELATIONS - Senate Bill 854 requires ALL contractors and subcontractors submitting bids on public works projects to be registered with the Department of Industrial Relations ("DIR") for purposes of labor compliance. All contractors and subcontractors must submit proof of valid, accurate, and current DIR registration with their bid. Rio School District will not accept bids from any contractors or subcontractors who are not registered with the DIR at the time the bid is submitted. Any contractors or subcontractors submitting a bid without being registered with the DIR at the time of bid will have their bid rejected as being non responsive. All contractors must affirmatively acknowledge their obligation not to hire subcontractors who lack an accurate, valid DIR registration number.**

END OF SECTION

**SECTION 00218
CERTIFICATION OF CONTRACTOR AND
SUBCONTRACTOR DIVISION OF INDUSTRIAL RELATIONS REGISTRATION
(DIR)
(CUPCAA PROJECTS UP TO \$200K)**

Pursuant to Public Contract Code Section 1725.5, a contractor or subcontractor must be registered with the Department of Industrial relations in order to bid on, to be listed in a bid proposal or to engage in the performance of any defined public work contract.

I Edward Mouawad _____, President _____ certify that
(Name) (Title)

Custom Modular Services Corporation is currently registered as a contractor with the Department of Industrial
(Contractor Name)

Relations (DIR):

Contractors DIR Registration Number _____

Expiration date June 30, 2021

Contract further acknowledges:

1. Contractor shall maintain DIR registered status for the duration of the project without a gap in registration.
2. Contractor shall note in its invitation to bid the DIR's registration requirement for all subcontractors and their subcontractors.
3. Contractor shall ensure that all subcontractors are registered at time of bid opening and maintain registered status for the duration of the project.
4. Contractor is to furnish DIR Registration Number for all subcontractors on the project within 24 hours of the bid opening.
5. Contractor shall substitute any subcontractor with a DIR registered contractor if listed subcontractor is unable to perform the work.

Failure to comply with any of the above may result in a determination of non-responsiveness.

I declare under penalty of perjury under California law that the foregoing is true and correct.

Signature

3-1-2021
Date

**(CUPCAA PROJECT) SECTION 00218
CERTIFICATION OF CONTRACTOR AND SUBCONTRACTOR DIVISION OF INDUSTRIAL RELATIONS
REGISTRATION
Modular Classroom Building Renovation RDV
RSD Project # 21-02L**

SECTION 00220

NON-COLLUSION AFFIDAVIT
(CUPCCAA PROJECTS UP TO \$200K)
(Must be submitted with bid)

STATE OF CALIFORNIA
COUNTY OF Orange

I, Edward Mouawad, being first duly sworn, deposes and
(Typed or Printed Name)
says that I am the President of Custom Modular Services Corporation,
(Title) *(Company Name)*

the party submitting the foregoing bid proposal (the "Bidder"). In connection with the foregoing bid proposal ("Bid Proposal"), the undersigned declares, states and certifies that:

1. The Bid Proposal is not made in the interest of, or on behalf of, any undisclosed person, partnership, company, association, organization or corporation.
2. The Bid Proposal is genuine and not collusive or sham.
3. The Bidder has not directly or indirectly induced or solicited any other bidder to put in a false or sham bid, and has not directly or indirectly colluded, conspired, connived, or agreed with any other bidder or anyone else to put in sham bid, or to refrain from bidding.
4. The Bidder has not in any manner, directly or indirectly, sought by agreement, communication, or conference with anyone to fix the bid price, or that of any other bidder, or to fix any overhead, profit or cost element of the bid price or that of any other bidder, or to secure any advantage against the public body awarding the contract or of anyone interested in the proposed contract.
5. All statements contained in the Bid Proposal and related documents are true.
6. The Bidder has not, directly or indirectly, submitted the bid price or any breakdown thereof, or the contents thereof, or divulged information or data relative thereto, or paid, and will not pay, any fee to any person, corporation, partnership, company, association, organization, bid depository, or to any member or agent thereof to effectuate a collusive or sham bid.

Executed this 1st day of March, 2021 at Huntington Beach CA
(City, County and State)

I declare under penalty of perjury under the laws of the State of California that the foregoing is true and correct.

(Signature)

(Address)

Edward Mouawad
(Name Printed or Typed)

(City, State and Zip)

(Area Code and Telephone Number)

(Email)

END OF SECTION

(This page intentionally left blank)

SECTION 00222

**CERTIFICATION OF PREVAILING WAGE AND
RELATED LABOR REQUIREMENTS
(CUPCCAA PROJECTS UP TO \$200K)**

PROJECT/CONTRACT NO.: CUPCCAA)21-02L between Rio School District of Ventura County CA
("District") and Custom Modular Services Corporation ("Contractor"
or "Bidder") ("Contract" or "Project").

I hereby certify that I will conform to the State of California Public Works Contract requirements regarding prevailing wages, benefits, on-site audits with 48-hours notice, payroll records, and apprentice and trainee employment requirements, for all Work on the above Project including, without limitation, labor compliance monitoring and enforcement by the Department of Industrial Relations.

Date: 3/1/21
Proper Name of Contractor: Custom Modular Services Corporation
Contractor Signature: 
Print Name: Edward Mouawad
Title: President

(CUPCCAA PROJECT) Section 00222.
Certification of Prevailing Wage and Related Labor Requirements
Modular Classroom Building Renovation RDV
RSD Project #21-02L

SECTION 00240

**ACKNOWLEDGMENT OF BIDDING
PRACTICES REGARDING INDEMNITY**

(CUPCCAA PROJECTS UP TO \$200K)

TO: Rio School District, 1800 Solar Dr. 3rd Floor, Oxnard, California 93030

RE: Project Number (CUPCCAA) #21-02L

Project Name CUPCCAA) Modular Classroom Building Renovation RDV

Please be advised that with respect to the above-referenced Project, the undersigned Contractor, on behalf of itself and all subcontractors, hereby waives the benefits and protection of Labor Code Section 3864, which provides:

If an action as provided in this chapter prosecuted by the employee, the employer, or both jointly against the third person results in judgment against such third person, or settlement by such third person, the employer shall have no liability to reimburse or hold such third person harmless on such judgment or settlement in absence of a written agreement so to do executed prior to the injury.

This agreement has been signed by an authorized representative of the contracting party and shall be binding upon its successors and assigns. The undersigned further agrees to promptly notify the District of any changes of ownership of the contracting party or any subcontractor while this Agreement is in force.

Custom Modular Services Corporation

Contracting Party

Edward Mouawad/President

Name of Agent/ Title

3/1/21

Date

END OF SECTION

Rio School District
1800 Solar, 3rd Floor
Oxnard, CA 93036
Attn: Dr. John Puglisi, Superintendent

March 2, 2021

Subject: Request for Board Approval to Award Project

Re: RSD Project #21-02L Modular Classroom Building Renovation RDV, Oxnard, Ca.
Recommendation to Award to the Lowest Responsive Bidder

Dear Dr. Puglisi,

The Rio School District received 1 bid for RSD Project #21-02L Modular Classroom Building Renovation RDV.
The following company submitted a bid in the order listed. This Project is tentatively scheduled to be completed by May 10, 2021.

CONTRACTOR	BASE BID	Add Alternate (Not accepted)	Total Bid
<i>Custom Modular</i>	\$197,620.80	n/a	\$197,620.80

It is our recommendation that the Superintendent of Schools, per authorization by the Board of Education at its March 17, 2021 board meeting, proceed with issuing a Notice of Award to Custom Modular Services Corporation.

Should you have any questions or require any additional information, please contact me at any time.

Respectfully,

KH 3/2/2021

Keith Henderson
Senior Project Manager, Balfour Beatty Construction

cc. Wael Saleh Rio S.D.
Dennis Kuykendall BBC
Jesus Meugerza Ibarra BBC

10.21



Agenda Item Details

Meeting	Mar 17, 2021 - RSD Regular Board Meeting
Category	10. Consent
Subject	10.21 Approval of Request to go out to bid for the HVAC Replacement at Rio Del Norte, Project #21-07L
Access	Public
Type	Action (Consent)
Recommended Action	It is recommended that the Board approve Balfour Beatty to go out to bid for the HVAC Replacement project #21-07L at Rio Del Norte

Public Content

Speaker:
Wael Saleh, Assistant Superintendent, Business Services

Rationale:

Balfour Beatty Construction is requesting approval to solicit bids for the HVAC Replacement at Rio Del Norte Elementary School, Project #21-07L. The project has just received DSA Approval and is in the best interest of the Rio School District to approve and move forward with the very important project previously requested as a priority by the Rio Board of Education in an effort to give all Rio campuses air conditioning.

21-07L Request for Board Approval to Bid Project (1) (1).pdf (34 KB)

Administrative Content

Executive Content

Our adopted rules of Parliamentary Procedure, Robert's Rules, provide for a consent agenda listing several items for approval of the Board by a single motion. Most of the items listed under the consent agenda have gone through Board subcommittee review and recommendation. Documentation concerning these items has been provided to all Board members and the public in advance to assure an extensive and thorough review. Items may be removed from the consent agenda at the request of any board member.

Rio School District
1800 Solar, 3rd Floor
Oxnard, CA 93036
Attn; Dr. John Puglisi, Superintendent

March 3, 2021

Subject: Request for Board Approval to Bid HVAC Replacement at Rio Del Norte

Re: RSD Project #21-07L HVAC Replacement at Rio Del Norte Elementary School

Dear Members of the Rio School District Board of Education and Dr. Puglisi,

Balfour Beatty Construction would like to obtain approval from the Rio School Districts Board of Education and Superintendent of the District to move forward with assembling bids, and solicit Contractors for the following Construction project related to the installation of Air Conditioning in Classroom Buildings C, D, H & J that are currently not Air Conditioned at Rio Del Norte Elementary School.

Balfour Beatty Construction is requesting Approval to Solicit Bids for the following Project:

- 1) RSD Project #21-07L HVAC Replacement at Rio Del Norte Elementary School.
The Estimated Budget Cost to Construct this project is \$1,532,000.00

The Project listed above that we have requested approval to bid has just received DSA Approval. Balfour Beatty is of the opinion that it is in the best interest of the Rio School District to approve and move forward with this very important project previously requested as a priority by the Rio Board of Education in an effort to get all RIO campuses fully Air Conditioned.

It is therefore Balfour Beatty Constructions recommendation that the Rio School District Board of Education and the Superintendent of Schools Issue an Approval to Solicit and Bid this Project.

Should you have any questions or require any additional information, please contact me at any time.

Respectfully,

KH 3/3/2021

Keith Henderson
Senior Project Manager, Balfour Beatty Construction

cc. Wael Saleh Rio S.D.
Dennis Kuykendall BBC
Jesus Meugerza Ibarra BBC

10.22



Agenda Item Details

Meeting	Mar 17, 2021 - RSD Regular Board Meeting
Category	10. Consent
Subject	10.22 Approval to go out to Bid for Acoustic Ceiling Installation at Rio Del Norte, Project #21-11L
Access	Public
Type	Action (Consent)
Recommended Action	It is recommended that the Board approve RSD to go out to Bid for the Acoustic Ceiling Installation at Rio Del Norte.

Public Content

Speaker:
Wael Saleh, Assistant Superintendent, Business Services

Rationale:

Balfour Beatty would like to obtain approval from the Rio School District Board of Education and Superintendent to move forward with assembling bids and solicit Contractors for the following Construction project related to the installation of Suspended Acoustical Ceilings in Classroom Buildings C, D, f, J, &H at Rio Del Norte Elementary School. This project is the second part (Phase 2), of the other project to replace the HVAC at Rio Del Norte.

[21-11L Request for Board Approval to Bid Project \(2\) \(3\).pdf \(34 KB\)](#)

Administrative Content

Executive Content

Our adopted rules of Parliamentary Procedure, Robert's Rules, provide for a consent agenda listing several items for approval of the Board by a single motion. Most of the items listed under the consent agenda have gone through Board subcommittee review and recommendation. Documentation concerning these items has been provided to all Board members and the public in advance to assure an extensive and thorough review. Items may be removed from the consent agenda at the request of any board member.

Rio School District
1800 Solar, 3rd Floor
Oxnard, CA 93036
Attn; Dr. John Puglisi, Superintendent

March 3, 2021

Subject: Request for Board Approval to Bid Acoustical Ceiling Installation Project at Rio Del Norte

Re: RSD Project #21-11L Acoustical Ceiling Installation at Rio Del Norte Elementary School

Dear Members of the Rio School District Board of Education and Dr. Puglisi,

Balfour Beatty Construction would like to obtain approval from the Rio School Districts Board of Education and Superintendent of the District to move forward with assembling bids, and solicit Contractors for the following Construction project related to the installation of Suspended Acoustical Ceilings in Classroom Buildings C, D, F, J & H at Rio Del Norte Elementary School. This project is the second part or Phase #2 of the other project to replace the HVAC at Rio Del Norte.

Balfour Beatty Construction is requesting Approval to Solicit Bids for the following Project:

- 1) RSD Project #21-011L Acoustical Ceiling Installation at Rio Del Norte Elementary School.
The Estimated Budget to Construct this project is \$510,000.00

The Project listed above that we have requested approval to bid has had DSA Approval for 3 years. Balfour Beatty is of the opinion that it is in the best interest of the Rio School District to approve and move forward with this very important project as Phase 2 to the HVAC Replacement Project at Rio Del Norte.

It is therefore Balfour Beatty Constructions recommendation that the Rio School District Board of Education and the Superintendent of Schools Issue an Approval to Solicit and Bid this Project.

Should you have any questions or require any additional information, please contact me at any time.

Respectfully,

KH 3/3/2021

Keith Henderson
Senior Project Manager, Balfour Beatty Construction

cc. Wael Saleh Rio S.D.
Dennis Kuykendall BBC
Jesus Meugerza Ibarra BBC

