



SCHOOL

DISTRICT

EDUCATING LEARNERS FOR THE 21ST CENTURY

REGULAR BOARD MEETING

October 21, 2020

**Rio School District
Conference Room
1800 Solar Drive
Oxnard, CA 93030**

**JOHN D. PUGLISI, Ph. D.
Superintendent**

**Board of Education
Linda Armas, President
Eleanor Torres, Clerk
Joe Esquivel
Felix Eisenhower, DMA
Edith Martinez-Cortes**

2.0



Wednesday, October 21, 2020
RSD Regular Board Meeting

Rio School District
1800 Solar Drive
Oxnard, CA 93030

1. Open Session 5:00 p.m.

- 1.1 Call to Order
- 1.2 Pledge of Allegiance
- 1.3 Roll Call

2. Approval of the Agenda

- 2.1 Agenda Correction, Additions, Modifications
- 2.2 Approval of the Agenda

3. Public Comment-Closed Session

3.1 Public Comment (Closed Session) The public may address the Board concerning items that are scheduled for discussion during the closed session only. These presentations are limited to three minutes each, or a total of fifteen minutes in all.

4. Closed Session

- 4.1 Conference Legal Counsel Re Existing Litigation- Martinez v. Newsom, Case No. 5:20-cv-D1796-DMG-KK
- 4.2 Conference with Labor Negotiators [Government Code 54957.6] Agency designated representatives: RSD Negotiating Team; Employee Organization: California School Employee's Association and Rio Teachers' Association
- 4.3 Public Employee Performance Evaluation [Government Code 54957] Title: Staffing 2020/2021
- 4.4 Public Employee Appointment [Government Code 54957] Title: Social Media Coordinator

5. Reconvene Open Session 6:00 p.m.

- 5.1 Report of Closed Session

6. Communications

- 6.1 Acknowledgement of Correspondence to the Board
- 6.2 Board Member Reports
- 6.3 Organizational Reports-RTA/CSEA/Other
- 6.4 Superintendent Report

6.5 Public Comment-Board meetings are meetings of the Governing Board held in public, not public forums, and will be held in a civil, orderly and respectful manner. All public comments or questions should be addressed to the board through the board president. To assure an orderly meeting and an equal opportunity for each speaker, persons wishing to address the Board must fill out a speaker card. Cards are available at the meeting and on the District

website. Cards must be submitted to the Secretary or Clerk of the Board. The speaker may choose to speak during public comment or at the time of the agenda item prior to board consideration. The Governing Board may place limitations on the total time to be devoted to each topic if it finds that the number of speakers would impede the Board's ability to conduct its business in a timely manner. Procedures for receiving communication from the public on topics that fall under the subject jurisdiction of the Governing Board. A member of the public may address the Governing Board on any item(s) on the agenda or non-agenda items. Each person speaking may not exceed a total of three minutes on each item. The speaker may choose to speak during public comment or at the time of the agenda item prior to board consideration. These presentations are limited to three minutes or a total of twenty minutes.

7. Information

7.1 Business Services Report

7.2 Educational Services Report

7.3 School and Systems Improvement Updates

8. Discussion/Action

8.1 Resolution #2021/24 Resolution of the Governing Board Authorizing the Borrowing of funds for Fiscal Year 2020/2021 and the Issuance and sale of one or more Series of 2020/2021 Tax and Revenue Anticipation Notes therefore and Participation in the California School Cash Reserve Program and Requesting the Board of Supervisors of the County to Issue and Sell said Series of Notes.

8.2 Considered approval of a Memorandum of Understanding for the Modified Implementation of the Riverpark Joint Use Agreement at Rio Vista Middle and Rio Del Mar Schools during COVID-19 Emergency

8.3 Approval of Resolution 20/21-29 for the Board of Trustee's Resolution of Intent to Consider the Conveyance of a Right-of-way to the City of Oxnard for Public Streets and Public Utility Purposes for the purpose of obtaining permits for Rio Lindo Staff Parking Lot Project.

8.4 Approval of Resolution 2021/30 Authorizing Emergency Improvement Work Related to Increasing COVID 19 Safety at All District School Sites

9. Consent

9.1 Approval of the Consent Agenda

9.2 Approval of the Minutes of the Regular Board Meeting of September 16, 2020

9.3 Approval of the Minutes of the Special Board Meeting of September 30, 2020

9.4 Approval of the Donation Report

9.5 October 2020 Personnel Report

9.6 Ratification of the Commercial Warrant for September 2, 2020 through October 8, 2020.

9.7 Williams Quarterly Complaint Report

9.8 Approval of Tobacco Use Prevention Education (TUPE) Tier 2 Consortium Grant MOU

9.9 Approval of Migrant Education Program MOU with VCOE

9.10 Preschool Services Contract with Catalyst (Formerly CDI)

9.11 Preschool Services Contract with Child Development Resources of Ventura County

9.12 Approval of CREDIT Change Order 16.1 from KYA Services at Rio Del Sol

9.13 Approval of Change Order 5.3 from K&Z Cabinets, Inc. at Rio Del Sol

9.14 Approval of Change Order from Precision Plumbing Mechanical for Project 20-13L at Rio Plaza.

9.15 Approval of Change Order from Kiwitt's General Building for added scope of work at Rio Rosales

9.16 Approval of Change Order from MM Mechanical for Project #20-12L for work at Rio Real, Rio Del Valle and Rio Rosales

9.17 Approval of Resolution 20/21-16 for the Notice of Completion of Structural Steel by RND Contractors, Inc. at Rio Del Sol

9.18 Approval of Resolution 20/21-17 for the Notice of Completion for Standard Drywall at Rio Del Sol

9.19 Approval of Resolution 20/21-18 for the Notice of Completion of Finish Carpentry and Architectural Woodwork by K&Z Cabinet Co., Inc. at Rio Del Sol

9.20 Approval of Resolution 20/21-19 for the Notice of Completion for Roofing and Sheet Metal by Channel Islands Roofing at Rio Del Sol

9.21 Approval of Resolution 20/21-20 for the Notice of Completion of Floored Tile and Stone at Rio Del Sol

9.22 Approval of Resolution 20/21-21 for the Notice of Completion of the Automatic Fire Sprinkler by JPI Development Group, Inc. at Rio Del Sol

9.23 Approval of Resolution 20/21-22 for the Notice of Completion of Irrigation, Landscape Planting by Pierre Landscape, Inc. at Rio Del Sol

9.24 Approval of Resolution 20/21-23 for the Notice of Completion for flooring by KYA Services LLC at Rio Del Sol

9.25 Notice of Completion and Resolution 20/21-25 for the Accoustical Treatment at RDV Gym by Tech-Wall

9.26 Approval of the Resolution for the Notice of Completion from Pacificom for the new audio system in the RDV gym.

9.27 Approval of Resolution for the Notice of Completion for the bathroom repairs at Rio Rosales by Kiwitt's General Building Contractor at Rio Rosales.

9.28 Approval of Recommendation for a Generator to be installed for RSD and OUHSD

10. Organizational Business

10.1 Future Items for Discussion

10.2 Future Meeting Dates: (Special Board Meeting October 28, 2020), November 18, 2020

11. Adjournment

11.1 Adjournment

4.1



Agenda Item Details

Meeting Oct 21, 2020 - RSD Regular Board Meeting

Category 4. Closed Session

Subject 4.1 Conference Legal Counsel Re Existing Litigation- Martinez v. Newsom, Case No. 5:20-cv-D1796-DMG-KK

Access Public

Type Discussion, Information

Public Content

Speaker:

Rationale:

Administrative Content

Executive Content

4.2



Agenda Item Details

Meeting Oct 21, 2020 - RSD Regular Board Meeting

Category 4. Closed Session

Subject 4.2 Conference with Labor Negotiators [Government Code 54957.6] Agency designated representatives: RSD Negotiating Team; Employee Organization: California School Employee's Association and Rio Teachers' Association

Access Public

Type

Public Content

Speaker:

Rationale:

Administrative Content

Executive Content

4.3



Agenda Item Details

Meeting Oct 21, 2020 - RSD Regular Board Meeting

Category 4. Closed Session

Subject 4.3 Public Employee Performance Evaluation [Government Code 54957] Title: Staffing 2020/2021

Access Public

Type Discussion

Public Content

Speaker:

Rationale:

Administrative Content

Executive Content

4.4



Agenda Item Details

Meeting Oct 21, 2020 - RSD Regular Board Meeting

Category 4. Closed Session

Subject 4.4 Public Employee Appointment [Government Code 54957] Title: Social Media Coordinator

Access Public

Type

Public Content

Speaker:

Rationale:

Administrative Content

Executive Content

6.4



Agenda Item Details

Meeting	Oct 21, 2020 - RSD Regular Board Meeting
Category	6. Communications
Subject	6.4 Superintendent Report
Access	Public
Type	Procedural

Public Content

Speaker: Superintendent Puglisi

Rationale:

Superintendent Puglisi will update the Governing Board on the following:

- Campus ReOpening Plan
- Student Learning Update

Administrative Content

Executive Content

7.1



Agenda Item Details

Meeting	Oct 21, 2020 - RSD Regular Board Meeting
Category	7. Information
Subject	7.1 Business Services Report
Access	Public
Type	Information
Goals	Goal 3-Create welcoming and safe environments where students attend and are connected to their school Goal 1-Improved student achievement at every school and every grade in all content areas

Public Content

Speaker: Wael Saleh, Assistant Superintendent of Business Services

Rationale: Mr. Saleh will update the Governing Board on the following topics:

- Facilities Safety Update

Administrative Content

Executive Content

7.2

**Agenda Item Details**

Meeting	Oct 21, 2020 - RSD Regular Board Meeting
Category	7. Information
Subject	7.2 Educational Services Report
Access	Public
Type	Information
Goals	Goal 1-Improved student achievement at every school and every grade in all content areas Goal 2-Engage parents and other District stakeholders in the development of meaningful partnerships to support student learning.

Public Content

Speaker: Educational Services Staff

Rationale: Educational Staff will provide the Governing Board with the following updates:

- State Assessment System Update

Administrative Content**Executive Content**

7.3

**Agenda Item Details**

Meeting	Oct 21, 2020 - RSD Regular Board Meeting
Category	7. Information
Subject	7.3 School and Systems Improvement Updates
Access	Public
Type	Information

Public Content

Speaker: Carolyn Bernal, Ed.D., Assistant Superintendent of School and Systems Improvement

Rationale:

Dr.Bernal will provide updates on the following:

- Enrollment and Attendance Update
- Revised Distance Learning Schedules
- RiOpening Schedules and Model
- COVID Case Update

Administrative Content**Executive Content**

8.1



Agenda Item Details

Meeting	Oct 21, 2020 - RSD Regular Board Meeting
Category	8. Discussion/Action
Subject	8.1 Resolution #2021/24 Resolution of the Governing Board Authorizing the Borrowing of funds for Fiscal Year 2020/2021 and the Issuance and sale of one or more Series of 2020/2021 Tax and Revenue Anticipation Notes therefore and Participation in the California School Cash Reserve Program and Requesting the Board of Supervisors of the County to Issue and Sell said Series of Notes.
Access	Public
Type	Action
Fiscal Impact	No
Budget Source	General Fund
Recommended Action	It is recommended that the Board approve the Resolution Authorizing the Borrowing of funds for Fiscal Year 2020/2021 and the Issuance and sale of one or more Series of 2020/2021 Tax and Revenue Anticipation Notes therefor and Participation in the California School Cash Reserve Program and Requesting the Board of Supervisors of the County to Issue and Sell said Series of Notes.

Public Content

Speaker:
Wael Saleh, Assistant Superintendent, Business Services

Rationale:

The California School Cash Reserve Program, sponsored by the California School Boards Association Finance Corporation, issues TRANs (Tax and Revenues Anticipation loans) allowing Districts to be able to issue TRANs as part of this cost-effective pooled structure.

TRANs are short-term debt instruments issued by school districts to create an additional cash reserve to the general fund. In our District, this cash reserve will act as a cushion to the general fund in the event that we experience temporary cash flow needs.

The 2020/21 State Adopted Budget was developed with apportionment deferrals to Districts instead of an actual reduction in Funding. These deferrals, if implemented fully, will amount to approximately \$11 million of cash deferred to next fiscal year for the Rio. The district is expected to have cash low points in June, 2021 through a portion of next Fiscal Year.

Issuing a TRAN will protect the district from using other borrowing such as interfund temporary loans or a loan from the county treasurer.

The attached resolution allows the district to move forward with sizing and pricing of the TRAN. As required by AB1200, this information will be submitted to Ventura County Office of Education for their approval of this debt.

Rio ESD TRAN 20-21 Resolution .pdf (342 KB)

Resolution Certificate for TRAN10072020150058.pdf (284 KB)

Administrative Content

Executive Content

THIS RESOLUTION MUST BE DISCUSSED, CONSIDERED AND DELIBERATED BY THE GOVERNING BOARD AS A SEPARATE ITEM OF BUSINESS ON THE GOVERNING BOARD'S AGENDA IN ACCORDANCE WITH CALIFORNIA GOVERNMENT CODE SECTION 53635.7.

DISTRICT RESOLUTION NO 20/21-24

NAME OF DISTRICT: RIO ELEMENTARY SCHOOL DISTRICT *

LOCATED IN: COUNTY OF VENTURA

MAXIMUM AMOUNT OF BORROWING: \$12,000,000

RESOLUTION OF THE GOVERNING BOARD AUTHORIZING THE BORROWING OF FUNDS FOR FISCAL YEAR 2020-2021 AND THE ISSUANCE AND SALE OF ONE OR MORE SERIES OF 2020-2021 TAX AND REVENUE ANTICIPATION NOTES THEREFOR AND PARTICIPATION IN THE CALIFORNIA SCHOOL CASH RESERVE PROGRAM AND REQUESTING THE BOARD OF SUPERVISORS OF THE COUNTY TO ISSUE AND SELL SAID SERIES OF NOTES

WHEREAS, school districts, community college districts and county boards of education are authorized by Sections 53850 to 53858, both inclusive, of the California Government Code (the "Act") (being Article 7.6, Chapter 4, Part 1, Division 2, Title 5 of the Government Code) to borrow money by the issuance of temporary notes; and

WHEREAS, the governing board (the "Board") has determined that, in order to satisfy certain obligations and requirements of the school district, community college district or county board of education specified above (the "District"), a public body corporate and politic located in the County designated above (the "County"), it is desirable that a sum (the "Principal Amount"), not to exceed the Maximum Amount of Borrowing designated above, be borrowed for such purpose during its fiscal year ending June 30, 2021 ("Fiscal Year 2020-2021") by the issuance of its 2020-2021 Tax and Revenue Anticipation Notes (the first series of which shall be referred to herein as the "Series A Notes" and any subsequent series of which shall be referred to herein as "Additional Notes," and collectively with the Series A Notes, the "Notes"), in one or more series (each a "Series"), therefor in anticipation of the receipt by or accrual to the District during Fiscal

* If the Name of the District indicated on the face hereof is not the correct legal name of the District which adopted this Resolution, it shall nevertheless be deemed to refer to the District which adopted this Resolution, and the Name of the District indicated on the face hereof shall be treated as the correct legal name of said District for all purposes in connection with the Program (as hereinafter defined).

Year 2020-2021 of taxes, income, revenue (including, but not limited to, revenue from the state and federal governments), cash receipts and other moneys provided for such fiscal year for the general fund and, if so indicated in a Pricing Confirmation (as defined in Section 4 hereof), capital fund and/or special revenue fund (or similarly named fund or funds as indicated in such Pricing Confirmation) of the District; and

WHEREAS, the Principal Amount may, as determined by the Authorized Officer (as hereinafter defined), be divided into two or more portions evidenced by two or more Series of Notes, which Principal Amount is to be confirmed and set forth in the Pricing Confirmation if one Series of Notes is issued, or if more than one Series of Notes are issued, such Principal Amount will be equal to the sum of the Series Principal Amounts (as defined in Section 2 hereof) as confirmed and set forth in the Pricing Confirmation applicable to each Series of Notes; and

WHEREAS, the District hereby determines to borrow, for the purposes set forth above, the Principal Amount by the issuance, in one or more Series, of the Notes; ** and

WHEREAS, because the District does not have fiscal accountability status pursuant to Section 1080, Section 42647, Section 42650 or Section 85266 of the California Education Code, it requests the Board of Supervisors of the County to borrow, on the District's behalf, the Principal Amount by the issuance of the Notes in one or more Series; and

WHEREAS, pursuant to Section 53853 of the Act, if the Board of Supervisors of the County fails or refuses to authorize the issuance of the Notes within the time period specified in said Section 53853, following receipt of this Resolution, and the Notes, in one or more series, are issued in conjunction with tax and revenue anticipation notes, in one or more series, of other Issuers (as hereinafter defined), the District may issue the Notes, in one or more series, in its name pursuant to the terms stated herein; and

WHEREAS, it appears, and this Board hereby finds and determines, that the Principal Amount, when added to the interest payable thereon, does not exceed eighty-five percent (85%) of the estimated amount of the uncollected taxes, income, revenue (including, but not limited to, revenue from the state and federal governments), cash receipts and other moneys provided for Fiscal Year 2020-2021 which will be received by or which will accrue to the District during such fiscal year for the general fund and, if so indicated in a Pricing Confirmation, capital fund and/or special revenue fund (or similarly named fund or funds as indicated in such Pricing Confirmation) of the District and which will be available for the payment of the principal of each Series of Notes and the interest thereon; and

WHEREAS, no money has heretofore been borrowed by or on behalf of the District through the issuance of tax anticipation notes or temporary notes in anticipation of the receipt of, or payable from or secured by, taxes, income, revenue (including, but not limited to, revenue from the state and federal governments), cash receipts and other moneys provided for Fiscal Year 2020-2021 which will be received by or will accrue to the District during such fiscal year for the general

**** Unless the context specifically requires otherwise, all references to "Series of Notes" herein shall be deemed to refer, to (i) the Note, if issued in one series by the County (or the District, as applicable) hereunder, or (ii) each individual Series of Notes severally, if issued in two or more series by the County (or the District, as applicable) hereunder.**

fund and, if so indicated in a Pricing Confirmation, capital fund and/or special revenue fund (or similarly named fund or funds as indicated in such Pricing Confirmation) of the District; and

WHEREAS, pursuant to Section 53856 of the Act, certain taxes, income, revenue (including, but not limited to, revenue from the state and federal governments), cash receipts and other moneys which will be received by or accrue to the District during Fiscal Year 2020-2021 are authorized to be pledged for the payment of the principal of each Series of Notes (as applicable) and the interest thereon (as hereinafter provided); and

WHEREAS, the District has determined that it is in the best interests of the District to participate in the California School Cash Reserve Program (the "Program"), whereby participating school districts, community college districts and county boards of education (collectively, the "Issuers") will simultaneously issue tax and revenue anticipation notes; and

WHEREAS, the Program has been designed with alternative structures, each of which the District desires to approve; and

WHEREAS, under the first structure (the "Certificate Structure"), the District would issue one or more Series of Notes, each Series of Notes to be marketed with some or all of the notes issued simultaneously by other Issuers participating in the Program, and Piper Sandler & Co., as underwriter for the Program (the "Underwriter"), and Dale Scott & Company, as financial advisor for the Program (the "Financial Advisor"), would form one or more pools of notes or series of certificates (the "Certificates") of participation (the "Series of Certificates") distinguished by (i) whether and what type(s) of Credit Instrument (as hereinafter defined) secures notes comprising each Series of Certificates, and (ii) possibly other features, all of which the District hereby authorizes the Underwriter and the Financial Advisor to determine; and

WHEREAS, the Certificate Structure requires the Issuers participating in any particular Series of Certificates to deposit their applicable series of tax and revenue anticipation notes with U.S. Bank National Association, as trustee (the "Trustee"), pursuant to a trust agreement between such Issuers and the Trustee (the trust agreement applicable to each Series of Certificates, in the form presented to this meeting, with such changes, insertions and omissions as are made pursuant to this Resolution, being referred to herein collectively as, the "Trust Agreement"), and requires the Trustee, pursuant to the Trust Agreement, to execute and deliver the Certificates evidencing and representing proportionate undivided interests in the payments of principal of and interest on the tax and revenue anticipation notes issued by the Issuers comprising such Series of Certificates; and

WHEREAS, if the Certificate Structure is implemented, the District desires to have the Trustee execute and deliver a Series of Certificates which evidences and represents interests of the owners thereof in each Series of Notes issued by the District and the notes issued simultaneously by other Issuers participating in such Series of Certificates; and

WHEREAS, as additional security for the owners of each Series of Certificates, all or a portion of the payments by all of the Issuers of their respective series of notes comprising such Series of Certificates may or may not be secured by an irrevocable letter (or letters) of credit or policy (or policies) of insurance or other credit instrument (or instruments) (collectively, the “Credit Instrument”) issued by the credit provider (or credit providers) (collectively, the “Credit Provider”) designated in the applicable Trust Agreement, as finally executed, pursuant to a credit agreement (or agreements) or commitment letter (or letters) (such credit agreement (or agreements) or commitment letter (or letters), if any, in the forms presented to this meeting, with such changes, insertions and omissions as are made pursuant to this Resolution, being referred to herein collectively as, the “Credit Agreement”) identified in the applicable Trust Agreement, as finally executed, between, in the case of an irrevocable letter (or letters) of credit or policy (or policies) of insurance or other credit instrument (or instruments), the Issuers and the corresponding Credit Provider; and

WHEREAS, pursuant to the Certificate Structure, the Underwriter will submit an offer to purchase each Series of Notes issued by the District and the notes issued by other Issuers participating in the same Series of Certificates all as evidenced and represented by such Series of Certificates (which offer will specify, as designated in the Pricing Confirmation applicable to the sale of such Series of Notes to be sold by the District, the principal amount, interest rate and Credit Instrument (if any)), and has submitted a form of certificate purchase agreement (such certificate purchase agreement, in the form presented to this meeting, with such changes, insertions and omissions as are made pursuant to this Resolution, being referred to herein as, the “Certificate Purchase Agreement”) to the Board; and

WHEREAS, pursuant to the Certificate Structure each participating Issuer will be responsible for its share of (i) the fees of the Trustee and the costs of issuing the applicable Series of Certificates, (ii) if applicable, the fees of the Credit Provider(s), and (iii) if applicable, the Issuer’s allocable share of all Predefault Obligations and the Issuer’s Reimbursement Obligations, if any (each as defined in the Trust Agreement); and

WHEREAS, the Certificate Structure requires that each participating Issuer approve the Trust Agreement, the alternative Credit Instruments and Credit Agreements, if any, and the Certificate Purchase Agreement in substantially the forms presented to the Board, with the final type of Credit Instrument and corresponding Credit Agreement determined in the Pricing Confirmation applicable to the sale of each Series of Notes to be sold by the District; and

WHEREAS, under the second structure (the “Bond Pool Structure”), participating Issuers would be required to sell each series of their tax and revenue anticipation notes to the California School Cash Reserve Program Authority (the “Authority”) pursuant to note purchase agreements (such note purchase agreements, in the form presented to this meeting, with such changes, insertions and omissions as are made pursuant to this Resolution, being referred to herein as, the “Note Purchase Agreements”), each between such individual Issuer and the Authority, and dated as of the date of the Pricing Confirmation applicable to the sale of the individual Issuer’s series of notes to be sold, a form of which has been submitted to the Board; and

WHEREAS, the Authority, pursuant to advice of the Underwriter and the Financial Advisor, will form one or more pools of notes of each participating Issuer (the “Pooled Notes”) and assign each respective series of notes to a particular pool (the “Pool”) and sell a series of senior

bonds (each a “Series of Senior Bonds”) and, if desirable, a corresponding series of subordinate bonds (each a “Series of Subordinate Bonds” and collectively with a Series of Senior Bonds, a “Series of Pool Bonds”) secured by each Pool pursuant to an indenture and/or a supplement thereto (the original indenture and each supplement thereto applicable to a Series of Pool Bonds to which the Note shall be assigned is hereinafter collectively referred to as the “Indenture”) between the Authority and the Trustee, each Series of Pool Bonds distinguished by (i) whether or what type(s) of Credit Instrument(s) secure(s) such Series of Pool Bonds, (ii) the principal amounts or portions of principal amounts of the notes of such respective series assigned to the Pool, or (iii) other factors, and the District hereby acknowledges and approves the discretion of the Authority, acting upon the advice of the Underwriter and the Financial Advisor, to assign the District’s Notes of such respective Series to such Pool and such Indenture as the Authority may determine; and

WHEREAS, at the time of execution of the Pricing Confirmation applicable to the sale of each Series of Notes to be sold by the District, the District will (in such Pricing Confirmation) request the Authority to issue a Series of Pool Bonds pursuant to an Indenture to which such Series of Notes identified in such Pricing Confirmation will be assigned by the Authority in its discretion, acting upon the advice of the Underwriter, which Series of Pool Bonds will be payable from payments of all or a portion of principal of and interest on such Series of Notes and the other respective series of notes of other participating Issuers assigned to the same Pool and assigned to the same Indenture to which the District’s Series of Notes is assigned; and

WHEREAS, as additional security for the owners of each Series of Pool Bonds, all or a portion of the payments by all of the Issuers of the respective series of notes assigned to such Series of Pool Bonds may or may not be secured (by virtue or in form of the Series of Pool Bonds, as indicated in the Pricing Confirmation applicable to such Series of Pool Bonds, being secured in whole or in part) by one or more Credit Instruments issued by one or more Credit Providers designated in the applicable Indenture, as finally executed, pursuant to a Credit Agreement, if any, identified in the applicable Indenture, as finally executed, between, in the case of an irrevocable letter (or letters) of credit or policy (or policies) of insurance or other credit instrument (or instruments), the Issuers and the corresponding Credit Provider; and

WHEREAS, pursuant to the Bond Pool Structure each Issuer, whose series of notes is assigned to a Pool as security for a Series of Pool Bonds, will be responsible for its share of (i) the fees of the Trustee and the costs of issuing the applicable Series of Pool Bonds, (ii), if applicable, the fees of the Credit Provider(s), and (iii) if applicable, the Issuer’s allocable share of all Predefault Obligations and the Issuer’s Reimbursement Obligations, if any (each as defined in the Indenture) applicable to such Series of Pool Bonds; and

WHEREAS, the Bond Pool Structure requires that each participating Issuer approve the Indenture, the alternative Credit Instruments and Credit Agreements, if any, and the Note Purchase Agreement in substantially the forms presented to the Board, with the final type of Credit Instrument and corresponding Credit Agreement, if any, to be determined in the Pricing Confirmation applicable to the sale of each Series of Notes to be sold by the District; and

WHEREAS, pursuant to the Bond Pool Structure, the Underwriter will submit an offer to the Authority to purchase, in the case of each Pool of notes, the Series of Pool Bonds which will be secured by the Indenture to which such Pool will be assigned; and

WHEREAS, all or portions of the net proceeds of each Series of Notes issued by the District, may be invested in one or more Permitted Investments (as defined in the Trust Agreement or the Indenture, as applicable), including under one or more investment agreements with one or more investment providers (if any), the initial investment of which is to be determined in the Pricing Confirmation related to such Series of Notes; and

WHEREAS, it is necessary to engage the services of certain professionals to assist the District in its participation in the Program;

NOW, THEREFORE, the Board hereby finds, determines, declares and resolves as follows:

Section 1. Recitals. All the above recitals are true and correct and this Board so finds and determines.

Section 2. Issuance of Notes.

(A) **Initial Issuance of Notes.** This Board hereby determines to borrow, and hereby requests the Board of Supervisors of the County to borrow for the District, in anticipation of the receipt by or accrual to the District during Fiscal Year 2020-2021 of taxes, income, revenue (including, but not limited to, revenue from the state and federal governments), cash receipts and other moneys provided for such fiscal year for the general fund and, if so indicated in the applicable Pricing Confirmation, the capital fund and/or special revenue fund (or similarly named fund or funds as indicated in such Pricing Confirmation)* of the District, and not pursuant to any common plan of financing of the District, by the issuance by the Board of Supervisors of the County, in the name of the District, of Notes under Sections 53850 *et seq.* of the Act, designated generally as the District's "2020-2021 [Subordinate]** Tax and Revenue Anticipation Notes, Series ___" in one or more of the following Series, in order of priority of payment as described herein:

(1) the Series A Notes, being the initial Series of Notes issued under this Resolution, together with one or more Series of Additional Notes issued in accordance with the provisions of Section 2(B) hereof and payable on a parity with the Series A Notes (collectively, the "Senior Notes"); and

(2) one or more Series of Additional Notes issued in accordance with the provisions of Section 2(B) hereof and payable on a subordinate basis to (i) any Senior Notes, and (ii) any previously issued Subordinate Notes if so specified in the related Pricing Confirmation (collectively, the "Subordinate Notes"), which Subordinate Notes shall be identified as such.

Each such Series of Notes shall be issued in the form of one registered note at the principal amount thereof (the "Series Principal Amount") as set forth in the applicable Pricing Confirmation and all such Series Principal Amounts aggregating to the Principal Amount set forth in such Pricing Confirmations, in each case, to bear a series designation, to be dated the date of its respective delivery to the respective initial purchaser thereof, to mature (without option of prior redemption) not more than thirteen (13) months thereafter on a date indicated on the face thereof and determined in the Pricing Confirmation applicable to such Series of Notes (collectively, the "Maturity Date"),

* For purposes of this Resolution, such funds shall be referred to as the “capital fund” and “special revenue fund.”

** A Series of Notes shall bear the “Subordinate” designation if it is a Series of Subordinate Notes.

and to bear interest, payable at the applicable maturity (and, if the maturity is longer than twelve (12) months, an additional interest payment shall be payable within twelve (12) months of the issue date, as determined in the applicable Pricing Confirmation) and computed upon the basis of a 360day year consisting of twelve 30-day months, at a rate not to exceed twelve percent (12%) per annum as determined in the Pricing Confirmation applicable to such Series of Notes and indicated on the face of such Series of Notes (collectively, the “Note Rate”).

With respect to the Certificate Structure, if a Series of Notes as evidenced and represented by the corresponding Series of Certificates is secured in whole or in part by a Credit Instrument and is not paid at maturity or is paid (in whole or in part) by a draw under, payment by or claim upon a Credit Instrument which draw, payment or claim is not fully reimbursed on such date, such Series of Notes shall become a Defaulted Note (as defined in the Trust Agreement), and the unpaid portion thereof with respect to which a Credit Instrument applies for which reimbursement on a draw, payment or claim has not been fully made shall be deemed outstanding and shall continue to bear interest thereafter until paid at the Default Rate (as defined in the Trust Agreement). If a Series of Notes as evidenced and represented by the corresponding Series of Certificates is unsecured in whole or in part and is not fully paid at the Maturity Date, the unpaid portion thereof (or the portion thereof to which no Credit Instrument applies which is unpaid) shall be deemed outstanding and shall continue to bear interest thereafter until paid at the Default Rate.

With respect to the Bond Pool Structure, if a Series of Pool Bonds issued in connection with a Series of Notes is secured in whole or in part by a Credit Instrument or such Credit Instrument secures the Series of Notes in whole or in part and all principal of and interest on such Series of Notes is not paid in full at maturity or payment of principal of and interest on such Series of Notes is paid (in whole or in part) by a draw under, payment by or claim upon a Credit Instrument which draw, payment or claim is not fully reimbursed on such date, such Series of Notes shall become a Defaulted Note (as defined in the Indenture), and the unpaid portion thereof with respect to which a Credit Instrument applies for which reimbursement on a draw, payment or claim has not been fully made shall be deemed outstanding and shall continue to bear interest thereafter until paid at the Default Rate (as defined in the Indenture). If a Series of Notes or the Series of Pool Bonds issued in connection therewith is not so secured in whole or in part and such Series of Notes is not fully paid at the Maturity Date, the unpaid portion thereof (or the portion thereof to which no Credit Instrument applies which is unpaid) shall be deemed outstanding and shall continue to bear interest thereafter until paid at the Default Rate.

In each case set forth in the preceding two paragraphs, the obligation of the District with respect to such Defaulted Note or unpaid Series of Notes shall not be a debt or liability of the District prohibited by Article XVI, Section 18 of the California Constitution and the District shall not be liable thereon except to the extent of the income and revenue provided for Fiscal Year 20202021 within the meaning of Article XVI, Section 18 of the California Constitution, as provided in Section 8 hereof.

Both the principal of and interest on each Series of Notes shall be payable in lawful money of the United States of America, but only upon surrender thereof, at the corporate trust office of U.S. Bank National Association in Los Angeles, California, or as otherwise indicated in the Trust Agreement or the Indenture, as applicable. The Principal Amount may, prior to the issuance of

any Series of Notes, be reduced from the Maximum Amount of Borrowing specified above, in the discretion of the Underwriter upon consultation with the Authorized Officer. The Principal Amount shall, prior to the issuance of the last Series of Notes, be reduced from the Maximum Amount of Borrowing specified above if and to the extent necessary to obtain an approving legal opinion of Orrick, Herrington & Sutcliffe LLP (“Bond Counsel”) as to the legality thereof or, if applicable, the exclusion from gross income for federal tax purposes of interest thereon (or on any Series of Pool Bonds related thereto). The Principal Amount shall, prior to the issuance of the last Series of Notes, also be reduced from the Maximum Amount of Borrowing specified above, and other conditions shall be met by the District prior to the issuance of each Series of Notes, if and to the extent necessary to obtain from the Credit Provider that issues the Credit Instrument securing the corresponding Series of Certificates evidencing and representing such Series of Notes or the related Series of Pool Bonds to which such Series of Notes is assigned its agreement to issue the Credit Instrument securing such Series of Certificates or Series of Pool Bonds, as the case may be. Notwithstanding anything to the contrary contained herein, if applicable, the approval of the corresponding Credit Provider of the issuance of such Series of Notes and the decision of the Credit Provider to deliver the Credit Instrument shall be in the sole discretion of the Credit Provider, and nothing herein shall be construed to require the Credit Provider to issue a Credit Instrument or to approve the issuance of such Series of Notes.

In the event the Board of Supervisors of the County fails or refuses to authorize the issuance of the Notes within the time period specified in Section 53853 of the Act, following receipt of this Resolution, this Board hereby authorizes issuance of such Notes, in the District’s name, in one or more series, pursuant to the terms stated in this Section 2 and the terms stated hereafter. The Notes, in one or more series, shall be issued in conjunction with the note or notes (in each case, in one or more series) of one or more other Issuers as part of the Program and within the meaning of Section 53853 of the Act.

(B) Issuance of Additional Notes. The District (or the County on its behalf, as applicable) may at any time issue pursuant to this Resolution, one or more Series of Additional Notes consisting of Senior Notes or Subordinate Notes (including Subordinate Notes that are further subordinated to previously issued Subordinate Notes, as provided in the applicable Pricing Confirmation), subject in each case to the following specific conditions, which are hereby made conditions precedent to the issuance of any such Series of Additional Notes:

(1) The District shall not have issued any tax and revenue anticipation notes relating to the 2020-2021 fiscal year except (a) in connection with the Program under this Resolution, or (b) notes secured by a pledge of its Unrestricted Revenues (as defined in Section 8) that is subordinate in all respects to the pledge of its Unrestricted Revenues hereunder; the District shall be in compliance with all agreements and covenants contained herein; and no Event of Default shall have occurred and be continuing with respect to any such outstanding previously issued notes or Series of Notes.

(2) The aggregate Principal Amount of Notes issued and at any time outstanding hereunder shall not exceed any limit imposed by law, by this Resolution or by any resolution of the Board amending or supplementing this Resolution (each a “Supplemental Resolution”).

(3) Whenever the District shall determine to issue, execute and deliver any Additional Notes pursuant to this Section 2(B), the Series Principal Amount of which, when added to the Series Principal Amounts of all Series of Notes previously issued by the District, would exceed the Maximum Amount of Borrowing authorized by this Resolution, the District shall adopt a Supplemental Resolution amending this Resolution to increase the Maximum Amount of Borrowing as appropriate and shall submit such Supplemental Resolution to the Board of Supervisors of the County as provided in Section 53850 *et seq.* of the Act with a request that the County issue such Series of Additional Notes in the name of the District as provided in Sections 2(A) and 9 hereof. The Supplemental Resolution may contain any other provision authorized or not prohibited by this Resolution relating to such Series of Additional Notes.

(4) The District may issue a Series of Additional Notes that are Senior Notes payable on a parity with all other Series of Senior Notes of the District or that are Subordinate Notes payable on a parity with one or more Series of outstanding Subordinate Notes, only if it obtains (a) the consent of each Credit Provider relating to each previously issued Series of Notes that will be on a parity with such Series of Additional Notes, and (b) evidence that no rating then in effect with respect to any outstanding Series of Certificates or Series of Bonds, as applicable, from a Rating Agency will be withdrawn, reduced, or suspended solely as a result of the issuance of such Series of Additional Notes (a "Rating Confirmation"). Except as provided in Section 8, the District may issue one or more Series of Additional Notes that are subordinate to all previously issued Series of Notes of the District without Credit Provider consent or a Rating Confirmation. The District may issue tax and revenue anticipation notes other than in connection with the Program under this Resolution only if such notes are secured by a pledge of its Unrestricted Revenues that is subordinate in all respects to the pledge of its Unrestricted Revenues hereunder.

(5) Before such Additional Notes shall be issued, the District shall file or cause to be filed the following documents with the Trustee:

(a) An Opinion of Counsel to the District to the effect that (A) such Additional Notes constitute the valid and binding obligations of the District, (B) such Additional Notes are special obligations of the District and are payable from the moneys pledged to the payment thereof in this Resolution, and (C) the applicable Supplemental Resolution, if any, has been duly adopted by the District.

(b) A certificate of the District certifying as to the incumbency of its officers and stating that the requirements of this Section 2(B) have been met.

(c) A certified copy of this Resolution and any applicable Supplemental Resolution.

(d) If this Resolution was amended by a Supplemental Resolution to increase the Maximum Amount of Borrowing, the resolution of the County Board of Supervisors approving such increase in the Maximum Amount of Borrowing and the issuance of such Additional Notes, or evidence that the County Board of Supervisors has elected to not issue such Additional Notes.

(e) An executed counterpart or duly authenticated copy of the applicable Certificate Purchase Agreement or Note Purchase Agreement.

(f) A Pricing Confirmation relating to the Series of Additional Notes duly executed by an Authorized Officer (as defined in Section 4).

(g) The Series of Additional Notes duly executed by the applicable County representatives as provided in Section 9 hereof, or executed by the applicable Authorized Officers of the District if the County shall have declined to issue the Series of Additional Notes in the name of the District, either in connection with the initial issuance of the Series A Notes or in connection with any Supplemental Resolution increasing the Maximum Amount of Borrowing.

(h) If the Additional Notes are to be parity Senior Notes or parity Subordinate Notes, the Credit Provider consent(s) and Rating Confirmation(s) required pursuant to paragraph (4) above.

Upon the delivery to the Trustee of the foregoing instruments and, if the Bond Pool Structure is implemented, satisfaction of the provisions of Section 2.12 of the Indenture with regard to the issuance of a corresponding Series of Additional Bonds (as defined therein), the Trustee shall authenticate and deliver said Additional Notes to, or upon the written request of, the District. Upon execution and delivery by the District and authentication by the Trustee, said Additional Notes shall be valid and binding obligations of the District notwithstanding any defects in satisfying any of the foregoing requirements.

(C) Debt Management Policy With Respect to Notes. Notwithstanding any other debt management policy of the District heretofore or hereafter adopted, the debt management policy of the District pertaining to each Series of Notes shall be consistent with, and the Board hereby approves, the following: (i) the proceeds of each Series of Notes may be used and expended by the District for any purpose for which the District is authorized to use and expend moneys, including but not limited to current expenses, capital expenditures, investment and reinvestment, and the discharge of any obligation or indebtedness of the District, as provided by Section 53852 of the Act; (ii) the debt that may be issued pursuant to this debt management policy is limited to each Series of Notes authorized under this Resolution; (iii) each Series of Notes shall be issued to manage the cash flow requirements of the District based on the District's budgetary needs and consistent with the limitations provided for in this Resolution; (iv) the objective of this debt management policy is to implement cost effective cash flow borrowing under the Program for Fiscal Year 2020-2021, whereby participating school districts, community college districts and county boards of education throughout the State of California will simultaneously issue tax and revenue anticipation notes; and (v) to ensure the proceeds of each Series of Notes will be directed to their intended use, moneys allocable to each Series of Notes from the sale of the corresponding Series of Certificates or Pool Bonds, as applicable, net of the District's share of the costs of issuance, shall be deposited in the District's Proceeds Subaccount (as hereinafter defined) attributed to such Series of Notes and held and invested by the Trustee under the Trust Agreement or the Indenture, as applicable, for the District and said moneys may be used and expended by the District for such use upon requisition from such Proceeds Subaccount as specified in the Trust Agreement or the Indenture, as applicable. Any debt management policy adopted by the Board hereafter in contravention of the foregoing shall be deemed to modify the authorization contained

herein only if it shall specifically reference this Resolution and Section. With the passage of this Resolution, the Board hereby certifies that the District has adopted local debt policies with respect to each Series of Notes issued pursuant to this Resolution that comply with California Government Code Section 8855(i), and that the Notes authorized to be issued pursuant to this Resolution are consistent with such policies, and instructs Bond Counsel (as hereinafter defined) to check on behalf of the District the “Yes” box relating thereto in the Report of Proposed Debt Issuance filed pursuant to California Government Code Section 8855 with respect to each Series of Notes issued pursuant to this Resolution.

Section 3. Form of Notes. Each Series of the Notes shall be issued in fully registered form without coupons and shall be substantially in the form and substance set forth in Exhibit A, attached hereto and by reference incorporated herein, the blanks in said form to be filled in with appropriate words and figures.

Section 4. Sale of Notes; Delegation. Any one of the President or Chairperson of the Board, the Superintendent, the Assistant Superintendent for Business, the Assistant Superintendent for Administrative Services, the business manager, director of business or fiscal services or chief financial/business officer of the District, as the case may be, or, in the absence of said officer, his or her duly appointed assistant (each an “Authorized Officer”), is hereby authorized and directed to negotiate, with the Underwriter (if the Certificate Structure is implemented) or the Authority (if the Bond Pool Structure is implemented), an interest rate or rates on each Series of the Notes to the stated maturity or maturities thereof, which shall not, in any individual case, exceed twelve percent (12%) per annum (per Series of Notes), and the purchase price to be paid by the Underwriter or the Authority, as applicable, for the respective Series of the Notes, which purchase price shall be at a discount which when added to the District’s share of the costs of issuance shall not be more than the greater of (a) one percent (1%) of (i) the Principal Amount of the Note, if only one Series of Notes is issued or (ii) the Series Principal Amount of each individual Series of Notes, if more than one series is issued, or (b) five thousand dollars (\$5,000). If such interest rate and price and other terms of the sale of the Series of Notes set out in the Pricing Confirmation applicable to such Series of Notes are acceptable to said Authorized Officer, said Authorized Officer is hereby further authorized and directed to execute and deliver the pricing confirmation supplement applicable to such Series of Notes to be delivered by the Underwriter (on behalf of itself, if the Certificate Structure is implemented and on behalf of the Authority, if the Bond Pool Structure is implemented) to the District on a date within five (5) days, or such longer period of time as agreed by the Underwriter or the Authority, as applicable, of said negotiation of interest rates and purchase price during the period from May 1, 2020 (or the date of adoption of this Resolution if after May 1, 2020) through June 15, 2021 (the “Pricing Confirmation”), substantially in the form presented to this meeting as Schedule I to the Certificate Purchase Agreement or the Note Purchase Agreement, as applicable, with such changes therein as said Authorized Officer shall require or approve, and such other documents or certificates required to be executed and delivered thereunder or to consummate the transactions contemplated hereby or thereby, for and in the name and on behalf of the District, such approval by this Board and such officer to be conclusively evidenced by such execution and delivery. In the event more than one Series of Notes are issued, a separate Pricing Confirmation shall be executed and delivered corresponding to each Series of Notes. Any Authorized Officer is hereby further authorized to execute and deliver, prior to the execution and delivery of the Pricing Confirmation applicable to a Series of Notes, the Certificate Purchase Agreement or the Note Purchase Agreement applicable to such Series of

Notes, substantially in the forms presented to this meeting, which forms are hereby approved, with such changes therein as said officer shall require or approve, such approval to be conclusively evidenced by such execution and delivery; provided, however, that any such Certificate Purchase Agreement or Note Purchase Agreement shall not be effective and binding on the District until the execution and delivery of the corresponding Pricing Confirmation. Delivery of a Pricing Confirmation by fax or telecopy of an executed copy shall be deemed effective execution and delivery for all purposes. If requested by said Authorized Officer at his or her option, any duly authorized deputy or assistant of such Authorized Officer may approve said interest rate or rates and price by execution of the Certificate Purchase Agreement or the Note Purchase Agreement(s), as applicable, and/or the corresponding Pricing Confirmation(s).

Section 5. Program Approval. The District hereby delegates to the Authority the authority to select which structure (*i.e.*, the Certificate Structure or the Bond Pool Structure) shall be implemented, with the Authorized Officer of the District accepting and approving such selection by execution of the applicable Pricing Confirmation.

(A) Certificate Structure. If the Certificate Structure is implemented, each Series of Notes of the District shall be combined with notes of other Issuers into a Series of Certificates as set forth in general terms in the Pricing Confirmation (which need not include specific information about such other notes or Issuers) applicable to such Series of Notes, and shall be marketed and sold simultaneously with such other notes of that Series with such credit support (if any) referred to in the Pricing Confirmation, and shall be evidenced and represented by the Certificates which shall evidence and represent proportionate, undivided interests in such Series of Notes in the proportion that the face amount of such Series of Notes bears to the total aggregate face amount of such Series of Notes and the notes issued by other Issuers which the Series of Certificates represent. Such Certificates may be delivered in book-entry form.

The District hereby delegates to the Authority the authority to select the Credit Instrument(s), Credit Provider(s) and Credit Agreement(s), if any, for each Series of Certificates which evidences and represents interests of the owners thereof in the related Series of Notes of the District and the notes issued by other Issuers evidenced and represented by such Series of Certificates, all of which shall be identified in, and approved by the Authorized Officer of the District executing, the Pricing Confirmation for such Series of Notes, the Trust Agreement and the Credit Agreement(s) (if any), for and in the name and on behalf of the District, such approval of such officer to be conclusively evidenced by the execution of the Pricing Confirmation, the Trust Agreement and the Credit Agreement(s) (if any).

The form of Trust Agreement, alternative general types of Credit Instruments and forms of Credit Agreements, if any, presented to this meeting are hereby approved, and each Authorized Officer is hereby authorized and directed to execute and deliver the Trust Agreement and the Credit Agreement(s), if applicable, which shall be identified in the Pricing Confirmation for the related Series of Notes, in substantially one or more of said forms (a substantially final form of Credit Agreement to be delivered to such Authorized Officer concurrent with the Pricing Confirmation), with such changes therein as said officer shall require or approve, such approval of this Board and such officer to be conclusively evidenced by the execution of the Trust Agreement, Credit Agreement(s) and Pricing Confirmation, respectively.

The form of the Preliminary Official Statement presented to this meeting is hereby approved, and the Underwriter is hereby authorized to distribute the Preliminary Official Statement in connection with the offering and sale of each Series of Certificates. Each Authorized Officer is hereby authorized and directed to provide the Underwriter with such information relating to the District as the Underwriter shall reasonably request for inclusion in the Preliminary Official Statement for each Series of Certificates. Upon inclusion of the information relating to the District therein, the Preliminary Official Statement for the applicable Series of Certificates shall be, except for certain omissions permitted by Rule 15c2-12 of the Securities Exchange Act of 1934, as amended (the "Rule"), deemed final within the meaning of the Rule; provided that no representation is made as to the information contained in a Preliminary Official Statement relating to the other Issuers or any Credit Provider, and the Authority is hereby authorized to certify on behalf of the District that each Preliminary Official Statement is, as of its date, deemed final within the meaning of the Rule. If, at any time prior to the execution of a Pricing Confirmation, any event occurs as a result of which the information contained in the related Preliminary Official Statement relating to the District might include an untrue statement of a material fact or omit to state any material fact necessary to make the statements therein, in light of the circumstances under which they were made, not misleading, the District shall promptly notify the Underwriter. The Authority is hereby authorized and directed, at or after the time of the sale of any Series of Certificates, for and in the name and on behalf of the District, to execute a final Official Statement in substantially the form of the Preliminary Official Statement presented to this meeting, with such additions thereto or changes therein as the Authority may approve, such approval to be conclusively evidenced by the execution and delivery thereof.

The Trustee is authorized and directed to execute each Series of Certificates on behalf of the District pursuant to the terms and conditions set forth in the related Trust Agreement, in the aggregate principal amount specified in the Trust Agreement, and substantially in the form and otherwise containing the provisions set forth in the form of the Certificate contained in the Trust Agreement. When so executed, each Series of Certificates shall be delivered by the Trustee to the Underwriter upon payment of the purchase price thereof, pursuant to the terms of the Trust Agreement and the applicable Certificate Purchase Agreement.

Subject to Section 8 hereof, the District hereby agrees that if a Series of Notes as evidenced and represented by a Series of Certificates shall become a Defaulted Note, the unpaid portion thereof or the portion to which a Credit Instrument applies for which full reimbursement on a draw, payment or claim has not been made by the Maturity Date shall be deemed outstanding and shall not be deemed to be paid until (i) the Credit Provider providing a Credit Instrument with respect to such Series of Certificates, and therefore, if applicable, all or a portion of such Series of Notes, if any, has been reimbursed for any drawings, payments or claims made under the Credit Instrument with respect to such Series of Notes, including interest accrued thereon, as provided therein and in the applicable Credit Agreement, and (ii) the holders of the Series of Certificates which evidence and represent such Series of Notes are paid the full principal amount represented by the unsecured portion of such Series of Notes plus interest accrued thereon (calculated at the Default Rate) to the date of deposit of such aggregate required amount with the Trustee. For purposes of clause (ii) of the preceding sentence, holders of the applicable Series of Certificates will be deemed to have received such principal amount and such accrued interest upon deposit of such moneys with the Trustee.

The District agrees to pay or cause to be paid, in addition to the amounts payable under each Series of Notes, any fees or expenses of the Trustee and, to the extent permitted by law, if such Series of Notes as evidenced and represented by the related Series of Certificates is secured in whole or in part by a Credit Instrument, any Predefault Obligations and Reimbursement Obligations (to the extent not payable under such Series of Notes), (i) arising out of an "Event of Default" hereunder or (ii) arising out of any other event (other than an event arising solely as a result of or otherwise attributable to a default by any other Issuer). In the case described in (ii) above with respect to Predefault Obligations, the District shall owe only the percentage of such fees, expenses and Predefault Obligations equal to the ratio of the Principal Amount (or Series Principal Amount as applicable) of its Series of Notes over the aggregate Principal Amounts (or Series Principal Amounts, as applicable) of all series of notes, including such Series of Notes, of the Series of Certificates of which such Series of Notes is a part, at the time of original issuance of such Series of Certificates. Such additional amounts will be paid by the District within twentyfive (25) days of receipt by the District of a bill therefor from the Trustee.

If the Certificate Structure is implemented, any Authorized Officer is hereby authorized to execute and deliver any Information Return for Tax-Exempt Governmental Obligations, Form 8038-G of the Internal Revenue Service ("Form 8038-G"), in connection with the issuance of a Tax-Exempt (as defined in Section 7) Series of Notes and the related Series of Certificates. To the extent permitted by law, the Authority, the Trustee, the Underwriter, the Financial Advisor and Bond Counsel are each hereby authorized to execute and deliver any Form 8038-G for and on behalf of the District in connection with the issuance of a Tax-Exempt Series of Notes and the related Series of Certificates, as directed by an Authorized Officer of the District.

(B) Bond Pool Structure. If the Bond Pool Structure is implemented, the Pricing Confirmation for a Series of Notes may, but shall not be required to, specify the Series of Pool Bonds to which such Series of Notes will be assigned (but need not include information about other series of notes assigned to the same pool or their Issuers).

The District hereby delegates to the Authority the authority to select the Credit Instrument(s), Credit Provider(s) and Credit Agreement(s), if any, for each Series of Senior Bonds and corresponding Series of Subordinate Bonds, if any, to which each Series of Notes issued by the District will be assigned, all of which shall be identified in, and approved by the Authorized Officer of the District executing, the Pricing Confirmation for such Series of Notes and the Credit Agreement(s) (if any), for and in the name and on behalf of the District, such approval of such officer to be conclusively evidenced by the execution of the Pricing Confirmation and the Credit Agreement(s) (if any).

The alternative general types of Credit Instruments and the forms of Credit Agreements, if any, presented to this meeting are hereby approved, and each Authorized Officer is hereby authorized and directed to execute and deliver a Credit Agreement(s), if any, which shall be identified in the Pricing Confirmation for the related Series of Notes, in substantially one or more of said forms (a substantially final form of Credit Agreement to be delivered to such Authorized Officer concurrent with the Pricing Confirmation), with such changes therein as said officer shall require or approve, such approval of this Board and such officer to be conclusively evidenced by the execution of the Credit Agreement and Pricing Confirmation, respectively.

The form of Indenture presented to this meeting is hereby acknowledged and approved, and it is acknowledged that the Authority will execute and deliver the Indenture and one or more Supplemental Indentures, which shall be identified in the Pricing Confirmation applicable to the Series of Notes to be issued, in substantially one or more of said forms with such changes therein as the Authorized Officer who executes such Pricing Confirmation shall require or approve (substantially final forms of the Indenture and the Supplemental Indenture (if applicable) to be delivered to the Authorized Officer concurrently with the Pricing Confirmation applicable to the Series of Notes to be issued), such approval of such Authorized Officer and this Board to be conclusively evidenced by the execution of the Pricing Confirmation applicable to such Series of Notes. It is acknowledged that the Authority is authorized and requested to issue one or more Series of Pool Bonds (consisting of a Series of Senior Bonds and, if desirable, a corresponding Series of Subordinate Bonds) pursuant to and as provided in the Indenture as finally executed and, if applicable, each Supplemental Indenture as finally executed.

Each Authorized Officer is hereby authorized and directed to provide the Underwriter with such information relating to the District as the Underwriter shall reasonably request for inclusion in the Preliminary Official Statement(s) and Official Statement(s) of the Authority relating to a Series of Pool Bonds. If, at any time prior to the execution of a Pricing Confirmation, any event occurs as a result of which the information contained in the corresponding Preliminary Official Statement or other offering document relating to the District might include an untrue statement of a material fact or omit to state any material fact necessary to make the statements therein, in light of the circumstances under which they were made, not misleading, the District shall promptly notify the Underwriter.

Subject to Section 8 hereof, the District hereby agrees that if a Series of Notes shall become a Defaulted Note, the unpaid portion thereof or the portion to which a Credit Instrument applies for which full reimbursement on a draw, payment or claim has not been made by the Maturity Date shall be deemed outstanding and shall not be deemed to be paid until (i) any Credit Provider providing a Credit Instrument with respect to such Series of Notes or the Series of Pool Bonds issued in connection with such Series of Notes, has been reimbursed for any drawings, payments or claims made under the Credit Instrument with respect to such Series of Notes, including interest accrued thereon, as provided therein and in the applicable Credit Agreement, and (ii) the holders of such Series of Notes or the Series of the Pool Bonds issued in connection with such Series of Notes are paid the full principal amount represented by the unsecured portion of such Series of Notes plus interest accrued thereon (calculated at the Default Rate) to the date of deposit of such aggregate required amount with the Trustee. For purposes of clause (ii) of the preceding sentence, holders of such Series of Pool Bonds will be deemed to have received such principal amount and such accrued interest upon deposit of such moneys with the Trustee.

The District agrees to pay or cause to be paid, in addition to the amounts payable under each Series of Notes, any fees or expenses of the Trustee and, to the extent permitted by law, if such Series of Notes is secured in whole or in part by a Credit Instrument (by virtue of the fact that the corresponding Series of Pool Bonds is secured by a Credit Instrument), any Predefault Obligations and Reimbursement Obligations (to the extent not payable under such Series of Notes), (i) arising out of an "Event of Default" hereunder or (ii) arising out of any other event (other than an event arising solely as a result of or otherwise attributable to a default by any other Issuer). In the case described in (ii) above with respect to Predefault Obligations, the District shall owe only

the percentage of such fees, expenses and Predefault Obligations equal to the ratio of the Principal Amount (or Series Principal Amount as applicable) of its Series of Notes over the aggregate Principal Amounts (or Series Principal Amounts, as applicable) of all series of notes, including such Series of Notes, assigned to the Series of Pool Bonds issued in connection with such Series of Notes, at the time of original issuance of such Series of Pool Bonds. Such additional amounts will be paid by the District within twenty-five (25) days of receipt by the District of a bill therefor from the Trustee.

(C) Appointment of Professionals. Dale Scott & Company (and/or such other firm or firms as shall be selected by the Authority as designated in the applicable Pricing Confirmation and approved and accepted by an Authorized Officer by the execution of such Pricing Confirmation) is hereby appointed and/or approved as financial advisor for the Program, the law firm of Orrick, Herrington & Sutcliffe LLP (and/or such other firm or firms as shall be selected by the Authority as designated in the applicable Pricing Confirmation and approved and accepted by an Authorized Officer by the execution of such Pricing Confirmation) is hereby appointed and/or approved as bond counsel for the Program, Piper Sandler & Co. (and/or such other firm or firms as shall be selected by the Authority as designated in the applicable Pricing Confirmation and approved and accepted by an Authorized Officer by the execution of such Pricing Confirmation) is hereby appointed and/or approved as underwriter for the Program and the law firm of Kutak Rock LLP (and/or such other firm or firms as shall be selected by the Authority as designated in the applicable Pricing Confirmation and approved and accepted by an Authorized Officer by the execution of such Pricing Confirmation) is hereby appointed and/or approved as special counsel to the District in connection with the Program.

Section 6. No Joint Obligation.

(A) Certificate Structure. If the Certificate Structure is implemented, each Series of Notes of the District shall be marketed and sold simultaneously with the notes of other Issuers and shall be aggregated and combined with such notes of other Issuers participating in the Program into a Series of Certificates evidencing and representing an interest in several, and not joint, obligations of each Issuer. The obligation of the District to owners of a Series of Certificates is a several and not a joint obligation and is strictly limited to the District's repayment obligation under this Resolution, the resolution of the County providing for the issuance of the Note, if applicable, and the applicable Series of Notes as evidenced and represented by such Series of Certificates. Owners of Certificates, to the extent of their interest in a Series of Notes, shall be treated as owners of such Series of Notes and shall be entitled to all the rights and security thereof; including the right to enforce the obligations and covenants contained in this Resolution and such Series of Notes. The District hereby recognizes the right of the owners of a Series of Certificates acting directly or through the Trustee to enforce the obligations and covenants contained in the Series of Notes evidenced and represented thereby, this Resolution and the Trust Agreement. The District shall be directly obligated to each owner of a Series of Certificates for the principal and interest payments on the Series of Notes evidenced and represented by such Certificates without any right of counterclaim or offset arising out of any act or failure to act on the part of the Trustee.

(B) Bond Pool Structure. If the Bond Pool Structure is implemented, each Series of Notes will be issued in conjunction with a series of notes of one or more other Issuers and will be assigned to a Pool in order to secure a corresponding Series of Pool Bonds. In all cases, the

obligation of the District to make payments on or in respect to each Series of its Notes is a several and not a joint obligation and is strictly limited to the District's repayment obligation under this Resolution, the resolution of the County providing for the issuance of the Note, if applicable, and such Series of Notes.

Section 7. Disposition of Proceeds of Notes. The moneys received from the sale of each Series of Notes evidenced and represented by a Series of Certificates or each Series of Pool Bonds issued in connection with a Series of Notes, as the case may be, allocable to the District's share of the costs of issuance (which shall include any fees and expenses in connection with the related Credit Instrument(s) applicable to such Series of Notes or Series of Pool Bonds) shall be deposited in an account in the Costs of Issuance Fund established for such Series of Notes or such Series of Pool Bonds, as applicable, and held and invested by the Trustee under the Trust Agreement or the Indenture, as applicable, and expended as directed by the Financial Advisor (if the Certificate Structure is implemented) or the Authority (if the Bond Pool Structure is implemented) on Costs of Issuance as provided in the Trust Agreement or the Indenture, as applicable. The moneys allocable to each Series of Notes from the sale of the corresponding Series of Certificates or Pool Bonds, as applicable, net of the District's share of the costs of issuance, is hereby designated the "Deposit to Proceeds Subaccount" and shall be deposited in the District's Proceeds Subaccount attributed to such Series of Notes hereby authorized to be created pursuant to, and held and invested by the Trustee under, the Trust Agreement or the Indenture, as applicable, for the District and said moneys may be used and expended by the District for any purpose for which it is authorized to use and expend moneys, upon requisition from such Proceeds Subaccount as specified in the Trust Agreement or the Indenture, as applicable. The Pricing Confirmation applicable to each Series of Notes shall set forth such amount of the Deposit to Proceeds Subaccount. Each Authorized Officer is hereby authorized to approve the amount of such Deposit to Proceeds Subaccount. Subject to Section 8 hereof, the District hereby covenants and agrees to replenish amounts on deposit in each Proceeds Subaccount attributed to a Series of its Note to the extent practicable from any source of available funds up to an amount equal to the unreplenished withdrawals from such Proceeds Subaccount.

The Trustee shall transfer to each Payment Account (hereinafter defined) relating to a Series of Notes from amounts on deposit in the related Proceeds Subaccount attributed to such Series of Notes on the first day of each Repayment Period (as defined hereinafter) (or such other day of each Repayment Period designated in the Pricing Confirmation applicable to a Series of Notes), amounts which, taking into consideration anticipated earnings thereon to be received by the Maturity Date, are equal to the percentages of the principal and interest due with respect to such Series of Notes at maturity for the corresponding Repayment Period set forth in such Pricing Confirmation; provided, however, that on the twentieth day of the next to last Repayment Period designated in such Pricing Confirmation (or such other day designated in the Pricing Confirmation applicable to a Series of Notes), or, if only one Repayment Period is applicable to a Series of Notes, on the twentieth day of the month preceding the Repayment Period designated in such Pricing Confirmation (or such other day designated in the Pricing Confirmation applicable to a Series of Notes), the Trustee shall transfer all remaining amounts in the Proceeds Subaccount attributed to the Series of Notes to the related Payment Account all as and to the extent provided in the Trust Agreement or the Indenture, as applicable; provided, however, that with respect to the transfer in or prior to any such Repayment Period, as applicable, if said amount in the Proceeds Subaccount attributed to a Series of Notes is less than the corresponding percentage set forth in the Pricing

Confirmation applicable to the related Series of Notes of the principal and interest due with respect to such Series of Notes at maturity, the Trustee shall transfer to the related Payment Account attributed to such Series of Notes of the District all amounts on deposit in the Proceeds Subaccount attributed to such Series of Notes on the day designated for such Repayment Period.

For Notes issued in calendar year 2020 and issued as Tax-Exempt (or the related Series of Pool Bonds are issued as Tax-Exempt), in the event either (A) the Series Principal Amount of such Notes, together with the aggregate amount of all tax-exempt obligations (including any tax-exempt leases, but excluding private activity bonds), issued and reasonably expected to be issued by the District (and all subordinate entities of the District) during calendar year 2020, will, at the time of the issuance of such Notes (as indicated in the certificate of the District executed as of the date of issuance of such Notes (each "District Certificate")) exceed fifteen million dollars (\$15,000,000), or (B) the Series Principal Amount of such Notes, together with the aggregate amount of all taxexempt obligations not used to finance school construction (including any tax-exempt leases, but excluding private activity bonds), issued and reasonably expected to be issued by the District (and all subordinate entities of the District) during calendar year 2020, will, at the time of the issuance of such Notes (as indicated in the related District Certificate), exceed five million dollars (\$5,000,000), the second following paragraph will apply. In such case, the District shall be deemed a "Safe Harbor Issuer" with respect to such Notes.

For Notes issued in calendar year 2021 and issued as Tax-Exempt (or the related Series of Pool Bonds are issued as Tax-Exempt), in the event either (A) the Series Principal Amount of such Notes, together with the aggregate amount of all tax-exempt obligations (including any tax-exempt leases, but excluding private activity bonds), issued and reasonably expected to be issued by the District (and all subordinate entities of the District) during calendar year 2021, will, at the time of the issuance of such Notes (as indicated in the certificate of the District executed as of the date of issuance of such Notes (each "District Certificate")) exceed fifteen million dollars (\$15,000,000), or (B) the Series Principal Amount of such Notes, together with the aggregate amount of all taxexempt obligations not used to finance school construction (including any tax-exempt leases, but excluding private activity bonds), issued and reasonably expected to be issued by the District (and all subordinate entities of the District) during calendar year 2021, will, at the time of the issuance of such Notes (as indicated in the related District Certificate), exceed five million dollars (\$5,000,000), the following paragraph will apply. In such case, the District shall be deemed a "Safe Harbor Issuer" with respect to such Notes.

Amounts in any Proceeds Subaccount relating to a Tax-Exempt Series of Notes of the District (or any Tax-Exempt Series of Pool Bonds related thereto) and attributable to cash flow borrowing shall be withdrawn and expended by the District for any purpose for which the District is authorized to expend funds from the general fund of the District, but, with respect to general fund expenditures, only to the extent that on the date of any withdrawal no other funds are available for such purposes without legislation or judicial action or without a legislative, judicial or contractual requirement that such funds be reimbursed. If on no date that is within six months from the date of issuance of each Tax-Exempt Series of Notes (or any Tax-Exempt Series of Pool Bonds related thereto), the balance in the related Proceeds Subaccount attributable to cash flow borrowing and treated for federal tax purposes as proceeds of such Tax-Exempt Series of Notes (or such Tax-Exempt Series of Pool Bonds) is low enough so that the amounts in the Proceeds Subaccount attributable to such Tax-Exempt Series of Notes (or such Tax-Exempt Series of Pool

Bonds) qualify for an exception from the rebate requirements (the “Rebate Requirements”) of Section 148 of the Internal Revenue Code of 1986 (the “Code”), the District shall promptly notify the Trustee in writing and, to the extent of its power and authority, comply with instructions from Orrick, Herrington & Sutcliffe LLP, Bond Counsel, supplied to it by the Trustee as the means of satisfying the Rebate Requirements.

The term “Tax-Exempt” shall mean, with respect to interest on any obligations of a state or local government, that such interest is excluded from the gross income of the holders thereof for federal income tax purposes pursuant to Section 103 of the Code, whether or not such interest is includable as an item of tax preference or otherwise includable directly or indirectly for purposes of calculating other tax liabilities, including any alternative minimum tax or environmental tax under the Code. Each Series of Notes issued hereunder (or any Series of Pool Bonds related thereto) may be issued as a Tax-Exempt Series of Notes (or Tax-Exempt Series of Pool Bonds) or such that the interest on such Series of Notes (or such Series of Pool Bonds) is not Tax-Exempt.

Section 8. Source of Payment.

(A) Pledge. The term “Unrestricted Revenues” shall mean the taxes, income, revenue (including, but not limited to, revenue from the state and federal governments), cash receipts and other moneys provided for Fiscal Year 2020-2021 which will be received by or will accrue to the District during such fiscal year for the general fund and, if so indicated in a Pricing Confirmation, capital fund and/or special revenue fund (or similarly named fund or funds as indicated in such Pricing Confirmation) of the District and which are lawfully available for the payment of current expenses and other obligations of the District. As security for the payment of the principal of and interest on all Series of Notes issued hereunder, subject to the payment priority provisions of Section 17 hereof and this Section 8, the District hereby pledges the first Unrestricted Revenues to be received by the District in the periods specified in each Pricing Confirmation as Repayment Periods (each individual period a “Repayment Period” and collectively “Repayment Periods”), in an amount equal to the percentages of the principal and interest due with respect to each Series of Notes at maturity for the corresponding Repayment Period specified in such Pricing Confirmations (the “Pledged Revenues”).

(B) Lien and Charge. As provided in Section 53856 of the Act, all Series of Notes issued hereunder and the interest thereon, subject to the payment priority provisions of Section 17 hereof and this Section 8, shall be a first lien and charge against, and shall be payable from the first moneys received by the District from, the Pledged Revenues.

(C) General Obligation. As provided in Section 53857 of the Act, notwithstanding the provisions of Section 53856 of the Act and of subsection (B) of this Section, all Series of Notes issued hereunder shall be general obligations of the District and, in the event that on the tenth Business Day (as defined in the Trust Agreement or the Indenture, as applicable) of each such Repayment Period (or such other day of each Repayment Period designated in the Pricing Confirmation applicable to a Series of Notes) the District has not received sufficient Unrestricted Revenues to permit the deposit into each Payment Account of the full amount of Pledged Revenues to be deposited therein from said Unrestricted Revenues in such Repayment Period, then the amount of any deficiency shall be satisfied and made up from any other moneys of the District lawfully available for the payment of the principal of all Series of Notes and the interest thereon, as and when such other moneys are received or are otherwise legally available, in the following

order of priority: first, to satisfy pro-rata any deficiencies attributable to any Series of Senior Notes; second, to satisfy pro-rata any deficiencies attributable to any Series of Subordinate Notes (except for any Series of Subordinate Notes described in the next clause); and thereafter, to satisfy any deficiencies attributable to any other Series of Subordinate Notes that shall have been further subordinated to previously issued Series of Subordinate Notes in the applicable Pricing Confirmation, in such order of priority.

(D) Payment Accounts. In order to effect, in part, the pledge provided for in subsection (A) of this Section, the District agrees to the establishment and maintenance as a special fund of the District of a separate Payment Account for each Series of Notes issued hereunder (each a "Payment Account") by the Trustee under the Trust Agreement or the Indenture, as applicable, and the Trustee is hereby appointed as the responsible agent to maintain such fund until the payment of the principal of the corresponding Series of Notes and the interest thereon, and the District hereby covenants and agrees to cause to be deposited directly in each Payment Account (and shall request specific amounts from the District's funds on deposit with the County Treasurer for such purpose) a pro-rata share (as provided below) of the first Unrestricted Revenues received in each Repayment Period specified in the Pricing Confirmation(s) and any Unrestricted Revenues received thereafter until the amount on deposit in each Payment Account, taking into consideration anticipated investment earnings thereon to be received by the Maturity Date applicable to the respective Series of Notes (as set forth in a certificate from the Financial Advisor to the Trustee), is equal in the respective Repayment Periods identified in the Pricing Confirmation applicable to such Series of Notes to the percentages of the principal of and interest due with respect to such Series of Notes at maturity specified in the Pricing Confirmation applicable to such Series of Notes; provided that such deposits shall be made in the following order of priority: first, pro-rata to the Payment Account(s) attributable to any applicable Series of Senior Notes; second, pro-rata to the Payment Account(s) attributable to any applicable Series of Subordinate Notes (except for any Series of Subordinate Notes described in the next clause); and thereafter, to the Payment Account(s) attributable to any other applicable Series of Subordinate Notes that shall have been further subordinated to previously issued Series of Subordinate Notes in the applicable Pricing Confirmation, in such order of priority.

Subject to the payment priority provisions of Section 17 hereof and this Section 8, any moneys placed in the Payment Account attributed to a Series of Notes shall be for the benefit of (i) the owners of the applicable Series of Certificates if the Certificate Structure is implemented and the holders of the Series of Pool Bonds issued in connection with the Pool of which such Series of Notes is a part if the Bond Pool Structure is implemented, and (ii) (to the extent provided in the Trust Agreement or the Indenture, as applicable) the Credit Provider(s), if any. Subject to the payment priority provisions of Section 17 hereof and this Section 8, the moneys in the Payment Account attributed to the Series of Notes shall be applied only for the purposes for which the Payment Account is created until the principal of such Series of Notes and all interest thereon are paid or until provision has been made for the payment of the principal of such Series of Notes at maturity of such Series of Notes with interest to maturity (in accordance with the requirements for defeasance of the related Series of Certificates or Series of Bonds, as applicable, as set forth in the Trust Agreement or the Indenture, as applicable) and, if applicable (to the extent provided in the Trust Agreement or the Indenture, as applicable, and, if applicable, the corresponding Credit Agreement), the payment of all Predefault Obligations and Reimbursement Obligations owing to the corresponding Credit Provider.

(E) Determination of Repayment Periods. With respect to each Series of Notes, the length of any individual Repayment Period determined in the related Pricing Confirmation shall not exceed the greater of three (3) consecutive calendar months or ninety (90) days and the number of Repayment Periods determined in the related Pricing Confirmation shall not exceed six (6); provided, however, that (1) the first Repayment Period of any Series of Subordinate Notes shall not occur prior to the end of the last Repayment Period of any outstanding Series of Notes of a higher priority without the consent of each Credit Provider for such outstanding Notes; and (2) if the first Repayment Period of any Series of Subordinate Notes overlaps the last Repayment Period of any outstanding Series of Notes of a higher priority, no deposits shall be made in the Payment Account of such Subordinate Notes until all required amounts shall have been deposited into the Payment Account(s) of all outstanding Series of Notes of a higher priority without the consent of each Credit Provider for such outstanding Notes. Any Authorized Officer is hereby authorized to approve the determination of the Repayment Periods and percentages of the principal and interest due with respect to each Series of Notes at maturity required to be on deposit in the related Payment Account in each Repayment Period, all as specified in the Pricing Confirmation applicable to such Series of Notes, by executing and delivering the Pricing Confirmation applicable to such Series of Notes, such execution and delivery to be conclusive evidence of approval by this Board and such Authorized Officer.

(F) Application of Moneys in Payment Accounts. On any interest payment date (if different from the Maturity Date) and on the Maturity Date of a Series of Notes, the moneys in the Payment Account attributed to such Series of Notes shall be transferred by the Trustee, to the extent necessary, to pay, in the case of an interest payment date, the interest, and in the case of the Maturity Date, the principal of and interest with respect to such Series of Notes or to reimburse the Credit Provider(s) for payments made under or pursuant to the Credit Instrument(s), subject to the payment priority provisions of Section 17 hereof and this Section 8. In the event that moneys in the Payment Account attributed to any Series of Notes are insufficient to pay the principal of and/or interest with respect to such Series of Notes in full on an interest payment date and/or the Maturity Date, moneys in such Payment Account together with moneys in the Payment Accounts of all other outstanding Series of Notes issued by the District shall be applied in the following priority:

- (1) with respect to all Series of Senior Notes:
 - a. first, to pay interest with respect to all Series of Senior Notes pro-rata;
 - b. second, (if on the Maturity Date) to pay principal of all Series of Senior Notes pro-rata;
 - c. third, to reimburse each Credit Provider for payment, if any, of interest with respect to all Series of Senior Notes pro-rata (or on such other basis as set for in the Trust Agreement or the Indenture, as applicable);
 - d. fourth, to reimburse each Credit Provider for payment, if any, of principal with respect to all Series of Senior Notes pro-rata (or on such other basis as set for in the Trust Agreement or the Indenture, as applicable);

- e. fifth, to pay pro-rata (or on such other basis as set for in the Trust Agreement or the Indenture, as applicable) any Reimbursement Obligations of the District and any of the District's pro rata share of Predefault Obligations owing to each Credit Provider relating to all Series of Senior Notes, as applicable;
- (2) then, with respect to all Series of Subordinate Notes (except for any Series of Subordinate Notes described in paragraph (3) below), to make the pro-rata payments corresponding to each such Series of Subordinate Notes equivalent to the payments described above in paragraphs (1)(a) through (e), in such order;
- (3) then, with respect to all other Series of Subordinate Notes that have been further subordinated to previously issued Series of Subordinate Notes in the applicable Pricing Confirmation, to make the pro-rata payments corresponding to each such Series of Subordinate Notes equivalent to the payments described above in paragraphs (1)(a) through (e), in such order; and
- (4) lastly, to pay any other Costs of Issuance not previously disbursed.

Any moneys remaining in or accruing to the Payment Account attributed to each such Series of Notes after the principal of all the Series of Notes and the interest thereon and any Predefault Obligations and Reimbursement Obligations, if applicable, and obligation, if any, to pay any rebate amounts in accordance with the provisions of the Trust Agreement or the Indenture, as applicable, have been paid, or provision for such payment has been made, if any, shall be transferred by the Trustee to the District, subject to any other disposition required by the Trust Agreement, the Indenture or the related Credit Agreement(s), as applicable.

Nothing herein shall be deemed to relieve the District from its obligation to pay its Note of any Series in full on the applicable Maturity Date(s).

(G) Investment of Moneys in Proceeds Subaccounts and Payment Accounts. Moneys in the Proceeds Subaccount attributed to each Series of Notes and the Payment Account attributed to such Series of Notes shall be invested by the Trustee pursuant to the Trust Agreement or the Indenture, as applicable, in an investment agreement or agreements and/or other Permitted Investments as described in and under the terms of the Trust Agreement or the Indenture, as applicable, and as designated in the Pricing Confirmation applicable to such Series of Notes. The type of initial investments to be applicable to the proceeds of the Series of Notes shall be determined by the District as designated in the Pricing Confirmation applicable to such Series of Notes. In the event the District designates an investment agreement or investment agreements as the investments, the District hereby appoints the bidding agent designated in the Pricing Confirmation (the "Bidding Agent") as its designee as a party authorized to solicit bids on or negotiate the terms of the investment agreement or investment agreements and hereby authorizes and directs the Trustee to invest such funds pursuant to such investment agreement or investment agreements (which (i) shall be with a provider or providers, or with a provider or providers whose obligations are guaranteed or insured by a financial entity, the senior debt or investment contracts or obligations under its investment contracts of which are rated in one of the two highest long-term rating categories by the rating agency or agencies then rating the applicable Series of Certificates or Series of Pool Bonds (each, a "Rating Agency"), or whose commercial paper rating is in the

highest rating category (with regard to any modifiers) of each such Rating Agencies, or (ii) shall be fully collateralized by investments listed in subsection (1) of the definition of Permitted Investments set forth in the Trust Agreement or the Indenture, as applicable, as required by such Rating Agencies to be rated in one of the two highest rating categories, and shall be acceptable to the corresponding Credit Provider, if any, and the particulars of which pertaining to interest rate or rates and investment provider or providers will be set forth in the Pricing Confirmation applicable to such Series of Notes) and authorizes the Trustee to enter into such investment agreement or agreements on behalf of the District. The Bidding Agent, on behalf of itself and any investment broker retained by it, is authorized to accept a fee from the investment provider in an amount not in excess of 0.2% of the amount reasonably expected, as of the date of acquisition of the investment contract, to be invested under the investment contract over its term. Each Authorized Officer is hereby authorized and directed to execute and deliver such side letter or letters as are reasonably required by an investment agreement provider, acknowledging such investment and making reasonable representations and covenants with respect thereto. The District's funds in the Proceeds Subaccount attributed to each Series of Notes and the Payment Account attributed to such Series of Notes shall be accounted for separately. Any such investment by the Trustee shall be for the account and risk of the District, and the District shall not be deemed to be relieved of any of its obligations with respect to any Series of Notes, the Predefault Obligations or Reimbursement Obligations, if any, by reason of such investment of the moneys in its Proceeds Subaccount applicable to such Series of Notes or the Payment Account applicable to such Series of Notes.

Notwithstanding any other investment policy of the District heretofore or hereafter adopted, the investment policy of the District pertaining to each Series of Notes and all funds and accounts established in connection therewith shall be consistent with, and the Board hereby authorizes investment in, the Permitted Investments. Any investment policy adopted by the Board hereafter in contravention of the foregoing shall be deemed to modify the authorization contained herein only if it shall specifically reference this Resolution and Section.

Section 9. Execution of Note. Any one of the Treasurer of the County, or, in the absence of said officer, his or her duly appointed assistant, the Chairperson of the Board of Supervisors of the County or the Auditor (or comparable financial officer) of the County shall be authorized to execute each Note of any Series issued hereunder by manual or facsimile signature and the Clerk of the Board of Supervisors of the County or any Deputy Clerk shall be authorized to countersign each such Note by manual or facsimile signature and to affix the seal of the County to each such Note either manually or by facsimile impression thereof. In the event the Board of Supervisors of the County fails or refuses to authorize issuance of the Series of Notes as referenced in Section 2 hereof, any one of the President or Chairperson of the governing board of the District or any other member of such board shall be authorized to execute the Note by manual or facsimile signature and the Secretary or Clerk of the governing board of the District, the Superintendent of the District, the Assistant Superintendent for Business, the Assistant Superintendent for Administrative Services, the business manager, director of business or fiscal services or chief financial/business officer of the District, as the case may be, or any duly appointed assistant thereto, shall be authorized to countersign each such Note by manual or facsimile signature. Said officers of the County or the District, as applicable, are hereby authorized to cause the blank spaces of each such Note to be filled in as may be appropriate pursuant to the applicable Pricing Confirmation. Said officers are hereby authorized and directed to cause the Trustee, as registrar and authenticating

agent, to authenticate and accept delivery of each such Note pursuant to the terms and conditions of the corresponding Certificate Purchase Agreement or Note Purchase Agreement, as applicable, this Resolution and the Trust Agreement or Indenture, as applicable. In case any officer whose signature shall appear on any Series of Notes shall cease to be such officer before the delivery of such Series of Notes, such signature shall nevertheless be valid and sufficient for all purposes, the same as if such officer had remained in office until delivery. Each Series of the Notes shall have thereon a certificate of authentication substantially in the form hereinafter set forth duly executed by the Trustee and showing the date of authentication. Each Series of the Notes shall not be valid or obligatory for any purpose or be entitled to any security or benefit under this Resolution unless and until such certificate of authentication shall have been duly executed by the Trustee by manual signature, and such certificate of authentication upon any such Series of Notes shall be conclusive evidence that such has been authenticated and delivered under this Resolution. The certificate of authentication on a Series of Notes shall be deemed to have been executed by the Trustee if signed by an authorized officer of the Trustee. The Notes need not bear the seal of the District, if any.

Section 10. Note Registration and Transfer. (A) As long as any Series of the Notes remains outstanding, the District shall maintain and keep, at the principal corporate trust office of the Trustee, books for the registration and transfer of each Series of the Notes. Each Series of the Notes shall initially be registered in the name of the Trustee under the Trust Agreement or Indenture, as applicable, to which such Series of the Notes is assigned. Upon surrender of a Note of a Series for transfer at the office of the Trustee with a written instrument of transfer satisfactory to the Trustee, duly executed by the registered owner or its duly authorized attorney, and upon payment of any tax, fee or other governmental charge required to be paid with respect to such transfer, the County or the District, as applicable, shall execute and the Trustee shall authenticate and deliver, in the name of the designated transferee, a fully registered Note of the same Series. For every transfer of a Note of a Series, the District, the County or the Trustee may make a charge sufficient to reimburse it for any tax, fee or other governmental charge required to be paid with respect to the transfer, which sum or sums shall be paid by the person requesting such transfer as a condition precedent to the exercise of the privilege of making such transfer.

(B) Subject to Section 6 hereof, the County, the District and the Trustee and their respective successors may deem and treat the person in whose name a Note of a Series is registered as the absolute owner thereof for all purposes, and the County, the District and the Trustee and their respective successors shall not be affected by any notice to the contrary, and payment of or on account of the principal of such Note shall be made only to or upon the order of the registered owner thereof. All such payments shall be valid and effectual to satisfy and discharge the liability upon such Note to the extent of the sum or sums so paid.

(C) Any Note of a Series may, in accordance with its terms, be transferred upon the books required to be kept by the Trustee, pursuant to the provisions hereof by the person in whose name it is registered, in person or by his duly authorized attorney, upon surrender of such Note for cancellation, accompanied by delivery of a written instrument of transfer, duly executed in form approved by the Trustee.

(D) The Trustee or the Authorized Officer of the District, acting separately or together, are authorized to sign any letter or letters of representations which may be required in connection with the delivery of any Series of Certificates or Series of Pool Bonds (in each case, to which such

Series of Notes is assigned), if such Series of Certificates and Series of Pool Bonds are delivered in book-entry form.

(E) The Trustee will keep or cause to be kept, at its principal corporate trust office, sufficient books for the registration and transfer of each Note of a Series issued, which shall be open to inspection by the County and the District during regular business hours. Upon presentation for such purpose, the Trustee shall, under such reasonable regulations as it may prescribe, register or transfer or cause to be registered or transferred, on such books, the Notes of a Series presented as hereinbefore provided.

(F) If any Note of a Series shall become mutilated, the County or the District, as applicable, at the expense of the registered owner of such Note of a Series, shall execute, and the Trustee shall thereupon authenticate and deliver a new Note of like tenor, series and number in exchange and substitution for the Note so mutilated, but only upon surrender to the Trustee of the Note so mutilated. Every mutilated Note so surrendered to the Trustee shall be cancelled by it and delivered to, or upon the order of, the County or the District, as applicable. If any Note of a Series shall be lost, destroyed or stolen, evidence of such loss, destruction or theft may be submitted to the County, the District and the Trustee and, if such evidence be satisfactory to them and indemnity satisfactory to them shall be given, the County or the District, as applicable, at the expense of the registered owner, shall execute, and the Trustee shall thereupon authenticate and deliver a new Note of like tenor, series and number in lieu of and in substitution for the Note so lost, destroyed or stolen (or if any such Note of a Series shall have matured (as of the latest maturity date indicated on the face thereof) or shall be about to mature (as of the latest maturity date indicated on the face thereof), instead of issuing a substitute Note, the Trustee may pay the same without surrender thereof). The Trustee may require payment of a sum not exceeding the actual cost of preparing each new Note issued pursuant to this paragraph and of the expenses which may be incurred by the County or the District, as applicable, and the Trustee in such preparation. Any Note of a Series issued under these provisions in lieu of any Note of a Series alleged to be lost, destroyed or stolen shall constitute an original additional contractual obligation on the part of the County (on behalf of the District) or on the part of the District, as applicable, whether or not the Note of a Series so alleged to be lost, destroyed or stolen be at any time enforceable by anyone, and shall be entitled to the benefits of this Resolution with all other Notes of the same Series secured by this Resolution.

Section 11. Covenants Regarding Transfer of Funds. It is hereby covenanted and warranted by the District that it will not request the County Treasurer to make temporary transfers of funds in the custody of the County Treasurer to meet any obligations of the District during Fiscal Year 2020-2021 pursuant to Article XVI, Section 6 of the Constitution of the State of California; provided, however, that the District may request the County Treasurer to make such temporary transfers of funds if all amounts required to be deposited into the Payment Account(s) of all outstanding Series of Notes (regardless of when due and payable) shall have been deposited into such Payment Account(s).

Section 12. Representations and Covenants.

(A) The District is a political subdivision duly organized and existing under and by virtue of the laws of the State of California and has all necessary power and authority to (i) adopt this Resolution and any supplement hereto, and enter into and perform its obligations under the Certificate Purchase Agreement(s) or the Note Purchase Agreement(s), as applicable, the Trust

Agreement(s), if applicable, and the Credit Agreement(s), if applicable, and (ii) authorize the County to issue one or more Series of Notes on its behalf or, if applicable, issue one or more Series of Notes.

(B) (i) Upon the issuance of each Series of Notes, the District will have taken all action required to be taken by it to authorize the issuance and delivery of such Series of Notes and the performance of its obligations thereunder, (ii) the District has full legal right, power and authority to request the County to issue and deliver such Series of Notes on behalf of the District and to perform its obligations as provided herein and therein, and (iii) if applicable, the District has full legal right, power and authority to issue and deliver each Series of Notes.

(C) The issuance of each Series of Notes, the adoption of this Resolution and the execution and delivery of the Certificate Purchase Agreement(s) or the Note Purchase Agreement(s), as applicable, the Trust Agreement(s), if applicable, and the Credit Agreement(s), if applicable, and compliance with the provisions hereof and thereof will not conflict with, breach or violate any law, administrative regulation, court decree, resolution, charter, by-laws or other agreement to which the District is subject or by which it is bound.

(D) Except as may be required under blue sky or other securities law of any state or Section 3(a)(2) of the Securities Act of 1933, there is no consent, approval, authorization or other order of, or filing with, or certification by, any regulatory authority having jurisdiction over the District required for the issuance and sale of each Series of Notes or the consummation by the District of the other transactions contemplated by this Resolution except those the District shall obtain or perform prior to or upon the issuance of each Series of Notes.

(E) The District has (or will have prior to the issuance of the first Series of Notes) duly, regularly and properly adopted a budget for Fiscal Year 2020-2021 setting forth expected revenues and expenditures and has (or will have prior to the issuance of the first Series of Notes) complied with all statutory and regulatory requirements with respect to the adoption of such budget. The District hereby covenants that it will (i) duly, regularly and properly prepare and adopt its revised or final budget for Fiscal Year 2020-2021, (ii) provide to the Trustee, the Credit Provider(s), if any, the Underwriter and the Financial Advisor, promptly upon adoption, copies of such revised or final budget and of any subsequent revisions, modifications or amendments thereto and (iii) comply with all applicable law pertaining to its budget.

(F) The County has experienced an *ad valorem* property tax collection rate of not less than eighty-five percent (85%) of the average aggregate amount of *ad valorem* property taxes levied within the District in each of the five fiscal years from Fiscal Year 2014-2015 through Fiscal Year 2018-2019, and the District, as of the date of adoption of this Resolution and on the date of issuance of each Series of Notes, reasonably expects the County to have collected and to collect at least eighty-five percent (85%) of such amount for Fiscal Years 2019-2020 and 2020-2021, respectively.

(G) The District (i) is not currently in default on any debt obligation, (ii) to the best knowledge of the District, has never defaulted on any debt obligation, and (iii) has never filed a petition in bankruptcy.

(H) The District's most recent audited financial statements present fairly the financial condition of the District as of the date thereof and the results of operation for the period covered thereby. Except as has been disclosed to the Underwriter and the Credit Provider(s), if any, there has been no change in the financial condition of the District since the date of such audited financial statements that will in the reasonable opinion of the District materially impair its ability to perform its obligations under this Resolution and each Series of Notes. The District agrees to furnish to the Underwriter, the Financial Advisor, the Trustee and the Credit Provider(s), if any, promptly, from time to time, such information regarding the operations, financial condition and property of the District as such party may reasonably request.

(I) There is no action, suit, proceeding, inquiry or investigation, at law or in equity, before or by any court, arbitrator, governmental or other board, body or official, pending or, to the best knowledge of the District, threatened against or affecting the District questioning the validity of any proceeding taken or to be taken by the District in connection with each Series of Notes, the Certificate Purchase Agreement(s) or the Note Purchase Agreement(s), as applicable, the Trust Agreement or the Indenture, as applicable, the Credit Agreement(s), if any, or this Resolution, or seeking to prohibit, restrain or enjoin the execution, delivery or performance by the District of any of the foregoing, or wherein an unfavorable decision, ruling or finding would have a materially adverse effect on the District's financial condition or results of operations or on the ability of the District to conduct its activities as presently conducted or as proposed or contemplated to be conducted, or would materially adversely affect the validity or enforceability of, or the authority or ability of the District to perform its obligations under, each Series of Notes, the Certificate Purchase Agreement(s) or the Note Purchase Agreement(s), as applicable, the Trust Agreement or the Indenture, as applicable, the Credit Agreement(s), if any, or this Resolution.

(J) The District will not directly or indirectly amend, supplement, repeal, or waive any portion of this Resolution (i) without the consents of the Credit Provider(s), if any, or (ii) in any way that would materially adversely affect the interests of any holder or owner of any Series of the Notes, Certificates or Pool Bonds, as applicable, issued in connection with any Series of the Notes; provided, however that, if the Program is implemented, the District may adopt one or more Supplemental Resolutions without any such consents in order to increase the Maximum Amount of Borrowing in connection with the issuance of one or more Series of Additional Notes as provided in Section 2(B)(4) hereof.

(K) Upon issuance of a Series of Notes, such Series of Notes, this Resolution and the corresponding Credit Agreement will constitute legal, valid and binding agreements of the District, enforceable in accordance with their respective terms, except as such enforceability may be limited by bankruptcy or other laws affecting creditors' rights generally, the application of equitable principles if equitable remedies are sought, the exercise of judicial discretion in appropriate cases and the limitations on legal remedies against school districts, community college districts and county boards of education, as applicable, in the State of California.

(L) It is hereby covenanted and warranted by the District that all representations and recitals contained in this Resolution are true and correct, and that the District and its appropriate officials have duly taken, or will take, all proceedings necessary to be taken by them, if any, for the levy, receipt, collection and enforcement of the Pledged Revenues in accordance with law for carrying out the provisions of this Resolution and each Series of Notes.

(M) The District shall not incur any indebtedness that is not issued in connection with the Program under this Resolution and that is secured by a pledge of its Unrestricted Revenues unless such pledge is subordinate in all respects to the pledge of Unrestricted Revenues hereunder.

(N) So long as any Credit Provider is not in default under the corresponding Credit Instrument, the District hereby agrees to pay its pro rata share of all Predefault Obligations and all Reimbursement Obligations attributable to the District in accordance with provisions of the applicable Credit Agreement, if any, and/or the Trust Agreement or Indenture, as applicable. Prior to the Maturity Date of a Series of Notes, moneys in the District's Payment Account attributed to such Series of Notes shall not be used to make such payments. The District shall pay such amounts promptly upon receipt of notice from the Credit Provider that such amounts are due to it by instructing the Trustee to pay such amounts to the Credit Provider on the District's behalf by remitting to the Credit Provider moneys held by the Trustee for the District and then available for such purpose under the Trust Agreement or the Indenture, as applicable. If such moneys held by the Trustee are insufficient to pay the District's pro rata share of such Predefault Obligations and all Reimbursement Obligations attributable to the District (if any), the District shall pay the amount of the deficiency to the Trustee for remittance to the Credit Provider.

(O) So long as any Series of Certificates or Pool Bonds executed or issued in connection with a Series of Notes are Outstanding, or any Predefault Obligation or Reimbursement Obligation is outstanding, the District will not create or suffer to be created any pledge of or lien on such Series of Notes other than the pledge and lien of the Trust Agreement or the Indenture, as applicable.

(P) As of the date of adoption of this Resolution, based on the most recent report prepared by the Superintendent of Public Instruction of the State of California, the District does not have a negative certification (or except as disclosed in writing to the Underwriter and the Credit Provider(s), if any, a qualified certification) applicable to the fiscal year ending June 30, 2020 (the "Fiscal Year 2019-2020") within the meaning of Section 42133 of the California Education Code. The District covenants that it will immediately deliver a written notice to the Authority, the Underwriter, the Financial Advisor, the Credit Provider(s), if any, and Bond Counsel if it (or, in the case of County Boards of Education, the County Superintendent of Schools) files with the County Superintendent of Schools, the County Board of Education or the State Superintendent of Public Instruction or receives from the County Superintendent of Schools or the State Superintendent of Public Instruction a qualified or negative certification applicable to Fiscal Year 2019-2020 or Fiscal Year 2020-2021 prior to the respective Closing Date referenced in each Pricing Confirmation or the Maturity Date of each Series of Notes.

(Q) The District will maintain a positive general fund balance in Fiscal Year 2020-2021.

(R) The District will maintain an investment policy consistent with the policy set forth in Section 8(G) hereof.

(S) The District covenants that it will immediately deliver a written notice to the Authority, the Underwriter, the Financial Advisor, the Credit Provider(s), if any, and Bond Counsel upon the occurrence of any event which constitutes an Event of Default hereunder or would constitute an Event of Default but for the requirement that notice be given, or time elapse, or both.

Section 13. Tax Covenants. (A) The District will not take any action or fail to take any action if such action or failure to take such action would adversely affect the exclusion from gross income of the interest payable on each Tax-Exempt Series of Notes (or on any Tax-Exempt Series of Pool Bonds related thereto) under Section 103 of the Code. Without limiting the generality of the foregoing, the District will not make any use of the proceeds of any Tax-Exempt Series of the Notes or any other funds of the District which would cause any Tax-Exempt Series of the Notes (or on any Tax-Exempt Series of Pool Bonds related thereto) to be an “arbitrage bond” within the meaning of Section 148 of the Code, a “private activity bond” within the meaning of Section 141(a) of the Code, or an obligation the interest on which is subject to federal income taxation because it is “federally guaranteed” as provided in Section 149(b) of the Code. The District, with respect to the proceeds of each Tax-Exempt Series of the Notes (or on any Tax-Exempt Series of Pool Bonds related thereto), will comply with all requirements of such sections of the Code and all regulations of the United States Department of the Treasury issued or applicable thereunder to the extent that such requirements are, at the time, applicable and in effect.

(B) In the event the District is deemed a Safe Harbor Issuer (as defined in Section 7) with respect to a Tax-Exempt Series of Notes (or any Tax-Exempt Series of Pool Bonds related thereto), this subsection (B) shall apply. The District covenants that it shall make all calculations in a reasonable and prudent fashion relating to any rebate of excess investment earnings on the proceeds of each such Tax-Exempt Series of Notes (or such Tax-Exempt Series of Pool Bonds related thereto) due to the United States Treasury, shall segregate and set aside from lawfully available sources the amount such calculations may indicate may be required to be paid to the United States Treasury, and shall otherwise at all times do and perform all acts and things necessary and within its power and authority, including complying with the instructions of Orrick, Herrington & Sutcliffe LLP, Bond Counsel referred to in Section 7 hereof to assure compliance with the Rebate Requirements. If the balance in the Proceeds Subaccount attributed to cash flow borrowing and treated for federal tax purposes as proceeds of the Tax-Exempt Series of Notes (or any Tax-Exempt Series of Pool Bonds related thereto) is not low enough to qualify amounts in the Proceeds Subaccount attributed to cash flow borrowing for an exception to the Rebate Requirements on at least one date within the six-month period following the date of issuance of the Tax-Exempt Series of Notes (or Tax-Exempt Series of Pool Bonds related thereto) (calculated in accordance with Section 7), the District will reasonably and prudently calculate the amount, if any, of investment profits which must be rebated to the United States and will immediately set aside, from revenues attributable to the Fiscal Year 2020-2021 or, to the extent not available from such revenues, from any other moneys lawfully available, the amount of any such rebate in the Rebate Fund referred to in this Section 13(B). In addition, in such event, the District shall establish and maintain with the Trustee a fund (with separate subaccounts therein for each such Tax-Exempt Series of Notes (or such Tax-Exempt Series of Pool Bonds related thereto) if more than one series is issued) separate from any other fund established and maintained hereunder and under the Indenture or Trust Agreement, as applicable, designated as the “2020-2021 Tax and Revenue Anticipation Note Rebate Fund” or such other name as the Trust Agreement or the Indenture, as applicable, may designate. There shall be deposited in such Rebate Fund such amounts as are required to be deposited therein in accordance with the written instructions from Bond Counsel pursuant to Section 7 hereof.

(C) Notwithstanding any other provision of this Resolution to the contrary, upon the District’s failure to observe, or refusal to comply with, the covenants contained in this Section 13,

no one other than the holders or former holders of each Tax-Exempt Series of Notes (or any Tax-Exempt Series of Pool Bonds related thereto), the Certificate or the Bond owners, as applicable, the Credit Provider(s), if any, or the Trustee on their behalf shall be entitled to exercise any right or remedy under this Resolution on the basis of the District's failure to observe, or refusal to comply with, such covenants.

(D) The covenants contained in this Section 13 shall survive the payment of all Series of the Notes.

Section 14. Events of Default and Remedies.

If any of the following events occurs, it is hereby defined as and declared to be and to constitute an "Event of Default":

(A) Failure by the District to make or cause to be made the deposits to any Payment Account required to be made hereunder on or before the fifteenth (15th) day after the date on which such deposit is due and payable, or failure by the District to make or cause to be made any other payment required to be paid hereunder on or before the date on which such payment is due and payable;

(B) Failure by the District to observe and perform any covenant, condition or agreement on its part to be observed or performed under this Resolution, for a period of fifteen (15) days after written notice, specifying such failure and requesting that it be remedied, is given to the District by the Trustee or any Credit Provider, unless the Trustee and such Credit Provider shall all agree in writing to an extension of such time prior to its expiration;

(C) Any warranty, representation or other statement by or on behalf of the District contained in this Resolution or the Certificate Purchase Agreement(s) or the Note Purchase Agreement(s), as applicable (including the Pricing Confirmation(s)), or the Credit Agreement(s) or in any requisition delivered by the District or in any instrument furnished in compliance with or in reference to this Resolution or the Certificate Purchase Agreement(s) or the Note Purchase Agreement(s), as applicable, or the Credit Agreement(s) or in connection with any Series of the Notes, is false or misleading in any material respect;

(D) Any event of default constituting a payment default occurs in connection with any other bonds, notes or other outstanding debt of the District;

(E) A petition is filed against the District under any bankruptcy, reorganization, arrangement, insolvency, readjustment of debt, dissolution or liquidation law of any jurisdiction, whether now or hereafter in effect and is not dismissed within 30 days after such filing, but the Trustee shall have the right to intervene in the proceedings prior to the expiration of such 30 days to protect its and the Certificate or the Bond owners' (or Noteholders') interests;

(F) The District files a petition in voluntary bankruptcy or seeking relief under any provision of any bankruptcy, reorganization, arrangement, insolvency, readjustment of

debt, dissolution or liquidation law of any jurisdiction, whether now or hereafter in effect, or consents to the filing of any petition against it under such law;

(G) The District admits insolvency or bankruptcy or is generally not paying its debts as such debts become due, or becomes insolvent or bankrupt or makes an assignment for the benefit of creditors, or a custodian (including without limitation a receiver, liquidator or trustee) of the District or any of its property is appointed by court order or appointed by the State Superintendent of Public Instruction or takes possession thereof and such order remains in effect or such possession continues for more than 30 days, but the Trustee shall have the right to intervene in the proceedings prior to the expiration of such 30 days to protect its and the Certificate or the Bond owners' or Noteholders' interests; and

(H) An "Event of Default" under the terms of the resolution, if any, of the County providing for the issuance of the Notes (and any Series thereof).

Whenever any Event of Default referred to in this Section 14 shall have happened and be continuing, subject to the provisions of Section 17 hereof, the Trustee shall, in addition to any other remedies provided herein or by law or under the Trust Agreement or the Indenture, as applicable, have the right, at its option without any further demand or notice, to take one or any combination of the following remedial steps:

(1) Without declaring any Series of Notes to be immediately due and payable, require the District to pay to the Trustee, for deposit into the applicable Payment Account(s) of the District under the Trust Agreement or the Indenture, as applicable, an amount equal to all of the principal of all Series of Notes and interest thereon to the respective final maturity(ies) of such Series of Notes, plus all other amounts due hereunder, and upon notice to the District the same shall become immediately due and payable by the District without further notice or demand; and

(2) Take whatever other action at law or in equity (except for acceleration of payment on any Series of Notes) which may appear necessary or desirable to collect the amounts then due and thereafter to become due hereunder or to enforce any other of its rights hereunder.

Notwithstanding the foregoing, and subject to the provisions of Section 17 hereof and to the terms of the Trust Agreement or the Indenture, as applicable, concerning exercise of remedies which shall control if inconsistent with the following, if any Series of Notes is secured in whole or in part by a Credit Instrument or if a Credit Provider is subrogated to rights under any Series of Notes, as long as each such Credit Provider has not failed to comply with its payment obligations under the corresponding Credit Instrument, each such Credit Provider shall have the right to direct the remedies upon any Event of Default hereunder, and as applicable, prior consent shall be required to any remedial action proposed to be taken by the Trustee hereunder, except that nothing contained herein shall affect or impair the right of action of any owner of a Certificate to institute suit directly against the District to enforce payment of the obligations evidenced and represented by such owner's Certificate.

If any Credit Provider is not reimbursed on any interest payment date applicable to the corresponding Series of Notes for the drawing, payment or claim, as applicable, used to pay

principal of and interest on such Series of Notes due to a default in payment on such Series of Notes by the District, as provided in the Trust Agreement or in the Indenture, as applicable, or if any principal of or interest on such Series of Notes remains unpaid after the Maturity Date of such Series of Notes, such Series of Notes shall be a Defaulted Note, the unpaid portion thereof or the portion (including the interest component, if applicable) to which a Credit Instrument applies for which reimbursement on a draw, payment or claim has not been made shall be deemed outstanding and shall bear interest at the Default Rate until the District's obligation on the Defaulted Note is paid in full or payment is duly provided for, all subject to Section 8 hereof.

Section 15. Trustee. The Trustee is hereby appointed as paying agent, registrar and authenticating agent for any and all Series of Notes. The District hereby directs and authorizes the payment by the Trustee of the interest on and principal of any and all Series of Notes when such become due and payable from the corresponding Payment Account held by the Trustee in the name of the District in the manner set forth herein. The District hereby covenants to deposit funds in each such Payment Account at the times and in the amounts specified herein to provide sufficient moneys to pay the principal of and interest on any and all Series of Notes on the day or days on which each such Series matures. Payment of any and all Series of Notes shall be in accordance with the terms of the applicable Series of Notes and this Resolution and any applicable Supplemental Resolution.

The District hereby agrees to maintain the Trustee under the Trust Agreement or the Indenture, as applicable, as paying agent, registrar and authenticating agent of any and all Series of Notes.

The District further agrees to indemnify, to the extent permitted by law and without making any representation as to the enforceability of this covenant, and save the Trustee, its directors, officers, employees and agents harmless against any liabilities which it may incur in the exercise and performance of its powers and duties under the Trust Agreement or the Indenture, as applicable, including but not limited to costs and expenses incurred in defending against any claim or liability, which are not due to its negligence or default.

Section 16. Sale of Notes. If the Certificate Structure is implemented, each Series of Notes as evidenced and represented by the applicable Series of Certificates shall be sold to the Underwriter, in accordance with the terms of the Certificate Purchase Agreement applicable to such Series of Notes, in each case as hereinbefore approved. If the Bond Pool Structure is implemented, each Series of Notes shall be sold to the Authority in accordance with the terms of the Note Purchase Agreement applicable to such Series of Notes, in each case as hereinbefore approved.

Section 17. Subordination. (a) Anything in this Resolution to the contrary notwithstanding, the indebtedness evidenced by each Series of Subordinate Notes shall be subordinated and junior in right of payment, to the extent and in the manner hereinafter set forth, to all principal of, premium, if any, and interest on each Series of Senior Notes and any refinancings, refundings, deferrals, renewals, modifications or extensions thereof.

In the event of (1) any insolvency, bankruptcy, receivership, liquidation, reorganization, readjustment, composition or other similar proceeding relating to the District or its property, (2) any proceeding for the liquidation, dissolution or other winding-up of the District, voluntary or

involuntary, and whether or not involving insolvency or bankruptcy proceedings, (3) any assignment for the benefit of creditors, or (4) any distribution, division, marshalling or application of any of the properties or assets of the District or the proceeds thereof to creditors, voluntary or involuntary, and whether or not involving legal proceedings, then and in any such event, payment shall be made to the parties and in the priority set forth in Section 8(F) hereof, and each party of a higher priority shall first be paid in full before any payment or distribution of any character, whether in cash, securities or other property shall be made in respect of any party of a lower priority.

The subordination provisions of this Section have been entered into for the benefit of the holders of the Series of Senior Notes and any Credit Provider(s) that issues a Credit Instrument with respect to such Series of Senior Notes and, notwithstanding any provision of this Resolution, may not be supplemented, amended or otherwise modified without the written consent of all such holders and Credit Provider(s).

Notwithstanding any other provision of this Resolution, the terms of this Section shall continue to be effective or be reinstated, as the case may be, if at any time any payment of any Series of Senior Notes is rescinded, annulled or must otherwise be returned by any holder of Series of Senior Notes or such holder's representative, upon the insolvency, bankruptcy or reorganization of the District or otherwise, all as though such payment has not been made.

In no event may any holder of all or any part of the Series of Subordinate Notes, or the corresponding Credit Provider(s), exercise any right or remedy available to it on account of any Event of Default on the Series of Subordinate Notes, (1) at any time at which payments with respect thereto may not be made by the District on account of the terms of this Section, or (2) prior to the expiration of forty-five (45) days after the holders of the Series of Subordinate Notes, or the corresponding Credit Provider(s), shall have given notice to the District and to the holders of the Series of Senior Notes and the corresponding Credit Provider(s), of their intention to take such action.

The terms of this Section, the subordination effected hereby and the rights of the holders of the Series of Senior Notes shall not be affected by (a) any amendment of or addition or supplement to any Series of Senior Notes or any instrument or agreement relating thereto, including without limitation, this Resolution, (b) any exercise or non-exercise of any right, power or remedy under or in respect of any Series of Senior Notes or any instrument or agreement relating thereto, or (c) any waiver, consent, release, indulgence, extension, renewal, modification, delay or other action, inaction or omission, in respect of any Series of Senior Notes or any instrument or agreement relating thereto or any security therefor or guaranty thereof, whether or not any holder of any Series of Subordinate Notes shall have had notice or knowledge of any of the foregoing.

In the event that a Series of Additional Subordinate Notes is further subordinated in the applicable Pricing Confirmation, at the time of issuance thereof, to all previously issued Series of Subordinate Notes of the District, the provisions of this Section 17 relating to Series of Senior Notes shall be applicable to such previously issued Series of Subordinate Notes and the provisions of this Section 17 relating to Series of Subordinate Notes shall be applicable to such Series of Additional Subordinate Notes.

Section 18. Continuing Disclosure Undertaking. The provisions of this Section 18 shall be applicable only if the Certificate Structure is implemented; provided, however, in the event the Bond Pool Structure is implemented, the District covenants to report to the Authority and the Trustee the occurrences of the events described in paragraphs (A)(1)j and (A)(2)h, below, within five business days of such occurrence.

(A) The District covenants, for the sole benefit of the owners of each Series of Certificates which evidence and represent the applicable Series of Notes (and, to the extent specified in this Section 18, the beneficial owners thereof), that the District shall:

(1) Provide in a timely manner not later than ten business days after the occurrence of the event, through the Trustee acting as dissemination agent (the “Dissemination Agent”), to the Municipal Securities Rulemaking Board, notice of any of the following events with respect to an outstanding Series of Notes of the District:

- a. Principal and interest payment delinquencies on such Series of Notes and the related Series of Certificates;
- b. Unscheduled draws on debt service reserves reflecting financial difficulties;
- c. Unscheduled draws on credit enhancements reflecting financial difficulties;
- d. Substitution of credit or liquidity providers, or their failure to perform;
- e. Adverse tax opinions or issuance by the Internal Revenue Service of proposed or final determination of taxability or of a Notice of Proposed Issue (IRS Form 5701 TEB);
- f. Tender offers;
- g. Defeasances;
- h. Rating changes; or
- i. Bankruptcy, insolvency, receivership or similar event of the obligated person.

For the purposes of the event identified in subsection i., the event is considered to occur when any of the following occur: the appointment of a receiver, fiscal agent or similar officer for the District in a proceeding under the U.S. Bankruptcy Code or in any other proceeding under state or federal law in which a court or governmental authority has assumed jurisdiction over substantially all of the assets or business of the District, or if such jurisdiction has been assumed by leaving the existing governmental body and officials or officers in possession but subject to the supervision and orders of a court or governmental authority, or the entry of an order confirming a plan of reorganization, arrangement or liquidation by a court or governmental authority having supervision or jurisdiction over substantially all of the assets or business of the District.

- j. Default, event of acceleration, termination event, modification of terms, or other similar events under the terms of a financial obligation of the District, any of which reflect financial difficulties.

(2) Provide in a timely manner not later than ten business days after the occurrence of the event, through the Dissemination Agent, to the Municipal Securities Rulemaking Board, notice of any of the following events with respect to an outstanding Series of Notes of the District, if material:

- a. Unless described in subsection (A)(1)e., other material notices or determinations by the Internal Revenue Service with respect to the tax status of such Series of Notes and the related Series of Certificates or other material events affecting the tax status of such Series of Notes and the related Series of Certificates;
- b. Modifications to rights of owners and beneficial owners of the Series of Certificates which evidence and represent such Series of Notes;
- c. Optional, contingent or unscheduled bond calls;
- d. Release, substitution or sale of property securing repayment of such Series of Notes;
- e. Non-payment related defaults;
- f. The consummation of a merger, consolidation, or acquisition involving the District or the sale of all or substantially all of the assets of the District, other than in the ordinary course of business, the entry into a definitive agreement to undertake such an action or the termination of a definitive agreement relating to any such actions, other than pursuant to its terms;
- g. Appointment of a successor or additional Trustee or the change of name of a Trustee; or
- h. Incurrence of a financial obligation of the District, or agreement to covenants, events of default, remedies, priority rights, or other similar terms of a financial obligation of the District, any of which affect security holders.

For the purposes of the events listed as (1)j. and (2)h., the term “financial obligation” means a (i) debt obligation; (ii) derivative instrument entered into in connection with, or pledged as security or a source of payment for, an existing or planned debt obligation; or (iii) guarantee of (i) or (ii). The term financial obligation shall not include municipal securities as to which a final official statement has been provided to the Municipal Securities Rulemaking Board consistent with the Rule.

Whenever the District obtains knowledge of the occurrence of an event described in subsection (A)(2) of this Section, the District shall determine if such event would be material under applicable federal securities laws. The Authority and the Dissemination Agent shall have no

responsibility for such determination and shall be entitled to conclusively rely upon the District's determination.

If the District learns of the occurrence of an event described in subsection (A)(1) of this Section, or determines that the occurrence of an event described in subsection (A)(2) of this Section would be material under applicable federal securities laws, the District shall within ten business days of occurrence, through the Dissemination Agent, file a notice of such occurrence with the Municipal Securities Rulemaking Board. The District shall promptly provide the Authority and the Dissemination Agent with a notice of such occurrence which the Dissemination Agent agrees to file with the Municipal Securities Rulemaking Board.

All documents provided to the Municipal Securities Rulemaking Board shall be provided in an electronic format, as prescribed by the Municipal Securities Rulemaking Board, and shall be accompanied by identifying information, as prescribed by the Municipal Securities Rulemaking Board.

(B) In the event of a failure of the District to comply with any provision of this Section, any owner or beneficial owner of the related Series of Certificates may take such actions as may be necessary and appropriate, including seeking mandate or specific performance by court order, to cause the District to comply with its obligations under this Section. A default under this Section shall not be deemed an Event of Default under Section 14 hereof, and the sole remedy under this Section in the event of any failure of the District to comply with this Section shall be an action to compel performance.

(C) For the purposes of this Section, a "beneficial owner" shall mean any person which has the power, directly or indirectly, to make investment decisions concerning ownership of any Certificates of the Series which evidences and represents such Series of Notes (including persons holding Certificates through nominees, depositories or other intermediaries and any Credit Provider as a subrogee).

(D) The District's obligations under this Section shall terminate upon the legal defeasance, prior redemption or payment in full of its Note. If such termination occurs prior to the final maturity of the related Series of Certificates, the District shall give notice of such termination in the same manner as for a listed event under subsection (A)(1) of this Section.

(E) The Dissemination Agent shall not be responsible in any manner for the content of any notice or report prepared by the District pursuant to this Section. In no event shall the Dissemination Agent be responsible for preparing any notice or report or for filing any notice or report which it has not received in a timely manner and in a format suitable for reporting. Nothing in this Section shall be deemed to prevent the District from disseminating any other information, using the means of dissemination set forth in this Section or any other means of communication, or including any other notice of occurrence of a listed event under subsection (A)(1) or (A)(2) of this Section (each, a "Listed Event"), in addition to that which is required by this Section. If the District chooses to include any information in any notice of occurrence of a Listed Event in addition to that which is specifically required by this Section, the District shall have no obligation under this Section to update such information or include it in any future notice of occurrence of a Listed Event.

(F) Notwithstanding any other provision of this Resolution, the District with the consent of the Dissemination Agent and notice to the Authority may amend this Section, and any provision of this Section may be waived, provided that the following conditions are satisfied:

(1) If the amendment or waiver relates to the provisions of subsection (A) of this Section, it may only be made in connection with a change in circumstances that arises from a change in legal requirements, change in law, or change in the identity, nature or status of an obligated person with respect to the applicable Series of Notes and the related Series of Certificates, or the type of business conducted;

(2) The undertaking, as amended or taking into account such waiver, would in the opinion of nationally recognized bond counsel, have complied with the requirements of the Rule at the time of the original issuance of the applicable Series of Notes and the related Series of Certificates, after taking into account any amendments or interpretations of the Rule, as well as any change in circumstances; and

(3) The amendment or waiver does not, in the opinion of nationally recognized bond counsel, materially impair the interests of the owners or beneficial owners of the related Certificates. In the event of any amendment or waiver of a provision of this Section, notice of such change shall be given in the same manner as for an event listed under subsection (A)(1) of this Section, and shall include, as applicable, a narrative explanation of the reason for the amendment or waiver; provided, however, the District shall be responsible for preparing such narrative explanation.

(G) The Dissemination Agent shall have only such duties as are specifically set forth in this Section. The Dissemination Agent shall not be liable for the exercise of any of its rights hereunder or for the performance of any of its obligations hereunder or for anything whatsoever hereunder, except only for its own willful misconduct or gross negligence. Absent gross negligence or willful misconduct, the Dissemination Agent shall not be liable for an error of judgment. No provision hereof shall require the Dissemination Agent to expend or risk its own funds or otherwise incur any financial or other liability or risk in the performance of any of its obligations hereunder, or in the exercise of any of its rights hereunder, if such funds or adequate indemnity against such risk or liability is not reasonably assured to it. The District hereby agrees to compensate the Dissemination Agent for its reasonable fees in connection with its services hereunder, but only from the District's share of the costs of issuance deposited in the Costs of Issuance Fund held and invested by the Trustee under the Trust Agreement.

(H) This section shall inure solely to the benefit of the District, the Dissemination Agent, the Underwriter, any Credit Provider and owners and beneficial owners from time to time of the Certificates, and shall create no rights in any other person or entity.

Section 19. Approval of Actions. The aforementioned officers of the County or the District, as applicable, are hereby authorized and directed to execute each Series of Notes and to cause the Trustee to authenticate and accept delivery of each Series of Notes pursuant to the terms and conditions of the applicable Certificate Purchase Agreement and Trust Agreement or the applicable Note Purchase Agreement and the Indenture, as applicable. All actions heretofore taken by the officers and agents of the County, the District or this Board with respect to the sale and issuance of the Notes and participation in the Program are hereby approved, confirmed and ratified and the

officers and agents of the County and the officers of the District are hereby authorized and directed, for and in the name and on behalf of the District, to do any and all things and take any and all actions and execute any and all certificates, requisitions, agreements, notices, consents, and other documents, including tax certificates, letters of representations to the securities depository, investment contracts (or side letters or agreements thereto), other or additional municipal insurance policies or credit enhancements or credit agreements (including mutual insurance agreements) or insurance commitment letters, if any, and closing certificates, which they, or any of them, may deem necessary or advisable in order to consummate the lawful issuance and delivery of each Series of Notes, execution or issuance and delivery of the corresponding Series of Certificates or Series of Pool Bonds, as applicable, and investment of the proceeds thereof, in accordance with, and related transactions contemplated by, this Resolution. The officers of the District referred to above in Section 4 hereof, and the officers of the County referred to above in Section 9 hereof, are hereby designated as "Authorized District Representatives" under the Trust Agreement or the Indenture, as applicable.

In the event that any Series of Notes or a portion thereof is secured by a Credit Instrument, the Authorized Officer is hereby authorized and directed to provide the applicable Credit Provider with any and all information relating to the District as such Credit Provider may reasonably request.

Section 20. Proceedings Constitute Contract. The provisions of each Series of Notes and of this Resolution shall constitute a contract between the District and the registered owner of such Series of Notes, the registered owners of the Series of Certificates or Bonds to which such Series of Notes is assigned, and the corresponding Credit Provider(s), if any, and such provisions shall be enforceable by mandamus or any other appropriate suit, action or proceeding at law or in equity in any court of competent jurisdiction, and shall be irrevocable.

Section 21. Limited Liability. Notwithstanding anything to the contrary contained herein or in any Series of Notes or in any other document mentioned herein or related to any Series of Notes or to any Series of Certificates or Series of Pool Bonds to which such Series of Notes may be assigned, the District shall not have any liability hereunder or by reason hereof or in connection with the transactions contemplated hereby except to the extent payable from moneys available therefor as set forth in Section 8 hereof, and the County is not liable for payment of any Note or any other obligation of the District hereunder.

Section 22. Severability. In the event any provision of this Resolution shall be held invalid or unenforceable by any court of competent jurisdiction, such holding shall not invalidate or render unenforceable any other provision hereof.

Section 23. Submittal of Resolution to County. The Secretary or Clerk of the Board of the District is hereby directed to submit one certified copy each of this Resolution to the Clerk of the Board of Supervisors of the County, to the Treasurer of the County and to the County Superintendent of Schools.

EXHIBIT A
FORM OF NOTE

R-1

\$ _____

_____ DISTRICT/ _____ BOARD OF EDUCATION
COUNTY OF _____, CALIFORNIA

2020-2021 [SUBORDINATE]* TAX AND REVENUE ANTICIPATION NOTE, SERIES __

Date of
Original Issue

REGISTERED OWNER: U.S. BANK NATIONAL ASSOCIATION, AS TRUSTEE SERIES

PRINCIPAL AMOUNT: _____ DOLLARS

Interest Rate

Maturity Date

_____%

_____, 20__

<u>First</u> <u>Repayment Period</u>	<u>Second</u> <u>Repayment Period</u>	<u>Third</u> <u>Repayment Period</u>	<u>Fourth</u> <u>Repayment Period</u>	<u>Fifth</u> <u>Repayment Period</u>
---	--	---	--	---

___% of the total of [principal] [interest] [principal and interest] due at maturity	___% of the total of [principal] [interest] [principal and interest] due at maturity	___% of the total of [principal] [interest] [principal and interest] due at maturity	___% of the total of [principal] [interest] [principal and interest] interest] due at maturity	100% of the total of principal and interest due at maturity**
---	---	---	---	---

FOR VALUE RECEIVED, the District/Board of Education designated above (the "District"), located in the County designated above (the "County"), acknowledges itself indebted to and promises to pay on the maturity date specified above to the registered owner identified above, or registered assigns, the principal amount specified above, together with interest thereon from the date hereof until the principal amount shall have been paid, payable [on _____ 1, 20__ and] on the maturity date specified above in lawful money of the United States of America, at the rate of interest specified above (the "Note Rate"). Principal of and interest on this Note are payable in such coin or currency of the United States as at the time of payment is legal tender for payment of private and public debts, such principal and interest to be paid upon surrender hereof at the principal corporate trust office of U.S. Bank National Association in Los Angeles, California, or its successor in trust (the "Trustee"). Interest shall be calculated on the basis of a 360-day year, consisting of twelve 30-day months, in like lawful money from the date hereof until the maturity date specified above and, if funds are not provided for payment at the maturity, thereafter on the basis of a 360-day year for actual days elapsed until payment in full of said principal sum. Both the principal of and interest on this Note shall be payable only to the registered owner hereof upon surrender of this Note as the same shall fall due; provided, however, no interest shall be payable for any period after maturity during which the holder hereof fails to properly present this Note for payment. If the District fails to pay interest on this Note on any interest

* To bear this designation if this Note is a Series of Subordinate Notes.

**** Length and number of Repayment Periods and percentages and amount of principal of Note shall be determined in Pricing Confirmation (as defined in the Resolution).**

payment date or to pay the principal of or interest on this Note on the maturity date or the [Credit Provider(s)] (as defined in the Resolution hereinafter described), if any, is not reimbursed in full for the amount drawn on or paid pursuant to the [Credit Instrument(s)] (as defined in the Resolution) to pay all or a portion of the principal of and interest on this Note on the date of such payment, this Note shall become a Defaulted Note (as defined and with the consequences set forth in the Resolution).

[It is hereby certified, recited and declared that this Note (the “Note”) represents an authorized issue of the Note in the aggregate principal amount authorized, executed and delivered pursuant to and by authority of a resolution of the governing board of the District duly passed and adopted heretofore, under and by authority of Article 7.6 (commencing with Section 53850) of Chapter 4, Part 1, Division 2, Title 5 of the California Government Code (the “Resolution”), to all of the provisions and limitations of which the owner of this Note, by acceptance hereof, assents and agrees. Pursuant to and as more particularly provided in the Resolution, additional notes may be issued by the District secured by a lien on a parity with the lien securing this Note.]*

[It is hereby certified, recited and declared that this Note (the “Note”) represents an authorized issue of the Note in the aggregate principal amount authorized, executed and delivered pursuant to and by authority of certain resolutions of the governing boards of the District and the County duly passed and adopted heretofore, under and by authority of Article 7.6 (commencing with Section 53850) of Chapter 4, Part 1, Division 2, Title 5 of the California Government Code (collectively, the “Resolution”), to all of the provisions and limitations of which the owner of this Note, by acceptance hereof, assents and agrees. Pursuant to and as more particularly provided in the Resolution, additional notes may be issued by the District secured by a lien on a parity with the lien securing this Note.]**

The term “Unrestricted Revenues” means the taxes, income, revenue, cash receipts and other moneys provided for Fiscal Year 2020-2021 which will be received by or will accrue to the District during such fiscal year for the general fund [and capital fund and/or special revenue fund] of the District and which are lawfully available for the payment of current expenses and other obligations of the District. As security for the payment of the principal of and interest on the Note, subject to the payment priority provisions contained in the Resolution, the District has pledged the first Unrestricted Revenues of the District received in the Repayment Periods set forth on the face hereof in an amount equal to the corresponding percentages of principal of, and [in the final Repayment Period,] interest due on, the Note at maturity set forth on the face hereof (such pledged amounts being hereinafter called the “Pledged Revenues”). As provided in Section 53856 of the California Government Code, subject to the payment priority provisions contained in the Resolution, the Note and the interest thereon shall be a first lien and charge against, and shall be payable from the first moneys received by the District from, the Pledged Revenues. As provided in Section 53857 of the California Government Code, notwithstanding the provisions of Section 53856 of the California Government Code and the foregoing, the Note shall be a general obligation of the District and, in the event that on [the tenth business day of each such Repayment Period],

the District has not received sufficient Unrestricted Revenues to permit the deposit into the payment account established for the Note of the full amount of Pledged Revenues to be deposited

* This paragraph is applicable only if the Note is issued by the District.

** This paragraph is applicable only if the Note is issued by the County.

therein from said Unrestricted Revenues in such Repayment Period as provided in the Resolution, then the amount of any deficiency shall be satisfied and made up from any other moneys of the District lawfully available for the payment of the principal of the Note and the interest thereon, as and when such other moneys are received or are otherwise legally available, as set forth in the Resolution and subject to the payment priority provisions contained therein. The full faith and credit of the District is not pledged to the payment of the principal of or interest on this Note. The County is not liable for payment of this Note.

This Note is transferable, as provided by the Resolution, only upon the books of the District kept at the office of the Trustee, by the registered owner hereof in person or by its duly authorized attorney, upon surrender of this Note for transfer at the office of the Trustee, duly endorsed or accompanied by a written instrument of transfer in form satisfactory to the Trustee duly executed by the registered owner hereof or its duly authorized attorney, and upon payment of any tax, fee or other governmental charge required to be paid with respect to such transfer, a fully registered Note will be issued to the designated transferee or transferees.

The [County, the]* District and the Trustee may deem and treat the registered owner hereof as the absolute owner hereof for the purpose of receiving payment of or on account of principal hereof and interest due hereon and for all other purposes, and [the County,]* the District and the Trustee shall not be affected by any notice to the contrary.

This Note shall not be valid or become obligatory for any purpose until the Certificate of Authentication and Registration hereon shall have been signed by the Trustee.

It is hereby certified that all of the conditions, things and acts required to exist, to have happened and to have been performed precedent to and in the issuance of this Note do exist, have happened and have been performed in due time, form and manner as required by the Constitution and statutes of the State of California and that the amount of this Note, together with all other indebtedness of the District, does not exceed any limit prescribed by the Constitution or statutes of the State of California.

[IN WITNESS WHEREOF, the Board of Supervisors of the County has caused this Note to be executed by the manual or facsimile signature of a duly authorized officer of the County and countersigned by the manual or facsimile signature of its duly authorized officer and caused its official seal to be affixed hereto either manually or by facsimile impression hereon as of the date of authentication set forth below.]*

* Applicable only if the Note is issued by the County.

8.2



Agenda Item Details

Meeting	Oct 21, 2020 - RSD Regular Board Meeting
Category	8. Discussion/Action
Subject	8.2 Considered approval of a Memorandum of Understanding for the Modified Implementation of the Riverpark Joint Use Agreement at Rio Vista Middle and Rio Del Mar Schools during COVID-19 Emergency
Access	Public
Type	Action, Information
Recommended Action	Staff recommends approval of a Memorandum of Understanding for the Modified Implementation of the Riverpark Joint Use Agreement at Rio Vista Middle and Rio Del Mar Schools during COVID-19 Emergency

Public Content

Speaker: Wael Saleh, Assistant Superintendent of Business Services and Dr. Joel Kirschenstein, District Consultant

Rationale:

As the Board is aware, the District has been engaged in on-going discussions with the City of Oxnard to seek to amend the terms of its Joint Use Agreement for the Gymnasium and Community Playfields at Rio Vista Middle and Rio Del Mar Schools. While such effort remains on-going, the City and District have negotiated a Memorandum of Understanding ("MOU") that would temporarily amend the implementation of the Joint Use Agreements for the duration of the COVID-19 Emergency. The terms of the MOU would provide the District with exclusive control of the gymnasium during the COVID-19 Emergency, so that the District may utilize the space for classroom purposes in order to maintain adequate social distancing when schools reopen. The District would be responsible for restoring, at its own expense, the gymnasium to the standard required by the JUA at the conclusion of the emergency. This MOU will extend through the duration of the emergency (with an allowance to continue through the end of the then-current semester at the time), but in any event will expire on June 30, 2021, unless renewed by the District and City.

The MOU is enclosed with this item, and District staff recommends approval of an agreement substantially in the form presented to the Board. Such approval would allow the District to move forward with utilization of the gymnasium space without conflicting with the Joint Use Agreement when the District is able to reopen Rio Vista Middle and Rio Del Mar Schools for in-person classes.

Rio_ Riverpark JUA_ Interim COVID-19 MOU (2).pdf (57 KB)

Administrative Content

Executive Content

**INTERIM MEMORANDUM OF UNDERSTANDING
FOR THE MODIFIED IMPLEMENTATION OF
THE JOINT SCHOOL/PARK USE AGREEMENT FOR THE
MAINTENANCE, OPERATION, AND USE OF THE
SCHOOL AND PARK FACILITIES IN THE RIVER PARK
SPECIFIC PLAN AREA
DURING THE SARS-CoV-2/COVID-19 PANDEMIC**

THIS MEMORANDUM OF UNDERSTANDING (“MOU”) is hereby entered into on this ____ day of September, 2020, by and between the CITY OF OXNARD, a municipal corporation, hereinafter referred to as CITY, and the RIO SCHOOL DISTRICT, a public school district organized and existing under the California Education Code, hereinafter referred to as the DISTRICT. The CITY and DISTRICT may be referred to herein individually as “Party,” or collectively as “Parties.”

RECITALS

A. On or about September 27, 2005, the CITY and DISTRICT entered into a “Joint School/Park Use Agreement for the Maintenance, Operation, and Use of the School and Park Facilities in the River Park Specific Plan Area” (hereinafter, “JUA”) for the joint use of “Gymnasium” and “Community Playfields,” as those terms are defined therein, at Rio Vista Middle School (“RVMS”) and Rio Del Mar School (“RDMS”) located at or near 3050 and 3150 Thames River Drive in the City of Oxnard, California on real property identified as Ventura County Assessor Parcel Nos. 132-0-120-065, 132-0-120-205, 132-0-120-215, 132-0-120-225, and 132-0-120-235 (“JUA Properties”).

B. The JUA was subsequently amended, on or about October 10, 2011, by the “First Amendment to Joint School/Park Use Agreement for the Maintenance, Operation, and Use of the School and Park Facilities in the River Park Specific Plan Area” (hereinafter, “JUA Amendment No. 1”) entered into between the CITY and DISTRICT. For purposes of this MOU, the JUA and JUA Amendment shall hereinafter be referred to collectively as the “JUA.”

C. On March 4, 2020, the Governor of the State of California (“State”) proclaimed a State of Emergency to exist in California as a result of the threat of the SARS-CoV-2/Novel Coronavirus-19 (“COVID-19”) Pandemic (hereinafter also referred to as the “COVID-19 Emergency”).

D. On March 12, 2020, the Ventura County (“County”) Health Officer declared a Local Health Emergency in response to the COVID-19 Pandemic.

E. On March 13, 2020, the CITY proclaimed the existence of a local emergency due to COVID-19.

F. In light of the declared emergencies, and actions taken by State, County, and CITY officials in the intervening months, as well as the DISTRICT, the Ventura County Office of Education (“VCOE”), and the California Department of Education (“CDE”), the CITY and DISTRICT desire to enter into this MOU to temporarily modify the terms of the JUA in order to allow the DISTRICT exclusive use and control of the Gymnasium for the duration of the COVID-19 Emergency, in order to best protect the health, safety, and welfare of the students, teachers, and staff at the RVMS and RDMS. Such allowance shall be subject to the terms and conditions set forth herein. The purpose of such exclusive use would be to allow the DISTRICT to utilize the Gymnasium space for purposes of providing socially distanced classroom, educational, or school-related space, and otherwise clean and sanitize such space in between uses without the concern of outside contamination from other community uses that might otherwise occur under the JUA.

G. This MOU is entered into for the express and sole purpose of facilitating the DISTRICT’s ability to, when permitted by State and County authorities, reopen its schools, inclusive of RVMS and RDMS, in accordance with the best practices and recommendations of CDE and VCOE to best ensure the health and safety of not only the DISTRICT’s students, teachers, and staff, but also the community at-large.

H. This MOU will expire thirty (30) days after the conclusion of the COVID-19 emergency, as determined by the termination of the City’s emergency declaration relating to the COVID-19. The Parties intend to commence discussions in or around January 2021 relative to DISTRICT concerns relative to the overall JUA, but such modifications, if any, will be the subject of a subsequent and formal amendment of the JUA, and shall in no way be affected by this MOU.

AGREEMENT

NOW, THEREFORE, taking the foregoing Recitals in account, which are incorporated herein by this reference, and in consideration of the mutual covenants and conditions set forth herein, and other good and valuable consideration, the receipt and sufficiency of which are hereby acknowledged, the CITY and the DISTRICT do hereby agree as follows:

Section 1. Exclusive District Use and Control of Gymnasium. Notwithstanding the provisions of Sections 6 and 7 of the JUA, as amended by JUA Amendment No. 1, the DISTRICT shall have exclusive use and control of the Gymnasium, 24 hours a day, 7 days a week, for the duration of the COVID-19 emergency as declared by the City. For the duration of this MOU, except as provided herein, scheduling of the Gymnasium by the CITY as contemplated in Section 7 of the JUA shall be suspended, and shall instead be the exclusive responsibility of the DISTRICT.

Section 2. Term. This MOU shall expire, upon its own terms, either (1) the later of 30 days following the rescission of the respective COVID-19 emergency declarations by the City or the end of the then-current school semester; or (2) on June 30, 2021, unless extended by mutual agreement of the Parties. After such time, this MOU shall be of no further force and effect, and the terms of the JUA shall be reinstated in full. After this MOU terminates, the Parties agree that nothing in this MOU shall be used to interpret the provisions of the JUA.

Section 3. Effective Date. This MOU shall take effect immediately upon execution by the City Manager and District Superintendent, based upon emergency powers granted to each by their respective governing bodies.

Section 4. Use of the Gymnasium. It is hereby acknowledged and understood as between the Parties that for purposes of Section 4 of the JUA, the “public education” uses of the Gymnasium permitted for and by the DISTRICT shall include the ability to utilize the Gymnasium for school classroom programs and related purposes.

Section 5. Maintenance (Including Custodial) Responsibilities.

- (a). **Short-Term Regular Maintenance.** Notwithstanding Section 8 of the JUA, as amended by JUA Amendment No. 1, for the duration of this MOU, the DISTRICT shall pay 100% of the cost of providing custodial and cleaning service for the Gymnasium for the duration of this MOU, as well as 100% of the cost of any repairs of facility components damaged or broken during the DISTRICT’s exclusive use of the Gymnasium during the COVID-19 Emergency.
- (b). **Long-Term Maintenance.** With respect to those costs associated with long-term maintenance of the Gymnasium, the District shall be responsible for returning the gymnasium, inclusive of the gym floors, but exclusive of the modifications provided by Section 6, to its pre-COVID condition consistent with the condition required by the JUA, including repairing any damaged caused by the use of the Gymnasium for classroom and/or storage related purposes during the COVID-19 emergency within sixty (60) days of the end of the then-current school semester at the time of the termination or expiration of the MOU, at the District’s sole cost and expense. The District and City, as part of this MOU, shall conduct a post-MOU inspection of the Gymnasium in order to assess and determine those measures necessary to bring the Gymnasium back to its pre-COVID Condition, including, but not limited to, as may be necessary, the cleaning, screening, and recoating of the Gymnasium floor. The provisions of this Section 5(b) shall survive the expiration and/or termination of this MOU.

Section 6. Installation of HVAC Improvements. The CITY agrees and understands that as part of the DISTRICT's use of the Gymnasium for school classroom and related purposes, the DISTRICT may, but is not required to, install heating, ventilation, and/or air conditioning ("HVAC") improvements, which may also include sanitizing elements to combat COVID-19, to the Gymnasium, to improve the suitability of the Gymnasium for classroom use during the COVID-19 Emergency. The CITY shall have no responsibility for such costs of installation of such HVAC improvements, nor shall it share in the costs of maintenance such improvements for the duration of this MOU. If, after the expiration of this MOU, the CITY makes use of the HVAC improvements in the Gymnasium during the times for its own programming, the CITY and DISTRICT shall proportionately share the costs of such future regular maintenance and repair, but in no circumstance will the CITY be responsible for the costs of installation or future replacement of such HVAC improvements unless the Parties reach a future agreement. The provisions of this Section addressing uses of the HVAC improvements after the expiration of this MOU shall survive the expiration or termination of the MOU until such time as an amendment, if any, is approved.

Section 7. Reopener. In the event circumstances change during the duration of the COVID-19 Pandemic and/or this MOU, such that the CITY desires to explore utilization of the Gymnasium for those uses otherwise permitted by the JUA, the City Manager shall contact the District Superintendent, in order to agree to a reasonable amendment to this MOU. In any event, any plan by the CITY to use the Gymnasium facilities during the COVID-19 Emergency shall require the CITY to provide and implement, at its own expense, cleaning protocols after any use reasonably equivalent to those cleaning procedures utilized by the DISTRICT following its classroom uses and/or recommended by CDE in connection with the continued operation of schools during the COVID-19 Pandemic, as such may be amended from time to time. Nothing in this Section 7 shall prevent the CITY and DISTRICT from identifying, if feasible, methods to coordinate cleaning efforts to collectively reduce their costs, provided adequate protocols are in place to ensure the safety of the DISTRICT's students, teachers, and staff within established guidelines. All requests in this Section 7 shall be made in writing, and responded to in writing, by the respective Parties.

Section 8. Community Playfields. Nothing in this MOU shall impact the CITY and DISTRICT's respective uses of and obligations relative to the Community Playfields, as set forth in the JUA.

Section 9. Community Use of Gymnasium. Notwithstanding the provisions contained herein, with respect to the Gymnasium, the CITY may, at its discretion and as an alternative to exercising its options in Section 7, refer any third-party recreational groups desiring to use the Gymnasium during the pendency of this MOU to the DISTRICT, and the DISTRICT may, in its sole discretion, consider whether it can accommodate such use within the safety protocols established for school operations in the Gymnasium. In such case, the CITY

shall have no responsibility for the cleaning or disinfecting of the Gymnasium, nor any liability for the results of such actions by the DISTRICT.

Section 10. Effect of JUA. Except to the extent that the JUA has been expressly modified on a temporary basis by this MOU, the JUA shall remain in full force and effect, without modification or impairment. To the extent any provision of this MOU is in conflict with the JUA, the provisions of this MOU shall control over the conflicting provisions of the JUA for the duration of this MOU. After such time that this this MOU is of no further force and effect, the terms of the JUA shall be reinstated in full.

IN WITNESS WHEREOF, the Parties hereto have executed and delivered this MOU as of the date and year first above written.

CITY OF OXNARD

RIO SCHOOL DISTRICT

By:

Alexander Nguyen
City Manager

By:

Dr. John Puglisi
Superintendent



Agenda Item Details

Meeting	Oct 21, 2020 - RSD Regular Board Meeting
Category	8. Discussion/Action
Subject	8.3 Approval of Resolution 20/21-29 for the Board of Trustee's Resolution of Intent to Consider the Conveyance of a Right-of-way to the City of Oxnard for Public Streets and Public Utility Purposes for the purpose of obtaining permits for Rio Lindo Staff Parking Lot Project.
Access	Public
Type	Action (Consent)
Recommended Action	It is recommended that the Board approve Resolution 20/21-29 for the Conveyance of a Right-of-Way for the purpose of obtaining City permits for the Rio Lindo staff parking lot project.

Public Content

Speaker:

Wael Saleh, Assistant Superintendent, Business Services

Rationale:

Public Content: The City of Oxnard ("City") requires a right-of-way ("Right-of-Way") from the District for public streets and public utility purposes. The Right-of-Way will allow for the City to construct, maintain, and replace, if necessary, a public sidewalk that overlaps onto the District's property, more commonly known as Rio Lindo Elementary School ("Rio Lindo ES").

The District has the authority to grant right-of-ways pursuant to Education Code § 17556 et seq. Before granting a right-of-way under this process, however, the Board must first adopt a "Resolution of Intent" declaring its intention to consider the conveyance of the right-of-way and setting a public hearing at least ten days after the adoption of the Resolution of Intent allowing the public to comment on the proposed conveyance. After holding such hearing, the Board may, unless it receives a written protest signed by at least ten percent of the District's qualified electorate, consider a resolution conveying the requested right-of-way. The hearing must be noticed both through the posting of the Resolution of Intent in at least three public places at least ten days before the hearing, and the publication of notice once in a newspaper of general circulation within the District at least five days before such hearing.

This Resolution sets a public hearing for November 18, 2020, after which the Board may consider a resolution to convey the Right-of-Way.

Both the Resolution of Intent, which is currently before the Board, and the subsequent resolution to convey the Right-of-Way, must be approved **by a vote of at least two-thirds of all the members of the Board.**

The Resolution is enclosed with this item.

Rio Lindo Parking Lot - Resoluton of Intent with Dedication (1).pdf (467 KB)

Administrative Content**Executive Content**

Our adopted rules of Parliamentary Procedure, Robert's Rules, provide for a consent agenda listing several items for approval of the Board by a single motion. Most of the items listed under the consent agenda have gone through Board subcommittee review and recommendation. Documentation concerning these items has been provided to all Board members and the public in advance to assure an extensive and thorough review. Items may be removed from the consent agenda at the request of any board member.

RIO SCHOOL DISTRICT

RESOLUTION #20/21-29

**RESOLUTION OF INTENT TO CONSIDER THE
CONVEYANCE OF A RIGHT-OF-WAY TO THE CITY OF
OXNARD FOR PUBLIC STREETS AND PUBLIC UTILITY
PURPOSES**

WHEREAS, the City of Oxnard (“City”) requires a right-of-way from the Rio School District (“District”) for public streets and public utility purposes;

WHEREAS, the right-of-way sought by the City will allow the City to construct, maintain, and replace, if necessary, a public sidewalk that overlaps onto the District’s property, more commonly known as Rio Lindo Elementary School, located at 2131 Snow Avenue, Oxnard, California 93036 (“Rio Lindo ES”);

WHEREAS, the specific location of the right-of-way is attached hereto as Exhibit “1,” and is incorporated herein by this reference (“City Right-of-Way”);

WHEREAS, the City Right-of-Way is located in an area that will not interfere with the District’s operation of its academic facilities at Rio Lindo ES, or otherwise negatively impact school operation;

WHEREAS, Education Code § 17556 *et seq.* provides the authority for the District to dedicate right-of-way or convey to a public utility an easement on any real property belonging to the District upon such terms and conditions as the parties thereto may agree;

WHEREAS, Education Code § 17557 provides that the Resolution of Intent shall fix a time, not less than ten (10) days thereafter, for a public meeting of the District’s Board of Trustees (“Board”) to be held at its regular place of meeting for a public hearing upon the question of whether to convey the requested City Right-of-Way;

WHEREAS, Education Code § 17558 provides that notice of the adoption of the Resolution of Intent and the public hearing to be held shall be made by (1) posting copies of the Resolution of Intent, signed by the members of the Board or a majority thereof, in three public places in the District for at least ten (10) days before the date of the public meeting, and (2) publishing the notice once at least five (5) days before the date of the meeting in a newspaper of general circulation within the District;

WHEREAS, pursuant to the provisions of Education Code § 17559, unless a protest to the proposed granting of the City Right-of-Way signed by at least ten (10) percent of the qualified electors of the District is entered, the Board may adopt a resolution to grant the proposed City Right-of-Way either at the meeting of the Board at which the public hearing is held or at any other meeting of the Board held within sixty (60) days thereafter;

WHEREAS, the Board desires to convey the City Right-of-Way to the City in a manner substantially similar to that set forth in Exhibit “1,” and generally subject to the terms and conditions set forth therein.

NOW, THEREFORE, be it resolved that:

1. That the above recitals are true and correct, and are incorporated herein by reference.
2. That the Board, in a regular and open meeting, hereby declares its intention to convey the City Right-of-Way as set forth in Exhibit “1.”
3. That in accordance with the provisions of Education Code § 17557, a public hearing on the question of granting the proposed City Right-of-Way shall be held at the public meeting of the Board to be held on November 18, 2020, beginning at 5:00 p.m., or as soon thereafter as the matter may be reasonably heard, at the Conference Room of the District’s Office, 1800 Solar Drive, 3rd Floor, Oxnard, CA 93030. The Superintendent, or Superintendent’s designee, shall specify on the agenda for the November 18, 2020 meeting that the Board shall hold a public hearing on the question of conveying the City Right-of-Way to the City.
4. That in accordance with provisions of Education § 17558, the Superintendent, or the Superintendent’s designee, shall cause notice of the adoption of this Resolution, along with the time and place of the public hearing and meeting to consider the conveyance of the City Right-of-Way, to be given by posting copies of this Resolution, signed by the Board or a majority thereof, in three (3) public places in the District not less than ten (10) days before the date of the meeting, and by publishing the notice once, not less than five (5) days before the date of the meeting in a newspaper of general circulation within the District or County of Ventura, as appropriate.
5. That the Board hereby authorizes the Superintendent, or the Superintendent’s designee, to take such additional action as may be reasonably required to effectuate the intent of this Resolution.

PASSED AND ADOPTED by the Board of Trustees at a regular meeting held on the 21st day of October, 2020, by the following vote:

AYES:

NOES; ABSENT:

ABSTAIN:

Linda Armas,
President of the Board of Trustees

EXHIBIT 1

RECORDING REQUESTED BY AND
WHEN RECORDED MAIL TO:

Oxnard City Clerk's Office
300 West Third Street, 4th Floor
Oxnard, CA 93030

Request recording without fee. Record for the benefit
of City of Oxnard pursuant to Sections 6103 and 27383
of Government Code. No documentary transfer tax
pursuant to R&T Code Section 11922.

(Space above for Recorder's use only.)

County of Ventura
Assessor's Parcel Number: 142-0-111-350
2131 Snow Ave., Oxnard, CA 93036

RIGHT-OF-WAY DEDICATION DEED

FOR VALUABLE CONSIDERATION, receipt of which is acknowledged, the **Rio School District** ("Grantor"), a public school district organized and existing pursuant to the laws of the State of California, hereby dedicates to the **City of Oxnard** ("Grantee") a right-of-way for public streets and public utility purposes over, under, and across the real property described in Exhibits "A" and "B," attached hereto and incorporated by reference herein. This offer of dedication includes the public facilities within the right-of-way constructed for roadway, wastewater, water, storm drain, and/or recycled water purposes.

IN WITNESS WHEREOF, Grantor has caused this instrument to be executed by duly authorized signatories.

Dated: _____, 2020

"GRANTOR"
RIO SCHOOL DISTRICT
a California public school district

By: _____ Dr. John Puglisi, Superintendent

Signatures must be notarized on the following page.

EXHIBIT 1

EXHIBIT "A"

LEGAL DESCRIPTION

That portion of Subdivision No. 26, Rancho el Rio de Santa Clara o'la Colonia, in the City of Oxnard, County of Ventura, State of California, according to that certain Partition Map filed in the office of the County Clerk of said County in that certain action entitled "Thomas A. Scott et al., Plffs. vs. Rafael Gonzales et al. Defts", described as follows:

Beginning at the intersection of the westerly line of Parcel 1, as described in the Final Order of Condemnation filed February 25, 1963, as Instrument No. 10992 in Book 2280, Page 424 of Official Records of Ventura County, with the southerly line of Rio Lindo Street, 60.00 feet wide, said point being the beginning of a curve, concave northerly and having a radius of 280.00 feet, a radial to said point bears South 3°24'31" East; thence along said southerly line of Rio Lindo Street by the following three courses:

- 1st: Easterly along said curve an arc distance of 80.97 feet through a central angle of 16°34'06" to the beginning of a tangent reversing curve, concave southerly and having a radius of 220.00 feet; thence,
- 2nd: Easterly along said curve an arc distance of 76.60 feet through a central angle of 19°56'54", thence tangent to said curve,
- 3rd: North 89°58'18" East 2.12 feet to the beginning of a non-tangent curve, concave southerly and having a radius of 238.90 feet, a radial to said point bears North 4°19'30" West; thence,
- 4th: Westerly along said curve an arc distance of 64.54 feet through a central angle of 15°28'46" to the beginning of a tangent reversing curve, concave northerly and having a radius of 275.80 feet; thence,
- 5th: Westerly along said curve an arc distance of 95.14 feet through a central angle of 19°45'53" to the intersection with the westerly line of said Parcel 1; thence along said westerly line,
- 6th: North 0°02'46" West 0.17 feet to the Point of Beginning of this description.

Containing 426 square feet, more or less.

Larry J. Frager, P.L.S. 7998

Date



EXHIBIT 1

RECORDING REQUESTED BY AND
WHEN RECORDED MAIL TO:

Oxnard City Clerk's Office
300 West Third Street, 4th Floor
Oxnard, CA 93030

Request recording without fee. Record for the benefit
of City of Oxnard pursuant to Sections 6103 and 27383
of Government Code. No documentary transfer tax
pursuant to R&T Code Section 11922.

(Space above for Recorder's use only.)

County of Ventura
Assessor's Parcel Number: 142-0-111-350
2131 Snow Ave., Oxnard, CA 93036

RIGHT-OF-WAY DEDICATION DEED

FOR VALUABLE CONSIDERATION, receipt of which is acknowledged, the **Rio School District** ("Grantor"), a public school district organized and existing pursuant to the laws of the State of California, hereby dedicates to the **City of Oxnard** ("Grantee") a right-of-way for public streets and public utility purposes over, under, and across the real property described in Exhibits "A" and "B," attached hereto and incorporated by reference herein. This offer of dedication includes the public facilities within the right-of-way constructed for roadway, wastewater, water, storm drain, and/or recycled water purposes.

IN WITNESS WHEREOF, Grantor has caused this instrument to be executed by duly authorized signatories.

Dated: _____, 2020

"GRANTOR"
RIO SCHOOL DISTRICT
a California public school district

By: _____ Dr. John Puglisi, Superintendent

EXHIBIT 1

REF: 20054LD1.DWG
DATE: 7/16/2020

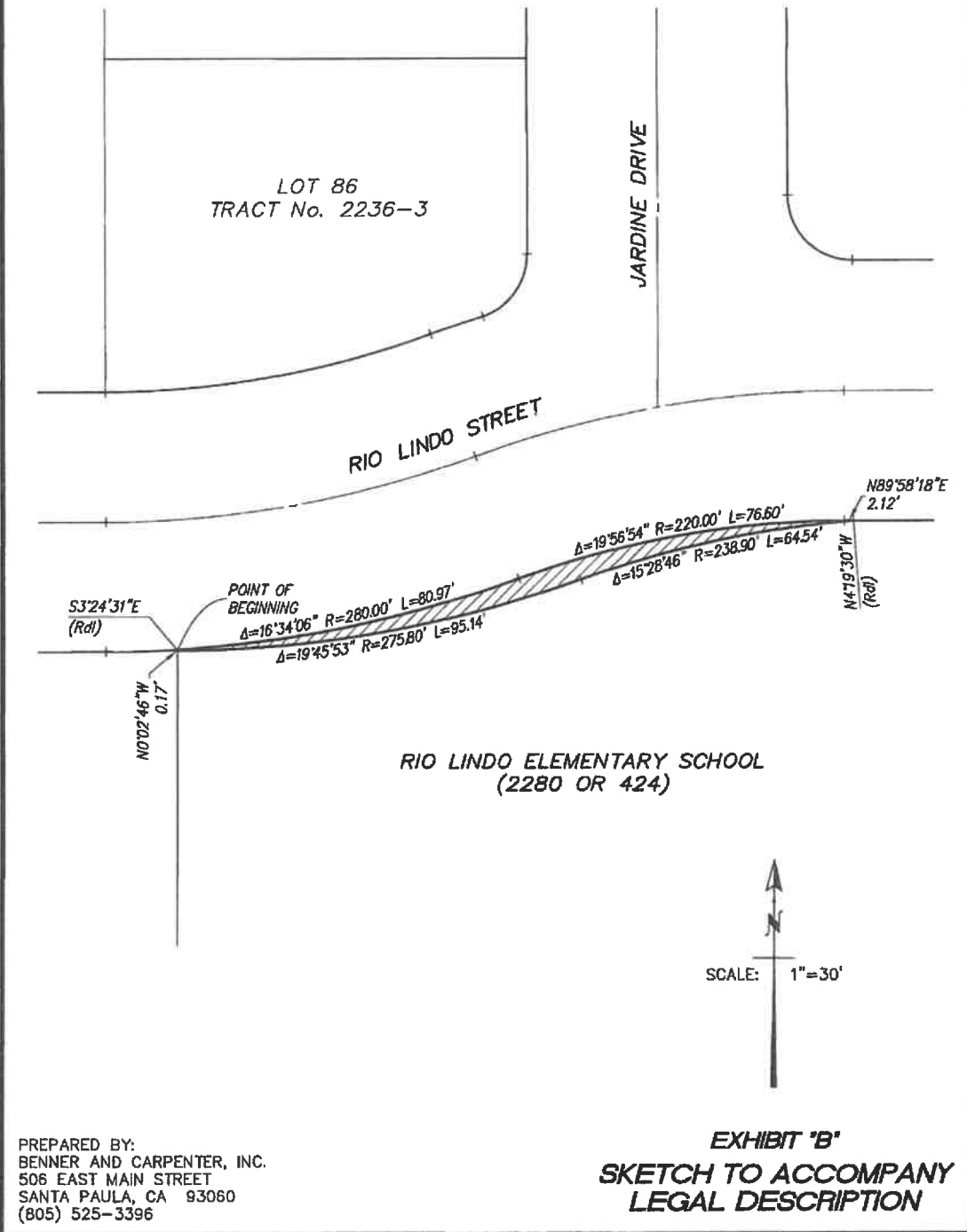
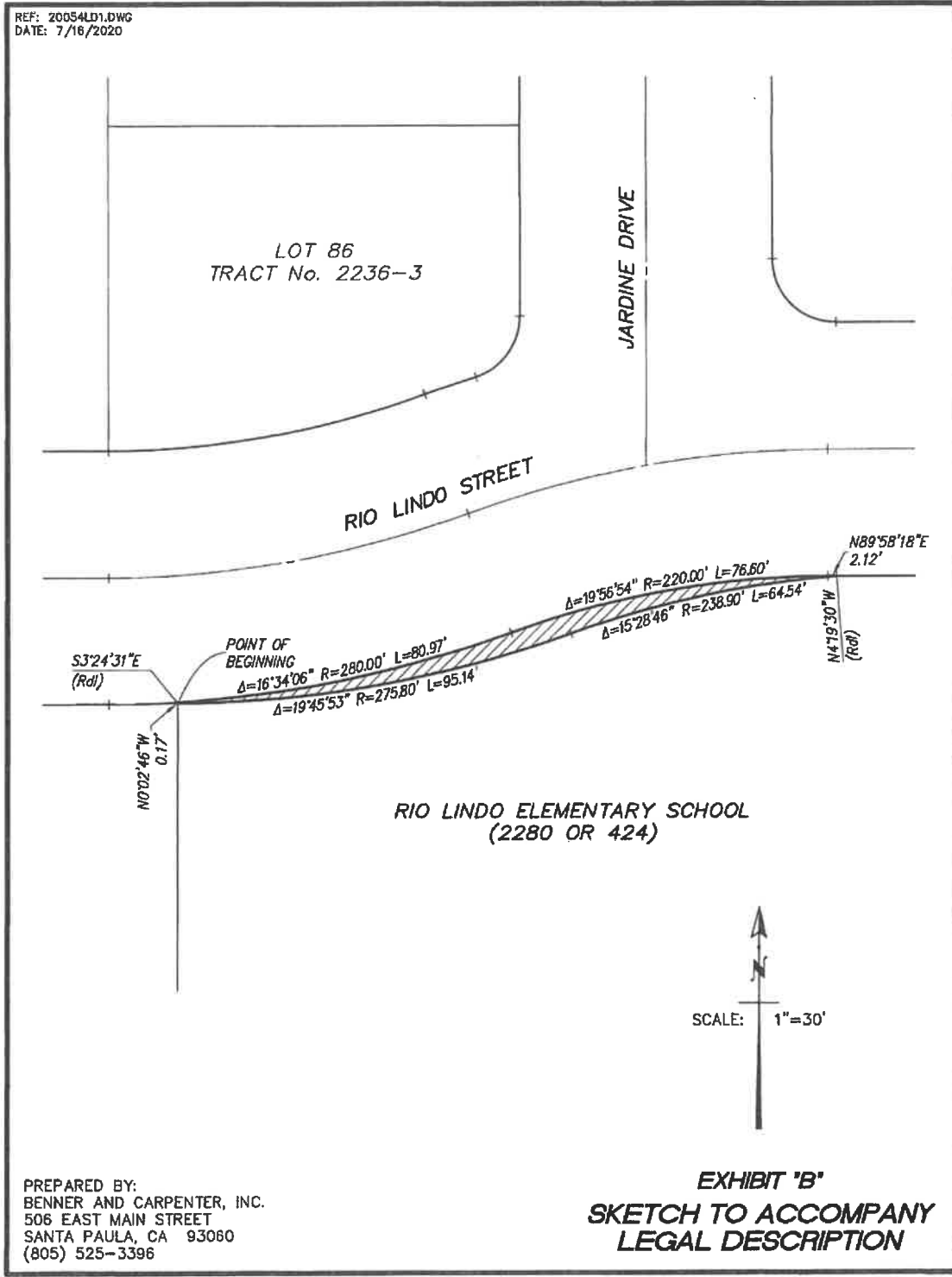

EXHIBIT 1

EXHIBIT 1



A notary public or other officer completing this certificate verifies only the identity of the individual who signed the document to which this certificate is attached, and not the truthfulness, accuracy, or validity of that document.

EXHIBIT 1

EXHIBIT 1

STATE OF CALIFORNIA)
) COUNTY OF _____)

On _____, 20__ before me, _____, Notary Public, personally appeared _____, who proved to me on the basis of satisfactory evidence to be the person(s) whose name(s) is/are subscribed to the within instrument and acknowledged to me that he/she/they executed the same in his/her/their authorized capacity(ies), and that by his/her/their signature(s) on the instrument the person(s), or the entity upon behalf of which the person(s) acted, executed the instrument.

I certify under PENALTY OF PERJURY under the laws of the State of California that the foregoing paragraph is true and correct.

WITNESS my hand and official seal.

Notary Public Signature

Notary Public Seal

CERTIFICATE OF ACCEPTANCE

This is to certify that the interests in real property conveyed by this deed or grant, dated _____, from the RIO SCHOOL DISTRICT, a California public school district, to the CITY OF OXNARD, a California general law city, is hereby accepted by the undersigned officer or agent on behalf of the City Council of the City of Oxnard, pursuant to authority conferred by Resolution No. ____ adopted by said Council on _____, 20__, and the grantee consents to recording hereof by the undersigned, duly authorized officer.

By: _____

Name: _____

Its: _____

8.4



Agenda Item Details

Meeting	Oct 21, 2020 - RSD Regular Board Meeting
Category	8. Discussion/Action
Subject	8.4 Approval of Resolution 2021/30 Authorizing Emergency Improvement Work Related to Increasing COVID 19 Safety at All District School Sites
Access	Public
Type	Action
Recommended Action	Staff recommends approval of Resolution 20/21-30 Authorizing Emergency Improvement Work Related to Increasing COVID 19 Safety at All District School Sites

Public Content

Speaker: Wael Saleh, Assistant Superintendent of Business Services

Rationale:

In March 2020, it was necessary to close all schools to combat the spread of COVID-19. Since this time, Health Experts have learned a great deal about the virus and how it transmits; specifically, through the air.

As a result of the potential transmission of the virus through the air, Health Experts have determined that classrooms must have adequate fresh air ventilation to reduce the transmission of the virus. In order to reduce the transmission of the virus it is vital the District take immediate actions as a result of this emergency to make improvements to the ventilation of each classroom in the district. The attached Emergency Improvement Resolution would authorize the District to take necessary steps to reduce the transmission of the virus by making Emergency Improvements immediately by waiving the bidding requirements set forth in the Public Contract Code. The waiver of the bidding requirements is necessary to protect the safety of students and staff in order to reopen schools on November 30, 2020.

With Rio Schools set to begin reopening on November 30, 2020; it is imperative to the safety of students and all staff that each classroom is well-ventilated in order to minimize the spread of the virus which causes COVID-19.

There will be no impact to the District's General Fund. The District's costs will be funded out of dedicated facilities bond and related mitigation fee funds.

Emergency Resolution - Air Purification.pages (864 KB)

Administrative Content

Executive Content

**RIO SCHOOL DISTRICT
BOARD OF EDUCATION**

**RESOLUTION 2021/30
AUTHORIZING EMERGENCY IMPROVEMENT WORK RELATED TO
INCREASING COVID 19 SAFETY AT ALL SCHOOLS**

WHEREAS, on March 4, 2020, the Governor of California declared a State of Emergency due to the outbreak and spread of the COVID-19 virus;

WHEREAS, on March 11, 2020, the World Health Organization declared the COVID-19 virus a world-wide Pandemic;

WHEREAS, on March 16, 2020, the Governor of California issued Executive Order N- 26-20

WHEREAS, the District's Board of Education, Superintendent are committed to ensuring the health and safety of its students, staff and families;

WHEREAS, it is imperative to take proactive measure to prepare for and implement actions to respond to, and minimize, the potential spread of COVID-19 in the Rio School District (District) schools;

WHEREAS, it is imperative to have the tools to ensure the health and safety of students, staff, and families on our campuses;

WHEREAS, certain laws, regulations, and policies interfere with the District's ability to provide the immediate action required to address these critical health and safety concerns;

WHEREAS, the protection of the health and safety and preservation of the lives of students, staff and families, from the effects of natural emergencies such as virulent infectious diseases like COVID-19, which may cause extreme peril to life, property, and resources is of paramount local and State importance requiring the responsible efforts of public and private agencies and individual citizens;

WHEREAS, under California Public Contract Code Section 20113, in an emergency when any repairs, alterations, work, or improvement is necessary to any facility of public schools to permit the continuance of existing school classes, or to avoid danger to life or property, the board may, by a unanimous vote of the district's Board of Trustees declaring that an emergency exists and with the approval of the county superintendent of schools; do the following: make a contract in writing or otherwise on behalf the district for the performance of labor and furnishing of materials or supplies for the purpose without advertising for or inviting bid, notwithstanding section 20114;

WHEREAS, Public Contract Code section 1102 defines an emergency as a sudden, unexpected occurrence that poses a clear and imminent danger, requiring immediate action to prevent or mitigate the loss or impairment of life, health, property or essential public services;

WHEREAS, science has determined that the virus which causes COVID-19 can float in the air, and linger in poorly ventilated indoor spaces, potentially spreading farther than 6 feet from its source;

WHEREAS, providing safe classrooms and common areas require the air to be well-ventilated, and the proper refiltration of air in order to remove potential COVID-19 droplets from the classrooms and all other school buildings is a matter that poses a clear and imminent danger to students and all staff, requiring immediate action, where failure to do so impairs the district's ability to provide well-ventilated air to all indoor facilities in every school, constituting an emergency, as defined by the public contract code;

WHEREAS, the District is set to re-open schools on November 30, 2020 and remedying this emergency should not permit a delay resulting from a competitive solicitation for bids to perform the required repair work, and immediate action is necessary to respond to the emergency; and

WHEREAS, facts exist and are rapidly emerging that installing air purification units in each classroom is required to maintain a well-ventilated area increasing the safety of its schools because of the COVID-19 epidemic; and

WHEREAS, generally, Public Contract Code section 22030 et seq. requires a school district that has opted to comply with the California Uniform Public Construction Cost Accounting Act (Public Contract Code § 22000 et seq.) (the "Act") to informally bid any contract for construction work exceeding \$60,000 in value and to formally bid any contract for construction work exceeding \$200,000 in value; and

WHEREAS, the District has elected to comply with the provisions of the Act; and

WHEREAS, the Act provides that in cases of emergency when repair or replacements are necessary, the District Board may proceed at once to repair or replace any public facility without adopting plans, specifications, strain sheets, or working details, or give notice for bids or to let contracts, and may proceed by day labor or by contractor, or a combination of the two. (Public Contract Code §22035). Similarly, Public Contract Code §20113, authorizes a school district when faced with an emergency and to avoid danger to life or property to proceed with the performance of labor and furnishing of materials by day labor or force account to address and repair the conditions of the emergency; and

WHEREAS, the Act provides further that emergency work under Public Contract Code §22035 must be done pursuant to the terms of Public Contract Code § 22050; and

WHEREAS, Public Contract Code § 22050 requires the following steps be taken:

1. Pursuant to a four-fifths (4/5) vote of the Board, the District may repair or replace a public facility, take any directly related and immediate action required by that emergency, and procure the necessary equipment, services, and supplies for those purposes, without giving notice for bids to let contracts; and
2. Before taking any action pursuant to paragraph (1), the Board shall make a finding, based on substantial evidence set forth in the minutes of its meeting, that the emergency will not permit a delay resulting from a competitive solicitation for bids, and that the action is necessary to respond to the emergency; and

3. The Board, by a four-fifths (4/5) vote, may delegate the District Superintendent and/or designee, the authority to order any action pursuant to paragraph (1); and
4. If a person with authority delegated pursuant to paragraph (3) orders any action specified in paragraph (1), that person shall report to the Board, at its next meeting required pursuant to this section, the reasons justifying why the emergency will not permit a delay resulting from a competitive solicitation for bids and why the action is necessary to respond to the emergency; and
5. If the Board orders any action specified above, the Board shall review the emergency action at its next regularly scheduled meeting and, except as specified below, at every regularly scheduled meeting thereafter until the action is terminated, to determine, by a four-fifths (4/5) vote, that there is a need to continue the action. If the Board meets weekly, it may review the emergency action in accordance with this paragraph every 14 day; and
6. If a person with delegated authority orders any action specified in paragraph (1), the Board shall initially review the emergency action not later than 7 days after the action, or at its next regularly scheduled meeting if that meeting will occur not later than 14 days after the action, and at least at every regularly scheduled meeting thereafter until the action is terminated, to determine, by a four-fifths (4/5) vote, that there is a need to continue the action, unless a person with delegated authority has terminated that action prior to the Board reviewing the emergency action and making a determination pursuant to this subdivision. If the Board meets weekly, it may, after the initial review, review the emergency action in accordance with this paragraph every 14 days; and
7. When the Board reviews the emergency action, it shall terminate the action at the earliest possible date that conditions warrant so that the remainder of the emergency action may be completed by giving notice for bids to let contracts; and

WHEREAS, immediate action must be taken by the District at each School site in Rio, including, without limitation, the following Emergency Improvements:

- (1) Taking all actions required to make each indoor space in the District safe and secure to prevent and minimize any possible public health issues;
- (2) Procuring and/or performing other associated services and public works required to resume the use of classrooms compliance with County Health orders;

WHEREAS, because of the requirement that Emergency Improvements be done without delay, District staff must direct firms to perform the Emergency Improvements related to the emergency without following formal bidding practices.

NOW, THEREFORE, the Governing Board of the Rio School District hereby finds, determines, declares, orders and resolves as follows:

1. That the above recitals are true and correct; and
2. That the circumstances described in the Resolution herein that constitute an emergency condition as defined by applicable statute(s); and

3. That circumstances of the Emergency necessitate that the work related to the Emergency be let without a competitive solicitation for bids to respond to the Emergency; and
4. That based on the foregoing, it would be incongruous, futile and unavailing to attempt to bid this work; and
5. That by at least a 4/5 vote pursuant to section 20113 of the Public Contract Code authorizes the execution of contracts without advertising or inviting bids; and, notwithstanding section 20114, authorizes the flexibility of M & O, notwithstanding section 20114, to respond to the emergency conditions at District Sites; and
6. Delegates to the RSD Superintendent or his designee, to seek approval of the Superintendent of Schools in Ventura County, pursuant to Board Policy 2210 and further to its broad authority under Education Code section 35160, the authority to act on behalf of the Board of Education and the District in manners that are consistent with law and Board policies; and
7. That District staff report on the status of this Emergency to the District's Governing Board at the Board's next regularly scheduled Board meeting and at all subsequent regularly scheduled Board meetings until the Board terminates the Emergency action.
8. That, to the extent actions in point 6 have been undertaken by the District's Superintendent or designee, the Board hereby ratifies such actions in response to the Emergency.

APPROVED, PASSED AND ADOPTED at a meeting of the Board of Education of the Rio School District held on the ____ day of October 2020.

AYES:

NOES:

ABSENT:

ABSTAIN:

STATE OF CALIFORNIA
COUNTY OF VENTURA

I, _____ of the Governing Board of the Rio School District of Ventura County, California, do hereby certify that the foregoing is a full, true, and correct copy of a resolution adopted by the said Board at a regular Meeting thereof held at its regular place of meeting at the time and by the vote above stated, which resolution is on file in the office of the said Board.

Board President



Agenda Item Details

Meeting	Oct 21, 2020 - RSD Regular Board Meeting
Category	9. Consent
Subject	9.2 Approval of the Minutes of the Regular Board Meeting of September 16, 2020
Access	Public
Type	Action (Consent), Minutes
Recommended Action	Staff recommends approval.
Minutes	View Minutes for Sep 16, 2020 - RSD Regular Board Meeting

Public Content

Speaker:

Rationale:

Min091620.pdf (62 KB)

Administrative Content

Executive Content

Our adopted rules of Parliamentary Procedure, Robert's Rules, provide for a consent agenda listing several items for approval of the Board by a single motion. Most of the items listed under the consent agenda have gone through Board subcommittee review and recommendation. Documentation concerning these items has been provided to all Board members and the public in advance to assure an extensive and thorough review. Items may be removed from the consent agenda at the request of any board member.



**Rio School District
Minutes
Regular Board Meeting
September 16, 2020
Rio School District
1800 Solar Drive
Oxnard, CA 93030
Closed Session: 5:00 p.m.
Open Session: 6:00 p.m.**

Members present

Eleanor Torres, Edith Martinez-Cortes, Felix Eisenhauer, Linda Armas, Joe Esquivel

1. Open Session 5:00 p.m.

1.1 Call to Order

President Armas convened the meeting at 5:01 p.m.

1.2 Pledge of Allegiance

President Armas led the pledge of allegiance.

1.3 Roll Call

Trustee Torres called the roll, all present

2. Approval of the Agenda

2.1 Agenda Correction, Additions, Modifications

The following items were tabled by President Armas, Item 10.2 Approval of the Contract with Diane DeLaurentis to Provide Performing Arts Services FY 2020/2021. Trustee Esquivel tabled item 11.25 Ratification of Notice of Award for Reed Mechanical, Project No. 20-17L for Rio Vista Middle School and Rio del Mar Elementary, Trustee Esquivel also pulled for discussion/action Items 11.7 Local Agency Biennial Notice for 2020 and 11.8 Adoption of the GANN Limit/Resolution No. 20/21-12. Trustee Torres pulled Item 11.4 Ratification of the Commercial Warrant Register for August 10, 2020 throughout September 2, 2020.

2.2 Approval of the Agenda

Staff recommends approval as amended

Motion by Joe Esquivel, second by Eleanor Torres.

Final Resolution: Motion Carries

Yes: Eleanor Torres, Edith Martinez-Cortes, Felix Eisenhauer, Linda Armas, Joe Esquivel

3. Public Comment-Closed Session

3.1 Public Comment (Closed Session) The public may address the Board concerning items that are scheduled for discussion during the closed session only. These presentations are limited to three minutes each, or a total of fifteen minutes in all.

There were no public comments regarding closed session.

President Armas adjourned the meeting into closed session at 5:06 p.m.

4. Closed Session

4.1 Public Employee Discipline/Dismissal/Release

4.2 Conference with Labor Negotiators [Government Code 54957.6] Agency designated representatives: RSD Negotiating Team; Employee Organization: California School Employee's Association and Rio Teachers' Association

4.3 Public Employee Performance Evaluation [Government Code 54957] Title: Staffing 2020/21

5. Reconvene Open Session 6:00 p.m.

5.1 Report of Closed Session

President Armas reconvened the meeting at 6:38 p.m. No action was taken and the Governing Board will reconvene into closed session at the end of the meeting.

6. Public Hearing

6.1 Public Hearing of Resolution #2021/01 Sufficiency of Instructional Materials
President Armas opened the public hearing at 6:39 p.m. in regards to Resolution 2021/01 Sufficiency of Instructional Materials. As there were no comments, President Armas closed the public hearing at 6:39 p.m.

6.2 Public Hearing for Learning Continuity Plan (LCP)

President Armas opened the public hearing at 6:39 p.m. in regards to the Learning Continuity Plan. As there were no public comments, President Armas closed the public hearing at 6:40 p.m.

7. Presentations/Recognitions

7.1 Rio Real Dual Immersion AP Spanish Student Recognition

Oscar Hernandez, Assistant Superintendent of Educational Services, presented information in regards to the Rio Real Dual Immersion AP Spanish students. Dr. Maria Hernandez, Principal, introduced the students that took the AP exam.

8. Communications

8.1 Acknowledgement of Correspondence to the Board

President Armas stated that written correspondence has been received by members of the public and has been shared with the other board members.

8.2 Board Member Reports

Board member reports were heard from Trustee Esquivel and Eisenhauer.

8.3 Organizational Reports-RTA/CSEA/Other

Organizational reports were heard from Marisela Valdez, President of Rio Teachers' Association and Patrick Radford, Vice-President of CSEA.

8.4 Superintendent Report

Superintendent Puglisi presented information on enrollment for the first 10 days of school and the percentage of students that attended online daily. Additionally, site principals also commented on the opening of the school year.

8.5 Public Comment-Board meetings are meetings of the Governing Board held in public, not public forums, and will be held in a civil, orderly and respectful manner. All public comments or questions should be addressed to the board through the board president. To assure an orderly meeting and an equal opportunity for each speaker, persons wishing to address the Board must fill out a speaker card. Cards are available at the meeting and on the District website. Cards must be submitted to the Secretary or Clerk of the Board. The speaker may choose to speak during public comment or at the time of the agenda item prior to board consideration. The Governing Board may place limitations on the total time to be devoted to each topic if it finds that the number of speakers would impede the Board's ability to conduct its business in a timely manner. Procedures for receiving communication from the public on topics that fall under the subject jurisdiction of the Governing Board. A member of the public may address the Governing Board on any item(s) on the agenda or non-agenda items. Each person speaking may not exceed a total of three minutes on each item. The speaker may choose to speak during public comment or at the time of the agenda item prior to board consideration. These presentations are limited to three minutes or a total of twenty minutes. Public comment was heard from Stephanie Towner.

9. Information

9.1 Business Services Report

Wael Saleh, Assistant Superintendent of Business Services, presented the Facilities update.

9.2 Educational Services Report

Oscar Hernandez, Assistant Superintendent of Educational Services, presented his report on the Rio Plaza Dual Immersion Program. Ms Brenda Bravo also commented on the program.

9.3 School and Systems Improvement Report

Dr. Carolyn Bernal, Assistant Superintendent of School and Systems Improvement, provided a COVID 19 Operational Report. Mr. Saleh also had some input regarding the disinfecting procedures.

10. Discussion/Action

10.1 Adoption of Resolution #2021/01 and Certification Sufficiency of Instructional Materials

Staff recommends board approval of Resolution #2021/01 Sufficiency of Instructional Materials.

Motion by Felix Eisenhauer, second by Joe Esquivel.

Final Resolution: Motion Carries

Yes: Eleanor Torres, Edith Martinez-Cortes, Felix Eisenhauer, Linda Armas, Joe Esquivel

10.2 Approval of the Contract with Diane DeLaurentis to Provide Performing Arts Services FY 2020/2021

This item has been tabled to September 30, 2020.

10.3 Replacement and upgrade of the marquee signs and the sign management system at five school signs

Staff recommends replacing and upgrading the marquee signs and the sign management systems

Motion by Eleanor Torres, second by Felix Eisenhauer.

Final Resolution: Motion Carries

Yes: Eleanor Torres, Edith Martinez-Cortes, Felix Eisenhauer, Linda Armas, Joe Esquivel

10.4 Consideration for Approval of Resolution 20/21-15 for the Amended Authorization for the Public Sale, Lease, or Exchange of 2715 East Vineyard Avenue Property

Staff recommends approval

Motion by Eleanor Torres, second by Felix Eisenhauer.

Final Resolution: Motion Carries

Yes: Eleanor Torres, Edith Martinez-Cortes, Felix Eisenhauer, Linda Armas, Joe Esquivel

10.5 Approval of the Unaudited Actuals for 2019/2020

It is recommended that the Unaudited Actuals be approved.

Motion by Eleanor Torres, second by Felix Eisenhauer.

Final Resolution: Motion Carries

Yes: Eleanor Torres, Edith Martinez-Cortes, Felix Eisenhauer, Linda Armas, Joe Esquivel

11. Consent

11.1 Approval of Consent Agenda

It is recommended that the Board approve the Consent Agenda, as amended.

Motion by Eleanor Torres, second by Felix Eisenhauer.

Final Resolution: Motion Carries

Yes: Eleanor Torres, Edith Martinez-Cortes, Felix Eisenhauer, Linda Armas, Joe Esquivel

11.2 Approval of the Minutes of the Regular Board Meeting of August 19, 2020

11.3 Approval of the Minutes of the Special Board Meeting of August 26, 2020

11.4 Ratification of the Commercial Warrant for August 10, 2020, through September 2, 2020.

It is recommended that the Commercial Warrant be approved for the period August 10, 2020 through September 2, 2020.

Motion by Eleanor Torres, second by Felix Eisenhauer.

Final Resolution: Motion Carries

Yes: Eleanor Torres, Edith Martinez-Cortes, Felix Eisenhauer, Linda Armas, Joe Esquivel

11.5 September 2020 Personnel Report

11.6 Contract for Speech Pathologist Services

11.7 Local Agency Biennial Notice for 2020

It is recommended that the Board approve the 2020 Local Agency Biennial Notice.

Motion by Joe Esquivel, second by Felix Eisenhauer.

Final Resolution: Motion Carries

Yes: Eleanor Torres, Edith Martinez-Cortes, Felix Eisenhauer, Linda Armas, Joe Esquivel

11.8 Adoption of the GANN Limit/Resolution No. 20/21-12

Staff recommends approval of the GANN Limit Resolution

Motion by Joe Esquivel, second by Felix Eisenhauer.

Final Resolution: Motion Carries

Yes: Eleanor Torres, Edith Martinez-Cortes, Felix Eisenhauer, Linda Armas, Joe Esquivel

11.9 Approval of a 6 month contract for 800 Kajeet hotspots

11.10 Approval of 300 Google Voice phone service licenses for teachers and staff

11.11 Ratification Of Approval of Change Order #1 from Venco Electric Project #20-02L, for the New Campus Fire Alarm System at Rio Lindo Elementary School

11.12 Ratification of Approval of Change Order from Civic Construction to capture all rainwater in the Rio Lindo Elementary School parking lot

11.13 Ratification of Approval of Change Order from Channel Islands Roofing for 20-24L at Rio del Valle Middle School

11.14 Ratification of Approval of Change Order from ACH Mechanical Contractors, Inc. for addition to HVAC at Rio Del Sol STEAM School

11.15 Ratification of Approval of CREDIT Change Order from MM Mechanical for plumbing fixtures at Rio Del School STEAM School

11.16 Notice of Completion and Resolution No. 20/21-06 for Reed Mechanical, Inc. for A/C at Rio Lindo Elementary School

11.17 Resolution No. 20/21-05, Notice of Completion for Venco Electric, Project 20-02L Campus wide fire alarm at Rio Lindo Elementary School

11.18 Resolution 20/21-13 for Notice of Completion for Benner & Carpenter, Inc. at Rio del Sol STEAM School

11.19 Notice of Completion and Resolution 20/21-09 for MM Mechanical Project No. 20-23L at the District Office

11.20 Notice of Completion and Resolution for Finish Line Paving for Rio Del Sol storage area.

11.21 Notice of Completion and Resolution No. 20/21-07 for MM Mechanical at Rio del Sol STEAM School

Resolution: It is recommended that the Board approve the Resolution for the Completion of

11.23 Notice of Completion and Resolution No. 20-21/08 for Got Shade Shade Sails for Outdoor Classroom at Rio Rosales Elementary School

11.24 Approval of Notice of Completion and Resolution 20/21-14 for Project No. 20-09L, touchless fixtures at Rio Lindo Elementary School

11.25 Ratification of Notice of Award for Reed Mechanical, Project No. 20-17L for Rio Vista Middle School and Rio del Mar Elementary School.

This item was tabled.

11.26 Ratification of Notice of Award for Kiwitt General Contractor for Project 20-25L for Rio Rosales Elementary School

Resolution: It is recommended that the Ratification of the Notice of Award to Kiwitt General

12. Organizational Business

12.1 Future Items for Discussion

The Governing Board reconvened into closed session at 9:53 p.m.

President Armas reconvened the meeting at 10:22 p.m.

President Armas reported no action took place during closed session.

Future items include a report of costs to run the gym, and a sufficiency of textbook presentation, a tech report on computers and hotspots.

12.2 Future Meeting Dates: September 30, 2020 at 5:00 p.m. and October 21, 2020 at 5:00 p.m.

13. Adjournment

President Armas adjourned the meeting at 10:25 p.m.

Approved on this 21st day of August, 2020.

John Puglisi, Ph.D., Secretary

Date

Eleanor Torres, Clerk of the Board

Date



Agenda Item Details

Meeting	Oct 21, 2020 - RSD Regular Board Meeting
Category	9. Consent
Subject	9.3 Approval of the Minutes of the Special Board Meeting of September 30, 2020
Access	Public
Type	Action (Consent), Minutes
Minutes	View Minutes for Sep 30, 2020 - Rio School District Special Board Meeting

Public Content

Speaker:

Rationale:

SpecMin093020.pdf (66 KB)

Administrative Content

Executive Content

Our adopted rules of Parliamentary Procedure, Robert's Rules, provide for a consent agenda listing several items for approval of the Board by a single motion. Most of the items listed under the consent agenda have gone through Board subcommittee review and recommendation. Documentation concerning these items has been provided to all Board members and the public in advance to assure an extensive and thorough review. Items may be removed from the consent agenda at the request of any board member.



EDUCATING LEARNERS FOR THE 21ST CENTURY

Special Board Meeting
September 30, 2020
Open Session 5:00 p.m.
Closed Session 6:00 p.m.
1800 Solar Drive
Oxnard, CA 93036

Members present

Eleanor Torres, Edith Martinez-Cortes, Felix Eisenhauer, Linda Armas, Joe Esquivel

1. Preliminary Business

1.1 Call to Order-5:00 p.m

President Armas opened the meeting at 5:01 p.m.

1.2 Pledge of Allegiance

President Armas led the flag salute.

1.3 Roll Call

Trustee Torres called the roll, all present.

2. Approval of the Agenda

2.1 Agenda corrections, additions, and modifications.

There were no modifications or corrections to the agenda.

2.2 Approval of the Agenda

Staff recommends approval of the agenda as presented.

Motion by Eleanor Torres, second by Felix Eisenhauer.

Final Resolution: Motion Carries

Yes: Eleanor Torres, Edith Martinez-Cortes, Felix Eisenhauer, Linda Armas, Joe Esquivel

3. Open Session 5:00

3.1 Public Comment Procedures for receiving communication from the public on topics that fall under the subject jurisdiction of the Governing Board. 1. Special Board Meeting - A member of the public may address the Governing Board on any item(s) on the agenda. (Each person speaking may not exceed a total of three minutes on each item). The speaker may choose to speak during public comment or at the time of the agenda item prior to board consideration. These presentations are limited to three minutes or a total of twenty minutes.

Public comments were heard from Courtney Burke, David Romano, Mary Walzer, Marisela Valdez, Rizza Husband, Barbra Beltran Walker, and Cassandra Bautista.

4. Information/Action

4.1 Approval of the Learning Continuity Plan (LCP)

Staff recommends approval of the Learning Continuity Plan.

Motion by Eleanor Torres, second by Felix Eisenhauer.

Final Resolution: Motion Carries

Yes: Eleanor Torres, Edith Martinez-Cortes, Felix Eisenhauer, Linda Armas, Joe Esquivel

4.2 2020/2021 RSD/RTA Distance Learning MOU

It is recommended the board take action and approve the 2020/2021 RSD/RTA Distance Learning MOU and direct the administration to meet and support revisions with RTA.

Motion by Eleanor Torres, second by Edith Martinez-Cortes.

Final Resolution: Motion Carries

Yes: Eleanor Torres, Edith Martinez-Cortes, Felix Eisenhauer, Linda Armas, Joe Esquivel

4.3 Approval of the Contract with Diane DeLaurentis to Provide Performing Arts Services FY 2020/2021

Staff recommends approval of the Contract Renewal with Diane DeLaurentis for Performing Arts Services.

Motion by Felix Eisenhauer, second by Edith Martinez-Cortes.

Final Resolution: Motion Carries

Yes: Eleanor Torres, Edith Martinez-Cortes, Felix Eisenhauer, Linda Armas, Joe Esquivel

4.4 Goals Development Workshop

Joe Condon and Brooke Jimenez, consultants, conducted the Goals Development Workshop. Discussion continued amongst the board members. The Governing Board agreed to meet again for further discussions.

5. Adjournment

5.1 Adjournment

President Armas adjourned the meeting at 7:34 p.m.

Eleanor Torres, Clerk of the Board

John Puglisi, Ph.D., Secretary to the Board

9.4



Agenda Item Details

Meeting Oct 21, 2020 - RSD Regular Board Meeting
 Category 9. Consent
 Subject 9.4 Approval of the Donation Report
 Access Public
 Type Action (Consent)
 Recommended Action Staff recommends approval of the Donation Report.

Public Content

Speaker: Superintendent Puglisi

Rationale:

It is recommended the Governing Board accepts the following donations:

Site	Donor	Use of Donation	Amount	
RDN	Reyes Coca Cola Bottling	Teacher Incentives	35.92	
RRE	Camarillo Ranch Foundation	Teacher Incentives	500.00	
RL	Life Touch	Teacher Incentives	88.00	
RRE	Your Cause	Teacher Incentives	70.00	Administrative Content
RL	Your Cause	Teacher Incentives	175.00	
RL	Your Cause	Teacher Incentives	175.00	
RDS	Life Touch	Teacher Incentives	224.00	
RRE	Your Cause	Teacher Incentives	60.00	
RRE	Box Tops	Teacher Incentives	39.50	Executive Content
RV	Reyes Coca Cola	Teacher Incentives	21.23	
RDV	Standard Industries	Teacher Incentives	49.46	
RDS	PTSA	Teacher Incentives	2000.00	

Our adopted rules of Parliamentary Procedure, Robert's Rules, provide for a consent agenda listing several items for approval of the Board by a single motion. Most of the items listed under the consent agenda have gone through Board subcommittee review and recommendation. Documentation concerning these items has been provided to all Board members and the public in advance to assure an extensive and thorough review. Items may be removed from the consent agenda at the request of any board member.

9.5



Agenda Item Details

Meeting	Oct 21, 2020 - RSD Regular Board Meeting
Category	9. Consent
Subject	9.5 October 2020 Personnel Report
Access	Public
Type	Action (Consent)
Recommended Action	It is recommended the board take action and approve the October 2020 personnel report as presented.
Goals	Goal 5-Recruit, hire, train, and retain exemplary employees who are caring, committed, collaborative, creative and critical thinkers.

Public Content

Speaker: Carolyn Bernal

Rationale: The October 2020 personnel report is presented for approval.

October PERS Report - October 21, 2020.pdf (50 KB)

Administrative Content

Executive Content

Our adopted rules of Parliamentary Procedure, Robert's Rules, provide for a consent agenda listing several items for approval of the Board by a single motion. Most of the items listed under the consent agenda have gone through Board subcommittee review and recommendation. Documentation concerning these items has been provided to all Board members and the public in advance to assure an extensive and thorough review. Items may be removed from the consent agenda at the request of any board member.

RIO SCHOOL DISTRICT
October 21, 2020

Certificated Personnel Report

Certificated Ratification of Employment:

Farewell, Chad, Rio del Sol (.60) FTE/Rio del Valle (.40) FTE to Rio del Sol (1.0) FTE, Effective 20/21 School Year
Kirk, Raymond, Rio del Sol (.20) FTE to (.60) FTE, Effective 20/21 School Year

Classified Personnel Report

Classified Promotion:

Rivera, Maria, from Clerk Typist II, (5.75) hours, District Office to Data Analyst, (8) hours, District Office, effective 9/21/20

Classified Ratification of Employment:

Rosales, Brenda, Student & Family Support Specialist, (5.75) hours, Rio Vista, effective 9/11/20

9.6



Agenda Item Details

Meeting	Oct 21, 2020 - RSD Regular Board Meeting
Category	9. Consent
Subject	9.6 Ratification of the Commercial Warrant for September 2, 2020 through October 8, 2020.
Access	Public
Type	Action
Fiscal Impact	Yes
Dollar Amount	5,000,653.22
Budgeted	Yes
Budget Source	Various Funds as listed below.
Recommended Action	It is recommended that the Commercial Warrant be approved for the period September 2, 2020, through October 8, 2020.

Public Content

Speaker:
Wael Saleh, Assistant Superintendent

Rationale:

The District processed payments to vendors since the last meeting of the Governing Board for a total amount of \$5,000,653.22 which includes processing payments for all funds of the District in the following amounts for the period September 2, 2020 through October 8, 2020.

Fund 010	General Fund	\$2,203,327.14
Fund 130	Cafeteria Fund	\$360,804.39
Fund 212	Building Fund Measure L	\$2,331,054.57
Fund 251	CAPITAL FACILITIES - RESIDENTIAL	\$87,131.78
Fund 490	Capital Projects Fund for Blen	<u>\$19,510.00</u>
Total		\$5,001,827.88
Less Unpaid Tax Liability		<u>-\$1,174.66</u>
Total:		\$5,000,653.22

[Board Report of checks 10-8-20.pdf \(143 KB\)](#)

Administrative Content

Executive Content

Checks Dated 09/02/2020 through 10/08/2020

Check Number	Check Date	Pay to the Order of	Fund	Expensed Amount	Check Amount
4009086629	09/02/2020	Kathryn Aragon	Cancelled		338.12 *
Cancel	1	338.12			
			Total Number of Checks	1	.00
5009038377	09/03/2020	360 Degree Customer Inc.	010	16,672.50	
5009038378	09/03/2020	Bertrands Music (Pedersens)	010	1,901.69	
5009038379	09/03/2020	SCHOOL SPECIALTY	010	344.37	
5009038380	09/03/2020	FRONTLINE TECH. GROUP, LLC	010	700.00	
5009038381	09/03/2020	Diane DeLaurantis	010	6,500.00	
5009038382	09/03/2020	Diverse Education Resources	010	6,241.52	
5009038383	09/03/2020	Ellevation Inc.	010	24,750.00	
5009038384	09/03/2020	ESGI	010	3,195.00	
5009038385	09/03/2020	FOLLETT SCHOOL SOLUTIONS, INC.	010	17,718.60	
5009038386	09/03/2020	GOPHER SPORTS	010	4,181.96	
5009038388	09/03/2020	Learning Priority, Inc	010	4,950.00	
5009038390	09/03/2020	MHS	010	8,340.00	
5009038391	09/03/2020	Newsela, Inc	010	3,750.00	
5009038392	09/03/2020	ROCHESTER 100 INC. NICKY'S COMMUNICATOR	010	545.48	
5009038393	09/03/2020	Ox Blue	010	290.00	
5009038395	09/03/2020	PEARSON	010	2,660.12	
5009038398	09/03/2020	REALLY GOOD STUFF	010	131.56	
5009038399	09/03/2020	Savvas Learning Company	010	19,753.48	
5009038400	09/03/2020	Scholastic Inc.	010	2,854.80	
5009038401	09/03/2020	School Datebooks, Inc.	010	4,780.86	
5009038402	09/03/2020	SCHOOL NURSE SUPPLY, INC.	010	2,148.44	
5009038403	09/03/2020	Seesaw Learning, Inc.	010	11,818.95	
5009038404	09/03/2020	SETON IDENTIFICATION PRODUCTS	010	2,535.19	
5009038405	09/03/2020	Studies Weekly	010	137.06	
5009038406	09/03/2020	SUPER DUPER PUBLICATIONS	010	1,101.30	
5009038407	09/03/2020	Top Quality Manufacturing	010	646.23	
5009038408	09/03/2020	Universal Printing	010	2,436.48	
5009038409	09/04/2020	Vasan, Padmini	010	631.64	
5009038410	09/04/2020	Arceo, Lucila	010	38.48	
5009038411	09/04/2020	Nelson, Heather M	010	827.40	
5009038412	09/04/2020	Maria, Julie E	010	279.52	
5009038413	09/04/2020	Martinez, Mindy L	010	66.72	
5009038414	09/04/2020	Muller, Katherine	010	193.94	
5009038415	09/04/2020	Hernandez, Oscar G	010	300.00	
5009038419	09/04/2020	Oxnard Union High	010	7,954.88	
5009038420	09/04/2020	Sphero, Inc.	010	2,212.48	
5009038423	09/08/2020	CASP	010	155.00	
5009038424	09/08/2020	De Lage Landen Financial Servi ces, Inc.	010	407.30	
5009038425	09/08/2020	ESGI	010	812.00	

The preceding Checks have been issued in accordance with the District's Policy and authorization of the Board of Trustees. It is recommended that the preceding Checks be approved.

Checks Dated 09/02/2020 through 10/08/2020

Check Number	Check Date	Pay to the Order of	Fund	Expensed Amount	Check Amount
5009038426	09/08/2020	Carlo Andre Godoy dba Godoy Studios	010	7,275.00	
5009038429	09/08/2020	SERVICE PRO-FIRE PROTECTION	010	3,363.44	
5009038432	09/10/2020	Young, Russell	010	60.00	
5009038433	09/10/2020	ACSA	010	440.00	
5009038434	09/10/2020	Aquaax, LLC	010	4,600.00	
5009038435	09/10/2020	COASTAL OCCUPATIONAL MEDICAL GROUP	010	330.00	
5009038436	09/10/2020	ESGI	010	1,624.00	
5009038437	09/10/2020	Firefly Computers, LLC	010	8,618.93	
5009038438	09/10/2020	Frontier Communications	010	173.82	
5009038439	09/10/2020	John Gosnell DBA Gforce Printing	010	9,401.28	
5009038442	09/10/2020	KONICA MINOLTA PREMIER FINANCE	010	1,556.32	
5009038444	09/10/2020	Lawrence A. Wolf	010	4,590.00	
5009038445	09/10/2020	LAZEL	010	5,247.50	
5009038446	09/10/2020	Blue Duck Education, Ltd.	010	4,350.00	
5009038447	09/10/2020	Myers, Widders, Gibson, Jones	010	2,162.06	
5009038448	09/10/2020	OTC BRANDS, INC.	010	433.00	
5009038449	09/10/2020	Oxnard Union High	010	321.92	
5009038455	09/10/2020	SCHOLASTIC BOOK CLUBS, INC.	010	597.19	
5009038458	09/10/2020	VENTURA COUNTY SELF-FUNDING AUTHORITY	010	266,519.00	
5009038460	09/10/2020	Wayside Publishing	010	1,560.00	
5009038461	09/10/2020	WEVideo Inc.	010	6,900.00	
5009038462	09/10/2020	Broadview Networks	010	8,066.81	
5009038463	09/10/2020	WINZER	010	14,955.92	
5009038464	09/10/2020	Western Psychological Services	010	273.80	
5009038465	09/10/2020	XEROX CORPORATION	010	3,068.22	
5009038466	09/14/2020	California Teacher Credentialing	010	100.00	
5009038468	09/14/2020	Atkinson, Andelson, Loya, Ruud & Romo	010	1,000.00	
5009038469	09/14/2020	edpuzzle	010	1,300.00	
5009038471	09/14/2020	KONICA MINOLTA BUSINESS SOLUTIONS USA, INC.	010	3,693.17	
5009038472	09/14/2020	KONICA MINOLTA PREMIER FINANCE	010	2,843.34	
5009038474	09/14/2020	Mutual of Omaha Policyholder Services	010	763.14	
5009038478	09/14/2020	SC FUELS	010	5,764.97	
5009038479	09/14/2020	SERVICE PRO-FIRE PROTECTION	010	7,416.00	
5009038480	09/14/2020	SISC FINANCE	010	605,947.75	
5009038482	09/14/2020	Smith Pipe & Supply	010	351.59	
5009038483	09/14/2020	Southwest School & Office Supply	010	15,141.68	
5009038485	09/14/2020	Sunbelt Rentals	010	4,288.14	
5009038486	09/14/2020	Wireless CCTV LLC	010	3,000.00	
5009038487	09/15/2020	Emery, Ryan	010	801.71	

The preceding Checks have been issued in accordance with the District's Policy and authorization of the Board of Trustees. It is recommended that the preceding Checks be approved.

ESCAPE ONLINE

Page 2 of 10

Checks Dated 09/02/2020 through 10/08/2020

Check Number	Check Date	Pay to the Order of	Fund	Expensed Amount	Check Amount
5009038488	09/15/2020	Ron Obrien dba Bee Specialist	010	375.00	
5009038489	09/15/2020	California American Water	010	4,838.55	
5009038490	09/15/2020	CITY OF OXNARD	010	16,245.12	
5009038491	09/15/2020	SOUTHERN CALIF. EDISON	010	36,531.56	
5009038492	09/15/2020	Frontier Communications	010	306.06	
5009038493	09/15/2020	THE GAS COMPANY	010	94.06	
5009038494	09/15/2020	VCOE GRAPHICS CENTER	010	9,187.07	
5009038495	09/15/2020	GREATAMERICA FINANCIAL SVCS	010	279.09	
5009038496	09/15/2020	HARRIS WATER CONDITIONING	010	194.41	
5009038497	09/15/2020	Jonathan Brendefur DBA DMTA	010	5,000.00	
5009038498	09/15/2020	CITY OF OXNARD OXNARD FIRE DEPARTMENT	010	1,473.00	
5009038499	09/15/2020	Riverside Insights	010	2,572.00	
5009038500	09/15/2020	UNITED WATER CONSERVATION DIST	010	2,545.31	
5009038501	09/15/2020	U.S. Bank Corporate Payment Systems	010	16,443.70	
5009038502	09/15/2020	Ventura County Office of Education	010	35.00	
5009038504	09/15/2020	Broadview Networks	010	8,250.72	
5009038505	09/15/2020	Wonder Media, LLC	010	34,250.00	
5009038507	09/17/2020	Ramirez, Jisela	010	63.25	
5009038508	09/17/2020	Guenther, Meagan	010	25.00	
5009038509	09/17/2020	Gray, Ethan T	010	52.43	
5009038510	09/17/2020	AMAZON.COM CORPORATE CREDIT	010	56,976.93	
5009038511	09/17/2020	Atkinson, Andelson, Loya, Ruud & Romo	010	35,077.50	
5009038512	09/17/2020	BARON INDUSTRIES	010	990.92	
5009038513	09/17/2020	California Lutheran University CRLP	010	1,600.00	
5009038514	09/17/2020	Deltamath Solutions, LLC	010	600.00	
5009038515	09/17/2020	Demsey, Filliger & Associates	010	2,500.00	
5009038516	09/17/2020	FEDEX	010	268.98	
5009038517	09/17/2020	Franklin Covey	010	322.24	
5009038518	09/17/2020	Imagine Learning, Inc.	010	55,000.00	
5009038519	09/17/2020	IXL Learning	010	7,331.00	
5009038520	09/17/2020	Marcus Lopez	010	175.00	
5009038521	09/17/2020	MWG MESTMAKER & ASSOCIATES	010	160.00	
5009038522	09/17/2020	Open Up Resources	010	4,663.25	
5009038525	09/17/2020	SCRIPPS NATIONAL SPELLING BEE	010	164.50	
5009038526	09/17/2020	TREBRON COMPANY, INC	010	12,833.13	
5009038527	09/17/2020	TENNANT SALES AND SERVICE CO.	010	344.37	
5009038529	09/17/2020	VCOE Business	010	2,259.88	
5009038530	09/21/2020	AIRPORT AUTO TECH	010	1,905.87	
5009038531	09/21/2020	ALL-PHASE ELECTRIC SUPPLY	010	237.39	
5009038532	09/21/2020	Amerigas	010	88.48	
5009038533	09/21/2020	APPLIED BACKFLOW TECHNOLOGIES	010	600.00	
5009038534	09/21/2020	Aswell Trophy	010	85.12	

The preceding Checks have been issued in accordance with the District's Policy and authorization of the Board of Trustees. It is recommended that the preceding Checks be approved.

ESCAPE ONLINE

Page 3 of 10

Checks Dated 09/02/2020 through 10/08/2020

Check Number	Check Date	Pay to the Order of	Fund	Expensed Amount	Check Amount
5009038535	09/21/2020	C & M AUTO TRUCK ELECTRIC	010	781.87	
5009038536	09/21/2020	CCP Industries Inc.	010	416.39	
5009038538	09/21/2020	COGGS TIRE SERVICE	010	76.29	
5009038539	09/21/2020	Eckharts Trailer Hitch & Welding, Inc.	010	1,000.33	
5009038540	09/21/2020	ESGI	010	2,932.00	
5009038541	09/21/2020	Ewing Irrigation Products Inc	010	762.35	
5009038542	09/21/2020	F.G.Wilcox, Inc.	010	93.13	
5009038543	09/21/2020	FEDEX	010	120.81	
5009038544	09/21/2020	Fence Factory	010	193.96	
5009038545	09/21/2020	FERGUSON FACILITIES SUPPLY	010	68.22	
5009038546	09/21/2020	FGL Environmental	010	168.00	
5009038547	09/21/2020	Green Thumb Nursery	010	482.79	
5009038548	09/21/2020	IXL Learning	010	750.00	
5009038550	09/21/2020	LAZEL	010	6,096.75	
5009038551	09/21/2020	Nee Quaison Sackey	010	1,400.00	
5009038552	09/21/2020	Auto Plus Auto Parts	010	2,732.53	
5009038553	09/21/2020	Regency Enterprises, Inc.	010	1,098.41	
5009038555	09/21/2020	TAFT ELECTRIC	010	950.00	
5009038556	09/21/2020	TELCOM, INC	010	1,841.60	
5009038558	09/21/2020	Traffic Technologies, LLC	010	735.18	
5009038559	09/21/2020	VC Metals Inc	010	38.79	
5009038560	09/21/2020	Ventura County Office of Education	010	1,450.00	
5009038561	09/21/2020	STEVE ZOLOTAS DBA WEST OAKS PEST CONTROL	010	7,238.00	
5009038562	09/21/2020	WINZER	010	945.95	
5009038563	09/21/2020	YAMA LAWNMOWER REPAIR	010	3,610.37	
5009038564	09/22/2020	Yurof, Josefina	010	80.82	
5009038565	09/22/2020	Gray, Ethan T	010	215.49	
5009038566	09/22/2020	De Lage Landen Financial Servi ces, Inc.	010	213.84	
5009038567	09/22/2020	Global Equity Communications	010	3,525.00	
5009038569	09/22/2020	Grainger	010	3,800.19	
5009038570	09/22/2020	House Sanitary Supply	010	2,185.08	
5009038572	09/22/2020	Super Nature Adventures	010	2,800.00	
5009038573	09/22/2020	Gary Robinson DBA Tribal Eye Productions	010	3,834.88	
5009038575	09/24/2020	Vasquez, Carmen	010	296.66	
5009038576	09/24/2020	Mendez, Adeline	010	413.73	
5009038577	09/24/2020	Escobar, Hugo M	010	49.11	
5009038578	09/24/2020	Martinez, Oscar	010	57.00	
5009038579	09/24/2020	American Plastics Corp	010	2,418.49	
5009038581	09/24/2020	BARON INDUSTRIES	010	163.94	
5009038584	09/24/2020	EdClub Inc.	010	261.44	
5009038585	09/24/2020	ESGI	010	1,065.00	
5009038587	09/24/2020	Food Corps	010	7,500.00	
5009038588	09/24/2020	HOME DEPOT CREDIT SERVICES	010	13,147.81	
5009038589	09/24/2020	Imagine Learning, Inc.	010	4,500.00	

The preceding Checks have been issued in accordance with the District's Policy and authorization of the Board of Trustees. It is recommended that the preceding Checks be approved.

ESCAPE ONLINE

Page 4 of 10

Checks Dated 09/02/2020 through 10/08/2020

Check Number	Check Date	Pay to the Order of	Fund	Expensed Amount	Check Amount
5009038590	09/24/2020	IXL Learning	010	5,245.00	
5009038592	09/24/2020	Kimball Midwest	010	3,702.75	
5009038593	09/24/2020	Lawson Products	010	1,220.60	
5009038594	09/24/2020	McCARTY & SON'S TOWING	010	312.50	
5009038596	09/24/2020	MONTGOMERY HARDWARE CO.	010	1,255.91	
5009038597	09/24/2020	Nason's Lock & Safe Inc DBA Nasons Lock & Security	010	81.82	
5009038598	09/24/2020	O'Reilly Auto Parts	010	7,268.91	
5009038599	09/24/2020	Auto Plus Auto Parts	010	799.42	
5009038602	09/24/2020	TELCOM, INC	010	410.79	
5009038604	09/24/2020	Ventura County Office of Education	010	407.50	
5009038605	09/24/2020	Western Psychological Services	010	450.00	
5009038606	09/24/2020	YAMA LAWNMOWER REPAIR	010	21.54	
5009038609	09/28/2020	Downing, Courtney A	010	8.29	
5009038612	09/28/2020	Customink	010	633.21	
5009038613	09/28/2020	JW Pepper & Son, Inc.	010	53.83	
5009038614	09/28/2020	Nearpod Contact	010	2,000.00	
5009038616	09/28/2020	STARFALL EDU. FOUNDATION	010	540.00	
5009038617	09/28/2020	Steve Sunnarborg	010	1,479.36	
5009038619	09/28/2020	Wayside Publishing	010	1,560.00	
5009038623	09/29/2020	Learning Without Tears	010	466.43	
5009038624	09/29/2020	OFFICE DEPOT	010	28,409.87	
5009038626	09/29/2020	Screencastify,LLC	010	15,750.00	
5009038627	09/29/2020	Ventura County Office of Education	010	50,889.80	
5009038628	09/29/2020	VERIZON WIRELESS	010	806.53	
5009038629	10/01/2020	Mosqueda, Margarita	010	40.86	
5009038630	10/01/2020	Hernandez, Maria M	010	53.90	
5009038631	10/01/2020	Gilbert Acosta	010	2,279.10	
5009038632	10/01/2020	Maria Acosta	010	2,279.10	
5009038633	10/01/2020	Marylou Almilli	010	2,279.10	
5009038634	10/01/2020	SALLY ALVARADO	010	2,279.10	
5009038635	10/01/2020	BARBARA ALVIDREZ	010	2,279.10	
5009038636	10/01/2020	Amplified IT	010	46,404.00	
5009038637	10/01/2020	Maria Angeles	010	2,279.10	
5009038638	10/01/2020	Anthony Urban	010	2,279.10	
5009038639	10/01/2020	Wayne Antrobus	010	2,279.10	
5009038640	10/01/2020	Assistance League School	010	6,900.00	
5009038641	10/01/2020	REBECCA BARBETTI	010	2,279.10	
5009038642	10/01/2020	Sharon Bellman	010	2,279.10	
5009038643	10/01/2020	Maria Benitez	010	2,279.10	
5009038644	10/01/2020	Belinda Betancourt	010	2,279.10	
5009038645	10/01/2020	SHIRLEY BROWN	010	2,279.10	
5009038646	10/01/2020	Julie Burchmore	010	2,279.10	
5009038647	10/01/2020	Carmen Carrillo	010	2,279.10	
5009038648	10/01/2020	Jonathan Castillo	010	2,279.10	
5009038649	10/01/2020	Stephen Clark	010	1,075.00	

The preceding Checks have been issued in accordance with the District's Policy and authorization of the Board of Trustees. It is recommended that the preceding Checks be approved.

ESCAPE ONLINE

Page 5 of 10

Checks Dated 09/02/2020 through 10/08/2020

Check Number	Check Date	Pay to the Order of	Fund	Expensed Amount	Check Amount
5009038650	10/01/2020	COASTAL OCCUPATIONAL MEDICAL GROUP	010	305.00	
5009038651	10/01/2020	GAYLE COLEMAN	010	2,279.10	
5009038652	10/01/2020	Teresa Blanche Contreras	010	2,279.10	
5009038653	10/01/2020	John Cort	010	2,279.10	
5009038654	10/01/2020	Arla B Crane	010	2,279.10	
5009038655	10/01/2020	Kathleen Crowe	010	2,279.10	
5009038656	10/01/2020	David Davidson	010	2,279.10	
5009038657	10/01/2020	LaVerne Edgar	010	2,279.10	
5009038658	10/01/2020	Catherine Espinoza	010	2,279.10	
5009038659	10/01/2020	Carolee Felch	010	2,279.10	
5009038660	10/01/2020	Jeanne Foster	010	2,279.10	
5009038661	10/01/2020	KATHLEEN FRANKLIN	010	2,279.10	
5009038662	10/01/2020	Susanne Frank	010	2,279.10	
5009038663	10/01/2020	Ruth Fraser	010	2,279.10	
5009038664	10/01/2020	JARREL FULLER	010	2,279.10	
5009038665	10/01/2020	Claudene Garmon	010	2,279.10	
5009038666	10/01/2020	John Gosnell DBA Gforce Printing	010	1,446.01	
5009038667	10/01/2020	Geoff Godfrey	010	2,279.10	
5009038668	10/01/2020	Maria L. Godinez	010	2,279.10	
5009038669	10/01/2020	Helene Gollub	010	2,279.10	
5009038670	10/01/2020	CAROLYN GRACE	010	2,279.10	
5009038671	10/01/2020	Susan Hamada	010	2,279.10	
5009038672	10/01/2020	Milton R. Harrion	010	2,279.10	
5009038674	10/01/2020	Imagine Learning, Inc.	010	27,950.00	
5009038675	10/01/2020	Harold Kennedy	010	2,279.10	
5009038676	10/01/2020	Jo Ann Kennedy	010	2,279.10	
5009038677	10/01/2020	Georgia Kerns	010	2,279.10	
5009038678	10/01/2020	LAURA KRALL	010	2,279.10	
5009038679	10/01/2020	Meredith Kruger	010	2,279.10	
5009038680	10/01/2020	RENEE LANE	010	2,279.10	
5009038681	10/01/2020	Learning Priority, Inc	010	4,950.00	
5009038682	10/01/2020	Christina Leonard	010	2,279.10	
5009038683	10/01/2020	CONNIE LOMELI	010	2,279.10	
5009038684	10/01/2020	BEN LUCE	010	2,279.10	
5009038685	10/01/2020	Marcia Marino	010	2,279.10	
5009038686	10/01/2020	Maxim Healthcare Staffing	010	1,200.00	
5009038687	10/01/2020	Joan Mayeda	010	2,279.10	
5009038688	10/01/2020	Shirley McCafferty	010	2,279.10	
5009038689	10/01/2020	Gail Nakamura-Meagher	010	2,279.10	
5009038690	10/01/2020	Natus	010	358.81	
5009038691	10/01/2020	Virginia Nedeleff	010	2,279.10	
5009038692	10/01/2020	Phil Otero	010	2,279.10	
5009038693	10/01/2020	Oxnard Union High	010	4,082.73	
5009038694	10/01/2020	RUDY PALAZUELOS	010	2,279.10	
5009038695	10/01/2020	PARADIGM HEALTHCARE SERVICES	010	1,948.77	

The preceding Checks have been issued in accordance with the District's Policy and authorization of the Board of Trustees. It is recommended that the preceding Checks be approved.

ESCAPE ONLINE

Page 6 of 10

Checks Dated 09/02/2020 through 10/08/2020

Check Number	Check Date	Pay to the Order of	Fund	Expensed Amount	Check Amount
5009038696	10/01/2020	Pattis R. Thompson	010	2,279.10	
5009038698	10/01/2020	YVONNE RAILEY	010	2,279.10	
5009038699	10/01/2020	Hekar Rivera	010	1,300.00	
5009038700	10/01/2020	Jose Rodriguez	010	2,279.10	
5009038701	10/01/2020	SALLIE SANCHEZ	010	2,279.10	
5009038702	10/01/2020	SCRIPPS NATIONAL SPELLING BEE	010	164.50	
5009038703	10/01/2020	SCRIPPS NATIONAL SPELLING BEE	010	164.50	
5009038704	10/01/2020	SCRIPPS NATIONAL SPELLING BEE	010	164.50	
5009038705	10/01/2020	Darlene Serros	010	2,279.10	
5009038706	10/01/2020	Linda Shaffer	010	2,279.10	
5009038707	10/01/2020	Andrea Shaub	010	2,279.10	
5009038708	10/01/2020	LYNN SILVIERA	010	2,279.10	
5009038709	10/01/2020	CAROL SPRACKLEN	010	2,279.10	
5009038710	10/01/2020	BEVERLY STARK	010	2,279.10	
5009038711	10/01/2020	Virginia Swickard	010	2,279.10	
5009038712	10/01/2020	Eleanor Syrett	010	2,279.10	
5009038713	10/01/2020	Tax Deferred Services Corporate Office Suite 209	010	87,255.00	
5009038714	10/01/2020	TeacherFit, LLC	010	1,770.00	
5009038715	10/01/2020	Gwen Thomas	010	2,279.10	
5009038716	10/01/2020	HELEN TORRES	010	2,279.10	
5009038717	10/01/2020	U.S. Bank Corporate Payment Systems	010	34,269.09	
5009038718	10/01/2020	Christina Valdivia	010	2,279.10	
5009038719	10/01/2020	Vivo Technology, LLC	010	5,686.13	
5009038720	10/01/2020	Lenora Weinerth	010	2,279.10	
5009038721	10/01/2020	Darylene Williams	010	2,279.10	
5009038722	10/01/2020	Sharlene Wilson	010	2,279.10	
5009038723	10/01/2020	Mike Wittlin	010	2,279.10	
5009038724	10/01/2020	Dr. Elizabeth Yeager	010	2,681.25	
5009038725	10/05/2020	Mendoza, Jo Anna	010	90.03	
5009038726	10/05/2020	Guenther, Meagan	010	37.61	
5009038727	10/05/2020	Cordova, Ralph	010	281.92	
5009038728	10/05/2020	AT&T	010	5,904.62	
5009038730	10/05/2020	IXL Learning	010	7,877.00	
5009038731	10/05/2020	Blaine Kutin	010	515.25	
5009038734	10/05/2020	Nee Quaison Sackey	010	1,450.00	
5009038735	10/05/2020	OFFICE DEPOT	010	41,773.90	
5009038737	10/05/2020	Sonitrol	010	723.93-	
5009038740	10/06/2020	Mosqueda, Margarita	010	174.19	
5009038741	10/06/2020	Escobar, Hugo M	010	12.00	
5009038743	10/06/2020	Lam, Phaedra	010	175.88	
5009038744	10/06/2020	Koga, Rickey K	010	771.27	
5009038745	10/06/2020	Stephenson, Rachel L	010	155.93	
5009038746	10/06/2020	Murillo, Vanessa C	010	38.79	
5009038747	10/06/2020	AT&T	010	654.76	

The preceding Checks have been issued in accordance with the District's Policy and authorization of the Board of Trustees. It is recommended that the preceding Checks be approved.

ESCAPE ONLINE

Page 7 of 10

Checks Dated 09/02/2020 through 10/08/2020

Check Number	Check Date	Pay to the Order of	Fund	Expensed Amount	Check Amount
5009038748	10/06/2020	Atkinson, Andelson, Loya, Ruud & Romo	010	34,956.82	
5009038749	10/06/2020	Comeco Inc	010	2,358.90	
5009038750	10/06/2020	Flocabulary	010	2,500.00	
5009038752	10/06/2020	Blaine Kutin	010	2,370.15	
5009038753	10/06/2020	Lawrence A. Wolf	010	4,590.00	
Total Number of Checks			303	2,203,327.14	
5009038397	09/03/2020	Puretec Industrial Water	130	214.50	
5009038416	09/04/2020	COUNTY OF VENTURA GENERAL SERVICES AGENCY	130	2,672.10	
5009038417	09/04/2020	Driftwood Dairy, Inc.	130	45,861.87	
5009038421	09/04/2020	SYSCO VENTURA, INC.	130	200,356.70	
5009038422	09/04/2020	THE BERRY MAN, INC.	130	70,736.60	
5009038452	09/10/2020	Puretec Industrial Water	130	90.00	
5009038478	09/14/2020	SC FUELS	130	402.63	
5009038501	09/15/2020	U.S. Bank Corporate Payment Systems	130	99.00	
5009038503	09/15/2020	VENTURA REFRIGERATION SALES & SERVICE	130	996.39	
5009038506	09/17/2020	Teresa Acosta	130	9.50	
5009038524	09/17/2020	Puretec Industrial Water	130	381.00	
5009038554	09/21/2020	SYSCO VENTURA, INC.	130	25,766.69	
5009038557	09/21/2020	THE BERRY MAN, INC.	130	7,961.60	
5009038571	09/22/2020	Puretec Industrial Water	130	190.50	
5009038574	09/24/2020	Laubacher Farms	130	1,620.00	
5009038607	09/28/2020	Gutierrez, Rosaizela M	130	47.52	
5009038608	09/28/2020	Alfaro, Maria	130	82.95	
5009038618	09/28/2020	VENTURA REFRIGERATION SALES & SERVICE	130	222.47	
5009038697	10/01/2020	Puretec Industrial Water	130	285.75	
5009038732	10/05/2020	Laubacher Farms, inc	130	2,502.00	
5009038735	10/05/2020	OFFICE DEPOT	130	251.90	
5009038742	10/06/2020	Alfaro, Maria	130	52.72	
Total Number of Checks			22	360,804.39	
5009038387	09/03/2020	KENCO CONSTRUCTION SERVICES	212	7,560.00	
5009038389	09/03/2020	Magnum Fence Securities	212	3,021.00	
5009038394	09/03/2020	PACIFIC COAST SOUND AND COMMUNICATIONS, INC	212	17,960.00	
5009038396	09/03/2020	Professional Security Guard	212	11,790.00	
5009038402	09/03/2020	SCHOOL NURSE SUPPLY, INC.	212	1,248.28	
5009038418	09/04/2020	Kamran & Company, Inc Attn Dorie Prulitsky	212	1,363.88	
5009038427	09/08/2020	Hughes General Engineering	212	2,687.88	
5009038428	09/08/2020	MJP COMPUTERS	212	45,519.59	
5009038430	09/09/2020	DIV. OF THE STATE ARCHITECT	212	975.00	

The preceding Checks have been issued in accordance with the District's Policy and authorization of the Board of Trustees. It is recommended that the preceding Checks be approved.

ESCAPE ONLINE

Page 8 of 10

Checks Dated 09/02/2020 through 10/08/2020

Check Number	Check Date	Pay to the Order of	Fund	Expensed Amount	Check Amount
5009038431	09/09/2020	KENCO CONSTRUCTION SERVICES	212	6,720.00	
5009038437	09/10/2020	Firefly Computers, LLC	212	1,125.00	
5009038440	09/10/2020	JPI Development Group Inc.	212	4,512.50	
5009038441	09/10/2020	K & Z Cabinet Cpo. Inc.	212	75,922.34	
5009038443	09/10/2020	KYA Services, LLC	212	81,296.25	
5009038450	09/10/2020	Painting & Decor, Inc.	212	470,853.25	
5009038451	09/10/2020	Pierre Landscapes, Inc	212	132,457.55	
5009038453	09/10/2020	Reed Mechanical Systems Inc.	212	61,896.29	
5009038454	09/10/2020	RND Contractors, INC	212	31,350.00	
5009038456	09/10/2020	Brannon Inc Smith Electric Service	212	9,500.00	
5009038457	09/10/2020	Standard Drywall, Inc.	212	7,505.00	
5009038459	09/10/2020	Venco Electric	212	57,307.57	
5009038467	09/14/2020	ACH Mechanical Contractors	212	37,895.50	
5009038470	09/14/2020	JPI Development Group Inc.	212	1,187.50	
5009038473	09/14/2020	KYA Services, LLC	212	62,700.00	
5009038475	09/14/2020	Painting & Decor, Inc.	212	145,221.75	
5009038476	09/14/2020	Pierre Landscapes, Inc	212	9,025.00	
5009038477	09/14/2020	RND Contractors, INC	212	783.75	
5009038481	09/14/2020	Brannon Inc Smith Electric Service	212	2,426.30	
5009038484	09/14/2020	Standard Drywall, Inc.	212	49,400.00	
5009038501	09/15/2020	U.S. Bank Corporate Payment Systems	212	106.67	
5009038510	09/17/2020	AMAZON.COM CORPORATE CREDIT	212	1,144.81	
5009038528	09/17/2020	US BANK	212	1,000.00	
5009038537	09/21/2020	Civic Construction Associates	212	115,900.00	
5009038549	09/21/2020	KBZ Architects	212	56,867.00	
5009038568	09/22/2020	Got Shade	212	48,730.02	
5009038580	09/24/2020	A4E	212	32,360.50	
5009038582	09/24/2020	Channel Islands Roofing, Inc.	212	32,438.70	
5009038583	09/24/2020	Earth Systems Consultants	212	2,640.00	
5009038586	09/24/2020	Finish Line Paving	212	188,886.60	
5009038591	09/24/2020	KBZ Architects	212	56,673.19	
5009038595	09/24/2020	MJP COMPUTERS	212	24,160.73	
5009038600	09/24/2020	Pacific OneSource, Inc STS education	212	21,595.34	
5009038601	09/24/2020	Tech-Wall	212	75,690.30	
5009038603	09/24/2020	Tetra Tech Divisions	212	6,500.00	
5009038610	09/28/2020	Airtek	212	18,800.00	
5009038611	09/28/2020	Colbi Technologies, Inc	212	2,911.25	
5009038615	09/28/2020	Pacific OneSource, Inc STS education	212	1,093.01	
5009038620	09/29/2020	BALFOUR BEATTY CONSTRUCTION	212	69,112.00	
5009038621	09/29/2020	Channel Islands Roofing, Inc.	212	1,707.30	
5009038622	09/29/2020	Earth Systems Consultants	212	7,880.00	
5009038625	09/29/2020	PACIFIC COAST SOUND AND COMMUNICATIONS, INC	212	81,266.38	
5009038729	10/05/2020	BALFOUR BEATTY CONSTRUCTION	212	53,198.69	
5009038733	10/05/2020	M/M Mechanical Inc.	212	2,505.12	

The preceding Checks have been issued in accordance with the District's Policy and authorization of the Board of Trustees. It is recommended that the preceding Checks be approved.

ESCAPE ONLINE

Page 9 of 10

Checks Dated 09/02/2020 through 10/08/2020

Check Number	Check Date	Pay to the Order of	Fund	Expensed Amount	Check Amount
5009038736	10/05/2020	OLYMPIC KILNS	212	10,245.92	
5009038738	10/05/2020	Ventura County Star	212	1,442.36	
5009038751	10/06/2020	Hughes General Engineering	212	67,450.00	
5009038754	10/06/2020	N/V/5 West, Inc.	212	7,537.50	
Total Number of Checks			57	2,331,054.57	
5009038419	09/04/2020	Oxnard Union High	251	45,065.97	
5009038511	09/17/2020	Atkinson, Andelson, Loya, Ruud & Romo	251	1,750.00	
5009038673	10/01/2020	Hoffman, Vance and Worthington	251	5,000.00	
5009038737	10/05/2020	Sonitrol	251	35,035.81	
5009038748	10/06/2020	Atkinson, Andelson, Loya, Ruud & Romo	251	280.00	
Total Number of Checks			5	87,131.78	
5009038511	09/17/2020	Atkinson, Andelson, Loya, Ruud & Romo	490	4,900.00	
5009038523	09/17/2020	Pacific West Communities, Inc	490	7,500.00	
5009038739	10/05/2020	ZIONS BANK CORPORATE TRUST DIVISION	490	2,350.00	
5009038748	10/06/2020	Atkinson, Andelson, Loya, Ruud & Romo	490	4,760.00	
Total Number of Checks			4	19,510.00	

Fund Recap

Fund	Description	Check Count	Expensed Amount
010	General Fund	303	2,203,327.14
130	Cafeteria Fund	22	360,804.39
212	Building Fund Measure L	57	2,331,054.57
251	CAPITAL FACILITIES - RESIDENTI	5	87,131.78
490	Capital Projects Fund for Blen	4	19,510.00
Total Number of Checks		378	5,001,827.88
Less Unpaid Tax Liability			1,174.66-
Net (Check Amount)			5,000,653.22

The preceding Checks have been issued in accordance with the District's Policy and authorization of the Board of Trustees. It is recommended that the preceding Checks be approved.

ESCAPE ONLINE

9.7





Agenda Item Details

Meeting	Oct 21, 2020 - RSD Regular Board Meeting
Category	9. Consent
Subject	9.7 Williams Quarterly Complaint Report
Access	Public
Type	Action (Consent)
Fiscal Impact	No
Budgeted	No
Budget Source	Not Applicable
Recommended Action	Staff recommends board approval of quarterly report.

Public Content

Speaker: Oscar Hernandez

Rationale:

Education Code Section 35186 (d) requires a school district to report summarized data on the nature and resolution of all complaints on a quarterly basis to the county superintendent of schools and the governing board of the school district. The summaries shall be publicly reported on a quarterly basis at a regularly scheduled meeting of the governing board of the school district. The report shall include the number of complaints by general subject area with the number of resolved and unresolved complaints. The complaints and written responses shall be available as public records.

1 - UCP Quartely Report for October 2020.pdf (25 KB)

Administrative Content

Executive Content

Our adopted rules of Parliamentary Procedure, Robert's Rules, provide for a consent agenda listing several items for approval of the Board by a single motion. Most of the items listed under the consent agenda have gone through Board subcommittee review and recommendation. Documentation concerning these items has been provided to all Board members and the public in advance to assure an extensive and thorough review. Items may be removed from the consent agenda at the request of any board member.

Quarterly Report on Williams Uniform Complaints
 [Education Code Section 35186]
 Fiscal Year 2020-21

District: Rio School District

Person completing this form: John Puglisi

Title: Superintendent

Quarterly Report Submission Date: October 2020 (7/1/20 to 9/30/20)
 (check one) January 2021 (10/1/20 to 12/31/20)
 April 2021 (1/1/21 to 3/31/21)
 July 2021 (4/1/21 to 6/30/21)

Date for information to be reported publicly at governing board meeting: October 21, 2020

Please check the box that applies:

- No complaints were filed with any school in the district during the quarter indicated above.
- Complaints were filed with schools in the district during the quarter indicated above. The following chart summarizes the nature and resolution of these complaints.

General Subject Area	Total # of Complaints	# Resolved	# Unresolved
Textbooks and Instructional Materials	0	0	0
Teacher Vacancy or Misassignment	0	0	0
Facilities Conditions	0	0	0
Totals	0	0	0

 Name of District Superintendent

 Signature of District Superintendent



Agenda Item Details

Meeting	Oct 21, 2020 - RSD Regular Board Meeting
Category	9. Consent
Subject	9.8 Approval of Tobacco Use Prevention Education (TUPE) Tier 2 Consortium Grant MOU
Access	Public
Type	Action (Consent)
Fiscal Impact	No
Dollar Amount	25,000.00
Budgeted	Yes
Budget Source	TUPE Grant Funds
Recommended Action	Staff recommends board approval of TUPE MOU with VCOE.

Public Content

Speaker: Oscar Hernandez

Rationale:

Rio School District will work with the Ventura County Office of Education to assure compliance with the Tobacco Use Prevention Education grant requirements such as: TUPE school program, Healthy Kids survey, youth development and family and community engagement activities/programs. TUPE funds are intended to supplement existing district programs. Budget of \$25,000 from July 1, 2020 to June 30, 2021.

TUPE MOU 2020-21.pdf (1,634 KB)

Administrative Content

Executive Content

Our adopted rules of Parliamentary Procedure, Robert's Rules, provide for a consent agenda listing several items for approval of the Board by a single motion. Most of the items listed under the consent agenda have gone through Board subcommittee review and recommendation. Documentation concerning these items has been provided to all Board members and the public in advance to assure an extensive and thorough review. Items may be removed from the consent agenda at the request of any board member.

MEMORANDUM OF UNDERSTANDING BETWEEN VENTURA COUNTY OFFICE OF EDUCATION AND RIO SCHOOL DISTRICT SCHOOL DISTRICT

This Memorandum of Understanding (Agreement) is made and entered into by and between **Ventura County Office of Education (hereinafter referred to as VCOE) and Rio School District (hereinafter referred to as District)**. This Agreement confirms the District's implementation of the Tobacco-Use Prevention Education (TUPE) Tier 2 consortium grant. Agreement term is **July 1, 2020 to June 30, 2021**. Thereafter, the Agreement may be extended for up to two (2) additional one (1) year periods based on continued funding from California Department of Education (CDE) until June 30, 2023. Each agency agrees to participate fully in the TUPE program by providing the following services.

VCOE will:

- Provide TUPE Consortium Project Coordinator to monitor program implementation and compliance of a comprehensive tobacco-use prevention education program and support District in all areas of program implementation and evaluation.
- Provide Project Specialist Technician to oversee grant invoicing, contracts, budget and reporting deliverables, and tobacco-free certification.
- Provide Youth Development Operations Specialist to coordinate trainings and support District in Youth Development and Family and Community Engagement activities and programs, such as Friday Night Live (FNL), Friday Night Live Mentoring, FNL Youth Advisory Council, school and other community presentations and Teens Kick Ash Conference.
- Provide Project Specialist to support Youth Development and Family and Community Engagement activities and programs in District.
- Provide VCOE Department of Research and Evaluation Director to review accountability logs, other process data, and data related to measurable objectives on an ongoing basis which will be supplemented with California Healthy Kids Survey data as that data becomes available; analyze data collected from staff through the CSCS in combination with CHKS and other program data to provide a broad picture of progress toward both process and outcome objectives; analyze other program data related to the level of program implementation within each district; summarize data and provide reports to the collaborative and district implementers each year; meet regularly with TUPE District coordinators, VCOE TUPE Project Coordinator and collaborative members to present data and facilitate discussion regarding areas of program need and improvement.
- Provide and support CDE-approved TUPE curriculum, as well as, TUPE training opportunities, as applicable to the District, for the CATCH My Breath for grade 6; Project ALERT for grades 7 and 8; and the Stanford Tobacco Prevention Toolkit for grades 9-12. Discussions to substitute curriculum to accommodate distance learning will be directed by VCOE Project Coordinator with CDE consultation. At the end of year 1, CATCH My Breath will be reviewed by Project Coordinator, District Coordinators and teachers to determine if CATCH My Breath will be implemented again for years two and three.

TUPE Tier 2 Consortium Grant 2020-2023

- Provide training and/or support in the CDE-approved tobacco-use intervention strategies including Brief Intervention, Stanford Toolkit Healthy Futures Intervention Curriculum, and Brief Risk Reduction Interview Intervention Model.
- Provide District with Intervention Tracking Tool to monitor and report all intervention contacts.
- Provide and deliver through Cal-SAFE the Stanford Toolkit Healthy Futures Intervention curriculum to all identified pregnant and parenting minors.
- Provide information on cessation services, including the California Smokers' Helpline, through the Cessation Services and Resources Information document.
- Provide District with tracking tool to track cessation services referrals and follow up contacts.
- Coordinate and provide technical assistance (TA) for the administration of the California Healthy Kids Survey (CHKS), California School Staff Survey (CSSS), and California School Parent Survey (CSPS) in the 2020-2021 school year. VCOE will purchase required materials and cover the cost of required surveys; collaborate with WestEd to coordinate and schedule survey administration; collaborate with District to develop and submit Ventura County Custom Module to WestEd for review and approval;
- Provide technical assistance to ensure compliance with Tobacco-Free Certification requirements and signage.
- Facilitate five bi-monthly (every other month) TUPE Consortium Coordinator meetings.
- Meet individually with District quarterly to monitor progress towards goals, identify areas of need, and provide technical assistance.
- Collect District program implementation data and submit TUPE Data Collection Tool quarterly to track progress and outcome measures to determine areas for program improvement.

District will:

- Recruit and assign staff to serve as the District TUPE Coordinator. The Coordinator will participate in program implementation, monitoring, and evaluation including distributing and facilitating completion of accountability reporting logs, recording and reporting activities, and ensuring compliance with all grant requirements. Completed accountability reporting logs to be monitored and reviewed each semester.
- Assure the TUPE District Coordinator's participation in at least four of the five bi-monthly (every other month) TUPE Consortium Coordinator meetings. If the TUPE District Coordinator is unable to attend, a representative should attend in their place.
- Support the TUPE District Coordinator's participation in provided TUPE related professional development, program improvement, needs assessment and evaluation meetings and activities.
- Encourage TUPE District Coordinator's collaboration with site administrators (Principals, Assistant Principals or Designee) to generate and sustain support for the TUPE program. Components include: informing staff of and enforcing tobacco use policies; and ensuring delivery of the CDE-approved TUPE curriculum and efforts to provide intervention and cessation services, including appropriate referrals.

TUPE Tier 2 Consortium Grant 2020-2023

- Provide list of all District, schools and teachers to deliver TUPE curriculum, including grade level, class name, periods, number of students enrolled in each class, and projected month(s) that specific curriculum will be delivered.
- Designate teachers or other appropriate staff to participate in TUPE curriculum training and ensure effective delivery of the CDE-approved, research-validated TUPE curriculum as applicable to the District.
- Assure timely and accurate completion of accountability reporting logs for all TUPE curriculum and other TUPE services provided as required by the grant.
- Designate administrator, counselor or other appropriate staff to participate in tobacco-use/vaping intervention trainings and ensure that intervention counseling sessions are conducted by trained staff for students in violation of tobacco policies as a part of an alternative to suspension model, as well as identified tobacco users. Additionally, provide referrals to the California smoker's helpline and other available cessation resources both locally and online. Assure timely and accurate completion of Intervention Tracking Tool and Cessation Referral Tracking Tool.
- Refer pregnant minors and/or minor parents to Cal-SAFE and/or Ventura County Public Health for tobacco education, intervention and cessation support, and/or other prevention and support services.
- Collaborate with VCOE staff to organize TUPE specific youth development and engagement outreach and youth advocacy activities that may include workshops, skits, rallies, poster contests, creation of tobacco prevention public service announcements and other activities.
- Support the development and implementation of youth development and engagement activities such as Friday Night Live (FNL), FNL Mentoring, and FNL Youth Advisory Council.
- Coordinate and encourage student participation in school-wide and community activities and projects such as Red Ribbon Week; Great American Smoke Out, Kick Butts Day, and World No Tobacco Day. Provide tobacco-free incentive materials that encourage and support student participation at all participating school sites. Student incentives must have a tobacco-free message on the item and cannot be in the form of cash. Coordinate with VCOE for students to participate in annual Teens Kick Ash Conference.
- Assure compliance with the District Tobacco-Free Policy Certification requirements according to CDE regulations by ensuring effective communication of the Tobacco-Free board policies and administrative regulations to staff, students, families and community. District communication will include: bilingual Tobacco-Free signage at all district-owned property entrances and key areas, stating "Tobacco and Drug Use are Prohibited: Including E-Cigs and Vapes", staff and student handbooks, district and school websites, annual notifications, Annual Notice of Parents' Rights and Responsibilities, and announcements and reminders made at beginning of all school events.
- Annually review and update, if necessary, any applicable District Board Policies and Administrative Regulations that require updated tobacco specific language, procedures, and practices.

TUPE Tier 2 Consortium Grant 2020-2023

- Administer the CDE required components of: 1) the Cal-SCHLS System [California Healthy Kids Survey (CHKS), California School Staff Survey (CSSS), and California School Parent Survey (CSPS)] and, 2) the VCOE Custom Module. Districts who did not complete the administration of all required CHKS surveys in the 2019-20 School Year, due to school closures, will be required to administer CHKS to grades **8, 10, and 12** prior to **December 30, 2020**, to meet the TUPE grant mandates. In Year 2 (2021-22) of the grant, surveys to be administered to students in grades 6, 7, 9, 11, and to all students attending alternative educational programs. Students in grade 5 may be surveyed under the umbrella of TUPE with prior approval. Ensure that district policies and practices regarding the administration of surveys are followed, including, but not limited to, California Education Code, Board approval, and parent consent.
- If selected, participate in the statewide California Student Tobacco Survey (CSTS) and the Evaluation of Tobacco-Use Prevention Education Programs in California.
- Complete and submit district-level TUPE Data Collection Tool, online accountability reporting logs, and intervention and cessation tracking tools quarterly. Submission dates will be October 10th; January 10th; April 10th; and June 20th.
- Neither receive nor apply for funds, educational materials, or services from the tobacco or cannabis industries or any agency which has received funding from the tobacco or cannabis industries to implement tobacco-use prevention or intervention programs.

Fiscal Responsibilities:

The annual amount of the Agreement for the period of July 1, 2020 through June 30, 2021 shall not exceed a budget of **\$25,000.00** According to the CDE, if there is legislative action to reduce or defer the funding, the budgets will be amended accordingly for Year 2 and Year 3. **Funds are provided annually and carry over funds will not be allowed from year to year.**

Year 1 (20-21): **\$25,000.00**

Estimated Year 2 (21-22): **\$26,278.76**

Estimated Year 3 (22-23): **\$26,319.66.**

District will:

- Submit quarterly fiscal reports to include the Quarterly Expenditure Report and Invoice, as well as supporting documentation and the TUPE Fiscal Quarterly Narrative on the following due dates; **October 10th, January 10th, April 10th, and June 20th**. Contact VCOE, Project Specialist Technician for specific submission requirements.
- Expend funds as allowable. Examples of allowable budget categories considered for reimbursement by the VCOE Tier 2 Consortium grant include:
 - **Certificated and Classified Salaries** (District Coordinator, Site Coordinators, Youth Development Coordinators, and sub-costs) A District Coordinator is required. Funding for administrative personnel, other than the district coordinator cannot be funded through the TUPE grant.
 - **Employee Benefits** (Certificated/Classified)
 - **Materials & Supplies** (Office supplies, youth development activities)

TUPE Tier 2 Consortium Grant 2020-2023

- **Travel and Conference** (In-county mileage and out-of-county travel expenses associated with VCOE approved Youth Development activities)
- **Youth Development Transportation**

Please see Funding Restrictions for TUPE grants. (Exhibit B).

- Participate in annual budget meeting between VCOE staff and District designated TUPE Coordinator and at least one District fiscal staff representative.

TUPE Reporting Requirements:

All reports are due by the dates indicated below. Failure to submit all required reports by the appropriate due dates will result in future payments being delayed.

Accountability Reporting Logs:

- Data entered at time of service and reviewed quarterly by District Coordinator on the following dates: October 10th, January 10th, April 10th, and June 20th**

TUPE Data Collection Tool

- Due quarterly on the following dates: October 10th, January 10th, April 10th, and June 20th**

Termination

Both parties may terminate this Agreement at any time for any reason by providing 30 days written notice to either party. In the event of termination under this paragraph, District will be paid for all work provided to the date of termination, as long as such work meets the terms and conditions of this Agreement.

Default

If District defaults in the performance of any term or condition, District must remedy that default by a satisfactory performance within 10 days after receipt of written notice of the default. If the District fails to remedy the default within that time, then VCOE may terminate this contract with a final notice.

My signature below certifies that I understand the terms and conditions of this agreement and will fully participate in the implementation of the program and services described herein.

Insurance

VCOE and District each participate in the Ventura County Schools Self-Funding Authority (VCSSFA), and therefore collectively self-insure for worker's compensation, general liability, and property coverage under the VCSSFA self-insurance program.

Indemnification

VCOE and District each participate in the VCSSFA, and therefore collectively indemnify and defend the other for general liability coverage under the VCSSFA self-insurance program.

TUPE Tier 2 Consortium Grant 2020-2023

Authorized District Representative

Signature

Date

Authorized District Fiscal Representative

Signature

Date

Lisa Cline,

Lisa Cline

9-14-2020

VCOE Exec. Director Internal Business Services

Signature

Date

Dr. Antonio Castro,

[Signature]

2/28/20

VCOE Associate Superintendent

Signature

Date

~~010-5800-6695-0-8600-2100-000-240-3400-0 \$25,000.00~~

ENCUMBERED

09/15/2020 AL

[Signature] 9/18/2020

TOTALS

		Rio
		\$25,000.00
Student Services- \$175,000	010-5800-6695-0-8600-2100-000-240-3400-0	\$15,572.14
Family & Community Engagement- \$21,190	010-5800-6695-0-8600-2100-000-240-3401-0	\$1,885.56
Project Monitoring- \$45,407.55	010-5800-6695-0-8600-2100-000-240-3406-0	\$4,040.53
Tobacco Free- \$24,217	010-5800-6695-0-8600-2100-000-240-3405-0	\$2,154.92
Staff Professional Development- \$15,135.85	010-5800-6695-0-8600-2100-000-240-3402-0	\$1,346.85
Total		\$25,000.00

Exhibit B

A. Funding Restrictions

TUPE Grant funds are intended to supplement existing programs and must not be used to supplant other state or federal funds now being used for existing staff or activities. Grant funds cannot be transferred to any other program accounts that are for specific purposes other than tobacco-use prevention education, youth development, intervention, implementation or cessation/referral.

Funds may not be used for:

- a. Activities that supplant or duplicate existing TUPE programs or services funded by TUPE Program.
- b. Expenditures for land, buildings, and other intangible capital assets, including items acquired through leases with option to purchase and capitalized equipment costs in excess of \$5,000.
- c. Applicants are encouraged to review Procedure 770, Distinguishing between Supplies and Equipment, in the California School Accounting Manual (CSAM) for further discussion regarding capitalized equipment, noncapitalized equipment, and supplies. The CSAM can be downloaded from the CDE CSAM web page at <https://www.cde.ca.gov/fg/ac/sa/documents/csam2019complete.pdf>.
- d. Vaping and bullying detectors.
- e. Purchase of vehicles.
- f. Out-of-state travel.
- g. Food—exceptions may be allowed if the agency can provide a justification that the provision of food is necessary to implement a student strategy or other TUPE Program: Tier 2 Grant training event for students, staff, or parents conducted beyond normal school hours or off-site.
- h. Payment of any kind to law enforcement agencies for enforcement, lesson delivery, or other activities and services.
- i. Campus monitoring and supervision.
- j. Incentives in the form of cash or merchandise cards that can be used to purchase tobacco and nicotine products in any forms.
- k. Preparation, delivery, and travel costs associated with submitting this or subsequent TUPE applications.
- l. Child care—exceptions may be allowed if the agency can provide a justification that the child care is necessary to implement a meeting strategy or other TUPE Program Tier 2 training event for parents conducted beyond normal school hours or off site.

Exhibit B

- m. Reimbursement of costs incurred prior or beyond to the effective date of the Grant Agreement or considered unreasonable for the TUPE program.
- n. Reimbursement of costs that are currently covered by another TUPE grant or contract.
- o. Reimbursement of costs that are not consistent or allowable according to local and state guidelines or regulations.
- p. Reimbursement of costs in support of planning activities or preparation and submission of the grant application in response to the RFA.
- q. Reimbursement of any cost associated with the collection and/or disposal of any tobacco or e-cigarette delivery system waste.

B. Other Costs Requirements

- a. Student incentives, awards, and recognitions
 - i. Incentives are allowed to motivate and/or reinforce positive: behavior, participation, and/or involvement and should include educational items. These items must be directly related to tobacco-use prevention education.
 - ii. Incentives, when possible, should provide a tobacco-free message on the item.
 - iii. The use of incentives must be tied to an activity in the program plan and confirms that each recipient participated in the activity recommended for receipt. The budget justification must describe the activity required to receive the incentive.
 - iv. Total planned expenditures for all incentives, awards, and recognitions must not exceed 10 percent of the total grant award. Applicants are encouraged to review the LEA's policies regarding use of funds for such items.
 - v. The cost of the incentive, including gift cards, may not exceed \$25 in value, per person, per year, and shall not include merchandise or gift cards to locations that sell or promote the purchase of tobacco products.
 - vi. A log must be kept that includes, at a minimum, the recipient's name, item, dates of service, and how/where the incentive was distributed.
 - vii. Incentives, awards, and recognitions, including gift cards, can be used toward school purchases and cannot be in the form of cash or for individual or personal use.

Exhibit A-Rio TUPE Quarterly Expense Report 2020-2021

Object Code	Line Item	Amount Expended YTD	Current Year 1 Budget	QTR 1 EXPENSES 7/1/20 to 9/30/20 Due October 10, 2020	*REQUIRED * Expenditure Justification (Be Specific)	QTR 2 EXPENSES 10/1/20 to 12/31/20 Due January 10, 2021	*REQUIRED * Expenditure Justification (Be Specific)	QTR 3 EXPENSES 1/1/21 to 3/31/21 Due April 10, 2021	*REQUIRED * Expenditure Justification (Be Specific)	QTR 4 EXPENSES 4/1/21 to 6/30/21 Due June 20, 2021	*REQUIRED * Expenditure Justification (Be Specific)	REMAINING BALANCE GRANT END
1000	Certificated Salaries	\$0.00	\$25,000.00	\$0.00		\$0.00		\$0.00		\$0.00		\$25,000.00
	•District Coordinator	\$0.00										\$0.00
	•Site Coordinator	\$0.00										\$0.00
	•Youth Development Advisor	\$0.00										\$0.00
	• Substitute Teachers	\$0.00										\$0.00
2000	Classified Salaries	\$0.00	\$0.00	\$0.00		\$0.00		\$0.00		\$0.00		\$0.00
	•District Coordinator	\$0.00										\$0.00
	•Site Coordinator	\$0.00										\$0.00
	•Youth Development Advisor	\$0.00										\$0.00
3000	Employee Benefits	\$0.00	\$0.00	\$0.00		\$0.00		\$0.00		\$0.00		\$0.00
	•Certificated & Classified	\$0.00										\$0.00
4300	Materials & Supplies	\$0.00	\$0.00	\$0.00		\$0.00		\$0.00		\$0.00		\$0.00
	•General Office Supplies	\$0.00										\$0.00
	•Youth Development Supplies	\$0.00										\$0.00
5200	Travel	\$0.00	\$0.00	\$0.00		\$0.00		\$0.00		\$0.00		\$0.00
	•In-County Mileage	\$0.00										\$0.00
	•Youth Development Trainings	\$0.00										\$0.00
	•Youth Development Transportation	\$0.00										\$0.00
	TOTAL BUDGET & EXPENDITURES	\$0.00	\$25,000.00	\$0.00		\$0.00		\$0.00		\$0.00		\$25,000.00

Signature of Contractor Designee _____ Date _____



Agenda Item Details

Meeting	Oct 21, 2020 - RSD Regular Board Meeting
Category	9. Consent
Subject	9.9 Approval of Migrant Education Program MOU with VCOE
Access	Public
Type	Action (Consent)
Fiscal Impact	No
Budgeted	No
Budget Source	Not Applicable
Recommended Action	Staff recommends board approval of Migrant Education Program MOU.

Public Content

Speaker: Oscar Hernandez

Rationale:

Rio School District would like to renew the Migrant Education Program MOU with the Ventura County Office of Education for the 2020-21 school year.
Please see attached MOU for detailed information.

Migrant Mou 2020-21.pdf (63 KB)

Administrative Content

Executive Content

Our adopted rules of Parliamentary Procedure, Robert's Rules, provide for a consent agenda listing several items for approval of the Board by a single motion. Most of the items listed under the consent agenda have gone through Board subcommittee review and recommendation. Documentation concerning these items has been provided to all Board members and the public in advance to assure an extensive and thorough review. Items may be removed from the consent agenda at the request of any board member.

MEMORANDUM OF UNDERSTANDING
Between
Region 17, Migrant Education Program
Ventura County Office of Education
And
Rio Elementary School District
1800 Solar Drive
Oxnard, California 93030

This is an agreement to provide supplementary educational services for the Rio Elementary School District. This agreement is between the Ventura County Office of Education, Migrant Education Program, Region 17, hereinafter referred to as the Region and the Rio Elementary School District, hereinafter referred to as the District.

The period covered by this agreement shall be from July 1, 2020 to June 30, 2021 inclusive.

The Region agrees to:

- 1.0 Reimburse the District upon receipt of an invoice for any and all supplementary services provided to eligible migrant students and/or eligible migrant parents/guardians eligible to receive services as previously agreed and approved by the Region.
- 2.0 Verify eligibility of students and parents by an official State approved Certificate of Eligibility and/or a regional computer printout.
- 3.0 Provide any necessary training for the District staff, classified and/or certificated, working directly or indirectly with eligible migrant students and/or eligible migrant parents.
- 4.0 Provide a qualified Recruiter employed by the Region to identify and recruit all potential migrant students and/or parents.
- 5.0 Provide supervision and evaluation of the Recruiter in the performance of his/her duties.
- 6.0 Provide any necessary and relevant office supplies, materials, forms, and documents in the provision of the Migrant Education Program supplementary services.
- 7.0 Provide emergency health services to eligible migrant students as determined by the Region and deemed appropriate and necessary and providing there are sufficient and relevant health funds currently available.
- 8.0 Provide educational supplementary services to eligible migrant students in the areas of language arts, math, science, music, art, and any other relevant cultural, social, and educational activities provided in the State Core Standards, within the funds available and provided by the Region.
- 9.0 Provide supplementary educational services to Priority For Service and At-Risk Migrant Students Far Below Basic and Below Basic before serving Basic and Above migrant students, whenever possible.

The District agrees to:

- 1.0 Submit a monthly invoice with appropriate supportive documentation to the Region for reimbursement for all supplementary service costs provided to eligible migrant students and eligible migrant parents previously agreed and approved by the Region and the District jointly in writing.
- 2.0 Provide appropriate office space with desk, chair, phone, file cabinet, and any other relevant furniture and/or equipment relevant and necessary for the Recruiter to perform his/her duties.
- 3.0 Provide bus transportation to be charged to the Region for both the Region summer school program and the Region regular school year program.
- 4.0 Provide nutrition for both the Region summer school program and the Region regular school year program for eligible migrant students with any appropriate and relevant charges invoiced to the Region.
- 5.0 Provide custodial services for both the Region summer school program and the Region regular school year program with any appropriate and relevant charges invoiced to the Region.
- 6.0 Provide appropriate educational facilities for both the Region summer school program and the Region regular school year program.
- 7.0 Provide upon request by the Region the names, addresses and phone numbers of district students and/or parents in order for the Region to determine eligibility in the Migrant Education Program.

TERMINATION:

Either party, in writing, may terminate this MOU at any time upon 30 days' written notice to the other Party.

REVISION/AMENDMENT:

This MOU may be revised and/or amended by mutual agreement of both parties at any time during the duration of the agreement.

IDEMNIFICATION/HOLD HARMLESS:

Each party agrees that it will indemnify, hold harmless and defend the other party, its officers, employees, and agents, from all claims, losses and damages, including property damage, personal injury, death, attorney fees and liability of every kind, directly or indirectly arising from the negligent acts or omissions, or willful misconduct, of that party.

The parties have evidenced their acceptance of this Memorandum of Understanding by their signatures affixed below.

Rio Elementary School District
1800 Solar Drive
Oxnard, California 93030

Ventura County Office of Education
5189 Verdugo Way
Camarillo, California 93012

By: _____
Signature Superintendent or Designee

By: _____
Signature Superintendent or Designee

Print Name

Print Name

Print Title

Print Title

Date

Date

9.10



Agenda Item Details

Meeting	Oct 21, 2020 - RSD Regular Board Meeting
Category	9. Consent
Subject	9.10 Preschool Services Contract with Catalyst (Formerly CDI)
Access	Public
Type	Action (Consent)
Fiscal Impact	No
Budgeted	No
Budget Source	Not applicable
Recommended Action	Staff recommends board approval of Catalyst contract.

Public Content

Speaker: Oscar Hernandez

Rationale:

Making preschool available to children living within the boundaries of the Rio School District allows for the social and academic development of students who will enroll in the Rio School District. In 19-20, Catalyst provided preschool opportunities at three RSD schools- Rio del Mar, Rio del Norte, and Rio Real- for a total of 54 full-day slots, 144 half-day slots, and 30 after school care slots (K-2 at Rio Real only) throughout the district.

[Rio SD 2020-21 Lease CDI.pdf \(114 KB\)](#)

Administrative Content

Executive Content

Our adopted rules of Parliamentary Procedure, Robert's Rules, provide for a consent agenda listing several items for approval of the Board by a single motion. Most of the items listed under the consent agenda have gone through Board subcommittee review and recommendation. Documentation concerning these items has been provided to all Board members and the public in advance to assure an extensive and thorough review. Items may be removed from the consent agenda at the request of any board member.

**CATALYST FAMILY INCORPORATED
LEASE AGREEMENT**

This is an agreement between the **Rio School District**, hereinafter referred to as **DISTRICT**, and Catalyst Family Incorporated, hereinafter referred to as **CATALYST FAMILY INC**. The parties hereto agree as follows:

1. **TERM.** The term of this agreement shall commence on October 1, 2020, and shall continue through June 30, 2021, during which time the CONTRACTOR shall perform the services required under this agreement.
2. **SERVICE PROVISIONS.**
 - 2.1 Program Description
 - 2.2 Program Goal
 - 2.3 Activities and Service with outcomes and measurement instruments.
3. **FACILITIES AND CUSTODIAL COST.** SUBCONTRACTOR will contract and/or provide its own custodial services. DISTRICT will not bill SUBCONTRACTOR for expenses to help cover facilities and custodial costs incurred by the District
4. **RENT.** SUBCONTRACTOR shall pay to the DISTRICT the total for rent for the lease term of One dollar (\$1.00) per year payable annually on or before August 1, 2020. The difference between the actual value of the property and the \$1.00 rent will be used as an In-Kind donation. The Rio School District will provide SUBCONTRACTOR with a value statement indicating the actual value of the classroom being utilized
5. **INVESTIGATION AND RESEARCH.** SUBCONTRACTOR by investigation and research has acquired reasonable knowledge of all conditions affecting the work to be done and labor and material needed, and the execution of this contract is to be based upon such investigation and research, and not upon any representation made by the DISTRICT, any of its offices, or employees, except as provided herein.
6. **SUBCONTRACTOR.** No relationship of employer and employee is created in this agreement, it being understood that the SUBCONTRACTOR is a SUBCONTRACTOR. None of the persons performing services for SUBCONTRACTOR pursuant to this agreement, whether said person is a member, partner, employee, contractor, or otherwise, shall have any claim under this agreement or otherwise against DISTRICT for sick leave, vacation pay, retirement benefits, social security, workers' compensation, disability, unemployment insurance benefits, or employee benefits of any kind.

DISTRICT is not required to make any deductions for any third party from the compensation payable to SUBCONTRACTOR under the provisions of this agreement. SUBCONTRACTOR hereby holds DISTRICT harmless from any and all claims that may be made against DISTRICT based upon any contention by any third party that any employer-employee relationship exists by reason of this agreement.

It is further understood and agreed by the parties hereto that SUBCONTRACTOR in the performance of its obligation hereby is subject to the control of director of DISTRICT only as to the results to be accomplished by the services hereunder agreed to be rendered and performed and not to the means and methods for accomplishing the results.

If, in the performance of this agreement, any third persons are employed by the SUBCONTRACTOR, such persons shall be entirely and exclusively under direction, supervision, and control of the SUBCONTRACTOR. All terms of employment, including hours, wages, working conditions, discipline, hiring and discharging or any other terms of employment or requirements of law, shall be determined by SUBCONTRACTOR and comply with all statutory requirements.

7. **CONTRACTOR'S EMPLOYEES.** SUBCONTRACTOR agrees that all SUBCONTRACTOR employees have secured or shall secure at SUBCONTRACTOR's own expense all persons and employees and that all such services shall be performed by SUBCONTRACTOR or under SUBCONTRACTOR's supervision by persons authorized by law to perform such services.
8. **EQUIPMENT.** Equipment required to perform the services required under this Agreement will be provided by the DISTRICT and remain the property of the DISTRICT.
9. **EQUAL OPPORTUNITY.** SUBCONTRACTOR will not discriminate against any employee, or against any applicant for such employment because of age, race, color, religion, physical handicap, ancestry, gender, or national origin. This provision shall include, but not limited to, the following: employment, upgrading, demotion, or transfer, recruitment or recruitment advertising, layoff or termination; rates of pay or other forms of compensation; and selection for training, including apprenticeship.
10. **PERSONNEL DISCLOSURE.** SUBCONTRACTOR shall make available to DISTRICT a current list of all personnel providing services under this agreement. Changes to this list shall be immediately provided to DISTRICT in writing. The list shall include: (1) all full or part time staff positions by title, including volunteer positions whose direct services are required to provide the services described herein, (2) a brief description of the functions of each such position and the hours each position works each week or, for part-time positions, each day or month, as appropriate, (3) the professional degree, if applicable, and experience required for each position, and (4) the name of the person responsible for fulfilling the terms of this agreement.
11. **RESPONSIBILITY FOR EQUIPMENT.** DISTRICT shall not be responsible nor held liable for any damage to person or property consequent upon the use, misuse, or failure of any equipment used by SUBCONTRACTOR or any of SUBCONTRACTOR's employees, even though such equipment is furnished, rented, or loaned to SUBCONTRACTOR by DISTRICT. The acceptance or use of any such equipment by SUBCONTRACTOR or SUBCONTRACTOR's employees shall be construed to mean

that SUBCONTRACTOR accepts full responsibility for and agrees to exonerate, indemnify and hold harmless DISTRICT from and against any and all claims for any damage whatsoever resulting from the use, misuse, or failure of such equipment.

12. **INDEMNIFICATION AND HOLD HARMLESS.** All activities and work covered by this Agreement shall be at the risk of the SUBCONTRACTOR. SUBCONTRACTOR agrees to defend, indemnify and hold harmless the DISTRICT, including all of its committee members, employees, agents and volunteers against any and all claims or lawsuits, judgments, debts, demands and liability whether against SUBCONTRACTOR, DISTRICT or others, including those arising from injuries or death of persons and for damages to property, arising directly or indirectly out of the obligations herein described or undertaken or out of operations conducted or subsidized in whole or in part by SUBCONTRACTOR, save and except claims or litigation arising through the negligence or wrongdoing, or the willful misconduct of the DISTRICT.

13. **INSURANCE.** SUBCONTRACTOR at its sole cost and expense, shall obtain and maintain in full force during the term of this agreement the following types of insurance.

13.1 Commercial General Liability "occurrence" coverage in the minimum amount of \$1,000,000 combined single limit (CSL) bodily injury and property damage each occurrence and \$1,000,000 aggregate, including personal injury, broad form property damage, products/completed operations, broad form blanket contractual, and \$50,000 fire legal liability, if applicable.

13.2 Commercial Automobile Liability coverage in the minimum amount of \$1,000,000 CSL bodily injury and property damage, including owned, non-owned and hired automobiles.

13.3 Workers' Compensation coverage in full compliance with California Statutory Requirements for all employees of the SUBCONTRACTOR and Employer's Liability in the minimum amount of \$1,000,000.

13.4 Professional Liability coverage in the minimum amount of \$1,000,000 each occurrence and in the aggregate.

13.5 All insurance required under this agreement shall be primary coverage as respects to the DISTRICT, and any insurance or self-insurance maintained by the DISTRICT shall be in excess of the SUBCONTRACTOR's insurance coverage and shall not contribute to the SUBCONTRACTOR's coverage. DISTRICT is to be notified immediately if any aggregate insurance limit is exceeded. Additional coverage must be purchased to meet requirements.

13.6 The DISTRICT is to be named as ADDITIONAL INSURED as respects to work done by SUBCONTRACTOR under the terms of this agreement on all policies required. However, this paragraph 2.7.3 shall not be construed to apply to Workers' Compensation coverage.

13.7 Policies shall not be cancelled, non-renewed or reduced in scope of coverage until after sixty (60) days written notice has been given to the DISTRICT.

13.8 SUBCONTRACTOR agrees to provide DISTRICT with the following insurance documents within fourteen (14) days after the execution of this agreement.

13.8.1 Certificates of Insurance for coverage required under this agreement.

13.8.2 Additional insured endorsements; and

13.8.3 Sixty (60) days Notice of Cancellation Clause endorsements except for nonpayment of premium

13.9 Failure to timely provide these documents shall be grounds for immediate termination or suspension of this agreement.

13.10 It is the responsibility of the SUBCONTRACTOR to confirm that all terms and conditions of the insurance provisions are complied with any and all subcontractors that the SUBCONTRACTOR may use for the completion of this agreement.

13.11 Insurance coverage in the minimum amounts set forth herein shall not be construed to relieve the SUBCONTRACTOR for liability in excess of such coverage, nor shall it preclude the DISTRICT from taking such other actions as are available to it under any other provisions of this agreement or otherwise in law.

13.12 If the Professional Liability Coverage is "claims made," SUBCONTRACTOR must, for a period of three (3) years after the date when the agreement is terminated, completed, or non-renewed, maintain insurance with a retroactive date that is on or before the start date of the agreement services or purchase an extended reporting period endorsement (tail coverage). DISTRICT may withhold final payments due until SUBCONTRACTOR provides satisfactory evidence of the tail coverage to DISTRICT.

14. **ASSIGN ABILITY.** SUBCONTRACTOR shall not assign any interest in this agreement, and shall not transfer any interest in the same, whether by assignment or novation, without the prior written consent of DISTRICT thereto; provided, however, that claims for money due or to become due to SUBCONTRACTOR from DISTRICT under this agreement may be assigned without such approval. Notice of any such assignment or transfer shall be furnished promptly to DISTRICT.

15. **SUBCONTRACTS.** Functions undertaken by the SUBCONTRACTOR may be carried out under subcontracts. However, SUBCONTRACTOR may not delegate its duties or obligations nor assign its rights hereunder, either in whole or in part, without prior written consent of DISTRICT. Any such attempted delegation or assignment without prior consent shall be void. Any change whatsoever in the corporate structure of SUBCONTRACTOR or the transfer of assets in excess of ten (10) percent of the total assets of SUBCONTRACTOR shall be deemed an assignment of benefits under the terms of this agreement requiring DISTRICT approval.

All subcontracts shall be in writing and copies provided to DISTRICT. No subcontract shall alter in any way any legal responsibility of SUBCONTRACTOR to DISTRICT. All subcontractors will be provided a copy of this agreement, and any subcontract must state that any work performed must be consistent with this agreement. DISTRICT has the right to refuse reimbursement for obligations incurred under any subcontract, which do not comply with the terms of this agreement.

In each subcontract, SUBCONTRACTOR shall include all provisions that the DISTRICT may require. DISTRICT shall make these provisions available to SUBCONTRACTOR.

16. **POLITICAL ACTIVITIES PROHIBITED.** None of the funds, provided directly or indirectly, under this agreement shall be used for any political activities or to further the election or defeat of any candidate for public office. Neither the contract nor any funds provided hereunder shall be utilized in support of any partisan political activities, or activities for or against the election of a candidate for an elected office.
17. **RELIGIOUS ACTIVITIES PROHIBITED.** There shall be no religious worship, instructions or proselytization as part of, or in connection with the performance of this agreement. Active participation in religious worship or instruction cannot be a prerequisite for individuals receiving services utilizing Proposition 10 dollars. Expenditures of Proposition 10 dollars for religious services and practices are specifically prohibited. SUBCONTRACTOR must indicate how unlawful expenditures of Proposition 10 dollars for religious services and practices are to be avoided. Any religious indoctrination or encouragement incidental to the delivery of services under the application is strictly prohibited.
18. **LICENSES AND STANDARDS.** SUBCONTRACTOR shall conform with all federal, state, county and local rules and regulations, including facility and professional licensing and certification laws and shall keep in effect any and all licenses, permits, notices and certificates as are required for the duration of this agreement. SUBCONTRACTOR shall further comply with all laws applicable to wages and hours of employment, occupational safety, and fire safety, health and sanitation.

In the performance of this agreement, SUBCONTRACTOR shall comply with all applicable provisions of the California Welfare and Institutions Code, Title 45 of the Code of Federal Regulations, all applicable laws and regulations of the United States, State of California, and DISTRICT and all administrative regulations, rules and policies adopted hereunder that are applicable as identified by the scope of this agreement as each and all may now exist or be hereinafter amended or changed. In addition, SUBCONTRACTOR shall comply with all rules and regulations set forth in Federal Office of Management and Budget (OMB) Circular A-122 (cost principles for nonprofit organizations) or OMB Circular A-21 (cost principles for educational institutions) or OMB Circular A-87 (cost principles for state and local governments) as applicable to form of entity by which SUBCONTRACTOR transacts its business.

19. **MAINTENANCE OF RECORDS.** SUBCONTRACTOR agrees to maintain all records pertaining to service delivery and fiscal and administrative control for five (5) years after final payment has been made, or until all pending DISTRICT, state, or federal audits are completed, whichever is later. Upon request, SUBCONTRACTOR shall make these records available within Ventura County to all authorized DISTRICT, state (including Auditor General) and federal personnel.
20. **CUSTODY OF RECORDS.** At its option, DISTRICT may take custody of SUBCONTRACTOR's client records related to services provided under this agreement upon agreement termination. DISTRICT agrees that such custody shall conform to applicable confidentiality provisions of state and federal law. Said records shall be kept by DISTRICT in an accessible location within Ventura County and shall be available to SUBCONTRACTOR for examination and inspection.
21. **FISCAL AND PERFORMANCE AUDITS AND INSPECTION OF RECORDS.** Authorized federal, state, or county representatives shall have the right to monitor, assess, or evaluate SUBCONTRACTOR's performance in accordance with federal and state laws and regulations. The monitoring, assessments, or evaluations may include but are not limited to audits, inspection of premises, reports, and interviews of program staff and participants.

At any time during normal business hours, and as often as DISTRICT may deem necessary, SUBCONTRACTOR shall make available to DISTRICT, state, federal or county officials for examination, all records pertaining to all matters covered by this agreement and shall permit county, state or federal officials to audit, examine and make excerpts or transcripts from such records, and to make audits of all invoices, materials, payrolls, records of personnel, information regarding clients receiving services, and other data relating to all matters covered by this agreement.

22. DISTRICT shall have the right to review the work being performed by the SUBCONTRACTOR under this contract at any time during DISTRICT's usual working hours. Review, checking, approval or other action by DISTRICT shall not relieve SUBCONTRACTOR of SUBCONTRACTOR's responsibility for the accuracy and completeness of the work performed under this contract.
23. **CHILD ABUSE REPORTING.** SUBCONTRACTOR shall require all employees, volunteers, SUBCONTRACTORS, or agents performing services under this agreement who are required by Section 11166, Subdivision (a), of the Penal Code to report child abuse or neglect or are required by Section 15630 of the Welfare and Institutions Code to report elder or dependent adult abuse or neglect, to sign a statement that he or she understands the reporting requirements and will comply with them.
- 22.1 SUBCONTRACTOR shall establish procedures to ensure the reporting of child abuse and neglect and elder or dependent adult abuse and neglect by all employees, volunteers, SUBCONTRACTOR's, or agents who gain knowledge of, or reasonably suspect that a child, elder or dependent adult has been a victim of abuse or neglect, even when such persons are **not** otherwise required by Section 11166, Subdivision (a), of the

Penal Code or Section 15630 of the Welfare and Institutions Code, to report such abuse or neglect.

24. **TERMINATION. TERMINATION.** DISTR[CT retains the right to terminate this contract for any reason prior to completion by notifying SUBCONTRACTOR in writing and by paying charges accumulated prior to such termination. On completion or termination of contract, DISTRICT shall be entitled to immediate possession of and SUBCONTRACTOR shall furnish all computations, programs, correspondence and other pertinent data gathered or computed by SUBCONTRACTOR for this particular project prior to any termination. SUBCONTRACTOR hereby expressly waives any and all claims for damages or compensation arising under this contract, except as set forth in this paragraph, in the event of such termination.
25. **ADDENDA.** DISTRICT may from time to time require changes in the scope of the services required hereunder. Such changes, including any increase or decrease in the amount of SUBCONTRACTOR's compensation which are mutually agreed upon by and between DISTRICT and SUBCONTRACTOR, shall be effective when incorporated in written amendments to this agreement.
26. **CONFLICT OF INTEREST.** SUBCONTRACTOR covenants that SUBCONTRACTOR presently has no interest, including, but not limited to, other projects or independent contracts, and shall not acquire any such interest, direct or indirect, which would conflict in any manner or degree with the performance of services required to be performed under this agreement. SUBCONTRACTOR further covenants that in the performance of this agreement, no person having such interest shall be employed or retained by SUBCONTRACTOR under this agreement.
27. **CONFIDENTIALITY.** Any reports, information, data, statistics, forms, procedures, systems, studies, and any other communication or form of knowledge given to or prepared or assembled by SUBCONTRACTOR under this agreement in which the DISTRICT requires to be kept as confidential shall not be made available to any individual or organization by SUBCONTRACTOR without the prior written approval of DISTRICT, except as authorized by law. SUBCONTRACTOR shall insure that SUBCONTRACTOR's employees and/or independent SUB-CONTRACTOR or agents shall keep such confidential information confidential.

28. **NOTICES.** All notices made under this agreement shall be made in writing and addressed or delivered as follows:

TO DISTRICT: Rio School District
Attn: Sonya Lopez Mercado
2500 Vineyard Avenue
Oxnard, CA 93036
(805) 485-3111

SUBCONTRACTOR: Catalyst Family Incorporated
350 Woodview Ave., Suite 100
Morgan Hill, CA 95037
(916) 830-3342

Either party may, by written notice to the other, change its own mailing address, and shall promptly notify the other party in writing.

29. **ENTIRE AGREEMENT.** The terms and conditions set forth in the attached exhibits hereto are incorporated herein by this reference. This agreement contains all terms and conditions agreed upon by DISTRICT and SUBCONTRACTOR and no other understanding, oral or otherwise, regarding this agreement shall be deemed to bind any of the parties of this agreement.

IN WITNESS THEREOF, DISTRICT and SUBCONTRACTOR have executed this agreement on the dates indicated below.

DISTRICT

CATALYST FAMILY INC.

John D. Puglisi

Ph.D. Superintendent

Susan Dumars

President

Date

Date

CATALYST FAMILY INCORPORATED SUBCONTRACT ADDENDA

This is an “Amendment” to the original agreement between the **Rio School District**, hereinafter referred to as **DISTRICT**, and **Catalyst Family Incorporated**, hereinafter referred to as **SUBCONTRACTOR**.

Coronavirus disease 2019 (COVID-19) is a respiratory illness that can spread from person to person. The parties enter into the following agreement in response to ongoing health concerns presented by the COVID-19 virus:

1. The parties will communicate updated policies within each organization as they are developed and distributed.
2. Clear communication will be sent to the school district if an employee or child has tested positive for COVID-19.
3. SUBCONTRACTOR agrees to adhere to all state and federal COVID-19 return to work protocols.
4. SUBCONTRACTOR will implement the following protocols and procedures to ensure the health and safety of children and employees

Health Screening for Children and Staff:

- Temperature of anyone who enters the facility is taken upon arrival.
- Temperature log indicates “Yes” or “No” for a high temperature
- Families and staff are asked if they have been exposed to COVID-19, daily.
- Any child or staff member that shows signs of illness is immediately sent home.

Parent Sign in and Out Procedures:

- Parents sign in and out outside of the facility using their own pen or a disinfected pen provided by the site.
- Parents do not enter the classroom and are met by staff at the sign in/out gate

Face Coverings:

- Face coverings are required for adults at all times. Six feet of social distancing is also maintained with other adults at all times
- For children over the ages of two, face coverings are recommended when they are not able to maintain 6-foot physical distancing from both adults and children.
- Mask and/or face shields may also be worn. Face coverings are strongly encouraged for young children between two years old and second grade, if they can be worn properly. A face shield is an acceptable alternative for children in this cohort.
- Face coverings are worn by children in 3rd grade and above

Sanitizing and Disinfecting Protocols:

- Staff clean high touch areas hourly or in-between use.

- Children and staff restrooms are disinfected hourly. Restrooms shared by more than one stable group of children and/or person are disinfected in-between use.
- Signage of protocols in English and Spanish will be posted on the preschool gate near the parking lot

Program adjustments for children:

- Children have their own materials that they keep in their own container.
- Any shared material is disinfected after each use.
- Increase of outdoor learning and enrichment experiences
- Daily discussions about healthy behaviors and practices.
- Provide families with videos and written information with COVID- 19 facts.
- Complete weekly check-ins with families who are not able to attend.
- Maximum of 12 children in each Preschool and School-Age classroom
- Increased individual play and parallel play when engaging in conversation
- Increased non-touch outdoor activities with equipment disinfected after each use

Food Service:

- Meals will continue to be provided by Rio School District
- Family style service will be suspended and substituted with individualized meal service as per USDA and people will sit 6 feet apart of one another.

5. HOURS OF OPERATION

Monday-Friday, 7:00am-6:00pm

6. REOPENING PLANS.

SUBCONTRACTOR will pilot a reopening at the Rio Real School while DISTRICT is involved in distance learning. The center will have one Preschool classroom and one School-Age classroom. This program provides full-day child care for working families and supports with distance learning. Enrollment for the School-Age program will be provided to the lowest income families first, then to families who have been enrolled the longest. Enrollment for the Preschool program will be provided to the lowest income four-year-olds, then to the lowest income three-year-olds.

Once DISTRICT students return to campus, SUBCONTRACTOR will return to remaining sites at Rio del Norte Elementary and Rio Del Mar School.

If DISTRICT extends distance learning, SUBCONTRACTOR may reopen one site at a time. Communication regarding COVID data will be provided to DISTRICT on a consistent basis.

SUBCONTRACTOR will collaborate with site administrators of DISTRICT on ingress and egress of the Preschool program.

DISTRICT

CATALYST FAMILY INC.

John D. Puglisi

Ph.D. Superintendent

Susan Dumars

President

Date

Date

Areas	Before Each Use	After Each Use	Daily-End of Day	Weekly	Comments
Food Preparation Surfaces	Clean & Sanitize	Clean & Sanitize			Use Oxivir-Tb or EPA registered household Surfaces Sanitize bleach at ½ teaspoon /1 qt cool water. If using Oxivir Tb, all food contact surfaces must be rinsed with potable water
Eating Utensils & Dishes		Clean & Sanitize			Use 5 Step Method or a dishwasher
Tables Used during meal time and highchair trays	Clean & Sanitize	Clean & Sanitize			Use Oxivir-Tb or EPA registered household bleach at ½ teaspoon/1 qt cool water. If using Oxivir-Tb, all food contact surfaces must be rinsed with potable water
Countertops where food is prepared	Clean & Sanitize	Clean & Sanitize			See Above
Refrigerator				Clean	Clean spills as they occur.
Microwave /stove				Clean	Clean spills as they occur.
Play Areas in classroom-All horizontal surfaces			Clean		All horizontal surfaces should be cleaned daily by janitorial services. When this does not occur, staff need to clean surface with a soap and water solution (not a sanitizer or disinfectant).
Computer keyboards mouse			Clean & Disinfect		Spray Oxivir-Tb onto paper first.
Door & Cabinet handles/phones			Clean & Disinfect		

<p>Bathroom sinks used to wash hands before meals</p>	<p>Clean & Disinfect before meal time handwashing</p>	<p>Clean & Disinfect</p>	<p>Bathroom sinks harbor many germs. To prevent cross contamination when washing hands prior to meal time, the sink and faucets must be disinfected for 1 minute using Oxivir-Tb and then rinsed with water.</p>
<p>Areas</p>	<p>Before Each Use</p>	<p>After Each Use</p>	<p>Daily-End of Day Weekly Comments</p>
<p>Kitchen sink also used for handwashing</p>	<p>Clean & Disinfect before food prep</p>	<p>Clean & Disinfect</p>	<p>Before using the kitchen sink to wash dishes, rinse fruits/vegetables or for any other foodprep, the sink must be disinfected for 1 minute using Oxivir-TB and then rinsed with water.</p>
<p>Dramatic play clothes</p>			<p>Laundry</p>
<p>Plastic Mouthed toys</p>	<p>Remove from play area</p>	<p>Clean & Sanitize</p>	<p>Sanitize using EPA registered regular household bleach ½ teaspoon/1 qt cool water</p>
<p>Machine Washable Cloth Toys</p>			<p>Laundry</p>
<p>Changing Table</p>	<p>Clean & Disinfect</p>	<p>Clean & Disinfect under pad</p>	<p>Use Oxivir-Tb to clean and disinfect after each use. 1 minute contact time on surface. At the end of the day, the surface beneath the changing table pad is cleaned and sanitized.</p>
<p>Potty Chairs</p>	<p>Clean & Disinfect</p>		<p>Use Oxivir-Tb to clean and disinfect after each use. 1 minute contact time on surface.</p>
<p>Bed Sheets, Pillow Cases, Blankets</p>			<p>Laundry before use by another child</p>
<p>Cots & Mats</p>			<p>Clean before use by another child</p>
<p>Drinking Fountains</p>	<p>Clean & Disinfect</p>		<p>Drinking fountains used exclusively for CDI-CDC Children are cleaned and disinfected daily.</p>



Cleaning, Sanitizing, and **Disinfecting Schedule**

9.11



Agenda Item Details

Meeting	Oct 21, 2020 - RSD Regular Board Meeting
Category	9. Consent
Subject	9.11 Preschool Services Contract with Child Development Resources of Ventura County
Access	Public
Type	Action (Consent)
Fiscal Impact	No
Budgeted	No
Budget Source	Not applicable
Recommended Action	Staff recommends board approval of CDR contract.

Public Content

Speaker: Oscar Hernandez

Rationale:

Making preschool available to children living within the boundaries of the Rio School District allows for the social and academic development of students who may enroll in the Rio School District.

In 19-20, Child Development Resources provided preschool opportunities at three RSD schools- Rio Lindo, Rio Plaza, and Rio Rosales. This agreement would allow them to continue to provide early education opportunities at Rio Plaza and Rio Rosales in person during the 20-21 school year once all Rio School District students return to in-person instruction for hybrid learning. The Rio Lindo agreement remains separate.

[RIO LINDO_Signed and Approved Lease Agreement and MOU_Expires 6.30.2024.pdf \(572 KB\)](#)

[RIO SCHOOL DISTRICT LEASE AGREEMENT_Amendment Rio Lindo for COVID-19.pdf \(287 KB\)](#)

[RIO SCHOOL DISTRICT LEASE AGREEMENT_Amendment Rio Plaza and Rio Rosales for COVID-19.pdf \(285 KB\)](#)

[CDR LEASE AGREEMENT RIO 20-21_Rio Plaza and Rio Rosales_.pdf \(591 KB\)](#)

[CDR-Rio District MOU 20-21 RIo Plaza and Rio Rosales.pdf \(151 KB\)](#)

[Universal Precautions Procedure for COVID19 - Site Specific.pdf \(756 KB\)](#)

Administrative Content**Executive Content**

Our adopted rules of Parliamentary Procedure, Robert's Rules, provide for a consent agenda listing several items for approval of the Board by a single motion. Most of the items listed under the consent agenda have gone through Board subcommittee review and recommendation. Documentation concerning these items has been provided to all Board members and the public in advance to assure an extensive and thorough review. Items may be removed from the consent agenda at the request of any board member.

LEASE AGREEMENT

THIS LEASE AGREEMENT executed on the 1st day of July 2019 by and between Rio School District hereinafter called DISTRICT and Child Development Resources of Ventura County, Inc. hereinafter called CDR.

OFFER TO RENT

DISTRICT hereby rents to CDR, subject to the following terms and conditions of this Agreement, the premises at the Rio Lindo Elementary School in Oxnard, CA to be occupied as Head Start/State Preschool classrooms and for no other purpose.

TERM

The term of this agreement shall be for five-years beginning July 1, 2019, and ending on June 30, 2024, and can be extended for an additional 5-year period, running July 1 thru June 30, if parties mutually agree and classroom space is available for use by CDR. As a safety precaution, if classroom space is not available in the future, and the classroom is needed Rio School District will give CDR a one-year notice.

USE

CDR shall use the leased space for the purpose of a Head Start/State Preschool Program and uses incidental thereto. Such use shall be conducted in a manner that does not disrupt the DISTRICT's existing activities on the premises.

TERMINATION OF LEASE

The lease runs for the full term as specified above. The only exception is in the event classroom space is no longer available. Either party shall notify the other in writing at least 30 days prior to vacating the premises, or in the case of the DISTRICT if the classroom is no longer available.

RENT

CDR shall pay to the DISTRICT the total for rent for the lease term of One dollar (\$1.00) per year payable annually on or before August 1, 2019. The difference between the actual value of the property and the \$1.00 rent will be used as an In-Kind donation. The Rio School District will provide CDR with a value statement indicating the actual value of the classroom being utilized.

FACILITIES AND CUSTODIAL COST.

DISTRICT will bill CDR for the usage of each classroom utilized at Rio Plaza Elementary School, Rio Rosales Elementary School and Rio Lindo Elementary School in the amount of two hundred eighty-four dollars (\$284.00) per month/per classroom to help cover facilities and custodial costs.

If District janitorial service does not meet lessee's standards as mandated by Community Care Licensing (CCL), subjecting lessee to a citation by CCL, Lessee will reserve the right to have the violation corrected immediately by outside vendor at lessee's discretion.

POSSESSION

CDR has examined and knows the condition of the property and by taking possession acknowledges that they have received the same in good order and condition except as herein otherwise stated.

RIGHT OF ENTRY

DISTRICT shall have the right to enter the classroom at any time in order to inspect the premises, make necessary repairs, alterations or improvements, to supply services as agreed or for any reasonable purpose.

MAINTENANCE, REPAIRS OR ALTERATIONS

CDR may not make any alterations to the leased premises without the consent in writing of the DISTRICT. DISTRICT will provide custodial services five (5) days per week (Monday through Friday, excluding Rio School Board approved holidays and non-school days) and maintenance services when needed while the Head Start/State Preschool is operational at the school sites mentioned above.

When scheduling work to be completed on Lessor's campuses, especially during District vacation or non-school days, The Lessor must notify CDR of any possible interruption of calendar days for CDR's programs. CDR is required to provide services for an established number of days per year. Proper notice must be given to parents to find alternative care for their children.

OPERATION ON NON-SCHOOL DAYS

CDR will incur the cost for facilities support that is requested on non-Rio School District classified contract days, weekends and Rio School District Board approved holidays and non-school days. This will include special events or regular services. Listed below are the 31 Rio School District Board approved holidays and non-school days for the 2019-2020 academic calendar. The Rio School District calendar is subject to change. District staff will inform CDR in a timely manner of any changes.

- September 2
- November 11, 18, 19, 20, 21, 22
- December 23, 24, 25, 26, 27, 30, 31
- January 1, 2, 3, 20
- February 3, 17
- April 6, 7, 8, 9, 10, 13, 14, 15, 16, 17,
- May 25

INDEMNIFICATION

DISTRICT shall not be liable for any damage or injury to CDR, or any other person, or to any property, occurring on the premises, or any part thereof, or in common areas thereof, and CDR agrees to hold DISTRICT harmless from any claims or damages unless caused solely by DISTRICT's negligence.

CDR shall not be liable for any damages or injury to DISTRICT, or any other person, or to any property, occurring on the premises, or any part thereof, or in common areas thereof, and DISTRICT agrees to hold CDR harmless from any claims or damages unless caused solely by CDR's negligence.

COVENANTS

The covenants and conditions herein contained shall apply to and bind the legal representatives and assigns of the parties hereto, and all covenants are to be construed as conditions of the Agreement.

OCCUPANTS

CDR agrees to provide qualified bilingual (Spanish/English) instructional staff to serve a minimum of 40 children in an extended day program (6 Hours). The facilities will be used Monday through Fridays, except Holidays.

NOTICES

Any notice which either party may require to give may be given by mailing the same, by registered mail to the addresses set forth following the signatures.

SPECIAL PROVISIONS

See the attached Memorandum of Understanding between CDR and the DISTRICT dated July 1, 2019, which defines the terms and conditions of this agreement.

ENTIRE AGREEMENT

The terms and conditions of the Agreement, together with the MOU are the entire agreement and understanding of the parties. BOTH PARTIES acknowledge that they have read this Agreement and understand its provisions and agree to occupy said premises under the terms of the Agreement. In witness, the parties have executed this agreement on the day and year written below:

Lessor:



John D. Puglisi, Ph.D., Superintendent

6/27/19
Date

Rio School District

2500 Vineyard Ave.
Oxnard, CA 93036

Lessee:

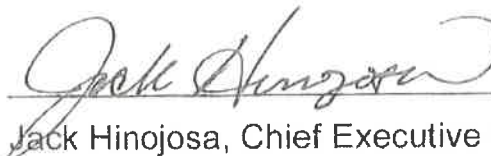

Jack Hinojosa, Chief Executive Officer

6/17/19
Date

**Child Development Resources of Ventura County, Inc.
Head Start/State Preschool Program**

221 Ventura Boulevard
Oxnard, CA 93036-0277

Memorandum of Understanding

**Rio School District
&**

Child Development Resources of Ventura County, Inc. Head Start/State Preschool

This Memorandum of Understanding (MOU) explains and confirms the agreement between Rio School District and Child Development Resources of Ventura County, Inc. Head Start/State Preschool program (CDR). These agencies agree to collaborate in the development and implementation of Head Start/State Preschool classes in the Rio School District, at Rio Lindo.

Memorandum of Understanding Purpose:

This Memorandum of Understanding is to confirm an effective and collaborative working relationship between the parties named above. The purpose of this collaborative partnership will be to provide preschool educational services to eligible children. The Rio School District and CDR will work cooperatively to provide a high-quality preschool program, at Rio Lindo which will serve children three to five years of age. To ensure the opportunity for enrollment of children and families that reside within the boundaries of Rio Lindo, CDR Head Start staff will canvass neighborhoods door to door.

Memorandum of Understanding Timeline:

This Memorandum of Understanding will be in effect from July 1, 2019 through June 30, 2024, and can be extended for an additional 5 year period, running July 1 thru June 30, if parties mutually agree and classroom space is available for use by CDR. If classroom space is not available on site, notice shall be given in writing by February 28th, prior to the start of a new school year, to avoid the displacement of children.

Memorandum of Understanding Agreement and Description of Services:

The Rio School District agrees to:

1. Work in partnership with CDR on the organization and management of the installation of the Rio Lindo playground.
2. CDR maintenance staff to remain responsible for the playground equipment and the playground surface materials.
3. Provide two portable classrooms at Rio Lindo to house a Head Start federally funded program and/or a State Preschool Funded Program, which will serve a minimum of 40 preschool age children in an extended day program (6 hours).
4. Provide custodial services five-days per week Monday through Friday, (excluding Rio School Board approved holidays and non-school days) and

Memorandum of Understanding

Rio School District & Child Development Resources of Ventura County, Inc. Head Start/State Preschool

- facility maintenance services as needed when the Head Start/State Preschool Programs are in operation at Rio Lindo.
5. Notify CDR when a facility is locked down for security purposes.
 6. Notify CDR when a facility will not have access to utilities or if utilities need to be turned off, as a result of an emergency, so that CDR staff can contact families of our students in a timely manner.
 7. Allow use of our classroom space for evening monthly parent involvement activities such as parent meetings and educational workshops for parents.
 8. Provide Meals and/or Meal Supplements according to USDA National School Lunch Program (NSLP) and National School Breakfast Program (NSBP) Guidelines for preschool age students enrolled in the Head Start/State Preschool Programs at the school sites mentioned above.
 9. Participate in collaborative decisions with CDR Head Start/State Preschool in the administration and implementation of the Head Start/State Preschool Program, when applicable.
 10. In conjunction with the registration of preschool students in the student information system, the Rio School District will:
 - Provide any necessary training in the student information software.
 - Enter basic student information in the district attendance data base.
 - Keep all information collected confidential.
 - Provide School Identification numbers and State Identification numbers for each student.
 - Share outcome information for statistical purposes to CDR upon request.
 - Ensure that all classrooms are set up with the necessary phone lines and computer access to utilize the student information software as required by Rio School District.

Child Development Resources of Ventura County, Inc. Head Start/State Preschool Program agrees to:

1. Work in partnership with RSD on the organization and management of the installation of the Rio Lindo playground.
2. Absorb the total cost associated with the installation of the playground added behind the Rio Lindo portable classrooms, by contracted vendors.

Memorandum of Understanding

Rio School District &

Child Development Resources of Ventura County, Inc. Head Start/State Preschool

3. Remain responsible for the maintenance and repairs of the installed playground equipment as well as the playground rubber surface material, ensuring that it is safe and in good working condition at all times.
4. Operate and administer a Head Start federally funded and/or State Funded Preschool Program, which will serve a minimum of 40 preschool age children in an extended day program (6 hours), at Rio Lindo.
5. Partial cover of facilities and custodial cost by paying the amount of two hundred eighty-four dollars (\$284.00) per month per classroom.
6. Provide bilingual/bicultural teaching staff to provide preschool services to the children attending the Head Start/State Preschool Program offered at Rio Lindo.
7. In good faith, CDR will recruit enrollment from residents living in the Rio Lindo School District boundaries.
8. Provide children enrolled in the Head Start/State Preschool Program at Rio Lindo with a safe and healthy learning environment, a variety of activities that will help them develop socially, emotionally, intellectually, and physically in a manner to their stage of development toward an overall goal of social competence and school readiness.
9. Work cooperatively with the staff at Rio Lindo to ensure and enhance the continuity of children and address transition needs of families and children as they move from the Head Start/State Preschool Program to public education.
10. Participate with partnership agencies to collect, disseminate and share any necessary data and/or information for the administration and evaluation of the Head Start/State Preschool Program.
11. Participate in the registration, attendance and data collection of preschool students into the Rio School District's student information system by doing the following:
 - Facilitate the parent's completion of the "Authorization to Share Information"
 - Facilitate the parent's completion of the "Preschool Participation Packet" with demographic information including: child's first, middle and last name, gender, ethnicity, home language, primary language, home address and birth place: city, state and country.
 - Authenticate child's given name with a birth certificate
 - Maintain daily attendance in the on-line student information system
 - Update weekly names of new enrollees and children who have dropped

Memorandum of Understanding

Rio School District & Child Development Resources of Ventura County, Inc. Head Start/State Preschool

- Provide enrollment and assessment data to the Rio Neighborhood's for Learning in a timely manner
- 12. Retain exclusive rights and responsibilities over CDR employees.

Either party, upon thirty (30) days written notice, and per the terms and conditions of the Subcontract Agreement between the Rio Elementary School District and Child Development Resources of Ventura County, Inc. Head Start/State Preschool Program, may cancel this Memorandum of Understanding.

Signed and executed this day of 12.17., 2018



John D. Puglisi, Ph.D.,
Superintendent
Rio School District
2500 Vineyard Ave.
Oxnard, CA 93036



Jack Hinojosa, Chief Executive Officer
Child Development Resources of
Ventura County, Inc.
Head Start/State Preschool Program
221 Ventura Boulevard
Oxnard, CA 93036-0277

CHILD DEVELOPMENT RESOURCES AND RIO SCHOOL DISTRICT RIO LINDO ELEMENTARY SCHOOL LEASE AGREEMENT AMENDMENT

This Lease Agreement Amendment is hereby made and entered into by and between Rio School District hereinafter called DISTRICT and Child Development Resources of Ventura County, Inc. hereinafter called CDR on July 1, 2020.

DISTRICT hereby rents to CDR, subject to the terms and conditions of its original Agreement, for the premises at the Rio Lindo Elementary School in Oxnard, CA to occupy as Head Start/State Preschool classrooms and for no other purpose. The Lease Term remains the same (effective July 1, 2015 and ends June 30, 2024), and can be extended for an additional five-year period, if parties mutually agree and classroom space is available for use by CDR.

BACKGROUND:

On March 12, 2020, the Ventura County Public Health (VCPH) declared a local health emergency, and as a result of this declaration, the Head Start Centers, including the toddler center was closed on Monday, March 16, 2020, and remained closed through the end of our 2019-2020 program year. The closure was in support of the recommendations from public health officials to encourage "social distancing" to slow the spread of the virus.

At CDR, the health and safety of our staff and students is our highest priority. We will continue to work closely with the Ventura County Public Health (VCPH) to stay informed of important information and precautions relating to the coronavirus (COVID-19).

AMENDED TERMS OF THE AGREEMENT:

For the 2020-2021 program year, in preparation for the reopening of the centers, both parties agree on the following accommodations.

1. FACILITIES AND CUSTODIAL COST DURING COVID-19

CDR will contract and/or provide its own custodial services. DISTRICT will not bill CDR for expenses to help cover facilities and custodial costs incurred by the District.

2. FACILITIES ACCOMMODATIONS TO OPERATIONS DUE TO COVID-19.

For the 2020-2021 program year, CDR will work closely with the School District to help support the slowing of the spread of disease by following the CDC and the VCPH health guidelines. This will help inform our decisions and prepare for the reopening of our centers and help ensure staff and students have safe and healthy learning environments.

As part of its planning and preparation for the reopening of the centers, CDR has developed a "Universal Precautions Procedure for COVID-19 and Site-Specific Plan." This document is a site-specific prevention plan that will be implemented and enforced by CDR staff, in collaboration with the Rio School District, to support the health and safety of school district staff, CDR staff, and children in our program. For a copy of the plan, refer to Appendix A: Universal Precautions Procedure for COVID-19 and Site-Specific Plan.

CDR acknowledges the constant changes and updates relating to COVID-19 and will comply with any notices from VCPH for the need to close the center, if necessary.

CHILD DEVELOPMENT RESOURCES AND RIO SCHOOL DISTRICT RIO PLAZA AND RIO ROSALES LEASE AGREEMENT AMENDMENT

This Lease Agreement Amendment is hereby made and entered into by and between Rio School District hereinafter called DISTRICT and Child Development Resources of Ventura County, Inc. hereinafter called CDR on July 1, 2020.

DISTRICT hereby rents to CDR, subject to the terms and conditions of its original Agreement, for the premises at the Rio Plaza Elementary School and Rio Rosales Elementary School in Oxnard, CA.

BACKGROUND:

On March 12, 2020, the Ventura County Public Health (VCPH) declared a local health emergency, and as a result of this declaration, the Head Start Centers, including the toddler center was closed on Monday, March 16, 2020, and remained closed through the end of our 2019-2020 program year. The closure was in support of the recommendations from public health officials to encourage “social distancing” to slow the spread of the virus.

At CDR, the health and safety of our staff and students is our highest priority. We will continue to work closely with the Ventura County Public Health (VCPH) to stay informed of important information and precautions relating to the coronavirus (COVID-19).

AMENDED TERMS OF THE AGREEMENT:

For the 2020-2021 program year, in preparation for the reopening of the centers, both parties agree on the following accommodations.

1. FACILITIES AND CUSTODIAL COST DURING COVID-19

CDR will contract and/or provide its own custodial services. DISTRICT will not bill CDR for expenses to help cover custodial costs incurred by the DISTRICT.

2. FACILITIES ACCOMMODATIONS TO OPERATIONS DUE TO COVID-19.

For the 2020-2021 program year, CDR will work closely with the DISTRICT to help support the slowing of the spread of disease by staying updated and following the Center for Disease Control (CDC) and the VCPH health guidelines. This will help inform our decisions and prepare for the reopening of our centers and help ensure staff and students have continuous safe and healthy learning environments.

As part of its planning and preparation for the reopening of the centers, CDR has developed a “Universal Precautions Procedure for COVID-19, site-specific plans.” This document is a site-specific prevention plan that will be implemented and enforced by CDR staff, in collaboration with the DISTRICT, to support the health and safety of school district staff and children, CDR staff and children in our Head Start programs. For a copy of the plan, refer to: Universal Precautions Procedure for COVID-19.

CDR acknowledges the constant changes and updates relating to COVID-19 and will comply with any notices from the DISTRICT for the need to close the center, if necessary.

LEASE AGREEMENT

THIS LEASE AGREEMENT executed on the 1st day of July 2020 by and between Rio School District hereinafter called DISTRICT and Child Development Resources of Ventura County, Inc. hereinafter called CDR.

OFFER TO RENT

DISTRICT hereby rents to CDR, subject to the following terms and conditions of this Agreement, the premises at the Rio Plaza Elementary School and Rio Rosales Elementary School in Oxnard, CA to occupy as Head Start/State Preschool classrooms and for no other purpose.

TERM

The term of this agreement shall be for twelve (12) months beginning July 1, 2020, and ending on June 30, 2021, and can be extended for two (2) additional periods running July through June, if parties mutually agree and classroom space is available.

USE

CDR shall use the leased space for the purpose of a Head Start/State Preschool Program and uses incidental thereto. Such use shall be conducted in a manner that does not disrupt the DISTRICT's existing activities on the premises.

TERMINATION OF LEASE

The lease runs for the full term as specified above. The only exception is in the event classroom space is no longer available. Either party shall notify the other in writing at least 30 days prior to vacating the premises, or in the case of the DISTRICT if the classroom is no longer available.

RENT

CDR shall pay to the DISTRICT the total for rent for the lease term of One dollar (\$1.00) per year payable annually on or before August 1, 2020. The difference between the actual value of the property and the \$1.00 rent will be used as an In-Kind donation. The Rio School District will provide CDR with a value statement indicating the actual value of the classroom being utilized.

FACILITIES AND CUSTODIAL COST.

CDR will contract and/or provide its own custodial services. DISTRICT will not bill CDR for expenses to help cover facilities and custodial costs incurred by the District.

POSSESSION

CDR has examined and knows the condition of the property and by taking possession acknowledges that they have received the same in good order and condition except as herein otherwise stated.

RIGHT OF ENTRY

DISTRICT shall have the right to enter the classroom at any time in order to inspect the premises, make necessary repairs, alterations or improvements, to supply services as agreed or for any reasonable purpose.

MAINTENANCE, REPAIRS OR ALTERATIONS

CDR may not make any alterations to the leased premises without the consent in writing of the DISTRICT. DISTRICT will provide custodial services five (5) days per week (Monday through Friday, excluding Rio School Board approved holidays and non-school days) and maintenance services when needed while the Head Start/State Preschool is operational at the school sites mentioned above.

When scheduling work to be completed on Lessor’s campuses, especially during District vacation or non-school days, The Lessor must notify CDR of any possible interruption of calendar days for CDR’s programs. CDR is required to provide services for an established number of days per year. Proper notice must be given to parents to find alternative care for their children.

OPERATION ON NON-SCHOOL DAYS

As indicated in the facilities and custodial cost, CDR will contract and/or provide its own custodial services. Therefore, it will not incur the cost for facilities support that is requested on non-Rio School District classified contract days, weekends and Rio School District Board approved holidays and non-school days.

INDEMNIFICATION

Provider agrees to defend, indemnify, and hold harmless District, its officers, agents, employees, and/or volunteers from any and all claims, demands, losses, damages and expenses, including legal fees and costs, or other obligations or claims arising out of any liability or damage to person or property, or any other loss, sustained or claimed to have been sustained arising out of activities of the Provider or those of any of its officers, agents, employees, or subcontractors of Provider, whether such act or omission is authorized by this Agreement or not. Provider shall also pay for all damage to the Real and Personal Property of the District, or loss or theft of such Property, done or caused by such persons. District assumes no responsibility whatsoever for any property placed on District premises by Provider, Provider’s agents, employees or subcontractors. Provider further hereby waives all rights of subrogation that it may have against the District. The provisions of this Agreement do not apply to any damage or losses caused solely by the negligence of the District or any of its officers, agents, employees, and/or volunteers.

COVENANTS

The covenants and conditions herein contained shall apply to and bind the legal representatives and assigns of the parties hereto, and all covenants are to be construed as conditions of the Agreement.

OCCUPANTS

CDR agrees to provide qualified bilingual (Spanish/English) instructional staff to serve a minimum of 60 children in an extended day program (6 Hours). The facilities will be used Monday through Fridays, except Holidays.

Commented [SG1]: As a result of COVID 19 CDR will start by serving only 10 children per classroom

NOTICES

Any notice which either party may require to give may be given by mailing the same, by registered mail to the addresses set forth following the signatures.

SPECIAL PROVISIONS

See the attached Memorandum of Understanding between CDR and the DISTRICT dated July 1, 2020, which defines the terms and conditions of this agreement.

ENTIRE AGREEMENT

The terms and conditions of the Agreement, together with the MOU are the entire agreement and understanding of the parties. BOTH PARTIES acknowledge that they have read this Agreement and understand its provisions and agree to occupy said premises under the terms of the Agreement. In witness, the parties have executed this agreement on the day and year written below:

Lessor:

John D. Puglisi, Ph.D., Superintendent
Rio School District
2500 Vineyard Ave.
Oxnard, CA 93036

Date

Lessee:

Jack Hinojosa, Chief Executive Officer
Child Development Resources of Ventura County, Inc.
Head Start/State Preschool Program
221 Ventura Boulevard
Oxnard, CA 93036-0277

Date

**Memorandum of Understanding between
Rio School District and
Child Development Resources of Ventura County, Inc. Head Start/State Preschool**

This Memorandum of Understanding (MOU) explains and confirms the agreement between Rio School District and Child Development Resources of Ventura County, Inc. Head Start/State Preschool program. These agencies agree to collaborate in the development and implementation of Head Start/State Preschool classes in the Rio School District.

Memorandum of Understanding Purpose:

This Memorandum of Understanding is to confirm an effective and collaborative working relationship between the parties named above. The purpose of this collaborative partnership will be to provide preschool educational services to eligible children who reside within the boundaries of the Rio School District. The Rio School District and Child Development Resources of Ventura County, Inc. Head Start/State Preschool Program will work cooperatively to administer preschool age programs to serve children whose parents reside within the boundaries of these elementary schools.

Memorandum of Understanding Timeline:

This Memorandum of Understanding will be in effect from July 1, 2020 through June 30, 2021, and can be extended for two (2) additional periods running July thru June, if parties mutually agree and classroom space is available for use by Child Development Resources of Ventura County, Inc. Head Start/State Preschool Program.

Memorandum of Understanding Agreement and Description of Services:

The Rio School District agrees to:

1. Provide classroom space at Rio Plaza Elementary School (1) and Rio Rosales Elementary School (2) to house a Head Start federally funded program and/or a State Preschool Funded Program, which will serve a minimum of 60 preschool age children in an extended day program (6 hours).
2. Notify CDR when a facility is locked down for security purposes or if utilities need to be turned off, as a result of an emergency, so that our staff can contact families of our students in a timely manner.
3. Provide space for evening monthly parent involvement activities such as parent meetings and educational workshops for parents.

**Memorandum of Understanding between
Rio School District and
Child Development Resources of Ventura County, Inc. Head Start/State Preschool**

4. Provide Meals and/or Meal Supplements according to USDA National School Lunch Program (NSLP) and National School Breakfast Program (NSBP) Guidelines for preschool age students enrolled in the Head Start/State Preschool Programs at the school sites mentioned above.
5. Participate in collaborative decisions with Child Development Resources of Ventura County, Inc. Head Start/State Preschool in the administration and implementation of the Head Start/State Preschool Program, when applicable.
6. In conjunction with the registration of preschool students in the student information system, the Rio School District will:
 - Provide any necessary training in the student information software
 - Enter basic student information in the district attendance data base
 - Keep all information collected confidential.
 - Provide School Identification numbers and State Identification numbers for each student.
 - Share outcome information for statistical purposes to CDR upon request.
 - Ensure that all classrooms are set up with the necessary phone lines and computer access to utilize the student information software as required by Rio School District.

Child Development Resources of Ventura County, Inc. Head Start/State Preschool Program agree to:

1. Operate and administer a Head Start federally funded and/or State Funded Preschool Program, which will serve a minimum of 100 preschool age children in an extended day program (6 hours), at Rio Plaza Elementary School and Rio Rosales Elementary School.
2. CDR will contract and/or provide its own custodial services. DISTRICT will not bill CDR for expenses to help cover facilities and custodial costs incurred by the District.
3. Provide bilingual/bicultural teaching staff to provide preschool services to the children attending the Head Start/State Preschool Program offered at the above-mentioned schools.
4. In good faith CDR will recruit enrollment from residents living in the Rio School District boundaries followed by residents living outside the district.
5. Provide children enrolled in the Head Start/State Preschool Program at the above-mentioned schools with a learning environment and varied activities that will help them develop socially, emotionally, intellectually, and physically

**Memorandum of Understanding between
Rio School District and
Child Development Resources of Ventura County, Inc. Head Start/State Preschool**

- in a manner to their stage of development toward an overall goal of social competence and school readiness.
6. Work cooperatively with the staff at Rio School District and at each school site to ensure and enhance the continuity of children and address transition needs of families and children as they move from the Head Start/State Preschool Program to public education.
 7. Participate with partnership agencies to collect, disseminate and share any necessary data and/or information for the administration and evaluation of the Head Start/State Preschool Program.
 8. Participate in the registration, attendance and data collection of preschool students into the Rio School District's student information system by doing the following:
 - Facilitate the parent's completion of the "Authorization to Share Information."
 - Facilitate the parent's completion of the "Preschool Participation Packet" with demographic information including child's first, middle and last name, gender, ethnicity, home language, primary language, home address and birthplace: city, state, and country.
 - Authenticate child's given name with a birth certificate.
 - Maintain daily attendance in the on-line student information system.
 - Update weekly names of new enrollees and children who have dropped.
 - Provide one-page copies of the pre and post DRDP on all enrolled students. Results of additional assessment tools may be requested in the future.
 - Provide this enrollment and assessment data to the Rio Neighborhood for Learning in a timely manner.
 9. Coordinate the setting up of the classroom spaces at the above-mentioned schools.
 10. Retains exclusive rights and responsibilities over CDR employees.

**Memorandum of Understanding between
Rio School District and
Child Development Resources of Ventura County, Inc. Head Start/State Preschool**

Either party, upon thirty (30) days written notice, and per the terms and conditions of the Subcontract Agreement between the Rio Elementary School District and Child Development Resources of Ventura County, Inc. Head Start/State Preschool Program, may cancel this Memorandum of Understanding.

Signed and executed this day of _____, 2020

John D. Puglisi, Ph.D.,
Superintendent
Rio School District
2500 Vineyard Ave.
Oxnard, CA 93036

Jack Hinojosa, Chief Executive Officer
**Child Development Resources of
Ventura County, Inc.**
Head Start/State Preschool Program
221 Ventura Boulevard
Oxnard, CA 93036-0277

9.12



Agenda Item Details

Meeting	Oct 21, 2020 - RSD Regular Board Meeting
Category	9. Consent
Subject	9.12 Approval of CREDIT Change Order 16.1 from KYA Services at Rio Del Sol
Access	Public
Type	Action (Consent)
Fiscal Impact	Yes
Budgeted	Yes
Budget Source	Measure L Funds
Recommended Action	It is recommended that the Board approve the CREDIT Change Order from KYA Services for the deleted scope of work at Rio Del Sol.

Public Content

Speaker:

Wael Saleh, Assistant Superintendent, Business Services

Rationale:

All contractors are required to provide 3 weeks worth of watering the site for dust control purposes. This credit is for the dust control water that was not used or needed at the site, district construction management team mitigated dust control in an effort to offer cost savings to the District.

RIO STEAM Bldg C - KYA CO16.1 - Recommendation Letter to Board - 10-1-20 (1).pdf (220 KB)

Administrative Content

Executive Content

Our adopted rules of Parliamentary Procedure, Robert's Rules, provide for a consent agenda listing several items for approval of the Board by a single motion. Most of the items listed under the consent agenda have gone through Board subcommittee review and recommendation. Documentation concerning these items has been provided to all Board members and the public in advance to assure an extensive and thorough review. Items may be removed from the consent agenda at the request of any board member.

Balfour Beatty Construction

Rio School District
1800 Solar Dr., 3rd Floor
Oxnard, CA 93030

October 1, 2020

Attn; Dr. Puglisi

Subject: Rio Del Sol, STEAM Academy, Building C
Rio School District
Oxnard, CA

Re: Project 19-0068-015 Rio Del Sol, STEAM Academy, Building C
BP #16 Flooring
Recommendation to Approve CO #16.1 to KYA Services LLC

Dear Dr. Puglisi,

Please accept this letter as recommendation to request approval for CO #16.1 to KYA Services LLC for the deleted scope items at the above Project, and as amendment to their contract. Scope change to the project is as follows;

PCO No.	GC No.	Description	Reason	Cost/Credit
16.1	1	Credit for Water Truck	All contractors were required to provide 3 weeks' worth of watering the site for dust control purposes (compliance with environmental requirements). In an effort to save the District money, when possible, Balfour Beatty took care of the dust control. This credit is for the dust control owed by the contractor that was not used.	\$ (2,000.00)
Total CO #16.1				\$ (2,000.00)
Previous Approved CO's				\$ -
Original Contract				\$ 235,000.00
Revised Contract				\$ 233,000.00

Should you have any questions, please contact me at any time.

Respectfully,



Jesus Muguerza Ibarra
Assistant Project Manager, Balfour Beatty

cc. Wael Saleh, Rio School District
Dennis Kuykendall, Balfour Beatty

**Rio School District
1800 Solar Dr., 3rd Floor
Oxnard, Ca 93030**

**CO 16.1
8-4-20**

PROJECT NO: 19-0068-015

CO NO: 16.1

PROJECT NAME: RIO Del Sol, STEAM Academy, Building C

CONTRACTOR: KYA Services LLC

SCOPE OF WORK: SEE ATTACHED

COST:

Original Contract Amount	\$ 235,000.00
Previously Approved Change Orders	\$ 0.00
This Change Order	\$ (2,000.00)
Adjusted Contract Amount	\$ 233,000.00

TIME:

Original Contract Completion Date	June 2020
Previously Approved Completion Extension Days	0
Completion Days Extension this Change Order	0
Adjusted Contract Completion Date	June 2020

IT IS AGREED BY THE CONTRACTOR THAT THE AMMENDED CONTRACT AMOUNT AND/OR TIME, IF ANY, INCLUDES FULL AND COMPLETE EQUITABLE ADJUSTMENT AND COMPENSATION FOR ALL CONTRACT WORK AND EXTRA WORK PERFORMED ON THE PROJECT INCLUDING BUT NOT LIMITED TO CHANGES, DIFFERING SITE CONDITIONS, SUSPENSIONS, DELAYS, RESCHEDULING, ACCELERATION, IMPACT AND EXTENDED OVERHEAD AS IT RELATES SPECIFICALLY TO ITEMS OF THE ATTACHED LISTING. CONTRACTOR HEREBY WAIVES ANY AND ALL RIGHT TO ADDITIONAL COMPENSATION OR TIME ARISING OUT OF THE WORK SPECIFIC TO ITEMS OF THE ATTACHED LISTING, AND HEREBY ACKNOWLEDGES AND AGREES THAT THE AMOUNT SHOWN ABOVE CONSTITUTES PAYMENT IN FULL ACCORDING TO THE CONTRACT DOCUMENTS.

EXCEPT TO THE EXTENT THE CONTRACT HAS BEEN MODIFIED BY PREVIOUSLY ISSUED DISTRICT CHANGE ORDERS, AND FURTHER MODIFIED BY THIS CHANGE ORDER, THE CONTRACT REMAINS IN FULL FORCE AND EFFECT.

RIO SCHOOL DISTRICT

Contractor: KYA Services LLC

By _____

By _____

Date _____

Date _____

District Architect; Architecture 4 Education

District PM/CM; Balfour Beatty Construction

By _____

By _____

Date _____

Date _____

Rio School District

Project No 19-0068-015

Rio Del Sol, STEAM Academy, Building C
BP #16 Flooring
KYA Services LLC

CO #16.1

10/1/2020

Original Contract

\$ 235,000.00

PCO No.	GC No.	Description	Reason	Cost/Credit
16.1	1	Credit for Water Truck	All contractors were required to provide 3 weeks' worth of watering the site for dust control purposes (compliance with environmental requirements). In an effort to save the District money, when possible, Balfour Beatty took care of the dust control. This credit is for the dust control owed by the contractor that was not used.	\$ (2,000.00)

Total CO #16.1	\$ (2,000.00)
Previous Approved CO's	\$ -
Original Contract	\$ 235,000.00
Revised Contract	\$ 233,000.00

9.13



Agenda Item Details

Meeting	Oct 21, 2020 - RSD Regular Board Meeting
Category	9. Consent
Subject	9.13 Approval of Change Order 5.3 from K&Z Cabinets, Inc. at Rio Del Sol
Access	Public
Type	Action (Consent)
Fiscal Impact	Yes
Dollar Amount	520.38
Budgeted	Yes
Budget Source	Measure L Funds
Recommended Action	It is recommended that the Board approve Change Order 5.3 from K&Z Cabinet Co., Inc. at Rio Del Sol.

Public Content

Speaker:
Wael Saleh, Assistant Superintendent, Business Services

Rationale:

At Rio Del Sol, Bldg. C, maker space, one of the counter tops has an exposed steel bracket and in order to conceal it, an additional Baltic Birch panel has to be added to the contractor's scope of work. The exposed steel bracket was due to a change in the design for the betterment of the construction.

RIO STEAM Bldg C - K&Z CO5.3 - Recommendation Letter to Board - 10-1-20.pdf (626 KB)

Administrative Content

Executive Content

Our adopted rules of Parliamentary Procedure, Robert's Rules, provide for a consent agenda listing several items for approval of the Board by a single motion. Most of the items listed under the consent agenda have gone through Board subcommittee review and recommendation. Documentation concerning these items has been provided to all Board

members and the public in advance to assure an extensive and thorough review. Items may be removed from the consent agenda at the request of any board member.

Balfour Beatty Construction

Rio School District
1800 Solar Drive, 3rd Floor
Oxnard, CA 93030

October 1, 2020

Attn; Dr. Puglisi

Subject: Rio Del Sol, STEAM Academy, Building C
Rio School District
Oxnard, CA

Re: Project 19-0068-015 Rio Del Sol, STEAM Academy, Building C
BP #5 Finish Carpentry and Architectural Woodwork
Recommendation to Approve CO #5.3 K&Z Cabinet Co., Inc.

Dear Dr. Puglisi,

Please accept this letter as recommendation to request Board approval for CO #5.3 from K&Z Cabinet Co., Inc. for the added scope items at the above Project, and as amendment to their contract. Scope change to the project is as follows;

PCO No.	GC No.	Description	Reason	Cost/Credit
5.5	5	Additional Baltic Birch Panel at Counter	Cost to provide and install and additional Baltic Birch back panel to conceal exposed steel brackets as noted in the punch list.	\$ 520.38
Total CO #5.3				\$ 520.38
Previous Approved CO's				\$ (4,520.68)
Original Contract				\$ 378,470.00
Revised Contract				\$ 374,469.70

Should you have any questions, please contact me at any time.

Respectfully,



Jesus Muguerza Ibarra
Assistant Project Manager, Balfour Beatty

cc. Wael Saleh (RSD)
Dennis Kuykendall, Balfour Beatty

**Rio School District
1800 Solar Drive, 3RD Floor
Oxnard, Ca 93030**

**CO 5.3
10-1-20**

PROJECT NO: 19-0068-015

CO NO: 5.3

PROJECT NAME: RIO Del Sol, STEAM Academy, Building C

CONTRACTOR: K&Z Cabinet Co., Inc.

SCOPE OF WORK: SEE ATTACHED

COST:

Original Contract Amount	\$ 378,470.00
Previously Approved Change Orders	\$ (4,520.68)
This Change Order	\$ 520.38
Adjusted Contract Amount	\$ 374,469.70

TIME:

Original Contract Completion Date	June 2020
Previously Approved Completion Extension Days	0
Completion Days Extension this Change Order	0
Adjusted Contract Completion Date	June 2020

IT IS AGREED BY THE CONTRACTOR THAT THE AMMENDED CONTRACT AMOUNT AND/OR TIME, IF ANY, INCLUDES FULL AND COMPLETE EQUITABLE ADJUSTMENT AND COMPENSATION FOR ALL CONTRACT WORK AND EXTRA WORK PERFORMED ON THE PROJECT INCLUDING BUT NOT LIMITED TO CHANGES, DIFFERING SITE CONDITIONS, SUSPENSIONS, DELAYS, RESCHEDULING, ACCELERATION, IMPACT AND EXTENDED OVERHEAD AS IT RELATES SPECIFICALLY TO ITEMS OF THE ATTACHED LISTING. CONTRACTOR HEREBY WAIVES ANY AND ALL RIGHT TO ADDITIONAL COMPENSATION OR TIME ARISING OUT OF THE WORK SPECIFIC TO ITEMS OF THE ATTACHED LISTING, AND HEREBY ACKNOWLEDGES AND AGREES THAT THE AMOUNT SHOWN ABOVE CONSTITUTES PAYMENT IN FULL ACCORDING TO THE CONTRACT DOCUMENTS.

EXCEPT TO THE EXTENT THE CONTRACT HAS BEEN MODIFIED BY PREVIOUSLY ISSUED DISTRICT CHANGE ORDERS, AND FURTHER MODIFIED BY THIS CHANGE ORDER, THE CONTRACT REMAINS IN FULL FORCE AND EFFECT.

RIO SCHOOL DISTRICT

Contractor: K&Z Cabinet Co., Inc.

By _____

By _____

Date _____

Date _____

District Architect; Architecture 4 Education

District PM/CM; Balfour Beatty Construction

By _____

By _____

Date _____

Date _____

Rio School District

Project No 19-0068-015

Rio Del Sol, STEAM Academy, Building C
BP #5 Finish Carpentry and Architectural Woodwork
K&Z Cabinet Co., Inc.

CO #5.3

10/1/2020

Original Contract

\$ 378,470.00

PCO No.	GC No.	Description	Reason	Cost/Credit
5.5	5	Additional Baltic Birch Panel at Counter	Cost to provide and install and additional Baltic Birch back panel to conceal exposed steel brackets as noted in the punch list.	\$ 520.38

Total CO #5.3	\$ 520.38
Previous Approved CO's	\$ (4,520.68)
Original Contract	\$ 378,470.00
Revised Contract	\$ 374,469.70



RACHEL ADAMS, AIA, LEED AP
OLIVIA GRAF DOYLE

September 29, 2020

Jesus Muguerza Ibarra
Assistant Project Manager
Balfour Beatty Construction
300 East Esplanade, Suite 1120
Oxnard, CA 93036

RE: PCO #5.5 Additional Baltic Birch Panel at Counter

Dear Jesus,

We received the PCO on 9.8.20 and reviewed it against our documents and correspondence. We have the following comments:

1. Detail 6/A10.48 shows counter brackets concealed behind Baltic Birch panel, which applies to both counter locations.
2. Due to recommendation by Structural Steel contractor to replace counter support steel angles with tube steel, brackets could not be installed as detailed.

Therefore, we feel the cost is reasonable and can recommend RSD Board approval of \$520.38. Please forward final CO for signature.

Sincerely,

Olivia Graf Doyle
Design Principal / Partner

Balfour Beatty

Architecture 4 Education
41 N Fair Oaks Ave
Pasadena, CA 91103

September 8, 2020

Attn; Olivia Graf-Doyle

Subject: Rio Del Sol, STEAM Academy, Building C
Rio School District
Oxnard, CA

Re: Project 19-0068-015 Rio Del Sol, STEAM Academy, Building C
Bid Package #5 Finish Carpentry and Architectural Woodwork
Request to Review PCO #5.5 from K&Z Cabinet Co., Inc.

Dear Ms. Graf-Doyle,

Please accept this letter as a request to review PCO #5.5 from K&Z Cabinet Co., Inc. for the added scope items for the above Project. Scope change to the project is as follows;

PCO 5.5 Additional Baltic Birch Panel at Counter

Reason; Cost to provide and install and additional Baltic Birch back panel to conceal exposed steel brackets as noted in the punch list.

Project Cost Update:

K&Z Cabinet Co., Inc. Base Agreement	\$378,470.00
PCO #5.5	\$ 520.38
Previous Approved COs	(\$ 4,520.68)
Total Construction Cost to Date (Base Agreement + Approved COs)	\$373,949.32

Should you have any questions, please contact me at any time.

Respectfully,



Jesus Muguerra Ibarra
Assistant Project Manager, Balfour Beatty

cc. Wael Saleh, Rio School District
Dennis Kuykendall, Balfour Beatty

K & Z Cabinet Co., Inc.

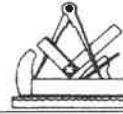

1450 South Grove Avenue, Ontario California 91761 • (909) 947-3567 • Fax (909) 947-3264 • State Lic. 319196

PROPOSED CHANGE ORDER

Date: 09/03/20

PCO #: 6

To: Balfour Beatty Construction
3001 North Ventura Rd.
Oxnard, CA 93036

Attention: Jesus Muguerza

K&Z Job #: 6003

Project: Rio Steam K-8 Campus - Bldg. C

Reference: Add'l Baltic Birch Back Panel to Hide Exposed Steel Brackets

We Are Proposing The Following Changes:

ITEM: 1	1/4" Baltic Birch Back Panels w/ a Clear Finish:	2 EA @	\$150.00 EA		\$300.00
ITEM: 2	Field Labor:	2 MH @	\$76.25 HR		\$152.50
Sub Total					\$452.50
O.H.				10%	\$45.25
Profit				5%	\$22.63
Credits					
Grand Total					\$520.38

The above price is guaranteed for 30 days from date of this quote.

We are NOT proceeding with this extra until we have received a written change order from your company.

We are proceeding with this change based on conversation 9/2/2020.

A written billable change order is required before release to production.

K&Z Cabinet Co., Inc.

Accepted By: _____

Joseph V. Guidera Jr.
Project Manager

Date: _____

9.14



Agenda Item Details

Meeting	Oct 21, 2020 - RSD Regular Board Meeting
Category	9. Consent
Subject	9.14 Approval of Change Order from Precision Plumbing Mechanical for Project 20-13L at Rio Plaza.
Access	Public
Type	Action (Consent)
Fiscal Impact	Yes
Dollar Amount	7,330.00
Budgeted	Yes
Budget Source	Measure L Funds
Recommended Action	It is recommended that the Board approve the Change Order from Precision Plumbing Mechanical at Rio Plaza.

Public Content

Speaker:

Wael Saleh, Assistant Superintendent, Business Services

Rationale:

This change order is for additional plumbing repairs at Rio Plaza. Plumbing issues were found and repaired during the COVID 19 touchless repairs throughout the Rio Plaza campus.

The extra repairs for Rio Plaza are as follows:

- Classroom #1 - Sink drains slowly
- Classroom #5 - One (1) angle stop needs to be replaced.
- Classroom #7 - One (1) angle stop needs to be replaced.
- Classroom #8 - One (1) angle stop needs to be replaced. needs to be replaced, sink doesn't drain.
- Classroom #12 - One (1) angle stop needs to be replaced.
- Classroom #13 - One (1) angle stop and p-trap need to be replaced.
- Classroom #16 - One (1) angle stop needs to be replaced.
- Classroom #27 - One (1) angle stop needs to be replaced, sink drains slow.
- Girls Restroom near Classroom #13 - Three (3) angle stops needs to be replaced.
- Boys Restroom near Classroom #17 - One (1) angle stop needs to be replaced.
- Adult Restroom in MPR - Two (2) angle stops needs to be replaced, urinal doesn't drain.
- Girls Restroom near Classroom #5 - One (1) angle stop needs to be replaced.
- Boy's Restroom near Classroom #5 - Two (2) angle stops need to be replaced.

20-13L COR#1 for Precision for October Board Approval FINAL 10 12 2020 (1).pdf (191 KB)

Administrative Content**Executive Content**

Our adopted rules of Parliamentary Procedure, Robert's Rules, provide for a consent agenda listing several items for approval of the Board by a single motion. Most of the items listed under the consent agenda have gone through Board subcommittee review and recommendation. Documentation concerning these items has been provided to all Board members and the public in advance to assure an extensive and thorough review. Items may be removed from the consent agenda at the request of any board member.

Balfour Beatty Construction

Rio School District
1800 Solar, 3rd Floor
Oxnard, CA 93030

October 12, 2020

Attn: Dr. Puglisi

Subject: Rio Lindo Elementary School
Rio School District
Oxnard, CA

Re: Project 20-13L COVID 19 Touchless Plumbing Fixture Replacements at Rio Plaza
Elementary School
Precision Plumbing-Mechanical
Recommendation to Approve CO #1 to Precision Plumbing-Mechanical

Dear Dr. Puglisi,

Please accept this letter as recommendation to request approval for CO #1 to Precision Plumbing-Mechanical for Added & Deleted scope of work items at the above Project, and as amendment to their contract. Scope change to the project is as follows;

PCO No.	GC No.	Description	Reason	Cost/Credit
1	Prec	Additional Plmg Repairs at Rio Plaza	Plmg Issues Found/Repaired During COVID 19 Touchless Repairs thru out Campus	\$ 7,330.00

Total CO #1	\$ 7,330.00
Previous Approved CO's	\$ -
Original Contract	\$ 56,335.00
Revised Contract	\$ 63,665.00

Should you have any questions, please contact me at any time.

Respectfully,



Keith Henderson
Senior Project Manager, Balfour Beatty

cc. Wael Saleh, Rio School District
Dennis Kuykendall, Balfour Beatty
Jesus Mugerza Ibarra

**Rio School District
1800 Solar, 3rd Floor
Oxnard, Ca 93030**

**CO 1
10-12-2020**

PROJECT NO: RSD 20-13L

CO NO: 1

PROJECT NAME: COVID 19 Touchless Plumbing Fixture Replacements at Rio Plaza Elementary School

CONTRACTOR: Precision Plumbing-Mechanical

SCOPE OF WORK: SEE ATTACHED

COST:

Original Contract Amount	\$ 56,335.00
Previous Approved Change Orders	\$ 0.00
This Change Order	\$ 7,330.00
Adjusted Contract Amount	\$ 63,665.00

TIME:

Original Contract Completion Date	October 2020
Previously Approved Completion Extension Days	0
Completion Days Extension this Change Order	0
Adjusted Contract Completion Date	October 2020

IT IS AGREED BY THE CONTRACTOR THAT THE AMMENDED CONTRACT AMOUNT AND/OR TIME, IF ANY, INCLUDES FULL AND COMPLETE EQUITABLE ADJUSTMENT AND COMPENSATION FOR ALL CONTRACT WORK AND EXTRA WORK PERFORMED ON THE PROJECT INCLUDING BUT NOT LIMITED TO CHANGES, DIFFERING SITE CONDITIONS, SUSPENSIONS, DELAYS, RESCHEDULING, ACCELERATION, IMPACT AND EXTENDED OVERHEAD AS IT RELATES SPECIFICALLY TO ITEMS OF THE ATTACHED LISTING. CONTRACTOR HEREBY WAIVES ANY AND ALL RIGHT TO ADDITIONAL COMPENSATION OR TIME ARISING OUT OF THE WORK SPECIFIC TO ITEMS OF THE ATTACHED LISTING, AND HEREBY ACKNOWLEDGES AND AGREES THAT THE AMOUNT SHOWN ABOVE CONSTITUTES PAYMENT IN FULL ACCORDING TO THE CONTRACT DOCUMENTS.

EXCEPT TO THE EXTENT THE CONTRACT HAS BEEN MODIFIED BY PREVIOUSLY ISSUED DISTRICT CHANGE ORDERS, AND FURTHER MODIFIED BY THIS CHANGE ORDER, THE CONTRACT REMAINS IN FULL FORCE AND EFFECT.

RIO SCHOOL DISTRICT

Contractor: Precision Plumbing-Mechanical

By _____

By _____

Date _____

Date _____

District Architect: N/A

District PM/CM: Balfour Beatty Construction

By _____

By _____

Date _____

Date 10/12/2020

PCO to Contract
Rio Bid RSD #20-13L

Rio School District
Project No RSD 20-13L

CO #1
10/12/2020

COVID 19 Touchless Plmg Fixture R & R
at Rio Plaza Elementary School

Original Contract \$ 56,335.00

PCO No.	GC No.	Description	Reason	Cost/Credit
1	Prec	Additional Plmg Repairs at Rio Plaza	Plmg Issues Found/Repaired During COVID 19 Touchless Repairs thru out Campus	\$ 7,330.00

Total CO #1 \$ 7,330.00
Previous Approved CO's \$ -
Original Contract \$ 56,335.00
Revised Contract \$ 63,665.00

#13505

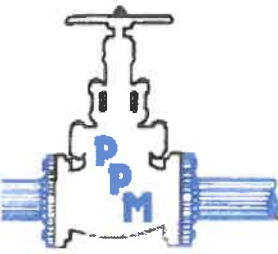

PRECISION Plumbing-Mechanical

5350 Gabbert Road • Moorpark, CA 93021 • (805) 529-4748 • fax (805) 529-5433

Proposal

Page No. of Pages

PROPOSAL SUBMITTED TO Balfour Beatty – Keith Henderson		PHONE	DATE 10-08-20
STREET		JOB NAME COR #1 Additional Labor and Materials	
CITY, STATE AND ZIP CODE		JOB LOCATION	
ARCHITECT	DATE OF PLANS	khenderson@balfourbeattyus.com	JOB PHONE

We hereby propose to furnish in accordance with specifications below, or on attached pages, all labor and materials necessary to complete the following:

We propose to provide the labor and material needed to install the additional materials and fixtures at the above referenced project due to not being included in the original scope and/or being found defective at the time of construction.

SEE ATTACHED COST BREAKDOWN FOR ITEMS INCLUDED IN THIS PROPOSAL

WE PROPOSE hereby to furnish material and labor – complete in accordance with above specifications, for the sum of:
Seven Thousand Three Hundred Thirty Dollars & NO/100 dollars (\$ **7,330.00**)

Payment to be made as follows:
Monthly progress payments; Net 15 days invoice.

All material is guaranteed to be as specified. All work to be completed in a substantial workmanlike manner according to specifications submitted, per standard practices. Any alteration or deviation from above specifications involving extra costs will be executed only upon written orders, and will become an extra charge over and above the estimate. All agreements contingent upon strikes, accidents or delays beyond our control. Owner to carry fire, tornado and other necessary insurance. Our workers are fully covered by Workmen's Compensation Insurance.

Authorized Signature  **Daniel Bascom**

Note This proposal may be withdrawn by us if not accepted within **15** days.

ACCEPTANCE OF PROPOSAL The above prices, specifications and conditions are satisfactory and are hereby accepted. You are authorized to do the work as specified. Payment will be made as outline above.

Date of Acceptance. _____

Signature _____
 Signature _____

SUBCONTRACTOR NAME	SERVICE	TOTAL

OH/PROFIT 10% \$0.00
SUBCOTRACTOR TOTAL: \$0.00

EQUIPMENT

HOURS	DESCRIPTION	RATE	TOTAL
			\$0.00
			\$0.00
			\$0.00

EQUIPMENT TOTAL: \$0.00

LABOR

HOURS	CLASSIFICATION	RATE	TOTAL
24	Foreman	\$119.00	\$2,856.00
	Journeyman	\$108.00	\$0.00
16	Apprentice	\$79.00	\$1,264.00
	Foreman overtime	\$163.00	\$0.00
	Journeyman overtime	\$146.00	\$0.00
	Apprentice overtime	\$106.00	\$0.00

LABOR TOTAL \$4,120.00

JOB TOTAL \$7,329.21

Henderson, Keith

From: Daniel Bascom <daniel@ppmemail.com>
Sent: Thursday, October 1, 2020 8:15 AM
To: Henderson, Keith
Subject: List of Issues at Rio Plaza

External Email

Keith,

Below is a list of issues we found at Rio Plaza while testing all the angle stops and drains. I will order the material and schedule a shutdown to change the stops. Do you want me to include this in a COR with the additional faucets and flush valves or would you like to separate into two COR's?

- Classroom #1 – Sink drains slowly.
- Classroom #5 – One (1) angle stop needs to be replaced.
- Classroom #7 – One (1) angle stop needs to be replaced.
- Classroom #8 – One (1) angle stop needs to be replaced.
- Classroom #9 – One (1) angle stop needs to be replaced, sink doesn't drain.
- Classroom #12 – One (1) angle stop needs to be replaced.
- Classroom #13 – One (1) angle stop and p-trap need to be replaced.
- Classroom #16 – One (1) angle stop needs to be replaced.
- Classroom #27 – One (1) angle stop needs to be replaced, sink drains slow.
- Girls Restroom near Classroom #13 – Three (3) angle stops need to be replaced.
- Boys Restroom near Classroom #17 – One (1) angle stop needs to be replaced.
- Adult Restroom in MPR – Two (2) angle stops need to be replaced.
- Men's Restroom in Administration two (2) angle stops need to be replaced, urinal doesn't drain.
- Girls Restroom near Classroom #5 – One (1) angle stop needs to be replaced.
- Boy's Restroom near Classroom #5 – Two (2) angle stops need to be replaced.

Thank you,

Daniel Bascom

Precision Plumbing-Mechanical

daniel@ppmemail.com

Office: (805) 529-4748

Fax: (805) 529-5433

Mobile: (805) 218-0960

www.precisionplumbingmechanical.com

9.15



Agenda Item Details

Meeting	Oct 21, 2020 - RSD Regular Board Meeting
Category	9. Consent
Subject	9.15 Approval of Change Order from Kiwitt's General Building for added scope of work at Rio Rosales
Access	Public
Type	Action (Consent)
Fiscal Impact	Yes
Dollar Amount	5,850.00
Budgeted	Yes
Budget Source	Measure L
Recommended Action	It is recommended that the Board approve the Change Order from Kiwitt's General Building at Rio Rosales.

Public Content

Speaker:

Wael Saleh, Assistant Superintendent, Business Services

Rationale:

This change order is to install new LED lighting in the Bathrooms undergoing COVID 19 repairs due to non-functioning and non energy saving at Rio Rosales. The existing florescent lighting in 8 bathrooms was found to not be functioning correctly and lighting was too dim. Replacement of LED Lighting will correct the problem and save energy.

20-25L COR#1 Kiwitt for October Board Approval 10 13 2020 (1).pdf (470 KB)

Administrative Content

Executive Content

Our adopted rules of Parliamentary Procedure, Robert's Rules, provide for a consent agenda listing several items for approval of the Board by a single motion. Most of the items listed under the consent agenda have gone through Board subcommittee review and recommendation. Documentation concerning these items has been provided to all Board members and the public in advance to assure an extensive and thorough review. Items may be removed from the consent agenda at the request of any board member.

Balfour Beatty Construction

Rio School District
1800 Solar, 3rd Floor
Oxnard, CA 93030

October 13, 2020

Attn; Dr. Puglisi

Subject: Rio Lindo Elementary School
Rio School District
Oxnard, CA

Re: Project 20-25L COVID 19 Bathroom Repairs at Rio Rosales Elementary School
Kiwitt's General Building
Recommendation to Approve CO #1 to Kiwitt's General Building

Dear Dr. Puglisi,

Please accept this letter as recommendation to request approval for CO #1 to Kiwitt's General Building for Added & Deleted scope of work items at the above Project, and as amendment to their contract. Scope change to the project is as follows;

PCO No.	GC No.	Description	Reason	Cost/Credit
1	KIWITT	Install New LED Lighting in Bathrooms undergoing COVID 19 Repairs due to non-functioning and Non Energy Saving	Existing Flourescent Lighting in 8 bathrooms was found to not be functioning correctly and lighting was too dim. Replacement LED Lighting will correct problem and save energy.	\$ 5,850.00

Total CO #1	\$ 5,850.00
Previous Approved CO's	\$ -
Original Contract	\$ 89,000.00
Revised Contract	\$ 94,850.00

Should you have any questions, please contact me at any time.

Respectfully,



Keith Henderson
Senior Project Manager, Balfour Beatty

cc. Wael Saleh, Rio School District
Dennis Kuykendall, Balfour Beatty
Jesus Mugerza Ibarra

**Rio School District
1800 Solar, 3rd Floor
Oxnard, Ca 93030**

**CO 1
10-13-2020**

PROJECT NO: RSD 20-25L

CO NO: 1

PROJECT NAME: COVID 19 Bathroom Repairs at Rio Rosales Elementary School

CONTRACTOR: Kiwitt's General Building

SCOPE OF WORK: SEE ATTACHED

COST:

Original Contract Amount	\$ 89,000.00
Previous Approved Change Orders	\$ 0.00
This Change Order	\$ 5,850.00
Adjusted Contract Amount	\$ 94,850.00

TIME:

Original Contract Completion Date	September 2020
Previously Approved Completion Extension Days	0
Completion Days Extension this Change Order	0
Adjusted Contract Completion Date	October 2020

IT IS AGREED BY THE CONTRACTOR THAT THE AMMENDED CONTRACT AMOUNT AND/OR TIME, IF ANY, INCLUDES FULL AND COMPLETE EQUITABLE ADJUSTMENT AND COMPENSATION FOR ALL CONTRACT WORK AND EXTRA WORK PERFORMED ON THE PROJECT INCLUDING BUT NOT LIMITED TO CHANGES, DIFFERING SITE CONDITIONS, SUSPENSIONS, DELAYS, RESCHEDULING, ACCELERATION, IMPACT AND EXTENDED OVERHEAD AS IT RELATES SPECIFICALLY TO ITEMS OF THE ATTACHED LISTING. CONTRACTOR HEREBY WAIVES ANY AND ALL RIGHT TO ADDITIONAL COMPENSATION OR TIME ARISING OUT OF THE WORK SPECIFIC TO ITEMS OF THE ATTACHED LISTING, AND HEREBY ACKNOWLEDGES AND AGREES THAT THE AMOUNT SHOWN ABOVE CONSTITUTES PAYMENT IN FULL ACCORDING TO THE CONTRACT DOCUMENTS.

EXCEPT TO THE EXTENT THE CONTRACT HAS BEEN MODIFIED BY PREVIOUSLY ISSUED DISTRICT CHANGE ORDERS, AND FURTHER MODIFIED BY THIS CHANGE ORDER, THE CONTRACT REMAINS IN FULL FORCE AND EFFECT.

RIO SCHOOL DISTRICT

Contractor: Kiwitt's General Building

By _____

By _____

Date _____

Date _____

District Architect; N/A

District PM/CM; Balfour Beatty Construction

By _____

By  _____

Date _____

Date 10/13/2020 _____

PCO to Contract
Rio Bid RSD #20-05L

Rio School District
 Project No RSD 20-25L

CO #1
 10/13/2020

COVID 19 Bathroom Repairs at Rio Rosales

Original Contract \$ 89,000.00

PCO No.	GC No.	Description	Reason	Cost/Credit
1	KIWITT	Install New LED Lighting in Bathrooms undergoing COVID 19 Repairs due to non-functioning and Non Energy Saving	Existing Flourescent Lighting in 8 bathrooms was found to not be functioning correctly and lighting was too dim. Replacement LED Lighting will correct problem and save energy.	\$ 5,850.00

Total CO #1	\$ 5,850.00
Previous Approved CO's	\$ -
Original Contract	\$ 89,000.00
Revised Contract	\$ 94,850.00

Henderson, Keith

From: Dustin Sartwell <dustinkgb@yahoo.com>
Sent: Monday, October 12, 2020 6:28 PM
To: Henderson, Keith; 'Charles Fichtner'
Subject: RIO ROSALES BATHROOM REMODELS
Attachments: 2BLTR-2X4_.pdf.pdf

External Email

Keith,

We are wrapping up the bathroom jobs this week at Rio Rosales. I noticed quite a few of the fluorescent light lenses missing or damaged. In the past we would replace the light with a retrofit kit and get rid of the ballast and the lamps. There is 18 lights total in all the bathrooms we are working in. Below is the price if interested in replacing and attached is the submittal for the light kit.

(18) 2x4 ceiling light fixtures replaced with led retrofits \$325.00 each grand total \$5,850.00

Thanks ,

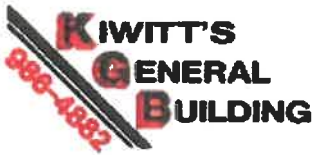

Dustin Sartwell

KIWITT GENERAL BUILDING

805-427-3171

FEATURES & SPECIFICATIONS

INTENDED USE — The BLTR Best-Value Low Profile LED Relight Assembly is a cost effective solution for renovating existing fluorescent troffer and parabolic fixtures while providing upgraded aesthetics and outstanding performance. The BLTR's popular center basket design offers a clean, versatile style, and volumetric distribution. The wide range of lumen packages and control and driver options make the BLTR a great choice for many applications including offices, schools, hospitals, retail spaces and other general lighting applications.

CONSTRUCTION — Universal end brackets are constructed of 22-gauge powder-painted steel and are secured to the host fixture with provided TEK® screws. The driver and light engine assembly is integrated in the BLTR door assembly making this an extremely "simple", time saving, relight solution. The door frame and reflector assembly is made of cold-rolled steel and is painted after fabrication with a matte white powder paint for improved aesthetics and increased light diffusion. Diffuser trim rings provide an attractive mounting for integral sensors as well as adding a decorative element to the luminaire aesthetics.

LED boards and driver are accessible from below.

OPTICS — Volumetric illumination is achieved by creating an optimal mix of light to walls, partitions and vertical and horizontal work surfaces — rendering the interior space, objects and occupants in a more balanced, complimentary luminous environment. High performance extruded acrylic diffusers conceal LEDs and efficiently deliver light in a volumetric distribution. Four diffuser choices available - curved and square designs with linear prisms or a smooth frosted finish.

ELECTRICAL — Long-life LEDs, coupled with high-efficiency drivers, provide superior quantity and quality of illumination for extended service life. 80% LED lumen maintenance at 60,000 hours (L80/60,000).

Non-Configurable BLTR Relight: Generic 0-10 volt dimming driver. Dims to 10%

Configurable BLTR Relight: available in High Efficiency (HE) versions for applications where a lower wattage (over the standard product) is required. High Efficiency versions deliver >130 LPW and can be specified via the Lumen Package designations in the Ordering Information below.

eldoLED driver options deliver choice of dimming range, and choices for control, while assuring flicker-free, low-current inrush, 89% efficiency and low EMI.

Step-level dimming option allows system to be switched to 50% power for compliance with common energy codes while maintaining fixture appearance.

Optional integrated nLight® controls make each luminaire addressable - allowing it to digitally communicate with other nLight enabled controls such as dimmers, switches, nLight AIR RIQ, RES7 occupancy sensors and photo controls. Simply connect all the nLight enabled control devices and the BLTR Relight assembly using standard Cat-5 cabling. Unique plug-and-play convenience as devices and luminaires automatically discover each other and self-commission. Lumen Management: Unique lumen management system (option N80) provides on board intelligence that actively manages the LED light source so that constant lumen output is maintained over the system life, preventing the energy waste created by the traditional practice of over-lighting. Driver disconnect provided where required to comply with US and Canadian codes.

SENSOR — Integrated sensor (individual control): Sensor Switch MSD7ADCX (Passive Infrared (PIR)) or MSDP017ADCX (PIR/Microphonics Dual Tech (PDT)) integrated occupancy sensor/automatic dimming photocell allows the luminaire to power off when the space is unoccupied or enough ambient light is entering the space. See page 4 for more details on the integrated sensor.

Integrated Sensor (nLight Wired Networking): This sensor is nLight-enabled, meaning it has the ability to communicate over an nLight network. When wired, using CAT-5 cabling, with other nLight-enabled sensors, power packs, or WallPods, an nLight control zone is created. Once linked to a Gateway, directly or via a Bridge, the zone becomes capable of remote status monitoring and control via SensorView software. See page 4 for the nLight sensor options.

Integrated Smart Sensor (nLight Air Wireless Platform): The RES7 sensor is nLight AIR enabled, meaning it has the ability to communicate over the wireless nLight control platform. It is available with an automatic dimming photocell, and either a digital PIR or microphonics (PDT) dual technology occupancy sensor. It pairs to other luminaires and wall switches through our mobile app, CLARITY™, which allows for simple sensor adjustment. See page 4 for more details on the Integrated Smart Sensor.

INSTALLATION — After existing fluorescent components are removed from the host housing, universal end brackets are secured in place with TEK® screws. The BLTR's integrated driver and light engine door assembly can then be hinged to the universal end brackets and will hang in place for completion of assembly plug-in wiring. Rotate the doorframe assembly closed and pivot the cam latches to secure the doorframe in place. LED boards include plug-in connectors for easy replacement or servicing. Suitable for damp location installations. Damp location not available with sensor versions.

LISTINGS — UL/cUL Listed for use in fluorescent light fixtures. Installing Relight assemblies per instructions will not impact existing fixture UL listing. Tested to LM80 standards. DesignLights Consortium™ (DLC) Premium qualified product. Not all versions of this product may be DLC Premium qualified. Please check the DLC Qualified Products List at www.designlights.com/DPL to confirm which versions are qualified.

WARRANTY — 5-year limited warranty. Complete warranty terms located at: www.acuitybrands.com/customerresources/terms_and_conditions.aspx

NOTE: Actual performance may differ as a result of end-user environment and application. All values are design or typical values, measured under laboratory conditions at 25 °C. Specifications subject to change without notice.

Catalog Number	ZBLTR4R 40L ADP EZ1 LP840
Notes	
Type	

2BLTR Series LED Relight

2BLTR

2' x 4' Relight
LED



Fit Compatibility:

The 2BLTR Relight Assembly was designed to upgrade recessed 2x4 fixtures, including most parabolic and lensed troffers from all major manufacturers. Dimensional requirements are below, but Lithonia Lighting recommends a trial installation prior to purchasing project quantities.

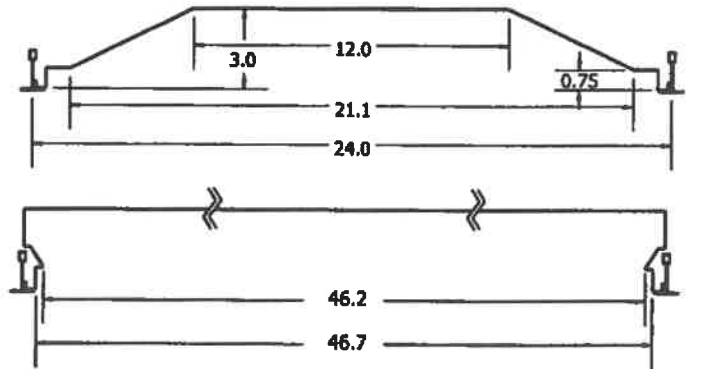

SIDE SECTION

A+ Capable Luminaire

This item is an A+ capable luminaire, which has been designed and tested to provide consistent color appearance and out-of-the-box control compatibility with simple commissioning.

- All configurations of this luminaire meet the Acuity Brands' specification for chromatic consistency
- This luminaire is part of an A+ Certified solution for nLight® control networks when ordered with drivers marked by a **shaded background***
- This luminaire is part of an A+ Certified solution for nLight control networks, providing advanced control functionality at the luminaire level, when selection includes driver and control options marked by a **shaded background***

To learn more about A+, visit www.acuitybrands.com/aphus.

*See ordering tree for details

2BLT4R Volumetric Recessed Lighting 2'x4' Relight



ORDERING INFORMATION

Lead times will vary depending on options selected. Consult with your sales representative.

Example: 2BLT4R 40L ADP EZ1 LP840

2BLT4R		40L		ADP		EZ1	LP840
Series	Air Function	Lumens ²		Diffuser	Voltage	Driver	Color temperature
2BLT4R 2X4 BLTR	(blank) Static (white end brackets for troffers)	Standard efficiency (>100 LPW)	High efficiency ³ (>130 LPW)	AOP Curved, linear prisms ADSM Curved, smooth SDP Square, linear prisms SOSM Square, smooth Diffusers w/ trim rings ADPT Curved, linear prisms ADSMT Curved, smooth SDPT Square, linear prisms SOSAT Square, smooth	(blank) MVOLT 120 120V 277 277V 347 347V ¹⁴	EZ1 eidoLED dims to 1% (0-10 volt dimming) GZ1 Dims to 1% (0-10V dimming) ⁴ GZ10 Dims to 10% (0-10V dimming) ⁴ SLD Step-level dimming ⁷ EOHN On/Off (non-dim)	LP830 82CRI, 3000K LP835 82CRI, 3500K LP840 82CRI, 4000K LP850 82CRI, 5000K LP930 90CRI, 3000K LP935 90CRI, 3500K LP940 90CRI, 4000K LP950 90CRI, 5000K
	A Air supply/return or to maintain black reveal (black end brackets for parabolics) ¹	30L 3000 40L 4000 48L 4800 60L 6000 72L 7200	30LHE 3000 40LHE 4000 48LHE 4800 60LHE 6000 72LHE 7200 85LHE 8500				
	F Flanged Brackets						

nLight Interface	Control ¹¹	Standby Mode	Options
nLight Wired	nLight Wired	NOC Occupancy sensor disabled ¹⁵	EL7L 700 lumen battery pack (Noncompliant with CA T20) ¹⁶
(blank) no nLight [®] interface	(blank) No sensor control		EL14L 1400 lumen battery pack (Noncompliant with CA T20) ¹⁶
N80 nLight with 80% lumen management	NES7 nLight [™] nES 7 PIR Integral occupancy sensor ¹¹	MS07ADCX PIR Integral occupancy sensor with automatic dimming control photocell ¹²	E10WLCP EM Self-Diagnostic battery pack, 10W Constant Power, (Certified in CA Title 20 MAED85) ¹⁵
N80EMG nLight with 80% lumen management. For use with generator supply EM power ⁴	NESPDT7 nLight [™] nES PDT 7 dual technology Integral occupancy control ¹¹		BGTD Bodine Generator Transfer Device ¹⁵
N100 nLight without lumen management	NES7ADCX nLight [™] nES 7 ADCX PIR Integral occupancy sensor with automatic dimming photocell ¹¹	MSDPDT7ADCX PDT Integral occupancy sensor with automatic dimming control photocell ¹²	GLR Fast-blowing fuse ¹⁵
N100EMG nLight without lumen management. For use with generator supply EM power ⁴	NESPDT7ADCX nLight [™] nES PDT 7 dual technology Integral occupancy sensor with automatic dimming photocell ¹¹		GMF Slow-blowing fuse ¹⁵
nLight Wireless	nLight Wireless		NPLT Narrow pallet
(blank) no nLight [®] interface	RES7 nLight AIR PIR Integral occupancy sensor with automatic dimming photocell for Networking Capabilities Individual Control		FAO Field adjustable output ¹⁷
NLTAIR2 nLight AIR Generation 2 enabled ¹	RES7PDT nLight AIR microphonics dual technology occupancy sensor with automatic dimming photocell for Zone Control		USPOM US Point of Manufacture
	R10 nLight AIR radio module without sensor		JP16 Job Pack

Non-Configurable BLT								
Stock	Catalog Description ⁹	UPC	Lumens	Wattage	LPW	Color Temperature	Voltage	Pallet Qty
Stock	2BLT4R 40L ADP LP835	190887550948	3960	32	124	3500K/80 CRI	120-277	26
	2BLT4R 40L ADP LP840	190887550979	4023	32	127	4000K/80 CRI	120-277	26
	2BLT4R 46L ADP LP835	190887550993	4520	38	118	3500K/82 CRI	120-277	26
	2BLT4R 46L ADP LP840	190887551006	4620	38	121	4000K/82 CRI	120-277	26

⁴ Dims to 10%

- Notes**
- Consult factory for airflow data.
 - Approximate lumen output.
 - All versions may not achieve 130+ LPW. Refer to photometry on www.acuitybrands.com.
 - Not available with EL7L or EL14L battery packs.
 - 347 not available with SLD.
 - GZ1, GZ10 not available with any Control or Sensor options.
 - Not available with N80, N80EMG, N100, N100EMG, NLTAIR2, or occupancy control.
 - nLight EMG option requires a connection to existing nLight network. Power is provided from a separate N80 or N100 enabled fixture.
 - Must order with RES7, RES7PDT, or R10 sensor. Only available with EZ1 driver. Not available with 72L, 72LHE, or 85LHE options.
 - Must specify diffuser with trim rings. See sensor options on page 4.
 - Requires N80, N80EMG, N100, or N100EMG.
 - Only available with EZ1 driver option. 0-10V dimming wires not accessible via access plate. Not available with Controls options.
 - Can only be ordered in conjunction with EZ1, NLTAIR2, RES7/RES7PDT. Occupancy sensor disabled at factory but can be re-enabled upon commissioning.
 - Requires BSE labeling. Consult factory for options.
 - Must specify voltage, 120 or 277 with GLR & GMF fusing.
 - GZ1 driver not available with battery pack when specifying 72LHE or 85LHE lumen options. Must use EZ1 driver.
 - Consult factory.

Multiple Diffuser Options

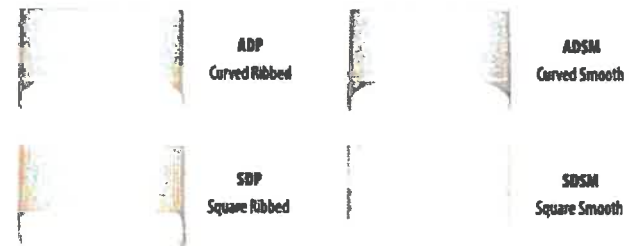

Accessories next page

2BLT4R Volumetric Recessed Lighting 2'x4' Relight

nLight® AIR Control Accessories:
 Order as separate catalog number. Visit www.ecitybrands.com/products/controls/nlightair.

Wall switches	Model number
On/Off single pole	rP0DB [color] G2
On/Off two pole	rP0DB 2P [color] G2
On/Off & raise/lower single pole	rP0DB DX [color] G2
On/Off & raise/lower two pole	rP0DB 2P DX [color] G2
On/Off & raise/lower single pole	rP0DBZ 0XWH G2

Application Guide

2BLT4R — Typically used for lensed troffer installations. Assembly contains white end brackets and is supplied with white trim strips for use in closing gaps down fixture sides (installer's choice - not required).

**Note: This kit will fit in Lithonia's Avante non-air fixture.*



2BLT4R A — Typically used for parabolic installations with black reveal. Assembly contains black end brackets to match black reveal around host housing. Does not interfere with host housing air supply/return if present (along fixture sides).



Series / Detection		Power Supply ¹	Occupancy Detection	Lens (Required)	Operating Mode	Generation
RCMS	nLight AIR occupancy and daylight sensor	[blank]	Power Supply ordered separately	[blank] PIR Detection	[BLANK] None	G2 Generation 2 compatibility
		PS 150	Standard 150 mA Power Supply	PDT ² Dual Tech PIR/Microphonics	AR Auxiliary Relay	
				10 Large Motion/ Extended Range 360°		
				9 Small Motion/ Extended Range 360°		
				6 High Bay 360° Lens		

Notes

1 RCMS requires low voltage power from either RPP20 DS 24V G2 or PS150.



2BLT4R Volumetric Recessed Lighting 2'x4' Relight

Replacement Parts: Order as separate catalog number.

DBLTR48 ADP LENS ASSEMBLY	4 ft. replacement lens (trims included)
DBLTR48 SDP LENS ASSEMBLY	4 ft. replacement lens (trims included)
DBLTR48 ADSM LENS ASSEMBLY	4 ft. replacement lens (trims included)
DBLTR48 SDSM LENS ASSEMBLY	4 ft. replacement lens (trims included)
DBLTR48 ADPT LENS ASSEMBLY	4 ft. replacement lens (trims included)
DBLTR48 SDPT LENS ASSEMBLY	4 ft. replacement lens (trims included)
DBLTR48 ADSMT LENS ASSEMBLY	4 ft. replacement lens (trims included)
DBLTR48 SDSMT LENS ASSEMBLY	4 ft. replacement lens (trims included)
DBLTR48 ADPT SENSOR LENS ASSEMBLY	4 ft. replacement lens (trims included)
DBLTR48 SDPT SENSOR LENS ASSEMBLY	4 ft. replacement lens (trims included)
DBLTR48 ADSMT SENSOR LENS ASSEMBLY	4 ft. replacement lens (trims included)
DBLTR48 SDSMT SENSOR LENS ASSEMBLY	4 ft. replacement lens (trims included)
U10528A	4 ft. replacement troffer trim strip

2BLT4R Volumetric Recessed Lighting 2'x4' Relight

Sensor Options					
Option	Automatic Dimming Photocell	Occupancy Sensing		nLight Wired Networking	nLight AIR Networking
		PIR	PDT		
MSD7ADCX	X	X			
MSDPDT7ADCX	X		X		
NES7		X		X	
NES7ADCX	X	X		X	
NESPDT7			X	X	
NESPDT7ADCX	X		X	X	
RES7	X	X			X
RESPDT7	X	X	X		X

Integrated Sensor with Individual Control

The MSD7ADCX PIR occupancy sensor/automatic dimming photocell is ideal for areas without obstructions and where daylight harvesting may be desired. Suggested applications include, but not limited to, hallways, corridors, storage rooms, and breakrooms or other areas where people are typically moving.

The MSDPDT7ADCX PIR/Microphonics Dual Tech occupancy sensor/automatic dimming photocell is ideal for areas with obstructions and where daylight harvesting is desired. Suggested applications include, but not limited to, open offices, private offices, classrooms, public restrooms, and conference rooms.

Sequence of Operation

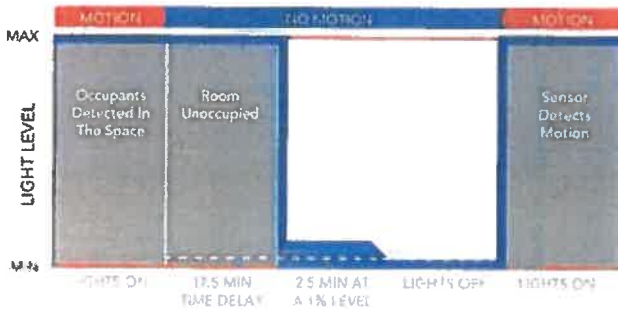

*The presetting on the automatic dimming photocell is 5fc.

Sensor Coverage Pattern Mini 360° Lens

- Recommended for walking motion detection from mounting heights between 8 ft (2.44 m) and 20 ft (6.10 m)
- Initial detection of walking motion along sensor axes at distances of 2x the mounting height up to 15 ft (4.57 m) and
- 1.75x up to 20 ft (6.10 m).
- Provides 12 ft (3.66 m) radial detection of small motion when mounted at 9 ft (2.74 m)
- Initial detection will occur earlier when walking across sensor's field of view than when walking directly at sensor

9 FT Mounting

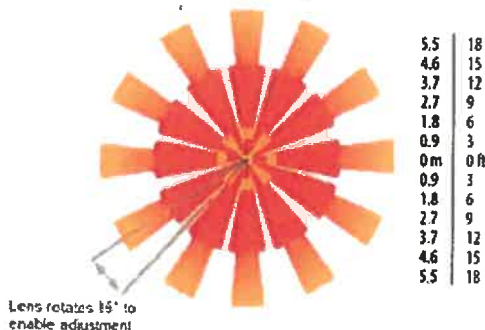

Lens rotates 15° to enable adjustment

Basic nLight Zone

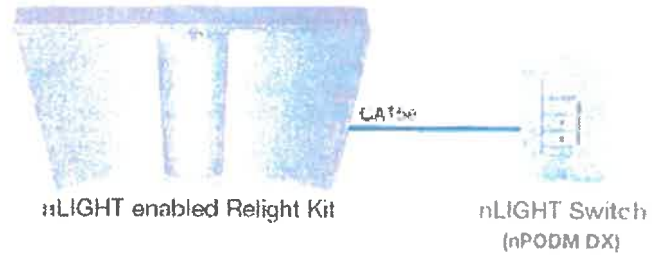

nLight Wired Networking

The nES 7 is ideal for small rooms without obstructions or areas with primarily walking motion. Ideal areas include hallways, corridors, storage rooms, and breakrooms. Additionally, the NES7ADCX includes an integrated photocell, which enables daylight harvesting controls.

For areas like restrooms, private offices, open offices, conference rooms or any space with obstructions, the nES PDT 7 dual technology sensor is recommended. The nES PDT 7 utilizes both PIR (passive infrared) and Microphonics technologies to detect occupancy. Additionally, the NESPDT7ADCX includes an integrated photocell, which enables daylight harvesting controls which is ideal for areas where windows are present.

Sequence of Operation

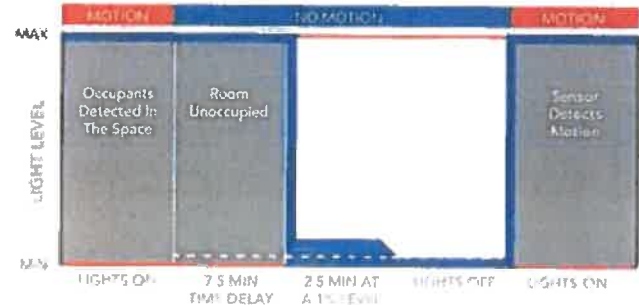

*The presetting on the automatic dimming photocell is 5fc.

nLight AIR Wireless

nLight AIR is the ideal solution for retrofit or new construction spaces where adding additional wiring can be labor intensive and costly. nLight AIR is available with or without an integral sensor. The integrated rES 7 or rES7PDT smart sensor is part of each luminaire in the nLight AIR network, which can be grouped to control multiple luminaires. The granularity of control with the digital PIR occupancy detection and daylight sensing makes a great solution for any application.

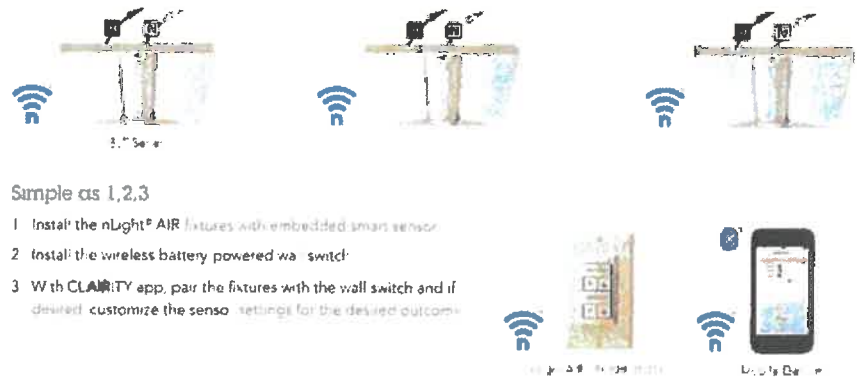

2BLT4R Volumetric Recessed Lighting 2'x4' Relight

PHOTOMETRICS

2BLT4R 40L ADP LP835, 3945 delivered lumens, test no. LTL28918P417, tested in accordance to IESNA LM-79

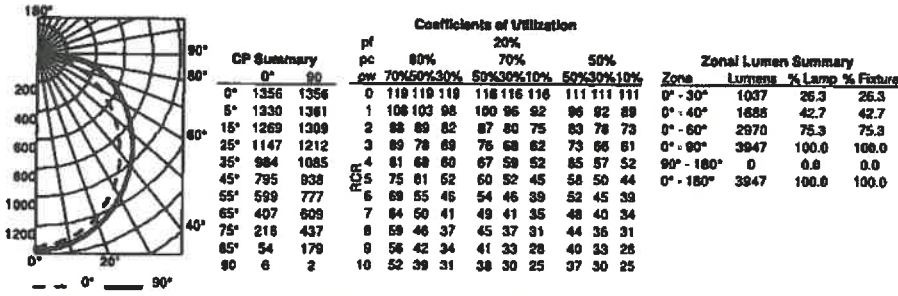

2BLT4R 48L ADP LP835, 5121 delivered lumens, test no. LTL28918P421, tested in accordance to IESNA LM-79

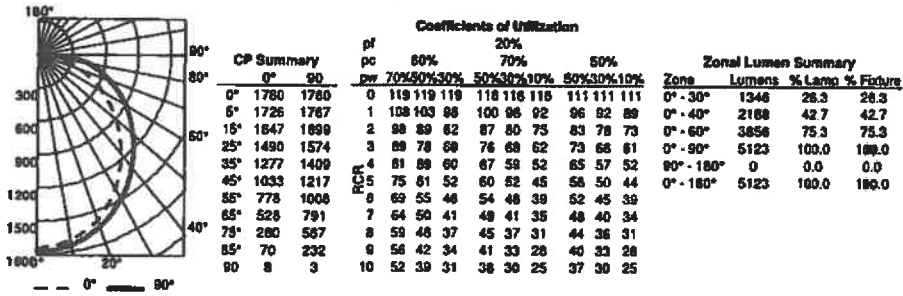

Performance Data			
Lumen Package	Lumens	Input Watts	LPW
30L ADP LP830	2832	23	125
30L ADP LP835	2932	23	129
30L ADP LP840	2979	23	131
30L ADP LP850	3064	23	135
40L ADP LP830	3825	31	123
40L ADP LP835	3960	31	128
40L ADP LP840	4023	31	130
40L ADP LP850	4138	31	134
48L ADP LP830	4743	38	126
48L ADP LP835	4910	38	130
48L ADP LP840	4989	38	133
48L ADP LP850	5131	38	136
60L ADP LP830	5753	46	124
60L ADP LP835	5956	46	128
60L ADP LP840	6051	46	130
60L ADP LP850	6224	46	134
72L ADP LP830	6928	59	118
72L ADP LP835	7173	59	122
72L ADP LP840	7287	59	124
72L ADP LP850	7495	59	128

HE Performance Data			
Lumen Package	Lumens	Input Watts	LPW
30LHE ADP LP830	2971	22	133
30LHE ADP LP835	3076	22	138
30LHE ADP LP840	3125	22	140
30LHE ADP LP850	3214	22	144
40LHE ADP LP830	3906	29	134
40LHE ADP LP835	4044	29	138
40LHE ADP LP840	4109	29	141
40LHE ADP LP850	4226	29	145
48LHE ADP LP830	4561	34	135
48LHE ADP LP835	4722	34	139
48LHE ADP LP840	4798	34	142
48LHE ADP LP850	4935	34	146
60LHE ADP LP830	5636	43	132
60LHE ADP LP835	5835	43	137
60LHE ADP LP840	5928	43	139
60LHE ADP LP850	6098	43	143
72LHE ADP LP830	6836	52	132
72LHE ADP LP835	7078	52	137
72LHE ADP LP840	7191	52	139
72LHE ADP LP850	7396	52	143
85LHE ADP LP830	7801	61	127
85LHE ADP LP835	8076	61	131
85LHE ADP LP840	8205	61	133
85LHE ADP LP850	8440	61	137

9.16



Agenda Item Details

Meeting	Oct 21, 2020 - RSD Regular Board Meeting
Category	9. Consent
Subject	9.16 Approval of Change Order from MM Mechanical for Project #20-12L for work at Rio Real, Rio Del Valle and Rio Rosales
Access	Public
Type	Action (Consent)
Fiscal Impact	Yes
Dollar Amount	12,347.78
Budgeted	Yes
Budget Source	Measure L Funds
Recommended Action	It is recommended that the Board approve Change Order #1 from MM Mechanical, Inc.

Public Content

Speaker:

Wael Saleh, Assistant Superintendent, Business Services

Rationale:

This change order is for the added scope of work for Project No. 20-12L for the Touchless Plumbing Fixture Replacements at Rio Real, Rio Del Valle and Rio Rosales by MM Mechanical. The changes include the following:

- Plumbing Issues Found/Corrected during Touchless Repairs at Rio Real	\$6,653.31
- Plumbing Issues found/repared during Touchless Repairs at Rio Del Valle	\$3,608.43
- Plumbing Issues found/repared during Touchless repairs at Rio Rosales	<u>\$2,086.04</u>
Total:	\$12,347.78

RIO REAL:

1. Upgrade new toilet seat hold down bolts to stainless steel from plastic
2. Replace 12 angle stop shut off valves
3. Replacement 2 flush valves
4. Reset 4 toilets due to base gasket leak and
5. Replace flushometer vacuum breaker
6. Replace P Trap
7. Includes Other misc. items

Rio Del Valle

1. Replace Toilet Spout
2. Replace 6 flush valve O Rings

3. Repair & Replace 4 closet rings on toilet flush valves
4. Replace 14 vacuum breakers
5. Replace 4 vacuum breaker diaphragms
6. Replace 1 flushometer tail piece
7. Replace 4 Angle Stops
8. Replace 1 flush valve
9. Includes Other misc. items

Rio Rosales

1. Replace 4 Angle Stops
2. Replace 4 closet Flange Gaskets Kist
3. Replace for toilet wax rings
4. Replace toilet hold down bolts/assembly
5. Includes other misc. items

20-12L COR#1 for MM for October Board Meeting 9 28 2020.pdf (603 KB)

Administrative Content

Executive Content

Our adopted rules of Parliamentary Procedure, Robert's Rules, provide for a consent agenda listing several items for approval of the Board by a single motion. Most of the items listed under the consent agenda have gone through Board subcommittee review and recommendation. Documentation concerning these items has been provided to all Board members and the public in advance to assure an extensive and thorough review. Items may be removed from the consent agenda at the request of any board member.

Balfour Beatty Construction

Rio School District
1800 Solar, 3rd Floor
Oxnard, CA 93030

September 30, 2020

Attn: Dr. Puglisi

Subject: Rio Lindo Elementary School
Rio School District
Oxnard, CA

Re: Project 20-12L COVID 19 Touchless Plumbing Fixture Replacements at Rio Real, Rio Del Valle & Rio Rosales.
MM Mechanical, Inc.
Recommendation to Approve CO #1 to MM Mechanical, Inc.

Dear Dr. Puglisi,

Please accept this letter as recommendation to request approval for CO #1 to MM Mechanical, Inc. for Added & Deleted scope of work items at the above Project, and as amendment to their contract. Scope change to the project is as follows;

PCO No.	GC No.	Description	Reason	Cost/Credit
1	MM	Additional Plmg Repairs at Rio Real	Plmg Issues Found/Corrected During Touchless Repairs	\$ 6,653.31
2	MM	Additional Plmg Repairs at Rio Del Valle	Plmg Issues Found/Repaired During Touchless Repairs	\$ 3,608.43
3	MM	Additional Plmg Repairs at Rio Rosales	Plmg Issues Found/Repaired During Touchless Repairs	\$ 2,086.04

Total CO #1	\$ 12,347.78
Previous Approved CO's	\$ 0
Original Contract	\$197,762.00
Revised Contract	<u>\$210,109.78</u>

Should you have any questions, please contact me at any time.

Respectfully,



Keith Henderson
Senior Project Manager, Balfour Beatty

cc. Wael Saleh, Rio School District
Dennis Kuykendall, Balfour Beatty
Jesus Muguerza Ibarra

**Rio School District
1800 Solar, 3rd Floor
Oxnard, Ca 93030**

**CO 1
09-30-2020**

PROJECT NO: RSD 20-12L

CO NO: 1

PROJECT NAME: COVID 19 Touchless Plumbing Fixture Replacements at Rio Real, Rio Del Valle & Rio Rosales

CONTRACTOR: MM Mechanical, Inc.

SCOPE OF WORK: SEE ATTACHED

COST:

Original Contract Amount	\$ 197,762.00
Previous Approved Change Orders	\$ 0.00
This Change Order	\$ 12,347.78
Adjusted Contract Amount	\$ 210,109.78

TIME:

Original Contract Completion Date	October 2020
Previously Approved Completion Extension Days	0
Completion Days Extension this Change Order	0
Adjusted Contract Completion Date	October 2020

IT IS AGREED BY THE CONTRACTOR THAT THE AMMENDED CONTRACT AMOUNT AND/OR TIME, IF ANY, INCLUDES FULL AND COMPLETE EQUITABLE ADJUSTMENT AND COMPENSATION FOR ALL CONTRACT WORK AND EXTRA WORK PERFORMED ON THE PROJECT INCLUDING BUT NOT LIMITED TO CHANGES, DIFFERING SITE CONDITIONS, SUSPENSIONS, DELAYS, RESCHEDULING, ACCELERATION, IMPACT AND EXTENDED OVERHEAD AS IT RELATES SPECIFICALLY TO ITEMS OF THE ATTACHED LISTING. CONTRACTOR HEREBY WAIVES ANY AND ALL RIGHT TO ADDITIONAL COMPENSATION OR TIME ARISING OUT OF THE WORK SPECIFIC TO ITEMS OF THE ATTACHED LISTING, AND HEREBY ACKNOWLEDGES AND AGREES THAT THE AMOUNT SHOWN ABOVE CONSTITUTES PAYMENT IN FULL ACCORDING TO THE CONTRACT DOCUMENTS.

EXCEPT TO THE EXTENT THE CONTRACT HAS BEEN MODIFIED BY PREVIOUSLY ISSUED DISTRICT CHANGE ORDERS, AND FURTHER MODIFIED BY THIS CHANGE ORDER, THE CONTRACT REMAINS IN FULL FORCE AND EFFECT.

RIO SCHOOL DISTRICT

Contractor: MM Mechanical, Inc.

By _____

By _____

Date _____

Date _____

District Architect; N/A

District PM/CM; Balfour Beatty Construction

By _____

By  _____

Date _____

Date 9/28/2020 _____

PCO to Contract
Rio Bid RSD #20-12L

Rio School District

Project No RSD 20-12L

COVID 19 Touchless Pimg Fixture R & R
Rio Real, Rio Del Valle, Rio Rosales

CO #1

9/30/2020

Original Contract

\$ 197,762.00

PCO No.	GC No.	Description	Reason	Cost/Credit
1	MM	Additional Pimg Repairs at Rio Real	Pimg Issues Found/Corrected During Touchless Repair	\$ 6,653.31
2	MM	Additional Pimg Repairs at Rio Del Valle	Pimg Issues Found/Repaired During Touchless Repairs	\$ 3,608.43
3	MM	Additional Pimg Repairs at Rio Rosales	Pimg Issues Found/Repaired During Touchless Repairs	\$ 2,086.04

Total CO #1	\$ 12,347.78
Previous Approved CO's	\$ -
Original Contract	\$ 197,762.00
Revised Contract	\$ 210,109.78

20-12L COR#1
RIO REAL

M/M MECHANICAL, INC.
1027 CINDY LANE
CARPINTERIA CA 93013-2905
805-745-1126

Contract Invoice

Invoice#: 17914

Date: 09/25/2020

License: 774231

Billed To: RIO SCHOOL DISTRICT
2500 E VINEYARD AVE
SUITE 100
OXNARD CA 93036

Project: RIO SCHOOLS COVID PREPAREDNESS
1800 SOLAR DRIVE
OXNARD CA 93030

Due Date: 10/25/2020

Terms:

Order#

Description	Amount
RIO REAL MISC PLUMBING REPAIRS. REPAIRED LEAKS AND BROKEN VALVES WHILE ONSITE FOR COVID TOUCHLESS INSTALL.	
SLOAN ROYAL FLUSHOMETER 2 @ 156.32	312.64
APHRAM SLAON 1 @ 12.99	12.99
SLAON TOILET SPUDS 2 @ 16.21	32.42
CLOSET RING EXTENSIONS 8 @ 17.22	137.76
SILICONE TUBES 3 @ 8	24.00
1/2" COMPRESSION X 3/8 ANGLE STOPS 15 @ 12.34	185.10
1 1/2" BRASS P TRAP 1 @ 21.20	21.20
SLOAN VAC BREAKER 1 @ 19.45	19.45
PLUMBER 48 HRS @ 105	5,040.00
OH&P 15%	867.75
NO CHARGE FOR MISC HARDWARE USED	

A service charge of 0.00 % per annum will be charged on all amounts overdue on regular statement dates.

Thank you for your prompt payment!

Non-Taxable Amount:	6,653.31
Taxable Amount:	0.00
Sales Tax:	0.00
Amount Due	6,653.31

20-12L col #1
RIO REAL

M/M MECHANICAL, INC.

1027 CINDY LANE, CARPINTERIA, CA 93013-2905
T: 805/745-1126 FX: 805/745-1116

WORK ORDER # 29003

MM PCO # 1166

CUSTOMER INFORMATION

NAME: _____
ADDRESS: _____
CITY: _____ STATE: _____ ZIP: _____
PHONE: () _____
CUSTOMER ORDER #: _____

JOB INFORMATION

JOB NAME/NUMBER/LOT #: Rio Real
JOB LOCATION: class rooms 14-19
JOB PHONE: (replaced angle stop
ORDERTAKEN BY: Jose
ORDER DATE: _____ DATE COMPLETED: 8-28-20

TO BE QUOTED EXTRA/T&M WORK M/M WARRANTY OTHER WARRANTY

QTY.	MATERIAL	PRICE	AMOUNT	DESCRIPTION OF WORK
6	1/2 x 3/8 Key less Angle stop			shut off water off to class room replace damage angle stop checked for leak
				OTHER CHARGES
			1	Truck
				LABOR
				HRS. RATE AMOUNT
				Jose .5
				Richard 2
Work ordered by _____				
Signature _____ <small>I hereby acknowledge the satisfactory completion of the above described work and agree to pay in full all costs associated.</small>				

20-12L COR #1
RDY

M/M MECHANICAL, INC.
1027 CINDY LANE
CARPINTERIA CA 93013-2905
805-745-1126

Contract Invoice

Invoice#: 17911

Date: 09/25/2020

License: 774231

Billed To: RIO SCHOOL DISTRICT
2500 E VINEYARD AVE
SUITE 100
OXNARD CA 93036

Project: RIO SCHOOLS COVID PREPAREDNESS
1800 SOLAR DRIVE
OXNARD CA 93030

Due Date: 10/25/2020

Terms:

Order#

Description	Amount
<u>RIO DE VALLE MISC REPAIRS TO EXISTING PLUMBING</u> <u>DURING COVID FIXTURE TOUCHLESS INSTALLS</u>	
1/2" IPS X COMP ANGLE STOP 7 @ 13.10	91.70
SLOAN FLUSH VLV 1 @ 156.32	156.32
SLOAN VAC BREAKER 9 @ 19.45	175.05
FLUSH VLV TAILPIECE 4 @ 12.60	50.40
TOILET SPUDS 4 @ 16.21	64.84
DIAPHRAM REPAIR KITS 4 @ 12.99	51.96
FLUSH VLV TOP O RING 6 @ 2.25	13.50
1 1/2" SLIP WASHER BRASS 4 @ 3.50	14.00
PLUMBER 24 HRS @ 105	2,520.00
OH&P 15%	470.66

A service charge of 0.00 % per annum will be charged on all amounts overdue on regular statement dates.

Thank you for your prompt payment!

Non-Taxable Amount:	3,608.43
Taxable Amount:	0.00
Sales Tax:	0.00
Amount Due	3,608.43

20-12L COR#1
RDY

M/M MECHANICAL, INC.

1027 CINDY LANE, CARPINTERIA, CA 93013-2905
PH: 805/745-1126 FX: 805/745-1116

WORK ORDER # 29005

MM PCO # 1166

CUSTOMER INFORMATION

NAME: _____
ADDRESS: _____
CITY: _____ STATE: _____ ZIP: _____
PHONE: () _____
CUSTOMER ORDER #: _____

JOB INFORMATION

JOB NAME/NUMBER/LOT #: Risa Del Valle
JOB LOCATION: Womens restroom (Gym)
JOB PHONE: replace part in flush valve
ORDERTAKEN BY: Jose
ORDER DATE: _____ DATE COMPLETED: 8-26-20

TO BE QUOTED EXTRA/T&M WORK M/M WARRANTY OTHER WARRANTY

QTY.	MATERIAL	PRICE	AMOUNT	DESCRIPTION OF WORK
9	vacuum breaker			replace high stop in building #37
9	1/2 slip nut washer			
3	flush valve seal piece			replace high stop to lav in restroom next to library
3	Porlet spools			
1	diaphragm repair kit			replace vacuum breaker diaphragm & washer in restroom in Gym building
3	1/2 IPS x 3/8 comp Angle stop			Tested for leak
				OTHER CHARGES
			1	Truck

LABOR	HRS.	RATE	AMOUNT
Jose	2		
Richard	2		
Ricky	8		

Work ordered by _____

Signature _____
I hereby acknowledge the satisfactory completion of the above described work and agree to pay in full all costs associated

20-12L cor#1
RIO ROSALES

M/M MECHANICAL, INC.
1027 CINDY LANE
CARPINTERIA CA 93013-2905
805-745-1126

Contract Invoice

Invoice#: 17913

Date: 09/25/2020

License: 774231

Billed To: RIO SCHOOL DISTRICT
2500 E VINEYARD AVE
SUITE 100
OXNARD CA 93036

Project: RIO SCHOOLS COVID PREPAREDNESS
1800 SOLAR DRIVE
OXNARD CA 93030

Due Date: 10/25/2020

Terms:

Order#

Description	Amount
RIO ROSALES MISC COVID PLUMING REPAIRS REPLACED BROKEN ANGLE STOPS AND REPAIRED LEAKING TOILET DRAIN CONNECTIONS PLUMBER 16 HRS @ 105	1,680.00
AX RINGS 3 @ 3	9.00
BOLT CAPS 3 @ 2.89	8.67
1/2 COMP X 3/8 COMP ANGL STOPS 4 @ 12.34	49.36
CLOSET FLAGNE GASKET KITS 4 @ 18.63	66.92
OH&P 15%	272.09

A service charge of 0.00 % per annum will be charged on all amounts overdue on regular statement dates.

Thank you for your prompt payment!

Non-Taxable Amount:	2,086.04
Taxable Amount:	0.00
Sales Tax:	0.00
Amount Due	2,086.04

20-12L cor #1
RIO ROSALES

M/M MECHANICAL, INC.

1027 CINDY LANE, CARPINTERIA, CA 93013-2905
TEL: 805/745-1126 FX: 805/745-1116

WORK ORDER # 29013

MM PCO # 1166

CUSTOMER INFORMATION

JOB INFORMATION

NAME: _____

JOB NAME/NUMBER/LOT #: Rio Rosales

ADDRESS: _____

JOB LOCATION: _____

CITY: _____ STATE: _____ ZIP: _____

JOB PHONE: () _____

PHONE: () _____

ORDERTAKEN BY: Jesse

CUSTOMER ORDER #: _____

ORDER DATE: _____ DATE COMPLETED: 9-8-20

TO BE QUOTED EXTRA/T&M WORK M/M WARRANTY OTHER WARRANTY

QTY.	MATERIAL	PRICE	AMOUNT	DESCRIPTION OF WORK
4	1/2 comp x 3/8 conc tough stop			replace tough stop that were leaking
4	closet flange gasket kit			replaced water closet flange gasket that were leaking
OTHER CHARGES				
			1	Tack
LABOR				
				HRS. RATE AMOUNT
				Jesse 2
				Wick 2
				Richard 2
				Ricky 2

Work ordered by _____

Signature _____
I hereby acknowledge the satisfactory completion of the above described work and agree to pay in full all costs associated

9.17



Agenda Item Details

Meeting	Oct 21, 2020 - RSD Regular Board Meeting
Category	9. Consent
Subject	9.17 Approval of Resolution 20/21-16 for the Notice of Completion of Structural Steel by RND Contractors, Inc. at Rio Del Sol
Access	Public
Type	Action (Consent)
Recommended Action	It is recommended that the Board approve the resolution for the Notice of Completion by RND Contractors, Inc. at Rio Del Sol.

Public Content

Speaker:
Wael Saleh, Assistant Superintendent, Business Services

Rationale:

It is requested that the Board approve the issuance of the Notice of Completion for work related to RSD Project 19-0068-015, at Rio Del Sol Steam for the Bid Package for Structural Steel by RND Contractors, Inc.

RND NOC.pdf (93 KB)

Resolution 20-21-16 NOC RND (1).pdf (109 KB)

Administrative Content

Executive Content

Our adopted rules of Parliamentary Procedure, Robert's Rules, provide for a consent agenda listing several items for approval of the Board by a single motion. Most of the items listed under the consent agenda have gone through Board subcommittee review and recommendation. Documentation concerning these items has been provided to all Board members and the public in advance to assure an extensive and thorough review. Items may be removed from the consent agenda at the request of any board member.

Balfour Beatty Construction

Rio School District
1800 Solar Drive, 3rd Floor
Oxnard, CA 93030
Attn; Dr. Puglisi

October 2, 2020

Subject: Measure L Projects
Rio School District
Oxnard, CA

Re: Project #19-0068-015 Rio Del Sol, STEAM Academy, Building C
Recommendation to Request Board Approval for Issuance of Notice of Completion
Bid Package #3 Structural Steel

Dear Dr. Puglisi,

Please accept this letter as recommendation to request Board approval for issuance of the Notice of Completion for work related to RSD Project #19-0068-015 Rio Del Sol, STEAM Academy, Building C. All contract installation requirements have been satisfied by RND Contractors Inc. for Bid Package #3 Structural Steel. The final contract amount is as follows;

RND Contractors Inc. Base Agreement	\$ 2,249,000.00
RND Contractors Inc. Total Change Order Amount	\$ 29,631.63
FINAL Cost	\$ 2,278,631.63

Should you have any questions, please contact me at any time.

Respectfully,



Jesus Muguerza Ibarra
Assistant Project Manager, Balfour Beatty

cc. Wael Saleh, Rio School District
Dennis Kuykendall, Balfour Beatty

**RIO SCHOOL DISTRICT
RESOLUTION NO. 20/21-16**

**NOTICE OF COMPLETION OF BID PACKAGE #3 STRUCTURAL STEEL
RIO DEL SOL BY RND CONTRACTORS, INC.**

WHEREAS, pursuant to RSD Project No.19-0068-015, the Rio School District (“District”) contracted with RND Contractors, Inc. for the Structural Steel (Bid Package #3) at Rio Del Sol STEAM School; and

WHEREAS, Contractor subsequently commenced the work on Project No. 19-0068-015; and

WHEREAS, on October 2, 2020, the project construction manager confirmed that the work for Project has been closed and certified the job was complete in accordance with the plans and specifications; and

WHEREAS, District has now determined that a Notice of Completion can be filed, attached hereto as Exhibit A and incorporated herein by reference;

NOW, THEREFORE, be it hereby resolved that:

1. The foregoing recitals are true and correct.
2. The Board hereby accepts the Notice of Completion for Project No. 19-0068-015. The Board delegates authority to the Superintendent and the Assistant Superintendent of Business Services or their designee to ensure that the Notice of Completion is filed with the Office of the Ventura County Recorder.

PASSED AND ADOPTED by the Board of Education at a regular meeting held on the 21st day of October, 2020 by the following vote on roll call:

AYES:

NOES:

ABSENT:

ABSTAIN:

Linda Armas, President of the Board of
Trustees

9.18



Agenda Item Details

Meeting	Oct 21, 2020 - RSD Regular Board Meeting
Category	9. Consent
Subject	9.18 Approval of Resolution 20/21-17 for the Notice of Completion for Standard Drywall at Rio Del Sol
Access	Public
Type	Action (Consent)
Recommended Action	It is recommended that the Board approve the resolution for the Notice of Completion by Standard Drywall at Rio Del Sol.

Public Content

Speaker:
Wael Saleh, Assistant Superintendent, Business Services

Rationale:

It is requested that the Board approve the issuance of the Notice of Completion for work related to RSD Project 19-0068-015, at Rio Del Sol Steam by Standard Drywall, Inc. for Bid Package #4, Metal Framing, Rough Framing, Steel Frames and Doors, Wood Doors, and Finish Hardware. The Project Manager has confirmed that all contract installation requirements have been satisfied by Standard Drywall, Inc.

Standard Drywall NOC.pdf (93 KB)

Resolution 20-21-17 NOC SDI (3).pdf (108 KB)

Administrative Content

Executive Content

Our adopted rules of Parliamentary Procedure, Robert's Rules, provide for a consent agenda listing several items for approval of the Board by a single motion. Most of the items listed under the consent agenda have gone through Board subcommittee review and recommendation. Documentation concerning these items has been provided to all Board members and the public in advance to assure an extensive and thorough review. Items may be removed from the consent agenda at the request of any board member.

Balfour Beatty Construction

Rio School District
1800 Solar Drive, 3rd Floor
Oxnard, CA 93030
Attn; Dr. Puglisi

October 2, 2020

Subject: Measure L Projects
Rio School District
Oxnard, CA

Re: Project #19-0068-015 Rio Del Sol, STEAM Academy, Building C
Recommendation to Request Board Approval for Issuance of Notice of Completion
Bid Package #4 Metal Framing, Rough Framing, Steel Frames and Doors, Wood Doors
and Finish Hardware

Dear Dr. Puglisi,

Please accept this letter as recommendation to request Board approval for issuance of the Notice of Completion for work related to RSD Project #19-0068-015 Rio Del Sol, STEAM Academy, Building C. All contract installation requirements have been satisfied by Standard Drywall, Inc. for Bid Package #4 Metal Framing, Rough Framing, Steel Frames and Doors, Wood Doors and Finish Hardware. The final contract amount is as follows;

Standard Drywall, Inc. Base Agreement	\$ 2,605,454.00
Standard Drywall, Inc. Total Change Order Amount	\$ 35,253.00
FINAL Cost	\$ 2,640,707.00

Should you have any questions, please contact me at any time.

Respectfully,



Jesus Muguerza Ibarra
Assistant Project Manager, Balfour Beatty

cc. Wael Saleh, Rio School District
Dennis Kuykendall, Balfour Beatty

**RIO SCHOOL DISTRICT
RESOLUTION NO. 20/21-17**

**NOTICE OF COMPLETION OF BID PACKAGE #14 METAL FRAMING
FOR RIO DEL SOL BY STANDARD DRYWALL, INC.**

WHEREAS, pursuant to RSD Project No. 19-0068-015, the Rio School District (“District”) contracted with Standard Drywall, Inc. for the Metal Framing (Bid Package #14) at Rio Del Sol STEAM School; and

WHEREAS, Contractor subsequently commenced the work on Project No. 19-0068-015; and

WHEREAS, on October 2, 2020, the project construction manager confirmed that the work for Project has been closed and certified the job was complete in accordance with the plans and specifications; and

WHEREAS, District has now determined that a Notice of Completion can be filed, attached hereto as Exhibit A and incorporated herein by reference;

NOW, THEREFORE, be it hereby resolved that:

1. The foregoing recitals are true and correct.
2. The Board hereby accepts the Notice of Completion for Project No. 19-0068-015. The Board delegates authority to the Superintendent and the Assistant Superintendent of Business Services or their designee to ensure that the Notice of Completion is filed with the Office of the Ventura County Recorder.

PASSED AND ADOPTED by the Board of Education at a regular meeting held on the 21st day of October, 2020 by the following vote on roll call:

AYES:

NOES:

ABSENT:

ABSTAIN:

Linda Armas, President of the Board of
Trustees

9.19



Agenda Item Details

Meeting	Oct 21, 2020 - RSD Regular Board Meeting
Category	9. Consent
Subject	9.19 Approval of Resolution 20/21-18 for the Notice of Completion of Finish Carpentry and Architectural Woodwork by K&Z Cabinet Co., Inc. at Rio Del Sol
Access	Public
Type	Action (Consent)
Recommended Action	It is recommended that the Board approve the resolution for the Notice of Completion by K&Z Cabinet Co., Inc. at Rio Del Sol.

Public Content

Speaker:
Wael Saleh, Assistant Superintendent, Business Services

Rationale:

It is requested that the Board approve the issuance of the Notice of Completion for work related to RSD Project 19-0068-015, at Rio Del Sol Steam for the Bid Package for Finish Carpentry and Architectural Woodwork by K&Z Cabinet Co., Inc. The Project Manager has confirmed that all contract installation requirements have been satisfied by K&Z Cabinet Co., Inc.

[K and Z NOC.pdf \(94 KB\)](#)

[Resolution 20-21-18 NOC K&Z.pdf \(111 KB\)](#)

Administrative Content

Executive Content

Our adopted rules of Parliamentary Procedure, Robert's Rules, provide for a consent agenda listing several items for approval of the Board by a single motion. Most of the items listed under the consent agenda have gone through Board subcommittee review and recommendation. Documentation concerning these items has been provided to all Board members and the public in advance to assure an extensive and thorough review. Items may be removed from the consent agenda at the request of any board member.

Balfour Beatty Construction

Rio School District
1800 Solar Drive, 3rd Floor
Oxnard, CA 93030
Attn: Dr. Puglisi

October 2, 2020

Subject: Measure L Projects
Rio School District
Oxnard, CA

Re: Project #19-0068-015 Rio Del Sol, STEAM Academy, Building C
Recommendation to Request Board Approval for Issuance of Notice of Completion
Bid Package #5 Finish Carpentry and Architectural Woodwork

Dear Dr. Puglisi,

Please accept this letter as recommendation to request Board approval for issuance of the Notice of Completion for work related to RSD Project #19-0068-015 Rio Del Sol, STEAM Academy, Building C. All contract installation requirements have been satisfied by K&Z Cabinet Co., Inc. for Bid Package #5 Finish Carpentry and Architectural Woodwork. The final contract amount is as follows;

K&Z Cabinet Co., Inc. Base Agreement	\$	378,470.00
K&Z Cabinet Co., Inc. Total Change Order Amount	\$	(4,000.30)
FINAL Cost	\$	374,469.70

Should you have any questions, please contact me at any time.

Respectfully,



Jesus Muguerza Ibarra
Assistant Project Manager, Balfour Beatty

cc. Wael Saleh, Rio School District
Dennis Kuykendall, Balfour Beatty

RIO SCHOOL DISTRICT

RESOLUTION NO. 20/21-18

**NOTICE OF COMPLETION OF BID PACKAGE #5
FINISH CARPENTRY AND ARCHITECTURAL WOODWORK BY
K&Z CABINET CO., INC. AT RIO DEL SOL**

WHEREAS, pursuant to RSD Project No. 19-0068-015, the Rio School District (“District”) contracted with K&Z Cabinet Co., Inc. for the Finish Carpentry and Architectural Woodwork (Bid Package #5) at Rio Del Sol STEAM School; and

WHEREAS, Contractor subsequently commenced the work on Project No. 19-0068-015; and

WHEREAS, on October 2, 2020, the project construction manager confirmed that the work for Project has been closed and certified the job was complete in accordance with the plans and specifications; and

WHEREAS, District has now determined that a Notice of Completion can be filed, attached hereto as Exhibit A and incorporated herein by reference;

NOW, THEREFORE, be it hereby resolved that:

1. The foregoing recitals are true and correct.
2. The Board hereby accepts the Notice of Completion for Project No. 19-0068-015. The Board delegates authority to the Superintendent and the Assistant Superintendent of Business Services or their designee to ensure that the Notice of Completion is filed with the Office of the Ventura County Recorder.

PASSED AND ADOPTED by the Board of Education at a regular meeting held on the 21st day of October, 2020 by the following vote on roll call:

AYES:

NOES:

ABSENT:

ABSTAIN:

Linda Armas, President of the Board of
Trustees

9.20



Agenda Item Details

Meeting	Oct 21, 2020 - RSD Regular Board Meeting
Category	9. Consent
Subject	9.20 Approval of Resolution 20/21-19 for the Notice of Completion for Roofing and Sheet Metal by Channel Islands Roofing at Rio Del Sol
Access	Public
Type	Action (Consent)
Recommended Action	It is recommended that the Board approve the resolution for the Notice of Completion by Channel Islands Roofing at Rio Del Sol.

Public Content

Speaker:
Wael Saleh, Assistant Superintendent, Business Services

Rationale:

It is requested that the Board approve the issuance of the Notice of Completion for work related to RSD Project 19-0068-015, at Rio Del Sol Steam for the Sheet Metal work by Channel Islands Roofing. The Project Manager has confirmed that all contract installation requirements have been satisfied by Channel Islands Roofing.

[Channel Islands Roofing NOC.pdf \(93 KB\)](#)

[Resolution 20-21-19 NOC CIR.pdf \(107 KB\)](#)

Administrative Content

Executive Content

Our adopted rules of Parliamentary Procedure, Robert's Rules, provide for a consent agenda listing several items for approval of the Board by a single motion. Most of the items listed under the consent agenda have gone through Board subcommittee review and recommendation. Documentation concerning these items has been provided to all Board members and the public in advance to assure an extensive and thorough review. Items may be removed from the consent agenda at the request of any board member.

Balfour Beatty Construction

Rio School District
1800 Solar Drive, 3rd Floor
Oxnard, CA 93030
Attn: Dr. Puglisi

October 2, 2020

Subject: Measure L Projects
Rio School District
Oxnard, CA

Re: Project #19-0068-015 Rio Del Sol, STEAM Academy, Building C
Recommendation to Request Board Approval for Issuance of Notice of Completion
Bid Package #6 Roofing and Sheet Metal

Dear Dr. Puglisi,

Please accept this letter as recommendation to request Board approval for issuance of the Notice of Completion for work related to RSD Project #19-0068-015 Rio Del Sol, STEAM Academy, Building C. All contract installation requirements have been satisfied by Channel Islands Roofing, Inc. for Bid Package #6 Roofing and Sheet Metal. The final contract amount is as follows;

Channel Islands Roofing, Inc. Base Agreement	\$ 299,097.00
Channel Islands Roofing, Inc. Total Change Order Amount	\$ (31,628.00)
FINAL Cost	\$ 267,469.00

Should you have any questions, please contact me at any time.

Respectfully,



Jesus Muguerza Ibarra
Assistant Project Manager, Balfour Beatty

cc. Wael Saleh, Rio School District
Dennis Kuykendall, Balfour Beatty

RIO SCHOOL DISTRICT

RESOLUTION NO. 20/21-19

**NOTICE OF COMPLETION OF BID PACKAGE #6 FOR
ROOFING AND SHEET METAL BY CHANNEL ISLANDS ROOFING
AT RIO DEL SOL**

WHEREAS, pursuant to RSD Project No. 19-0068-015, the Rio School District (“District”) contracted with Channel Islands Roofing for Roofing and Sheet Metal (Bid Package #6) at Rio Del Sol STEAM School; and

WHEREAS, Contractor subsequently commenced the work on Project No. 19-0068-015; and

WHEREAS, on October 2, 2020, the project construction manager confirmed that the work for Project has been closed and certified the job was complete in accordance with the plans and specifications; and

WHEREAS, District has now determined that a Notice of Completion can be filed, attached hereto as Exhibit A and incorporated herein by reference;

NOW, THEREFORE, be it hereby resolved that:

1. The foregoing recitals are true and correct.
2. The Board hereby accepts the Notice of Completion for Project No. 19-0068-015. The Board delegates authority to the Superintendent and the Assistant Superintendent of Business Services or their designee to ensure that the Notice of Completion is filed with the Office of the Ventura County Recorder.

PASSED AND ADOPTED by the Board of Education at a regular meeting held on the 21st day of October, 2020 by the following vote on roll call:

AYES:

NOES:

ABSENT:

ABSTAIN:

Linda Armas, President of the Board of Trustees

9.21



Agenda Item Details

Meeting	Oct 21, 2020 - RSD Regular Board Meeting
Category	9. Consent
Subject	9.21 Approval of Resolution 20/21-20 for the Notice of Completion of Floored Tile and Stone at Rio Del Sol
Access	Public
Type	Action (Consent)
Recommended Action	It is recommended that the Board approve the resolution for the Notice of Completion by Floored Tile and Stone at Rio Del Sol.

Public Content

Speaker:
Wael Saleh, Assistant Superintendent, Business Services

Rationale:

It is requested that the Board approve the issuance of the Notice of Completion for work related to RSD Project 19-0068-015, at Rio Del Sol Steam for the work completed by Floored Tile and Stone. The Project Manager has confirmed that all contract installation requirements have been satisfied by Floored Tile and Stone.

[Floored Tile and Stone NOC.pdf \(91 KB\)](#)

[Resolution 20-21-20 NOC FT&S.pdf \(103 KB\)](#)

Administrative Content

Executive Content

Our adopted rules of Parliamentary Procedure, Robert's Rules, provide for a consent agenda listing several items for approval of the Board by a single motion. Most of the items listed under the consent agenda have gone through Board subcommittee review and recommendation. Documentation concerning these items has been provided to all Board members and the public in advance to assure an extensive and thorough review. Items may be removed from the consent agenda at the request of any board member.

Balfour Beatty

Construction

Rio School District
1800 Solar Drive, 3rd Floor
Oxnard, CA 93030
Attn; Dr. Puglisi

October 2, 2020

Subject: Measure L Projects
Rio School District
Oxnard, CA

Re: Project #19-0068-015 Rio Del Sol, STEAM Academy, Building C
Recommendation to Request Board approval for issuance of Notice of Completion
Bid Package #10 Ceramic Tile

Dear Dr. Puglisi,

Please accept this letter as recommendation to request Board approval for issuance of the Notice of Completion for work related to RSD Project #19-0068-015 Rio Del Sol, STEAM Academy, Building C. All contract installation requirements have been satisfied by Floored Tile and Stone, Inc. for Bid Package #10 Ceramic Tile. The final contract amount is as follows;

Floored Tile and Stone, Inc. Base Agreement	\$	31,000.00
Floored Tile and Stone, Inc. Total Change Order Amount	\$	0.00
FINAL Cost	\$	31,000.00

Should you have any questions, please contact me at any time.

Respectfully,



Jesus Muguerza Ibarra
Assistant Project Manager, Balfour Beatty

cc. Wael Saleh, Rio School District
Dennis Kuykendall, Balfour Beatty

RIO SCHOOL DISTRICT
RESOLUTION NO. 20/21-20
NOTICE OF COMPLETION OF BID PACKAGE #10 FOR
CERAMIC TILE BY FLOORED TILE AND STONE, INC.
AT RIO DEL SOL

WHEREAS, pursuant to RSD Project No. 19-0068-015, the Rio School District (“District”) contracted with Channel Islands Roofing for Roofing and Sheet Metal (Bid Package #10) at Rio Del Sol STEAM School; and

WHEREAS, Contractor subsequently commenced the work on Project No. 19-0068-015; and

WHEREAS, on October 2, 2020, the project construction manager confirmed that the work for Project has been closed and certified the job was complete in accordance with the plans and specifications; and

WHEREAS, District has now determined that a Notice of Completion can be filed, attached hereto as Exhibit A and incorporated herein by reference;

NOW, THEREFORE, be it hereby resolved that:

1. The foregoing recitals are true and correct.
2. The Board hereby accepts the Notice of Completion for Project No. 19-0068-015. The Board delegates authority to the Superintendent and the Assistant Superintendent of Business Services or their designee to ensure that the Notice of Completion is filed with the Office of the Ventura County Recorder.

PASSED AND ADOPTED by the Board of Education at a regular meeting held on the 21st day of October, 2020 by the following vote on roll call:

AYES:

NOES:

ABSENT:

ABSTAIN:

Linda Armas, President of the Board of Trustees

9.22



Agenda Item Details

Meeting	Oct 21, 2020 - RSD Regular Board Meeting
Category	9. Consent
Subject	9.22 Approval of Resolution 20/21-21 for the Notice of Completion of the Automatic Fire Sprinkler by JPI Development Group, Inc. at Rio Del Sol
Access	Public
Type	Action (Consent)
Recommended Action	It is recommended that the Board approve the resolution for the Notice of Completion by JPI Development Group, Inc. at Rio Del Sol.

Public Content

Speaker:
Wael Saleh, Assistant Superintendent, Business Services

Rationale:

It is requested that the Board approve the issuance of the Notice of Completion for work related to RSD Project 19-0068-015, at Rio Del Sol Steam for the Automatic Sprinkler System by JPI Development Group, Inc. The Project Manager has confirmed that all contract installation requirements have been satisfied by JPI Development Group, Inc.

[Resolution 20-21-21 NOC JPI.pdf \(105 KB\)](#)

[Resolution 20-21-21 NOC JPI.pdf \(105 KB\)](#)

Administrative Content

Executive Content

Our adopted rules of Parliamentary Procedure, Robert's Rules, provide for a consent agenda listing several items for approval of the Board by a single motion. Most of the items listed under the consent agenda have gone through Board subcommittee review and recommendation. Documentation concerning these items has been provided to all Board members and the public in advance to assure an extensive and thorough review. Items may be removed from the consent agenda at the request of any board member.

RIO SCHOOL DISTRICT
RESOLUTION NO. 20/21-21
NOTICE OF COMPLETION OF BID PACKAGE #12 FOR
AUTOMATIC FIRE SPRINKLER SYSTEM BY JPI DEVELOPMENT GROUP, INC.
AT RIO DEL SOL

WHEREAS, pursuant to RSD Project No. 19-0068-015, the Rio School District (“District”) contracted with Automatic Fire Sprinkler System by JPI Development Group, Inc. (Bid Package #12) at Rio Del Sol STEAM School; and

WHEREAS, Contractor subsequently commenced the work on Project No. 19-0068-015; and

WHEREAS, on October 2, 2020, the project construction manager confirmed that the work for Project has been closed and certified the job was complete in accordance with the plans and specifications; and

WHEREAS, District has now determined that a Notice of Completion can be filed, attached hereto as Exhibit A and incorporated herein by reference;

NOW, THEREFORE, be it hereby resolved that:

1. The foregoing recitals are true and correct.
2. The Board hereby accepts the Notice of Completion for Project No. 19-0068-015. The Board delegates authority to the Superintendent and the Assistant Superintendent of Business Services or their designee to ensure that the Notice of Completion is filed with the Office of the Ventura County Recorder.

PASSED AND ADOPTED by the Board of Education at a regular meeting held on the 21st day of October, 2020 by the following vote on roll call:

AYES:

NOES:

ABSENT:

ABSTAIN:

Linda Armas, President of the Board of
Trustees

RIO SCHOOL DISTRICT
RESOLUTION NO. 20/21-21
NOTICE OF COMPLETION OF BID PACAKAGE #12 FOR
AUTOMATIC FIRE SPRINKLER SYSTEM BY JPI DEVELOPMENT GROUP, INC.
AT RIO DEL SOL

WHEREAS, pursuant to RSD Project No. 19-0068-015, the Rio School District (“District”) contracted with Automatic Fire Sprinkler System by JPI Development Group, Inc. (Bid Package #12) at Rio Del Sol STEAM School; and

WHEREAS, Contractor subsequently commenced the work on Project No. 19-0068-015; and

WHEREAS, on October 2, 2020, the project construction manager confirmed that the work for Project has been closed and certified the job was complete in accordance with the plans and specifications; and

WHEREAS, District has now determined that a Notice of Completion can be filed, attached hereto as Exhibit A and incorporated herein by reference;

NOW, THEREFORE, be it hereby resolved that:

1. The foregoing recitals are true and correct.
2. The Board hereby accepts the Notice of Completion for Project No. 19-0068-015. The Board delegates authority to the Superintendent and the Assistant Superintendent of Business Services or their designee to ensure that the Notice of Completion is filed with the Office of the Ventura County Recorder.

PASSED AND ADOPTED by the Board of Education at a regular meeting held on the 21st day of October, 2020 by the following vote on roll call:

AYES:

NOES:

ABSENT:

ABSTAIN:

Linda Armas, President of the Board of
Trustees

9.23



Agenda Item Details

Meeting	Oct 21, 2020 - RSD Regular Board Meeting
Category	9. Consent
Subject	9.23 Approval of Resolution 20/21-22 for the Notice of Completion of Irrigation, Landscape Planting by Pierre Landscape, Inc. at Rio Del Sol
Access	Public
Type	Action (Consent)
Recommended Action	It is recommended that the Board approve the resolution for the Notice of Completion by Pierre Landscape, Inc. at Rio Del Sol.

Public Content

Speaker:
Wael Saleh, Assistant Superintendent, Business Services

Rationale:

It is requested that the Board approve the issuance of the Notice of Completion for work related to RSD Project 19-0068-015, at Rio Del Sol Steam for the Landscape Planning and Irrigation by Pierre Landscape. The Project Manager has confirmed that all contract installation requirements have been satisfied by Pierre Landscape, Inc.

Rio STEAM Bldg C - PL - Recommendation NOC - 10-2-20.pdf (91 KB)

Resolution 20-21-22 NOC PL.pdf (105 KB)

Administrative Content

Executive Content

Our adopted rules of Parliamentary Procedure, Robert's Rules, provide for a consent agenda listing several items for approval of the Board by a single motion. Most of the items listed under the consent agenda have gone through Board subcommittee review and recommendation. Documentation concerning these items has been provided to all Board members and the public in advance to assure an extensive and thorough review. Items may be removed from the consent agenda at the request of any board member.

Balfour Beatty Construction

Rio School District
1800 Solar Drive, 3rd Floor
Oxnard, CA 93030
Attn; Dr. Puglisi

October 2, 2020

Subject: Measure L Projects
Rio School District
Oxnard, CA

Re: Project #19-0068-015 Rio Del Sol, STEAM Academy, Building C
Recommendation to Request Board approval for issuance of Notice of Completion
Bid Package #15 Irrigation, Landscape Planting

Dear Dr. Puglisi,

Please accept this letter as recommendation to request Board approval for issuance of the Notice of Completion for work related to RSD Project #19-0068-015 Rio Del Sol, STEAM Academy, Building C. All contract installation requirements have been satisfied by Pierre, Landscape, Inc. for Bid Package #15 Irrigation, Landscape Planting. The final contract amount is as follows;

Pierre, Landscape, Inc. Base Agreement	\$ 296,121.00
Pierre, Landscape, Inc. Total Change Order Amount	\$ (38,123.00)
FINAL Cost	\$ 257,998.00

Should you have any questions, please contact me at any time.

Respectfully,



Jesus Muguerza Ibarra
Assistant Project Manager, Balfour Beatty

cc. Wael Saleh, Rio School District
Dennis Kuykendall, Balfour Beatty

RIO SCHOOL DISTRICT
RESOLUTION NO. 20/21-22
NOTICE OF COMPLETION OF BID PACKAGE #15 FOR
IRRIGATION AND LANDSCAPE PLANTING
BY PIERRE LANDSCAPE, INC. AT RIO DEL SOL

WHEREAS, pursuant to RSD Project No. 19-0068-015, the Rio School District (“District”) contracted with Pierre Landscape, Inc. (Bid Package #15) for irrigation and landscaping planning at Rio Del Sol STEAM School; and

WHEREAS, Contractor subsequently commenced the work on Project No. 19-0068-015; and

WHEREAS, on October 2, 2020, the project construction manager confirmed that the work for Project has been closed and certified the job was complete in accordance with the plans and specifications; and

WHEREAS, District has now determined that a Notice of Completion can be filed, attached hereto as Exhibit A and incorporated herein by reference;

NOW, THEREFORE, be it hereby resolved that:

1. The foregoing recitals are true and correct.
2. The Board hereby accepts the Notice of Completion for Project No. 19-0068-015. The Board delegates authority to the Superintendent and the Assistant Superintendent of Business Services or their designee to ensure that the Notice of Completion is filed with the Office of the Ventura County Recorder.

PASSED AND ADOPTED by the Board of Education at a regular meeting held on the 21st day of October, 2020 by the following vote on roll call:

AYES:

NOES:

ABSENT:

ABSTAIN:

Linda Armas, President of the Board of Trustees

9.24



Agenda Item Details

Meeting	Oct 21, 2020 - RSD Regular Board Meeting
Category	9. Consent
Subject	9.24 Approval of Resolution 20/21-23 for the Notice of Completion for flooring by KYA Services LLC at Rio Del Sol
Access	Public
Type	Action (Consent)
Recommended Action	It is recommended that the Board approve the resolution for the Notice of Completion by KYA Services LLC at Rio Del Sol.

Public Content

Speaker:
Wael Saleh, Assistant Superintendent, Business Services

Rationale:

It is requested that the Board approve the issuance of the Notice of Completion for work related to RSD Project 19-0068-015, at Rio Del Sol Steam for the flooring by KYA Services LLC at Rio Del Sol. The Project Manager has confirmed that all contract installation requirements have been satisfied by KYA services LLC.

[KYA Flooring NOC RDS.pdf \(90 KB\)](#)

[Resolution 20-21-23 NOC KYA.pdf \(108 KB\)](#)

Administrative Content

Executive Content

Our adopted rules of Parliamentary Procedure, Robert's Rules, provide for a consent agenda listing several items for approval of the Board by a single motion. Most of the items listed under the consent agenda have gone through Board subcommittee review and recommendation. Documentation concerning these items has been provided to all Board members and the public in advance to assure an extensive and thorough review. Items may be removed from the consent agenda at the request of any board member.

Balfour Beatty

Construction

Rio School District
1800 Solar Drive, 3rd Floor
Oxnard, CA 93030
Attn; Dr. Puglisi

October 2, 2020

Subject: Measure L Projects
Rio School District
Oxnard, CA

Re: Project #19-0068-015 Rio Del Sol, STEAM Academy, Building C
Recommendation to Request Board approval for issuance of Notice of Completion
Bid Package #16 Flooring

Dear Dr. Puglisi,

Please accept this letter as recommendation to request Board approval for issuance of the Notice of Completion for work related to RSD Project #19-0068-015 Rio Del Sol, STEAM Academy, Building C. All contract installation requirements have been satisfied by KYA Services LLC for Bid Package #16 Flooring. The final contract amount is as follows;

KYA Services LLC Base Agreement	\$	235,000.00
KYA Services LLC Total Change Order Amount	\$	(2,000.00)
FINAL Cost	\$	233,000.00

Should you have any questions, please contact me at any time.

Respectfully,



Jesus Muguerza Ibarra
Assistant Project Manager, Balfour Beatty

cc. Wael Saleh, Rio School District
Dennis Kuykendall, Balfour Beatty

RIO SCHOOL DISTRICT

RESOLUTION NO. 20/21-23

**NOTICE OF COMPLETION OF BID PACKAGE #16 FOR
FLOORING BY KYA SERVICES LLC AT RIO DEL SOL**

WHEREAS, pursuant to RSD Project No. 19-0068-015, the Rio School District (“District”) contracted with KYA Services LLC, (Bid Package #16) for irrigation and landscaping planning at Rio Del Sol STEAM School; and

WHEREAS, Contractor subsequently commenced the work on Project No. 19-0068-015; and

WHEREAS, on October 2, 2020, the project construction manager confirmed that the work for Project has been closed and certified the job was complete in accordance with the plans and specifications; and

WHEREAS, District has now determined that a Notice of Completion can be filed, attached hereto as Exhibit A and incorporated herein by reference;

NOW, THEREFORE, be it hereby resolved that:

1. The foregoing recitals are true and correct.
2. The Board hereby accepts the Notice of Completion for Project No. 19-0068-015. The Board delegates authority to the Superintendent and the Assistant Superintendent of Business Services or their designee to ensure that the Notice of Completion is filed with the Office of the Ventura County Recorder.

PASSED AND ADOPTED by the Board of Education at a regular meeting held on the 21st day of October, 2020 by the following vote on roll call:

AYES:

NOES:

ABSENT:

ABSTAIN:

Linda Armas, President of the Board of Trustees

9.25



Agenda Item Details

Meeting	Oct 21, 2020 - RSD Regular Board Meeting
Category	9. Consent
Subject	9.25 Notice of Completion and Resolution 20/21-25 for the Accoustical Treatment at RDV Gym by Tech-Wall
Access	Public
Type	Action (Consent)
Recommended Action	It is recommended that the Resolution for the Notice of Completion for work by Tech-wall be approved.

Public Content

Speaker:
Wael Saleh, Assistant Superintendent, Business Services

Rationale:

It is requested that the Board approve the issuance of the Notice of Completion for work related to RSD Project 20-20L, at Rio Del Valle Middle School for the accoustical treatment in the gym by Tech-Wall. The Project Manager has confirmed that all contract installation requirements have been satisfied by Tech-wall and the project can now be closed.

20-20L Techwall Notice of Completion Reccommendation Copy for October Board Meeting 9 30 2020.pdf (22 KB)

Resolution 20-21-25 NOC Techwall .pdf (99 KB)

Administrative Content

Executive Content

Our adopted rules of Parliamentary Procedure, Robert's Rules, provide for a consent agenda listing several items for approval of the Board by a single motion. Most of the items listed under the consent agenda have gone through Board subcommittee review and recommendation. Documentation concerning these items has been provided to all Board members and the public in advance to assure an extensive and thorough review. Items may be removed from the consent agenda at the request of any board member.

Balfour Beatty Construction

Rio School District
1800 Solar, 3rd Floor
Oxnard, CA 93030
Attn: Dr. Puglisi

September 30, 2020

Subject: Measure L Projects
Rio School District
Oxnard, CA

Re: Project #20-20L Acoustical Treatment in Gym at Rio Del Valle Middle School.
Recommendation to Request Board approval for issuance of Notice of Completion
For Tech-Wall.

Dear Dr. Puglisi,

Please accept this letter as recommendation to request Board approval for issuance of the Notice of Completion for work related to RSD Project #20-20L Acoustical Treatment in Gym at Rio Del Valle Middle School. All contract installation requirements have been satisfied by Tech-Wall for Bid #20-20L. The final contract amount is as follows;

Tech-Wall	Base Agreement	\$ 79,674.00
Tech-Wall	Total Change Order Amount	\$ 0
FINAL Cost		\$ 79,674.00

Should you have any questions, please contact me at any time.

Respectfully,



Keith Henderson
Senior Project Manager, Balfour Beatty

cc. Wael Saleh, Rio School District
Jesus Muguerza Ibarra, Balfour Beatty

RIO SCHOOL DISTRICT
RESOLUTION NO. 20/21-25
NOTICE OF COMPLETION OF PROJECT 20-20L FOR
THE ACCOUSTICAL TREATMENT IN GYM AT RDV BY TECH-WALL

WHEREAS, pursuant to RSD Project No. 20-20L, the Rio School District (“District”) contracted with Tech-Wall for the accoustical treatment of the gym at Rio Del Valle Middle School; and

WHEREAS, Contractor subsequently commenced the work on Project No. 20-20L; and

WHEREAS, on October 6, 2020, the project construction manager confirmed that the work for Project has been closed and certified the job was complete in accordance with the plans and specifications; and

WHEREAS, District has now determined that a Notice of Completion can be filed, attached hereto as Exhibit A and incorporated herein by reference;

NOW, THEREFORE, be it hereby resolved that:

1. The foregoing recitals are true and correct.
2. The Board hereby accepts the Notice of Completion for Project No. 20-20L. The Board delegates authority to the Superintendent and the Assistant Superintendent of Business Services or their designee to ensure that the Notice of Completion is filed with the Office of the Ventura County Recorder.

PASSED AND ADOPTED by the Board of Education at a regular meeting held on the 21st day of October, 2020 by the following vote on roll call:

AYES:

NOES:

ABSENT:

ABSTAIN:

Linda Armas, President of the Board of
Trustees

9.26



Agenda Item Details

Meeting	Oct 21, 2020 - RSD Regular Board Meeting
Category	9. Consent
Subject	9.26 Approval of the Resolution for the Notice of Completion from Pacificom for the new audio system in the RDV gym.
Access	Public
Type	Action (Consent), Presentation
Recommended Action	Approval of the Resolution for the Notice of Completion from Pacificom for the new audio system in the RDV gym.

Public Content

Speaker:
Wael Saleh, Assistant Superintendent, Business Services

Rationale:

It is requested that the Board approve the issuance of the Notice of Completion for work related to RSD Project 20-21L, at Rio Del Valle gym for the new audio system at Rio Del Valle Middle School. The Project Manager has confirmed that all contract installation requirements have been satisfied by Pacificom and the project can now be closed.

20-21L Pacificom Notice of Completion Recommendation for October 2020 Board Meeting 9 30 2020.pdf (22 KB)

Resolution 20-21-26 NOC Pacificom.pdf (99 KB)

Administrative Content

Executive Content

Our adopted rules of Parliamentary Procedure, Robert's Rules, provide for a consent agenda listing several items for approval of the Board by a single motion. Most of the items listed under the consent agenda have gone through Board subcommittee review and recommendation. Documentation concerning these items has been provided to all Board

members and the public in advance to assure an extensive and thorough review. Items may be removed from the consent agenda at the request of any board member.

Balfour Beatty Construction

Rio School District
1800 Solar, 3rd Floor
Oxnard, CA 93030
Attn: Dr. Puglisi

September 30, 2020

Subject: Measure L Projects
Rio School District
Oxnard, CA

Re: Project #20-21L New Audio System in Gym at Rio Del Valle Middle School.
Recommendation to Request Board approval for issuance of Notice of Completion
For Pacificom.

Dear Dr. Puglisi,

Please accept this letter as recommendation to request Board approval for issuance of the Notice of Completion for work related to RSD Project #20-21L New Audio System in Gym at Rio Del Valle Middle School. All contract installation requirements have been satisfied by Pacificom for Bid #20-21L. The final contract amount is as follows;

Pacificom	Base Agreement	\$ 44,900.00
Pacificom	Total Change Order Amount	\$ 0
FINAL Cost		\$ 44,900.00

Should you have any questions, please contact me at any time.

Respectfully,



Keith Henderson
Senior Project Manager, Balfour Beatty

cc. Wael Saleh, Rio School District
Jesus Muguerza Ibarra, Balfour Beatty

RIO SCHOOL DISTRICT
RESOLUTION NO. 20/21-26
NOTICE OF COMPLETION OF PROJECT 20-21L FOR
THE NEW AUDIO SYSTEM IN GYM AT RDV BY PACIFICOM

WHEREAS, pursuant to RSD Project No. 20-20L, the Rio School District (“District”) contracted with Pacificom for the new audio system in the gym at Rio Del Valle Middle School; and

WHEREAS, Contractor subsequently commenced the work on Project No. 20-21L; and

WHEREAS, on October 6, 2020, the project construction manager confirmed that the work for Project has been closed and certified the job was complete in accordance with the plans and specifications; and

WHEREAS, District has now determined that a Notice of Completion can be filed, attached hereto as Exhibit A and incorporated herein by reference;

NOW, THEREFORE, be it hereby resolved that:

1. The foregoing recitals are true and correct.
2. The Board hereby accepts the Notice of Completion for Project No. 20-21L. The Board delegates authority to the Superintendent and the Assistant Superintendent of Business Services or their designee to ensure that the Notice of Completion is filed with the Office of the Ventura County Recorder.

PASSED AND ADOPTED by the Board of Education at a regular meeting held on the 21st day of October, 2020 by the following vote on roll call:

AYES:

NOES:

ABSENT:

ABSTAIN:

Linda Armas, President of the Board of Trustees

9.27



Agenda Item Details

Meeting	Oct 21, 2020 - RSD Regular Board Meeting
Category	9. Consent
Subject	9.27 Approval of Resolution for the Notice of Completion for the bathroom repairs at Rio Rosales by Kiwitt's General Building Contractor at Rio Rosales.
Access	Public
Type	Action (Consent)
Recommended Action	It is recommended that the Board Approve Resolution for the Notice of Completion for the bathroom repairs at Rio Rosales by Kiwitt's General Building Contractor at Rio Rosales.

Public Content

Speaker:
Wael Saleh, Assistant Superintendent, Business Services

Rationale:

It is requested that the Board approve the issuance of the Notice of Completion for work related to RSD Project 20-25L, at Rio Rosales for the work completed by Kiwitt's General Building Contractor for bathroom repairs. The Project Manager has confirmed that all contract installation requirements have been satisfied by Kiwitt's General Building Contractor and the project can now be closed.

[Resolution 20-21-28 NOC Kiwitsts .pdf \(103 KB\)](#)

[20-25L REV1 Kiwitt's Recommendation Letter for Notice of Completion 10 13 2020 \(1\).pdf \(26 KB\)](#)

Administrative Content

Executive Content

Our adopted rules of Parliamentary Procedure, Robert's Rules, provide for a consent agenda listing several items for approval of the Board by a single motion. Most of the items listed under the consent agenda have gone through Board subcommittee review and recommendation. Documentation concerning these items has been provided to all Board members and the public in advance to assure an extensive and thorough review. Items may be removed from the consent agenda at the request of any board member.

RIO SCHOOL DISTRICT

RESOLUTION NO. 20/21-28

NOTICE OF COMPLETION OF PROJECT 20-25L FOR

THE BATHROOM REPAIRS AT RIO ROSALES BY KIWITTS GENERAL BUILDING CONTRACTOR

WHEREAS, pursuant to RSD Project No. 20-25L, the Rio School District (“District”) contracted with Kiwitts General Building Contractor, Inc. for the bathroom repairs at Rio Rosales; and

WHEREAS, Contractor subsequently commenced the work on Project No. 20-25L; and

WHEREAS, on October 6, 2020, the project construction manager confirmed that the work for Project has been closed and certified the job was complete in accordance with the plans and specifications; and

WHEREAS, District has now determined that a Notice of Completion can be filed, attached hereto as Exhibit A and incorporated herein by reference;

NOW, THEREFORE, be it hereby resolved that:

1. The foregoing recitals are true and correct.
2. The Board hereby accepts the Notice of Completion for Project No. 20-25L. The Board delegates authority to the Superintendent and the Assistant Superintendent of Business Services or their designee to ensure that the Notice of Completion is filed with the Office of the Ventura County Recorder.

PASSED AND ADOPTED by the Board of Education at a regular meeting held on the 21st day of October, 2020 by the following vote on roll call:

AYES:

NOES:

ABSENT:

ABSTAIN:

Linda Armas, President of the Board of Trustees

Balfour Beatty Construction

Rio School District
1800 Solar, 3rd Floor
Oxnard, CA 93030
Attn; Dr. Puglisi

October 13, 2020 (REV1)

Subject: Measure L Projects
Rio School District
Oxnard, CA

Re: Project #20-25L COVID 19 Bathroom Repairs at Rio Rosales Elementary School.
Recommendation to Request Board approval for issuance of Notice of Completion
For Kiwitt's General Building.

Dear Dr. Puglisi,

Please accept this letter as recommendation to request Board Approval for issuance of the Notice of Completion for work related to RSD Project #20-25L COVID 19 Bathroom Repairs at Rio Rosales Elementary School. All contract installation requirements have been satisfied by Kiwitt's General Building for Bid #20-25L.

The final contract amount is as follows;

Kiwitt's General Building	Base Agreement	\$ 89,000.00
Kiwitt's General Building	Total Change Order Amount	\$ 5,850.00
FINAL Cost		\$ 94,850.00

Should you have any questions, please contact me at any time.

Respectfully,



Keith Henderson
Senior Project Manager, Balfour Beatty

cc. Wael Saleh, Rio School District
Jesus Muguerra Ibarra, Balfour Beatty

9.28



Agenda Item Details

Meeting	Oct 21, 2020 - RSD Regular Board Meeting
Category	9. Consent
Subject	9.28 Approval of Recommendation for a Generator to be installed for RSD and OUHSD
Access	Public
Type	Action (Consent)
Fiscal Impact	Yes
Dollar Amount	179,836.14
Budgeted	Yes
Budget Source	Developer Fees
Recommended Action	It is recommended that the installation of a generator at Rio School District Office be approved.

Public Content

Speaker:

Wael Saleh, Assistant Superintendent, Business Services

Rationale:

The Oxnard Union High School District and the Rio School District jointly participating in and installing a New Standby Generator/Uninterrupted Power Source (UPS) to provide Standby Power during High Wind and Other Emergency Type Events.

Local power outages are becoming more frequent since California utility companies have begun shutting down power during high wind events, during fire season and heat waves. Both Rio SD and Oxnard Union HSD desire a generator to be provided at 1800 Solar Drive to provide backup power for the voice, data and other low voltage systems, some power outlets and lighting, and air flow in the event of a local power outage.

The Estimated Budget Cost for the Standby Generator project is as follows:

- 1) Lucci & Associates Engineering Services: \$32,900.00 (Proposal Attached) (Use \$33K Credit from Old Generator sale)
 - 2) Quinn Caterpillar Generator Cost: \$316,553.79 (Proposal Attached) (8% Tax Added)
 - 3) Budget Cost for Diesel Exhaust Scrubber System **if Required** by Ventura County Air Pollution Control District. (VCAPCD) :\$135,000.00
 - 4) Construction Budget for Generator Installation: \$100,000.00
 - 5) Permits & Fees Budget: \$15,000.00
- Total Estimated Cost \$599,453.79

(Note: Cost Item # 3 may not be required, Cost Items 4 & 5 are Budget Costs)

Breakdown of 70/30% Construction Cost Per Tenant

A) Oxnard Union High School District: \$419,617.65

B) Rio School District: \$179,836.14 (Use Developer Fees)

Rio REV 1 DO Generator Recommendation for Approval at October 2020 Board Mtg .pdf (608 KB)

Administrative Content

Executive Content

Our adopted rules of Parliamentary Procedure, Robert's Rules, provide for a consent agenda listing several items for approval of the Board by a single motion. Most of the items listed under the consent agenda have gone through Board subcommittee review and recommendation. Documentation concerning these items has been provided to all Board members and the public in advance to assure an extensive and thorough review. Items may be removed from the consent agenda at the request of any board member.

Balfour Beatty Construction

Rio School District
1800 Solar, 3rd Floor
Oxnard, CA 93030
Attn: Dr. Puglisi

October 12, 2019 (REV1)

Subject: Recommendation for Standby Generator/Uninterrupted Power Source (UPS) at 1800 Solar, Oxnard Ca.

Re: Request by Oxnard Union High School District for Approval of Installation and Sharing of Standby Power Usage and Costs with the Rio School District as Joint Tenant

Dear Dr. Puglisi,

The Oxnard Union High School District as Joint Tenants with the Rio School District would like to install a New Standby Generator/Uninterrupted Power Source (UPS) to provide Standby Power during High Wind and Other Emergency Type Events.

Local power outages are becoming more frequent since California utility companies have begun shutting down power during high wind events. Both Rio SD and Oxnard Union HSD desire a generator to be provided at 1800 Solar Drive to provide backup power for the voice, data and other low voltage systems, some power outlets and lighting, and air flow in the event of a local power outage.

As you may well know, the new District Office at 1800 Solar previously had a 1750 KW Standby Generator System in place at the time of purchase. The existing Standby Diesel Generator had been decommissioned as a part of the sale of the building to Rio School District and Oxnard Union High School District due to its age and inability to be "code" compliant with new State and County Air Pollution Control District Requirements. Rio School District and Oxnard Union High School District Sold the old Standby Generator. The Funds obtained from the Sale (\$40,000.00 minus \$7K to remove) is planned to be used toward any fees for Engineering Services for a new design to install a new smaller replacement standby generator that complies with regulatory requirements to meet both Building Tenants Power needs in an emergency.

The Rio School District in Association with Oxnard Union High School District has now reached out to Lucci & Associates to provide Electrical Engineering services to get regulatory agency approval for the generator installation and for contractor support during construction.

Lucci & Associates has submitted a proposal for Engineering Services and at the request of both Districts, provided a recommendation to purchase a 1000 KW 3 phase 277/480 volt Generator proposed by Quinn power systems on September 16, 2020 as the appropriate size to service 1800 Solar Drive as described above.

Quinn Power Systems has provided proposal (AWA13351) which includes Sourcewell (formally National Joint Powers Alliance) Special Pricing for a total of \$293,086.84 plus tax for the Caterpillar C32 1000 KW Diesel Generator. Oxnard Union is proposing to use their HSD Sourcewell member identification number noted as 6337 for generator purchase contract number identified as 120617-CAT. **Unless otherwise indicated, costs associated with the emergency generator installation will be split 70/30 between Oxnard Union HSD and Rio SD respectively. Funding will be by Oxnard Union HSD to pay for the generator purchase with subsequent reimbursement by Rio SD.**

Oxnard Union High School District after obtaining approval from the Rio School District as Joint Tenants at 1800 Solar, Oxnard Ca. would like to move forward with procuring and installing the new Standby Generator UPS System sharing all costs to complete this task as a 70/30 Cost Split.

Rio School District has assembled what it believes to be are the costs to complete the work to install the New Standby Generator UPS System. This information follows and has been provided for review and approval.

The Estimated Budget Cost for the Standby Generator project is as follows:

- 1) Lucci & Associates Engineering Services: \$32,900.00 (Proposal Attached) (Use \$33K Credit from Old Generator sale)
- 2) Quinn Caterpillar Generator Cost: \$316,553.79 (Proposal Attached) (8% Tax Added)
- 3) Budget Cost for Diesel Exhaust Scrubber System *if Required by Ventura County Air Pollution Control District. (VCAPCD)* :\$135,000.00
- 4) Construction Budget for Generator Installation: \$100,000.00
- 5) Permits & Fees Budget: \$15,000.00

FINAL Construction Budget/Cost **\$ 599,453.79**

(Note: Cost Item # 3 may not be required, Cost Items 4 & 5 are Budget Costs)

Breakdown of 70/30% Construction Cost Per Tenant

- A) Oxnard Union High School District: \$419,617.65
- B) Rio School District: \$179,836.14 (Use Developer Fees)

On behalf of Balfour Beatty Construction and as the District Representative for Measure L & G Bond Program, I/We recommend to the Rio School District's Board of Education and Superintendent of the Rio School District that this project be approved.

We feel that this project is critical for both of the Tenants to have standby power to be prepared to serve their communities in times of an emergency of any kind including wind outages, earthquakes, fires and now a Pandemic type situation.

Should you have any questions, please contact me at any time.

Respectfully,



Keith Henderson
Senior Project Manager, Balfour Beatty

- cc. Wael Saleh, Rio School District
dd. Jesus Mugerza Ibarra, Balfour Beatty
Dennis Kuykendall, Balfour Beatty

Date: October 1, 2020

To: Rio School District
1800 Solar, 3rd Floor
Oxnard, Ca 93030
Attn: Wael Saleh

From: Kenneth Lucci, P.E.

Project: Electrical Engineering Services for Replacement Genset at 1800 Solar Drive, Oxnard CA

Per your request, please find the enclosed proposal for electrical engineering services for your shared facility between El Rio School District and Oxnard Union High School District.

It is our understanding the project consists of evaluating the facility's existing electrical infra-structure to assist in sizing a replacement stand-by generator which would support the needs of both School Districts. We understand the intent of this project is to size the genset large enough to allow each School District to operate during a loss of power condition by SCE.

Project Electrical Design Scope of Services:

- Evaluate existing site conditions for SCE power, existing genset and Automatic Transfer Switch (ATS) plus the associated distribution equipment. Previous design considerations for a genset included the possible installation of a 275 KW Natural Gas powered genset which would only power the MDF/IDF equipment for each District Office.
- Site visits will be required in conjunction with review of existing electrical plans for the project main building.
- Emergency power for Emergency Lighting systems are presently provided by Inverter battery systems.
- Coordinate with the School District for any additional facility requirements related to the genset or loss of power conditions.

- Provide recommendations on improvement of the electrical power system reliability and performance.
- Coordinate with Schneider Controls with respect to recommendations on mechanical system controls and overall performance enhancements/energy savings.
- Provide Construction Documents for the genset electrical system.
- Provide book specifications to CSI format for Electrical Construction
- Drawings shall be prepared and ready for submission to plan check and coordinated with governing authorities.
- Construction administration to include review of submittal documents.
- Response to contractor RFIs is included in the project scope of services.
- Design to be provide on AutoCAD and not Revit.

Exclusions

- No architectural design or structural design is included
- No acoustical study is included
- No Arc Flash Study or Coordination Study is included

Electrical

Site Survey/Criteria Development-----	\$ 8,400.
Construction Documents-----	\$17,700.
CA/CM -----	\$4,800.
Total Electrical Engineering Fee --	\$30,900.

Structural Fee (estimated) ----- \$ 2,000.

Fee Schedule

<u>Classification</u>	<u>Hourly Rate</u>
Principal.....	\$205.00
Project Manager.....	\$195.00
Project Engineer.....	\$165.00
Design Engineer.....	\$145.00
Drafter.....	\$115.00
Word/Data Processing.....	\$85.00



QUOTATION

AWA13351

3500 Shepherd Street, City of Industry, California 90601
Box 227044, Los Angeles, California 90022-0744

PAGE 1 of 6

DATE: 10-07-20 ✓
Quotation Expires: 12-08-20

REV 1

To: Oxnard Union High School District
309 South K Street
Oxnard, CA 93030

Attn. Denne Rantz, Paul Hanson, Joshua Koenig, David Todd & Keith Henderson
Phone: 805-385-2519

Project Name: Caterpillar C32 1000 Kw Diesel Generator Set
Special pricing under Sourcewell formally (NJPA) program
NJPA Member I.D. Number for Oxnard Union High School District 6337
Caterpillar Inc. Energy / Generators Contact number 120617-CAT

Projects

Emissions: Tier 2 (Subject to A.P.C.D. approval)

(1) New Caterpillar Model C32 Stationary Mounted Diesel Standby Generator Set
EPA Certified Tier 2 / UL2200 Listed & IBC Certified Generator Set
Rated 1000 kW Stand-by with fan, 60 Hz, 3 phase, 277/480 at 1800 RPM.
Generator includes standard equipment and accessories listed in the
Attached bill of material.

Pricing Caterpillar List: \$406,279.29 Plus Tax
..... Non Caterpillar Items: \$24,942.52 Plus Tax
..... Total: \$431,221.81 Plus Tax

Sourcewell Formally (N.J.P.A.) Special Pricing Total: \$293,086.84 Plus Tax

NOTE: *Delivery (Estimated 14 to 17 weeks)
Please call for current lead times



3500 Shepherd Street, City of Industry, California 90801
Box 227044, Los Angeles, California 90022-0744

QUOTATION

AWA13351

PAGE 2 of 6

DATE: 10-07-20 ✓
Quotation Expires: 12-08-20

REV I

Bill of Material Generator Set

Generator and Attachments

Permanent magnet excitation
Generator upsize 1423/2B-2/3P-FW-PM frame
Space heater

Engine Control System

Electronic governor

Control Panel and Instrumentation

EMCP 4.4 Auto-start control panel (upgraded to NFPA 110)
Panel mounted voltage adjust potentiometer
Panel mounted audible alarm with mute
Contacts for common fault alarm signal
Contacts for generator set run signal
Speed adjustment
Panel light
Dust proof control
Local annunciator NFPA99-110
Remote annunciator panel (Shipped loose installed by others)
Generator running & Fault relay

Protection System

C32:
(Qty.1) 1600 amp, 3-pole, U.L. listed, main line circuit breaker
Auxiliary contact
SUSE decals and film

Exhaust System

Critical grade silencer system internally incorporated with enclosure

Fuel System

Sub Base Fuel Tank (2,000 gallon) Double Wall
UL Listed for United States (UL 142) NFPA 30 code, NFPA 37 and 110 standard
5 gallon spill containment
Wide base
Air cleaner
(Vent pipes & external alarm panel not included in sale quotation if required)



QUOTATION

AWA13351

3500 Shepherd Street, City of Industry, California 90601
Box 227044, Los Angeles, California 90022-0744

PAGE 3 of 6

DATE: 10-07-20 ✓
Quotation Expires: 12-08-20

REV 1

Mounting and Enclosures

Vibration isolators, installed between generator set and base rails
Weather & Sound protective, enclosure (White & Black)
Fixed louvers
External stop button
Panel view window
IBC certification wind enclosure
Load center

Starting System

Batteries heavy duty (Oversize)
Starter

Charging System

120 vac - UL listed, 10 amp, battery charger
Charging alternator
Battery disconnect switch

Cooling System

Jacket water heater
Low coolant temp alarm
Low coolant level shutdown
Initial fill of coolant

Lube System

Initial fill of lube oil

Documentation

UL 2200 listed package generator set
IBC Certified
Operation and maintenance manual
Factory test reports
Shop prep
Standard Warranty
Delivery to jobsite (Drop Shipped From Factory)
Standard crane offload included in sale quotation
Start-up (Field test) (standard field test) (Load bank test not included in quotation)
Fire Marshal testing not included in sale quotation if required

PLEASE NOTE: No written specification's provided for quotation



3500 Shepherd Street, City of Industry, California 90601
Box 227044, Los Angeles, California 90022-0744

QUOTATION

AWA13351

PAGE 4 of 6

DATE: 10-07-20 ✓
Quotation Expires: 12-08-20

REV 2

VERY IMPORTANT NOTE: As a supplier of equipment, Quinn Power Systems (QPS) disclaims responsibility for any and all permits or licenses necessary to design, install and operate the equipment due to zoning, air quality, building or construction codes or use permits pertaining to buyers or buyers' client's, particular application of such equipment or any similar type of permit.

Special attention should be given to the requirements of the local Air Quality Management District (AQMD) rules, regulations and permit process. As an equipment supplier, QPS is proposing equipment to specifications as indicated herein. If additional equipment or engine modifications are required beyond the specifications as required by AQMD and Best Available Control Technology (BACT) guidelines, those items are not included. For example, South Coast AQMD Rule 1470 requires controls and limits on particulate matter, especially when the engine installation is within 100-meters from a school. Unless specifically indicated in this proposal, compliance to this rule is the responsibility of others.

Ultra low sulfur fuel is required for particulate filters plus will be the required fuel starting in 2006.

When indicated in the bill of materials, the proposed equipment may be SCAQMD pre-approved as certified equipment. This certification does not eliminate the permit process or responsibility of others to obtain a permit. Procurement of certified equipment assures permitability, reduces the permit processing fees and reduces the time necessary to obtain the permit.

Only those items listed are included. Not included is any exhaust or fuel piping, main fuel tank, fuel, duct work, special tools, insulation, wiring, cable, bus duct, concrete, anchor bolts, rigging or any material or labor incidental to the installation itself.

If delivery is delayed by customer (Buyer) beyond original shipment date, purchase price is due 30 days after original shipment date and a hold charge of 1% per month (12% per annum) of the purchase price is due each month until delivery. Service charge of 1.5% per month (18% per annum) is applicable on any delinquent balance.

When included, delivery, startup assistance, field testing, training or any other services required on site will be provided during the normal weekday working hours of 7:00 am to 4:30 pm. Delivery or services occurring at any other time, weekends or holidays is subject to additional charges.

Terms and conditions of Caterpillar warranty apply. The Manufacturers' warranties are exclusive and in lieu of all other warranties either oral or written, express or implied, including but not limited to any warranty of merchantability or fitness for a particular purpose. QPSA is not a manufacturer and makes no warranty and shall not, under any circumstances, be liable for any indirect or special, incidental or consequential damages including but not limited to loss of production, loss of profit, loss of use or business interruption, or any other economic loss, whether arising from contract, tort, strict liability or any other theory of law.

If construction of the facility or other delays are experienced or expected, which prohibit the initial startup of the equipment beyond one year from delivery, additional costs should be anticipated. Additional costs might include, but not be limited to long term storage preparation, inspection charges, parts, service etc.

Terms of payment are net 30 days, no retentions; subject to credit approval. Per Company procedure, QPSA will file a California "Preliminary 20-day notice" applicable per Section 3097 of the California Civil Code.

Important conditions for export transactions. This transaction is for the sale of equipment only, as requested and as detailed in this proposal. Not included is any startup assistance, field-testing, training or any other services that might be required on site. Also not included is the responsibility of proper application and installation, installation audits, sea trials (if applicable), installation materials and the installation itself. To ensure proper application, installation, and warranty integrity, you are encouraged to contact the receiving Caterpillar Dealer for these services. The costs of these services are not included in the sale price nor will QPSA be responsible for any such related costs.



QUOTATION

AWA13351

3500 Shepherd Street, City of Industry, California 90601
Box 227044, Los Angeles, California 90022-0744

PAGE 5 of 6

DATE: 10-07-20 ✓
Quotation Expires: 12-08-20

REV 1

TERMS AND CONDITIONS

Acceptance of Order.

This Quotation is for Buyer's information only and is not a valid offer to sell unless signed by an officer of Seller in the place provided on the face of this Quotation. Prices, terms and conditions in an order from Buyer which are inconsistent with the prices, terms and conditions of this Quotation will be rejected by Seller, and are of no force and effect unless accepted in writing by Seller. Prices, delivery schedules and the scope of work on this Quotation are subject to change at Seller's discretion.

Liability.

Seller's liability on any claim of any kind, including claims for negligence, or for any loss or damage arising out of or connected with the manufacture, sale, delivery, resale or use of any products covered by or furnished under any order shall be limited to those claims arising solely from the acts of Seller and Seller shall in no way be liable for any special or consequential damages.

Any claims against Seller for shortages in shipments shall be made in writing to Seller within fifteen (15) days of receipt of shipment by Buyer. Unless otherwise provided for in writing, Seller's responsibility for shipment ceases upon delivery to carrier, and any claims for shortage, delays or damage occurring thereafter shall be made direct to carrier by Buyer.

Fulfillment of any order accepted by Seller is subject to strikes, labor disputes, lockouts, accidents, fires, delays in manufacture or in transportation, delays in delivery of component materials, floods, severe weather, or Acts of God, embargoes, governmental actions, or any other cause beyond the reasonable control of Seller.

Shipments.

Unless otherwise specified, shipment dates are approximate. Shipment of goods under any order accepted by Seller shall be subject to the approval by Seller of Buyer's financial condition at the time of shipment. Whether or not terms of payment are specified elsewhere, Seller may, at its option, condition shipments under any order accepted by Seller upon receipt of satisfactory security or of cash prior to shipment.

If, at Buyer's request, shipment of goods under any order accepted by Seller is delayed more than thirty (30) days after the shipment date specified in the order, or the date the goods are ready for shipment, whichever is later, Seller may require immediate payment in full and/or assess additional charges for the expenses incident to such delay.

Termination.

In the absence of a written agreement between Buyer and Seller expressing different terms and conditions as to termination, any order accepted by Seller may be terminated prior to completion by Buyer only upon written notice to Seller and payment of Seller's termination charges. If notice of termination is received by Seller after Seller has committed to buy the principal components for any order, termination charges shall include the total profit anticipated by Seller. Additionally, Buyer's instruction to Seller to stop work for thirty (30) days during the time specified for performance in any order may be construed by Seller as the equivalent of written notice of termination from Buyer.

Taxes.

Unless expressly stated, Seller's prices do not include sales, use, excise or similar taxes, which Seller may be required to pay in filling Buyer's order. The amount of any applicable tax shall be paid by Buyer as an additional charge unless specifically included in any order accepted by Seller, or in lieu thereof, the Buyer shall provide Seller with a tax exemption certificate acceptable to the taxing authorities.

Patents.

Seller shall, at its own expense, defend and save Buyer harmless from the expenses and consequences of any suit or procedure brought against Buyer, based on a claim that the use or sale of goods specified in any order accepted by Seller constitutes an infringement of any United States letters of patent in existence on the date of any such order; provided Buyer promptly notifies Seller in writing and gives the necessary authorization, information and assistance for the defense of such a claim.

Changes.



QUOTATION

AWA13351

3500 Shepherd Street, City of Industry, California 90601
Box 227044, Los Angeles, California 90022-0744

PAGE 6 of 6

DATE: 10-07-20 ✓
Quotation Expires: 12-08-20

REV 1

Seller, and Seller's suppliers, may, at any time, without notice to Buyer, make changes (whether in design, materials, the addition of improvements, or otherwise) in any goods specified in any order accepted by Seller without incurring any obligation of any kind as a result thereof, but only to the extent that such change does not cause the goods specified to fail to meet Buyer's requirements. Buyer may, in its order, provide for changes in its requirements with provision for a corresponding equitable change in the price, if any; but in no instance shall Buyer make changes, which are substantially different from the scope of the original order accepted by Seller.

Export Sales.

In the event the goods and services specified in any order accepted by Seller are for export, the Buyer shall be responsible for securing export, import and other licenses or authorizations as may be required.

The quotation provided herein is for information only, and is not a valid offer to sell unless signed by a Sales Representative of Quinn Power Systems and an officer of your Company in the space provided below. Any offer to sell or any offer accepted shall be subject to the Terms and Conditions page. Unless expressly stated on the face of this quotation, all prices, delivery schedules and product specifications are subject to change without notice. Quotation is good for 30 days, expires after that duration.

Signature: _____

Sales Representative: Allen Abramovitch

Cell: 805-431-3180

Office: 805-485-2171

Submitted By: Allen Abramovitch



ACCEPTED BY:

Company: _____

Signature: _____

Date: _____

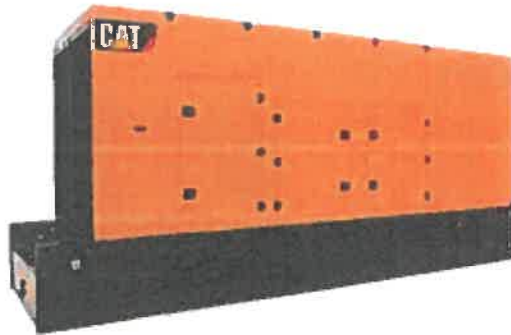

Image shown may not reflect actual configuration.

Sound Attenuated Enclosures for C27 and C32 Generator Sets

These sound attenuated, factory installed enclosures are designed for safety and aesthetic value. Rugged construction provides weather protection and the ability to withstand exposure to the elements.

Features and Benefits

Robust/Highly Corrosion-Resistant Construction

- Environmentally friendly, polyester powder-baked paint in Caterpillar yellow
- Zinc plated or stainless steel fasteners
- 14-gauge steel construction
- Pitched roof for improved rain ingress protection
- Critical grade internally mounted muffler/exhaust system
- Vibration spring isolators
- 75 dBA at 7 m

Excellent Access

- Control panel mounted on left side or right side of package
- Large cable entry area for ease of installation
- Left-hand or right-hand bottom entry access to power cable bus or circuit breaker
- Double doors on both sides
- Lube oil and coolant drains piped to exterior of enclosure and terminated drain valves

Options

- Interior AC lighting system and AC receptacles (interior and exterior)
- AC distribution box
- Interior DC lighting system with automatic shutoff timer
- Cold-weather bundle, including motorized louvers (powered closed), backdraft dampers, and enclosure space heater
- Caterpillar Yellow (default), white, grey, or beige paint
- 1000, 2000, and 3600 gallon fuel tanks
- 120 mph wind loading

Security and Safety

- Lockable access doors with standard key use
- Cooling fan and battery charging alternator fully guarded
- Oil fill and battery can only be reached via lockable access
- External fuel connections
- Externally mounted emergency stop button
- Designed for spreader-bar lifting to ensure safety

Certifications

- UL Listed
- Seismic certification per applicable building codes: IBC 2000, IBC 2003, IBC 2006, IBC 2009, IBC 2012, CBC 2007
- IBC certifiable for 120 mph wind loading
- Tested and analyzed in accordance with: ASCE 7-98, ASCE 7-02, ASCE 7-05, ICC-ES AC-156

Enclosure Weights and Dimensions

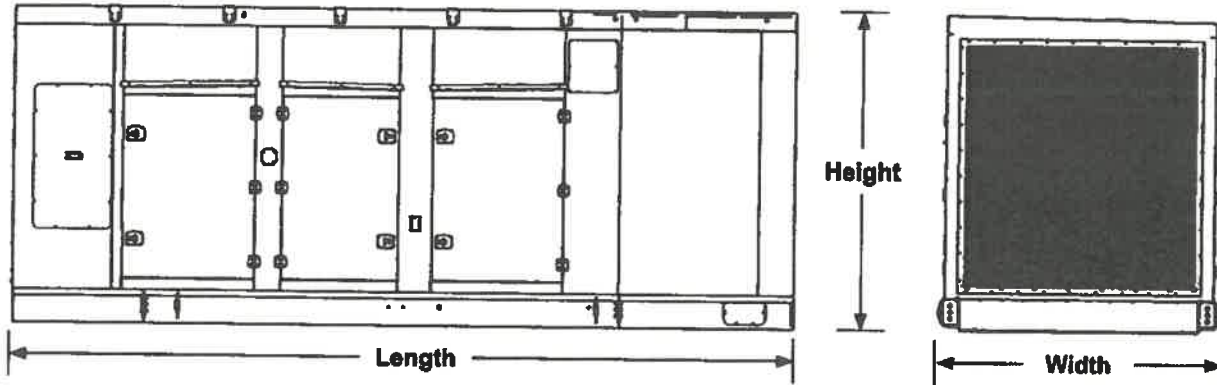

Note: For reference only – do not use for installation design. Please contact your dealer for exact weights and dimensions.

	Weight*		Length		Width		Height	
	kg	lbs	mm	in	mm	in	mm	in
Enclosure with sub base	3500	7716	7010	276	2554	101	2844	112
Enclosure with 1000 gal tank base	5920	13,051	7645	301	2554	101	3213	127
Enclosure with 2000 gal tank base	6050	13,338	7645	301	2554	101	3454	136
Enclosure with 3600 gal tank	7000	15,432	9750	384	2554	101	3759	148

*Weight does not include package generator set weight.

	Generator Set Weight**	
	kg	lbs
C27 Open Generator Set	6622	14,600
C32 Open Generator Set	6668	14,700

**Dry weight

Note: For reference only – do not use for installation design. Please contact your dealer for exact weights and dimensions.

<http://www.cat.com/powergeneration>

©2017 Caterpillar
All rights reserved.

Materials and specifications are subject to change without notice.
The International System of Units (SI) is used in this publication.

CAT, CATERPILLAR, their respective logos, "Caterpillar Yellow", the "Power Edge" trade dress as well as corporate and product identity used herein, are trademarks of Caterpillar and may not be used without permission.

Weights and Dimensions

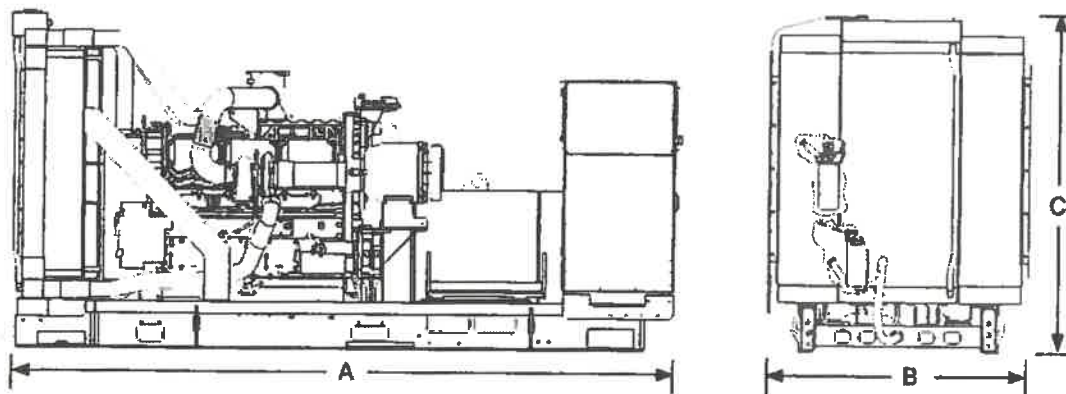

Dim "A" mm (in)	Dim "B" mm (in)	Dim "C" mm (in)	Dry Weight kg (lb)
4165 (164.0)	1684 (66.3)	2162 (85.1)	6668 (14,700)

Note: For reference only. Do not use for installation design. Contact your local Cat dealer for precise weights and dimensions.

Ratings Definitions

Standby

Output available with varying load for the duration of the interruption of the normal source power. Average power output is 70% of the standby power rating. Typical operation is 200 hours per year, with maximum expected usage of 500 hours per year.

Mission Critical

Output available with varying load for the duration of the interruption of the normal source power. Average power output is 85% of the mission critical power rating. Typical peak demand up to 100% of rated power for up to 5% of the operating time. Typical operation is 200 hours per year, with maximum expected usage of 500 hours per year.

Prime

Output available with varying load for an unlimited time. Average power output is 70% of the prime power rating. Typical peak demand is 100% of prime rated kW with 10% overload capability for emergency use for a maximum of 1 hour in 12. Overload operation cannot exceed 25 hours per year.

Continuous

Output available with non-varying load for an unlimited time. Average power output is 70-100% of the continuous power rating. Typical peak demand is 100% of continuous rated kW for 100% of the operating hours.

Applicable Codes and Standards

AS 1359, CSA C22.2 No. 100-04, UL 142, UL 489, UL 869, UL 2200, NFPA 37, NFPA 70, NFPA 99, NFPA 110, IBC, IEC 60034-1, ISO 3046, ISO 8528, NEMA MG1-22, NEMA MG1-33, 2014/35/EU, 2006/42/EC, 2014/30/EU.

Note: Codes may not be available in all model configurations. Please consult your local Cat dealer for availability.

Data Center Applications

- ISO 8528-1 Data Center Power (DCP) compliant per DCP application of Cat diesel generator set prime power rating.
- All ratings Tier III/Tier IV compliant per Uptime Institute requirements.
- All ratings ANSI/TIA-942 compliant for Rated-1 through Rated-4 data centers.

Fuel Rates

Fuel rates are based on fuel oil of 35° API [16°C (60°F)] gravity having an LHV of 42,780 kJ/kg (18,390 Btu/lb) when used at 29°C (85°F) and weighing 838.9 g/liter (7.001 lbs/U.S. gal.)

www.cat.com/electricpower

©2019 Caterpillar
All rights reserved.

Materials and specifications are subject to change without notice. The International System of Units (SI) is used in this publication.

Package Performance

Performance	Standby	Mission Critical	Prime	Continuous
Frequency	60 Hz	60 Hz	60 Hz	60 Hz
Gen set power rating with fan	1000 ekW	1000 ekW	910 ekW	830 ekW
Gen set power rating with fan @ 0.8 power factor	1250 kVA	1250 kVA	1138 kVA	1038 kVA
Fueling strategy	EPA ESE (Tier 2)	EPA ESE (Tier 2)	EPA ESE (Tier 2)	EPA ESE (Tier 2)
Performance number	DM9933-03	EM0449-00	DM9934-04	DM9935-03
Fuel Consumption				
100% load with fan – L/hr (gal/hr)	272.1 (71.9)	272.1 (71.9)	248.6 (65.7)	232.1 (61.3)
75% load with fan – L/hr (gal/hr)	213.4 (56.4)	213.4 (56.4)	197.0 (52.0)	176.5 (46.6)
50% load with fan – L/hr (gal/hr)	144.7 (38.2)	144.7 (38.2)	134.2 (35.5)	122.9 (32.5)
25% load with fan – L/hr (gal/hr)	82.6 (21.8)	82.6 (21.8)	78.5 (20.7)	73.4 (19.4)
Cooling System				
Radiator air flow restriction (system) – kPa (in. water)	0.12 (0.48)	0.12 (0.48)	0.12 (0.48)	0.12 (0.48)
Radiator air flow – m ³ /min (cfm)	1175 (41494)	1175 (41494)	1175 (41494)	1175 (41494)
Engine coolant capacity – L (gal)	55.0 (14.5)	55.0 (14.5)	55.0 (14.5)	55.0 (14.5)
Radiator coolant capacity – L (gal)	36.0 (9.0)	36.0 (9.0)	36.0 (9.0)	36.0 (9.0)
Total coolant capacity – L (gal)	91.0 (23.5)	91.0 (23.5)	91.0 (23.5)	91.0 (23.5)
Inlet Air				
Combustion air inlet flow rate – m ³ /min (cfm)	87.6 (3094.1)	87.6 (3094.1)	83.7 (2954.5)	80.0 (2825.6)
Exhaust System				
Exhaust stack gas temperature – °C (°F)	476.4 (889.5)	476.4 (889.5)	459.5 (859.1)	461.2 (862.1)
Exhaust gas flow rate – m ³ /min (cfm)	228.4 (8065.3)	228.4 (8065.3)	212.1 (7488.7)	204.8 (7231.2)
Exhaust system backpressure (maximum allowable) – kPa (in. water)	6.7 (27.0)	6.7 (27.0)	6.7 (27.0)	6.7 (27.0)
Heat Rejection				
Heat rejection to jacket water – kW (Btu/min)	352 (20033)	352 (20033)	327 (18624)	307 (17468)
Heat rejection to exhaust (total) – kW (Btu/min)	1024 (58206)	1024 (58206)	933 (53072)	896 (50940)
Heat rejection to aftercooler – kW (Btu/min)	288 (16385)	288 (16385)	255 (14526)	230 (13082)
Heat rejection to atmosphere from engine – kW (Btu/min)	127 (7238)	127 (7238)	116 (6625)	114 (6486)
Heat rejection from alternator – kW (Btu/min)	55 (3131)	55 (3131)	50 (2846)	45 (2561)
Emissions* (Nominal)				
NOx mg/Nm ³ (g/hp-h)	2348.6 (4.93)	2348.6 (4.93)	2293.5 (4.81)	1969.0 (4.23)
CO mg/Nm ³ (g/hp-h)	62.1 (0.13)	62.1 (0.13)	59.2 (0.12)	52.5 (0.11)
HC mg/Nm ³ (g/hp-h)	5.5 (0.01)	5.5 (0.01)	7.0 (0.02)	12.7 (0.03)
PM mg/Nm ³ (g/hp-h)	7.2 (0.02)	7.2 (0.02)	6.6 (0.02)	7.1 (0.02)
Emissions* (Potential Site Variation)				
NOx mg/Nm ³ (g/hp-h)	2841.6 (5.97)	2841.6 (5.97)	2775.2 (5.83)	2382.5 (5.11)
CO mg/Nm ³ (g/hp-h)	116.1 (0.24)	116.1 (0.24)	110.6 (0.23)	98.1 (0.21)
HC mg/Nm ³ (g/hp-h)	10.3 (0.03)	10.3 (0.03)	13.2 (0.03)	24.1 (0.06)
PM mg/Nm ³ (g/hp-h)	14.1 (0.04)	14.1 (0.04)	12.9 (0.03)	13.9 (0.04)

*mg/Nm³ levels are corrected to 5% O₂. Contact your local Cat dealer for further information.

Optional Equipment

Engine

Air Cleaner

- Single element
- Dual element
- Heavy duty

Muffler

- Industrial grade (15 dB)

Starting

- Standard batteries
- Oversized batteries
- Standard electric starter
- Dual electric starter
- Jacket water heater

Alternator

Output voltage

- 220V 480V
- 240V 600V
- 380V 2400V
- 400V 4160V

Temperature Rise (over 40°C ambient)

- 150°C
- 125°C/130°C
- 105°C
- 80°C

Winding type

- Random wound
- Form wound

Excitation

- Self excited
- Internal excitation (IE)
- Permanent magnet (PM)

Attachments

- Anti-condensation heater
- Stator and bearing temperature monitoring and protection

Power Termination

Type

- Bus bar
- Circuit breaker
- 400A 800A
- 1200A 1600A
- 2000A 2500A
- 3000A 3200A
- UL IEC
- 3-pole 4-pole
- Manually operated
- Electrically operated

Trip Unit

- LSI LSI-G
- LSI-G-P

Factory Enclosure

- Weather protective
- Sound attenuated

Attachments

- Cold weather bundle
- DC lighting package
- AC lighting package
- Motorized louvers

Fuel Tank

- Sub-base
- 1000 gal (3875 L)
- 2000 gal (7570 L)
- 3600 gal (13627 L)

Control System

Controller

- EMCP 4.2B
- EMCP 4.3
- EMCP 4.4

Attachments

- Local annunciator module
- Remote annunciator module
- Expansion I/O module
- Remote monitoring software

Charging

- Battery charger – 10A

Vibration Isolators

- Rubber
- Spring
- Seismic rated

Cat Connect

Connectivity

- Ethernet
- Cellular
- Satellite

Extended Service Options

Terms

- 2 year (prime)
- 3 year
- 5 year
- 10 year

Coverage

- Silver
- Gold
- Platinum
- Platinum Plus

Ancillary Equipment

- Automatic transfer switch (ATS)
- Uninterruptible power supply (UPS)
- Paralleling switchgear
- Paralleling controls

Certifications

- UL 2200 Listed
- CSA
- IBC seismic certification
- OSHPD pre-approval

Note: Some options may not be available on all models. Certifications may not be available with all model configurations. Consult factory for availability.

Cat® C32

Diesel Generator Sets



Image shown may not reflect actual configuration

Bore – mm (in)	145 (5.7)
Stroke – mm (in)	162 (6.4)
Displacement – L (in³)	32.1 (1959)
Compression Ratio	15.0:1
Aspiration	TA
Fuel System	EUI
Governor Type	ADEM™ A4

Standby 60 Hz ekW (kVA)	Mission Critical 60 Hz ekW (kVA)	Prime 60 Hz ekW (kVA)	Continuous 60 Hz ekW (kVA)	Emissions Performance
1000 (1250)	1000 (1250)	910 (1137)	830 (1038)	U.S. EPA Certified for Emergency Stationary Applications (Tier 2)

Standard Features

Cat® Diesel Engine

- Designed and tested to meet the U.S. EPA Emergency Stationary (Tier 2) emissions
- Reliable and consistent performance proven in thousands of applications worldwide

Generator Set Package

- Accepts 100% block load in one step and meets NFPA 110 loading requirements
- Conforms to ISO 8528-5 G3 load acceptance requirements.
- Reliability is verified through prototype testing, which includes torsional vibration, fuel consumption, oil consumption, transient performance, and endurance testing

Alternators

- Superior motor starting capability minimizes the need for oversizing the generator
- Designed to match the performance and output characteristics of Cat diesel engines

Cooling System

- Cooling systems available to operate in ambient temperatures up to 50°C (122°F)
- Tested to ensure proper generator set cooling

EMCP 4 Control Panels

- User-friendly interface and navigation
- Scalable system to meet a wide range of installation requirements
- Expansion modules and site specific programming for specific customer requirements

Warranty

- 24 months/1000-hour warranty for standby and mission critical ratings
- 12 months/unlimited hour warranty for prime and continuous ratings
- Extended service protection is available to provide extended coverage options

Worldwide Product Support

- Cat dealers have over 1,800 dealer branch stores operating in 200 countries
- Your local Cat dealer provides extensive post-sale support, including maintenance and repair agreements

Financing

- Caterpillar offers an array of financial products to help you succeed through financial service excellence
- Options include loans, finance lease, operating lease, working capital, and revolving line of credit
- Contact your local Cat dealer for availability in your region

