

Project: **OAHS Multi-Use Room Building**
Project No. 2-2022-02-22-01
 Orcutt Academy High School
 610 Pinal Ave, Orcutt, CA 93455

Owner: Orcutt Union School District
 500 Dyer Street
 Orcutt, CA 93455

Architect: 19six Architects
 560 Higuera Street, Suite C
 San Luis Obispo, CA 93401

Construction Manager: TELACU Construction Management
 604 N. Eckhoff Street
 Orange, CA 92868

BID ADDENDUM 08

Revision: **May 23, 2022**

Note: The following revisions and clarifications to the Bid Documents (plans and specifications) shall become a part of the Contract Documents upon award of Bid. All Bidders are required to incorporate all necessary changes, additions, or deductions into their proposals.

In case of conflict between Bid Documents and this Addendum, this Addendum shall govern. Bidder shall acknowledge receipt of this Addendum on the Bid Form as noted in the Instruction to Bidders, failure to do so may subject Bidder to disqualification.

Volume II – Technical Specifications and Reports

1. Refer to **Addendum 05 by 19-6 Architects** which is attached hereto

Volume III – Bid Set Drawings

1. Refer to **Addendum B by 19-6 Architects** which is attached hereto
2. Refer to **Addendum 05 by 19-6 Architects** which is attached hereto

Pre-Bid RFI:

1. See attached responses to Pre-Bid RFI #18.

Prepared by,
 TELACU Construction Management

Attachments:

1. Addendum B by 19-6 Architects - Orcutt Academy MUR dated May 20, 2022
2. Addendum 05 by 19-6 Architects - Orcutt Academy MUR dated May 23, 2022

ADDENDUM NO. B

Project: Orcutt Union School District
Orcutt Academy High School
Multi-Use Room Building
19six No. 20179.01
DSA App. No.: 03-121912 File No.: N/A
Bid No.:

Date: May 20, 2022

To all bidders submitting proposals for the above captioned project. This Addendum is hereby included in the Contract Documents to the same extent as though it were originally included therein. The following items modify, add to, delete from, or explain the drawings and/or specifications. The contents of this Addendum shall take precedence over the original specifications and plans.

DRAWINGS

- Item #1:** **Landscaping.** Revise landscaping and irrigation plans. See revised sheets L-101, L-201, G-101 and A-101.
- Item #2:** **Future EV Charging Stations.** Revise number of future EV charging stations from 2 to 4. Add location of additional future EV charger. See revised sheets A-101 and E-101.
- Item #3:** **Bike Rack.** Add one additional 7-capacity bike rack. Provide total capacity for 14 bikes. Add product information for bike rack on detail 25 of sheet A-111. See revised sheets G-101, A-101 and A-111.

ATTACHMENTS:

G-101 CODE SITE PLAN
L-101 PLANTING PLAN
L-201 IRRIGATION PLAN
A-101 SITE PLAN
A-111 SITE DETAILS
E-101 SITE ELECTRICAL PLAN



Alan Kroeker

C-22474

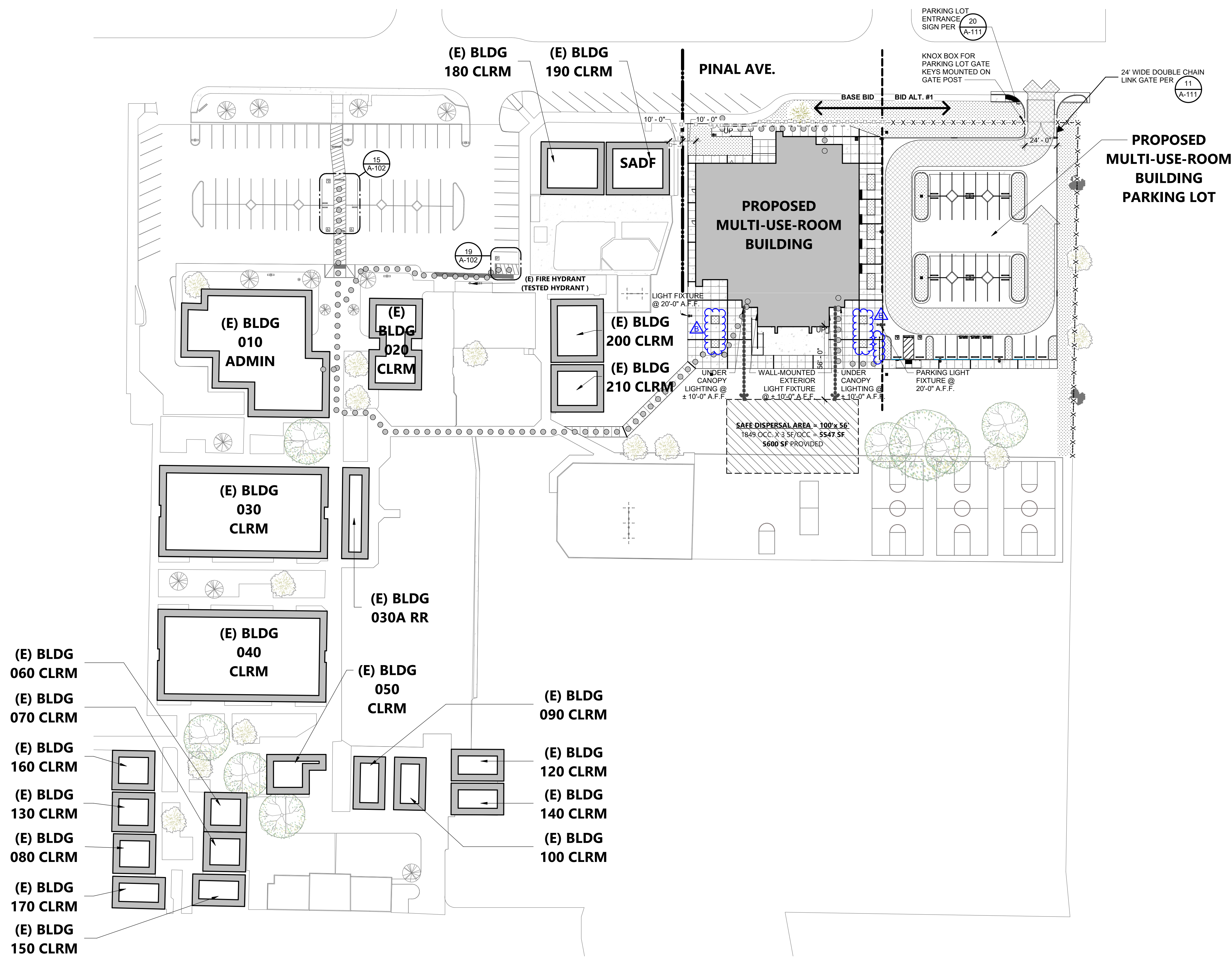

LEGEND

- ASSUMED PROPERTY LINE
- PROJECT BUILDING
- (E) BUILDING
- FIRE APPARATUS ACCESS LANE, MIN. 20FT WIDE
- PATH OF TRAVEL (P.O.T.)
 - AS INDICATED, IS A COMMON BARRIER FREE ACCESS ROUTE
 - IS AT LEAST 48" WIDE
 - NO ABRUPT VERTICAL CHANGES EXCEEDING 1/2" BEVELED AT 1:2 MAXIMUM SLOPE, EXCEPT THAT LEVEL CHANGES DO NOT EXCEED 1/4" VERTICAL
 - THE PATH SURFACE IS SLIP RESISTANT, STABLE, FIRM, AND SMOOTH.
 - PASSING SPACES (11B-403.2) NOT MORE THAN 400' APART
 - PARTS OF P.O.T. WITH CONTINUOUS GRADIENTS HAVE 60" LEVEL AREAS (11B-403.2) NOT MORE THAN 400' APART
 - THE CROSS-SLOPE DOES NOT EXCEED 2% AND SLOPE IN THE DIRECTION OF TRAVEL IS LESS THAN 5% UNLESS OTHERWISE INDICATED.
 - (POT) SHALL BE MAINTAINED FREE OF OVERHANGING OBSTRUCTIONS TO 80" MINIMUM (11B-307.4) AND PROTRUDING OBJECTS GREATER THAN 4" PROJECTION FROM WALL AND ABOVE 27" AND LESS THAN 80" (11B-307).
 - ARCHITECT SHALL VERIFY PATH OF TRAVEL CONFORMS WITH THE ABOVE.
 - DESIGN PROFESSIONAL IN GENERAL RESPONSIBLE CHARGE STATEMENT: THE P.O.T. IDENTIFIED IN THESE CONSTRUCTION DOCUMENTS MEETS THE REQUIREMENTS OF THE CURRENT APPLICABLE CALIFORNIA BUILDING CODE (CBC) ACCESSIBILITY PROVISIONS FOR PATH OF TRAVEL REQUIREMENTS FOR ALTERATION, ADDITIONS, AND STRUCTURAL REPAIRS AS PART OF THE DESIGN OF THIS PROJECT. THE P.O.T. WAS EXAMINED AND ANY ELEMENTS, COMPONENTS, OR PORTIONS OF THE P.O.T. THAT WERE DETERMINED TO BE NON-COMPLIANT WITH CBC HAVE BEEN IDENTIFIED AND THE CORRECTIVE WORK NECESSARY TO BRING THEM INTO COMPLIANCE HAS BEEN INCLUDED WITHIN THE SCOPE OF THE PROJECT'S WORK THROUGH DETAILS, DRAWINGS AND SPECIFICATIONS INCORPORATED INTO THESE CONSTRUCTION DOCUMENTS. ANY NON-COMPLIANT ELEMENTS, COMPONENTS, OR PORTIONS OF THE P.O.T. THAT WILL NOT BE CORRECTED BY THIS PROJECT BASED ON VALUATION THRESHOLD LIMITATIONS OR A FINDING OF UNREASONABLE HARDSHIP ARE INDICATED IN THESE CONSTRUCTION DOCUMENTS.
 - DURING CONSTRUCTION, IF P.O.T. ITEMS WITHIN THE SCOPE OF THE PROJECT REPRESENTED AS CBC COMPLIANT ARE FOUND TO BE NON-COMPLIANT BEYOND REASONABLE CONSTRUCTION TOLERANCES, THE ITEMS SHALL BE BROUGHT INTO COMPLIANCE WITH THE CBC AS PART OF THE PROJECT BY MEANS OF A CONSTRUCTION CHANGE DOCUMENT.
- CHAIN LINK GATE, SWINGING TYPE
 - ALLOWS MANUAL OPERATION BY ONE PERSON
 - SHALL BE MAINTAINED IN AN OPERATIVE CONDITION AT ALL TIMES AND REPLACED OR REPAIRED WHEN DEFECTIVE
 - SEE 11 A-111
- FENCE LINE
- DECORATIVE FENCE LINE
- EXIT DISCHARGE PATH TO SAFE DISPERSAL AREA

FIRE FLOW

REQUIRED FIRE FLOW PER 2019 CFC APPENDIX BB	TYPE V-B @ 14.618 SF	*3,250 GPM / 1,500 GPM WITH REDUCTION PER CFC BB105.1
PROVIDED FIRE FLOW		*3,000 GPM

*MEASURED AT 20 PSI

Golden State Water Company
A Division of American States Water Company

08/05/2021

Hazel Cruz
19six Architects
560 Higuera St., Suite C
San Luis Obispo, CA 93401

Re: Orcutt Academy High School – 610 Pinal Avenue

This letter is in response to your request for a fire flow report for Orcutt Academy High School located at 610 Pinal Avenue. The request is for the fire hydrant adjacent to the school, FH #802 located at 805 Pinal Avenue. We have performed a physical fire flow and hydraulic model emulation of the water system to determine the static pressure and flow availability at 20 psi residual pressure. The physical fire flow represents a moment in time that may or may not reflect actual fire flow availability depending on the time of day fire flow is required. In light of this, this report provides the hydraulic model emulation of the available flow based on our maximum day demand model. The results based on the hydraulic model emulation are as follows:

FH #802
Static Pressure = 69 psi
Flow @ 20 psi = 3000 GPM
Capacity Duration > 4 hrs

Sincerely,
Joshua P. Alvidrez
Operations Engineer – Coastal District
Golden State Water Company

196 ARCHITECTS

560 HIGUERA STREET, SUITE C
SAN LUIS OBISPO, CA 93401
TEL (805) 476-0399

- CONSULTANTS**
- CIVIL ENGINEER**
STANTEC CONSULTING SERVICES INC.
111 East Victoria Street
Santa Barbara, CA 93101
TEL (805) 680-6830
 - LANDSCAPE ARCHITECT**
OASIS ASSOCIATES
3427 Miguelito Court
San Luis Obispo, CA 93401
TEL (805) 541-4509
 - STRUCTURAL ENGINEER**
STORK, WOLFE & ASSOCIATES
555 Chorro Street, Suite A1
San Luis Obispo, CA 93405
TEL (805) 548-8600
 - MECHANICAL ENGINEER**
BMA MECHANICAL +
100 Cross Street, Suite 204
San Luis Obispo, CA 93401
TEL (805) 544-4269
 - ELECTRICAL ENGINEER**
THOMA ENGINEERING
3562 Empeo, Suite C
San Luis Obispo, CA 93406
TEL (805) 543-3850
 - FIRE PROTECTION ENGINEER**
BMA MECHANICAL +
100 Cross Street, Suite 204
San Luis Obispo, CA 93401
TEL (805) 544-42-69

ARCHITECT STAMP

CONSULTANT STAMP

LICENSED ARCHITECT
A-141 ELEN FREDER
C-22474
ALICE CRUZ
STATE OF CALIFORNIA

REVISIONS

NO.	DATE	DESCRIPTION
1	04-19-2022	Addendum 1
A	05-19-2022	ADDENDUM A
B	05-20-2022	ADDENDUM B

THE ARCHITECT DOES NOT REPRESENT THAT THESE PLANS OR THE SPECIFICATIONS ARE SUITABLE FOR ANY SITE OTHER THAN THE ONE FOR WHICH THEY WERE SPECIFICALLY PREPARED. THE ARCHITECT DISCLAIMS RESPONSIBILITY FOR THESE PLANS AND SPECIFICATIONS IF THEY ARE USED IN WHOLE OR IN PART AT ANY OTHER SITE.

PROJECT OWNER & TITLE
ORCUTT UNION SCHOOL DISTRICT
500 Dyer Street
Orcutt, CA 93455

ORCUTT ACADEMY HS MUR BUILDING
610 Pinal Avenue
Orcutt, CA 93455

SHEET TITLE
CODE SITE PLAN

DRAWN BY: FC, HC JOB NUMBER: 20179.01

SHEET NO.
G-101
DATE: MAY 20, 2022

CODE SITE PLAN 1" = 40'-0" 1

MUR BLDG PARKING LOT ANALYSIS

TOTAL NUMBER OF STALLS	NUMBER OF ACC. STALLS REQUIRED	NUMBER OF ACC. STALLS PROVIDED	NUMBER OF VAN ACC. STALLS REQUIRED	NUMBER OF VAN ACC. STALLS PROVIDED
39	2	2	1	1

EXISTING PARKING LOT ANALYSIS

TOTAL NUMBER OF STALLS	NUMBER OF ACC. STALLS REQUIRED	NUMBER OF ACC. STALLS PROVIDED	NUMBER OF VAN ACC. STALLS REQUIRED	NUMBER OF VAN ACC. STALLS PROVIDED
80	4	4	1	1

BUILDING INFORMATION

BLDG NO.	DESCRIPTION	D.S.A. APPLICATION # (YEAR)	CERTIFICATION # (DATE)
010	ADMIN / MULT-USE	A# 18140 (1959)	#1 (8/21/1960)
010	ADMIN / MULT-USE	A# 49494 (1988)	#1 (7/21/1989)
010	ADMIN / MULT-USE	A# 03-102273 (2001)	#1 (5/23/2006)
010	ADMIN / MULT-USE	A# 03-104880 (2005)	#1 (4/19/2006)
010	ADMIN / MULT-USE	A# 03-115040 (2014)	#1 (1/20/2015)
020	CLASSROOM/SERVING LINE	A# 18140 (1959)	#1 (8/21/1960)
020	CLASSROOM/SERVING LINE	A# 03-102273 (2001)	#1 (5/23/2006)
020	CLASSROOM/SERVING LINE	A# 03-113888 (2011)	#1 (2/01/2013)
030	CLASSROOMS	A# 18140 (1959)	#1 (8/21/1960)
030	CLASSROOMS	A# 03-102273 (2001)	#1 (5/23/2006)
030A	RESTROOMS	A# 03-102273 (2001)	#1 (5/23/2006)
030A	RESTROOMS	A# 03-113888 (2011)	#1 (2/01/2013)
040	CLASSROOMS	A# 18140 (1959)	#1 (8/21/1960)
040	CLASSROOMS	A# 03-102273 (2001)	#1 (5/23/2006)
050	CLASSROOMS	A# 20918 (1961)	#1 (1/07/1963)
050	CLASSROOMS	A# 03-102273 (2001)	#1 (5/23/2006)
060	CLASSROOM	A# 49057 (1987)	#2 (11/27/2018)
070	CLASSROOM	A# 49057 (1987)	#2 (11/27/2018)
080	CLASSROOM	A# 50001 (1987)	#2 (2/25/1998) (COND./SSF)
090	CLASSROOM	A# 49412 (1986)	#1 (7/08/1993)
100	CLASSROOM	A# 51829 (1988)	#1 (4/03/1995)
120	CLASSROOM	A# 62585 (1996)	#1 (8/25/2004)
130	CLASSROOM	A# 68481 (1997)	#1 (3-03-2004)
140	CLASSROOM	A# 69117 (1997)	#1 (10/30/2001)
150	CLASSROOM	A# 69620 (1997)	#1 (6/07/2000)
160	CLASSROOM	A# 03-100712 (1998)	#1 (12/09/2002)
170	CLASSROOM	A# 03-106578 (2002)	#1 (4/21/2004)
180	CLASSROOM	A# 03-104482 (2000)	#1 (3/16/2005)
190	CLASSROOM	A# 03-104482 (2000)	#1 (3/16/2005)
200	MULTI-USE	A# 03-106546 (2002)	#1 (4/06/2004)
210	CLASSROOM	A# 03-106958 (2004)	#1 (5/24/2005)

DSA FORM 810

FIRE & LIFE SAFETY SITE CONDITIONS SUBMITTAL

Division of the State Architect (DSA) documents referenced within this publication are available on the **DSA Forms** or **DSA Publications** webpages.

To facilitate the Division of the State Architect's (DSA) fire and life safety plan review of project site conditions, DSA requires the design professional to provide the following information at time of project submittal for projects consisting of construction of a new campus, construction of new building(s), additions to existing buildings, and for site alternate design means for fire department emergency vehicle access, and fire suppression water supply.

Information associated with compliance items 1 through 3 below is to be provided for all project types indicated above. Information associated with items 4 through 7 is to be completed when an alternate means is utilized. Acknowledgement by the school district and signature from the Local Fire Authority (LFA) is only required when an alternate design means is being requested.

The Project Information and Fire & Life Safety Information sections are to be completed for all projects and imaged onto the fire access site plan. When an alternate design/means is proposed, all sections on pages 1 and 2 are to be completed and imaged on the fire access site plan.

For additional information refer to the instructions at the end of this form and DSA Policy PL 09-01: Fire Flow for Buildings.

PROJECT INFORMATION			
School District/Owner:	Orcutt Union School District		
Project Name/School:	Orcutt Academy High School Multi-Use Room Building		
Project Address:	610 Pinal Ave., Orcutt, CA 93455		

FIRE & LIFE SAFETY INFORMATION			
1. Has a fire hydrant flow test been performed within the past 12 months? (If yes, provide a copy of the test data.)	Yes <input checked="" type="checkbox"/>	No <input type="checkbox"/>	
2. Was the fire hydrant water flow test performed as part of this LFA review?	Yes <input checked="" type="checkbox"/>	No <input type="checkbox"/>	
3. Is the project located within a designated fire hazard severity zone (FHSZ) as established by Cal-Fire? (If yes, indicate FHSZ classification below.)	Yes <input checked="" type="checkbox"/>	No <input type="checkbox"/>	
Refer to the following website for FHSZ locations: http://www.fire.ca.gov/FHSZ/	Moderate <input type="checkbox"/>	High <input type="checkbox"/>	Very High <input type="checkbox"/>
Wildland Interface Area (WIFA) (If any designations are checked, project design must meet the requirements of CBC Chapter 7A.)			WIFA <input type="checkbox"/>

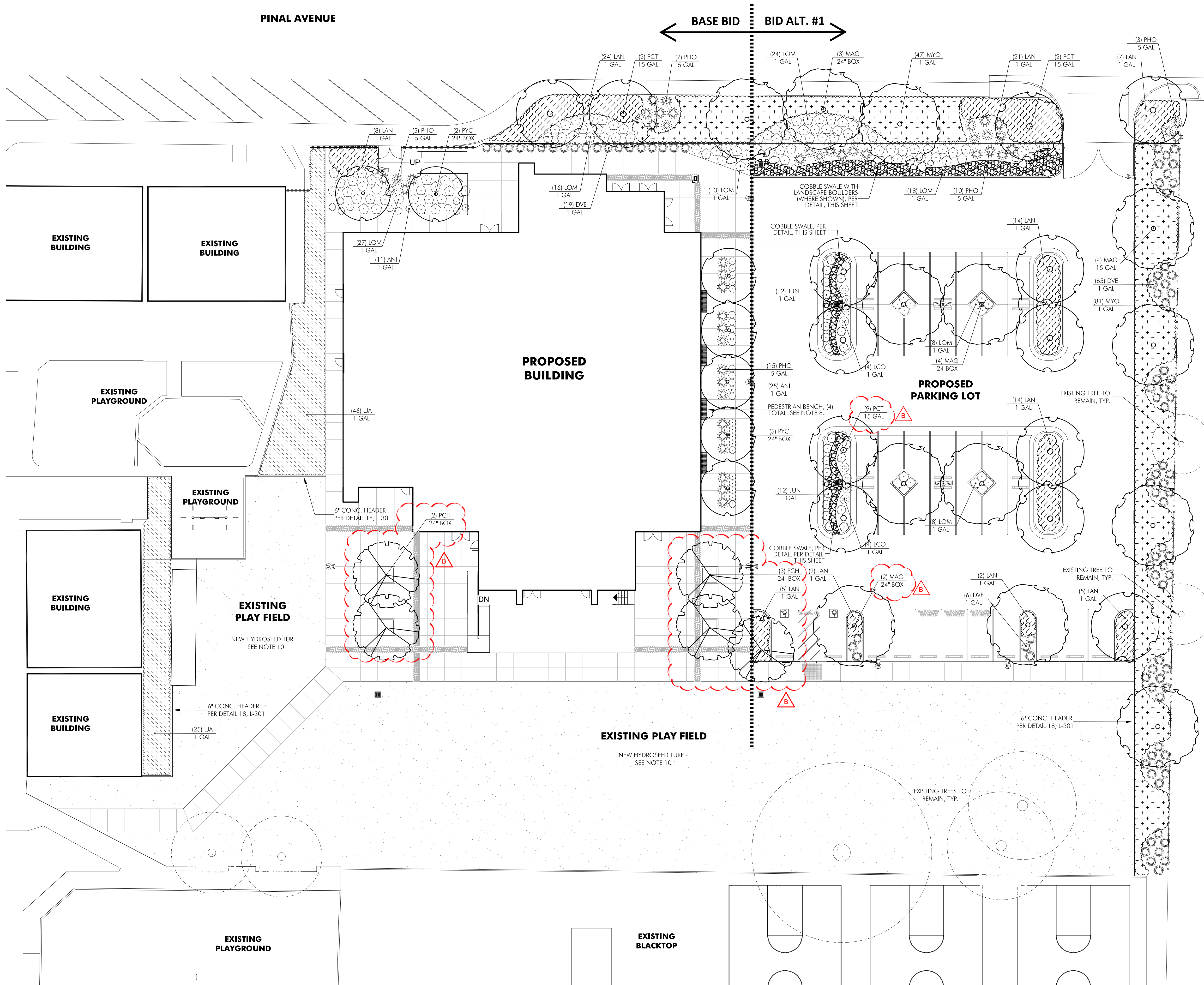

PLANT LEGEND

TREES	BOTANICAL / COMMON NAME	WUCOLS	QTY.	SIZE	NOTES
	MAG Magnolia grandiflora 'Samuel Sommer' SOUTHERN MAGNOLIA	M	7	24" BOX 15 GAL	DETAILS 2a, 2b, 2c
	PCH Pistacia chinensis CHINESE PISTACHE	L	5	24" BOX	DETAILS 2a, 2b, 2c
	PCT Prunus cerasifera 'Thundercloud' PURPLE LEAF PLUM	L	13	15 GAL	DETAILS 2a, 2b, 2c
	PYC Pyrus calleryana 'Chanticleer' ORNAMENTAL PEAR	M	7	24" BOX	DETAILS 2a, 2b, 2c

SHRUBS / PERENNIALS	BOTANICAL / COMMON NAME	WUCOLS	QTY.	SIZE	NOTES
	ANI Anigozanthos 'Bush Ranger' KANGAROO PAW	L	36	1 GAL	DETAIL 1a
	LOM Lomandra longifolia 'Breeze' DWARF MAT RUSH	L	114	1 GAL	DETAIL 1a
	JUN Juncus patens CALIFORNIA GREY RUSH	L	24	1 GAL	DETAIL 1a
	LCP Leymus condensatus 'Canyon Prince' CANYON PRINCE WILD RYE	L	8	1 GAL	DETAIL 1a
	PHO Phormium 'Yellow Wave' NEW ZEALAND FLAX	L	47	5 GAL	DETAIL 1a
	DVE Dietsia vegata FORTNIGHT LILY	L	90	1 GAL	DETAIL 1a

GROUNDCOVER	BOTANICAL / COMMON NAME	WUCOLS	QTY.	SIZE	NOTES
	LJA Lonicera japonica 'Haliann' JAPANESE HONEYSUCKLE	L	71	1 GAL 5" O.C.	DETAIL 1a, 3a
	LAN Lantana montevidensis TRAILING LANTANA	L	102	1 GAL 4" O.C.	DETAIL 1a, 3a
	MYO Myoporum parvifolium 'Putah Creek' CREEPING MYOPORUM	L	128	1 GAL 5" O.C.	DETAIL 1a, 3a

PLANTING NOTES

- CONTRACTOR TO PERFORM SPRAY AND KILL OPERATION ON ALL PLANTER AREAS THAT ONCE HAD TURF GROWING. REFER TO PLANTING SPECIFICATIONS FOR MORE INFO.
- QUANTITIES AND SIZES SHOWN IN THE PLANT LEGEND ARE FOR REFERENCE ONLY AND SHALL BE VERIFIED BY THE CONTRACTOR. NOTIFY PROJECT LANDSCAPE ARCHITECT OF ANY MAJOR DISCREPANCIES.
- ALL PLANTER AREAS, AS DESIGNATED ON THE PLAN, SHALL BE PREPARED AND AMENDED PER THE SPECIFICATIONS. SOIL AMENDMENTS AND PREPARATION SHALL CONFORM TO STATE AB1881 AND LOCAL WATER EFFICIENT LANDSCAPE ORDINANCES.
- ALL TREES PLANTED WITHIN 7' OF HARDSCAPE OR STRUCTURES SHALL BE INSTALLED WITH A DEEP ROOT PLANTER, PER DETAIL 2B.
- INSTALL MINIMUM 3" THICK BARK MULCH IN ALL PLANTING AREAS. REFER TO SPECIFICATIONS FOR TYPE. PROVIDE SAMPLE FOR APPROVAL.
- ADJUST PLANT MATERIAL AS NECESSARY AROUND UTILITY LOCATIONS. NOTIFY LANDSCAPE ARCHITECT AND/OR DISTRICT OF ANY MAJOR CONFLICTS OR NECESSARY ADJUSTMENTS.
- REVIEW THE PLANTING AND IRRIGATION SPECIFICATIONS PRIOR TO BIDDING. IF NOT PROVIDED, CONTACT THE LANDSCAPE ARCHITECT.
- BENCH (QTY. 4) SHALL BE "RB-28". SIZE: 8' LONG, WITH INTERMEDIATE ARM REST. COLOR: BLACK. SURFACE MOUNT PER MANF'S INSTRUCTIONS. AVAILABLE FROM VICTOR STANLEY: 800-368-2573
- ANY EXISTING VEGETATION TO REMAIN AND NEWLY PROPOSED VEGETATION WILL BE PROPERLY MAINTAINED BY THE DISTRICT IN PERPETUITY AND IN ACCORDANCE WITH CBC 701A.5.
- FOR ALL TURF AREAS, CONTRACTOR SHALL PERFORM SPRAY AND KILL OPERATION AND SCALP TO REMOVE ALL EXISTING TURF; FINE GRADE, ROLL AND COMPACT NEW IRRIGATION TRENCHES; TILL AND ADD AMENDMENTS AND FERTILIZERS PER SPECIFICATIONS, AND THEN APPLY HYDROSEED TURF MIX. SEE SPEC'S SECTION 02930.

CALGREEN SHADING REQUIREMENTS

Per CALGreen section 5.106.12, shade trees:

5.106.12.1 Surface parking areas. Shade tree plantings, minimum #10 container size or equal, shall be installed to provide shade over 50% of the parking area within 15 years.
 Calculations:
 Parking Field only approx. = 6,324 sq. ft.
 Tree shading provided approx. = 3,225 sq. ft.
 Percentage of shading provided per CALGreen = 51%

5.106.12.2 Landscape areas. Shade tree plantings, minimum #10 container size or equal, shall be installed to provide shade over 20% of the landscape area within 15 years.
 Calculations:
 Landscape only approx. = 13,869 sq. ft.
 Tree shading provided approx. = 7,092 sq. ft.
 Percentage of shading provided per CALGreen = 51%

5.106.12.3 Hardscape areas. Shade tree planting, minimum #10 container size or equal, shall be installed to provide shade over 20% of the hardscape area within 15 years.
 Calculations:
 Hardscape (patios) only approx. = 4,682 sq. ft.
 Tree shading provided approx. = 1,558 sq. ft.
 Percentage of shading provided per CALGreen = 33%

ARCHITECT STAMP	CONSULTANT STAMP

REVISIONS

NO.	DATE	DESCRIPTION
1	04-19-2022	ADDENDUM 1
2	MAY 13, 2022	ADDENDUM 4
3	MAY 20, 2022	ADDENDUM B

THE ARCHITECT DOES NOT REPRESENT THAT THESE PLANS OR THE SPECIFICATIONS ARE SUITABLE FOR ANY SITE OTHER THAN THE ONE FOR WHICH THEY WERE SPECIFICALLY PREPARED. THE ARCHITECT DISCLAIMS RESPONSIBILITY FOR THESE PLANS AND SPECIFICATIONS IF THEY ARE USED IN WHOLE OR IN PART AT ANY OTHER SITE.

PROJECT OWNER & TITLE
ORCUTT UNION SCHOOL DISTRICT
 500 Dyer Street
 Orcutt, CA 93455
ORCUTT ACADEMY HS MUR BUILDING
 610 Pinal Avenue
 Orcutt, CA 93455

SHEET TITLE
PLANTING PLAN

DRAWN BY: _____ JOB NUMBER: 20179.01
 SHEET NO.
L-101
 DATE: MAY 20, 2022

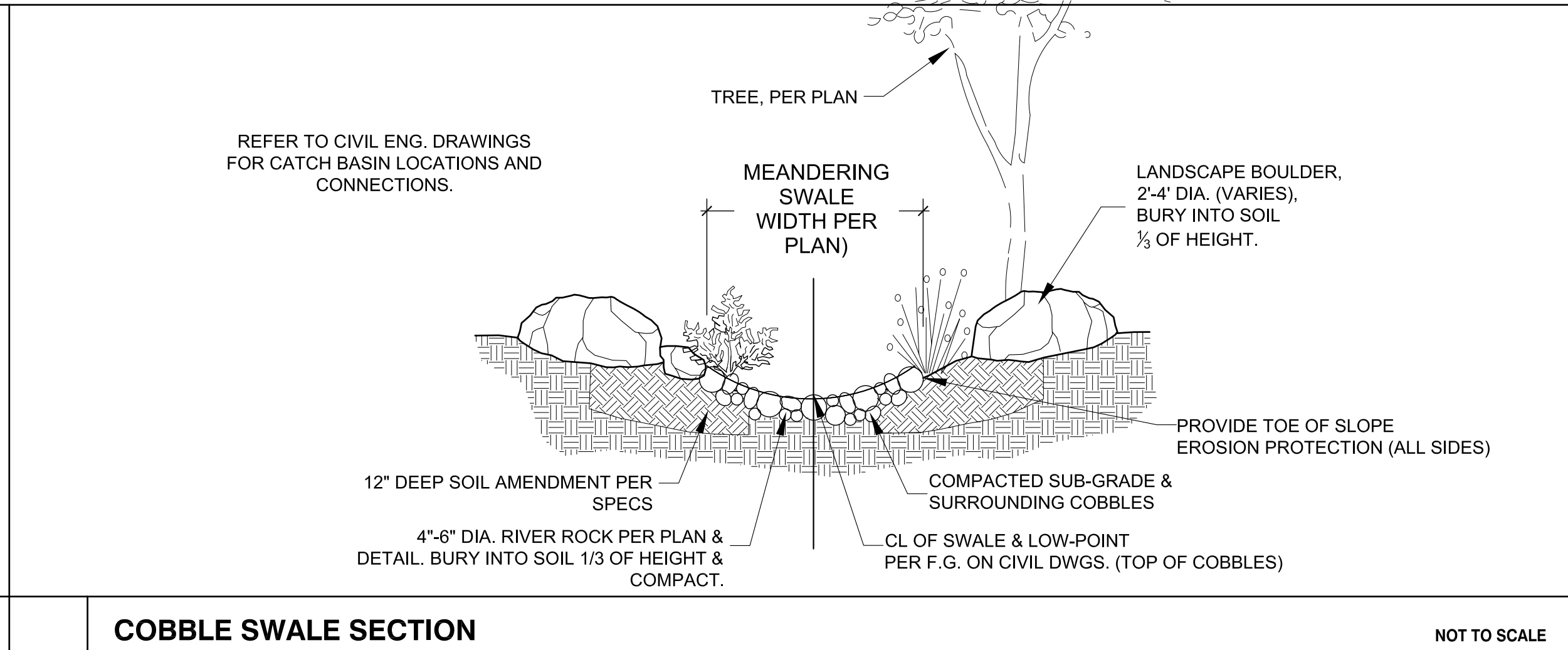
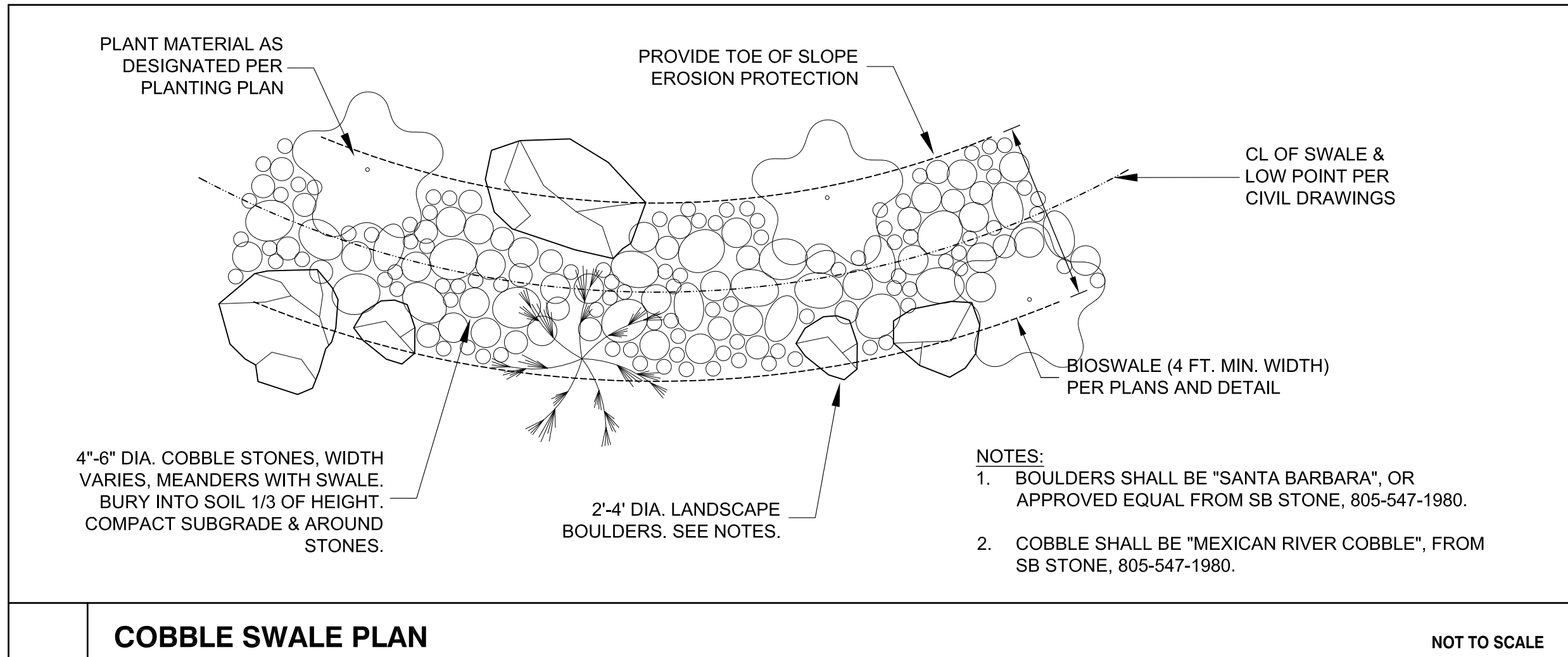
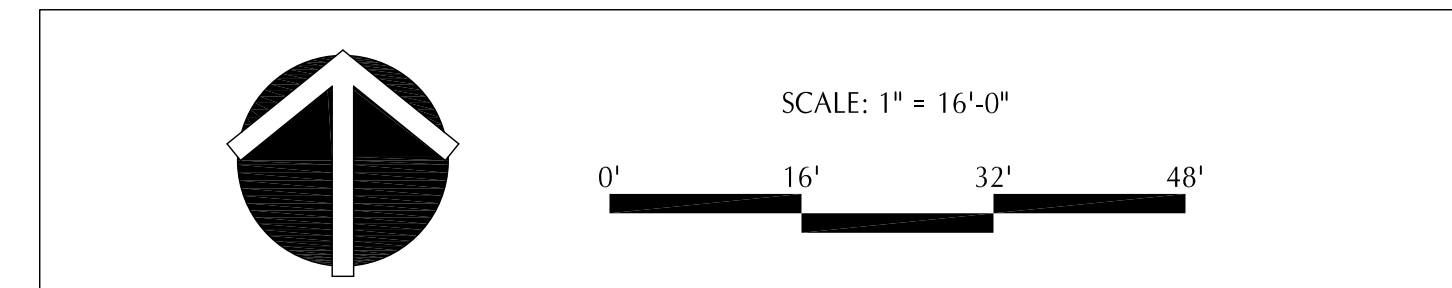

FILE LOCATION:
DATE PLOTTED:

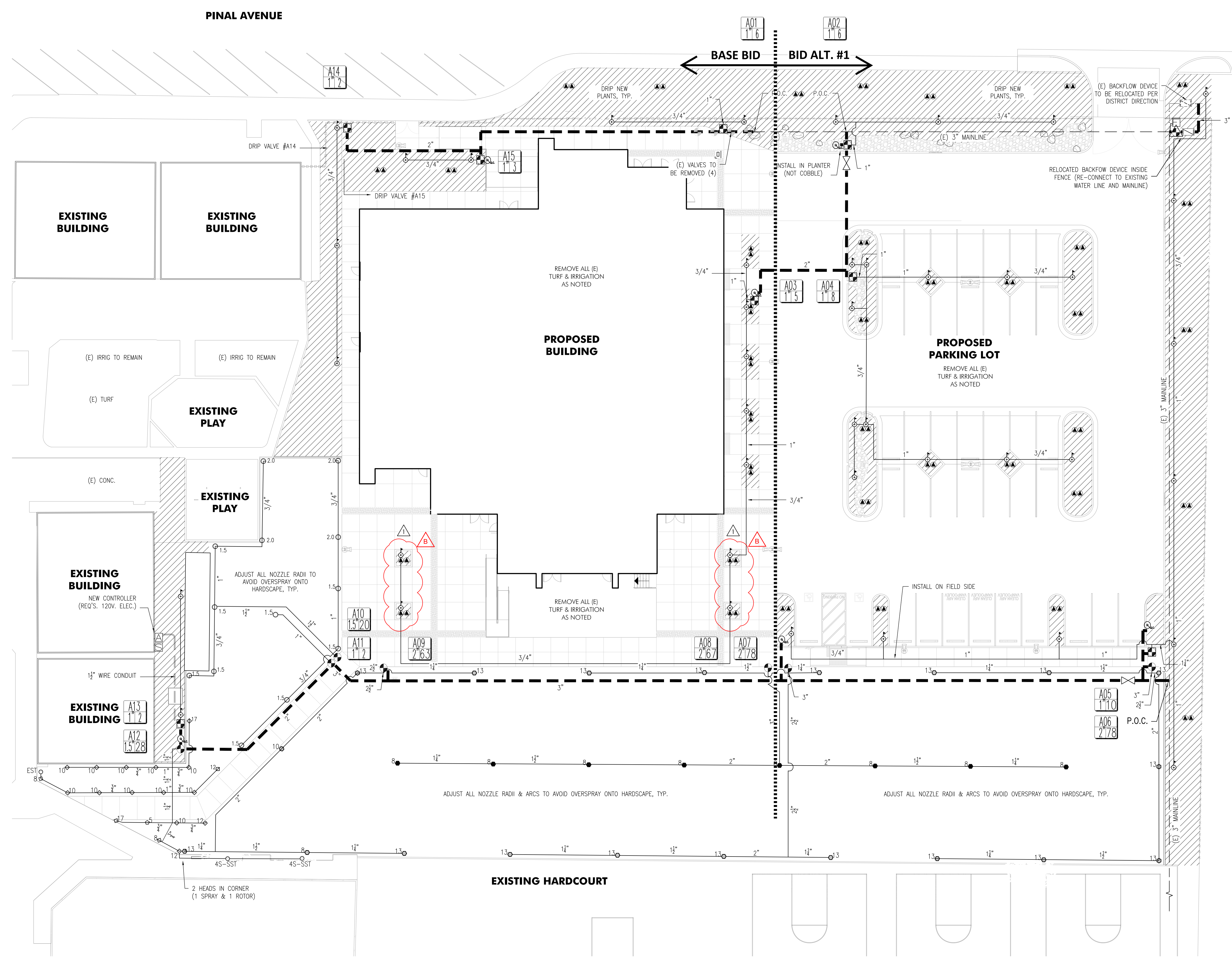

IRRIGATION LEGEND

SYMBOL	DESCRIPTION	NOTE
	IRRITROL MC-18E SERIES AUTO. CONTROLLER IN VIT ENCLOSURE (#8-1 BSS) WITH #CL-100-WIRELESS WEATHER SENSING SYSTEM	INSTALL PER LOCAL CODES AND MANUFACTURERS INSTRUCTIONS. REFER TO DETAIL 4, SHEET L-301
	IRRITROL 700-OMR100 SERIES ELECTRIC VALVE. SIZE PER VALVE KEY	REFER TO DETAIL 6, SHEET L-301
	LATERAL LINE SCH. 40 PVC PIPE SEE NOTE 'G'	REFER TO DETAIL 9, SHEET L-301
	MAINLINE SCH. 40 PVC PIPE (3" UNLESS NOTED)	REFER TO DETAIL 9, SHEET L-301
	TORO #DZK-700 DRIP CONTROL ZONE KIT	REFER TO DETAIL 12, SHEET L-301
	DRIPLINE 5/8" I.D. POLY. PIPE (TORO BLUE STRIPE) WITH TORO NGE-PC EMITTERS	SEE NOTE 'F' FOR EMITTER QNTY. SEE DETAILS 13-14, SHEET L-301
	PVC TO POLY DRIPLINE ADAPTER	REFER TO DETAIL 15, SHEET L-301
	EXISTING BACKFLOW DEVICE TO BE REPLACED & RELOCATED	INSTALL NEW RP DEVICE PER DETAIL 5, SHEET L-301
	RAINBIRD 44-LRC QUICK COUPLER VALVE	REFER TO DETAIL 7, SHEET L-301
	NDS BTU-2000-TE PVC BALL VALVE	REFER TO DETAIL 8, SHEET L-301
	EXISTING FERTILIZER INJECTOR & VALVE TO BE RELOCATED	INSTALL INSIDE NEW FENCE, BELOW GRADE (ON LEVEL SURFACE)
	SUPERIOR 3100-200 MASTER VALVE (NC) WITH IRRITROL FS-15 FLOW SENSOR (1.8-108 GPM)	REFER TO DETAILS 19 & 20, SHT. L-301

IRRIGATION HEADS

SYMBOL	DESCRIPTION	PSI	RADIUS (FT.)	FLOW (GPM)	PRECIP (IN./HR)
	TORO 5702-6P-PRK-COM POP-UP SPRAY # = TVAN NOZZLE RADIUS (8-17); INSTALL PER DETAIL 16, SHT. L-301 EST = 4x15 END STRIP, 45-SST = 4x18 SIDE STRIP, 5 = MFR NOZZLE	30	7-17	5-2.4	-1.7-4.6
	HUNTER 1-20-06-SS TURF ROTOR	45	20-30'	1.5-2.0	-24-.30
	HUNTER 1-20-06-SS TURF ROTOR # = NOZZLE RADIUS (1.5-2.0); INSTALL PER DETAIL 10, SHT. L-301	45	20-30'	1.5-2.0	-30-.46
	HUNTER 1-40-06-SS TURF ROTOR	50	30-40'	11.1	-85-.99
	HUNTER 1-40-06-SS TURF ROTOR # = NOZZLE RADIUS (13); INSTALL PER DETAIL 10, SHT. L-301	50	30-40'	11.1	-85-.99
	RAINBIRD RWS-8-PCT10-SOCK-GRATE INSTALL 2 PER TREE. INSTALL PER DETAIL 17, SHT. L-301	30	DRIP BUBBLER	.10 GPH	N.A.

VALVE KEY

	VALVE & CONTROLLER STA. #
	VALVE SIZE $\frac{1}{2}$ " 100 GALLONS PER MINUTE

- ### KEY NOTES
- REMOVE EXISTING VALVES, IRRIGATION HEADS AND LATERAL LINES LOCATED IN PROJECT AREA. RETURN VALVES AND HEADS TO DISTRICT. ABANDON LATERALS UNLESS IN CONFLICT (REMOVE).
 - COORDINATE WITH DISTRICT FOR ESTABLISHMENT PERIOD CONTROLLER SCHEDULE. CONTACT BRAD GITCHELL AT (805) 938-8971.

- ### IRRIGATION NOTES
- IRRIGATION PLANS ARE DIAGRAMMATIC. ACTUAL LINE AND HEAD PLACEMENT SHALL BE DETERMINED ON SITE DURING CONSTRUCTION. CONTRACTOR SHALL ADJUST NOZZLE RADIUS (TO ACHIEVE 100% COVERAGE) BASED ON PLAN LAYOUT & IN-FIELD DIMENSIONS.
 - POINT OF CONNECTION (P.O.C.) AT EXISTING MAINLINE BY LANDSCAPE CONTRACTOR.
 - SYSTEM DESIGN BASED ON 80 P.S.I. STATIC WATER PRESSURE. MINIMUM OPERATING PRESSURE SHALL BE 30 P.S.I. FOR DRIP, SPRAY HEADS, & BUBBLERS, AND 45-50 PSI FOR ROTARY SPRINKLERS.
 - LANDSCAPE CONTRACTOR SHALL BE RESPONSIBLE FOR 100% COVERAGE AT NO ADDITIONAL COST TO OWNER. SITE DIMENSIONS SHOULD BE THOROUGHLY CHECKED BY CONTRACTOR PRIOR TO BIDDING AND CONSTRUCTION. DISCREPANCIES SHOULD BE IMMEDIATELY BROUGHT TO THE ATTENTION OF THE LANDSCAPE ARCHITECT.
 - REFER TO THE SPECIFICATIONS PRIOR TO BIDDING AND CONSTRUCTION (DOCUMENTS ARE INCOMPLETE WITHOUT SPECIFICATIONS).
 - ALL LINES & CONTROL WIRES UNDER PAVING SHALL BE SLEEVED. CONTRACTOR SHALL INSTALL SLEEVES IN STRAIGHT LINES FROM PLANTER TO PLANTER. PLACE DESIGNATED LINE (A WIRES) INSIDE SLEEVE PRIOR TO INSTALLATION. SLEEVES SHALL BE 2x LINE SIZE.
 - PIPE SIZES SHOWN ON THE PLAN CONTINUE DOWNSTREAM, TO THE NEXT SIZE LABEL, TYPICAL.
 - IRRIGATION EQUIPMENT MAY BE SHOWN OUTSIDE OF PLANTERS FOR CLARITY. INSTALL ALL EQUIPMENT IN PLANTERS UNLESS NOTED OTHERWISE.
 - INSTALL TWO (2) 1 GPH EMITTERS PER 1 GAL. CONTAINER, 3-1 GPH/5 GAL., 2-2 GPH/15 GAL., 3-2 GPH/24" BOX. INSTALL EMITTERS AT EQUAL DISTANCE AROUND ROOTBALL.



560 HIGUERA STREET, SUITE C
SAN LUIS OBISPO, CA 93401
TEL (805) 476-0399

CONSULTANTS
CIVIL ENGINEER
STANTEC CONSULTING SERVICES INC.
111 East Victoria Street
Santa Barbara, CA 93101
TEL (805) 680-6830

LANDSCAPE ARCHITECT
OASIS ASSOCIATES
3427 Miguellto Court
San Luis Obispo, CA 93401
TEL (805) 541-4509

STRUCTURAL ENGINEER
STORCK WOLFE & ASSOCIATES
555 Chorro Street, Suite A1
San Luis Obispo, CA 93405
TEL (805) 548-8600

MECHANICAL ENGINEER
BMA MECHANICAL +
100 Cross Street, Suite
204
San Luis Obispo, CA 93401
TEL (805) 544-4269

ELECTRICAL ENGINEER
THOMA ENGINEERING
3562 Empleo, Suite C
San Luis Obispo, CA
93406
TEL (805) 543-3850

FIRE PROTECTION ENGINEER
BMA MECHANICAL +
100 Cross Street, Suite
204
San Luis Obispo, CA 93401
TEL (805) 544-4269



ARCHITECT STAMP 	CONSULTANT STAMP
---------------------	----------------------

REVISIONS

NO.	DATE	DESCRIPTION
A	04/19/2022	ADDENDUM 1
B	MAY 20, 2022	ADDENDUM B

THE ARCHITECT DOES NOT REPRESENT THAT THESE PLANS OR THE SPECIFICATIONS ARE SUITABLE FOR ANY SITE OTHER THAN THE ONE FOR WHICH THEY WERE SPECIFICALLY PREPARED. THE ARCHITECT DISCLAIMS RESPONSIBILITY FOR THESE PLANS AND SPECIFICATIONS IF THEY ARE USED IN WHOLE OR IN PART AT ANY OTHER SITE.

PROJECT OWNER & TITLE
**ORCUTT UNION
SCHOOL DISTRICT**
500 Dyer Street
Orcutt, CA 93455
**ORCUTT
ACADEMY
HS MUR BUILDING**
610 Pinal Avenue
Orcutt, CA 93455

SHEET TITLE
IRRIGATION PLAN

DRAWN BY: JOB NUMBER: 20179.01
SHEET NO.

L-201
DATE: MAY 20, 2022



FILE LOCATION:
DATE PLOTTED:

FILE LOCATION: C:\Users\HCruz\Documents\20179_01_OUSD_OAHS_MUR_A20_V2_hcnz\PB9K.rvt
 DATE PLOTTED: 5/19/2022 2:06:19 PM

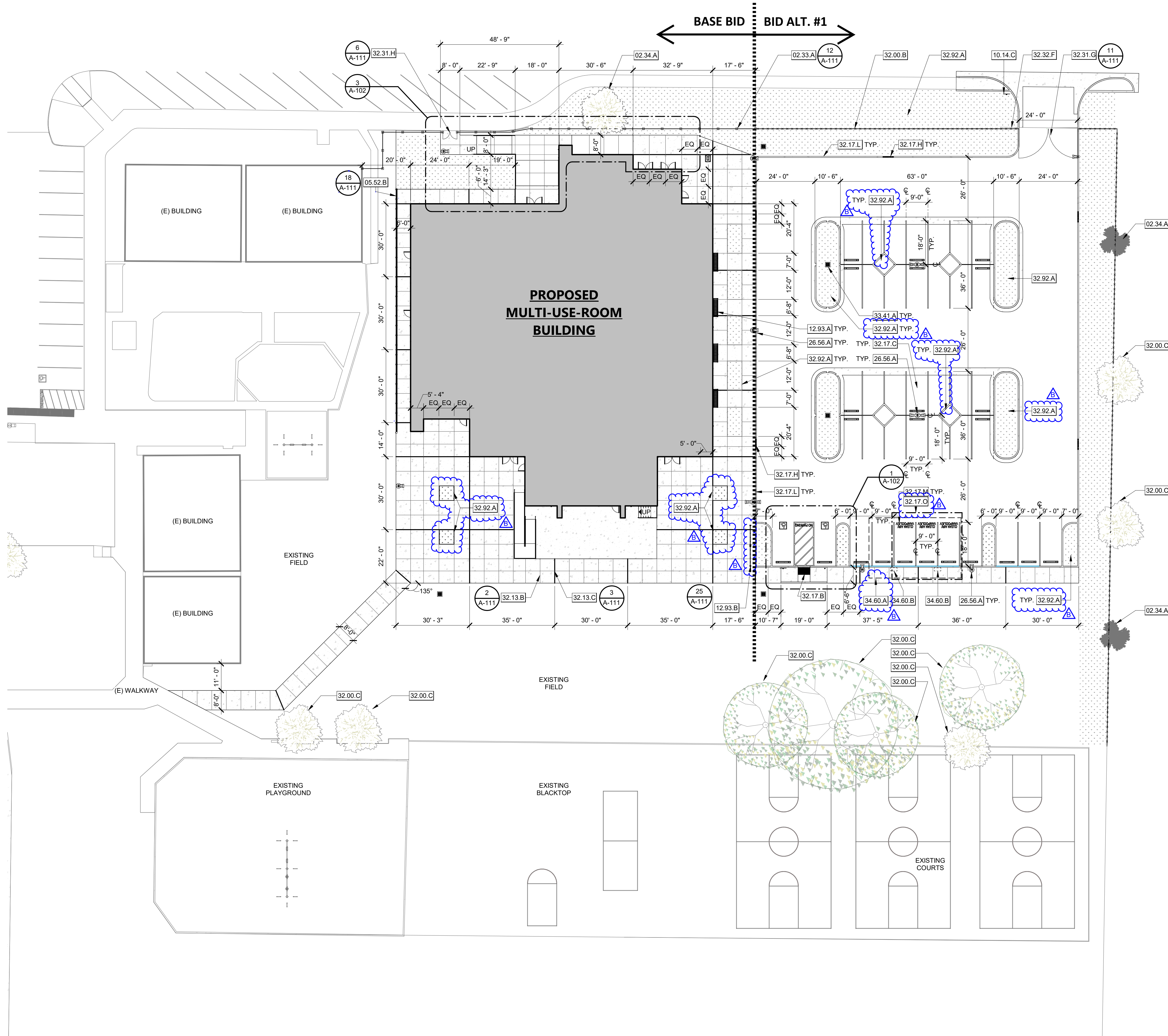

OVERALL SITE PLAN 1" = 20'-0" 1

- KEYNOTES**
- 02.33.A EXISTING CHAIN LINK FENCE TO BE REPLACED WITH DECORATIVE FENCE
 - 02.34.A EXISTING TREE TO BE REMOVED
 - 10.14.C PARKING LOT ENTRANCE SIGN PER 20A/111
 - 12.93.A SITE SEATING AND TABLES
 - 12.93.B BIKE RACK
 - 26.56.A LIGHT STANDARDS PER ELECTRICAL DRAWINGS.
 - 32.00.B (E) CHAIN LINK FENCE TO REMAIN
 - 32.00.C (E) TREE
 - 32.13.B CONTROL JOINTS AT 6'-0" O.C. OR AS SHOWN ON THE PLANS
 - 32.13.C EXPANSION JOINTS AT 30'-0" O.C. OR AS SHOWN ON THE PLANS
 - 32.17.B 36" WIDE TRUNCATED DOMES BAND
 - 32.17.C 4" WIDE WHITE STRIPING
 - 32.17.H 4" TALL HIGHWAY WHITE LETTERING WITH A STROKE OF .75" MIN. TO READ "NO PARKING - FIRE LANE" AT 100 O.C.
 - 32.17.L PAINT CURB RED
 - 32.17.M 12" "CLEAN AIR/MANPOOL/VEV", PAINT, IN THE PAINT USED FOR STALL STRIPING, SUCH THAT THE LOWER EDGE OF THE LAST WORD ALIGNS WITH THE END OF THE STALL STRIPING.
 - 32.17.O DESIGNATED PARKING FOR CLEAN AIR VEHICLES
 - 32.31.G 24'-0" WIDE DOUBLE CHAIN LINK GATE
 - 32.31.H 6'-0" TALL DOUBLE 8'-0" WIDE DECORATIVE GATE
 - 32.32.F KNOX BOX
 - 32.92.A LANDSCAPE AREA. REFER TO LANDSCAPE DRAWINGS
 - 33.41.A STORM DRAIN INLET GRATE & BOX. REFER TO CIVIL
 - 34.60.A FUTURE EV CHARGING STATIONS.
 - 34.60.B FUTURE EV CHARGER.

- SITE PLAN GENERAL NOTES**
- SEE MECHANICAL, ELECTRICAL, AND CIVIL DRAWINGS FOR UTILITIES.

FUTURE EV CHARGING STATIONS ANALYSIS*

TOTAL NUMBER OF STALLS	NUMBER OF FUTURE EV CHARGING SPACES REQUIRED	NUMBER OF FUTURE EV CHARGING SPACES PROVIDED
39	4	4

*PER CALGREEN TABLE 5.106.5.3.3

AGENCY APPROVAL **DS&J** 03-121912

560 HIGUERA STREET, SUITE C
 SAN LUIS OBISPO, CA 93401
 TEL (805) 476-0399

- CONSULTANTS**
- CIVIL ENGINEER**
 STANTEC CONSULTING SERVICES INC.
 111 East Victoria Street
 Santa Barbara, CA 93101
 TEL (805) 680-6830
 - LANDSCAPE ARCHITECT**
 OASIS ASSOCIATES
 3427 Miguelito Court
 San Luis Obispo, CA 93401
 TEL (805) 541-4509
 - STRUCTURAL ENGINEER**
 STORK, WOLFE & ASSOCIATES
 555 Chorro Street, Suite A1
 San Luis Obispo, CA 93405
 TEL (805) 548-8500
 - MECHANICAL ENGINEER**
 BMA MECHANICAL +
 100 Cross Street, Suite 204
 San Luis Obispo, CA 93401
 TEL (805) 544-4269
 - ELECTRICAL ENGINEER**
 THOMA ENGINEERING
 3562 Empleo, Suite C
 San Luis Obispo, CA 93406
 TEL (805) 543-3850
 - FIRE PROTECTION ENGINEER**
 BMA MECHANICAL +
 100 Cross Street, Suite 204
 San Luis Obispo, CA 93401
 TEL (805) 544-42-69

ARCHITECT STAMP

CONSULTANT STAMP

REVISIONS

NO.	DATE	DESCRIPTION
A	04-19-2022	ADDENDUM 1
B	05-20-2022	ADDENDUM B

THE ARCHITECT DOES NOT REPRESENT THAT THESE PLANS OR THE SPECIFICATIONS ARE SUITABLE FOR ANY SITE OTHER THAN THE ONE FOR WHICH THEY WERE SPECIFICALLY PREPARED. THE ARCHITECT DISCLAIMS RESPONSIBILITY FOR THESE PLANS AND SPECIFICATIONS IF THEY ARE USED IN WHOLE OR IN PART AT ANY OTHER SITE.

PROJECT OWNER & TITLE
ORCUTT UNION SCHOOL DISTRICT
 500 Dyer Street
 Orcutt, CA 93455

ORCUTT ACADEMY HS MUR BUILDING
 610 Pinal Avenue
 Orcutt, CA 93455

SHEET TITLE
SITE PLAN

DRAWN BY: FC, HC JOB NUMBER: 20179.01
 SHEET NO.
A-101
 DATE: MAY 10, 2022

DATE PLOTTED: 5/20/2022 11:55:25 AM FILE LOCATION: C:\Users\HCruz\Documents\20179.01_OUSD_OAHS_MUR_A20_V2_Construction\Report_hcnuz\FB9K.rvt

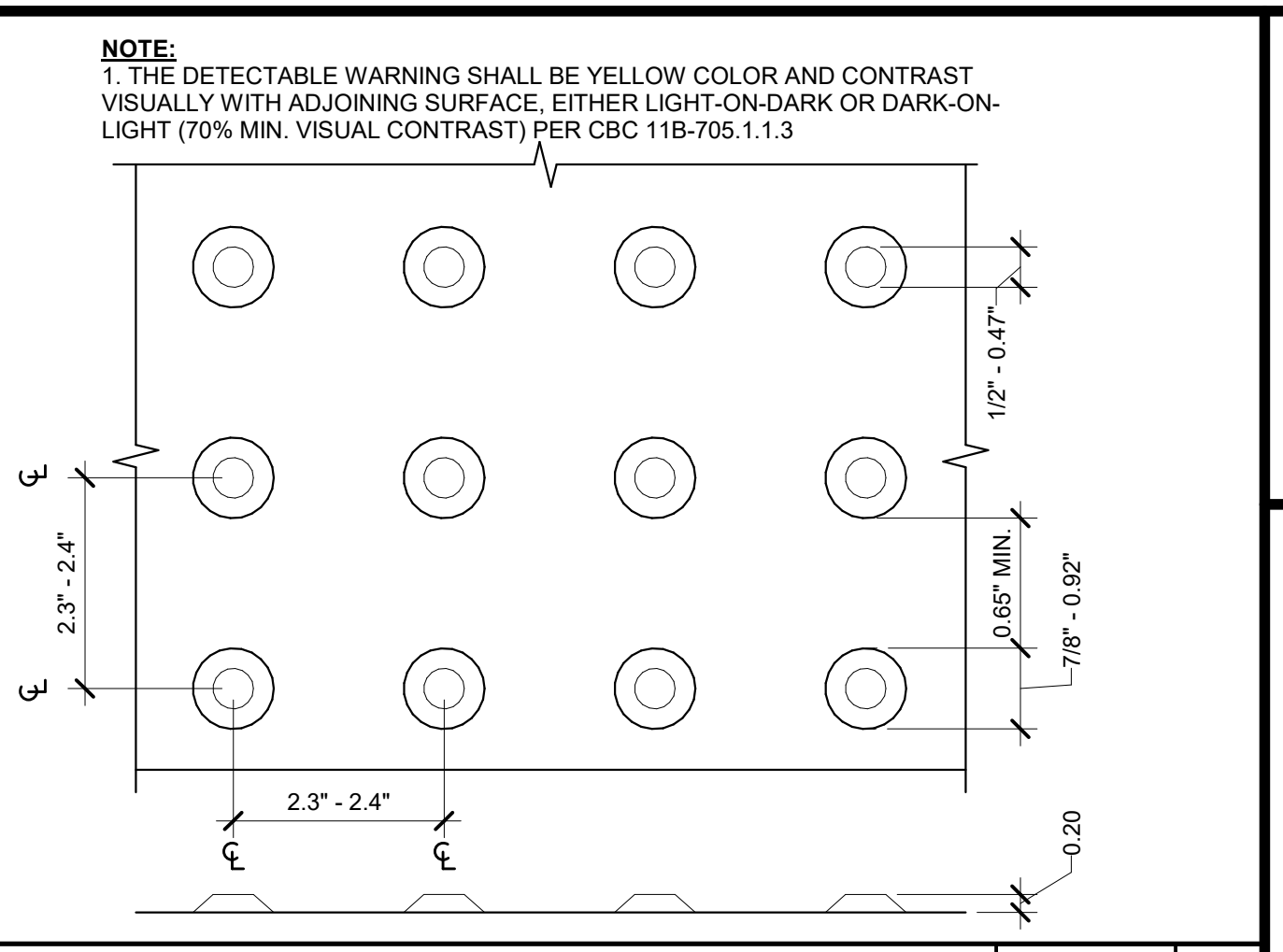
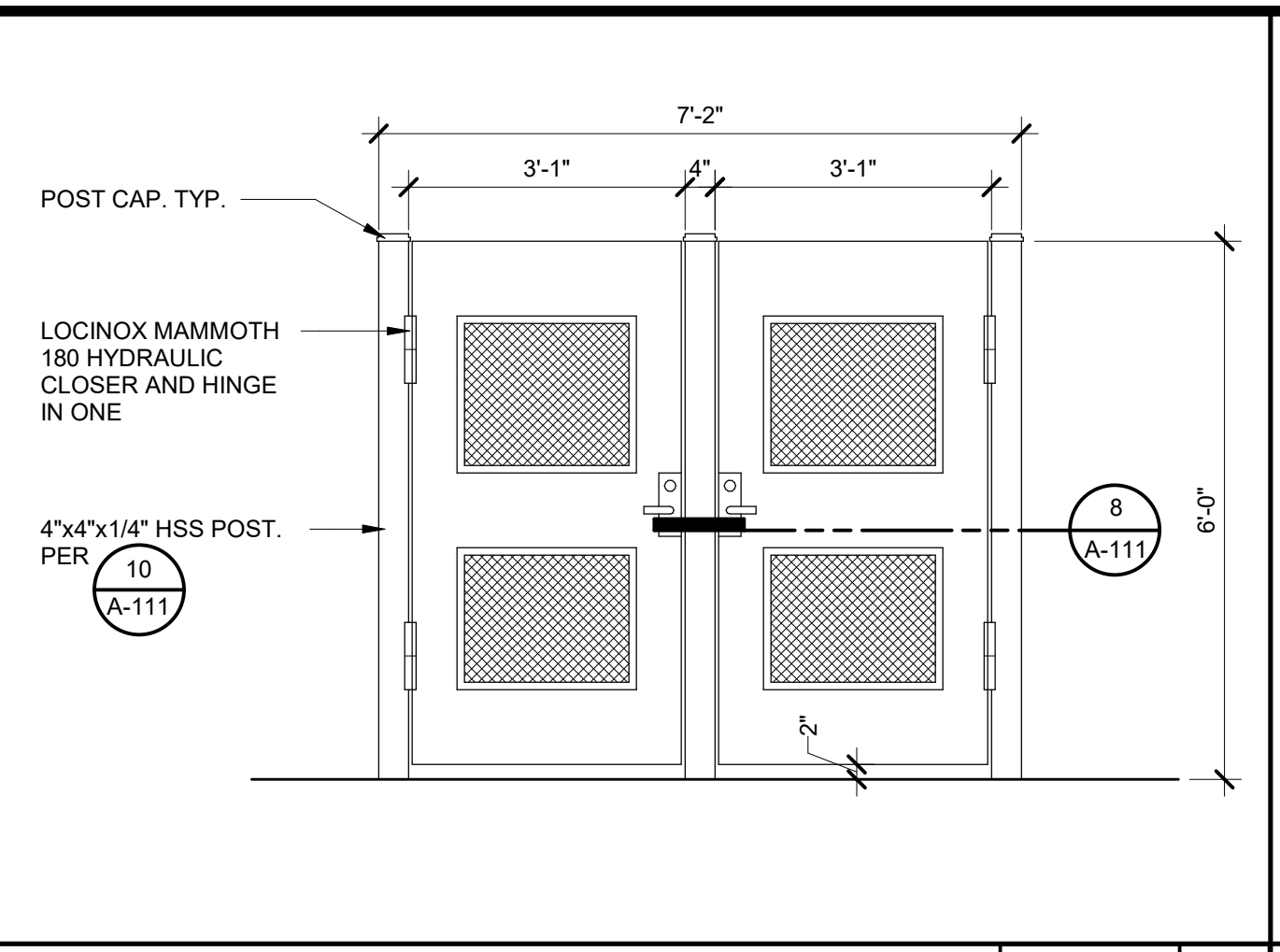
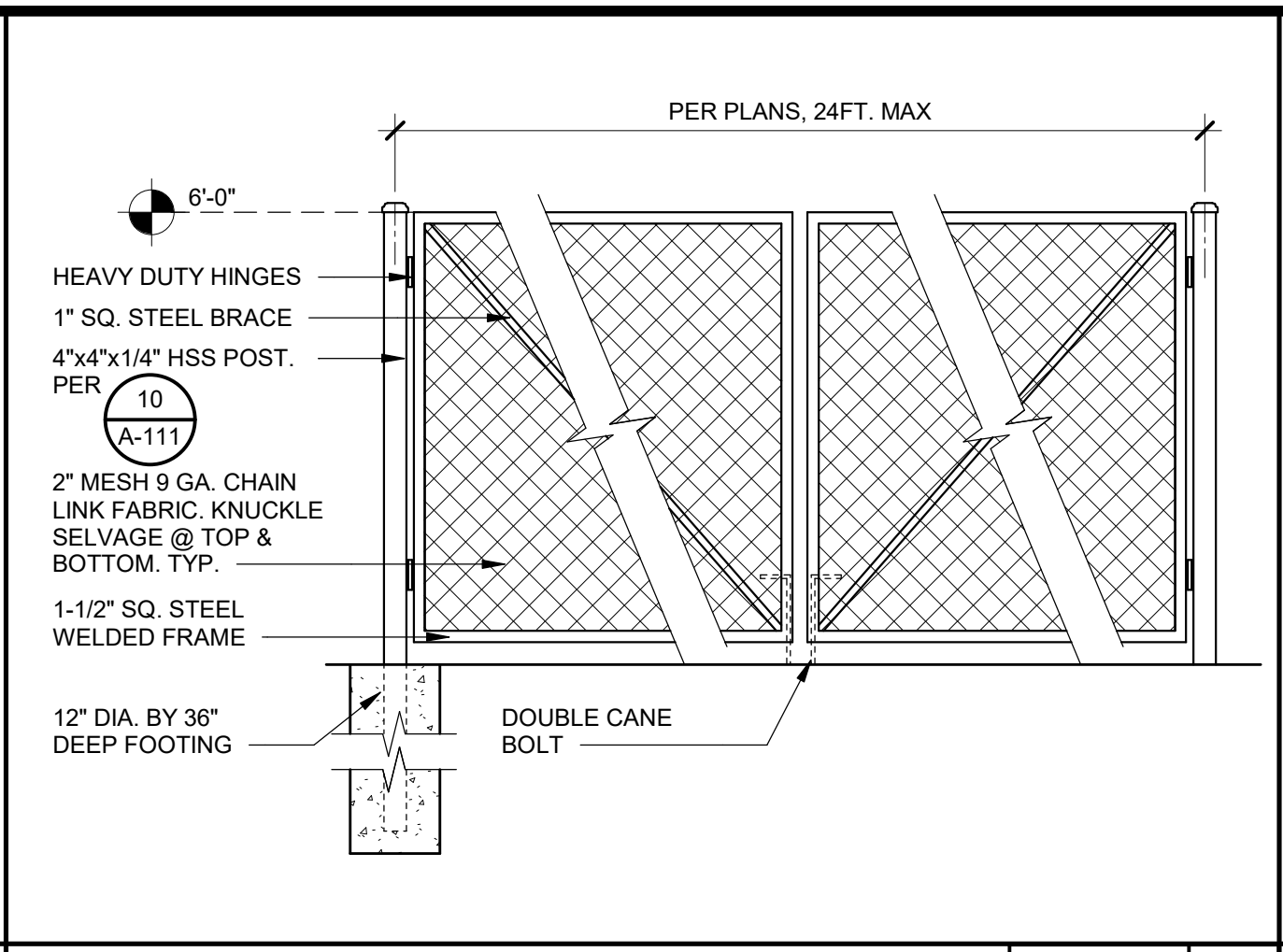

24' CHAIN LINK GATE 1/2" = 1'-0" **11**

DOUBLE DECORATIVE GATE 1/2" = 1'-0" **6**

TRUNCATED DOMES 6" = 1'-0" **1**

DECORATIVE FENCE 1/2" = 1'-0" **12**

DECORATIVE GATE 1/2" = 1'-0" **7**

CONCRETE CONTROL JOINT 1 1/2" = 1'-0" **2**

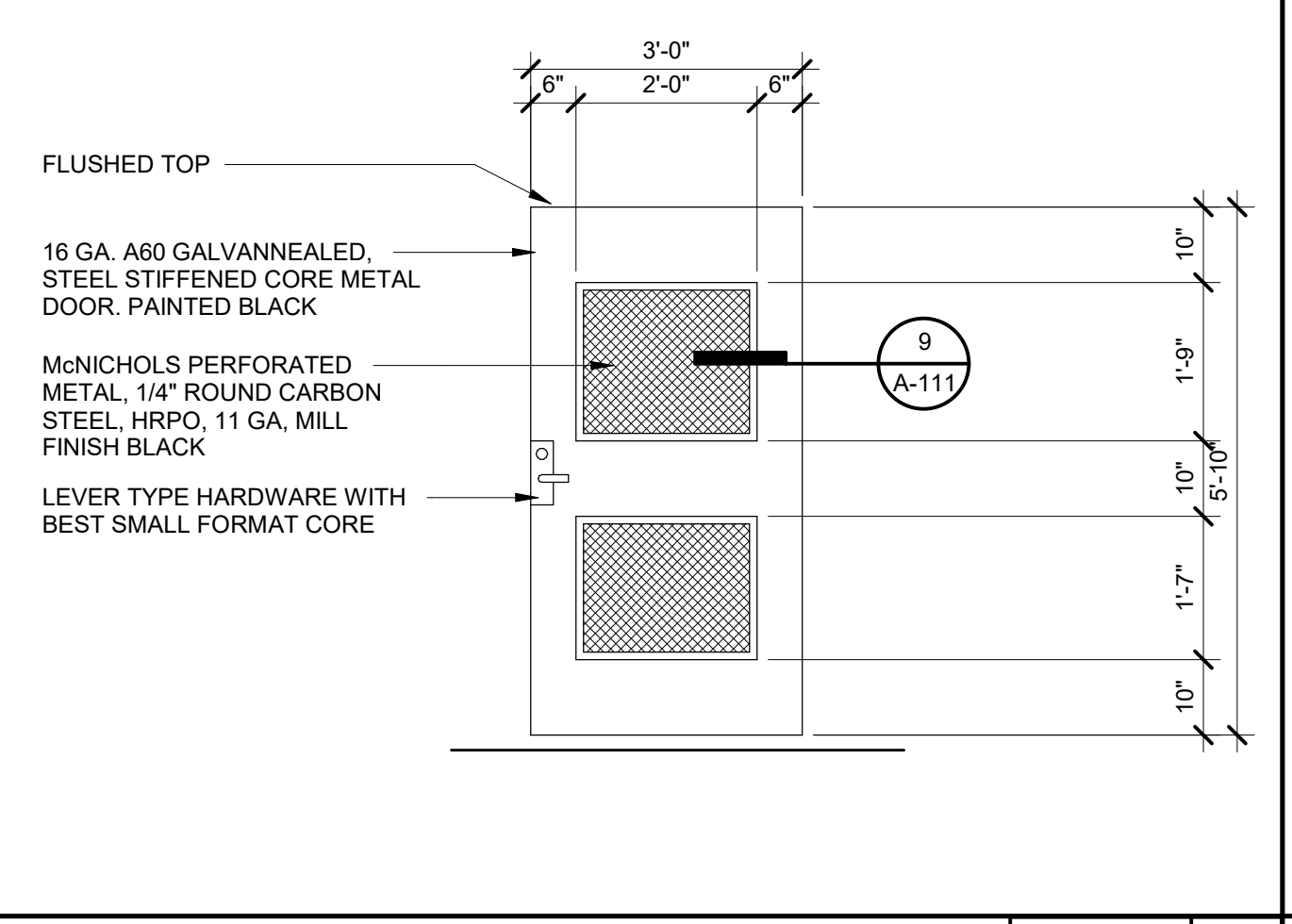
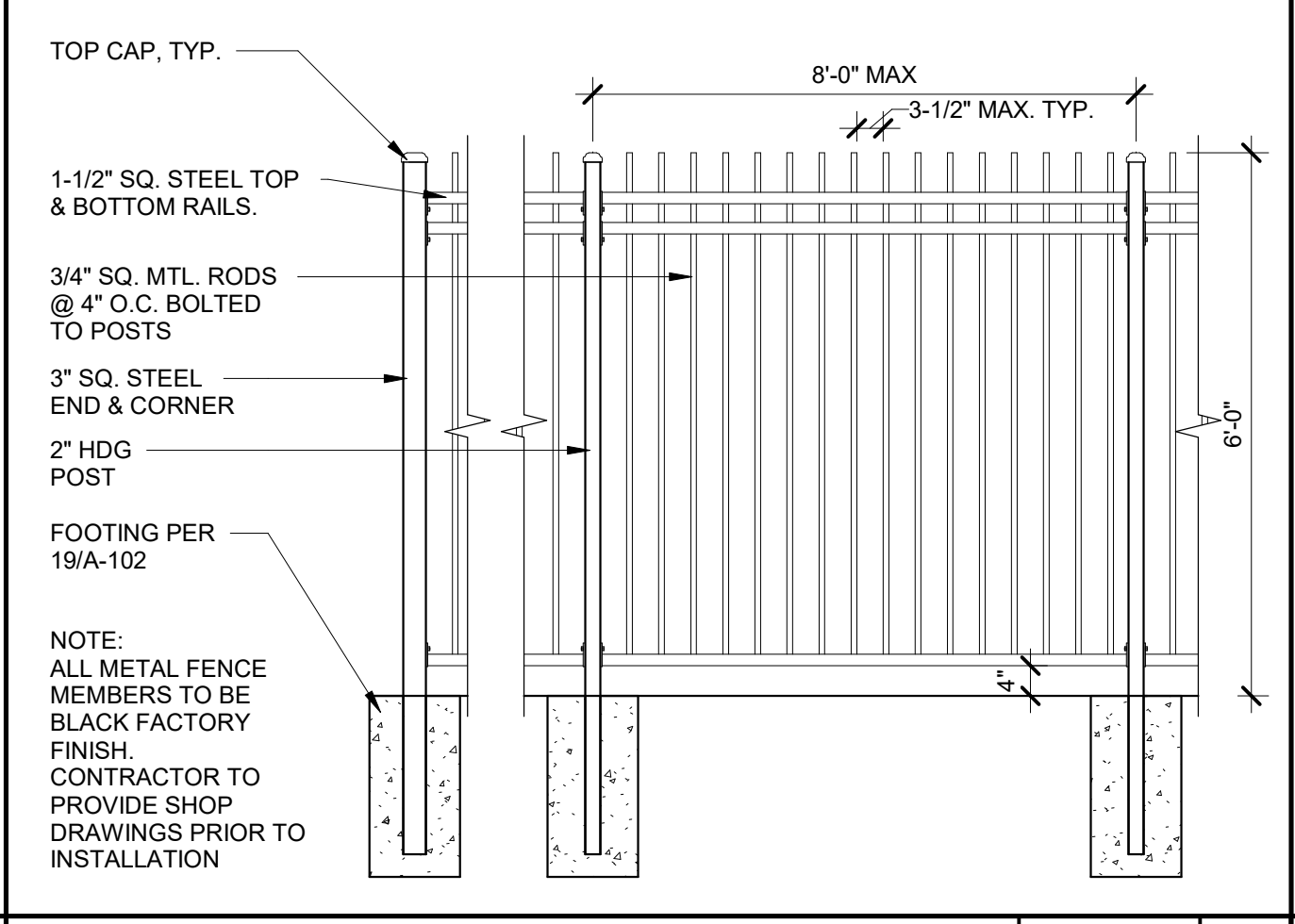
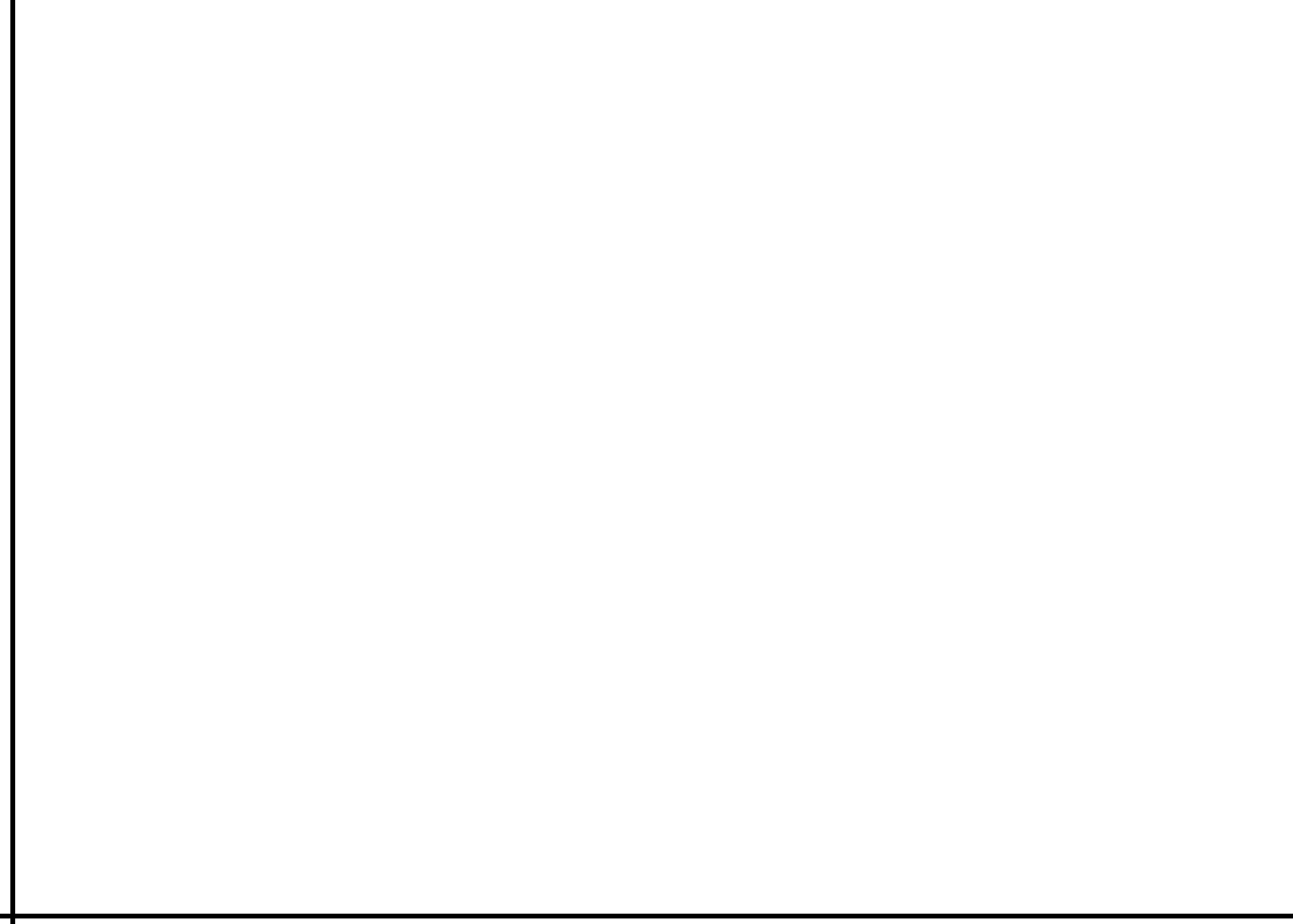

GUARDRAIL 1/2" = 1'-0" **18**

HANDRAIL AT RAMP 3/4" = 1'-0" **13**

LATCH SECTION 3" = 1'-0" **8**

CONCRETE EXPANSION JOINT 1 1/2" = 1'-0" **3**

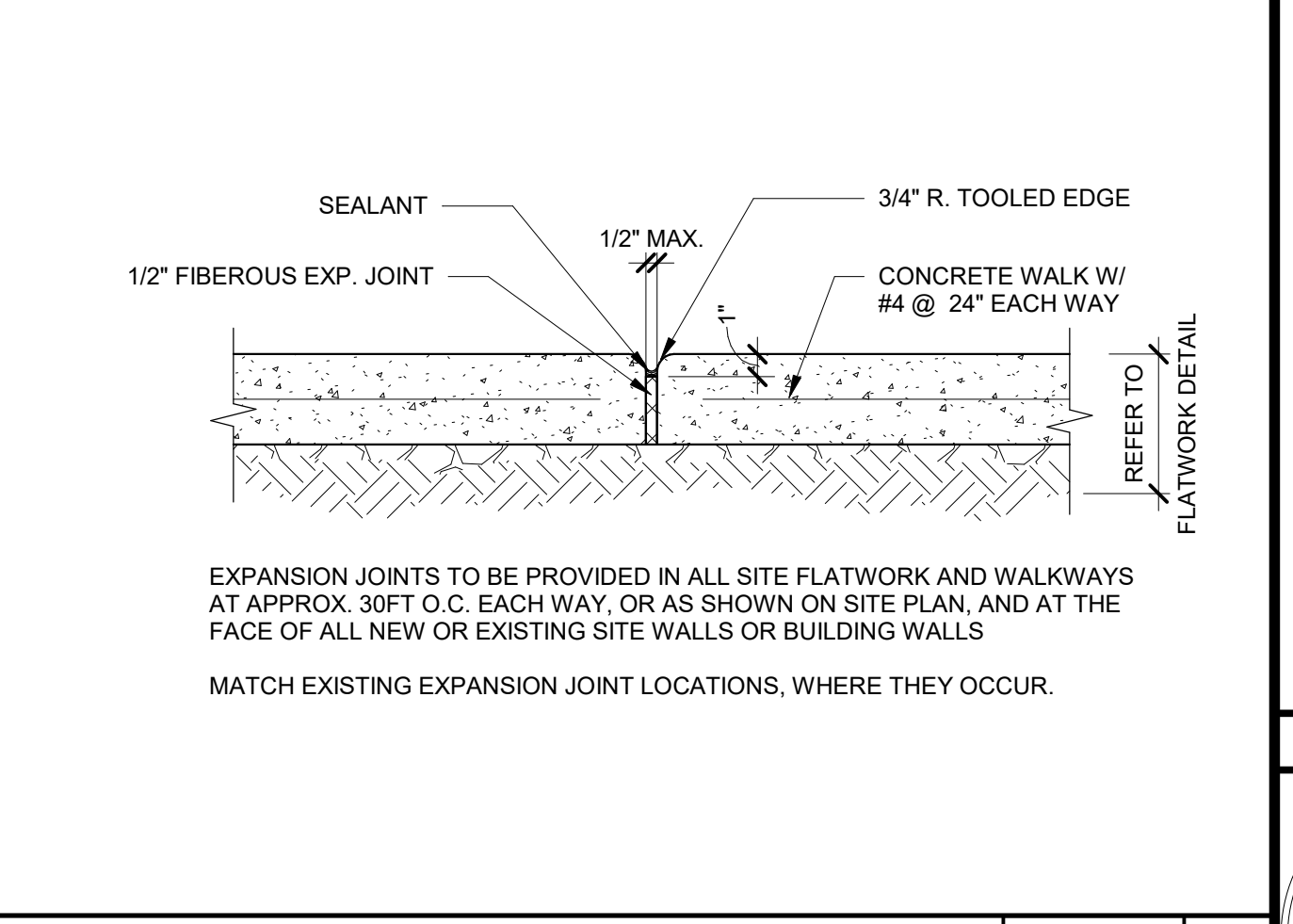
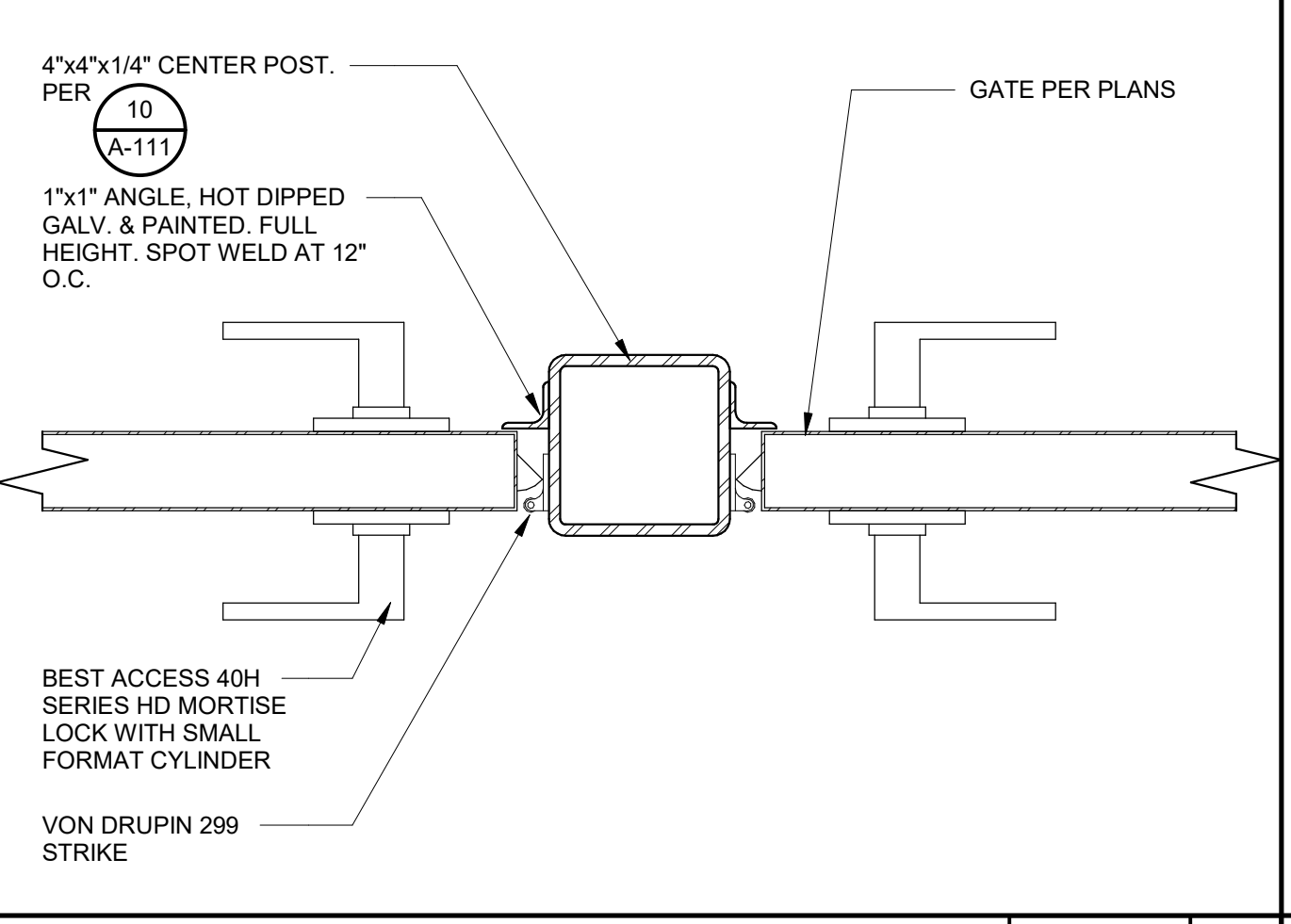
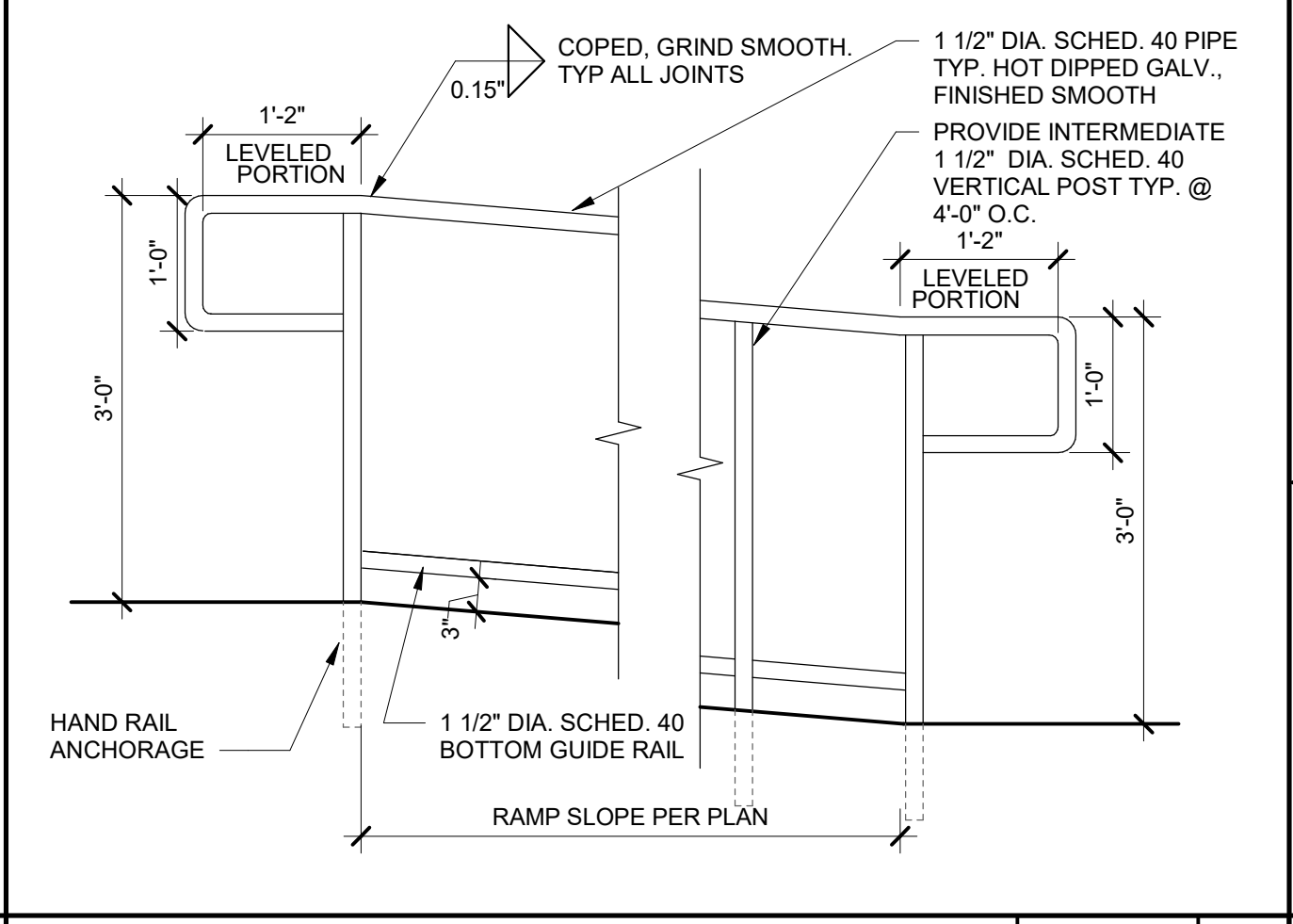
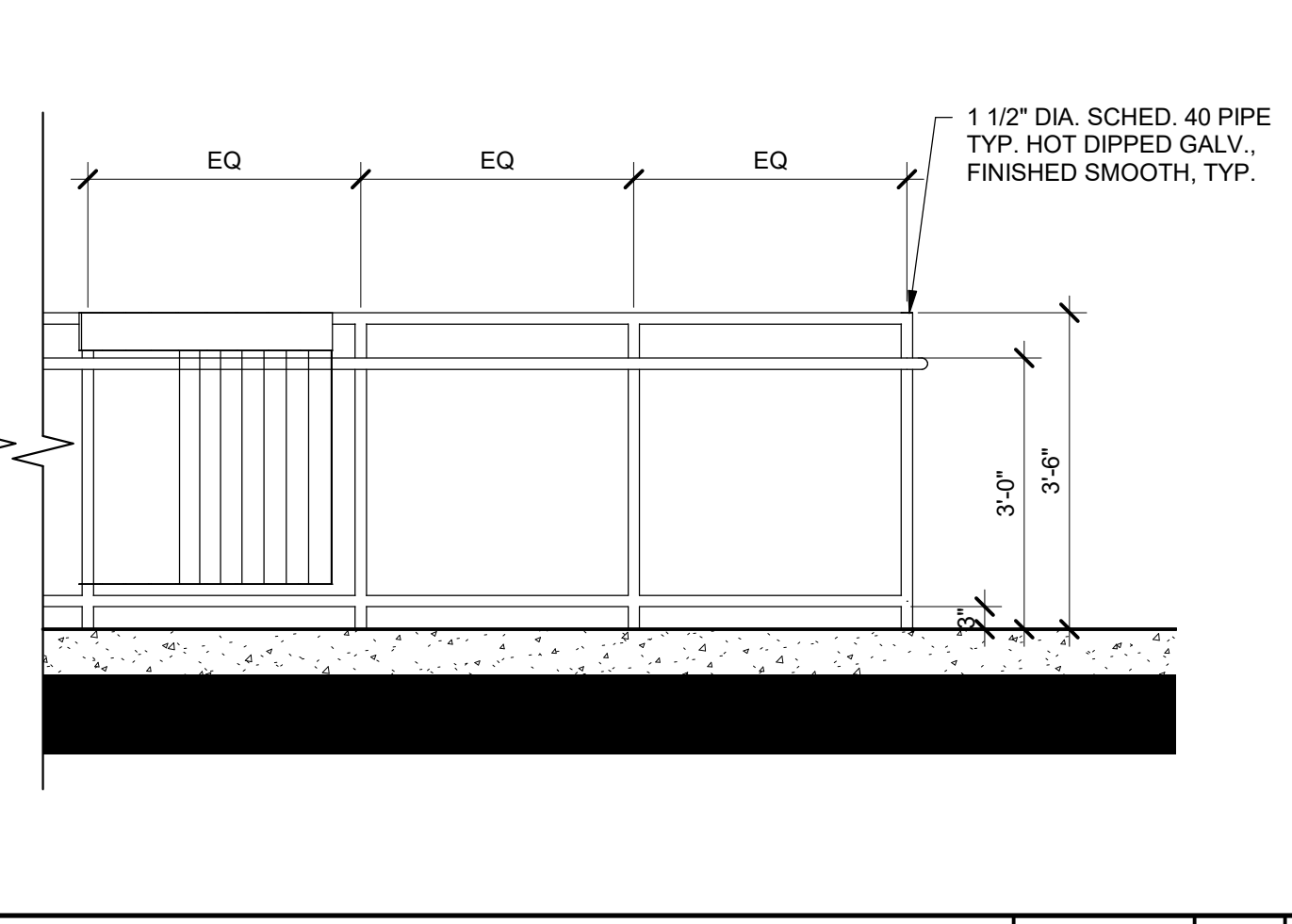
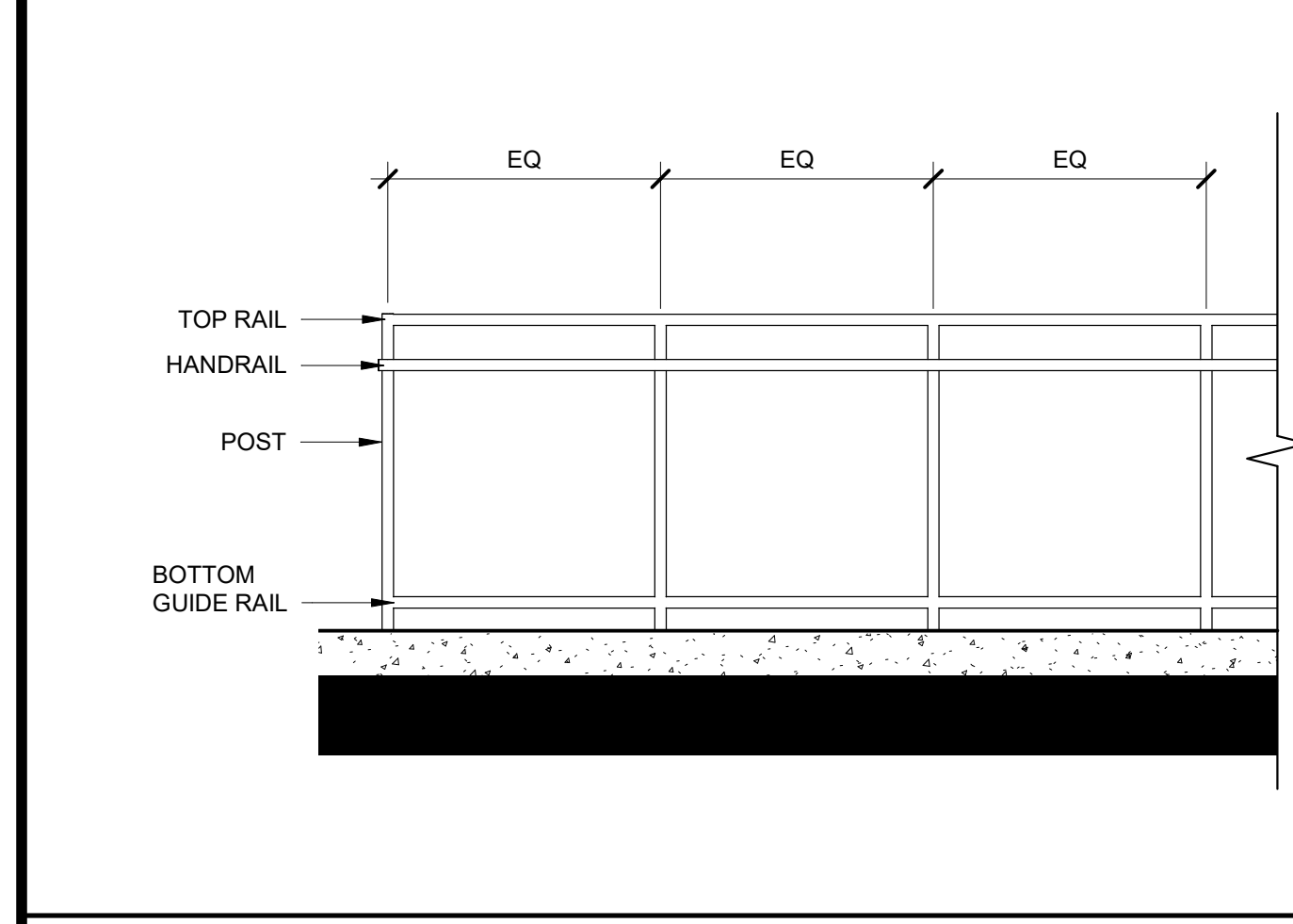

BIKE RACK ANCHORAGE 1 1/2" = 1'-0" **25**

PARKING LOT SIGNAGE 1 1/2" = 1'-0" **20**

ACC. PARKING LOT SIGNAGE 1 1/2" = 1'-0" **15**

PERFORATED PANEL AT GATE 6" = 1'-0" **9**

PRE-CAST CONC. WHEEL STOP 1 1/2" = 1'-0" **4**

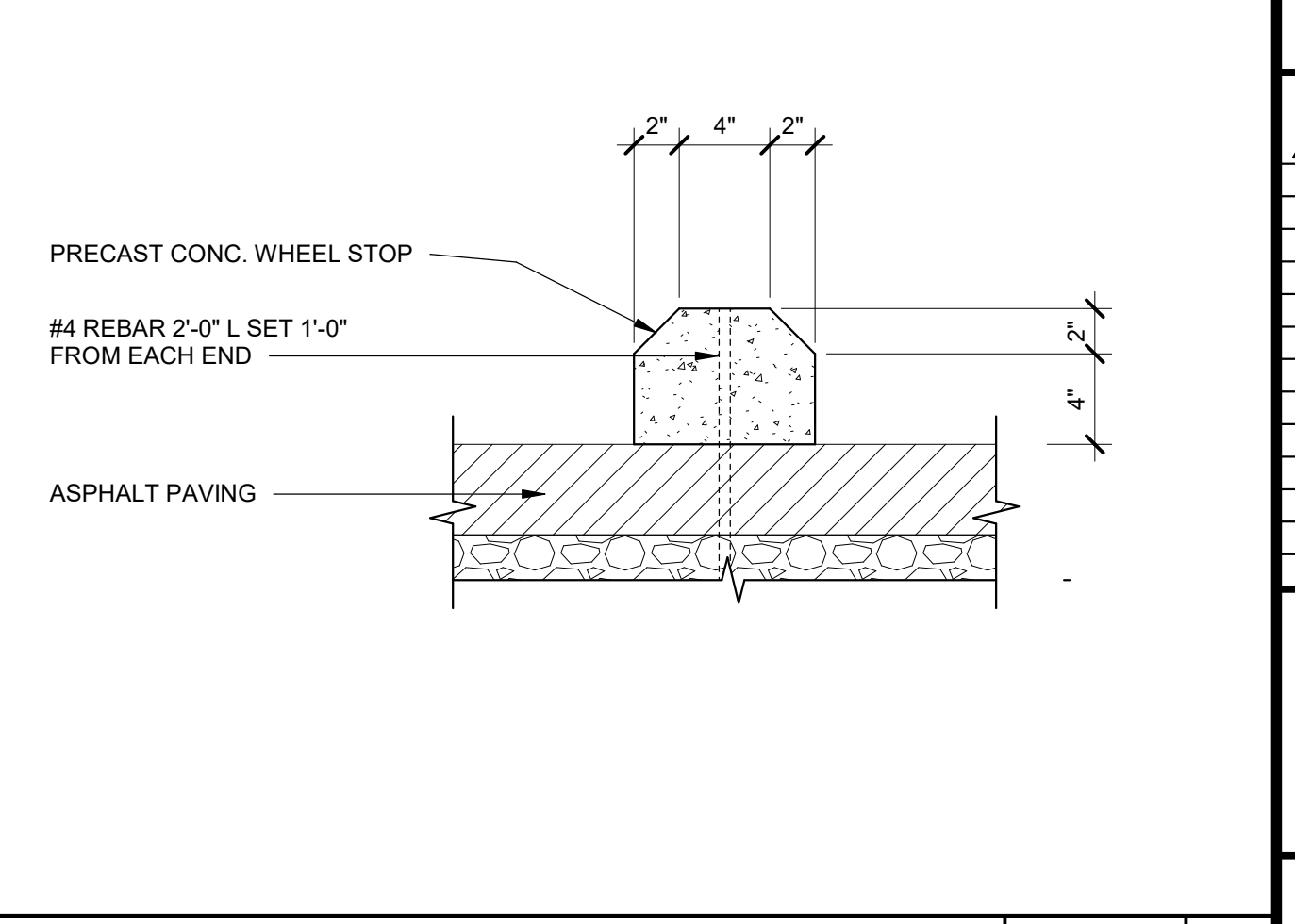
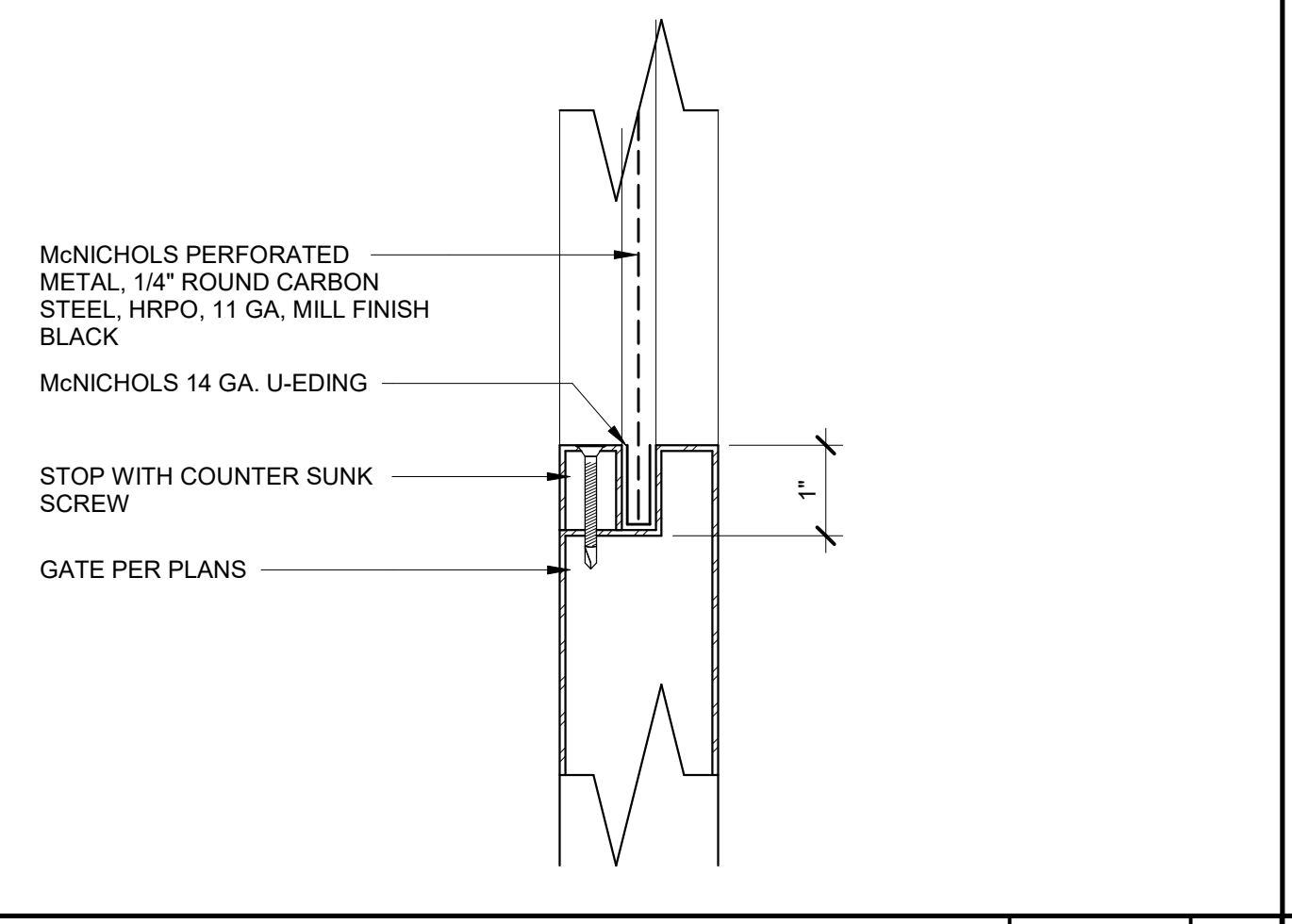
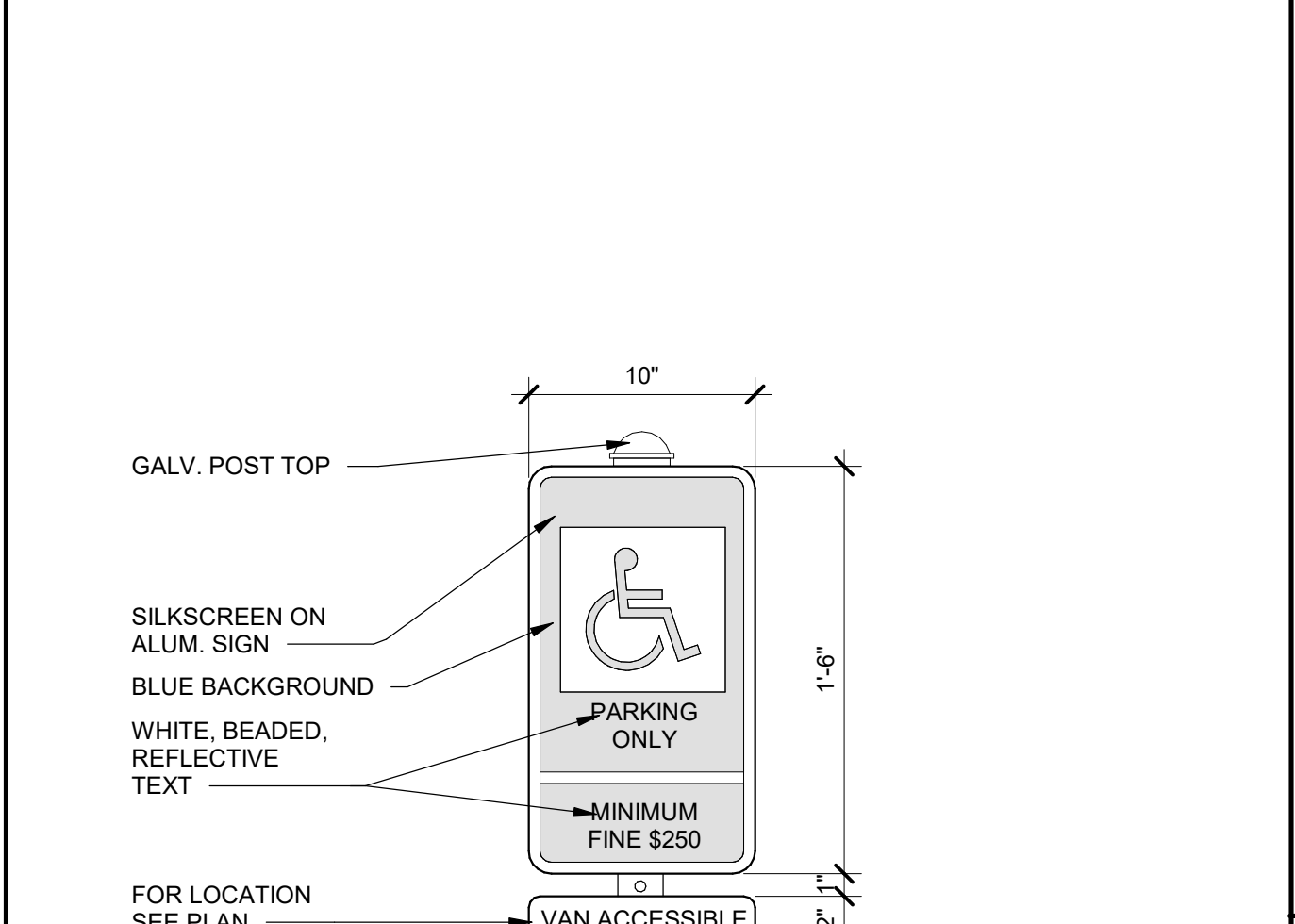
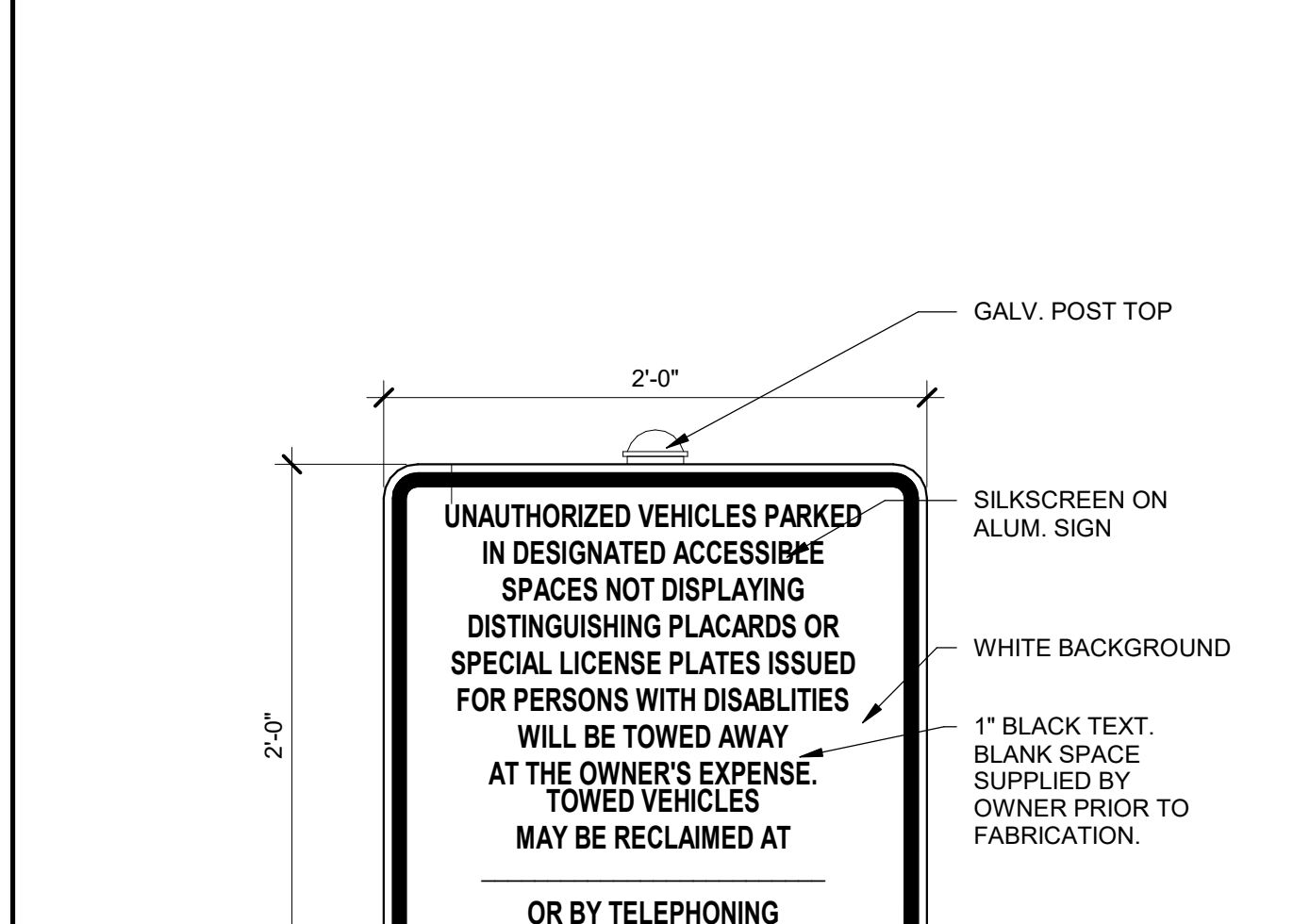

DECORATIVE GATE FOOTING 1" = 1'-0" **10**

PARKING ACESIBILITY 1" = 1'-0" **5**

PERFORATED PANEL AT GATE 6" = 1'-0" **9**

PERFORATED PANEL AT GATE 6" = 1'-0" **9**

PERFORATED PANEL AT GATE 6" = 1'-0" **9**

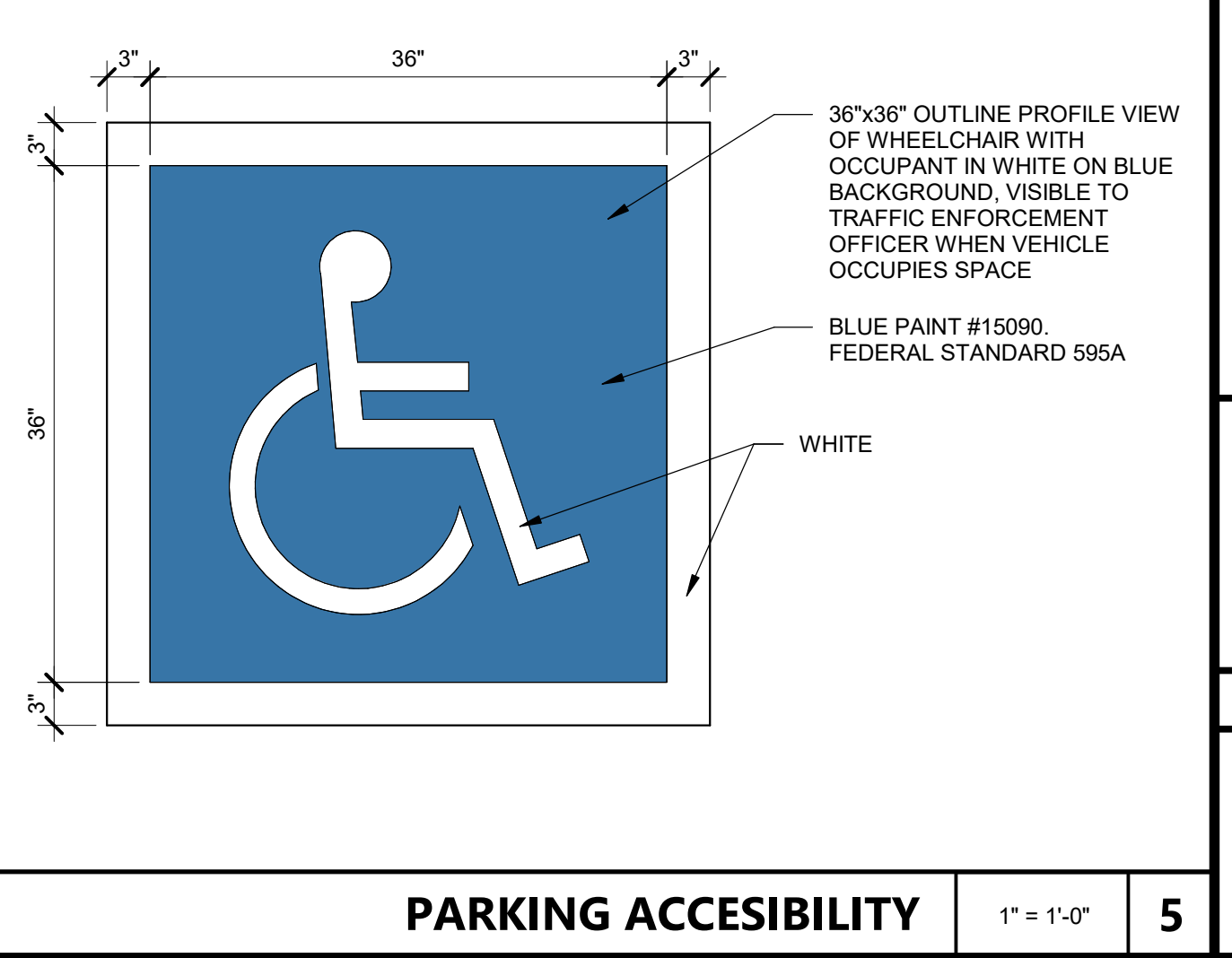
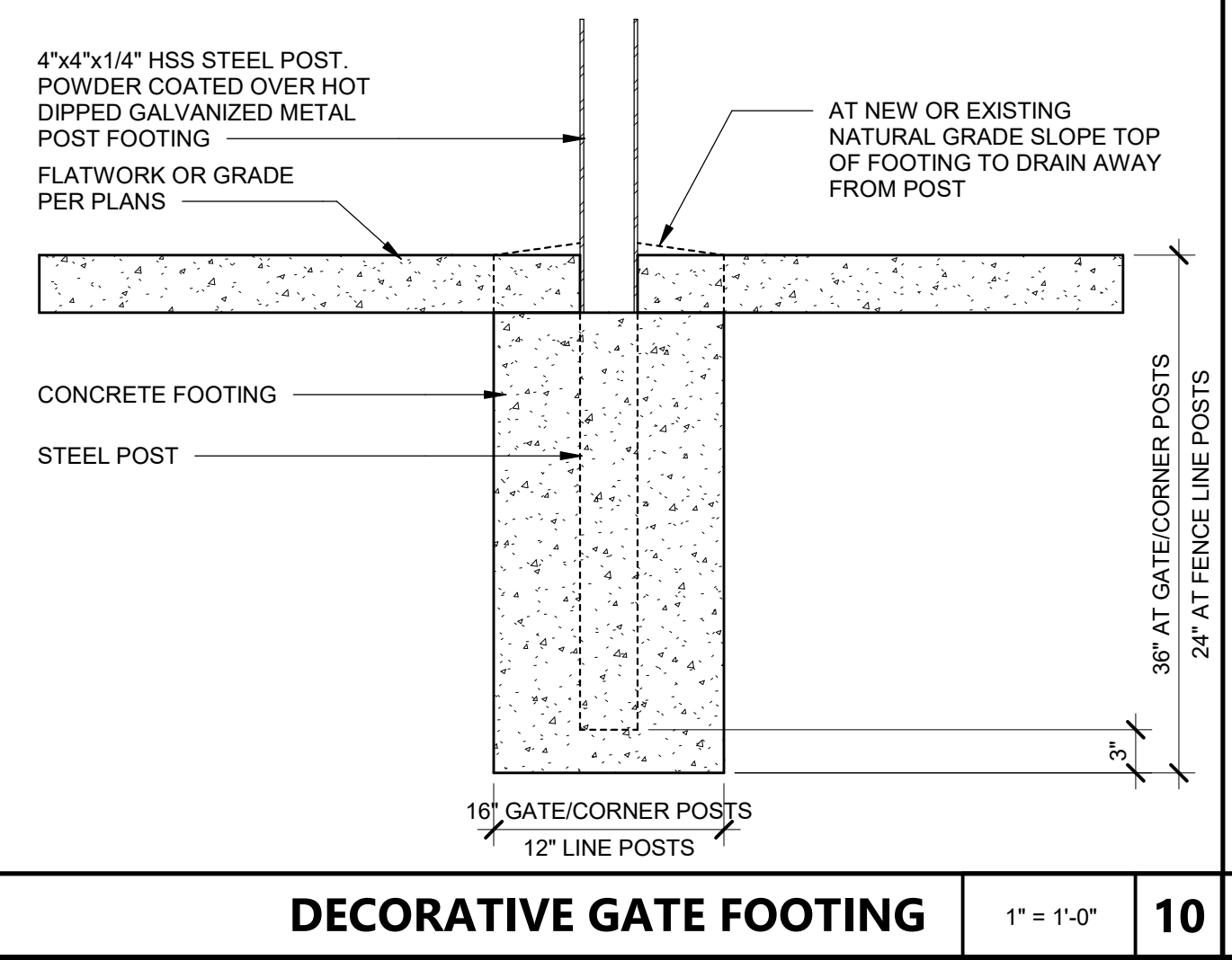
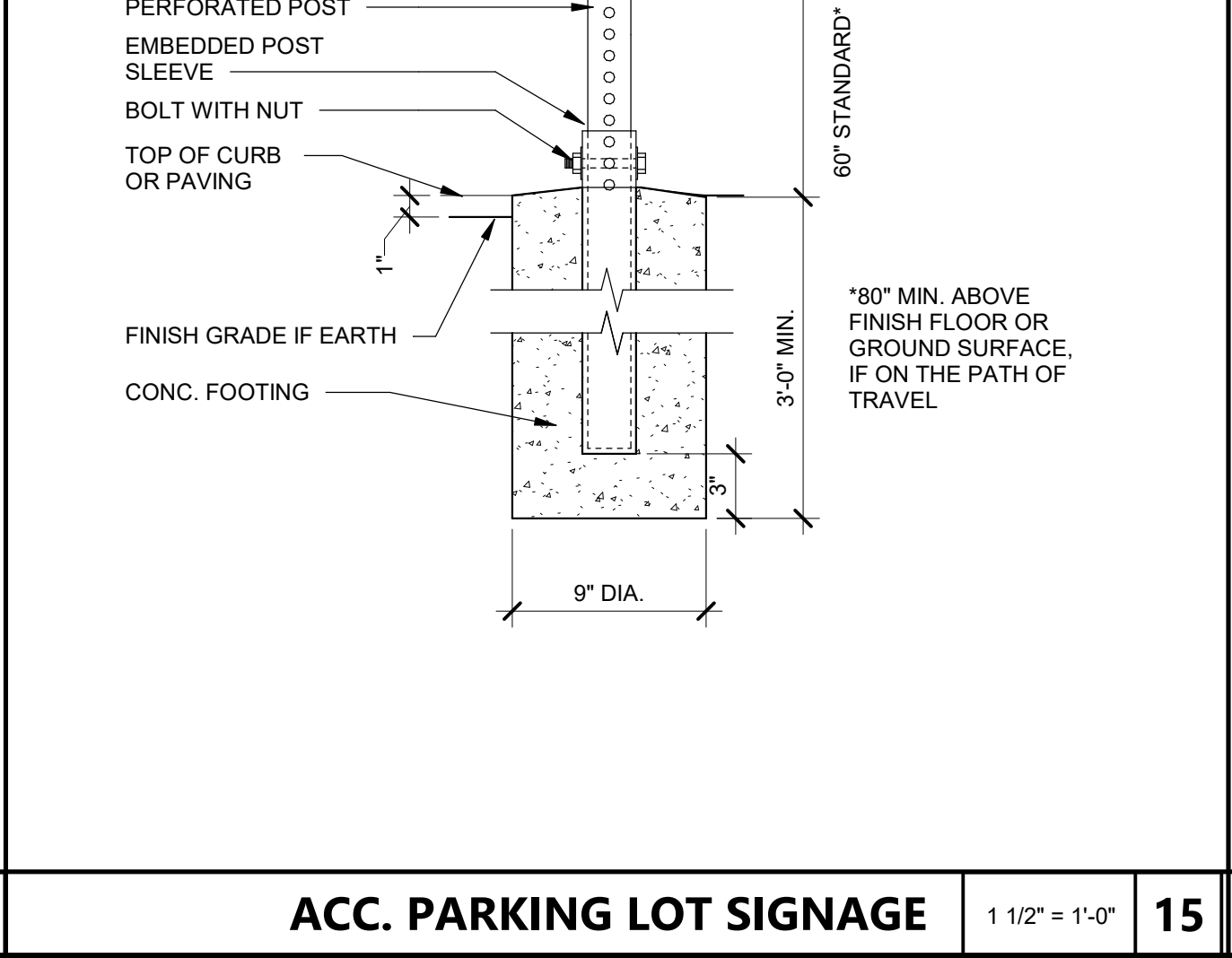
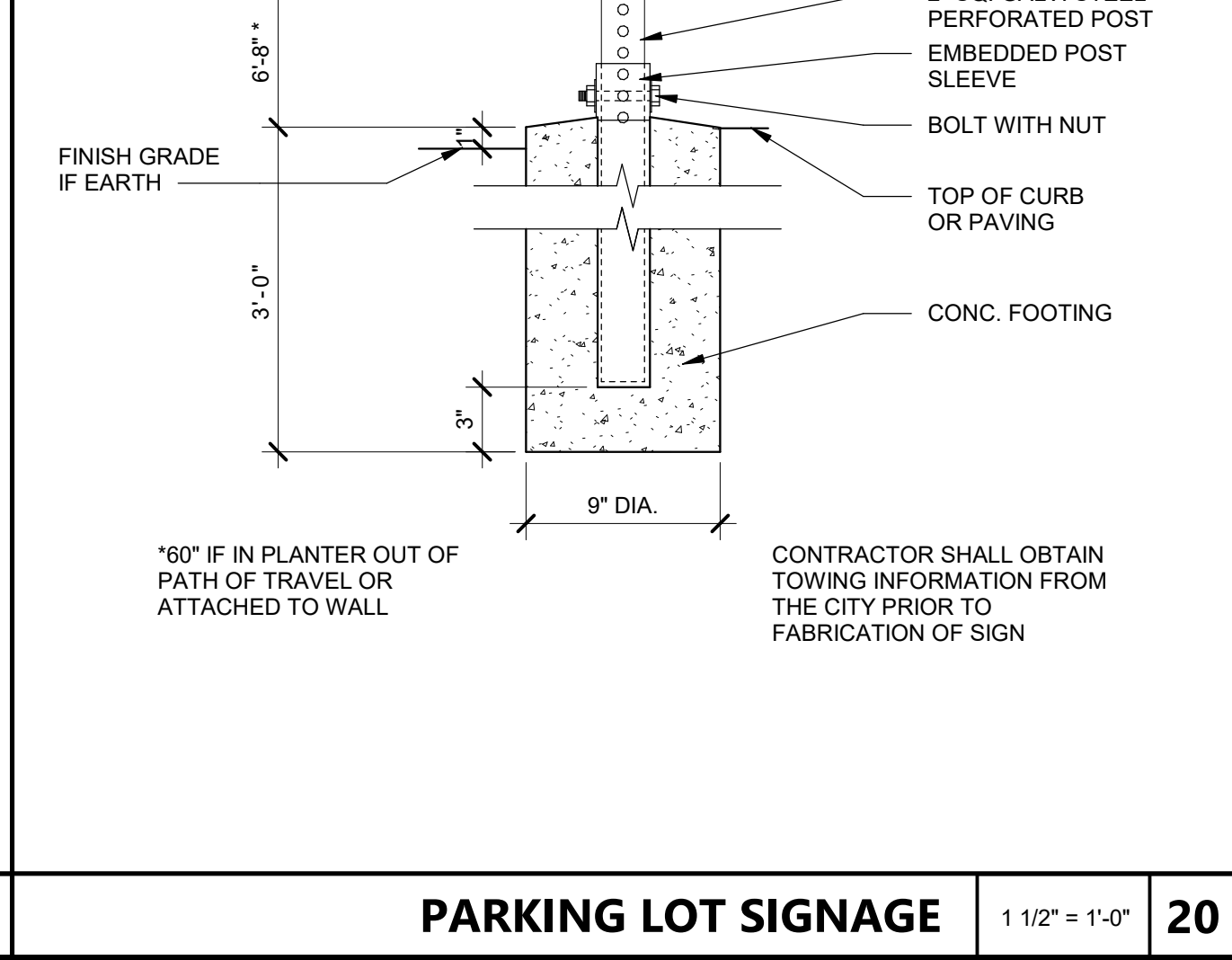
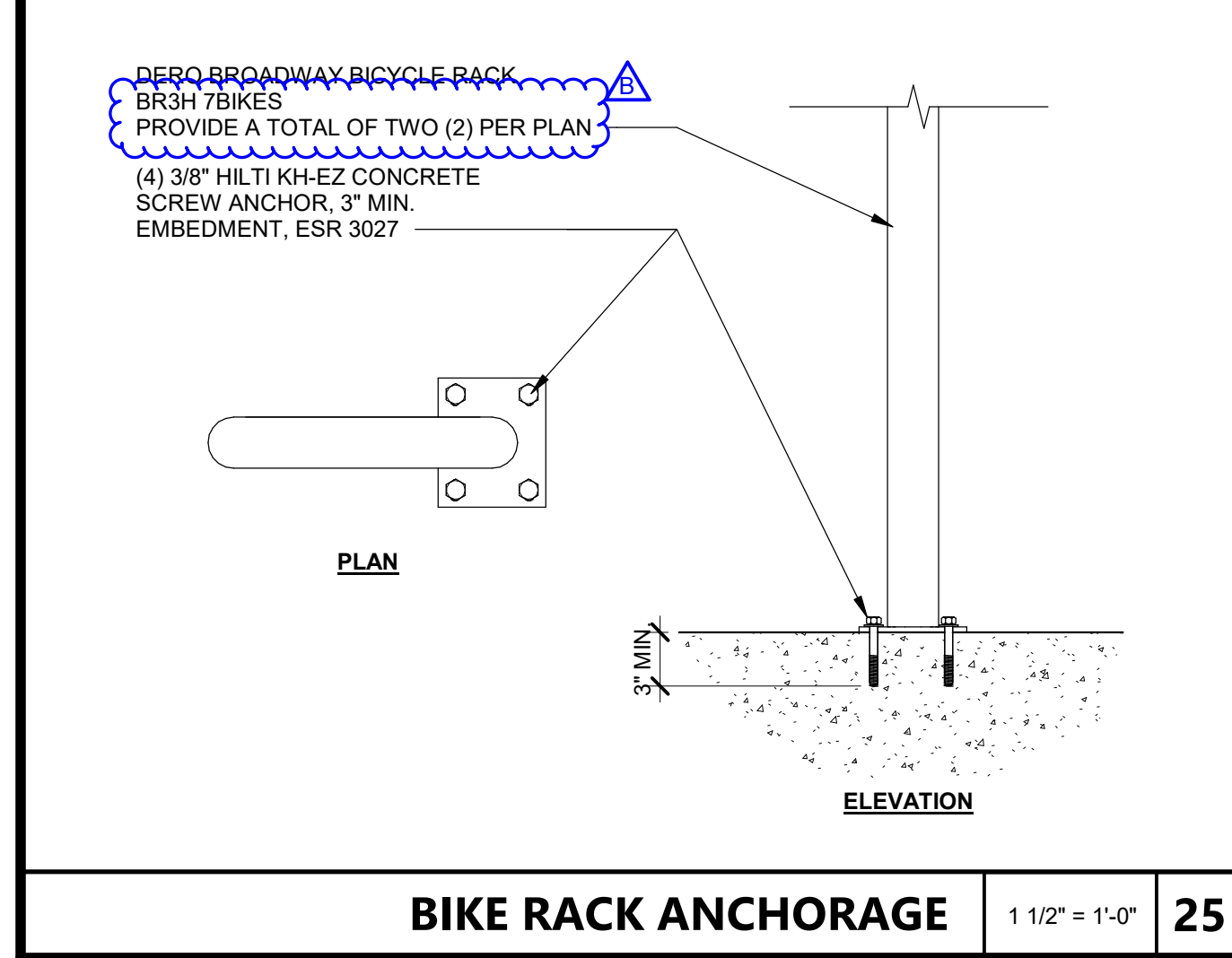

BIKE RACK ANCHORAGE 1 1/2" = 1'-0" **25**

PARKING LOT SIGNAGE 1 1/2" = 1'-0" **20**

ACC. PARKING LOT SIGNAGE 1 1/2" = 1'-0" **15**

DECORATIVE GATE FOOTING 1" = 1'-0" **10**

PARKING ACESIBILITY 1" = 1'-0" **5**

NOTE:
1. THE DETECTABLE WARNING SHALL BE YELLOW COLOR AND CONTRAST VISUALLY WITH ADJOINING SURFACE, EITHER LIGHT-ON-DARK OR DARK-ON-LIGHT (70% MIN. VISUAL CONTRAST) PER CBC 11B-705.1.1.3

AGENCY APPROVAL **DSAE** 03-121912



560 HIGUERA STREET, SUITE C
SAN LUIS OBISPO, CA 93401
TEL (805) 476-0399

- CONSULTANTS**
- CIVIL ENGINEER**
STANTEC CONSULTING SERVICES INC.
111 East Victoria Street
Santa Barbara, CA 93101
TEL (805) 680-6830
 - LANDSCAPE ARCHITECT**
OASIS ASSOCIATES
2427 Miguelito Court
San Luis Obispo, CA 93401
TEL (805) 541-4509
 - STRUCTURAL ENGINEER**
STORK, WOLFE & ASSOCIATES
555 Chorro Street, Suite A1
San Luis Obispo, CA 93405
TEL (805) 548-8600
 - MECHANICAL ENGINEER**
BMA MECHANICAL +
100 Cross Street, Suite 204
San Luis Obispo, CA 93401
TEL (805) 544-4269
 - ELECTRICAL ENGINEER**
THOMA ENGINEERING
3562 Empleo, Suite C
San Luis Obispo, CA 93406
TEL (805) 543-3850
 - FIRE PROTECTION ENGINEER**
BMA MECHANICAL +
100 Cross Street, Suite 204
San Luis Obispo, CA 93401
TEL (805) 544-42-69

ARCHITECT STAMP

CONSULTANT STAMP

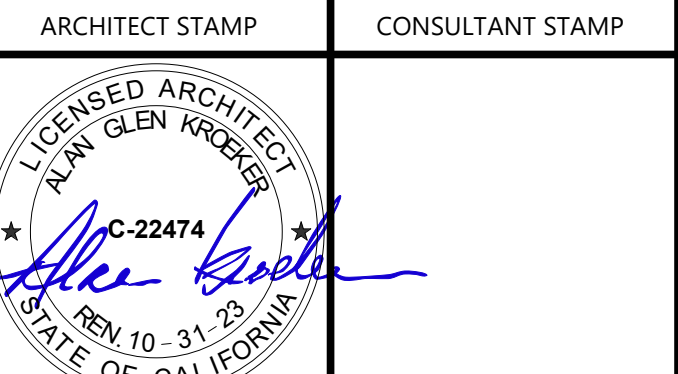
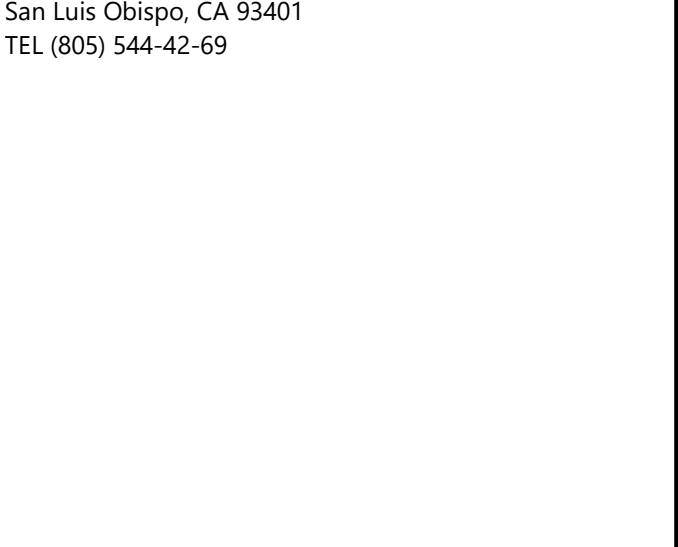

REVISIONS

NO.	DATE	DESCRIPTION
A	04-19-2022	Addendum 1
B	05-20-2022	ADDENDUM B

THE ARCHITECT DOES NOT REPRESENT THAT THESE PLANS OR THE SPECIFICATIONS ARE SUITABLE FOR ANY SITE OTHER THAN THE ONE FOR WHICH THEY WERE SPECIFICALLY PREPARED. THE ARCHITECT DISCLAIMS RESPONSIBILITY FOR THESE PLANS AND SPECIFICATIONS IF THEY ARE USED IN WHOLE OR IN PART AT ANY OTHER SITE.

PROJECT OWNER & TITLE
ORCUTT UNION SCHOOL DISTRICT
500 Dyer Street
Orcutt, CA 93455

ORCUTT ACADEMY HS MUR BUILDING
610 Pinal Avenue
Orcutt, CA 93455

SHEET TITLE
SITE DETAILS

DRAWN BY: XX JOB NUMBER: 20179.01

SHEET NO.
A-111

DATE: MAY 20, 2022

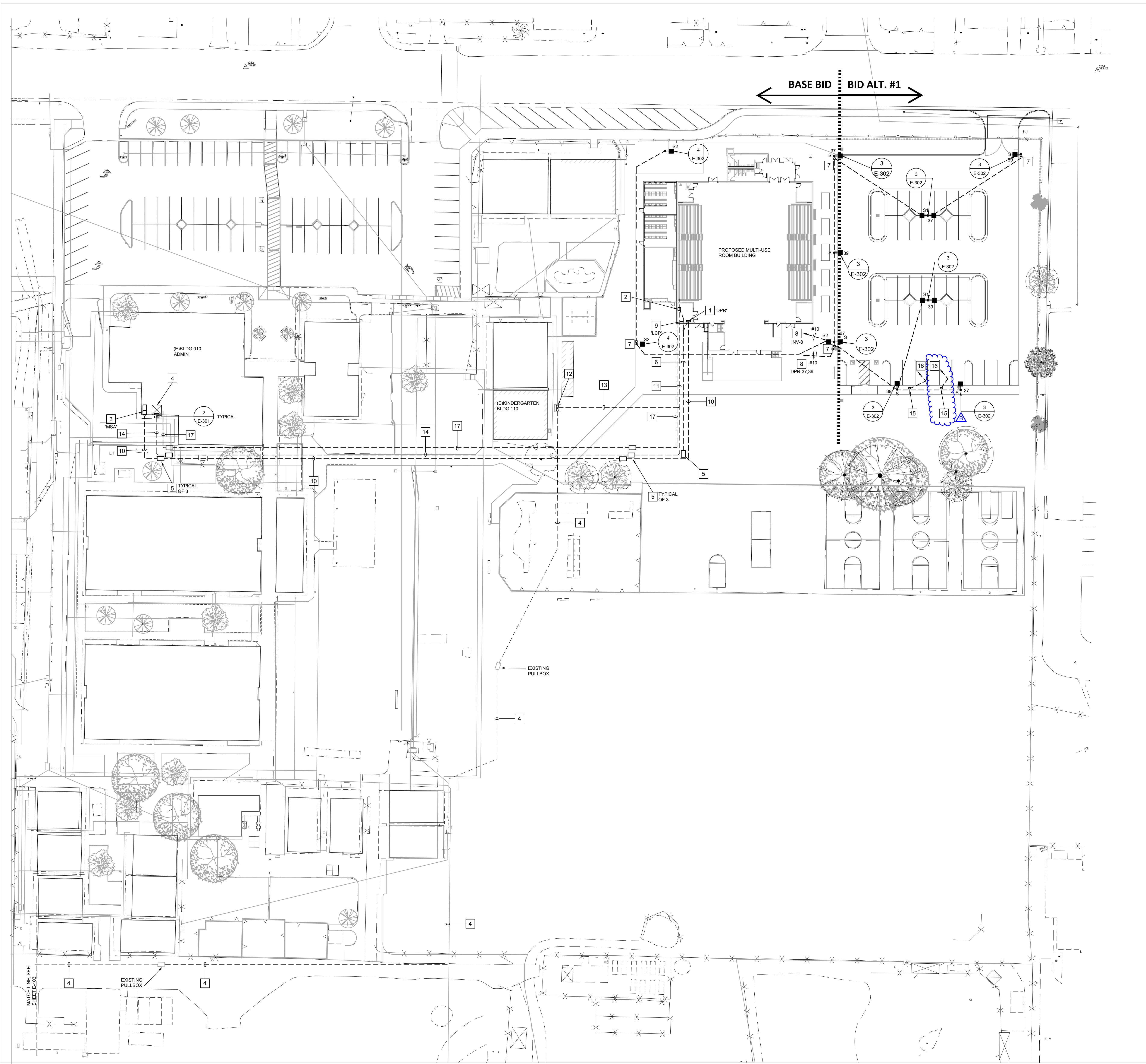

REFERENCE NOTES

1. DISTRIBUTION PANEL 'DPR', SEE SINGLE LINE DIAGRAM.
2. DATA DISTRIBUTION RACK, SEE SHEET E-501.
3. EXISTING MAIN SWBD MSA, SEE SINGLE LINE DIAGRAM.
4. (1) 3" EXISTING DATA / COMMUNICATIONS SYSTEM CONDUIT WITH PULLROPE TO REMAIN, INSTALL NEW FIBER OPTIC CABLING THRU EXISTING CONDUIT.
5. 3" X 5" CONCRETE PULLBOX, SEE MOUNTING DETAIL 9/E-301.
6. PROVIDE (2) 2" C.O. FROM DATA RACK AND (2) 2" C.O. FROM DISTRIBUTION PANEL DPR, STUB AND CAP CONDUITS FOR FUTURE USE.
7. 11" X 17" CONCRETE PULLBOX, PROVIDE WITH STEEL CHECKER PLATE LID WITH HOLD DOWN BOLTS, MOUNT FLUSH IN GRADE, SET OVER 12" OF CRUSHED ROCK.
8. ROUTE BRANCH CIRCUITS THROUGH LIGHTING CONTROL PANEL 'LCP', SEE LIGHTING CONTROL PANEL SCHEDULE ON SHEET E-303.
9. LIGHTING CONTROL PANEL 'LCP', SEE SHEET E-303.
10. UNDERGROUND FEEDER FROM MAIN SWBD MSA TO NEW DISTRIBUTION PANEL DPR WITH SPARE CONDUITS, SEE SINGLE LINE DIAGRAM.
11. (3) 4" COMMUNICATION SYSTEM CONDUITS, SEE COMMUNICATIONS RISER DIAGRAM FOR CABLING.
12. EXISTING COMMUNICATIONS PEDESTAL.
13. (1) 4" COMMUNICATION SYSTEM CONDUIT, SEE COMMUNICATIONS RISER DIAGRAM FOR CABLING.
14. (2) 4" COMMUNICATION SYSTEM CONDUITS, SEE COMMUNICATIONS RISER DIAGRAM FOR CABLING.
15. 11" X 17" U.L. LISTED FLUSH IN GRADE PULLBOX FOR FUTURE EVCS POWER.
16. (1) 2" C.O. TO PANEL DPR FOR FUTURE EVCS POWER CONNECTION, TERMINATE CONDUIT IN PULLBOX AS SHOWN.
17. (2) 4" SPARE CONDUITS, SEE SINGLE LINE DIAGRAM.

CONDUIT LEGEND

- NEW
- EXISTING TO REMAIN

SITE PLAN GENERAL NOTES

- A. TRENCHING AND BACKFILLING FOR ALL CONDUIT SYSTEMS SHALL BE THE RESPONSIBILITY OF THE ELECTRICAL CONTRACTOR. ALL CONDUITS SHALL HAVE MINIMUM COVER REQUIREMENTS AS SPECIFIED IN CEC 300-9. JOINT TRENCHING MAY BE UTILIZED WHERE PRACTICABLE AND WHERE PERMITTED BY THIS SPECIFICATION. TRENCHING OR BORING WILL BE AT CONTRACTORS OPTION.
- B. LOCATIONS OF EXISTING UNDERGROUND (UG) UTILITY SYSTEMS SHALL BE DETERMINED BY CALLING UNDERGROUND SERVICE ALERT (USA) WHEN PLANNING UNDERGROUND WORK, AND BEFORE YOU DIG, CONTACT UNDERGROUND SERVICE ALERT (USA) AT LEAST 48 HOURS PRIOR TO EXCAVATION (WEEKENDS EXCLUDED) FOR THE LOCATION OF UNDERGROUND GAS AND ELECTRIC LINES OR EQUIPMENT.
- C. MAINTAIN REQUIRED CLEARANCES FROM ALL SANITARY SEWER, WATER AND STORM DRAIN PIPING. REFER TO CIVIL PLANS FOR EXACT LOCATIONS AND DEPTHS OF PIPING.
- D. THE EXACT QUANTITY, LOCATION AND DEPTHS OF EXISTING UNDERGROUND PIPING AND CONDUITS IS UNKNOWN. FIELD VERIFY AND MAINTAIN EXISTING UTILITIES IN SERVICE AND PROTECT THEM AGAINST DAMAGE DURING DEMOLITION AND EXCAVATION OPERATIONS.
- E. REPAIR AND RECONNECT ALL EXISTING UNDERGROUND PIPING UNCOVERED AND DAMAGED BY NEW WORK AS REQUIRED TO MAINTAIN PROPER SYSTEM FUNCTIONS. RE-TEST ALL SYSTEMS DAMAGED BY NEW WORK.
- F. SAWCUT AND PATCH ALL SURFACES TO MATCH EXISTING SURFACES (CONCRETE, AC PAVING, ETC.) AS REQUIRED FOR INSTALLATION OF NEW WORK. COMPLETE FIELD VERIFICATION OF THIS WORK IS REQUIRED BY CONTRACTOR.
- G. SEE DETAIL 4/E-301 FOR ELECTRICAL/DATA/COMMUNICATION TRENCH DETAIL.



- CONSULTANTS**
- CIVIL ENGINEER**
STATTEC CONSULTING SERVICES INC.
111 East Victoria Street
Santa Barbara, CA 93101
TEL (805) 680-6830
 - LANDSCAPE ARCHITECT**
OASIS ASSOCIATES
3427 Maguillero Court
San Luis Obispo, CA 93401
TEL (805) 541-4509
 - STRUCTURAL ENGINEER**
STORK, WOLFE & ASSOCIATES
555 Chorro Street, Suite A1
San Luis Obispo, CA 93405
TEL (805) 548-9500
 - MECHANICAL ENGINEER**
BMA MECHANICAL +
100 Cross Street, Suite 204
San Luis Obispo, CA 93401
TEL (805) 544-4269
 - ELECTRICAL ENGINEER**
THOMA ENGINEERING
2562 Empire, Suite C
San Luis Obispo, CA 93406
TEL (805) 543-3850
 - FIRE PROTECTION ENGINEER**
BMA MECHANICAL +
100 Cross Street, Suite 204
San Luis Obispo, CA 93401
TEL (805) 544-42-69

ARCHITECT STAMP 	CONSULTANT STAMP
---------------------	----------------------

REVISIONS

#	DATE	DESCRIPTION
1	4/13/2022	ADDENDUM 1
2	05-08-2022	ADDENDUM 3
B	05-20-2022	ADDENDUM B

THE ARCHITECT DOES NOT REPRESENT THAT THESE PLANS OR THE SPECIFICATIONS ARE SUITABLE FOR ANY SITE OTHER THAN THE ONE FOR WHICH THEY WERE SPECIFICALLY PREPARED. THE ARCHITECT DISCLAIMS RESPONSIBILITY FOR THESE PLANS AND SPECIFICATIONS IF THEY ARE USED IN WHOLE OR IN PART AT ANY OTHER SITE.

PROJECT OWNER & TITLE
ORCUTT UNION SCHOOL DISTRICT
500 Dyer Street
Orcutt, CA 93455

ORCUTT ACADEMY HS MUR BUILDING
610 Pinal Avenue
Orcutt, CA 93455

SITE ELECTRICAL PLAN

DRAWN BY: TR JOB NUMBER: 20179-01

E-101

DATE: MAY 20, 2022

SITE ELECTRICAL PLAN
SCALE: 1"= 30'-0"
NORTH

DATE PLOTTED: FILE LOCATION:

ADDENDUM NO. 05

Project: Orcutt Union School District
Orcutt Academy High School
Multi-Use Room Building
19six No. 20179.01
DSA App. No.: 03-121912 File No.: N/A
Bid No.:
Date: May 23, 2022

To all bidders submitting proposals for the above captioned project. This Addendum is hereby included in the Contract Documents to the same extent as though it were originally included therein. The following items modify, add to, delete from, or explain the drawings and/or specifications. The contents of this Addendum shall take precedence over the original specifications and plans.

SPECIFICATIONS

Item #1: **Roofing.** Revise specifications for Single Ply Membrane Roofing. See revised specification section 07 54 16 Single Ply Membrane Roofing.

DRAWINGS

Item #2: **Fencing.** Revise fencing. See revised sheets G-101 and A-101 and A-102.

Item #3: **Volleyball Post Floor Sleeves.** Revise locations of volleyball floor sleeves. See revised sheets A-201 and A-202.

Item #4: **Tile.** Add tile information on Finish Schedule. See revised sheet A-251.

ATTACHMENTS:

07 54 16 SINGLE PLY MEMBRANE ROOFING
G-101 CODE SITE PLAN
A-101 SITE PLAN
A-102 ENLARGED SITE PLAN
A-201 FLOOR PLAN
A-202 COURT STRIPING
A-251 FINISH PLAN



Alan Kroeker

C-22474

SECTION 07 54 16 – KEE MEMBRANE ROOFING

PART 1 - PART 1 – GENERAL

1. summary

A. Scope

1. Furnish and install an adhered FiberTite Roofing System as manufactured and supplied by:

Seaman Corporation
1000 Venture Blvd.
Wooster, Ohio 44691
Tel.: 1-800-927-8578
Fax: 1-800-649-2737

B. Special Conditions

1. This specification is applicable to only those building roofs that have decking of sufficient structural integrity, capable of supporting a FiberTite Roofing System according to the guidelines set forth herein.
2. All applications and project specifications require review by FiberTite Technical Customer Services (FTCS) for acceptance prior to any commitment to provide a commercial warranty.
3. Seaman Corporation FiberTite Pre-installation Notice (FTR-PIN), must be completed, signed by an authorized roofing contractor, submitted to and approved by FTCS before any consideration for warranty and/or the release of any materials can be authorized.

C. Special Design Considerations

1. The building owner may be required to submit an engineering study, or Statement of Sound Roof Structure, to FTCS, indicating that the structure is able to accommodate additional live and/or dead loads including snow and water retention.
2. Moisture conditions in existing roof(s), new structural concrete or new lightweight insulating concrete which would impair or prohibit the desired performance of the new roof system.
3. Coal tar recover and/or direct contact with bituminous materials.
4. Positive slope to promote adequate drainage to avoid the potential damage to the substrate or components.
5. Roof areas subject to heavy or excessive mechanical traffic.

D. Environmental Considerations

1. Chemical discharge not listed on the Seaman Corporation/FiberTite chemical resistance publication.

2. Environmental conditions such as fog, dew, rain or snow and/or freezing temperatures can have a detrimental effect on the application and performance of adhesives.
3. Compliance with EPA and OSHA requirements as published by local, state and federal authorities.
4. All adhesives can be described as temperamental. The contractor must be aware of all potential environmental variables when installing adhered roofing systems.
5. Pay particular attention to and follow all adhesive storage and application precautions/guidelines.
6. Do not apply/use waterborne adhesives (FTR-490 or FTR 390) if the ambient air temperature is expected to drop below 32°F (0°C) within 72 hours of application.
7. The use of polystyrene insulation/coverboard assemblies for adhered roofing systems incorporating solvent borne adhesives shall also include a minimum 10-mil polyethylene solvent barrier between the insulation and coverboard.

2. FIBERTITE ROOFING SYSTEMS (FTR) REFERENCES

- A. FiberTite Construction Details
- B. FiberTite Foreman's Manual
- C. FTR GS08/17
- D. FiberTite Technical Bulletins

3. QUALITY ASSURANCE

- A. FiberTite Roofing Systems shall be installed only by a roofing contractor, authorized by Seaman Corporation to install FiberTite Roofing Systems prior to bid and/or contract award. Herein, the term Authorized FiberTite Roofing Contractor is synonymous with authorized, roofing contractor and/or contractor.
- B. Roofing contractor's key personnel shall have received specialized training in the installation of FiberTite Roofing Systems by Seaman Corporation.
- C. FiberTite Roofing Systems shall be installed in accordance with the most current guide specifications (FTR AD08/17) and details as amended and/or authorized by FTCS for specific project requirements.
- D. There shall be no deviations from approved contract specifications or shop drawings without prior written approval by the owner/owner representative and FTCS.
- E. Unauthorized deviations may subject the roof system to warranty ineligibility.

- F. Any and all work found to be substandard or in violation of the Contract Documents or Manufacturer's Specifications shall be subject to rejection including complete removal and replacement with new materials at the expense of the contractor.
- G. Upon completion and certification by the contractor that a quality installation has been completed in accordance with the approved contract specifications and all field welds have been probed and inspected, a quality assurance inspection of the roof system shall be performed by FTCS for acceptance and approval.
- H. All field seams shall be visible and available to FTCS at the time of final inspection.

4. SUBMITTALS

- A. The following information shall be submitted to FTCS for review before warranty consideration, material shipment or acceptance can be confirmed.
 - 1. Complete copy of project architectural specifications or roofing contractor's proposal outlining design parameters.
 - 2. Complete list of accessories or materials not manufactured or expressly authorized for use in FiberTite literature.
 - 3. Dimensioned outline of the roof indicating all FTR-Detail references.
 - 4. Dimensioned shop drawings illustrating non-FiberTite details. Details that do not conform with standard FiberTite details shall be returned with appropriate recommendations.
- B. At the time of contract award, the roofing contractor shall submit to the owner/owner's representative the following:
 - 1. Most recent published technical literature and guide specifications issued by FTCS.
 - 2. Roofing Contractor's approved copy of submittal form FTR-PIN.
 - 3. Dimensioned shop drawings, including roof plan detailing perimeter enhancement, flashing methods, terminations and acceptance by FTCS.
 - 4. Written approval from FTCS confirming any accessories submitted, not manufactured or expressly approved in FiberTite literature are acceptable and compatible with the proposed FiberTite Roofing System.
 - 5. Material Safety Data Sheets (MSDS) relating to all products, chemicals and solvents.
 - 6. Certification that the system specified complies with all identifiable building code and insurance requirements.

5. DELIVERY & STORAGE

- A. Deliver all materials to the job site in manufacturer's original, unopened containers, with legible labels and in sufficient quantity to allow for continuity of work.
- B. Select and operate material handling equipment in a safe manner, guarding against damage to existing construction or newly applied roofing and conforming to manufacturer's recommendations of handling and storage.
- C. All rolls of membrane shall be stored, lying down, elevated above the roof deck and completely protected from moisture with tarpaulins. Manufacturer's packaging is not considered adequate for outdoor storage.
- D. Insulation and cover board materials shall be elevated on pallets and fully protected from moisture with tarpaulins. Manufacturer's packaging is not considered adequate protection from moisture.
- E. All adhesives and sealants shall be safely stored between 50° F and 80°F prior to use.
- F. Flammable materials shall be stored in a cool, dry area away from sparks and open flames. Follow all precautions as outlined in manufacturer's Material Safety Data Sheets.
- G. Materials, having been determined by the owner/owner's representative to be damaged, shall be immediately removed from the construction site and replaced at no cost to the owner.

6. JOB CONDITIONS

A. Safety

- 1. Take all necessary precautions regarding worker health and safety when using solvents and adhesives
- 2. Worker safety is paramount when working on steep slopes.
- 3. FiberTite is slippery when wet, exhibits dew, frost, ice or any other form of moisture.
- 4. Comply with all OSHA requirements for roof construction and fall protection where required.
- 5. Store flammable liquid and materials away from open sparks, flames and extreme heat.
- 6. Take necessary precautions when using solvents and adhesives near fresh air intakes.
- 7. Daily site cleanup shall be performed to minimize debris and hazardous congestion.

B. Protection

- 1. Schedule installation sequence to limit access and utilization of the newly installed membrane for material storage, construction staging, mechanical and/or excessive foot traffic.
- 2. Provide proper protection on all newly completed roofing to avoid damage to the new roofing system.
- 3. Traffic should be minimized on a freshly laid roof.
- 4. Protect building walls, rooftop units, windows and other components during installation.

C. Additional Precautions

1. Adverse weather conditions e.g. extreme temperature, high winds, high humidity and moisture, could have a detrimental effect on adhesives, general production efforts and/or the quality of the finished installation. Contact FTCS for recommendations and acceptable tolerances.
2. Daily production schedules of new roofing shall be limited to only that which can be made 100% watertight at the end of the day, including all flashing and night seals.
3. All surfaces to receive the new roof system, including insulation and flashing, shall be free from all dirt, debris and be thoroughly dry.
4. Comply with local EPA requirements as published by local, state and federal authorities.
5. All construction debris shall be removed from the construction site and legally dispose of offsite.

7. COORDINATION

- A. Prior to installation of materials, a pre-roofing conference shall be held with the roofing contractor, and owner/owner's representative(s) to discuss the specified roofing system, coordinate its proper application and the expectations of all parties involved. The authorized roofing contractor and the owner/owner's representative shall notify all parties a minimum of fourteen days prior to the meeting.
- B. Plan and coordinate the installation of the roofing system with other trades in such a manner to avoid membrane damage, keeping the complete installation weather tight and in accordance with all approved details and warranty requirements.
- C. FTCS shall be available to make recommendations necessary to ensure compliance with project specifications and specification alternatives due to unforeseen job conditions.
- D. Field services are provided at the discretion of Seaman Corporation. A minimum two weeks notice is required to evaluate and coordinate any request for onsite technical assistance.

8. WARRANTY

- A. Inspections
 1. A FiberTite Technical Customer Service Representative shall inspect the completed FiberTite Roofing installation, and upon acceptance, Seaman Corporation shall issue the preauthorized warranty, subject to the terms and conditions of the sample warranty and contract documents.
- B. Available Warranties
 1. Seaman Corporation offers the following FiberTite Roofing System warranties:

- a. **Provide** Material Warranty provides the building owner protection against the cost of repairing defects in the membrane only. This warranty is offered at no cost to the owner. 20 year NDL.
- b. **Provide Fibertite's Standard** Warranty which provides the building owner protection against the cost of repairing leaks as a direct result of either defects in the membrane or the workmanship involved in its installation for a period of **25 years plus 5 year extension.**

C. Maintenance

1. Along with the issuance of the warranty, a set of instructions shall be included detailing preventative maintenance requirements on the part of the building owner and noting a list of harmful substances which may damage the FiberTite roofing membrane.

PART 2 - PART 2 – PRODUCTS

PART 3 - GENERAL

- A. All products and components for the FiberTite Roofing System shall be supplied by Seaman Corporation.
- B. Components other than those manufactured and/or supplied by Seaman Corporation shall be submitted for review, prior to ordering. Any product(s) not specifically authorized in writing for the project by Seaman Corporation, shall be considered unacceptable and their performance excluded from the warranty.
- C. FiberTite Roofing Systems may be installed over or directly to preapproved insulation, cover board or composites thereof. Contact FTCS for additional information regarding compatible substrates.

PART 4 - MEMBRANE

A. Manufacturers

1. Basis of Design: **50 Mil FiberTite-XT-FB per ICC-ESR 1456.** FiberTite-FB membranes have a heat bonded 4 oz. polyester backing, as manufactured by Seaman Corporation, under the trade name FiberTite-FB, conforming to the physical properties as outlined in the associated data sheet(s). FiberTite-FB exceeds the physical property requirements and definitions as outlined in ASTM D6754 Standard Specification for Ketone Ethylene Ester (KEE) Sheet Roofing per the individual sub-assembly/base membrane listed above.
2. Or approved equal. Substitutions will be considered after job is awarded. Any proposed substitutions will have to be accompanied by a product comparison of proposed product compared to the basis of design. Proposed product shall be equal or better than specified product in the following categories but not limited to quality, performance and warranty. Failure to comply with this requirement or should the proposed product be found to not to be equal will result in contractor having to provide the original specified product.

B. Flashing Membrane

50 Mil FiberTite-XT-FB membrane shall be used for all respective roofing system flashing requirements to match the field membrane and warranty expectations selected for the roofing system.

C. Acceptable Substrate(s)

1. Authorized rigid insulation or cover board
2. Structural Concrete, insulated or non-insulated
3. Insulated Steel Decking
4. Existing smooth surfaced and/or granulated bituminous roof or existing single ply roof membrane
5. Existing aggregate surfaced bituminous roof with authorized insulation or cover board
6. Exterior grade plywood; insulated or non-insulated
7. Cementitious fiber or Gypsum, insulated or non-insulated
8. Cellular, lightweight insulating concrete
9. Authorized base sheet with an adhered insulation/coverboard assembly

PART 5 - RELATED MATERIALS "BY SEAMAN CORPORATION"

The following product(s)/material(s) shall be supplied by Seaman Corporation.

A. FTR Adhesives

Adhesives, supplied by Seaman Corporation have been specially formulated for FiberTite Roofing Systems.

1. FTR-490 Adhesive

A polymeric water borne, VOC compliant adhesive, one side application (substrate only), designed for bonding FiberTite-FB (fleeceback) to properly prepared and preauthorized horizontal substrates.

2. ICP CR-20 Adhesive

A dual component elastomeric polyurethane froth adhesive designed for bonding Fleece Back FiberTite membranes (spatter application) to properly prepared and preauthorized horizontal substrates.

3. FTR #201 Mastic

A trowel grade elastomeric adhesive/sealant used to adhere FiberTite flashing membranes to preapproved vertical substrates.

B. FTR Fasteners

1. FiberTite MAGNUM Series

To secure FiberTite Membranes to steel, wood and structural concrete decks. A #15-13, buttress threaded, #3 Phillips head fastener constructed of case hardened carbon steel with a reduced diameter drill point and corrosion resistant coating.

2. FiberTite-HD

To secure insulation to steel, wood and structural concrete decks. A #14-13, heavy duty threaded steel #3 Phillips truss, self tapping corrosion resistant fastener.

3. FiberTite Peel Rivets

To secure insulation, base sheet and/or membrane to steel, wood, cement fiber, Tectum fiberglass and lightweight plank decks. Threadless, high magnesium alloy fastener.

4. FiberTite Purlin Fasteners

To secure FiberTite membrane to the existing metal roofing system's structural members.

5. FiberTite BS Fasteners

Coated fastener and stress plate to secure base sheets to gypsum and cellular lightweight insulating concrete decks.

C. FTR Stress Plates

1. FTR-Magnum Series Barbed Stress Plates – used to anchor FiberTite membranes:

- a. FTR Magnum Plus – 1.5” x 2.75” Barbed Rectangular Stress Plate with radial corners; manufactured from 18- gauge AZ-50 galvalume steel.
- b. FTR Magnum R275 – 2.75” Barbed Round Stress Plate: manufactured from 20-gauge galvanized steel.
- c. FTR Magnum 2S – 2.375” Barbed Round Stress Plate; manufactured from 20-gauge galvanized steel.

2. FTR 3-in Metal Round Insulation Stress Plates- Finished with AZ-50 galvalume and have a flat/flush profile for use on rigid board surfaces.

D. Additional Components

1. FTR-101 Sealant - A single-component gun-grade polyether sealant to seal flashing termination.
2. FTR-SLS Sealant - A single-component self leveling polyether sealant for pitch pans.
3. FiberClad Metal - To fabricate metal flashing, 4' x 10' sheets of 24 gauge hot dipped G-90 steel, or 0.040" thick 3003H14 aluminum, laminated with a 0.02-mil polymeric coating.
4. FTR-Premolded Flashing(s) - Injection molded vent stack, split WrapidFlash® and inside/outside corner flashing using FiberTite vinyl compound.
5. FTR Non-Reinforced Membrane - Field fabrication membrane, 60-mil non-reinforced FiberTite vinyl membrane.
6. FTR-Tuff Track Walkway & Protection Pads - High grade walk way/protection material with slip resistant design.
7. FTR-Termination Bar - Membrane flashing(s) restraint/termination seals, nominal 0.125" x 1" x 10' 6060-T5 extruded aluminum bar with pre-punched slots, 8 inches on center.
8. FiberTite Metal Fascia System - Two piece snap-on preformed architectural Kynar metal edge systems.
9. FTR-Value Insulation - Polyisocyanurate and extruded polystyrene flat or tapered insulation.
10. FTR-601 - Dual component, single bead (ribbon applied) urethane insulation adhesive in either cartridges or pump grade. Adhesive is a non-solvent, elastomeric, urethane adhesive, specifically designed for bonding single or multiple layers of roof insulation and insulation composites and/or cover boards to structural roof decks and base sheets.
11. FiberTite VaporTite - a self-adhered bitumen and SBS polymeric Class I Vapor Barrier.
12. FiberTite Seam Cleaner - FiberTite Seam Cleaner is to be used with clean white cotton cloths/rags to clean contamination from the seam areas of the membrane prior to welding.
13. Simulated Metal Roofing Profile (Rib) – The simulated metal roofing profile shall be a Co-Extruded Ornamental Profile with a KEE compatible heat-activated adhesive as provided by Seaman Corporation.
 - a. Extruded profile shall be provided in 100 feet continuous lengths and match fleece back membrane color.
14. FTR T-Joint Covers – Pre-cut 4" x 4" 60 mil non-reinforced membrane to reinforce areas where three overlapping sheets of membrane intersect.

15. FTR-Cover Board – Secure Rock Gypsum Fiber, 1/4“ mechanically attached.

PART 6 - RELATED MATERIALS

A. Wood Nailers

1. Wood Nailers are being tested to determine the effect of preservatives on metal components. Borate treated lumber seem to be the less corrosive and is strongly recommended. Installation of other types of treated lumber should be verified with a design professional.
2. Wood shall be No. 2 or better construction grade lumber.
3. Creosote or asphaltic type preservatives are not acceptable.
4. Minimum top nailer thickness shall be 1.5 inches nominal.

PART 3 EXECUTION

PART 7 - GENERAL

- A. The “Authorized” roofing contractor shall ensure strict compliance with FTR GS 02/13; General Guide Specifications for Installation of FiberTite Roofing Systems.
- B. The roofing contractor shall provide a suitable substrate surface for the proper installation of the FiberTite Roofing System, roof insulation and specified components.
- C. Application of Seaman Corporation/FiberTite materials constitutes an agreement that the roofing contractor has inspected and found the substrate suitable for the installation of the FiberTite Roofing System.
- D. The roofing contractor shall coordinate the installation to ensure that the system remains watertight at the end of each working day.

PART 8 - SUBSTRATE PREPARATION

- A. The roofing contractor shall verify that the deck condition and/or existing roof construction is suitable for the specified installation of the FiberTite Roofing System.
- B. Seaman Corporation requires fastener withdrawal values (pull out tests) on all reroofing projects to verify the suitability of decking to accept a mechanically fastened insulation and/or membrane roof system.
- C. Examine surfaces for inadequate anchorage, low areas that will not drain properly, foreign material, ice, wet insulation, unevenness or any other defect which would prevent the proper execution and quality application of the FiberTite Roofing System as specified.
- D. Prepared substrate shall be smooth, dry, and free of debris and/or any other irregularities which would interfere with the proper installation of the FiberTite Roofing System.

- E. The application of adhesives or hot asphalt directly to structural concrete, gypsum, Tectum, lightweight insulating concrete, existing smooth an /or granulated BUR materials may require sealing or priming with an appropriate elastomeric or asphalt primer prior to application.
- F. Adhesives will not bond to wet, damp or inadequately cured lightweight insulating concrete or poured structural concrete.
- G. Do not proceed with any part of the application until all defects and preparation work have been corrected and complete.

PART 9 - SUBSTRATE PREPARATION (ReRoofing)

A. General

- 1. Roofing Contractor shall inform the building owner/owner representative of any issues in regard to the condition and structural integrity of the existing decking.
- 2. The building owner/owner representative shall make and be responsible for the determination as to the proper method of treatment and/or replacement.
- 3. Reroofing applications require fastener withdrawal tests to substantiate proposed attachment patterns for the new mechanically fastened insulation systems and/or membranes.
- 4. Reroofing applications that require modification to the deck and/or insulation system should be installed to provide positive slope and subsequent positive drainage of the new FiberTite Roofing System.
- 5. All terminations of the FiberTite Roofing System must be constructed to prevent water from penetrating behind or beneath the new FiberTite Roofing System. This includes water from above, beside, below and beneath the new system.

B. Removal of Existing Roof System(s)

- 1. Remove all existing roofing material(s), insulation, flashing, metal and deteriorated wood blocking and legally dispose of off site.
- 2. Remove only enough roofing to accommodate the day's work and ensure the exposed area can be made 100% watertight at the end of the day or prior to inclement weather.

C. Re-Cover of Existing Roof System(s)

- 1. Remove all loose aggregate and debris by power broom and/or vacuum and legally dispose of off site.
- 2. Remove and replace all wet or deteriorated insulation and wood blocking.

3. Clean all exposed metal surfaces such as pipes, pipe sleeves, drains, duct work, etc., by removing loose paint, rust and any asphalt or coal tar pitch of any kind. Remove and properly discard lead sleeves at soil stacks.
4. If the existing roof is coal tar pitch, has been repaired with coal tar pitch or has been resaturated with coal tar pitch, a minimum 10-mil polyethylene pitch vapor retarder shall be installed before recovering.

D. Steel and Wood Decks

1. All rotted and/or deteriorated decking shall be removed and replaced with like kind.
2. Areas of structurally acceptable steel decking exhibiting slight surface rust shall be properly cleaned, primed and painted prior to installing the approved insulation.
3. All decking shall be inspected for proper attachment and excessive deflection that would compromise the uplift performance of the new FiberTite Roofing System.
4. Attachment and deflection deficiencies shall be repaired and brought into compliance with current, local building code requirements.

PART 10 - WOOD NAILERS

- A. Install treated lumber at the same heights as insulation layer or adjacent construction \pm 0.25 inch. Continuous treated wood nailers are to be installed at all perimeters, around roof projections and penetrations as shown in approved details.
- B. Where wood nailers are installed directly on the substrate, the substrate shall be carefully examined to confirm that the entire area provides a suitable fastening surface. All defects shall be repaired by the appropriate trade prior to installation.
- C. Nailers shall be at least 3.5 inches wide and 1.5 inches high and installed and anchored in such a manner to resist a force of 250 lbs. per linear foot of wood blocking in any direction.
- D. Nailers along parapets, curbs and expansion joints are recommended for insulated decking. Consult FiberTite Construction Details or FiberTite Technical Customer Services for optional/alternate membrane termination/securement methods.

PART 11 - BASE SHEET

A. General

1. Approved base sheet, when required or specified, shall be applied only to properly prepared and preapproved substrates.
2. Install no more than can be covered or made 100% water tight during the same working day.

3. Field pull-out tests must be performed for mechanically attached base sheets to determine fastener withdrawal performance.
4. Base sheets shall be installed starting at the low point of the roof deck.
5. Base sheet shall be side lapped, a minimum of 3 inches, and properly shingled to shed water.

B. Mechanically Attached Base Sheet

1. All base ply fasteners and stress plates for the mechanical attachment of base sheets shall be provided by Seaman Corporation.
2. For 1-90 attachment, approved base sheet is secured to the deck in the field of the roof, with FiberTite Fasteners, spaced a maximum of 7 inches on center through the minimum 3 inch side laps and staggered at a maximum 7 inch on center in two rows within the field of the sheet.
3. The number of fasteners securing the base sheet shall be increased over the field spacing by 70% in the perimeter and 160% in the corners of the roof area.
4. Fastening increases can be obtained by adding rows of fasteners and/or additional fasteners along each row.

C. Base Sheet Adhered with Hot Asphalt

1. Hot asphalt shall be applied only to properly prepared and preapproved substrates, free of any debris, dirt, grease, oil or moisture.
2. Base sheet shall be embedded into a fluid, continuous application of hot Type III steep asphalt at a minimum application rate of 25 lbs. per 100 square feet.
3. Base sheet shall be fully bonded to the substrate.

PART 12 - INSTALLATION OF FIBERTITE MEMBRANE(S)

A. Quality Control

1. It is the responsibility of the roofing contractor to initiate and maintain a Quality Control program to govern all aspects of the installation of the FiberTite Roofing System.
2. The project foreman and or supervisor will be responsible for the daily execution of the Quality Control program which will include but is not limited to the supervision, inspection and probing of all heat welded seams incorporated within the FiberTite Roofing System.
3. If inconsistencies in the quality of the application of the composite, membrane and/or welds are found, all work shall cease until corrective actions are taken to ensure the continuity the installation.

B. General

1. Work shall be coordinated to ensure that sequencing of the installation promotes a 100% watertight installation at the end of each day.
2. All FiberTite Roofing Systems shall be designed utilizing and determined to be in compliance with the procedures outlined within the current publication of ASCE Standard 7. Alternative designs may be determined using the criteria within Factory Mutual Research Loss Prevention Data.
3. A FiberTite Roofing Systems may utilize either conventional roll goods or custom prewelded panel rolls or a combination of both.
4. Restrictions regarding outside ambient air temperature are relative only to the exposure limits of the workers and/or adhesives when necessary.
5. When using adhesives outside ambient air temperature shall be above 40°F. Curing or drying time of the adhesive will be affected by ambient temperatures and must be taken into consideration.
6. Humidity can affect the drying time of solvent borne adhesives and/or cause condensation to form on the newly applied adhesive.
7. No moisture may be present on the adhesive(s) prior to mating or application of FiberTite membranes.
8. All adhered membrane systems are to be broomed in place first and then completed by pressing the membrane into the adhesive with a weighted, foam covered lawn roller or 50-lb linoleum roller. Lawn rollers should be filled with between 6 and 8 gallons (48 – 64 pounds) of water.
9. FiberTite Roofing Systems shall only be installed over properly prepared and sound substrates, free from excessive surface roughness, dirt, debris and moisture.

C. Adhered Membrane

1. The authorized roofing contractor shall assume full responsibility for any and all irregularities, defects or quality issues that arise due to failure to following published installation guidelines for the proper installation of adhered FiberTite membrane roofing systems.
2. FiberTite Fleece Back Membrane Adhered in FTR-490 Adhesive
 - a. For “all” FB membranes - Unroll approximately 30 feet of the FiberTite-FB membrane and position the roll over the properly installed/prepared substrate. Pull the tail back over the roll to expose a workable area (approx. 30') of substrate.
 - b. Apply a 100% continuous coat of adhesive to the substrate

- c. The amount of substrate that can be coated with a workable amount of adhesive will be determined by application method, ambient temperature, humidity, and available manpower.
 - d. To ensure proper application and curing of the adhesive, the outside air temperature shall be above 40°F and rising.
 - e. FTR-490 adhesive is to be applied by spraying and back rolling or just rolling. Do not dump adhesive or pour from the cans.
 - f. Roller applied adhesive shall utilize a solvent resistant $\frac{3}{8}$ inch nap roller.
 - g. Adhesive must be rolled out to ensure a smooth, even 100% coverage of the substrate with no voids, skips, globs, puddles, or similar irregularities.
 - h. Allow the adhesive to set up only to the point that the adhesive is slightly cured but still wet. Do not allow adhesive to skin or dry out.
 - i. Water borne adhesives (FTR-490) can be directly affected by moisture. Water based adhesives shall not to be installed over/on substrates that are moist or wet or on systems or substrates that have residual moisture.
 - j. Broom the adhered portion of the membrane to ensure full contact and complete the bonding process by firmly pressing the bonded membrane into place with a weighted, foam-covered, lawn roller.
 - k. Repeat the process for the remaining un-bonded portion of the membrane, lapping subsequent, adjacent rolls of membrane a minimum of 3 inches, ensuring proper shingling of the membrane to shed water along the laps.
 - l. No adhesive shall be applied to the lap "seam" areas of the membrane. Areas contaminated with adhesive are difficult to clean, will impair proper welding of the seams and require a membrane patch or strip.
 - m. Do not use bad or marginal adhesives. Contact FTCS if the quality of the adhesive is suspect.
3. FiberTite Fleece Back Membrane Adhered in FT /CR-20 Adhesive
- a. For *all* FB membranes, un-roll and position two rolls of FiberTite-FB over the properly installed/prepared substrate.
 - b. Ensure rolls are straight and the minimum 3 inch overlap between rolls is maintained.
 - c. Peel (butterfly) the rolls back in the long direction, half way upon themselves to expose the substrate and the underlying polyester fleece backing.

- d. Apply continuous spatter pattern of FiberTite CR-20 adhesive to the substrate between the rolls; dispensing the adhesive in a spattered pop-corn spray pattern.
- e. Spatter pattern shall achieve a nominal 80% coverage of textured coating at approximately 0.25 inch nominal thickness. The balance of the substrate will get coated as the adhesive spreads during the brooming and rolling process.
- f. Avoid spattering the back of the FB membrane.
- g. Do not allow adhesive to contaminate membrane overlaps. Use a sheet of insulation board to mask the spray area along adjoining membrane areas.
- h. Overspray may be cleaned immediately with acetone while the adhesive is still wet.
- i. Fold/maneuver the FB membrane into the wet adhesive, (approximate open time for the adhesive is 5 to 10 minutes depending on environmental conditions) avoiding wrinkles or air pockets in the FB membrane.
- j. Broom the membrane into the wet adhesive and complete the bonding process by firmly pressing the bonded membrane into place with a weighted, foam covered lawn roller.
- k. Repeat the process for the remaining unbonded portion of the membrane, lapping subsequent, adjacent rolls of membrane a minimum 3 inches, ensuring proper shingling of the membrane the water along the laps.
- l. No adhesive shall be applied to the lap seam areas of the membrane. Areas contaminated with adhesive are difficult to clean, may impair proper welding of the seams and may require a membrane patch or stip.
- m. FiberTite CR-20 adhesive is designed for use only when the substrate and ambient temperatures are a minimum 40°F and rising and the chemical cylinders are at least 70°F.
- n. Do not use bad or marginal adhesives. Contact FTCS if the quality of the adhesive is suspect.

D. Peel Stops for Adhered Roofing Systems

1. Seaman Corporation's standard *Terms and Conditions* for commercial warranties list 60-mph wind velocity as the first exclusion for wind events. Perimeter assurance or restraint must be provided for any modification to the standard commercial warranty.
2. Assurance or restraint is accomplished using rows of fasteners, installed parallel to exterior roof edges at a prescribed interval and fastener spacing to create a peel stop during a significant wind event.

3. Peel stops must be mechanically attached into or through the structural decking with rows of Magnum stress plates and fasteners, (or authorized alternate) at 12 inches on center. The peel stop is sealed by heat welding a nominal 6 inch strip of membrane over the fasteners.
4. Lightweight insulating concrete is generally not considered a structural component and peel stop fastening must penetrate through the lightweight into the structural component.
5. Peel Stop(s) are only required by Seaman Corporation on adhered projects requiring peak gust wind speed warranties greater than the default 60-mph articulated in the standard commercial warranty.
6. Although not required for standard commercial warranties, it is recommended that projects subject to the possibility of a significant wind event (hurricanes) should incorporate the use of peel stops in the roof system design.
7. The following are general guidelines for the use and inclusion of peel stops in adhered FiberTite Roofing Systems. Peel stop intervals are based upon the field pressure and are as follows;
 - a. Buildings with Design Velocity Pressure less than: -45 psf (FM 1-90).
No peel stop.
 - b. Buildings with Design Velocity Pressure greater than: -45 psf (FM 1-90) but less than or equal to -52.5 (FM 1-105).
One peel stop at 3 feet from all exterior roof edges.
 - c. Buildings with Design Velocity Pressure greater than: -52.5 (FM 1-105) but less than or equal to -60 psf (FM 1-120).
One peel stop at 3 inches from all edges and the second peel stop at 6 feet from all exterior roof edges.
 - d. Buildings with Design Velocity Pressure greater than: -60 (FM 1-120) but less than or equal to -67.5 psf (FM 1-135).
One peel stop at 3 feet, a second peel stop at 6 feet and the third peel stop at 9 feet from all exterior roof edges.
 - e. Buildings with Non Class 1 decking, i.e. lightweight, wood, gypsum, and cementitious wood fiber do not default to the above requirements and require additional evaluation and engineering review by FTCS.

E. Welding

1. General

- a. All field seams exceeding 10 feet in length shall be welded with an approved automatic welder.
- b. All field seams must be clean and dry prior to initiating any field welding.
- c. Remove foreign materials from the seams (dirt, oils, etc.) with acetone or authorized alternative.
- d. Use CLEAN WHITE COTTON cloths and allow approximately five minutes for solvents to dissipate before initiating the automatic welder. Do not use denim or synthetic rags for cleaning.
- e. Contaminated areas within a membrane seam will inhibit proper welding and will require a membrane patch or strip.
- f. All welding shall be performed only by qualified personnel to ensure the quality and continuity of the weld.

2. Hot Air Hand Welding

- a. The lap or seam area of the membrane may be intermittently tack welded to hold the membrane in place.
- b. The back interior edge of the membrane shall be welded first, with a thin, continuous weld to concentrate heat along the exterior edge of the lap during the final welding pass.
- c. The nozzle of the hand held hot air welder shall be inserted into the lap at a 45° angle to the lap. Once the polymer on the material begins to flow, a hand roller shall be use to apply pressure at a right angle to the tip of the hand welder. Properly welded seams shall utilize a 1.5 inch wide nozzle, to create a homogeneous weld, a minimum of 1.5 inches in width.
- d. Smaller nozzles may be used for corners, and other field detailing, maintaining a minimum 1 inch weld.

3. Automatic Hot Air Machine Welding

- a. Proper welding of the FiberTite Membrane can be achieved with a variety of automatic welding equipment. Contact FTCS for specific recommendations.
- b. Follow all manufacturers' instructions for the safe operation of the automatic welder.
- c. Follow local code requirements for electric supply, grounding and surge protection.
- d. The use of a dedicated, portable generator is highly recommended to ensure a consistent electrical supply, without fluctuations that can interfere with weld consistency.
- e. Properly welded seams shall utilize a 1.5 inch wide nozzle, to create a homogeneous weld, a minimum of 1.5 inches in width.

F. Inspection

- 1. The job foreman and/or supervisor shall initiate daily inspections of all completed work which shall include, but is not limited to the probing of all field welding with a dull pointed

- instrument to assure the quality of the application and ensure that any equipment or operator deficiencies are immediately resolved.
2. Ensure that all aspects of the installation (sheet layout, attachment, welding, flashing details, etc.) are in strict accordance with the most current FiberTite Roofing Systems Specifications and Details.
 3. Excessive patching of field seams because of inexperienced or poor workmanship will not be accepted at time of FINAL INSPECTION FOR WARRANTY ACCEPTANCE.
 4. Any deviation from preapproved specifications and/or details requires written authorization from the FTCS prior to application to avoid any warranty disqualification.
 5. It is the contractor, job foreman, and supervisor and/or quality control personnel's responsibility to perform a final self inspection on all seams prior to requesting the inspection for warranty issuance by the FTCS.

G. T-Joint Cover Installation

1. Installation of T-Joint Covers is mandatory on all FiberTite Membrane Systems greater than nominal 50 mil, vegetated roofs, ballast roofs or where T-Joints have not been properly sealed to exhibit a minimum 1.5" defined crease along the T-Joint.
2. Install T-Joint Covers, centered and aligned so edges are parallel to roof system seams.
3. The T-Joint Cover shall be 100% welded.

PART 13 - FLASHING

- A. Clean all vents, pipes, conduits, tubes, walls, and stacks to bare metal. All protrusions must be properly secured to the roof deck with approved fasteners. Remove and discard all lead, pipes and drain flashing. Flash all penetrations according to approved details.
- B. Remove all loose and/or deteriorated cant strips and flashings.
- C. Flash all curbs, parapets and interior walls in strict accordance with approved FiberTite details.
- D. All flashing shall be adhered to properly prepared, approved substrate(s) with FTR-190e adhesive or FTR-201 mastic applied in sufficient quantity to ensure total adhesion.
- E. The base flange of all membrane flashing shall extend out on to the plane of the deck, beyond the wood nailers to a maximum width of 8 inches.
- F. Vertical flashing shall be terminated no less than 8 inches above the plane of the deck with approved termination bar and counter-flashing or metal cap flashing.

- G. When using FTR-201 as the adhesive, vertical wall flashing termination shall not exceed 40 inches without supplemental mechanical attachment of the flashing between the deck and the termination point of the flashing.
- H. Complete all inside and outside corner flashing details with FiberTite pre-formed corners or an approved field fabrication detail.
- I. Probe all seams with a dull, pointed probe to ensure the weld has created a homogeneous bond.
- J. Install penetration accessories in strict accordance with approved details. Ensure penetration accessories have not impeded in any way the working specification. (Refer to the related trade for the technical specification).

PART 14 - METAL FLASHING

- A. All perimeter edge details are to be fabricated from FiberClad Metal or utilize a prefabricated FiberTite Fascia System.
- B. Ensure all fascias extend a minimum of 2 inches lower than the bottom of the wood nailers.
- C. Fasten all metal flashing to wood nailers or approved substrate with approved fasteners 8 inches on center.
- D. Break and install FiberClad metal in accordance with approved details, ensuring proper attachment, maintaining 0.5 inch expansion joints and the installation of a minimum 2 inch bond breaker tape prior to sealing the joint.
- E. Solidly weld FiberClad expansion joints with a 6 inch strip of FiberTite membrane welded to the FiberClad, covering the bond breaker tape (cover plates are optional).
- F. Roof Drains
 - 1. Flash all roof drains in accordance with FiberTite roof drain details.
 - 2. Replace all worn or broken parts that may cut the FiberTite membrane or prevent a watertight seal. This includes the clamping ring and strainer basket.
 - 3. Replace all drain bolts or clamps used to hold the drain compression ring to the drain bowl.
 - 4. FiberTite non-reinforced 60-mil membrane shall be used for flashing the drain assembly. Drain assemblies and basins or sumps must be free of any asphalt or coal tar pitch residue prior to installation.
 - 5. The drain target sheet should be sized and installed to provide for a minimum of 12 inches of exposed 60-mil on all sides of the drain.
- G. Pitch Pans

1. EVERY REASONABLE effort shall be made to eliminate the need for pitch pans including the removal of all existing pans. Contact FTCS for specific design alternatives and recommendations.
2. In the event of no alternative, fabricate pitch pans from Fiber Clad metal, installed in accordance with FiberTite details, ensuring proper attachment, maintaining a minimum of 2 inch clearance around the penetration.
3. Pitch Pans shall be filled with non-shrinking grout to within 1 inch of the top of the pan. Allow the grout to dry and fill remainder of the pan with FTR-SLS pourable sealant.
4. Pitch Pans and the sealant will require periodic maintenance by the building owner's maintenance personnel.

PART 15 - EXPANSION JOINTS

- A. Flash all expansion joints in accordance with authorized details. Fasten all expansion joint material according to FiberTite specifications. Ensure the expansion material has sufficient material to expand to the widest point in expansion without causing undue stress on the expansion joint material.
- B. If the expansion joint is a preformed system, the manufacturer, description and a drawing illustrating the method of installation must be included when the (FTR-PIN) is submitted.

PART 16 - SEALANTS

- A. Apply authorized sealant(s) to all surface mounted reglets and per project requirements. Sealant(s) are to shed water. Follow all manufacturer's instructions and installation guides.
- B. Use primer when recommended by the manufacturer.
- C. Sealants will require periodic maintenance by the building owner's maintenance personnel.

PART 17 - TEMPORARY SEALS

- A. At the end of each working day or at the sign of rain, install temporary, 100% watertight seal(s) where the completed new roofing adjoins the uncovered deck or existing roof surface.
- B. The authorized roofing contractor shall create and maintain the temporary seal in such a manner to prevent water from traveling beneath the new and/or existing roof system.
- C. The use of plastic roofing cement is permissible when sealing to an existing built up roof.
- D. If water is allowed to enter beneath the newly completed roofing, the affected area(s) shall be removed and replaced at no additional expense to the building owner.
- E. Prior to the commencement of work, cut out and remove all contaminated membrane, insulation, roof cement or sealant and properly dispose of off site.

PART 18 - WALKWAYS

- A. FiberTite walkways and protection pads shall be installed at staging areas for roof top equipment maintenance or areas subject to regular foot traffic.
- B. Walkway Installation
 - 1. Roofing membrane to receive walkway material shall be clean and dry.
 - 2. Cut and position the FiberTite walkway material as directed by the specifications or agreement.
 - 3. Hot air weld the entire perimeter of the walk way to the previously cleaned FiberTite roofing membrane. Avoid excessive heating of the walk way material to prevent scorching the underlying roofing membrane.
- C. Protection Pad Installation
 - 1. Roofing membrane to receive protection pad material shall be clean and dry.
 - 2. Prior to installing the FiberTite protection pads (0.25" x 2' x 4'), weld a 6" x 6" strip of FiberTite membrane to each of the four corners of the back side of the pad. Position the strips in such a way that they overhang the edge of the pad a minimum of 2 inches around the 90° corner.
 - 3. Position the FiberTite protection pads as directed by the specifications or agreement and weld the visible portion of the previously applied stripping to the FiberTite roofing membrane.

PART 19 - COMPLETION

- A. Remove any and all debris, excess materials and scrap of any kind from the roof and surrounding premises prior to demobilization.
- B. Inspect all field welds, detailing and terminations to ensure a 100% the watertight installation.

PART 20 - WARRANTY INSPECTION

- A. Upon completion of the project, the authorized roofing contractor shall complete and submit the FiberTite Notice of Completion to FTCS.
- B. Upon receipt of the notice of completion, a FTCS representative will schedule an inspection with a representative of the authorized roofing contractor to thoroughly review the installation and verify compliance with Seaman Corporation specifications.
- C. Any corrections or modifications necessary for compliance with the specifications and acceptance for warranty (punch list) will be noted on the Final Inspection for Warranty Form.

- D. Upon completion of all punch list items and final acceptance of the installation, a warranty as authorized by the approved Seaman Corporation/FiberTite Pre-Installation Notice will be issued.

END OF SECTION

THIS PAGE LEFT BLANK

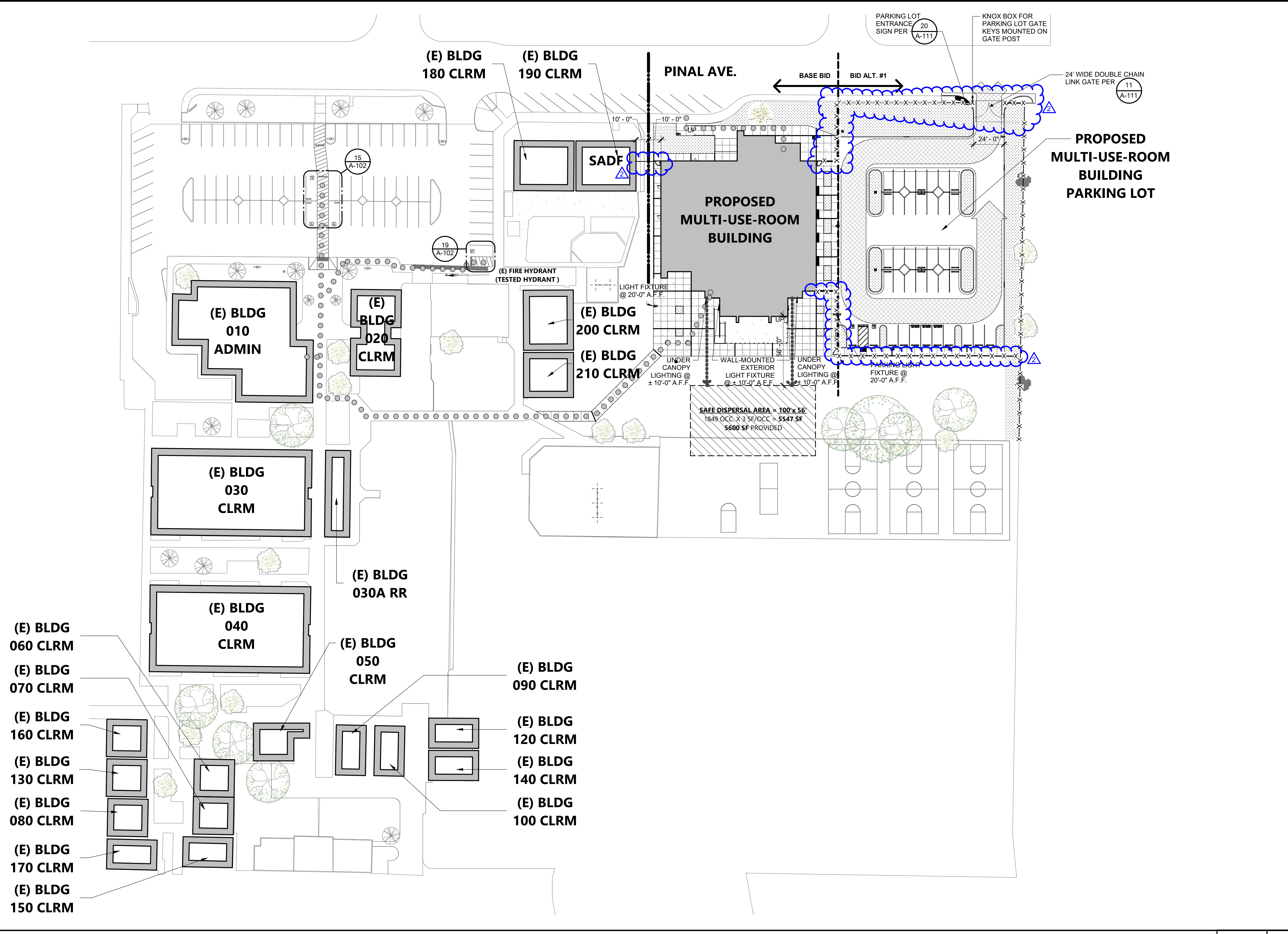

LEGEND

- ASSUMED PROPERTY LINE
- PROJECT BUILDING
- (E) BUILDING
- FIRE APPARATUS ACCESS LANE, MIN. 20FT WIDE
- PATH OF TRAVEL (P.O.T.)
 - AS INDICATED, IS A COMMON BARRIER FREE ACCESS ROUTE
 - IS AT LEAST 48" WIDE
 - NO ABRUPT VERTICAL CHANGES EXCEEDING 1/2" BEVELED AT 1:2 MAXIMUM SLOPE, EXCEPT THAT LEVEL CHANGES DO NOT EXCEED 1/4" VERTICAL
 - THE PATH SURFACE IS SLIP RESISTANT, STABLE, FIRM, AND SMOOTH.
 - PASSING SPACES (11B-403.2) NOT MORE THAN 400' APART
 - THE CROSS-SLOPE DOES NOT EXCEED 2% AND SLOPE IN THE DIRECTION OF TRAVEL IS LESS THAN 5% UNLESS OTHERWISE INDICATED.
 - (POT) SHALL BE MAINTAINED FREE OF OVERHANGING OBSTRUCTIONS TO 80" MINIMUM (11B-307.4) AND PROTRUDING OBJECTS GREATER THAN 4" PROJECTION FROM WALL AND ABOVE 27" AND LESS THAN 80" (11B-307).
 - ARCHITECT SHALL VERIFY PATH OF TRAVEL CONFORMS WITH THE ABOVE.
 - DESIGN PROFESSIONAL IN GENERAL RESPONSIBLE CHARGE STATEMENT: THE P.O.T. IDENTIFIED IN THESE CONSTRUCTION DOCUMENTS MEETS THE REQUIREMENTS OF THE CURRENT APPLICABLE CALIFORNIA BUILDING CODE (CBC) ACCESSIBILITY PROVISIONS FOR PATH OF TRAVEL REQUIREMENTS FOR ALTERATION, ADDITIONS, AND STRUCTURAL REPAIRS AS PART OF THE DESIGN OF THIS PROJECT. THE P.O.T. WAS EXAMINED AND ANY ELEMENTS, COMPONENTS, OR PORTIONS OF THE P.O.T. THAT WERE DETERMINED TO BE NON-COMPLIANT WITH CBC HAVE BEEN IDENTIFIED AND THE CORRECTIVE WORK NECESSARY TO BRING THEM INTO COMPLIANCE HAS BEEN INCLUDED WITHIN THE SCOPE OF THE PROJECT'S WORK THROUGH DETAILS, DRAWINGS AND SPECIFICATIONS INCORPORATED INTO THESE CONSTRUCTION DOCUMENTS. ANY NON-COMPLIANT ELEMENTS, COMPONENTS, OR PORTIONS OF THE P.O.T. THAT WILL NOT BE CORRECTED BY THIS PROJECT BASED ON VALUATION THRESHOLD LIMITATIONS OR A FINDING OF UNREASONABLE HARDSHIP ARE INDICATED IN THESE CONSTRUCTION DOCUMENTS.
 - DURING CONSTRUCTION, IF P.O.T. ITEMS WITHIN THE SCOPE OF THE PROJECT REPRESENTED AS CBC COMPLIANT ARE FOUND TO BE NON-COMPLIANT BEYOND REASONABLE CONSTRUCTION TOLERANCES, THE ITEMS SHALL BE BROUGHT INTO COMPLIANCE WITH THE CBC AS PART OF THE PROJECT BY MEANS OF A CONSTRUCTION CHANGE DOCUMENT.
- CHAIN LINK GATE, SWINGING TYPE
 - ALLOWS MANUAL OPERATION BY ONE PERSON
 - SHALL BE MAINTAINED IN AN OPERATIVE CONDITION AT ALL TIMES AND REPLACED OR REPAIRED WHEN DEFECTIVE
 - SEE 11 A-111
- FENCE LINE
- DECORATIVE FENCE LINE
- EXIT DISCHARGE PATH TO SAFE DISPERSAL AREA

FIRE FLOW

REQUIRED FIRE FLOW PER 2019 CFC APPENDIX BB	TYPE V-B @ 14.618 SF	*3,250 GPM / 1,500 GPM WITH REDUCTION PER CFC BB105.1
PROVIDED FIRE FLOW		*3,000 GPM

*MEASURED AT 20 PSI

Golden State Water Company
A Division of American States Water Company

08/05/2021

Hazel Cruz
19six Architects
560 Higuera St., Suite C
San Luis Obispo, CA 93401

Re: Orcutt Academy High School – 610 Pinal Avenue

This letter is in response to your request for a fire flow report for Orcutt Academy High School located at 610 Pinal Avenue. The request is for the fire hydrant adjacent to the school, FH #802 located at 805 Pinal Avenue. We have performed a physical fire flow and hydraulic model emulation of the water system to determine the static pressure and flow availability at 20 psi residual pressure. The physical fire flow represents a moment in time that may or may not reflect actual fire flow availability depending on the time of day fire flow is required. In light of this, this report provides the hydraulic model emulation of the available flow based on our maximum day demand model. The results based on the hydraulic model emulation are as follows:

FH #802
Static Pressure = 69 psi
Flow @ 20 psi = 3000 GPM
Capacity Duration > 4 hrs

Sincerely,
Joshua P. Alvidrez
Operations Engineer – Coastal District
Golden State Water Company

196 ARCHITECTS

560 HIGUERA STREET, SUITE C
SAN LUIS OBISPO, CA 93401
TEL (805) 476-0399

- CONSULTANTS
- CIVIL ENGINEER
STANTEC CONSULTING SERVICES INC.
111 East Victoria Street
Santa Barbara, CA 93101
TEL (805) 680-6830
 - LANDSCAPE ARCHITECT
DASIS ASSOCIATES
3427 Miguelito Court
San Luis Obispo, CA 93401
TEL (805) 541-4509
 - STRUCTURAL ENGINEER
STORK, WOLFE & ASSOCIATES
555 Chorro Street, Suite A1
San Luis Obispo, CA 93405
TEL (805) 548-8500
 - MECHANICAL ENGINEER
BMA MECHANICAL +
100 Cross Street, Suite 204
San Luis Obispo, CA 93401
TEL (805) 544-4269
 - ELECTRICAL ENGINEER
THOMA ENGINEERING
3562 Empeo, Suite C
San Luis Obispo, CA 93406
TEL (805) 543-3850
 - FIRE PROTECTION ENGINEER
BMA MECHANICAL +
100 Cross Street, Suite 204
San Luis Obispo, CA 93401
TEL (805) 544-42-69

ARCHITECT STAMP
CONSULTANT STAMP

ARCHITECT: ALICE CRUZ
C-22474
EXPIRES 03-31-25
STATE OF CALIFORNIA

REVISIONS

NO.	DATE	DESCRIPTION
1	04-19-2022	ADDENDUM 1
A	05-19-2022	ADDENDUM A
B	05-20-2022	ADDENDUM B
2	05-23-2022	ADDENDUM 5

THE ARCHITECT DOES NOT REPRESENT THAT THESE PLANS OR THE SPECIFICATIONS ARE SUITABLE FOR ANY SITE OTHER THAN THE ONE FOR WHICH THEY WERE SPECIFICALLY PREPARED. THE ARCHITECT DISCLAIMS RESPONSIBILITY FOR THESE PLANS AND SPECIFICATIONS IF THEY ARE USED IN WHOLE OR IN PART AT ANY OTHER SITE.

PROJECT OWNER & TITLE
ORCUTT UNION SCHOOL DISTRICT
500 Dyer Street
Orcutt, CA 93455

ORCUTT ACADEMY HS MUR BUILDING
610 Pinal Avenue
Orcutt, CA 93455

SHEET TITLE
CODE SITE PLAN

DRAWN BY: FC, HC
JOB NUMBER: 20179.01

SHEET NO.
G-101
DATE: APRIL 5, 2022

MUR BLDG PARKING LOT ANALYSIS

TOTAL NUMBER OF STALLS	NUMBER OF ACC. STALLS REQUIRED	NUMBER OF ACC. STALLS PROVIDED	NUMBER OF VAN ACC. STALLS REQUIRED	NUMBER OF VAN ACC. STALLS PROVIDED
39	2	2	1	1

EXISTING PARKING LOT ANALYSIS

TOTAL NUMBER OF STALLS	NUMBER OF ACC. STALLS REQUIRED	NUMBER OF ACC. STALLS PROVIDED	NUMBER OF VAN ACC. STALLS REQUIRED	NUMBER OF VAN ACC. STALLS PROVIDED
80	4	4	1	1

BUILDING INFORMATION

BLDG NO.	DESCRIPTION	D.S.A. APPLICATION # (YEAR)	CERTIFICATION # (DATE)
010	ADMIN / MULTI-USE	A# 18140 (1959)	#1 (8/21/1960)
010	ADMIN / MULTI-USE	A# 49494 (1988)	#1 (7/21/1989)
010	ADMIN / MULTI-USE	A# 03-102273 (2001)	#1 (5/23/2006)
010	ADMIN / MULTI-USE	A# 03-104880 (2005)	#1 (4/19/2006)
010	ADMIN / MULTI-USE	A# 03-115040 (2014)	#1 (1/20/2015)
020	CLASSROOM/SERVING LINE	A# 18140 (1959)	#1 (8/21/1960)
020	CLASSROOM/SERVING LINE	A# 03-102273 (2001)	#1 (5/23/2006)
020	CLASSROOM/SERVING LINE	A# 03-113888 (2011)	#1 (2/01/2013)
030	CLASSROOMS	A# 18140 (1959)	#1 (8/21/1960)
030	CLASSROOMS	A# 03-102273 (2001)	#1 (5/23/2006)
030A	RESTROOMS	A# 03-102273 (2001)	#1 (5/23/2006)
030A	RESTROOMS	A# 03-113888 (2011)	#1 (2/01/2013)
040	CLASSROOMS	A# 18140 (1959)	#1 (8/21/1960)
040	CLASSROOMS	A# 03-102273 (2001)	#1 (5/23/2006)
050	CLASSROOMS	A# 20918 (1961)	#1 (1/07/1963)
050	CLASSROOMS	A# 03-102273 (2001)	#1 (5/23/2006)
060	CLASSROOM	A# 49057 (1987)	#2 (11/27/2018)
070	CLASSROOM	A# 49057 (1987)	#2 (11/27/2018)
080	CLASSROOM	A# 50001 (1987)	#2 (2/25/1998) (COND./SSF)
090	CLASSROOM	A# 49412 (1986)	#1 (7/08/1993)
100	CLASSROOM	A# 51829 (1988)	#1 (4/03/1995)
120	CLASSROOM	A# 62585 (1996)	#1 (8/25/2004)
130	CLASSROOM	A# 68481 (1997)	#1 (3-03-2004)
140	CLASSROOM	A# 69117 (1997)	#1 (10/30/2001)
150	CLASSROOM	A# 69620 (1997)	#1 (6/07/2000)
160	CLASSROOM	A# 03-100712 (1998)	#1 (12/09/2002)
170	CLASSROOM	A# 03-106578 (2002)	#1 (4/21/2004)
180	CLASSROOM	A# 03-104482 (2000)	#1 (3/16/2005)
190	CLASSROOM	A# 03-104482 (2000)	#1 (3/16/2005)
200	MULTI-USE	A# 03-106546 (2002)	#1 (4/06/2004)
210	CLASSROOM	A# 03-106658 (2004)	#1 (5/24/2005)

DSA FORM 810

810

FIRE & LIFE SAFETY SITE CONDITIONS SUBMITTAL

Division of the State Architect (DSA) documents referenced within this publication are available on the DSA Forms or DSA Publications webpages.

To facilitate the Division of the State Architect's (DSA) fire and life safety plan review of project site conditions, DSA requires the design professional to provide the following information at time of project submittal for projects consisting of construction of a new campus, construction of new building(s), additions to existing buildings, and for site alternate design means for fire department emergency vehicle access, and fire suppression water supply.

Information associated with compliance items 1 through 3 below is to be provided for all project types indicated above. Information associated with items 4 through 7 is to be completed when an alternate means is utilized. Acknowledgement by the school district and signature from the Local Fire Authority (LFA) is only required when an alternate design means is being requested.

The Project Information and Fire & Life Safety Information sections are to be completed for all projects and imaged onto the fire access site plan. When an alternate design/means is proposed, all sections on pages 1 and 2 are to be completed and imaged on the fire access site plan.

For additional information refer to the instructions at the end of this form and DSA Policy PL 09-01: Fire Flow for Buildings.

PROJECT INFORMATION			
School District/Owner:	Orcutt Union School District		
Project Name/School:	Orcutt Academy High School Multi-Use Room Building		
Project Address:	610 Pinal Ave., Orcutt, CA 93455		

FIRE & LIFE SAFETY INFORMATION			
1. Has a fire hydrant flow test been performed within the past 12 months? (If yes, provide a copy of the test data.)	Yes <input checked="" type="checkbox"/>	No <input type="checkbox"/>	
2. Was the fire hydrant water flow test performed as part of this LFA review?	Yes <input checked="" type="checkbox"/>	No <input type="checkbox"/>	
3. Is the project located within a designated fire hazard severity zone (FHSZ) as established by Cal-Fire? (If yes, indicate FHSZ classification below.)	Yes <input checked="" type="checkbox"/>	No <input type="checkbox"/>	
Refer to the following website for FHSZ locations: http://www.cal-fire.ca.gov/FHSZ/	Moderate <input type="checkbox"/>	High <input type="checkbox"/>	Very High <input type="checkbox"/>
Wildland Interface Area (WIFA) (If any designations are checked, project design must meet the requirements of CBC Chapter 7A.)			WIFA <input type="checkbox"/>

DATE PLOTTED: 5/20/2022 11:52:14 AM FILE LOCATION: C:\Users\mbiancane\Documents\20179_01_OUSD_OAHS_MUR_A20_V2_Constructibility_Report_MBIancane18sk.rvt

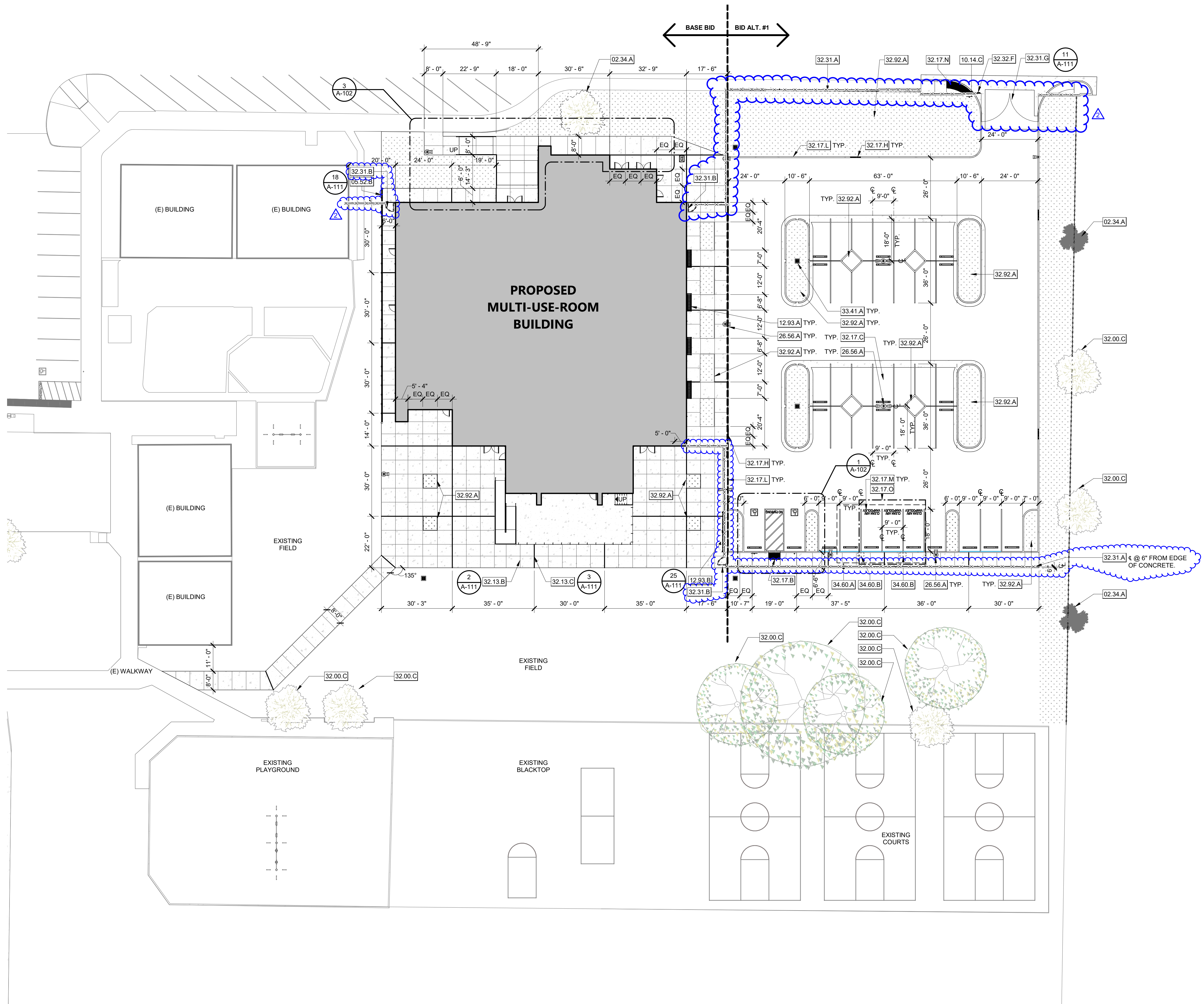

OVERALL SITE PLAN 1" = 20'-0" 1

KEYNOTES

- 02.34.A EXISTING TREE TO BE REMOVED
- 05.52.B 1-1/2" DIA. SCH. 40 GUARDRAIL
- 10.14.C PARKING LOT ENTRANCE SIGN PER 20A-111
- 12.93.A SITE SEATING AND TABLES
- 12.93.B BIKE RACK
- 26.56.A LIGHT STANDARDS PER ELECTRICAL DRAWINGS.
- 32.00.C (E) TREE
- 32.13.B CONTROL JOINTS AT 6'-0" O.C. OR AS SHOWN ON THE PLANS
- 32.13.C EXPANSION JOINTS AT 30'-0" O.C. OR AS SHOWN ON THE PLANS
- 32.17.B 36" WIDE TRUNCATED DOMES BAND
- 32.17.C 4" WIDE WHITE STRIPING
- 32.17.H 4" TALL HIGHWAY WHITE LETTERING WITH A STROKE OF .75" MIN. TO READ "NO PARKING - FIRE LANE" AT 100' O.C.
- 32.17.L PAINT CURB RED
- 32.17.M 12" "CLEAN AIR/MAN/POOL/EV." PAINT, IN THE PAINT USED FOR STALL STRIPING, SUCH THAT THE LOWER EDGE OF THE LAST WORD ALIGNS WITH THE END OF THE STALL STRIPING.
- 32.17.N TRUNCATED DOMES. SEE CIVIL DRAWINGS.
- 32.17.O DESIGNATED PARKING FOR CLEAN AIR VEHICLES.
- 32.31.A 6'-0" TALL CHAIN LINK FENCE
- 32.31.B SINGLE 3'-0" WIDE CHAIN LINK GATE
- 32.31.G 24'-0" WIDE DOUBLE CHAIN LINK GATE
- 32.32.F KNOX BOX FOR PARKING LOT GATE KEYS MOUNTED ON GATE POST
- 32.92.A LANDSCAPE AREA. REFER TO LANDSCAPE DRAWINGS
- 33.41.A STORM DRAIN INLET GRATE & BOX. REFER TO CIVIL
- 34.60.A FUTURE EV CHARGING STATIONS.
- 34.60.B FUTURE EV CHARGER.

SITE PLAN GENERAL NOTES

- SEE MECHANICAL, ELECTRICAL, AND CIVIL DRAWINGS FOR UTILITIES.

FUTURE EV CHARGING STATIONS ANALYSIS*

TOTAL NUMBER OF STALLS	NUMBER OF FUTURE EV CHARGING SPACES REQUIRED	NUMBER OF FUTURE EV CHARGING SPACES PROVIDED
39	4	4

*PER CALGREEN TABLE 5.106.5.3.3

AGENCY APPROVAL DS&E 03-121912

560 HIGUERA STREET, SUITE C
SAN LUIS OBISPO, CA 93401
TEL (805) 476-0399

CONSULTANTS

- CIVIL ENGINEER
STANTEC CONSULTING SERVICES INC.
111 East Victoria Street
Santa Barbara, CA 93101
TEL (805) 680-6830
- LANDSCAPE ARCHITECT
OASIS ASSOCIATES
3427 Miguelito Court
San Luis Obispo, CA 93401
TEL (805) 541-4509
- STRUCTURAL ENGINEER
STORK, WOLFE & ASSOCIATES
555 Chorro Street, Suite A1
San Luis Obispo, CA 93405
TEL (805) 548-8500
- MECHANICAL ENGINEER
BMA MECHANICAL +
100 Cross Street, Suite 204
San Luis Obispo, CA 93401
TEL (805) 544-4269
- ELECTRICAL ENGINEER
THOMA ENGINEERING
3562 Empleo, Suite C
San Luis Obispo, CA 93406
TEL (805) 543-3850
- FIRE PROTECTION ENGINEER
BMA MECHANICAL +
100 Cross Street, Suite 204
San Luis Obispo, CA 93401
TEL (805) 544-42-69

ARCHITECT STAMP	CONSULTANT STAMP

REVISIONS

NO.	DATE	DESCRIPTION
1	04-19-2022	Addendum 1
B	05-20-2022	ADDENDUM B
2	05-23-2022	Addendum 5

THE ARCHITECT DOES NOT REPRESENT THAT THESE PLANS OR THE SPECIFICATIONS ARE SUITABLE FOR ANY SITE OTHER THAN THE ONE FOR WHICH THEY WERE SPECIFICALLY PREPARED. THE ARCHITECT DISCLAIMS RESPONSIBILITY FOR THESE PLANS AND SPECIFICATIONS IF THEY ARE USED IN WHOLE OR IN PART AT ANY OTHER SITE.

PROJECT OWNER & TITLE

ORCUTT UNION SCHOOL DISTRICT
500 Dyer Street
Orcutt, CA 93455

ORCUTT ACADEMY HS MUR BUILDING
610 Pinal Avenue
Orcutt, CA 93455

SHEET TITLE

SITE PLAN

DRAWN BY: FC, HC JOB NUMBER: 20179.01

SHEET NO.

A-101

DATE: APRIL 5, 2022

DATE PLOTTED: 5/20/2022 11:36:43 AM FILE LOCATION: C:\Users\mbiancane\Documents\20179_01_OUSD_OAHS_MUR_A20_V2_ConstructibilityReport_MBIancane18sk.rvt

- ### KEYNOTES
- 03.00.A (E) CONCRETE PAD TO REMAIN
 - 05.52.A 1-1/2" DIA. SCH. 40 HANDRAIL
 - 07.62.B 3" DIA. DOWNSPOUT, PER PLUMBING SPECIFICATIONS. CONNECT TO STORM DRAIN SYSTEM.
 - 10.00.B (E) VAN ACCESSIBLE STALL SIGN
 - 10.00.C (E) ACCESSIBLE STALL SIGN
 - 10.14.D REGULAR ACCESSIBLE STALL SIGN
 - 26.56.A LIGHT STANDARDS PER ELECTRICAL DRAWINGS.
 - 32.00.D (E) 2" WIDE BLUE STRIPING
 - 32.00.E (E) 36" X 36" INTERNATIONAL SYMBOL OF ACCESSIBILITY
 - 32.00.F (E) 12" WHITE NO PARKING LETTERS
 - 32.00.G (E) REGULAR PARKING STALL
 - 32.00.H (E) WHEEL STOP, PAINTED BLUE.
 - 32.13.D CONCRETE CURB (& GUTTER WHERE OCCURS) IN THE AREA OF WORK, UNLESS NOTED OTHERWISE. REFER TO CIVIL.
 - 32.17.A WHEEL STOP
 - 32.17.B 36" WIDE TRUNCATED DOMES BAND
 - 32.17.D 4" WIDE BLUE STRIPING. BLUE 15090 FEDERAL STANDARD 595A
 - 32.17.F 12" WHITE "NO PARKING" LETTERS

AGENCY APPROVAL **OSAE** 03-121912



560 HIGUERA STREET, SUITE C
SAN LUIS OBISPO, CA 93401
TEL (805) 476-0399

- CONSULTANTS
- CIVIL ENGINEER
STANTEC CONSULTING SERVICES INC.
111 East Victoria Street
Santa Barbara, CA 93101
TEL (805) 680-6830
 - LANDSCAPE ARCHITECT
DASIS ASSOCIATES
3427 Miguelito Court
San Luis Obispo, CA 93401
TEL (805) 541-4509
 - STRUCTURAL ENGINEER
STORK, WOLFE & ASSOCIATES
555 Chorro Street, Suite A1
San Luis Obispo, CA 93405
TEL (805) 548-8500
 - MECHANICAL ENGINEER
BMA MECHANICAL +
100 Cross Street, Suite 204
San Luis Obispo, CA 93401
TEL (805) 544-4269
 - ELECTRICAL ENGINEER
THOMA ENGINEERING
3562 Empleo, Suite C
San Luis Obispo, CA 93406
TEL (805) 543-3850
 - FIRE PROTECTION ENGINEER
BMA MECHANICAL +
100 Cross Street, Suite 204
San Luis Obispo, CA 93401
TEL (805) 544-42-69

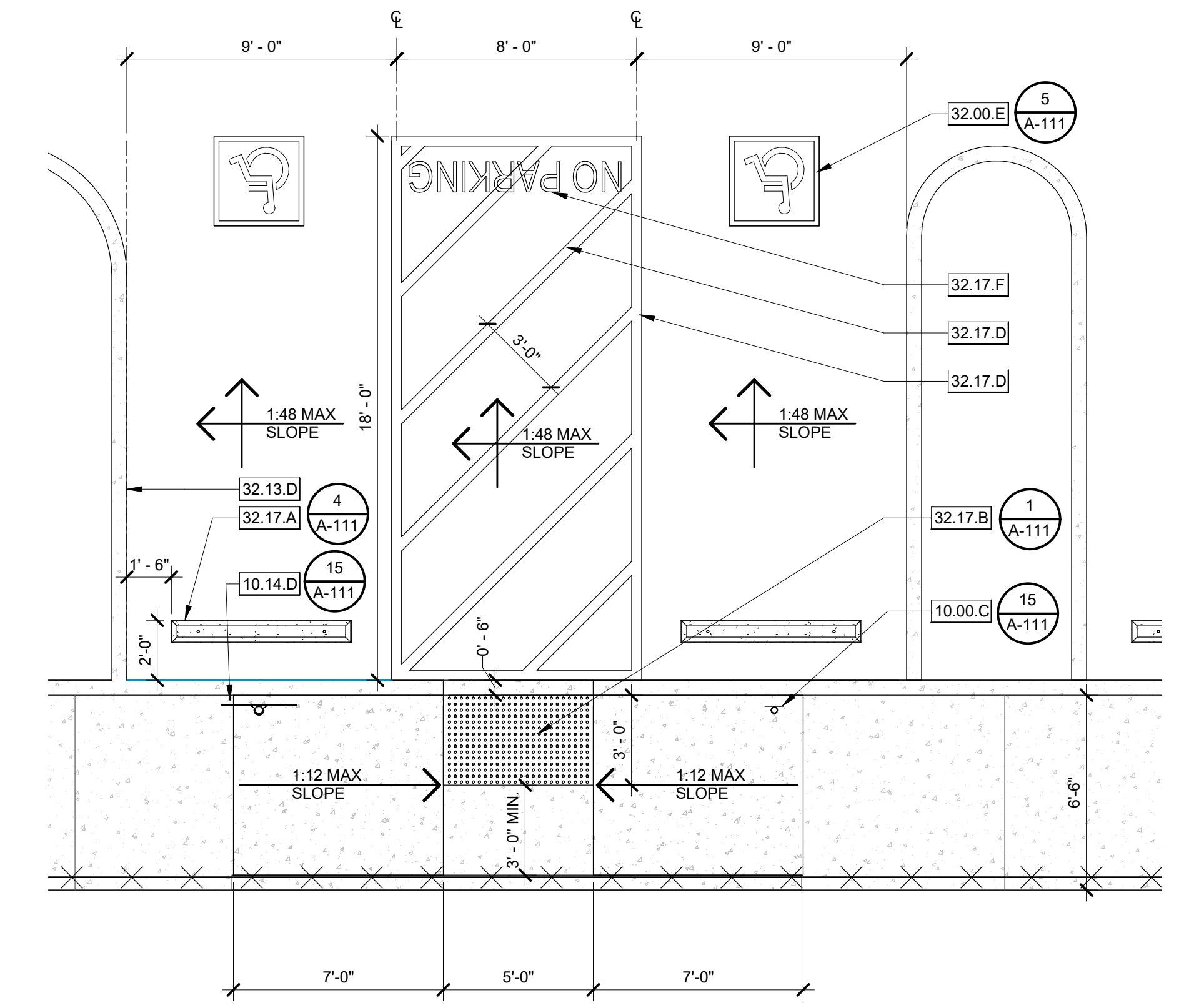
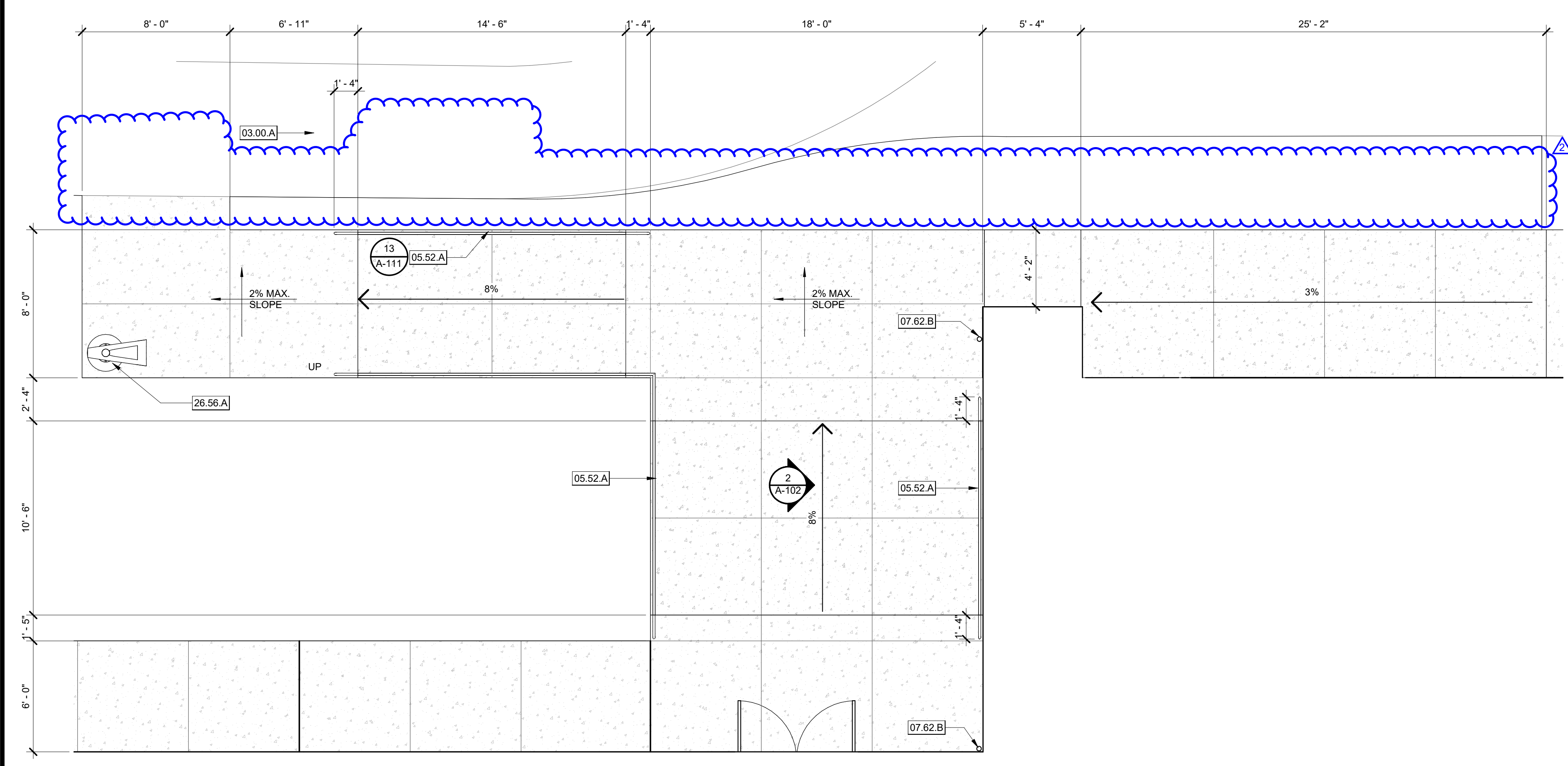

OVERALL SITE PLAN - EXTERIOR RAMP ENTRY 1/4" = 1'-0" 3

OVERALL SITE PLAN - ACCESSIBLE PARKING 1/4" = 1'-0" 1

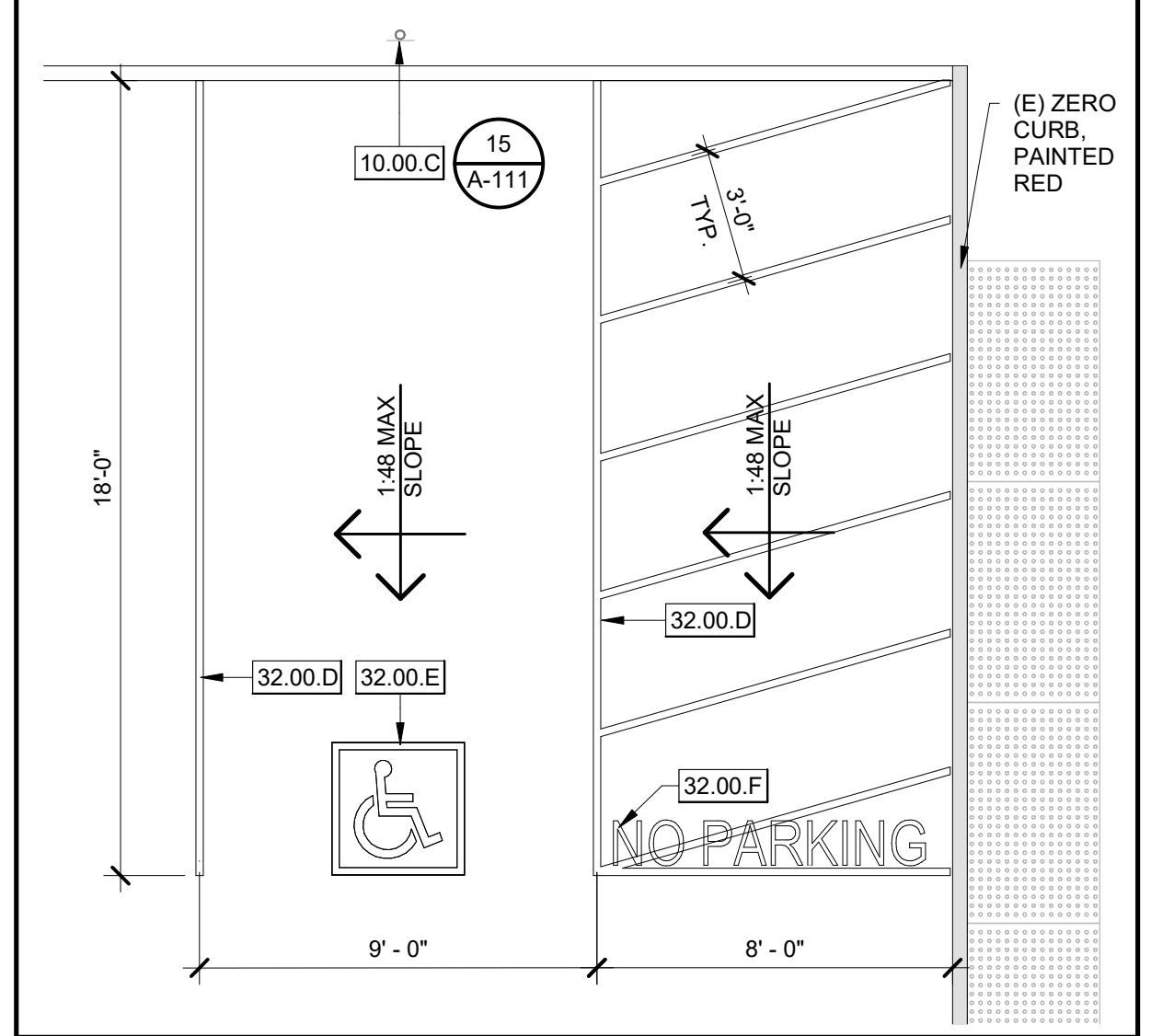

(E) ACCESSIBLE PARKING STALL 1/4" = 1'-0" 19

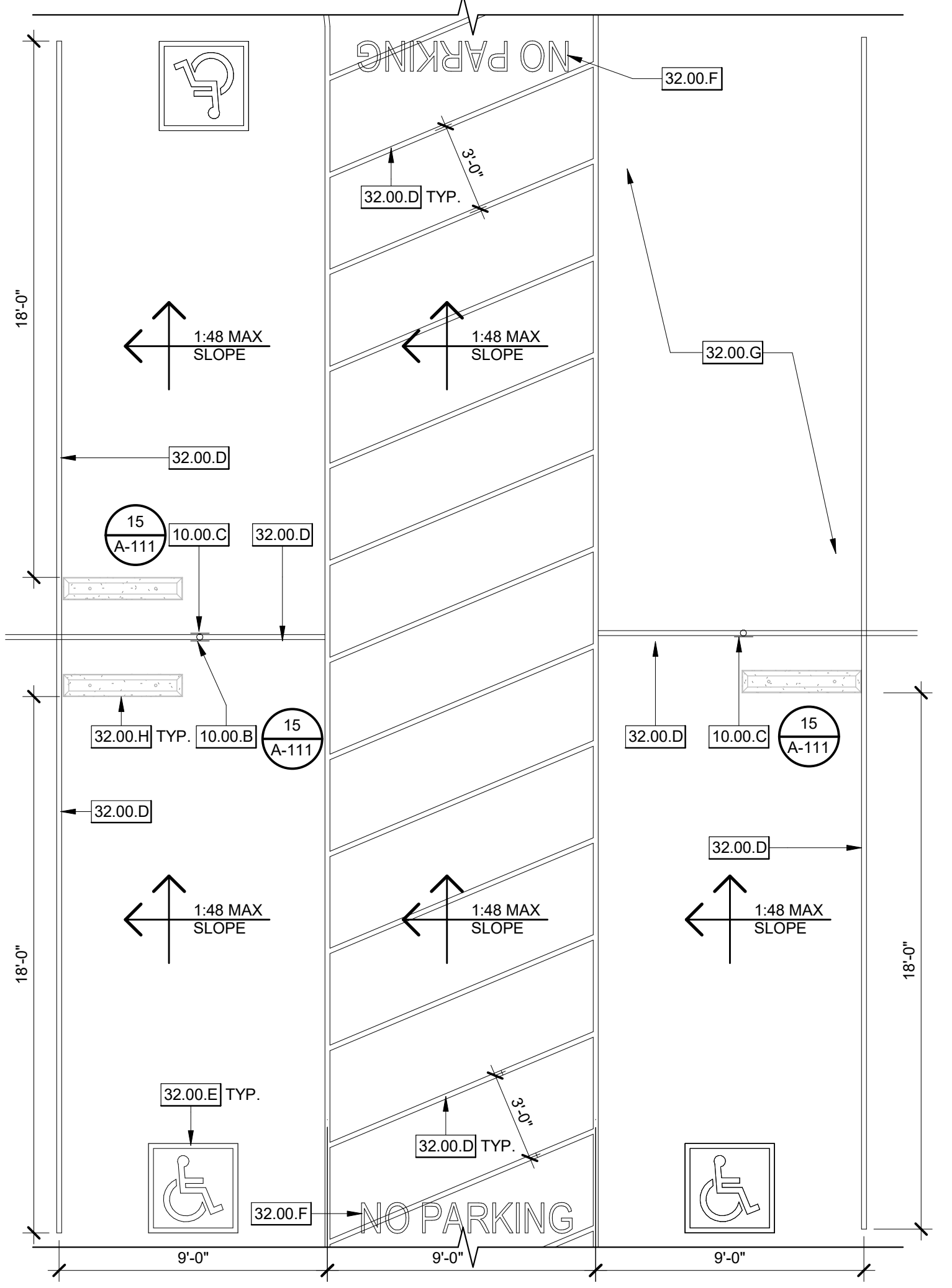

EXISTING ACCESSIBLE PARKING 1/4" = 1'-0" 15

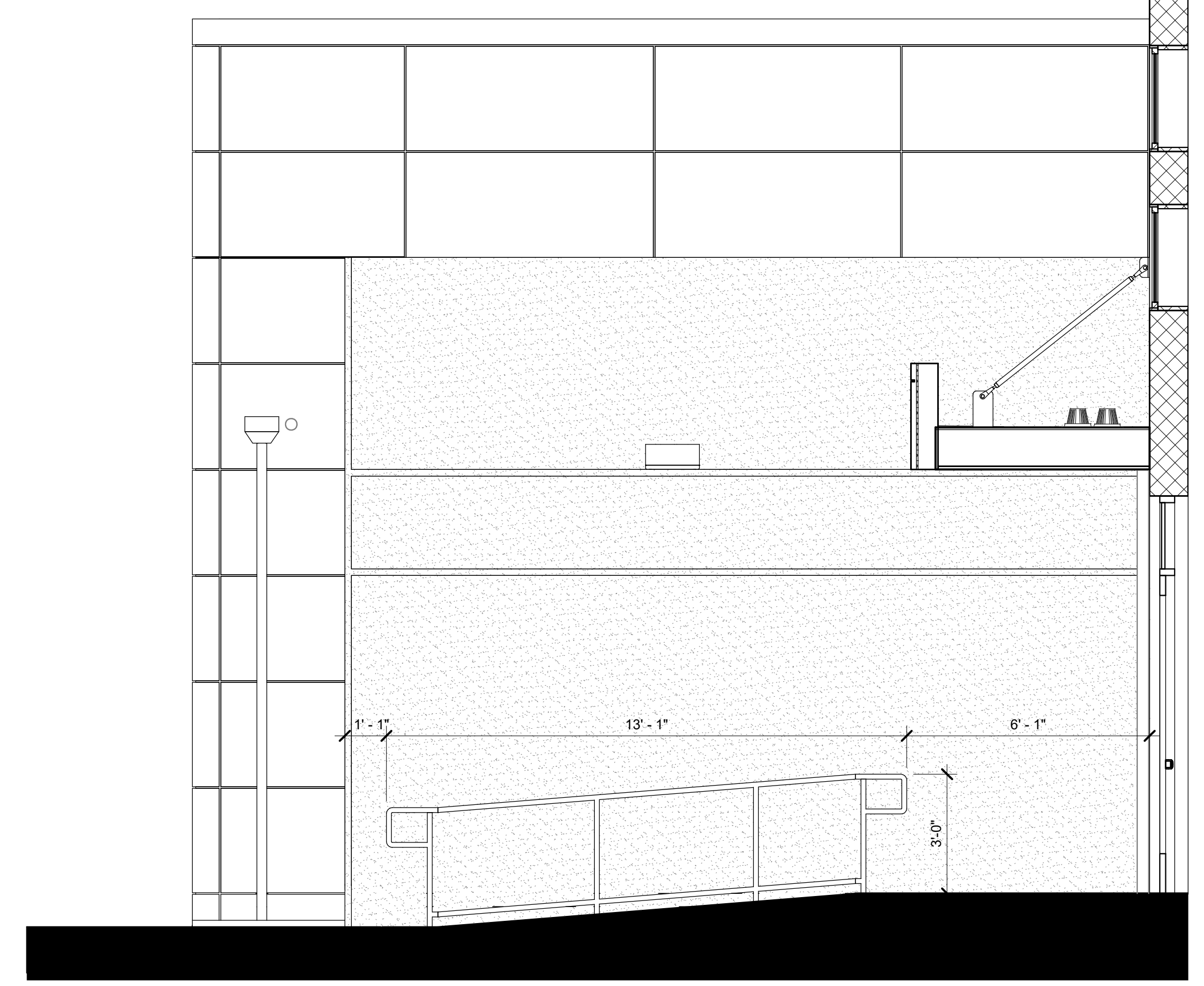

RAMP ELEVATION AT EXTERIOR RAMP ENTRY 3/8" = 1'-0" 2

ARCHITECT STAMP CONSULTANT STAMP

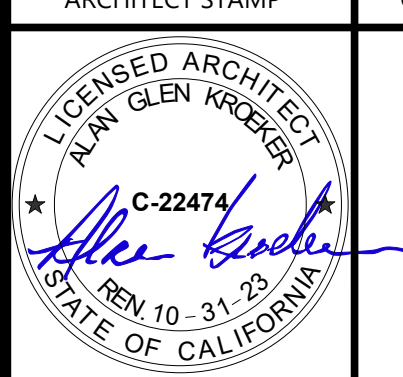

REVISIONS

NO.	DATE	DESCRIPTION
1	04-19-2022	Addendum 1
2	05-23-2022	Addendum 5

THE ARCHITECT DOES NOT REPRESENT THAT THESE PLANS OR THE SPECIFICATIONS ARE SUITABLE FOR ANY SITE OTHER THAN THE ONE FOR WHICH THEY WERE SPECIFICALLY PREPARED. THE ARCHITECT DISCLAIMS RESPONSIBILITY FOR THESE PLANS AND SPECIFICATIONS IF THEY ARE USED IN WHOLE OR IN PART AT ANY OTHER SITE.

PROJECT OWNER & TITLE
ORCUTT UNION SCHOOL DISTRICT
500 Dyer Street
Orcutt, CA 93455

ORCUTT ACADEMY HS MUR BUILDING
610 Pinal Avenue
Orcutt, CA 93455

SHEET TITLE
ENLARGED SITE PLAN

DRAWN BY: HC JOB NUMBER: 20179.01

SHEET NO.
A-102
DATE: APRIL 5, 2022

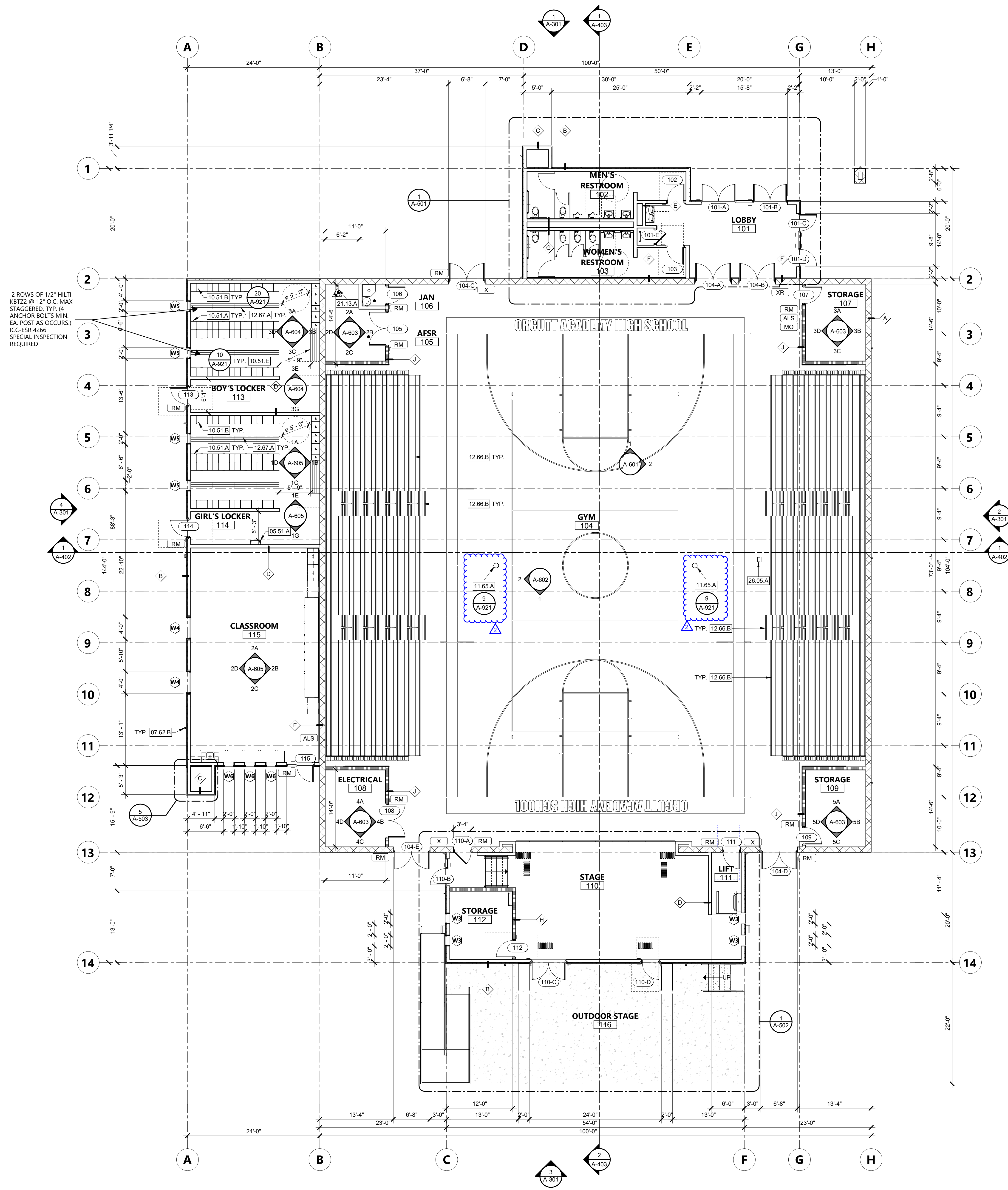

KEYNOTES

- 05.51.A ALUMINUM ACCESS LADDER WITH COVER
- 07.62.B 3" DIA. SCHEDULE 40 DOWNSPOUT, PAINTED. CONNECT TO STORM DRAIN SYSTEM.
- 10.51.A 12" WIDE X 72" TALL X 18" DEEP - 4-TIER LOCKERS
- 10.51.B 24" WIDE X 72" TALL X 18" DEEP - 2-TIER LOCKERS
- 10.51.E BENCH TO COMPLY WITH C.B.C. 11B-903
- 11.65.A VOLLEYBALL POST FLOOR SLEEVE
- 12.66.B TELESCOPING BLEACHERS AISLE
- 12.67.A BENCH
- 21.13.A AUTOMATIC FIRE SPRINKLER RISER. SEE FIRE SUPPRESSION DRAWINGS.
- 26.05.A FLOOR BOX FOR POWER, DATA AND COMMUNICATION

FLOOR PLAN LEGEND

- ROOM NAME** → ROOM NAME
 [101] → ROOM NUMBER
- ⬆️ → WALL TYPE TAG PER A-901
 - 101AA → DOOR TYPE TAG
 - ⬆️ → WINDOW TYPE TAG
 - ⬆️ → EQUIPMENT SCHEDULE
 - ⬆️ → EQUIPMENT MARK
 - RM → SIGNAGE TAG - SEE A-831 FOR SIGN DETAILS

CLEARANCE LEGEND

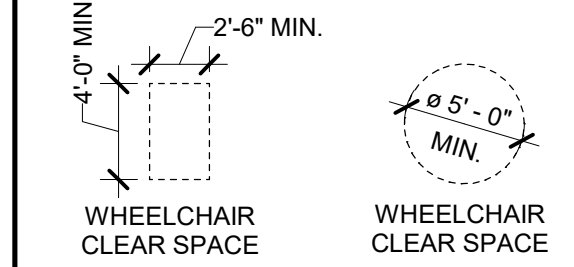

FLOOR PLAN GENERAL NOTES

1. ALL DIMENSIONS ARE FROM FACE OF STUD TO FACE OF PLYWOOD, STUD, AND CMU OR CENTERLINE OF COLUMN.
2. ALL EXPOSED STEEL TO BE GALVANIZED AND PAINTED.
3. ALL EXPOSED PIPES, STRUCTURE, AND CONDUIT TO BE PAINTED.
4. NOTE: FABRICATION AND INSTALLATION OF DEFERRED SUBMITTAL ITEMS SHALL NOT BE STARTED UNTIL CONTRACTOR'S DRAWINGS, SPECIFICATIONS AND ENGINEERING CALCULATIONS FOR THE ACTUAL SYSTEMS TO BE INSTALLED LIST OF DEFERRED SUBMITTALS ON G-011LED HAVE BEEN ACCEPTED AND SIGNED BY THE ARCHITECT OR STRUCTURAL ENGINEER AND APPROVED BY THE DSA. SEE LIST OF DEFERRED APPROVALS ON G-001

LOCKER CALCULATIONS

CALCULATIONS PER C.B.C. 11B-225.2.1 LOCKERS
 NUMBER OF LOCKERS PROVIDED: 356
 PERCENT OF LOCKERS THAT MUST BE ACCESSIBLE: 5%
 NUMBER OF ACCESSIBLE LOCKERS REQUIRED: 356*0.05 = 17.8
 NUMBER OF ACCESSIBLE LOCKERS PROVIDED: 20



ASSISTIVE LISTENING SYSTEM

- A. AN ADA COMPLIANT FM BASED ASSISTIVE LISTENING SYSTEM SHALL BE PROVIDED.
- B. LOCATION: THE ASSISTIVE LISTENING SYSTEM PROVIDED IS LIMITED TO SPECIFIC AREAS AND/OR SEATS, THESE AREAS SHALL BE WITHIN A 50-FOOT (15.24 M) VIEWING DISTANCE OF THE STAGE OR PLAYING AREA AND SHALL HAVE COMPLETE VIEW OF THE STAGE OR THE PLAYING AREA.
- C. PORTABLE ASSISTIVE-LISTENING SYSTEM WILL BE PROVIDED.

CALCULATIONS PER C.B.C. 11B-219.3 ASSISTIVE LISTENING SYSTEMS RECEIVERS

GYM (RM. 104)
 NUMBER OF SEATS/OCCUPANT LOAD: 1,658
 PERCENT OF SEATS TO REQUIRED MINIMUM NUMBER OF RECEIVERS: 4%
 NUMBER OF REQUIRED RECEIVERS: 1,658*0.04 = 67
 PERCENT OF RECEIVERS REQUIRED TO BE HEARING AID COMPATIBLE: 25%, BUT NO FEWER THAN 2
 NUMBER OF RECEIVERS REQUIRED TO BE HEARING AID COMPATIBLE: 67*0.25 = 17

CLASSROOM (RM. 115)
 NUMBER OF SEATS/OCCUPANT LOAD: 46
 PERCENT OF SEATS TO REQUIRED MINIMUM NUMBER OF RECEIVERS: 4%
 NUMBER OF REQUIRED RECEIVERS: 46*0.04 = 2
 PERCENT OF RECEIVERS REQUIRED TO BE HEARING AID COMPATIBLE: 25%, BUT NO FEWER THAN 2
 NUMBER OF RECEIVERS REQUIRED TO BE HEARING AID COMPATIBLE: 2



560 HIGUERA STREET, SUITE C
 SAN LUIS OBISPO, CA 93401
 TEL (805) 476-0399

CONSULTANTS

CIVIL ENGINEER
 STANTEC CONSULTING SERVICES INC.
 111 East Victoria Street
 Santa Barbara, CA 93101
 TEL (805) 680-6830

LANDSCAPE ARCHITECT
 OASIS ASSOCIATES
 3427 Miguelito Court
 San Luis Obispo, CA 93401
 TEL (805) 541-4509

STRUCTURAL ENGINEER
 STORK, WOLFE & ASSOCIATES
 555 Chorro Street, Suite A1
 San Luis Obispo, CA 93405
 TEL (805) 548-8500

MECHANICAL ENGINEER
 BMA MECHANICAL +
 100 Cross Street, Suite 204
 San Luis Obispo, CA 93401
 TEL (805) 544-4269

ELECTRICAL ENGINEER
 THOMA ENGINEERING
 3562 Empeo, Suite C
 San Luis Obispo, CA 93406
 TEL (805) 543-3850

FIRE PROTECTION ENGINEER
 BMA MECHANICAL +
 100 Cross Street, Suite 204
 San Luis Obispo, CA 93401
 TEL (805) 544-42-69

ARCHITECT STAMP

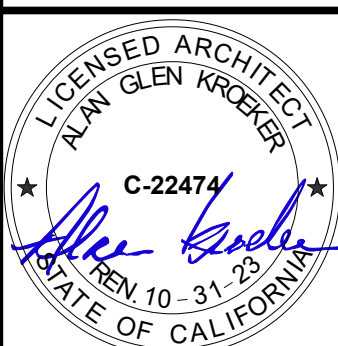

CONSULTANT STAMP

REVISIONS

NO.	DATE	DESCRIPTION
1	04-19-2022	Addendum 1
A	05-19-2022	ADDENDUM A
2	05-23-2022	Addendum 5

THE ARCHITECT DOES NOT REPRESENT THAT THESE PLANS OR THE SPECIFICATIONS ARE SUITABLE FOR ANY SITE OTHER THAN THE ONE FOR WHICH THEY WERE SPECIFICALLY PREPARED. THE ARCHITECT DISCLAIMS RESPONSIBILITY FOR THESE PLANS AND SPECIFICATIONS IF THEY ARE USED IN WHOLE OR IN PART AT ANY OTHER SITE.

PROJECT OWNER & TITLE

ORCUTT UNION SCHOOL DISTRICT
 500 Dyer Street
 Orcutt, CA 93455

ORCUTT ACADEMY HS MUR BUILDING
 610 Pinal Avenue
 Orcutt, CA 93455

SHEET TITLE

FLOOR PLAN

DRAWN BY: FC, HC JOB NUMBER: 20179.01

SHEET NO.

A-201

DATE: MAY 10, 2022

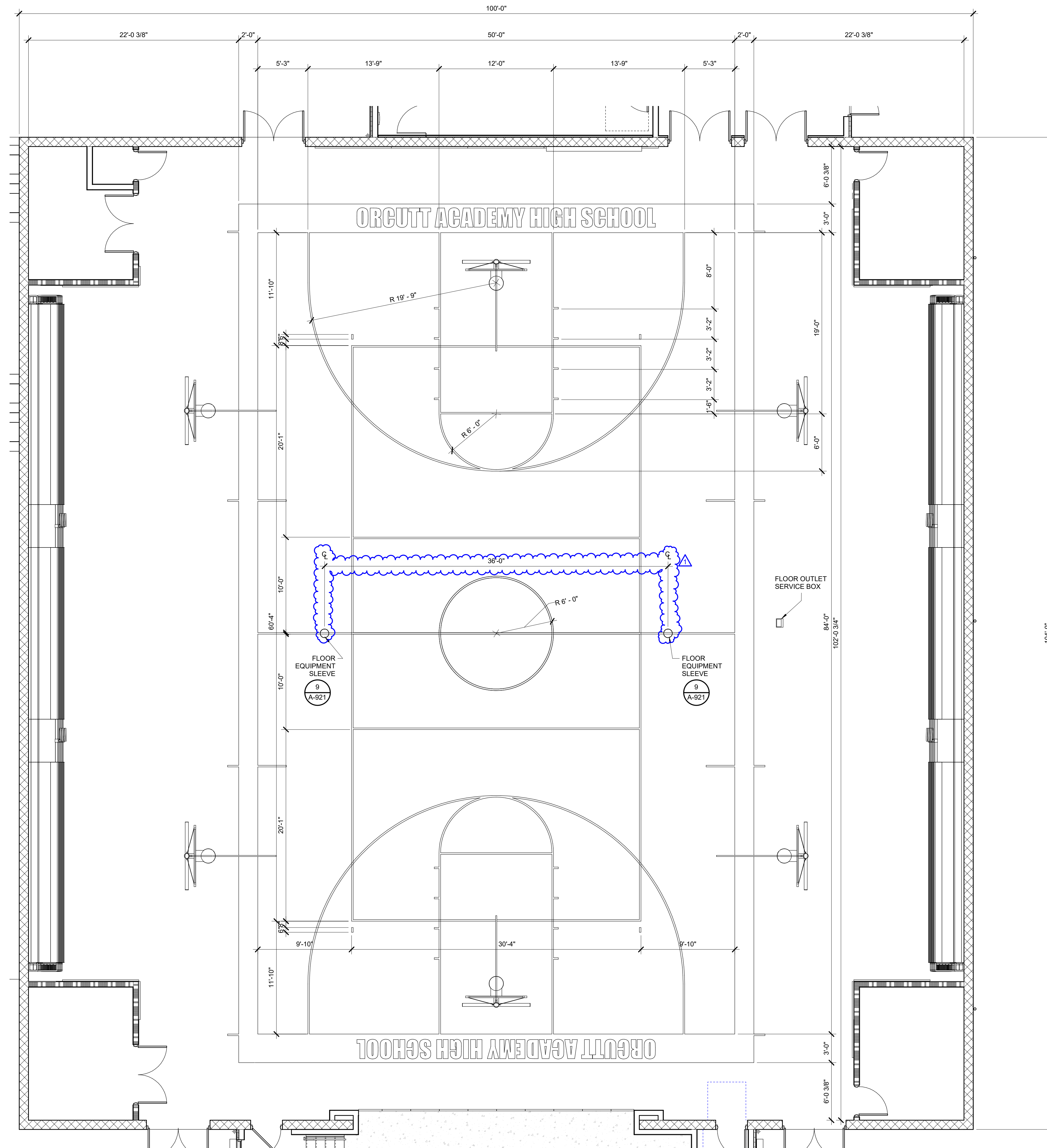

196
ARCHITECTS

560 HIGUERA STREET, SUITE C
SAN LUIS OBISPO, CA 93401
TEL (805) 476-0399

- CONSULTANTS
- CIVIL ENGINEER
STANTEC CONSULTING SERVICES INC.
111 East Victoria Street
Santa Barbara, CA 93101
TEL (805) 680-6830
 - LANDSCAPE ARCHITECT
OASIS ASSOCIATES
2427 Miguelito Court
San Luis Obispo, CA 93401
TEL (805) 541-4509
 - STRUCTURAL ENGINEER
STORK, WOLFE & ASSOCIATES
555 Chorro Street, Suite A1
San Luis Obispo, CA 93405
TEL (805) 548-8500
 - MECHANICAL ENGINEER
BMA MECHANICAL +
100 Cross Street, Suite 204
San Luis Obispo, CA 93401
TEL (805) 544-4269
 - ELECTRICAL ENGINEER
THOMA ENGINEERING
3562 Empleo, Suite C
San Luis Obispo, CA 93406
TEL (805) 543-3850
 - FIRE PROTECTION ENGINEER
BMA MECHANICAL +
100 Cross Street, Suite 204
San Luis Obispo, CA 93401
TEL (805) 544-42-69

ARCHITECT STAMP CONSULTANT STAMP

LICENSED ARCHITECT
A-111 GLEN PARKER
C-22474
ALEX KROGER
STATE OF CALIFORNIA

REVISIONS

NO.	DATE	DESCRIPTION
1	05-23-2022	Addendum 5

THE ARCHITECT DOES NOT REPRESENT THAT THESE PLANS OR THE SPECIFICATIONS ARE SUITABLE FOR ANY SITE OTHER THAN THE ONE FOR WHICH THEY WERE SPECIFICALLY PREPARED. THE ARCHITECT DISCLAIMS RESPONSIBILITY FOR THESE PLANS AND SPECIFICATIONS IF THEY ARE USED IN WHOLE OR IN PART AT ANY OTHER SITE.

PROJECT OWNER & TITLE
ORCUTT UNION SCHOOL DISTRICT
500 Dyer Street
Orcutt, CA 93455

ORCUTT ACADEMY HS MUR BUILDING
610 Pinal Avenue
Orcutt, CA 93455

SHEET TITLE
COURT STRIPING

DRAWN BY: FC JOB NUMBER: 20179.01

SHEET NO.
A-202
DATE: APRIL 5, 2022

FILE LOCATION: C:\Users\HCrutz\Documents\20179_01_OUSD_OAHS MUR_A20_V2_hcnz\PB9K.rvt
DATE PLOTTED: 3/24/2022 2:02:12 PM

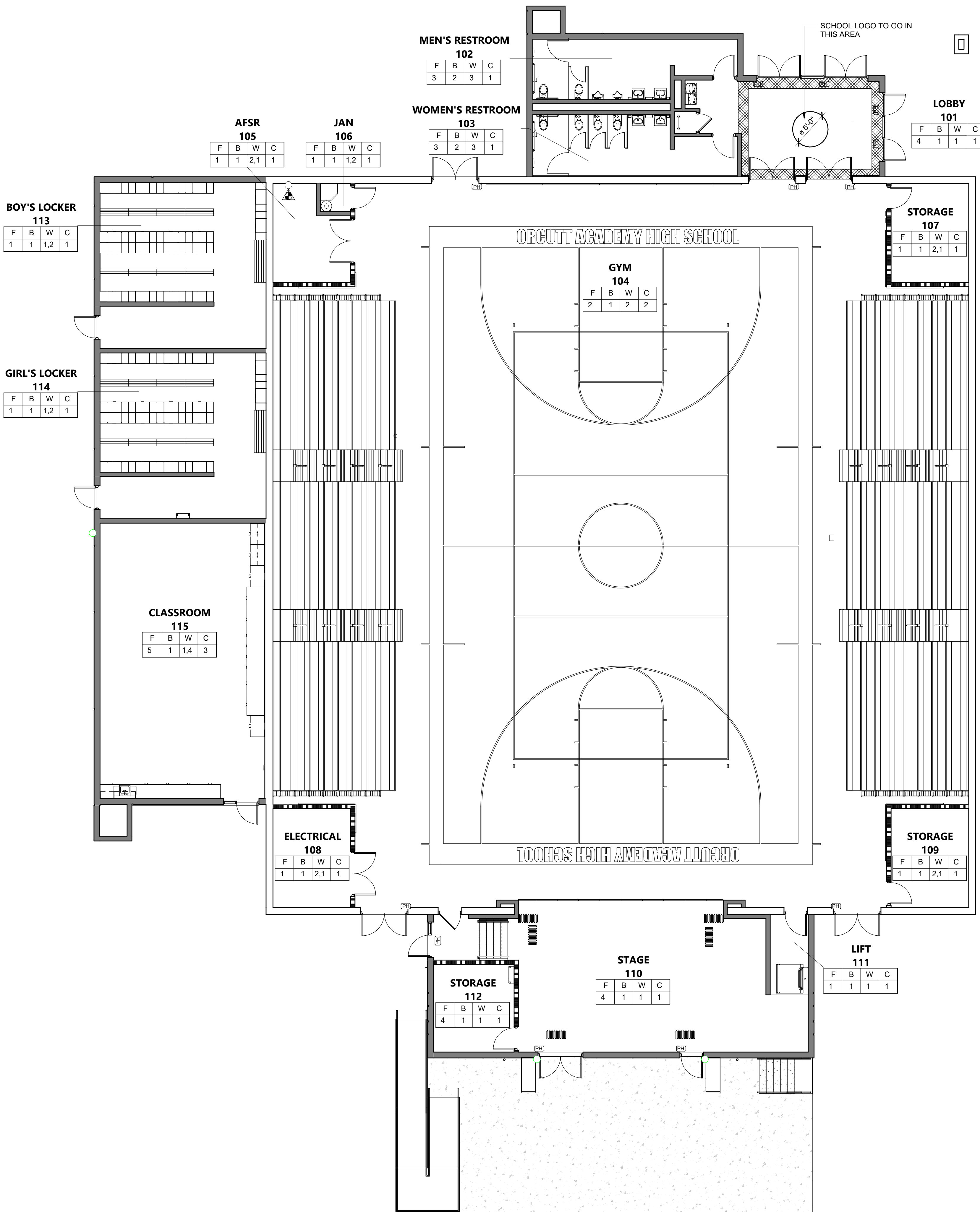

FINISH PLAN 1/8" = 1'-0" 1

FLOOR FINISHES (F)						
(F)	DESCRIPTION	MANUFACTURER	PRODUCT STYLE	COLOR	SPECIFICATION SECTION	REMARKS
1	SEALED CONCRETE					
2	FLOATING SPORTS WOOD FLOOR	CONNOR SPORTS FLOORING	FLOATING WOOD FLOOR	MAPLE #2	096420	ALLIANCE FLOORING SYSTEM
3	CERAMIC TILE		CERAMIC TILE			URBAN PUTTY
4	VINYL FLOORING		VINYL			LOBBY VINYL - HATCHED AREA TO BE ARMSTRONG VINYL COLOR GENTIAN BLUE (51946)-STANDARD EXCELRON IMPERIAL TEXTURE. LIGHTER AREA TO BE ARMSTRONG VINYL COLOR SOFT WARM GRAY (51881)-STANDARD EXCELRON IMPERIAL TEXTURE. STAGE VINYL WILL BE MARMOLEUM COLOR WALTON 123 BLACK
5	CARPET					

BASE FINISHES (B)						
(B)	DESCRIPTION	MANUFACTURER	PRODUCT STYLE	COLOR	SPECIFICATION SECTION	REMARKS
1	6" RUBBER COVERED BASE					
2	CERAMIC TILE					URBAN PUTTY
3						
4						

WALL FINISHES (W)						
(W)	DESCRIPTION	MANUFACTURER	PRODUCT STYLE	COLOR	SPECIFICATION SECTION	REMARKS
1	GYP BOARD, SMOOTH FINISH, PAINTED					
2	CMU, PRECISION, PAINTED (INTERIOR); SPLIT-FACED (EXTERIOR)	AIRVOL BLOCK	PRECISION FACED FOR INTERIOR, SPLIT FACED FOR EXTERIOR	MW 048407A		
3	CERAMIC TILE					COLOR WHEEL CLASSIC 6 X 6 SEMI-GLOSS
4	TACKBOARD					

CEILING FINISHES (C)						
(C)	DESCRIPTION	MANUFACTURER	PRODUCT STYLE	COLOR	SPECIFICATION SECTION	REMARKS
1	PAINTED GYP BOARD (GYP)					
2	ACOUSTICAL STEEL DECK (ASD)					
3	ACOUSTICAL CEILING TILE (ACT)					

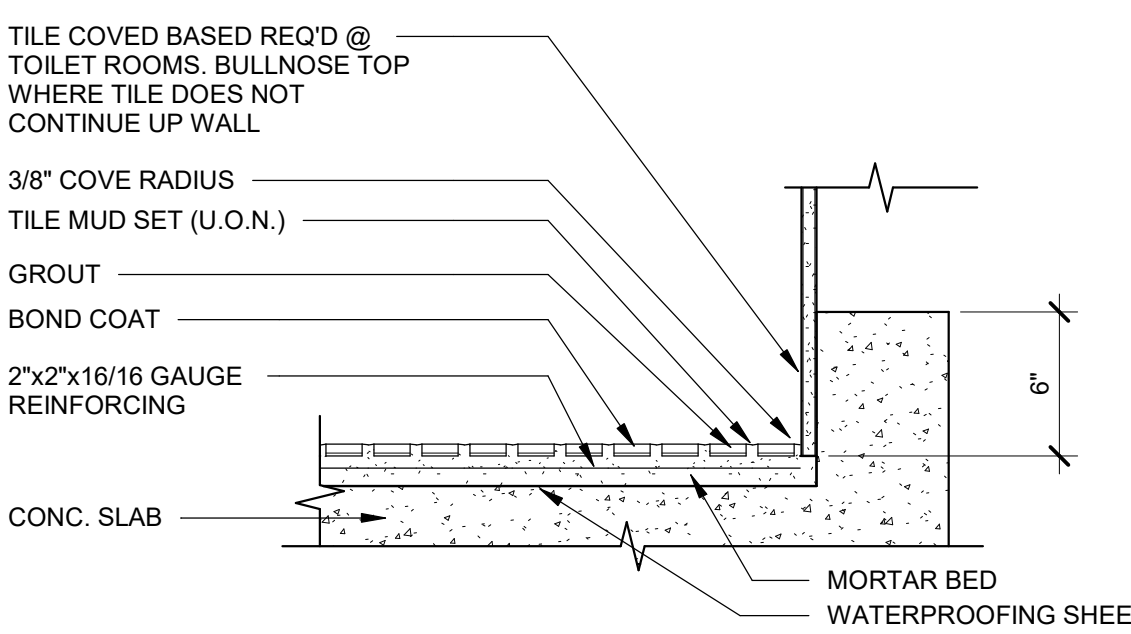
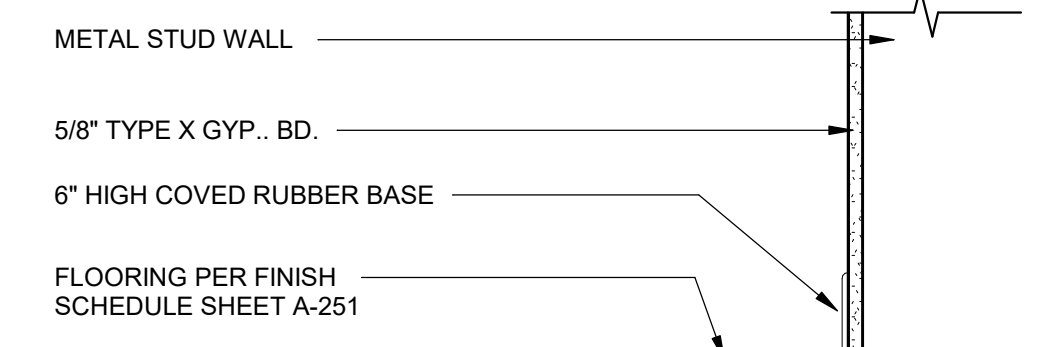

FLOOR BASES 1/2" = 1'-0" 2

- FINISH PLAN GENERAL NOTES**
- CONTRACTOR RESPONSIBLE FOR FIELD VERIFYING MATERIAL DIMENSIONS AT EACH PARTITION IN THE FIELD AS RELATED TO THE OVERALL FINAL PARTITION DIMENSION, PRIOR TO DOOR AND WINDOW SUBMITTALS.
 - FOR MATERIAL FINISHES AND LOCATION OF FINISHES, REFER TO FINISH PLAN, INTERIOR ELEVATIONS AND FINISH SCHEDULE.
 - SPECIFICATIONS SHALL SUPERCEDE DIMENSIONS IN THIS DETAIL AS NECESSARY; CONTRACTOR TO VERIFY.

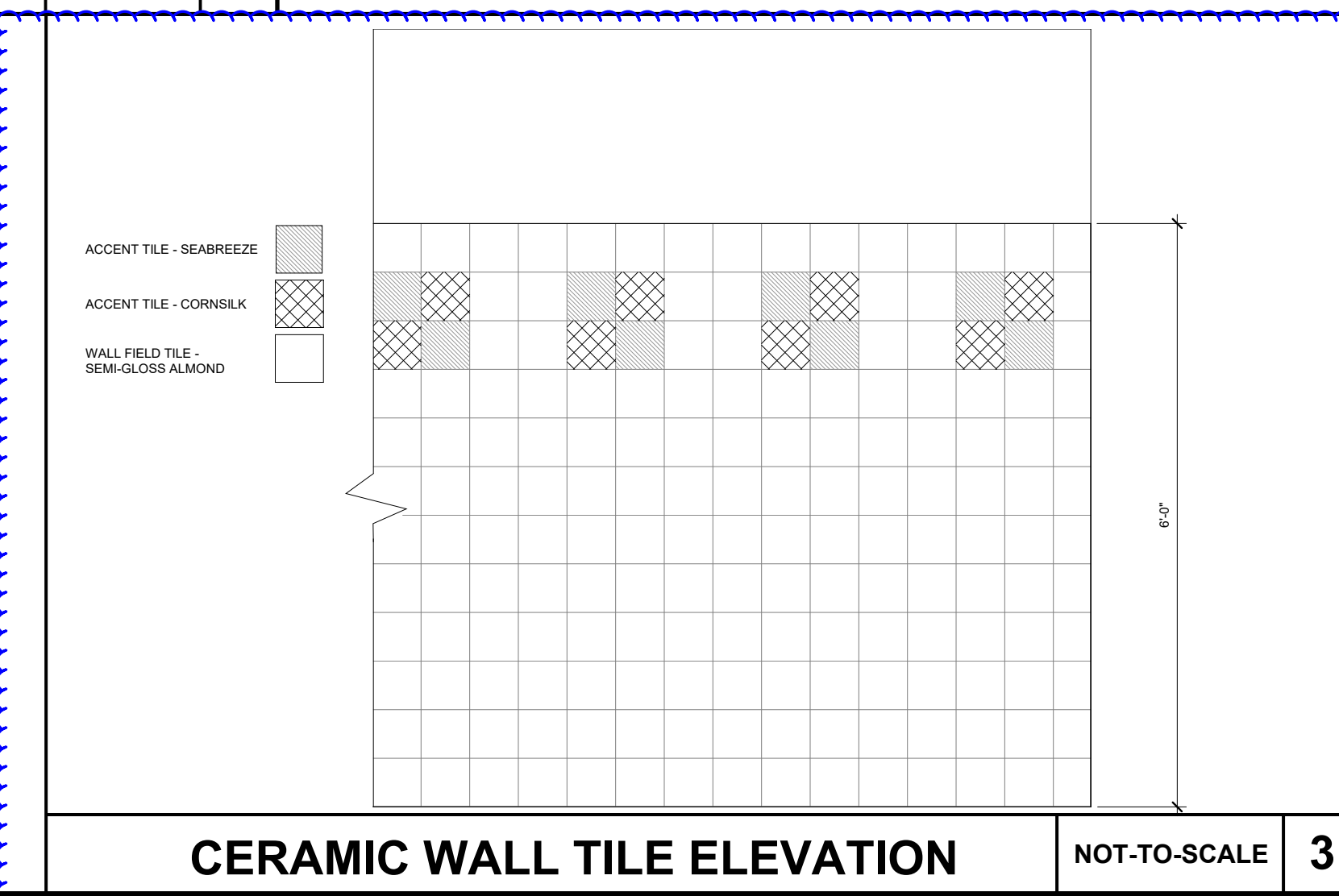

AGENCY APPROVAL DSAE 03-121912

196 ARCHITECTS

560 HIGUERA STREET, SUITE C
SAN LUIS OBISPO, CA 93401
TEL (805) 476-0399

- CONSULTANTS**
- CIVIL ENGINEER**
STANTEC CONSULTING SERVICES INC.
111 East Victoria Street
Santa Barbara, CA 93101
TEL (805) 680-6830
 - LANDSCAPE ARCHITECT**
OASIS ASSOCIATES
2427 Miguelito Court
San Luis Obispo, CA 93401
TEL (805) 541-4509
 - STRUCTURAL ENGINEER**
STORK, WOLFE & ASSOCIATES
555 Chorro Street, Suite A1
San Luis Obispo, CA 93405
TEL (805) 548-8500
 - MECHANICAL ENGINEER**
BMA MECHANICAL +
100 Cross Street, Suite 204
San Luis Obispo, CA 93401
TEL (805) 544-4269
 - ELECTRICAL ENGINEER**
THOMA ENGINEERING
3562 Empeo, Suite C
San Luis Obispo, CA 93406
TEL (805) 543-3850
 - FIRE PROTECTION ENGINEER**
BMA MECHANICAL +
100 Cross Street, Suite 204
San Luis Obispo, CA 93401
TEL (805) 544-42-69

ARCHITECT STAMP
CONSULTANT STAMP

ARCHITECT
AIA REG. NO. C-22474
Alicia Knudsen
MAY 10 - 31 '25
STATE OF CALIFORNIA

REVISIONS

NO.	DATE	DESCRIPTION
1	05-23-2022	Addendum 5

THE ARCHITECT DOES NOT REPRESENT THAT THESE PLANS OR THE SPECIFICATIONS ARE SUITABLE FOR ANY SITE OTHER THAN THE ONE FOR WHICH THEY WERE SPECIFICALLY PREPARED. THE ARCHITECT DISCLAIMS RESPONSIBILITY FOR THESE PLANS AND SPECIFICATIONS IF THEY ARE USED IN WHOLE OR IN PART AT ANY OTHER SITE.

PROJECT OWNER & TITLE
ORCUTT UNION SCHOOL DISTRICT
500 Dyer Street
Orcutt, CA 93455

ORCUTT ACADEMY HS MUR BUILDING
610 Pinal Avenue
Orcutt, CA 93455

SHEET TITLE
FINISH PLAN

DRAWN BY: Author JOB NUMBER: 20179.01
SHEET NO.

A-251
DATE: MARCH 23, 2022



Pre-Bid RFIs: 18

Project: Orcutt Academy HS Multi-Use Building

Project No: 2-2022-02-22-01

Addendum 008

18. Pre-Bid RFI #15: Roofing Clarifications

18.1. Plan Sheet A-702 Detail #5, #10, #15, #3, #8 and #1 call out 6" of XPS insulation. The details show the XPS insulation directly over the metal deck. Is it the architect's intent to omit the thermal barrier of ½" or 5/8" gypsum in the roof assembly? The roofing specifications only call for a Class A fire rating which is an exterior fire rating. The thermal barrier is used for internal fire ratings.

18.1.1. Response: The insulation has been revised to ISO insulation which complies with Class "A" rated roofs. See Addendum 4.

18.2. Plan sheet A 702 Detail #1 calls out ½" backer board. This conflicts with the roofing specifications 075416-10 part 5 #15. Which states "FTR-Cover Board – Secure Rock Gypsum Fiber, ¼" mechanically attached. Please clarify if you want half inch coverboard supplied per the drawings or .25" cover board supplied per the specifications

18.2.1. Response: 0.25" cover board will be used. See 19-Six Addendum 4.

18.3. Specification section 075416-6-part 4 Membrane A calls for basis of design 60 mil Fibertite SM - FB. Is it the owner's intent to specify a product that doesn't meet the building code? The specified product doesn't meet the formulation requirements of ASTM D6754. California building code section 1507.13.2 states "Thermoplastic Single Ply Roof Coverings shall comply with ASTM D4434, ASTM D6754, ASTM D 6878 or CGSB Can/CGSB 37-54. The specified product does not meet the formulation requirements of ASTM D6754 which requires "the sheet shall be formulated from the appropriate polymers and other compounding ingredients. The KEE Polymer shall be a minimum of 50% by weight of the polymer of the sheet." The data sheet for the manufacturer states "60 mil FiberTite-SM-FB surpasses all the physical property requirements enumerated in ASTM D6754-15 standard specification for Ketone Ethylene Ester (KEE) Based Sheet Roofing and is manufactured by request." It omits that it meets the formulation requirements of the standard. To meet the standard, you have to meet all the requirements you can't pick and choose to only meet parts of the standard. The manufacturer's data sheet further on states " 60 mil FiberTite SM-FB is coated on the face with Seaman Corporation's original "KEE" formulation to provide superior hot air welding characteristics, extreme UV resistance, broad chemical resistance and long-term flexibility and reparability for the installed roofing membrane system. The back side of the membrane is coated with a slightly modified (SM) economical version of the seaman Corporation's original KEE compound to control membrane costs while offering additional thickness and weather ability" In essence they are stating that to make the product cheaper they have reduced the KEE content of the back side of the membrane. By reducing the KEE content of the backside they no longer meet the formulation requirements of ASTM D6754 and as such if they don't meet the standard they don't meet the building code. Please see additional pages for documentation.



18.3.1. Response: Basis of Design has been changed to 50 Mil FiberTite-XT-FB per ICC_ESR 1456.

18.4. Under Section 002113-5 #3 Substitution for Specified Items a(1) it states "District must receive any requests for substitution a minimum of 7 calendar days prior to the date of bid opening". This is in direct conflict of the roofing specifications. Roofing Specification section 075416-6 Part 4 A 2. states: "Substitutions will be considered after job is awarded" Please clarify which section of your specifications is correct as they directly conflict one another.

18.4.1. Response: Substitutions will be considered during bidding. Substitutions will need to be an equal or better product. Comparison between substitution and basis-of-design need to be submitted per specification section 01 60 00 Product Requirements

19. Tile size, style, color

19.1. Tile size, style, color

19.1.1. Response: Tile will be Daltile Color Wheel Classic. See 19-Six Addendum 5, revised sheet

A-251.