



Lowell Joint School District

A Tradition of Excellence Since 1906

“Home of Scholars and Champions”

BOARD MEETING

AUGUST 8, 2022

All Board of Trustees board meeting documents are available electronically. Please see:

- Ljsd.org
- Main Tab Labeled: Board
- Sub Tab Labeled: Board Books, Agendas & Meetings
- Current School Year (by year date order)
- Current Board Date (by date order)

Lowell Joint School District
11019 Valley Home Avenue, Whittier, CA 90603

REGULAR MEETING OF THE BOARD OF TRUSTEES
August 8, 2022 – 7:30 p.m.

AGENDA

- I. Call to Order 6:30 p.m.
 - A. Comments from the Public INFORMATION
 - 1. Board Agenda Items: Any member of the audience may speak to any agenda item by submitting a “Presentation Card” (supply located on the table near double exit doors). Please hand the completed card to the secretary. When the item is considered by the Board, individuals submitting presentation cards will be called upon prior to Board action. Speakers must limit their comments to three (3) minutes. The Board shall limit the total time for public input on each item to 30 minutes. With Board consent, the president may increase or decrease the time allowed for public presentation, depending on the topic and the number of persons wishing to be heard.
 - 2. Topics Not on Agenda: Anyone in attendance may address any issue by following the same identification process as shown in I-A-1 above. Since the Board cannot take action on items which are not on the agenda, such items will be referred to the Superintendent for handling. Individuals interested in speaking to items which are not on the agenda will be called upon under Item IVA.
 - B. Closed Session 6:30 p.m.
 - 1. Pupil Personnel Matters/Advice from Legal Counsel – Existing and Anticipated Litigation (Disclosure of Case Name Would Jeopardize Potential Settlement Negotiations)/Real Property/Liability Claims/Negotiations/ Public Employee Appointments – Discipline – Dismissal – Release (Government Code Section 54957)/ Employer/Employee Relations
 - 2. Public Employee Negotiations – Certificated School Employees Association (LJEA)/ Classified School Employees Association (CSEA); Agency Negotiator: Mr. Coombs
 - C. Regular Session Approximately
7:30 p.m.
- II. Preliminary Procedural – Board President
 - A. Salute to the Flag

- B. Reporting Out Action (if any) Taken in Closed Session
- C. Introductions and Welcome of Guests
- D. Comments from the Public
 - 1. Board Agenda Items: Any member of the audience may speak to any agenda item by submitting a “Presentation Card” (supply located on the table near double exit doors). Please hand the completed card to the secretary. When the item is considered by the Board, individuals submitting presentation cards will be called upon prior to Board action. Speakers must limit their comments to three (3) minutes. The Board shall limit the total time for public input on each item to 30 minutes. With Board consent, the president may increase or decrease the time allowed for public presentation, depending on the topic and the number of persons wishing to be heard. INFORMATION
 - 2. Topics Not on Agenda: Anyone in attendance may address any issue by following the same identification process as shown in II-D-1 above. Since the Board cannot take action on items which are not on the agenda, such items will be referred to the Superintendent for handling. Individuals interested in speaking to items which are not on the agenda will be called upon under Item IVA.
- E. Acknowledgement of Correspondence to the Board INFORMATION
- F. Approval of Agenda ACTION
- G. Approval of Minutes from the June 27, 2022, Regular Board Meetings ACTION
- III. Reports INFORMATION
 - A. Timely Information from Board and Superintendent – Board President
- IV. Topics Not on the Agenda
- V. General – Jim Coombs
 - No Items Except on the Consent Calendar
- VI. Business Services – Andrea Reynolds
 - A. 2022/23 Budget Update INFORMATION
- VII. Human Resources – Jim Coombs

No Items Except on Consent

VIII. Educational Services – Sheri McDonald

No Items Except on Consent

IX. Facilities & Operations – David Bennett

- A. Approval of Professional Services Agreement for Utility Locating and Mapping Services with C Below Subsurface Imaging at Rancho Starbuck Intermediate School ACTION
- B. Ratification of Additional Professional Services Agreement with A-Tech Consulting for Hazardous Materials Monitoring, at Meadow Green Elementary School ACTION/
(RATIFICATION)
- C. Approval of Prime Contract Change Order #002, to Increase the Guaranteed Maximum Price with Erickson Hall Construction Company, Inc. to Replace the Main Switch Board at the Meadow Green Elementary School Project ACTION
- D. Approval of Change Order for Additional Professional Services Agreement with RMA Group for Monitoring, Testing, and Inspecting at Jordan Elementary School ACTION/
(RATIFICATION)
- E. Award District-Wide Solid/Organic Waste and Recycling Services to WARE Disposal, Inc. (RFP# 202122-03) ACTION

X. Consent Calendar

Action by the Board in adoption of the “Consent Calendar” means that all items appearing in this section are adopted by one single motion, unless a Member of the Board or the Superintendent requests that any such item be removed from the “Consent Calendar” and voted upon separately. Generally, “Consent Calendar” items are enacted upon in one action to conserve time and permit focus on other-than-routine matters.

A. General - Jim Coombs

- 1. Approval of Ratified Consultant Agreement with Debra Lees to provide support for the Lowell Sustainable Science Literacy Garden at the Maybrook Campus during 2022-2023 School Year ACTION/
(RATIFICATION)
- 2. Approval of Memorandum of Understanding With Walnut Valley Consortium Induction Program, Effective July 1, 2022 through June 30, 2023 ACTION/
(RATIFICATION)

- | | | |
|----|---|--------|
| 3. | Approval of Memorandum of Understanding Educational Fieldwork Agreement with University of Redlands, Effective July 1, 2022 through June 30, 2024 | ACTION |
| 4. | Approval of Consultant Agreement with Mrs. Linda Takacs to Serve as the Director, Lowell Joint Induction Program for the 2022-2023 School Year | ACTION |

B. Business Services – Andrea Reynolds

- | | | |
|----|---|---------------------------|
| 1. | Purchase Order Listing Report/Check Register 2022/2023 #1 | ACTION/
(RATIFICATION) |
| 2. | Consolidated Check Register Listing Report 2022/2023 #1 | ACTION/
(RATIFICATION) |
| 3. | Approval of Contract with Whittier Christian High School, for Student transportation to and from the Meadow Green and Maybrook Campuses during Meadow Green Modernization (Bond Fund) | ACTION |
| 4. | Approval of Agreement with Administrative Services Cooperative, Inc. for Student Transportation Services for the 2022/2023 School Year Not to Exceed \$150,000 | ACTION |
| 5. | Approval of Agreement with Geraldine Chinarian, for Specialized Consulting Services | ACTION |
| 6. | Approval of Agreement with Ho Chong (Christina) Choi, for Specialized Consulting Services | ACTION/
(RATIFICATION) |
| 7. | Budget Adjustments 2021/22 – Estimated Actuals | ACTION |

C. Human Resources – Jim Coombs

- | | | |
|----|---|---------------------------|
| 1. | Employer-Employee Relations/Personnel Report 2022/2023 #1 Which Includes Hiring, Resignations, Contract Adjustments, and Retirements for Certificated, Classified, and Confidential Employees | ACTION/
(RATIFICATION) |
|----|---|---------------------------|

D. Educational Services – Sheri McDonald

- | | | |
|----|---|--------|
| 1. | Approval of Memorandum of Understanding By and Between the Orange County Department of Education and Lowell Joint School District for MHSSA Partnership during the 2021 - 2024 School Years | ACTION |
| 2. | Approval of Agreement #10001508 with the Orange County Department of Education to provide NGSS Professional Learning during the 2022/23 School Year | ACTION |

Meeting of the Board of Trustees

August 8, 2022

Page 5

- | | | |
|----|---|--------|
| 3. | Approval of Memorandum of Understanding Between Boys & Girls Club of La Habra and Lowell Joint School District | ACTION |
| 4. | Approval of Agreement #13249 with Thinking Maps Inc. to Provide Professional Development During the 2022-23 School Year | ACTION |
| 5. | Approval of Agreement #13256 with Thinking Maps Inc. to Provide Professional Development During the 2022-23 School Year | ACTION |

XI.	Board Member/Superintendent Comments	INFORMATION
-----	--------------------------------------	-------------

XII.	Adjournment	ADJOURNMENT
------	-------------	-------------

Recess and/or closed session to be called at the discretion of the Board. Meetings of the Board shall adjourn at or before 11:00 p.m. unless approved by a majority vote of the Board.

Materials related to this agenda submitted to the Board of Trustees less than 72 hours prior to the meeting are available for public inspection by contacting the Superintendent's Office at 11019 Valley Home Avenue, Whittier, CA 90603, or (562) 902-4203 during normal business hours.

The next scheduled Lowell Joint School District Board of Trustees Meeting is Monday, September 12, 2022.

Lowell Joint School District
11019 Valley Home Avenue, Whittier, CA 90603

MINUTES REGULAR MEETING OF THE BOARD OF TRUSTEES
June 27, 2022

Call to Order	President Salinas called the meeting to order at 6:30 p.m. using video conference via zoom meeting ID # 875 8486 4165 for closed session of the Regular Board Meeting of the Board of Trustees, in compliance with Government Code 54953, at Lowell Joint School District, 11019 Valley Home Avenue, Whittier, CA 90603. Anastasia Shackelford and Karen Shaw, Board Members, participated via zoom.
Topics Not on the Agenda	None.
Closed Session	President Salinas declared the meeting recessed to closed session at 6:33 p.m.
Call to Order	President Salinas reconvened the meeting to order at 7:32 p.m. using video conference via zoom meeting ID: 833 4393 1720 for open session Regular Board Meeting of the Board of Trustees, in Compliance with Government code 54953 at Lowell Joint School District, 11019 Valley Home Avenue, Whittier CA 90603. Anastasia Shackelford and Karen Shaw, Board Members, participated via zoom.
	The flag salute was led by Anthony Zegarra, Board of Trustees Member.
	Trustees Present: Melissa A. Salinas and Anthony A. Zegarra. Karen L. Shaw and Anastasia M. Shackelford attended via zoom meeting ID #33 4393 1720.
	Trustees Absent: None
	Staff Present: Jim Coombs, Superintendent of Schools, Andrea Reynolds, Assistant Superintendent of Administrative Services; Sheri McDonald, Assistant Superintendent of Educational Services; and David Bennett, Assistant Superintendent of Facilities and Operations
	Staff Absent: None
Reporting out Action (if any) Taken in Closed Session	None.
Introductions and Welcome of Guests	President Salinas welcomed the guests in attendance, staff members present, Allison Fonti, LJEA president, Leslie Mangold, LJEA lead negotiator and CSEA President, Darleene Pullen.
Acknowledgement of Correspondence	None.

Approval of Agenda	It was moved, seconded, and carried by unanimous roll call vote, (4 – 0) to approve the amended June 27, 2022, Board agenda.
Approval of Minutes	It was moved, seconded, and carried by unanimous roll call vote, (4-0) to approve the minutes from the June 13, 2022, Regular Board Meeting.
Timely Information from Board and Superintendent – Board President	None.
Topics Not on the Agenda	None.
Submission of Williams Litigation Settlement – Quarterly Uniform Complaint Report for Quarter April 1 – June 30, 2022	It was moved, seconded, and carried by unanimous roll call vote, (4-0) to approve the submission of the Williams Litigation Settlement – Quarterly Uniform Complaint Report for Quarter April 1 – June 30, 2022, with zero complaints, and that the Superintendent or designee be authorized to execute the necessary documents.
Adoption of the Proposed 2022/23 Budget	<p>Andrea Reynolds presented the proposed adopted 2022/23 budget. Education Code 42103 requires that the Board of Trustees conduct a Public Hearing of the Proposed 2022/23 Budget. A Public Hearing was held on June 13, 2022, at the Board of Trustees’ regular board meeting and a copy has been available for review at the District Office.</p> <p>Board approval of the 2022/23 Proposed Budget is required prior to July 1 of each year. The budget projects the District will meet its legally required three percent reserve level for the 2022/23 year.</p> <p>It was moved, seconded, and carried by unanimous roll call vote, (4-0) to approve the Adoption of the Proposed 2022/23 Budget, and that the Superintendent or designee be authorized to execute the necessary documents.</p>
Approval of with Agreement, Hauffe Company Inc., (HCI) for Program Management Services, District Wide	It was moved, seconded, and carried by unanimous roll call vote, (4-0) to approve the Agreement with Hauffe Company Inc., (HCI), for Program Management Services, Districtwide, effective July 1, 2022, through June 30, 2023, not to exceed \$125,000, and that the Superintendent or designee be authorized to execute the necessary documents.
Approval of Lease Agreement with Options Surround Care Effective July 1, 2022, through June 30, 2025, at Various Sites in Lowell Joint School District	Options Surround Care (Options) offers full cost and subsidized childcare services to school district community members. It has provided services to the District since 2008. The program is open from 6:30 a.m. until the start of the school day and from the end of the school day until 6:00 p.m. The program serves children ranging in age from 4 years 9 months – 12 attending elementary school. Staff qualified in child development provide age appropriate and challenging activities, in addition to providing homework assistance, which supports a child’s school success. Staff provide a safe, nurturing environment in an effort to enrich the lives of the children

enrolled in the program.

Options currently operates at Jordan, Macy, Meadow Green, and Olita Elementary Schools. Rental income of \$206 per month during months of operation will be received, with an annual increase by the Consumer Price Index (CPI), and utilities will be reimbursed. Additional language is included for Options to provide childcare for the above sites when they attend the District's temporary campus, Maybrook Elementary School. Language also provides for the expansion of childcare services if the district chooses to implement younger ages from zero up to age 3. A termination notice of sixty days is also included in this contract, should the district determine these services are no longer necessary.

It was moved, seconded, and carried by unanimous roll call vote, (4-0) to approve the the lease agreement with Options Surround Care, effective July 1, 2022 through June 30, 2025, at various sites in Lowell Joint School District, and that the Superintendent or designee be authorized to execute the necessary documents.

Approval of District Local Control Accountability Plan (LCAP)

Education Code Section 52062(b)(1) requires that the Board of Trustees conduct a Public Hearing on the District Local Control Accountability Plan. A public hearing was held on June 13, 2022, at the Board of Trustees' regularly scheduled board meeting and a copy has been available for review at the District Office. Additionally, the LCAP was posted on the District's website with an invitation for public feedback. As a result of the public hearing and website posting, District staff has received no additional comments. The Orange County Office of Education (OCDE) will provide feedback over the next few weeks on any necessary clarifications before final approval by the county.

Mrs. Salinas asked, "The parents are asking for the extra mental health support?" Dr. McDonald answered, "Yes, it was a combination that they truly value and appreciate the counselor and psych support. Looking that they have access to the third party vendor 'Care Solace' has been a tremendous support to families that are looking for help in navigating the medical system and getting connected to services. They have been very appreciative of that and that has been a lot of the feedback.

It was moved, seconded, and carried by unanimous roll call vote, (4-0) to adopt the District Local Control Accountability Plan, and that the Superintendent or designee be authorized to execute the necessary documents.

Approval of Local Indicators Rating for submission to the California Dashboard

As part of the LCAP requirements, LEA's must analyze data from multiple sources to determine progress towards goals. There are five State Indicators and four Local Indicators to measure progress for student groups across the eight state priorities.

LEA's measure their progress using locally available information identified in the LCAP such as Benchmarks, SBAC data, Surveys, and FIT reports. The results are shared with the local governing board at a regularly scheduled public meeting. The

district has “met” the criteria on these local indicators by complying with the guidelines and is ready to upload the Local Indicator data as “Met” to the California Dashboard when required.

It was moved, seconded, and carried by unanimous roll call vote, (4-0) to approve the Local Indicator data be uploaded as “Met” to the California Dashboard, and that the Superintendent or designee be authorized to execute the necessary documents.

Universal Prekindergarten Grant Plan

The Universal Prekindergarten Grant is a state early learning planning and capacity building initiative with the goal of expanding access for preschool-age students to prekindergarten programs at local educational agencies. LEAs must self-certify they developed a plan that was presented for consideration by the governing board or body at a public meeting on or before June 30, 2022. This plan must include how all children in the attendance area of the LEA will have access to full-day learning programs the year before kindergarten that meet the needs of parents, including through partnerships with the LEA’s expanded learning offerings, ASES, CSPP, Head Start programs, and other community-based early learning and care programs.

Ms. Shaw asked, “Are any of these pre-K being charged money to the parents?” Dr. McDonald answered, “The families that qualify for the state funded preschool, there is no charge. If they qualify under state funding, the income level is a little higher. For a family of four or make eighty thousand dollars you actually do qualify. In addition to that, we have a for fee based on the a.m. and p.m. (half day) attendance. The cost is about five hundred and fifty dollars a month for the tuition for the full day is eight hundred a month. Some of the funding we have is helping to offset for those that want to do the full day program to help support and bring down that cost of tuition. A sliding scale that we can look at when it comes to these childcare options is similar to what the Boys and Girls Club and Options already do. There is also additional monies for a student that has special needs; they can automatically qualify for something like the state funded preschool slots even if it is not an income issue for that particular family.” Mr. Zegarra asked, “Have you seen a lot of interest?” Dr. McDonald answered, “Yes, our full day preschool is almost full. The a.m. slots are almost full. So we are looking at filling in the afternoon in particular. We are looking at some of our families at Jordan that received speech services. We are looking at offering the speech services in the morning so that they could attend in the afternoon.” Mr. Zegarra asked, “Is it only for students that reside in our attendance boundaries?” Dr. McDonald answered, “Not necessarily for preschool.” Mr. Zegarra asked, “So you have seen folks from outside?” Dr. McDonald answered, “We have some staff in East Whittier that are excited about us having preschool so that they can bring their kids here for preschool.” Mrs. Salinas asked, “How are they getting to know about it?” Dr. McDonald answered, “We have sent things out through the same networks of basic communication that we use within the district. The blasts that go out through the Superintendent’s office, the school sites, website, the director of CSUF and word of mouth.”

It was moved, seconded, and carried by unanimous roll call vote, (4-0) to approve the Universal Prekindergarten Grant Plan, and that the Superintendent or designee be authorized to execute the necessary documents.

Expanded Learning
Opportunities Program Plan

The Expanded Learning Opportunities Program (ELOP) provides funding for afterschool and summer school enrichment programs for transitional kindergarten through sixth grade.

“Expanded learning” includes before school, after school, summer, or intersession learning programs that focus on developing the academic, social, emotional, and physical needs and interests of pupils through hands-on, engaging learning experiences. It is the intent of the Legislature that expanded learning programs are pupil-centered, results driven, include community partners, and complement, but do not replicate, learning activities in the regular school day and school year. The program plan needs to be approved by the Local Educational Agency's (LEA) Governing Board in a public meeting and posted on the LEA's website.

Ms. Shaw asked, “There is budget for materials that are not part of classroom curriculum but specifically for Expanded Learning?” Dr. McDonald answered, “That is correct. Right now, the current budget is sitting around 1.1 million. We have hired four staff positions. Because of the magnitude of the program, we have hired an office manager, a fiscal clerk and two coordinator positions (expanded learning and early learning). Not a hundred percent of the salaries will come out of this. Some will come out of the early childhood learning monies from the preschool. There is money available to contract and provide services to pay staff and provide some of these services for families. This will offset us not having to charge all families. If they are an unduplicated pupil, you can not charge them for anything that you are offering before and after school and for other families if they want to participate and we do not have space available they can still do that they might just need to pay off of a sliding scale.” Mr. Coombs said, “That we are able to grow slow since we do not have to have anything done next year. We are able to grow it and not have this huge pressure.”

It was moved, seconded, and carried by unanimous roll call vote, (4-0) to approve the Expanded Learning Opportunities Program Plan, and that the Superintendent or designee be authorized to execute the necessary documents.

Approval of Piggyback
Contract with Elite Modular
Leasing & Sales, Inc. for the
Purchase, Lease, Relocation,
Dismantling, and Removal
of Division of the State
Architect (DSA) Approved
Portable Buildings

Mrs. Shackelford asked, “How many are we adding?” Mr. Bennett said, “We are adding seven of the single wide regular classrooms and four of the double wide classrooms. We will potentially be leasing a restroom building but they can’t quote us a restroom building this far out. That will be an agenda item down the road.”

It was moved, seconded, and carried by unanimous roll call vote, (4 – 0) to approve the Piggyback Contract with Elite Modular Leasing & Sales, Inc. for the Purchase, Lease, Relocation, Dismantling, and Removal of Division of the State Architect (DSA) Approved Portable Buildings, not to exceed \$350,000, and that the Superintendent of designee be authorized to execute the necessary documents.

Approval of Amendment #1
and Change Order #001, to
Remove the Owner

It was moved, seconded, and carried by unanimous roll call vote, (4 – 0) to approve Amendment #1 and Change Order #001 with Erickson Hall Construction Company for the Meadow Green Elementary School Project, effective June 13, 2022 through

Controlled Insurance Program (OCIP) from the Construction Services Agreement and Insure Directly through Erickson Hall Construction Company, Inc. for the Meadow Green Elementary School Project

August 30, 2023, not to exceed \$94,950 (21.0-00000-0-00000-85000-6210-008000) Measure LL (21.0 Bond Fund), and that the Superintendent or designee be authorized to execute the necessary documents.

Approval of Professional Services Agreement, Koury Engineering & Testing, Inc., for Geotechnical Study at Rancho Starbuck Intermediate School

It was moved, seconded, and carried by a unanimous roll call vote, (4 – 0) to approve the Professional Services Agreement, Koury Engineering & Testing, Inc. for Geotechnical Study, Rancho Starbuck Intermediate School, effective June 28, 2022, through July 31, 2023, not to exceed \$13,540.00, (21.0-00000-0-00000-85000-6282-0011000) Measure LL (21.0 Bond Fund), and that the Superintendent or designee be authorized to execute the necessary documents.

Approval to Utilize San Gabriel Valley Food Services Cooperative Purchasing Group School Districts/Agency Bids for Food and Supplies for the 2022/23 School Year

It was moved, seconded, and carried by a unanimous roll call vote, (4 – 0) to approve the utilization of other agency's bids for Districtwide Nutrition Services products for the 2022/23 school year, and that the Superintendent or designee be authorized to execute the necessary documents.

Consent Calendar

It was moved, seconded, and carried by a unanimous roll call vote, (4 – 0), to approve/ratify the following items, under a consent procedure.

Approval of Independent Contractor Agreement with Andriana Gutierrez, to provide Training for the Special Education Department Staff for the 2022/2023 School Year

Approved the Independent Contractor Agreement with Andriana Gutierrez to provide Training for the Special Education Department Staff, for the 2022/2023 School Year be approved, for an estimated cost not to exceed \$2,000.00, to be paid for with Medi-Cal Funds, and that the Superintendent or designee be authorized to execute the documents.

Approval of the Creative Response to Emotional & Educational Wellness - C.R.E.W. Program

Approved the Creative Response to Emotional & Educational Wellness - C.R.E.W. Program, and that the Superintendent or designee be authorized to execute the documents.

Approval of the El Portal STEAM Innovation Lab: Unlocking Student's Imagination, Creativity and Discovery

Approved the El Portal STEAM Innovation Lab: Unlocking Student's Imagination, Creativity and Discovery, and that the Superintendent or designee be authorized to execute the necessary documents.

Approval of the Rancho-Starbuck Advance Placement Computer Science Program

Approved the Rancho-Starbuck Advance Placement Computer Science Program, and that the Superintendent or designee be authorized to execute the necessary documents.

Approval of Consultant Agreement with Paul Luna to Provide Graphic Design Work for District Communication of Programs and Facilities for the 2022-2023 School Year

Approved the consultant agreement with Paul Luna to provide graphic design work for District communication of programs and facilities for the 2022-2023 school year, for an amount not to exceed \$5,000.00, to be paid from fund 40 account, and that the Superintendent or designee be authorized to execute the necessary documents.

Approval of Consultant Agreement with Debra Lees to provide support for the Lowell Sustainable Science Literacy Garden at the Maybrook Campus during 2022-2023 School Year

Approved the consultant agreement with Mrs. Debra Lees to provide support for the Lowell Joint Sustainable Science Literacy Garden at the Maybrook Campus for the 2022/2023 school year, at the not to exceed amount of \$14,000.00, to be paid from the Title IV Student Support and Academic Enrichment funds, and that the Superintendent or designee be authorized to execute the agreement.

Purchase Order Listing Report/Check Register 2021/2022 #12

Approved the Purchase Order Listing Report/Check Register 2021/2022 #12, issued May 1, 2022, through May 31, 2022, as attached, and that the Superintendent or designee be authorized to execute the necessary documents.

Approval of Agreement with Edgenuity to provide Services for the Virtual Academy during the 2022-2023 School Year

Approved the Agreement with Imagine Learning LLC, not to exceed \$60,000.00 and will be covered by remaining state and federal one-time dollars designated to support distance learning, and the Superintendent or designee be authorized to execute the necessary documents.

Approval of Agreement with Fullerton Joint Union High School District Provision of Library Services for the 2022/23 School Year

In compliance with Ed code Section 18100 which states the governing Board of each school district shall provide school library services for the pupils and teachers of the district by establishing and maintaining school libraries or by contractual arrangements with another public agency. We are contracting with FJUHS D for certificated Library services for the 2022/23 school-year for compliance. The fee not to exceed \$1,000.00 will be paid for by Curriculum department funds.

Approved the Agreement with Fullerton Joint Union High School District for the provision of Library Services for the 2022/23 School Year, not to exceed \$1,000.00 to be be paid by Curriculum department funds, and that the Superintendent or designee be authorized to execute the necessary documents.

Board Member/Superintendent Comments

Mr. Zegarra thanked financial services as they close out the fiscal year and all the work you have done. It has been a pleasure to watch you do that. Congratulations and excellent work.

Mr. Coombs said that it still is not done and they will continue to finish up the year.

He also stated that all of those plans are a credit to Sheri McDonald and Chelle Price. He also followed up with Bill Hinz. We have a retirement gift on his behalf. He promised that he would be here at the board meeting in September.

Mr. Zegarra thanked the faithful audience attendees at the board meetings. It has been an awesome year serving here at this district. As a smaller district, everyone wears a lot more hats and you have done tremendous job this year.

Adjournment

President Salinas adjourned the meeting at 8:31 p.m. in accordance with Government Code Section 54956.9 (a, b, c) and indicated no further public action would be taken.

Date Approved:

Clerk/President/Secretary to the Board of Trustees



Orange County Department of Education
Educational Services Division

**Williams Settlement Legislation
Quarterly Report of Uniform Complaints
2021-22**

District: Lowell Joint School District

District Contact: Mary Jo Evanoff

Title: Executive Assistant to Superintendent/ Certificated Personnel

- | | | | |
|-------------------------------------|------------|-------------------------------|---------------------------------------|
| <input type="checkbox"/> | Quarter #1 | July 1 – September 30, 2021 | Report due by October 29, 2021 |
| <input type="checkbox"/> | Quarter #2 | October 1 – December 31, 2021 | Report due by January 28, 2022 |
| <input type="checkbox"/> | Quarter #3 | January 1 – March 31, 2022 | Report due by April 29, 2022 |
| <input checked="" type="checkbox"/> | Quarter #4 | April 1 – June 30, 2022 | Report due by July 29, 2022 |

Check the box that applies:

- No complaints were filed with any school in the district during the quarter indicated above.
- Complaints were filed with schools in the district during the quarter indicated above. The following chart summarizes the nature and resolution of the complaints.

Type of Complaint	Total # of Complaints	# Resolved	# Unresolved
Textbooks and Instructional Materials	0		
Teacher Vacancies or Missassignments	0		
Facility Conditions	0		
TOTALS	0		

Name of Superintendent: Jim Coombs

Signature of Superintendent:  Date: June 27, 2022

Please submit to:

Orange County Department of Education
P.O. Box 9050, Costa Mesa, CA 92628-9050
Attention: Alicia Gonzalez, Sr. Administrative Assistant/Redhill Site

Phone: (714) 966-4336 Email: aliciagonzalez@ocde.us Fax: (714) 327-1371



**Los Angeles County
Office of Education**
Serving Students • Supporting Communities
Leading Educators

Williams Lawsuit Settlement Quarterly Report on Uniform Complaints 2021-2022

District Name: Lowell Joint School District

Date: June 27, 2022

Person completing this form: MJ Evanoff

Title: Exec Asst to Supt/Cert Personnel

Quarter covered by this report (Check One Below):

- | | | |
|---|--------------------------|------------------|
| <input type="checkbox"/> 1st QTR | July 1 to September 30 | Due 15-Oct 2021 |
| <input type="checkbox"/> 2nd QTR | October 1 to December 31 | Due 14- Jan 2022 |
| <input type="checkbox"/> 3rd QTR | January 1 to March 31 | Due 15-Apr 2022 |
| <input checked="" type="checkbox"/> 4th QTR | April 1 to June 30 | Due 15-Jul 2022 |

Date for information to be reported publicly at governing board meeting: _____

Please check the box that applies:

- No complaints were filed with any school in the district during the quarter indicated above.
- Complaints were filed with schools in the district during the quarter indicated above. The following chart summarizes the nature and resolution of these complaints.

	Number of Complaints Received in Quarter	Number of Complaints Resolved	Number of Complaints Unresolved
Instructional Materials	0		
Facilities	0		
Teacher Vacancy and Misassignment	0		
TOTAL	0		

Print Name of District Superintendent Jim Coombs

Signature of District Superintendent 

Date June 27, 2022

Return the **Quarterly Summary** to:
Williams Legislation Implementation Project
Los Angeles County Office of Education
c/o Kirit Chauhan, Williams Settlement Legislation
9300 Imperial Highway, ASM/Williams ECW 284
Downey, CA 90242

Telephone: (562) 803-8382
FAX: (562) 803-8325
E-Mail: Chauhan_Kirit@lacoed.edu



LOWELL JOINT SCHOOL DISTRICT

2022/2023 Proposed Adopted Budget

Prepared by:

**Andrea Reynolds
Assistant Superintendent of Administrative Services
June 27, 2022**

ANNUAL BUDGET REPORT:

July 1, 2022 Budget Adoption

Insert "X" in applicable boxes:

X This budget was developed using the state-adopted Criteria and Standards. It includes the expenditures necessary to implement the Local Control and Accountability Plan (LCAP) or annual update to the LCAP that will be effective for the budget year. The budget was filed and adopted subsequent to a public hearing by the governing board of the school district pursuant to Education Code sections 33129, 42127, 52060, 52061, and 52062.

X If the budget includes a combined assigned and unassigned ending fund balance above the minimum recommended reserve for economic uncertainties, at its public hearing, the school district complied with the requirements of subparagraphs (B) and (C) of paragraph (2) of subdivision (a) of Education Code Section 42127.

Budget available for
inspection at:

Place: 11019 Valley Home Ave, Whittier CA
Date: June 13, 2022

Public Hearing:

Place: 11019 Valley Home Ave, Whittier CA
Date: June 13, 2022
Time: 7:30 P.M.

Adoption Date: June 27, 2022

Signed: _____
Clerk/Secretary of
the Governing Board
(Original signature
required)

Contact person for additional information on the budget reports:

Name: Andrea Reynolds Telephone: 562-902-4280
Assistant
Title: Superintendent Administrative Services E-mail: areynolds@ljsd.org

Criteria and Standards Review Summary

The following summary is automatically completed based on data provided in the Criteria and Standards Review (Form 01CS). Criteria and standards that are "Not Met," and supplemental information and additional fiscal indicators that are "Yes," may indicate areas of potential concern for fiscal solvency purposes and should be carefully reviewed.

CRITERIA AND STANDARDS		Met	Not Met
1	Average Daily Attendance		
Budgeted (funded) ADA has not been overestimated by more than the standard for the prior fiscal year, or two or more of the previous three fiscal years.			
CRITERIA AND STANDARDS (continued)		Met	Not Met

2	Enrollment	Enrollment has not been overestimated by more than the standard for the prior fiscal year, or two or more of the previous three fiscal years.		
3	ADA to Enrollment	Projected second period (P-2) ADA to enrollment ratio is consistent with historical ratios for the budget and two subsequent fiscal years.		
4	Local Control Funding Formula (LCFF) Revenue	Projected change in LCFF revenue is within the standard for the budget and two subsequent fiscal years.		
5	Salaries and Benefits	Projected ratios of total unrestricted salaries and benefits to total unrestricted general fund expenditures are consistent with historical ratios for the budget and two subsequent fiscal years.		
6a	Other Revenues	Projected operating revenues (e.g., federal, other state, and other local) are within the standard for the budget and two subsequent fiscal years.		
6b	Other Expenditures	Projected operating expenditures (e.g., books and supplies, and services and other operating) are within the standard for the budget and two subsequent fiscal years.		
7	Ongoing and Major Maintenance Account	If applicable, required contribution to the ongoing and major maintenance account (i.e., restricted maintenance account) is included in the budget.		
8	Deficit Spending	Unrestricted deficit spending, if any, has not exceeded the standard for two or more of the last three fiscal years.		
9	Fund Balance	Unrestricted general fund beginning balance has not been overestimated by more than the standard for two or more of the last three fiscal years.		
10	Reserves	Projected available reserves (e.g., reserve for economic uncertainties, unassigned/unappropriated amounts) meet minimum requirements for the budget and two subsequent fiscal years.		
SUPPLEMENTAL INFORMATION			No	Yes
S1	Contingent Liabilities	Are there known or contingent liabilities (e.g., financial or program audits, litigation, state compliance reviews) that may impact the budget?		
S2	Using One-time Revenues to Fund Ongoing Expenditures	Are there ongoing general fund expenditures in excess of one percent of the total general fund expenditures that are funded with one-time resources?		
S3	Using Ongoing Revenues to Fund One-time Expenditures	Are there large non-recurring general fund expenditures that are funded with ongoing general fund revenues?		
S4	Contingent Revenues	Are any projected revenues for the budget or two subsequent fiscal years contingent on reauthorization by the local government, special legislation, or other definitive act (e.g., parcel taxes, forest reserves)?		

S5	Contributions	Have contributions from unrestricted to restricted resources, or transfers to or from the general fund to cover operating deficits, changed by more than the standard for the budget or two subsequent fiscal years?		
SUPPLEMENTAL INFORMATION (continued)			No	Yes
S6	Long-term Commitments	Does the district have long-term (multi year) commitments or debt agreements? • If yes, have annual payments for the budget or two subsequent fiscal years increased over prior year's (2021-22) annual payment?		
S7a	Postemployment Benefits Other than Pensions	Does the district provide postemployment benefits other than pensions (OPEB)? • If yes, are they lifetime benefits? • If yes, do benefits continue beyond age 65? • If yes, are benefits funded by pay-as-you-go?		
S7b	Other Self-insurance Benefits	Does the district provide other self-insurance benefits (e.g., workers' compensation)?		
S8	Status of Labor Agreements	Are salary and benefit negotiations still open for: • Certificated? (Section S8A, Line 1) • Classified? (Section S8B, Line 1) • Management/supervisor/confidential? (Section S8C, Line 1)		
S9	Local Control and Accountability Plan (LCAP)	• Did or will the school district's governing board adopt an LCAP or an update to the LCAP effective for the budget year? • Approval date for adoption of the LCAP or approval of an update to the LCAP:		
S10	LCAP Expenditures	Does the school district's budget include the expenditures necessary to implement the LCAP or annual update to the LCAP as described in the Local Control and Accountability Plan and Annual Update Template?		
ADDITIONAL FISCAL INDICATORS			No	Yes
A1	Negative Cash Flow	Do cash flow projections show that the district will end the budget year with a negative cash balance in the general fund?		
A2	Independent Position Control	Is personnel position control independent from the payroll system?		
A3	Declining Enrollment	Is enrollment decreasing in both the prior fiscal year and budget year?		
A4	New Charter Schools Impacting District Enrollment	Are any new charter schools operating in district boundaries that are impacting the district's enrollment, either in the prior fiscal year or budget year?		

A5	Salary Increases Exceed COLA	Has the district entered into a bargaining agreement where any of the budget or subsequent fiscal years of the agreement would result in salary increases that are expected to exceed the projected state funded cost-of-living adjustment?		
ADDITIONAL FISCAL INDICATORS (continued)			No	Yes
A6	Uncapped Health Benefits	Does the district provide uncapped (100% employer paid) health benefits for current or retired employees?		
A7	Independent Financial System	Is the district's financial system independent from the county office system?		
A8	Fiscal Distress Reports	Does the district have any reports that indicate fiscal distress? If yes, provide copies to the COE, pursuant to EC 42127.6(a).		
A9	Change of CBO or Superintendent	Have there been personnel changes in the superintendent or chief business official (CBO) positions within the last 12 months?		

ANNUAL CERTIFICATION REGARDING SELF-INSURED WORKERS' COMPENSATION CLAIMS

Pursuant to Education Code Section 42141, if a school district, either individually or as a member of a joint powers agency, is self-insured for workers' compensation claims, the superintendent of the school district annually shall provide information to the governing board of the school district regarding the estimated accrued but unfunded cost of those claims. The governing board annually shall certify to the county superintendent of schools the amount of money, if any, that it has decided to reserve in its budget for the cost of those claims.

To the County Superintendent of Schools:

Our district is self-insured for workers' compensation claims as defined in Education Code Section 42141(a):

Total liabilities actuarially determined:	\$	_____
Less: Amount of total liabilities reserved in budget:	\$	_____
Estimated accrued but unfunded liabilities:	\$	0.00

X This school district is self-insured for workers' compensation claims through a JPA, and offers the following information:

Alliance for Schools Cooperative Insurance Program (ASCIP)

This school district is not self-insured for workers' compensation claims.

Signed

Date of Meeting: Jun 27, 2022

Clerk/Secretary of the Governing Board

(Original signature required)

For additional information on this certification, please contact:

Name:	Andrea Reynolds
Title:	Assistant Superintendent Administrative Services
Telephone:	562-902-4280
E-mail:	areynolds@ljsd.org

Description	Resource Codes	Object Codes	2021-22 Estimated Actuals			2022-23 Budget			% Diff Column C & F
			Total Fund col. A + B (C)		Unrestricted (D)	Restricted (E)	Total Fund col. D + E (F)		
			Unrestricted (A)	Restricted (B)					
A. REVENUES									
1) LCFF Sources		8010-8099	28,922,958.00	0.00	28,922,958.00	30,836,281.00	0.00	30,836,281.00	6.6%
2) Federal Revenue		8100-8299	0.00	3,169,820.00	3,169,820.00	0.00	2,373,272.00	2,373,272.00	-25.1%
3) Other State Revenue		8300-8599	588,533.00	3,276,252.00	3,864,785.00	603,692.00	366,978.00	970,670.00	-74.9%
4) Other Local Revenue		8600-8799	144,635.00	2,775,658.00	2,920,293.00	85,000.00	3,119,644.00	3,204,644.00	9.7%
5) TOTAL, REVENUES			29,656,126.00	9,221,730.00	38,877,856.00	31,524,973.00	5,859,894.00	37,384,867.00	-3.8%
B. EXPENDITURES									
1) Certificated Salaries		1000-1999	13,251,255.00	3,426,954.00	16,678,209.00	13,933,867.00	3,493,178.00	17,427,045.00	4.5%
2) Classified Salaries		2000-2999	2,907,124.00	2,563,139.00	5,470,263.00	3,265,698.00	2,750,621.00	6,016,319.00	10.0%
3) Employee Benefits		3000-3999	7,406,608.00	2,361,767.00	9,768,375.00	7,947,153.00	2,694,569.00	10,641,722.00	8.9%
4) Books and Supplies		4000-4999	1,458,898.00	2,453,149.00	3,912,047.00	826,424.00	864,806.00	1,691,230.00	-56.6%
5) Services and Other Operating Expenditures		5000-5999	1,980,220.00	973,916.00	2,954,136.00	2,231,752.00	312,007.00	2,543,759.00	-13.9%
6) Capital Outlay		6000-6999	0.00	78,389.00	78,389.00	6,000.00	5,970.00	11,970.00	-84.7%
7) Other Outgo (excluding Transfers of Indirect Costs)		7100-7299 7400-7499	21,525.00	342,012.00	363,537.00	21,525.00	327,627.00	349,152.00	-4.0%
8) Other Outgo - Transfers of Indirect Costs		7300-7399	(97,414.00)	51,614.00	(45,800.00)	(200,534.00)	49,014.00	(151,520.00)	230.8%
9) TOTAL, EXPENDITURES			26,928,216.00	12,250,940.00	39,179,156.00	28,031,885.00	10,497,792.00	38,529,677.00	-1.7%
C. EXCESS (DEFICIENCY) OF REVENUES OVER EXPENDITURES BEFORE OTHER FINANCING SOURCES AND USES (A5 - B9)									
			2,727,910.00	(3,029,210.00)	(301,300.00)	3,493,088.00	(4,637,898.00)	(1,144,810.00)	280.0%
D. OTHER FINANCING SOURCES/USES									
1) Interfund Transfers									
a) Transfers in									
			0.00	0.00	0.00	0.00	0.00	0.00	0.0%
b) Transfers Out									
			100,000.00	0.00	100,000.00	0.00	0.00	0.00	-100.0%
2) Other Sources/Uses									
a) Sources									
			0.00	0.00	0.00	0.00	0.00	0.00	0.0%
b) Uses									
			0.00	0.00	0.00	0.00	0.00	0.00	0.0%
3) Contributions									
			(3,727,636.00)	3,727,636.00	0.00	(4,094,655.00)	4,094,655.00	0.00	0.0%
4) TOTAL, OTHER FINANCING SOURCES/USES									
			(3,827,636.00)	3,727,636.00	(100,000.00)	(4,094,655.00)	4,094,655.00	0.00	-100.0%
E. NET INCREASE (DECREASE) IN FUND BALANCE (C + D4)									
			(1,099,726.00)	698,426.00	(401,300.00)	(601,567.00)	(543,243.00)	(1,144,810.00)	185.3%
F. FUND BALANCE, RESERVES									
1) Beginning Fund Balance									

Description	Resource Codes	Object Codes	2021-22 Estimated Actuals			2022-23 Budget			% Diff Column C & F
			Unrestricted (A)	Restricted (B)	Total Fund col. A + B (C)	Unrestricted (D)	Restricted (E)	Total Fund col. D + E (F)	
5) Due from Other Funds		9310	0.00	0.00	0.00				
6) Stores		9320	0.00	0.00	0.00				
7) Prepaid Expenditures		9330	0.00	0.00	0.00				
8) Other Current Assets		9340	0.00	0.00	0.00				
9) TOTAL ASSETS			0.00	0.00	0.00				
H. DEFERRED OUTFLOWS OF RESOURCES									
1) Deferred Outflows of Resources		9490	0.00	0.00	0.00				
2) TOTAL DEFERRED OUTFLOWS			0.00	0.00	0.00				
I. LIABILITIES									
1) Accounts Payable		9500	0.00	0.00	0.00				
2) Due to Grantor Governments		9590	0.00	0.00	0.00				
3) Due to Other Funds		9610	0.00	0.00	0.00				
4) Current Loans		9640	0.00	0.00	0.00				
5) Unearned Revenue		9650	0.00	0.00	0.00				
6) TOTAL LIABILITIES			0.00	0.00	0.00				
J. DEFERRED INFLOWS OF RESOURCES									
1) Deferred Inflows of Resources		9690	0.00	0.00	0.00				
2) TOTAL DEFERRED INFLOWS			0.00	0.00	0.00				
K. FUND EQUITY									
Ending Fund Balance, June 30 (G9 + H2) - (I6 + J2)			0.00	0.00	0.00				
LCFF SOURCES									
Principal Apportionment									
State Aid - Current Year		8011	13,468,382.00	0.00	13,468,382.00	15,664,761.00	0.00	15,664,761.00	16.3%
Education Protection Account State Aid - Current Year		8012	2,787,649.00	0.00	2,787,649.00	2,504,593.00	0.00	2,504,593.00	-10.2%
State Aid - Prior Years		8019	0.00	0.00	0.00	0.00	0.00	0.00	0.0%
Tax Relief Subventions									
Homeowners' Exemptions		8021	31,145.00	0.00	31,145.00	31,145.00	0.00	31,145.00	0.0%
Timber Yield Tax		8022	0.00	0.00	0.00	0.00	0.00	0.00	0.0%
Other Subventions/In-Lieu Taxes		8029	2,432,120.00	0.00	2,432,120.00	2,432,120.00	0.00	2,432,120.00	0.0%
County & District Taxes									
Secured Roll Taxes		8041	6,909,219.00	0.00	6,909,219.00	6,909,219.00	0.00	6,909,219.00	0.0%

Description	Resource Codes	Object Codes	2021-22 Estimated Actuals			2022-23 Budget			% Diff Column C & F
			Unrestricted (A)	Restricted (B)	Total Fund col. A + B (C)	Unrestricted (D)	Restricted (E)	Total Fund col. D + E (F)	
Title I, Part D, Local Delinquent Programs	3025	8290	0.00	0.00	0.00		0.00	0.00	0.0%
Title II, Part A, Supporting Effective Instruction	4035	8290	152,617.00	152,617.00	152,617.00		152,617.00	152,617.00	0.0%
Title III, Part A, Immigrant Student Program	4201	8290		5,252.00	5,252.00		0.00	0.00	-100.0%
Title III, Part A, English Learner Program	4203	8290		52,370.00	52,370.00		52,370.00	52,370.00	0.0%
Public Charter Schools Grant Program (PCSGP)	4610	8290		0.00	0.00		0.00	0.00	0.0%
	3040, 3045, 3060, 3061, 3110, 3150, 3155, 3180, 3182, 4037, 4123, 4124, 4126, 4127, 4128, 5630								
Other NCLB / Every Student Succeeds Act		8290		72,611.00	72,611.00		72,611.00	72,611.00	0.0%
Career and Technical Education	3500-3599	8290		0.00	0.00		0.00	0.00	0.0%
All Other Federal Revenue	All Other	8290	0.00	1,691,436.00	1,691,436.00	0.00	1,081,413.00	1,081,413.00	-36.1%
TOTAL FEDERAL REVENUE			0.00	3,169,820.00	3,169,820.00	0.00	2,373,272.00	2,373,272.00	-25.1%
OTHER STATE REVENUE									
Other State Apportionments									
ROC/P Entitlement									
Prior Years	6360	8319		0.00	0.00		0.00	0.00	0.0%
Special Education Master Plan									
Current Year	6500	8311		0.00	0.00		0.00	0.00	0.0%
Prior Years	6500	8319		0.00	0.00		0.00	0.00	0.0%
All Other State Apportionments - Current Year	All Other	8311	0.00	0.00	0.00	0.00	0.00	0.00	0.0%
All Other State Apportionments - Prior Years	All Other	8319	0.00	0.00	0.00	0.00	0.00	0.00	0.0%
Child Nutrition Programs		8520		0.00	0.00		0.00	0.00	0.0%
Mandated Costs Reimbursements		8550	100,222.00	0.00	100,222.00	102,793.00	0.00	102,793.00	2.6%
Lottery - Unrestricted and Instructional Materials		8560	488,311.00	172,345.00	660,656.00	500,899.00	199,745.00	700,644.00	6.1%
Tax Relief Subventions									
Restricted Levies - Other									
Homeowners' Exemptions		8575	0.00	0.00	0.00	0.00	0.00	0.00	0.0%
Other Subventions/In-Lieu Taxes		8576	0.00	0.00	0.00	0.00	0.00	0.00	0.0%
Pass-Through Revenues from									
Slate Sources		8587	0.00	0.00	0.00	0.00	0.00	0.00	0.0%
After School Education and Safety (ASES)	6010	8590		0.00	0.00		0.00	0.00	0.0%
Charter School Facility Grant	6030	8590		0.00	0.00		0.00	0.00	0.0%
Drug/Alcohol/Tobacco Funds	6650, 6690, 6695	8590		0.00	0.00		0.00	0.00	0.0%

Description	Resource Codes	Object Codes	2021-22 Estimated Actuals			2022-23 Budget			% Diff Column C & F
			Unrestricted (A)	Restricted (B)	Total Fund col. A + B (C)	Unrestricted (D)	Restricted (E)	Total Fund col. D + E (F)	
Transportation Fees From Individuals		8675	0.00	0.00	0.00	0.00	0.00	0.00	0.0%
Interagency Services		8677	0.00	0.00	0.00	0.00	0.00	0.00	0.0%
Mitigation/Developer Fees		8681	0.00	0.00	0.00	0.00	0.00	0.00	0.0%
All Other Fees and Contracts		8689	0.00	0.00	0.00	0.00	0.00	0.00	0.0%
Other Local Revenue									
Plus: Miscellaneous Funds Non-LCFF (50 Percent) Adjustment		8691	0.00	0.00	0.00	0.00	0.00	0.00	0.0%
Pass-Through Revenue from Local Sources		8697	0.00	0.00	0.00	0.00	0.00	0.00	0.0%
All Other Local Revenue		8699	90,332.00	84,400.00	174,732.00	40,000.00	84,400.00	124,400.00	-28.8%
Tuition		8710	0.00	0.00	0.00	0.00	0.00	0.00	0.0%
All Other Transfers In		8781-8783	0.00	0.00	0.00	0.00	0.00	0.00	0.0%
Transfers of Apportionments									
Special Education SELPA Transfers									
From Districts or Charter Schools	6500	8791	0.00	0.00	0.00	0.00	0.00	0.00	0.0%
From County Offices	6500	8792	2,691,258.00	0.00	2,691,258.00	0.00	3,035,244.00	3,035,244.00	12.8%
From JPAs	6500	8793	0.00	0.00	0.00	0.00	0.00	0.00	0.0%
ROC/P Transfers									
From Districts or Charter Schools	6360	8791	0.00	0.00	0.00	0.00	0.00	0.00	0.0%
From County Offices	6360	8792	0.00	0.00	0.00	0.00	0.00	0.00	0.0%
From JPAs	6360	8793	0.00	0.00	0.00	0.00	0.00	0.00	0.0%
Other Transfers of Apportionments									
From Districts or Charter Schools	All Other	8791	0.00	0.00	0.00	0.00	0.00	0.00	0.0%
From County Offices	All Other	8792	0.00	0.00	0.00	0.00	0.00	0.00	0.0%
From JPAs	All Other	8793	0.00	0.00	0.00	0.00	0.00	0.00	0.0%
All Other Transfers In from All Others		8799	0.00	0.00	0.00	0.00	0.00	0.00	0.0%
TOTAL, OTHER LOCAL REVENUE			144,635.00	2,775,658.00	2,920,293.00	85,000.00	3,119,644.00	3,204,644.00	9.7%
TOTAL REVENUES			29,656,126.00	9,221,730.00	38,877,856.00	31,524,973.00	5,859,894.00	37,384,867.00	-3.6%
CERTIFICATED SALARIES									
Certificated Teachers' Salaries		1100	11,653,315.00	2,674,918.00	14,328,233.00	12,045,617.00	2,575,953.00	14,621,570.00	2.0%
Certificated Pupil Support Salaries		1200	377,848.00	317,816.00	695,664.00	391,021.00	272,623.00	663,644.00	-4.6%
Certificated Supervisors' and Administrators' Salaries		1300	1,220,092.00	434,220.00	1,654,312.00	1,497,229.00	644,602.00	2,141,831.00	29.5%
Other Certificated Salaries		1900	0.00	0.00	0.00	0.00	0.00	0.00	0.0%

Description	Resource Codes	Object Codes	2021-22 Estimated Actuals			2022-23 Budget			% Diff Column C & F
			Unrestricted (A)	Restricted (B)	Total Fund col. A + B (C)	Unrestricted (D)	Restricted (E)	Total Fund col. D + E (F)	
Rentals, Leases, Repairs, and Noncapitalized Improvements		5600	205,090.00	0.00	205,090.00	203,315.00	0.00	203,315.00	-0.9%
Transfers of Direct Costs		5710	0.00	0.00	0.00	0.00	0.00	0.00	0.0%
Transfers of Direct Costs - Interfund		5750	(58,000.00)	0.00	(58,000.00)	(65,000.00)	0.00	(65,000.00)	12.1%
Professional/Consulting Services and Operating Expenditures		5800	643,560.00	712,946.00	1,356,506.00	785,230.00	135,373.00	920,603.00	-32.1%
Communications		5900	203,059.00	0.00	203,059.00	190,939.00	0.00	190,939.00	-6.0%
TOTAL, SERVICES AND OTHER OPERATING EXPENDITURES			1,980,220.00	973,916.00	2,954,136.00	2,231,752.00	312,007.00	2,543,759.00	-13.9%
CAPITAL OUTLAY									
Land		6100	0.00	0.00	0.00	0.00	0.00	0.00	0.0%
Land Improvements		6170	0.00	0.00	0.00	0.00	0.00	0.00	0.0%
Buildings and Improvements of Buildings		6200	0.00	0.00	0.00	0.00	0.00	0.00	0.0%
Books and Media for New School Libraries or Major Expansion of School Libraries		6300	0.00	0.00	0.00	0.00	0.00	0.00	0.0%
Equipment		6400	0.00	78,389.00	78,389.00	6,000.00	5,970.00	11,970.00	-84.7%
Equipment Replacement		6500	0.00	0.00	0.00	0.00	0.00	0.00	0.0%
Lease Assets		6600	0.00	0.00	0.00	0.00	0.00	0.00	0.0%
TOTAL, CAPITAL OUTLAY			0.00	78,389.00	78,389.00	6,000.00	5,970.00	11,970.00	-84.7%
OTHER OUTGO (excluding Transfers of Indirect Costs)									
Tuition									
Tuition for Instruction Under Interdistrict									
Attendance Agreements		7110	0.00	0.00	0.00	0.00	0.00	0.00	0.0%
State Special Schools		7130	0.00	0.00	0.00	0.00	0.00	0.00	0.0%
Tuition, Excess Costs, and/or Deficit Payments									
Payments to Districts or Charter Schools		7141	0.00	89,000.00	89,000.00	0.00	54,000.00	54,000.00	-39.3%
Payments to County Offices		7142	21,525.00	253,012.00	274,537.00	21,525.00	273,627.00	295,152.00	7.5%
Payments to JPAs		7143	0.00	0.00	0.00	0.00	0.00	0.00	0.0%
Transfers of Pass-Through Revenues									
To Districts or Charter Schools		7211	0.00	0.00	0.00	0.00	0.00	0.00	0.0%
To County Offices		7212	0.00	0.00	0.00	0.00	0.00	0.00	0.0%
To JPAs		7213	0.00	0.00	0.00	0.00	0.00	0.00	0.0%
Special Education SELPA Transfers of Apportionments									

Description	Resource Codes	Object Codes	2021-22 Estimated Actuals			2022-23 Budget			% Diff Column C & F
			Unrestricted (A)	Restricted (B)	Total Fund col. A + B (C)	Unrestricted (D)	Restricted (E)	Total Fund col. D + E (F)	
Other Authorized Interfund Transfers Out		7619	0.00	0.00	0.00	0.00	0.00	0.00	0.0%
(b) TOTAL, INTERFUND TRANSFERS OUT			100,000.00	0.00	100,000.00	0.00	0.00	0.00	-100.0%
OTHER SOURCES/USES									
SOURCES									
State Apportionments		8931	0.00	0.00	0.00	0.00	0.00	0.00	0.0%
Emergency Apportionments									
Proceeds									
Proceeds from Disposal of Capital Assets		8953	0.00	0.00	0.00	0.00	0.00	0.00	0.0%
Other Sources									
Transfers from Funds of Lapsed/Reorganized LEAs		8965	0.00	0.00	0.00	0.00	0.00	0.00	0.0%
Long-Term Debt Proceeds									
Proceeds from Certificates of Participation		8971	0.00	0.00	0.00	0.00	0.00	0.00	0.0%
Proceeds from Leases		8972	0.00	0.00	0.00	0.00	0.00	0.00	0.0%
Proceeds from Lease Revenue Bonds		8973	0.00	0.00	0.00	0.00	0.00	0.00	0.0%
All Other Financing Sources		8979	0.00	0.00	0.00	0.00	0.00	0.00	0.0%
(c) TOTAL, SOURCES			0.00	0.00	0.00	0.00	0.00	0.00	0.0%
USES									
Transfers of Funds from Lapsed/Reorganized LEAs		7651	0.00	0.00	0.00	0.00	0.00	0.00	0.0%
All Other Financing Uses		7699	0.00	0.00	0.00	0.00	0.00	0.00	0.0%
(d) TOTAL, USES			0.00	0.00	0.00	0.00	0.00	0.00	0.0%
CONTRIBUTIONS									
Contributions from Unrestricted Revenues		8980	(3,727,636.00)	3,727,636.00	0.00	(4,094,655.00)	4,094,655.00	0.00	0.0%
Contributions from Restricted Revenues		8990	0.00	0.00	0.00	0.00	0.00	0.00	0.0%
(e) TOTAL, CONTRIBUTIONS			(3,727,636.00)	3,727,636.00	0.00	(4,094,655.00)	4,094,655.00	0.00	0.0%
TOTAL, OTHER FINANCING SOURCES/USES (a - b + c - d + e)			(3,827,636.00)	3,727,636.00	(100,000.00)	(4,094,655.00)	4,094,655.00	0.00	-100.0%

Description	Function Codes	Object Codes	2021-22 Estimated Actuals			2022-23 Budget			% Diff Column C & F
			Unrestricted (A)	Restricted (B)	Total Fund col. A + B (C)	Unrestricted (D)	Restricted (E)	Total Fund col. D + E (F)	
a) As of July 1 - Unaudited		9791	11,276,829.00	1,056,593.00	12,333,422.00	10,177,103.00	1,755,019.00	11,932,122.00	-3.3%
b) Audit Adjustments		9793	0.00	0.00	0.00	0.00	0.00	0.00	0.0%
c) As of July 1 - Audited (F1a + F1b)			11,276,829.00	1,056,593.00	12,333,422.00	10,177,103.00	1,755,019.00	11,932,122.00	-3.3%
d) Other Restatements		9795	0.00	0.00	0.00	0.00	0.00	0.00	0.0%
e) Adjusted Beginning Balance (F1c + F1d)			11,276,829.00	1,056,593.00	12,333,422.00	10,177,103.00	1,755,019.00	11,932,122.00	-3.3%
2) Ending Balance, June 30 (E + F1e)			10,177,103.00	1,755,019.00	11,932,122.00	9,575,536.00	1,211,776.00	10,787,312.00	-9.6%
Components of Ending Fund Balance									
a) Nonspendable									
Revolving Cash		9711	10,000.00	0.00	10,000.00	30,000.00	0.00	30,000.00	200.0%
Stores		9712	0.00	0.00	0.00	0.00	0.00	0.00	0.0%
Prepaid Items		9713	0.00	0.00	0.00	0.00	0.00	0.00	0.0%
All Others		9719	0.00	0.00	0.00	0.00	0.00	0.00	0.0%
b) Restricted		9740	0.00	1,755,019.00	1,755,019.00	0.00	1,211,776.00	1,211,776.00	-31.0%
c) Committed									
Stabilization Arrangements		9750	0.00	0.00	0.00	0.00	0.00	0.00	0.0%
Other Commitments (by Resource/Object)		9760	0.00	0.00	0.00	6,934,344.00	0.00	6,934,344.00	New
d) Assigned									
Other Assignments (by Resource/Object)		9780	0.00	0.00	0.00	0.00	0.00	0.00	0.0%
e) Unassigned/Unappropriated									
Reserve for Economic Uncertainties		9789	0.00	0.00	0.00	1,926,484.00	0.00	1,926,484.00	New
Unassigned/Unappropriated Amount		9790	10,167,103.00	0.00	10,167,103.00	684,708.00	0.00	684,708.00	-93.3%

Description	Resource Codes	Object Codes	2021-22 Estimated Actuals	2022-23 Budget	Percent Difference
A. REVENUES					
1) LCFF Sources		8010-8099	0.00	0.00	0.0%
2) Federal Revenue		8100-8299	1,791,620.00	1,970,782.00	10.0%
3) Other State Revenue		8300-8599	122,254.00	134,479.00	10.0%
4) Other Local Revenue		8600-8799	73,145.00	74,145.00	1.4%
5) TOTAL, REVENUES			1,987,019.00	2,179,406.00	9.7%
B. EXPENDITURES					
1) Certificated Salaries		1000-1999	0.00	0.00	0.0%
2) Classified Salaries		2000-2999	540,772.00	573,658.00	6.1%
3) Employee Benefits		3000-3999	182,661.00	208,434.00	14.1%
4) Books and Supplies		4000-4999	651,453.00	895,507.00	37.5%
5) Services and Other Operating Expenditures		5000-5999	18,228.00	33,147.00	81.8%
6) Capital Outlay		6000-6999	0.00	100,000.00	New
7) Other Outgo (excluding Transfers of Indirect Costs)		7100-7299,7400-7499	0.00	0.00	0.0%
8) Other Outgo - Transfers of Indirect Costs		7300-7399	45,800.00	45,800.00	0.0%
9) TOTAL, EXPENDITURES			1,438,914.00	1,856,546.00	29.0%
C. EXCESS (DEFICIENCY) OF REVENUES OVER EXPENDITURES BEFORE OTHER FINANCING SOURCES AND USES (A5 - B9)			548,105.00	322,860.00	-41.1%
D. OTHER FINANCING SOURCES/USES					
1) Interfund Transfers					
a) Transfers In		8900-8929	0.00	0.00	0.0%
b) Transfers Out		7600-7629	0.00	0.00	0.0%
2) Other Sources/Uses					
a) Sources		8930-8979	0.00	0.00	0.0%
b) Uses		7630-7699	0.00	0.00	0.0%
3) Contributions		8980-8999	0.00	0.00	0.0%
4) TOTAL, OTHER FINANCING SOURCES/USES			0.00	0.00	0.0%
E. NET INCREASE (DECREASE) IN FUND BALANCE (C + D4)			548,105.00	322,860.00	-41.1%
F. FUND BALANCE, RESERVES					
1) Beginning Fund Balance					
a) As of July 1 - Unaudited		9791	1,033,350.00	1,581,455.00	53.0%
b) Audit Adjustments		9793	0.00	0.00	0.0%
c) As of July 1 - Audited (F1a + F1b)			1,033,350.00	1,581,455.00	53.0%
d) Other Restatements		9795	0.00	0.00	0.0%
e) Adjusted Beginning Balance (F1c + F1d)			1,033,350.00	1,581,455.00	53.0%
2) Ending Balance, June 30 (E + F1e)			1,581,455.00	1,904,315.00	20.4%
Components of Ending Fund Balance					
a) Nonspendable					
Revolving Cash		9711	0.00	0.00	0.0%
Stores		9712	0.00	0.00	0.0%
Prepaid Items		9713	0.00	0.00	0.0%
All Others		9719	0.00	0.00	0.0%
b) Restricted		9740	1,581,455.00	1,904,315.00	20.4%
c) Committed					
Stabilization Arrangements		9750	0.00	0.00	0.0%
Other Commitments		9760	0.00	0.00	0.0%
d) Assigned					
Other Assignments		9780	0.00	0.00	0.0%
e) Unassigned/Unappropriated Reserve for Economic Uncertainties		9789	0.00	0.00	0.0%
Unassigned/Unappropriated Amount		9790	0.00	0.00	0.0%
G. ASSETS					
1) Cash					
a) in County Treasury		9110	0.00		
1) Fair Value Adjustment to Cash in County Treasury		9111	0.00		
b) in Banks		9120	0.00		

Description	Resource Codes	Object Codes	2021-22 Estimated Actuals	2022-23 Budget	Percent Difference
Classified Supervisors' and Administrators' Salaries		2300	81,401.00	88,467.00	8.7%
Clerical, Technical and Office Salaries		2400	42,230.00	48,133.00	14.0%
Other Classified Salaries		2900	0.00	0.00	0.0%
TOTAL, CLASSIFIED SALARIES			540,772.00	573,658.00	6.1%
EMPLOYEE BENEFITS					
STRS		3101-3102	0.00	0.00	0.0%
PERS		3201-3202	87,127.00	95,649.00	9.8%
OASDI/Medicare/Alternative		3301-3302	32,302.00	37,088.00	14.8%
Health and Welfare Benefits		3401-3402	54,310.00	65,451.00	20.5%
Unemployment Insurance		3501-3502	2,098.00	2,409.00	14.8%
Workers' Compensation		3601-3602	6,824.00	7,837.00	14.8%
OPEB, Allocated		3701-3702	0.00	0.00	0.0%
OPEB, Active Employees		3751-3752	0.00	0.00	0.0%
Other Employee Benefits		3901-3902	0.00	0.00	0.0%
TOTAL, EMPLOYEE BENEFITS			182,661.00	208,434.00	14.1%
BOOKS AND SUPPLIES					
Books and Other Reference Materials		4200	0.00	0.00	0.0%
Materials and Supplies		4300	93,419.00	121,446.00	30.0%
Noncapitalized Equipment		4400	1,064.00	50,000.00	4,599.2%
Food		4700	556,970.00	724,061.00	30.0%
TOTAL, BOOKS AND SUPPLIES			651,453.00	895,507.00	37.5%
SERVICES AND OTHER OPERATING EXPENDITURES					
Subagreements for Services		5100	0.00	0.00	0.0%
Travel and Conferences		5200	260.00	300.00	15.4%
Dues and Memberships		5300	250.00	250.00	0.0%
Insurance		5400-5450	0.00	0.00	0.0%
Operations and Housekeeping Services		5500	2,820.00	3,102.00	10.0%
Rentals, Leases, Repairs, and Noncapitalized Improvements		5600	4,007.00	18,000.00	349.2%
Transfers of Direct Costs		5710	0.00	0.00	0.0%
Transfers of Direct Costs - Interfund		5750	0.00	0.00	0.0%
Professional/Consulting Services and Operating Expenditures		5800	10,891.00	11,495.00	5.5%
Communications		5900	0.00	0.00	0.0%
TOTAL, SERVICES AND OTHER OPERATING EXPENDITURES			18,228.00	33,147.00	81.8%
CAPITAL OUTLAY					
Buildings and Improvements of Buildings		6200	0.00	0.00	0.0%
Equipment		6400	0.00	0.00	0.0%
Equipment Replacement		6500	0.00	100,000.00	New
Lease Assets		6600	0.00	0.00	0.0%
TOTAL, CAPITAL OUTLAY			0.00	100,000.00	New
OTHER OUTGO (excluding Transfers of Indirect Costs)					
Debt Service					
Debt Service - Interest		7438	0.00	0.00	0.0%
Other Debt Service - Principal		7439	0.00	0.00	0.0%
TOTAL, OTHER OUTGO (excluding Transfers of Indirect Costs)			0.00	0.00	0.0%
OTHER OUTGO - TRANSFERS OF INDIRECT COSTS					
Transfers of Indirect Costs - Interfund		7350	45,800.00	45,800.00	0.0%
TOTAL, OTHER OUTGO - TRANSFERS OF INDIRECT COSTS			45,800.00	45,800.00	0.0%
TOTAL, EXPENDITURES			1,438,914.00	1,856,546.00	29.0%
INTERFUND TRANSFERS					
INTERFUND TRANSFERS IN					
From: General Fund		8916	0.00	0.00	0.0%
Other Authorized Interfund Transfers In		8919	0.00	0.00	0.0%
(a) TOTAL, INTERFUND TRANSFERS IN			0.00	0.00	0.0%
INTERFUND TRANSFERS OUT					
Other Authorized Interfund Transfers Out		7619	0.00	0.00	0.0%

Description	Function Codes	Object Codes	2021-22 Estimated Actuals	2022-23 Budget	Percent Difference
A. REVENUES					
1) LCFF Sources		8010-8099	0.00	0.00	0.0%
2) Federal Revenue		8100-8299	1,791,620.00	1,970,782.00	10.0%
3) Other State Revenue		8300-8599	122,254.00	134,479.00	10.0%
4) Other Local Revenue		8600-8799	73,145.00	74,145.00	1.4%
5) TOTAL, REVENUES			1,987,019.00	2,179,406.00	9.7%
B. EXPENDITURES (Objects 1000-7999)					
1) Instruction	1000-1999		0.00	0.00	0.0%
2) Instruction - Related Services	2000-2999		0.00	0.00	0.0%
3) Pupil Services	3000-3999		1,259,259.00	1,560,257.00	23.9%
4) Ancillary Services	4000-4999		0.00	0.00	0.0%
5) Community Services	5000-5999		0.00	0.00	0.0%
6) Enterprise	6000-6999		0.00	0.00	0.0%
7) General Administration	7000-7999		45,800.00	45,800.00	0.0%
8) Plant Services	8000-8999		133,950.00	250,613.00	87.1%
9) Other Outgo	9000-9999	Except 7600-7699	0.00	0.00	0.0%
10) TOTAL, EXPENDITURES			1,439,009.00	1,856,670.00	29.0%
C. EXCESS (DEFICIENCY) OF REVENUES OVER EXPENDITURES BEFORE OTHER FINANCING SOURCES AND USES (A5 - B10)			548,010.00	322,736.00	-41.1%
D. OTHER FINANCING SOURCES/USES					
1) Interfund Transfers					
a) Transfers In		8900-8929	0.00	0.00	0.0%
b) Transfers Out		7600-7629	0.00	0.00	0.0%
2) Other Sources/Uses					
a) Sources		8930-8979	0.00	0.00	0.0%
b) Uses		7630-7699	0.00	0.00	0.0%
3) Contributions		8980-8999	0.00	0.00	0.0%
4) TOTAL, OTHER FINANCING SOURCES/USES			0.00	0.00	0.0%
E. NET INCREASE (DECREASE) IN FUND BALANCE (C + D4)			548,010.00	322,736.00	-41.1%
F. FUND BALANCE, RESERVES					
1) Beginning Fund Balance					
a) As of July 1 - Unaudited		9791	1,033,350.00	1,581,455.00	53.0%
b) Audit Adjustments		9793	0.00	0.00	0.0%
c) As of July 1 - Audited (F1a + F1b)			1,033,350.00	1,581,455.00	53.0%
d) Other Restatements		9795	0.00	0.00	0.0%
e) Adjusted Beginning Balance (F1c + F1d)			1,033,350.00	1,581,455.00	53.0%
2) Ending Balance, June 30 (E + F1e)			1,581,360.00	1,904,191.00	20.4%
Components of Ending Fund Balance					
a) Nonspendable					
Revolving Cash		9711	0.00	0.00	0.0%
Stores		9712	0.00	0.00	0.0%
Prepaid Items		9713	0.00	0.00	0.0%
All Others		9719	0.00	0.00	0.0%
b) Restricted		9740	1,581,455.00	1,904,315.00	20.4%
c) Committed					
Stabilization Arrangements		9750	0.00	0.00	0.0%
Other Commitments (by Resource/Object)		9760	0.00	0.00	0.0%
d) Assigned					
Other Assignments (by Resource/Object)		9780	0.00	0.00	0.0%
e) Unassigned/Unappropriated					
Reserve for Economic Uncertainties		9789	0.00	0.00	0.0%
Unassigned/Unappropriated Amount		9790	0.00	0.00	0.0%

Description	Resource Codes	Object Codes	2021-22 Estimated Actuals	2022-23 Budget	Percent Difference
A. REVENUES					
1) LCFF Sources		8010-8099	0.00	0.00	0.0%
2) Federal Revenue		8100-8299	0.00	0.00	0.0%
3) Other State Revenue		8300-8599	0.00	0.00	0.0%
4) Other Local Revenue		8600-8799	91,513.00	52,000.00	-43.2%
5) TOTAL, REVENUES			91,513.00	52,000.00	-43.2%
B. EXPENDITURES					
1) Certificated Salaries		1000-1999	0.00	0.00	0.0%
2) Classified Salaries		2000-2999	58,944.00	64,132.00	8.8%
3) Employee Benefits		3000-3999	42,398.00	48,965.00	15.5%
4) Books and Supplies		4000-4999	5,000.00	5,250.00	5.0%
5) Services and Other Operating Expenditures		5000-5999	500,000.00	200,000.00	-60.0%
6) Capital Outlay		6000-6999	224,534.00	300,000.00	33.6%
7) Other Outgo (excluding Transfers of Indirect Costs)		7100-7299,7400-7499	0.00	0.00	0.0%
8) Other Outgo - Transfers of Indirect Costs		7300-7399	0.00	0.00	0.0%
9) TOTAL, EXPENDITURES			830,876.00	618,347.00	-25.6%
C. EXCESS (DEFICIENCY) OF REVENUES OVER EXPENDITURES BEFORE OTHER FINANCING SOURCES AND USES (A5 - B9)			(739,363.00)	(566,347.00)	-23.4%
D. OTHER FINANCING SOURCES/USES					
1) Interfund Transfers					
a) Transfers In		8900-8929	302,420.00	314,175.00	3.9%
b) Transfers Out		7600-7629	0.00	0.00	0.0%
2) Other Sources/Uses					
a) Sources		8930-8979	0.00	0.00	0.0%
b) Uses		7630-7699	0.00	0.00	0.0%
3) Contributions		8980-8999	0.00	0.00	0.0%
4) TOTAL, OTHER FINANCING SOURCES/USES			302,420.00	314,175.00	3.9%
E. NET INCREASE (DECREASE) IN FUND BALANCE (C + D4)			(436,943.00)	(252,172.00)	-42.3%
F. FUND BALANCE, RESERVES					
1) Beginning Fund Balance					
a) As of July 1 - Unaudited		9791	2,899,024.00	2,462,081.00	-15.1%
b) Audit Adjustments		9793	0.00	0.00	0.0%
c) As of July 1 - Audited (F1a + F1b)			2,899,024.00	2,462,081.00	-15.1%
d) Other Restatements		9795	0.00	0.00	0.0%
e) Adjusted Beginning Balance (F1c + F1d)			2,899,024.00	2,462,081.00	-15.1%
2) Ending Balance, June 30 (E + F1e)			2,462,081.00	2,209,909.00	-10.2%
Components of Ending Fund Balance					
a) Nonspendable					
Revolving Cash		9711	0.00	0.00	0.0%
Stores		9712	0.00	0.00	0.0%
Prepaid Items		9713	0.00	0.00	0.0%
All Others		9719	0.00	0.00	0.0%
b) Restricted		9740	302,113.00	342,113.00	13.2%
c) Committed					
Stabilization Arrangements		9750	0.00	0.00	0.0%
Other Commitments		9760	0.00	0.00	0.0%
d) Assigned					
Other Assignments		9780	2,159,968.00	0.00	-100.0%
e) Unassigned/Unappropriated Reserve for Economic Uncertainties		9789	0.00	0.00	0.0%
Unassigned/Unappropriated Amount		9790	0.00	1,867,796.00	New
G. ASSETS					
1) Cash					
a) in County Treasury		9110	0.00		
1) Fair Value Adjustment to Cash in County Treasury		9111	0.00		
b) in Banks		9120	0.00		

Description	Resource Codes	Object Codes	2021-22 Estimated Actuals	2022-23 Budget	Percent Difference
Unemployment Insurance		3501-3502	281.00	321.00	14.2%
Workers' Compensation		3601-3602	913.00	1,043.00	14.2%
OPEB, Allocated		3701-3702	0.00	0.00	0.0%
OPEB, Active Employees		3751-3752	0.00	0.00	0.0%
Other Employee Benefits		3901-3902	0.00	0.00	0.0%
TOTAL, EMPLOYEE BENEFITS			42,398.00	48,965.00	15.5%
BOOKS AND SUPPLIES					
Books and Other Reference Materials		4200	0.00	0.00	0.0%
Materials and Supplies		4300	5,000.00	5,250.00	5.0%
Noncapitalized Equipment		4400	0.00	0.00	0.0%
TOTAL, BOOKS AND SUPPLIES			5,000.00	5,250.00	5.0%
SERVICES AND OTHER OPERATING EXPENDITURES					
Subagreements for Services		5100	0.00	0.00	0.0%
Travel and Conferences		5200	0.00	0.00	0.0%
Rentals, Leases, Repairs, and Noncapitalized Improvements		5600	434,326.00	200,000.00	-54.0%
Transfers of Direct Costs		5710	0.00	0.00	0.0%
Transfers of Direct Costs - Interfund		5750	0.00	0.00	0.0%
Professional/Consulting Services and Operating Expenditures		5800	65,674.00	0.00	-100.0%
TOTAL, SERVICES AND OTHER OPERATING EXPENDITURES			500,000.00	200,000.00	-60.0%
CAPITAL OUTLAY					
Land Improvements		6170	45,708.00	0.00	-100.0%
Buildings and Improvements of Buildings		6200	51,014.00	0.00	-100.0%
Equipment		6400	0.00	0.00	0.0%
Equipment Replacement		6500	127,812.00	300,000.00	134.7%
Lease Assets		6600	0.00	0.00	0.0%
TOTAL, CAPITAL OUTLAY			224,534.00	300,000.00	33.6%
OTHER OUTGO (excluding Transfers of Indirect Costs)					
Debt Service					
Debt Service - Interest		7438	0.00	0.00	0.0%
Other Debt Service - Principal		7439	0.00	0.00	0.0%
TOTAL, OTHER OUTGO (excluding Transfers of Indirect Costs)			0.00	0.00	0.0%
TOTAL, EXPENDITURES			830,876.00	618,347.00	-25.6%
INTERFUND TRANSFERS					
INTERFUND TRANSFERS IN					
Other Authorized Interfund Transfers In		8919	302,420.00	314,175.00	3.9%
(a) TOTAL, INTERFUND TRANSFERS IN			302,420.00	314,175.00	3.9%
INTERFUND TRANSFERS OUT					
Other Authorized Interfund Transfers Out		7619	0.00	0.00	0.0%
(b) TOTAL, INTERFUND TRANSFERS OUT			0.00	0.00	0.0%
OTHER SOURCES/USES					
SOURCES					
Other Sources					
Transfers from Funds of Lapsed/Reorganized LEAs		8965	0.00	0.00	0.0%
Long-Term Debt Proceeds					
Proceeds from Leases		8972	0.00	0.00	0.0%
All Other Financing Sources		8979	0.00	0.00	0.0%
(c) TOTAL, SOURCES			0.00	0.00	0.0%
USES					
Transfers of Funds from Lapsed/Reorganized LEAs		7651	0.00	0.00	0.0%
All Other Financing Uses		7699	0.00	0.00	0.0%
(d) TOTAL, USES			0.00	0.00	0.0%
CONTRIBUTIONS					
Contributions from Unrestricted Revenues		8980	0.00	0.00	0.0%
Contributions from Restricted Revenues		8990	0.00	0.00	0.0%
(e) TOTAL, CONTRIBUTIONS			0.00	0.00	0.0%

Description	Function Codes	Object Codes	2021-22 Estimated Actuals	2022-23 Budget	Percent Difference
A. REVENUES					
1) LCFF Sources		8010-8099	0.00	0.00	0.0%
2) Federal Revenue		8100-8299	0.00	0.00	0.0%
3) Other State Revenue		8300-8599	0.00	0.00	0.0%
4) Other Local Revenue		8600-8799	91,513.00	52,000.00	-43.2%
5) TOTAL, REVENUES			91,513.00	52,000.00	-43.2%
B. EXPENDITURES (Objects 1000-7999)					
1) Instruction	1000-1999		0.00	0.00	0.0%
2) Instruction - Related Services	2000-2999		0.00	0.00	0.0%
3) Pupil Services	3000-3999		0.00	0.00	0.0%
4) Ancillary Services	4000-4999		0.00	0.00	0.0%
5) Community Services	5000-5999		0.00	0.00	0.0%
6) Enterprise	6000-6999		0.00	0.00	0.0%
7) General Administration	7000-7999		-416.00	0.00	-100.0%
8) Plant Services	8000-8999		829,958.00	618,347.00	-25.5%
9) Other Outgo	9000-9999	Except 7600-7699	0.00	0.00	0.0%
10) TOTAL, EXPENDITURES			830,374.00	618,347.00	-25.5%
C. EXCESS (DEFICIENCY) OF REVENUES OVER EXPENDITURES BEFORE OTHER FINANCING SOURCES AND USES (A5 - B10)			(738,861.00)	(566,347.00)	-23.3%
D. OTHER FINANCING SOURCES/USES					
1) Interfund Transfers					
a) Transfers In		8900-8929	302,420.00	314,175.00	3.9%
b) Transfers Out		7600-7629	0.00	0.00	0.0%
2) Other Sources/Uses					
a) Sources		8930-8979	0.00	0.00	0.0%
b) Uses		7630-7699	0.00	0.00	0.0%
3) Contributions		8980-8999	0.00	0.00	0.0%
4) TOTAL, OTHER FINANCING SOURCES/USES			302,420.00	314,175.00	3.9%
E. NET INCREASE (DECREASE) IN FUND BALANCE (C + D4)			(436,441.00)	(252,172.00)	-42.2%
F. FUND BALANCE, RESERVES					
1) Beginning Fund Balance					
a) As of July 1 - Unaudited		9791	2,899,024.00	2,462,081.00	-15.1%
b) Audit Adjustments		9793	0.00	0.00	0.0%
c) As of July 1 - Audited (F1a + F1b)			2,899,024.00	2,462,081.00	-15.1%
d) Other Restatements		9795	0.00	0.00	0.0%
e) Adjusted Beginning Balance (F1c + F1d)			2,899,024.00	2,462,081.00	-15.1%
2) Ending Balance, June 30 (E + F1e)					
Components of Ending Fund Balance					
a) Nonspendable					
Revolving Cash		9711	0.00	0.00	0.0%
Stores		9712	0.00	0.00	0.0%
Prepaid Items		9713	0.00	0.00	0.0%
All Others		9719	0.00	0.00	0.0%
b) Restricted		9740	302,113.00	342,113.00	13.2%
c) Committed					
Stabilization Arrangements		9750	0.00	0.00	0.0%
Other Commitments (by Resource/Object)		9760	0.00	0.00	0.0%
d) Assigned					
Other Assignments (by Resource/Object)		9780	2,159,968.00	0.00	-100.0%
e) Unassigned/Unappropriated					
Reserve for Economic Uncertainties		9789	0.00	0.00	0.0%
Unassigned/Unappropriated Amount		9790	0.00	1,867,796.00	New

Description	Resource Codes	Object Codes	2021-22 Estimated Actuals	2022-23 Budget	Percent Difference
A. REVENUES					
1) LCFF Sources		8010-8099	0.00	0.00	0.0%
2) Federal Revenue		8100-8299	0.00	0.00	0.0%
3) Other State Revenue		8300-8599	0.00	0.00	0.0%
4) Other Local Revenue		8600-8799	161,338.00	128,764.00	-20.2%
5) TOTAL, REVENUES			161,338.00	128,764.00	-20.2%
B. EXPENDITURES					
1) Certificated Salaries		1000-1999	0.00	0.00	0.0%
2) Classified Salaries		2000-2999	82,516.00	88,753.00	7.6%
3) Employee Benefits		3000-3999	36,994.00	42,507.00	14.9%
4) Books and Supplies		4000-4999	0.00	0.00	0.0%
5) Services and Other Operating Expenditures		5000-5999	511,974.00	233,667.00	-54.4%
6) Capital Outlay		6000-6999	11,600,021.00	7,542,523.00	-35.0%
7) Other Outgo (excluding Transfers of Indirect Costs)		7100-7299, 7400-7499	0.00	0.00	0.0%
8) Other Outgo - Transfers of Indirect Costs		7300-7399	0.00	0.00	0.0%
9) TOTAL, EXPENDITURES			12,231,505.00	7,907,450.00	-35.4%
C. EXCESS (DEFICIENCY) OF REVENUES OVER EXPENDITURES BEFORE OTHER FINANCING SOURCES AND USES (A5 - B9)			(12,070,167.00)	(7,778,686.00)	-35.6%
D. OTHER FINANCING SOURCES/USES					
1) Interfund Transfers					
a) Transfers In		8900-8929	0.00	0.00	0.0%
b) Transfers Out		7600-7629	0.00	0.00	0.0%
2) Other Sources/Uses					
a) Sources		8930-8979	0.00	0.00	0.0%
b) Uses		7630-7699	0.00	0.00	0.0%
3) Contributions		8980-8999	0.00	0.00	0.0%
4) TOTAL, OTHER FINANCING SOURCES/USES			0.00	0.00	0.0%
E. NET INCREASE (DECREASE) IN FUND BALANCE (C + D4)			(12,070,167.00)	(7,778,686.00)	-35.6%
F. FUND BALANCE, RESERVES					
1) Beginning Fund Balance					
a) As of July 1 - Unaudited		9791	29,956,616.00	17,886,449.00	-40.3%
b) Audit Adjustments		9793	0.00	0.00	0.0%
c) As of July 1 - Audited (F1a + F1b)			29,956,616.00	17,886,449.00	-40.3%
d) Other Restatements		9795	0.00	0.00	0.0%
e) Adjusted Beginning Balance (F1c + F1d)			29,956,616.00	17,886,449.00	-40.3%
2) Ending Balance, June 30 (E + F1e)			17,886,449.00	10,107,763.00	-43.5%
Components of Ending Fund Balance					
a) Nonspendable					
Revolving Cash		9711	0.00	0.00	0.0%
Stores		9712	0.00	0.00	0.0%
Prepaid Items		9713	0.00	0.00	0.0%
All Others		9719	0.00	0.00	0.0%
b) Restricted					
		9740	0.00	0.00	0.0%
c) Committed					
Stabilization Arrangements		9750	0.00	0.00	0.0%
Other Commitments		9760	0.00	0.00	0.0%
d) Assigned					
Other Assignments		9780	17,886,449.00	0.00	-100.0%
e) Unassigned/Unappropriated					
Reserve for Economic Uncertainties		9789	0.00	0.00	0.0%
Unassigned/Unappropriated Amount		9790	0.00	10,107,763.00	New
G. ASSETS					
1) Cash					
a) in County Treasury		9110	0.00		
1) Fair Value Adjustment to Cash in County Treasury		9111	0.00		

Description	Resource Codes	Object Codes	2021-22 Estimated Actuals	2022-23 Budget	Percent Difference
Net Increase (Decrease) in the Fair Value of Investments		8662	0.00	0.00	0.0%
Other Local Revenue					
All Other Local Revenue		8699	44,280.00	0.00	-100.0%
All Other Transfers In from All Others		8799	0.00	0.00	0.0%
TOTAL, OTHER LOCAL REVENUE			161,338.00	128,764.00	-20.2%
TOTAL, REVENUES			161,338.00	128,764.00	-20.2%
CLASSIFIED SALARIES					
Classified Support Salaries		2200	0.00	0.00	0.0%
Classified Supervisors' and Administrators' Salaries		2300	82,516.00	88,753.00	7.6%
Clerical, Technical and Office Salaries		2400	0.00	0.00	0.0%
Other Classified Salaries		2900	0.00	0.00	0.0%
TOTAL, CLASSIFIED SALARIES			82,516.00	88,753.00	7.6%
EMPLOYEE BENEFITS					
STRS		3101-3102	0.00	0.00	0.0%
PERS		3201-3202	19,289.00	22,517.00	16.7%
OASDI/Medicare/Alternative		3301-3302	6,052.00	6,834.00	12.9%
Health and Welfare Benefits		3401-3402	9,981.00	11,268.00	12.9%
Unemployment Insurance		3501-3502	393.00	444.00	13.0%
Workers' Compensation		3601-3602	1,279.00	1,444.00	12.9%
OPEB, Allocated		3701-3702	0.00	0.00	0.0%
OPEB, Active Employees		3751-3752	0.00	0.00	0.0%
Other Employee Benefits		3901-3902	0.00	0.00	0.0%
TOTAL, EMPLOYEE BENEFITS			36,994.00	42,507.00	14.9%
BOOKS AND SUPPLIES					
Books and Other Reference Materials		4200	0.00	0.00	0.0%
Materials and Supplies		4300	0.00	0.00	0.0%
Noncapitalized Equipment		4400	0.00	0.00	0.0%
TOTAL, BOOKS AND SUPPLIES			0.00	0.00	0.0%
SERVICES AND OTHER OPERATING EXPENDITURES					
Subagreements for Services		5100	0.00	0.00	0.0%
Travel and Conferences		5200	0.00	0.00	0.0%
Insurance		5400-5450	286,346.00	0.00	-100.0%
Operations and Housekeeping Services		5500	0.00	0.00	0.0%
Rentals, Leases, Repairs, and Noncapitalized Improvements		5600	89,739.00	82,600.00	-8.0%
Transfers of Direct Costs		5710	0.00	0.00	0.0%
Transfers of Direct Costs - Interfund		5750	58,000.00	65,000.00	12.1%
Professional/Consulting Services and Operating Expenditures		5800	77,889.00	86,067.00	10.5%
Communications		5900	0.00	0.00	0.0%
TOTAL, SERVICES AND OTHER OPERATING EXPENDITURES			511,974.00	233,667.00	-54.4%
CAPITAL OUTLAY					
Land		6100	0.00	0.00	0.0%
Land Improvements		6170	0.00	0.00	0.0%
Buildings and Improvements of Buildings		6200	11,598,481.00	7,342,523.00	-36.7%
Books and Media for New School Libraries or Major Expansion of School Libraries		6300	0.00	0.00	0.0%
Equipment		6400	1,540.00	0.00	-100.0%
Equipment Replacement		6500	0.00	200,000.00	New
Lease Assets		6600	0.00	0.00	0.0%
TOTAL, CAPITAL OUTLAY			11,600,021.00	7,542,523.00	-35.0%
OTHER OUTGO (excluding Transfers of Indirect Costs)					
Other Transfers Out					
All Other Transfers Out to All Others		7299	0.00	0.00	0.0%
Debt Service					
Repayment of State School Building Fund Aid - Proceeds from Bonds		7435	0.00	0.00	0.0%
Debt Service - Interest		7438	0.00	0.00	0.0%
Other Debt Service - Principal		7439	0.00	0.00	0.0%

Description	Function Codes	Object Codes	2021-22 Estimated Actuals	2022-23 Budget	Percent Difference
A. REVENUES					
1) LCFF Sources		8010-8099	0.00	0.00	0.0%
2) Federal Revenue		8100-8299	0.00	0.00	0.0%
3) Other State Revenue		8300-8599	0.00	0.00	0.0%
4) Other Local Revenue		8600-8799	161,338.00	128,764.00	-20.2%
5) TOTAL, REVENUES			161,338.00	128,764.00	-20.2%
B. EXPENDITURES (Objects 1000-7999)					
1) Instruction	1000-1999		0.00	0.00	0.0%
2) Instruction - Related Services	2000-2999		0.00	0.00	0.0%
3) Pupil Services	3000-3999		0.00	0.00	0.0%
4) Ancillary Services	4000-4999		0.00	0.00	0.0%
5) Community Services	5000-5999		0.00	0.00	0.0%
6) Enterprise	6000-6999		0.00	0.00	0.0%
7) General Administration	7000-7999		0.00	0.00	0.0%
8) Plant Services	8000-8999		12,231,505.00	7,907,450.00	-35.4%
9) Other Outgo	9000-9999	Except 7600-7699	0.00	0.00	0.0%
10) TOTAL, EXPENDITURES			12,231,505.00	7,907,450.00	-35.4%
C. EXCESS (DEFICIENCY) OF REVENUES OVER EXPENDITURES BEFORE OTHER FINANCING SOURCES AND USES(A5 -B10)			(12,070,167.00)	(7,778,686.00)	-35.6%
D. OTHER FINANCING SOURCES/USES					
1) Interfund Transfers					
a) Transfers In		8900-8929	0.00	0.00	0.0%
b) Transfers Out		7600-7629	0.00	0.00	0.0%
2) Other Sources/Uses					
a) Sources		8930-8979	0.00	0.00	0.0%
b) Uses		7630-7699	0.00	0.00	0.0%
3) Contributions		8980-8999	0.00	0.00	0.0%
4) TOTAL, OTHER FINANCING SOURCES/USES			0.00	0.00	0.0%
E. NET INCREASE (DECREASE) IN FUND BALANCE(C + D4)			(12,070,167.00)	(7,778,686.00)	-35.6%
F. FUND BALANCE, RESERVES					
1) Beginning Fund Balance					
a) As of July 1 - Unaudited		9791	29,956,616.00	17,886,449.00	-40.3%
b) Audit Adjustments		9793	0.00	0.00	0.0%
c) As of July 1 - Audited (F1a + F1b)			29,956,616.00	17,886,449.00	-40.3%
d) Other Restatements		9795	0.00	0.00	0.0%
e) Adjusted Beginning Balance (F1c + F1d)			29,956,616.00	17,886,449.00	-40.3%
2) Ending Balance, June 30 (E + F1e)			17,886,449.00	10,107,763.00	-43.5%
Components of Ending Fund Balance					
a) Nonspendable					
Revolving Cash		9711	0.00	0.00	0.0%
Stores		9712	0.00	0.00	0.0%
Prepaid Items		9713	0.00	0.00	0.0%
All Others		9719	0.00	0.00	0.0%
b) Restricted					
		9740	0.00	0.00	0.0%
c) Committed					
Stabilization Arrangements		9750	0.00	0.00	0.0%
Other Commitments (by Resource/Object)		9760	0.00	0.00	0.0%
d) Assigned					
Other Assignments (by Resource/Object)		9780	17,886,449.00	0.00	-100.0%
e) Unassigned/Unappropriated					
Reserve for Economic Uncertainties		9789	0.00	0.00	0.0%
Unassigned/Unappropriated Amount		9790	0.00	10,107,763.00	New

Description	Resource Codes	Object Codes	2021-22 Estimated Actuals	2022-23 Budget	Percent Difference
A. REVENUES					
1) LCFF Sources		8010-8099	0.00	0.00	0.0%
2) Federal Revenue		8100-8299	0.00	0.00	0.0%
3) Other State Revenue		8300-8599	0.00	0.00	0.0%
4) Other Local Revenue		8600-8799	36,709.00	20,200.00	-45.0%
5) TOTAL, REVENUES			36,709.00	20,200.00	-45.0%
B. EXPENDITURES					
1) Certificated Salaries		1000-1999	0.00	0.00	0.0%
2) Classified Salaries		2000-2999	0.00	0.00	0.0%
3) Employee Benefits		3000-3999	0.00	0.00	0.0%
4) Books and Supplies		4000-4999	0.00	0.00	0.0%
5) Services and Other Operating Expenditures		5000-5999	1,000.00	200.00	-80.0%
6) Capital Outlay		6000-6999	1,000,000.00	0.00	-100.0%
7) Other Outgo (excluding Transfers of Indirect Costs)		7100-7299, 7400-7499	0.00	0.00	0.0%
8) Other Outgo - Transfers of Indirect Costs		7300-7399	0.00	0.00	0.0%
9) TOTAL, EXPENDITURES			1,001,000.00	200.00	-100.0%
C. EXCESS (DEFICIENCY) OF REVENUES OVER EXPENDITURES BEFORE OTHER FINANCING SOURCES AND USES (A5 - B9)			(964,291.00)	20,000.00	-102.1%
D. OTHER FINANCING SOURCES/USES					
1) Interfund Transfers					
a) Transfers In		8900-8929	0.00	0.00	0.0%
b) Transfers Out		7600-7629	0.00	0.00	0.0%
2) Other Sources/Uses					
a) Sources		8930-8979	0.00	0.00	0.0%
b) Uses		7630-7699	0.00	0.00	0.0%
3) Contributions		8980-8999	0.00	0.00	0.0%
4) TOTAL, OTHER FINANCING SOURCES/USES			0.00	0.00	0.0%
E. NET INCREASE (DECREASE) IN FUND BALANCE (C + D4)			(964,291.00)	20,000.00	-102.1%
F. FUND BALANCE, RESERVES					
1) Beginning Fund Balance					
a) As of July 1 - Unaudited		9791	1,162,551.00	198,260.00	-82.9%
b) Audit Adjustments		9793	0.00	0.00	0.0%
c) As of July 1 - Audited (F1a + F1b)			1,162,551.00	198,260.00	-82.9%
d) Other Restatements		9795	0.00	0.00	0.0%
e) Adjusted Beginning Balance (F1c + F1d)			1,162,551.00	198,260.00	-82.9%
2) Ending Balance, June 30 (E + F1e)			198,260.00	218,260.00	10.1%
Components of Ending Fund Balance					
a) Nonspendable					
Revolving Cash		9711	0.00	0.00	0.0%
Stores		9712	0.00	0.00	0.0%
Prepaid Items		9713	0.00	0.00	0.0%
All Others		9719	0.00	0.00	0.0%
b) Restricted		9740	172,742.00	192,742.00	11.6%
c) Committed					
Stabilization Arrangements		9750	0.00	0.00	0.0%
Other Commitments		9760	0.00	0.00	0.0%
d) Assigned					
Other Assignments		9780	25,518.00	0.00	-100.0%
e) Unassigned/Unappropriated					
Reserve for Economic Uncertainties		9789	0.00	0.00	0.0%
Unassigned/Unappropriated Amount		9790	0.00	25,518.00	New
G. ASSETS					
1) Cash					
a) in County Treasury		9110	0.00		
1) Fair Value Adjustment to Cash in County Treasury		9111	0.00		

Description	Resource Codes	Object Codes	2021-22 Estimated Actuals	2022-23 Budget	Percent Difference
All Other Transfers In from All Others		8799	0.00	0.00	0.0%
TOTAL, OTHER LOCAL REVENUE			36,709.00	20,200.00	-45.0%
TOTAL, REVENUES			36,709.00	20,200.00	-45.0%
CERTIFICATED SALARIES					
Other Certificated Salaries		1900	0.00	0.00	0.0%
TOTAL, CERTIFICATED SALARIES			0.00	0.00	0.0%
CLASSIFIED SALARIES					
Classified Support Salaries		2200	0.00	0.00	0.0%
Classified Supervisors' and Administrators' Salaries		2300	0.00	0.00	0.0%
Clerical, Technical and Office Salaries		2400	0.00	0.00	0.0%
Other Classified Salaries		2900	0.00	0.00	0.0%
TOTAL, CLASSIFIED SALARIES			0.00	0.00	0.0%
EMPLOYEE BENEFITS					
STRS		3101-3102	0.00	0.00	0.0%
PERS		3201-3202	0.00	0.00	0.0%
OASDI/Medicare/Alternative		3301-3302	0.00	0.00	0.0%
Health and Welfare Benefits		3401-3402	0.00	0.00	0.0%
Unemployment Insurance		3501-3502	0.00	0.00	0.0%
Workers' Compensation		3601-3602	0.00	0.00	0.0%
OPEB, Allocated		3701-3702	0.00	0.00	0.0%
OPEB, Active Employees		3751-3752	0.00	0.00	0.0%
Other Employee Benefits		3901-3902	0.00	0.00	0.0%
TOTAL, EMPLOYEE BENEFITS			0.00	0.00	0.0%
BOOKS AND SUPPLIES					
Approved Textbooks and Core Curricula Materials		4100	0.00	0.00	0.0%
Books and Other Reference Materials		4200	0.00	0.00	0.0%
Materials and Supplies		4300	0.00	0.00	0.0%
Noncapitalized Equipment		4400	0.00	0.00	0.0%
TOTAL, BOOKS AND SUPPLIES			0.00	0.00	0.0%
SERVICES AND OTHER OPERATING EXPENDITURES					
Subagreements for Services		5100	0.00	0.00	0.0%
Travel and Conferences		5200	0.00	0.00	0.0%
Insurance		5400-5450	0.00	0.00	0.0%
Operations and Housekeeping Services		5500	0.00	0.00	0.0%
Rentals, Leases, Repairs, and Noncapitalized Improvements		5600	0.00	0.00	0.0%
Transfers of Direct Costs		5710	0.00	0.00	0.0%
Transfers of Direct Costs - Interfund		5750	0.00	0.00	0.0%
Professional/Consulting Services and Operating Expenditures		5800	1,000.00	200.00	-80.0%
Communications		5900	0.00	0.00	0.0%
TOTAL, SERVICES AND OTHER OPERATING EXPENDITURES			1,000.00	200.00	-80.0%
CAPITAL OUTLAY					
Land		6100	0.00	0.00	0.0%
Land Improvements		6170	0.00	0.00	0.0%
Buildings and Improvements of Buildings		6200	1,000,000.00	0.00	-100.0%
Books and Media for New School Libraries or Major Expansion of School Libraries		6300	0.00	0.00	0.0%
Equipment		6400	0.00	0.00	0.0%
Equipment Replacement		6500	0.00	0.00	0.0%
Lease Assets		6600	0.00	0.00	0.0%
TOTAL, CAPITAL OUTLAY			1,000,000.00	0.00	-100.0%
OTHER OUTGO (excluding Transfers of Indirect Costs)					
Other Transfers Out					
All Other Transfers Out to All Others		7299	0.00	0.00	0.0%
Debt Service					
Debt Service - Interest		7438	0.00	0.00	0.0%
Other Debt Service - Principal		7439	0.00	0.00	0.0%

Description	Function Codes	Object Codes	2021-22 Estimated Actuals	2022-23 Budget	Percent Difference
A. REVENUES					
1) LCFF Sources		8010-8099	0.00	0.00	0.0%
2) Federal Revenue		8100-8299	0.00	0.00	0.0%
3) Other State Revenue		8300-8599	0.00	0.00	0.0%
4) Other Local Revenue		8600-8799	36,709.00	20,200.00	-45.0%
5) TOTAL, REVENUES			36,709.00	20,200.00	-45.0%
B. EXPENDITURES (Objects 1000-7999)					
1) Instruction	1000-1999		0.00	0.00	0.0%
2) Instruction - Related Services	2000-2999		0.00	0.00	0.0%
3) Pupil Services	3000-3999		0.00	0.00	0.0%
4) Ancillary Services	4000-4999		0.00	0.00	0.0%
5) Community Services	5000-5999		0.00	0.00	0.0%
6) Enterprise	6000-6999		0.00	0.00	0.0%
7) General Administration	7000-7999		791.00	200.00	-74.7%
8) Plant Services	8000-8999		1,000,000.00	0.00	-100.0%
9) Other Outgo	9000-9999	Except 7600-7699	0.00	0.00	0.0%
10) TOTAL, EXPENDITURES			1,000,791.00	200.00	-100.0%
C. EXCESS (DEFICIENCY) OF REVENUES OVER EXPENDITURES BEFORE OTHER FINANCING SOURCES AND USES(A5 -B10)			(964,082.00)	20,000.00	-102.1%
D. OTHER FINANCING SOURCES/USES					
1) Interfund Transfers					
a) Transfers In		8900-8929	0.00	0.00	0.0%
b) Transfers Out		7600-7629	0.00	0.00	0.0%
2) Other Sources/Uses					
a) Sources		8930-8979	0.00	0.00	0.0%
b) Uses		7630-7699	0.00	0.00	0.0%
3) Contributions		8980-8999	0.00	0.00	0.0%
4) TOTAL, OTHER FINANCING SOURCES/USES			0.00	0.00	0.0%
E. NET INCREASE (DECREASE) IN FUND BALANCE(C + D4)			(964,082.00)	20,000.00	-102.1%
F. FUND BALANCE, RESERVES					
1) Beginning Fund Balance					
a) As of July 1 - Unaudited		9791	1,162,551.00	198,260.00	-82.9%
b) Audit Adjustments		9793	0.00	0.00	0.0%
c) As of July 1 - Audited (F1a + F1b)			1,162,551.00	198,260.00	-82.9%
d) Other Restatements		9795	0.00	0.00	0.0%
e) Adjusted Beginning Balance (F1c + F1d)			1,162,551.00	198,260.00	-82.9%
2) Ending Balance, June 30 (E + F1e)			198,469.00	218,260.00	10.0%
Components of Ending Fund Balance					
a) Nonspendable					
Revolving Cash		9711	0.00	0.00	0.0%
Stores		9712	0.00	0.00	0.0%
Prepaid Items		9713	0.00	0.00	0.0%
All Others		9719	0.00	0.00	0.0%
b) Restricted		9740	172,742.00	192,742.00	11.6%
c) Committed					
Stabilization Arrangements		9750	0.00	0.00	0.0%
Other Commitments (by Resource/Object)		9760	0.00	0.00	0.0%
d) Assigned					
Other Assignments (by Resource/Object)		9780	25,518.00	0.00	-100.0%
e) Unassigned/Unappropriated					
Reserve for Economic Uncertainties		9789	0.00	0.00	0.0%
Unassigned/Unappropriated Amount		9790	0.00	25,518.00	New

Description	Resource Codes	Object Codes	2021-22 Estimated Actuals	2022-23 Budget	Percent Difference
A. REVENUES					
1) LCFF Sources		8010-8099	0.00	0.00	0.0%
2) Federal Revenue		8100-8299	0.00	0.00	0.0%
3) Other State Revenue		8300-8599	3,405,000.00	0.00	-100.0%
4) Other Local Revenue		8600-8799	786,356.00	822,924.00	4.7%
5) TOTAL, REVENUES			4,191,356.00	822,924.00	-80.4%
B. EXPENDITURES					
1) Certificated Salaries		1000-1999	0.00	0.00	0.0%
2) Classified Salaries		2000-2999	0.00	0.00	0.0%
3) Employee Benefits		3000-3999	0.00	0.00	0.0%
4) Books and Supplies		4000-4999	19,400.00	0.00	-100.0%
5) Services and Other Operating Expenditures		5000-5999	164,244.00	137,000.00	-16.6%
6) Capital Outlay		6000-6999	157,582.00	89,221.00	-43.4%
7) Other Outgo (excluding Transfers of Indirect Costs)		7100-7299, 7400-7499	0.00	0.00	0.0%
8) Other Outgo - Transfers of Indirect Costs		7300-7399	0.00	0.00	0.0%
9) TOTAL, EXPENDITURES			341,226.00	226,221.00	-33.7%
C. EXCESS (DEFICIENCY) OF REVENUES OVER EXPENDITURES BEFORE OTHER FINANCING SOURCES AND USES (A5 - B9)			3,850,130.00	596,703.00	-84.5%
D. OTHER FINANCING SOURCES/USES					
1) Interfund Transfers					
a) Transfers In		8900-8929	0.00	0.00	0.0%
b) Transfers Out		7600-7629	0.00	0.00	0.0%
2) Other Sources/Uses					
a) Sources		8930-8979	0.00	0.00	0.0%
b) Uses		7630-7699	0.00	0.00	0.0%
3) Contributions		8980-8999	0.00	0.00	0.0%
4) TOTAL, OTHER FINANCING SOURCES/USES			0.00	0.00	0.0%
E. NET INCREASE (DECREASE) IN FUND BALANCE (C + D4)			3,850,130.00	596,703.00	-84.5%
F. FUND BALANCE, RESERVES					
1) Beginning Fund Balance					
a) As of July 1 - Unaudited		9791	9,858,213.00	13,708,343.00	39.1%
b) Audit Adjustments		9793	0.00	0.00	0.0%
c) As of July 1 - Audited (F1a + F1b)			9,858,213.00	13,708,343.00	39.1%
d) Other Restatements		9795	0.00	0.00	0.0%
e) Adjusted Beginning Balance (F1c + F1d)			9,858,213.00	13,708,343.00	39.1%
2) Ending Balance, June 30 (E + F1e)			13,708,343.00	14,305,046.00	4.4%
Components of Ending Fund Balance					
a) Nonspendable					
Revolving Cash		9711	0.00	0.00	0.0%
Stores		9712	0.00	0.00	0.0%
Prepaid Items		9713	0.00	0.00	0.0%
All Others		9719	0.00	0.00	0.0%
b) Restricted		9740	0.00	0.00	0.0%
c) Committed					
Stabilization Arrangements		9750	0.00	0.00	0.0%
Other Commitments		9760	0.00	0.00	0.0%
d) Assigned					
Other Assignments		9780	13,708,343.00	596,703.00	-95.6%
e) Unassigned/Unappropriated					
Reserve for Economic Uncertainties		9789	0.00	0.00	0.0%
Unassigned/Unappropriated Amount		9790	0.00	13,708,343.00	New
G. ASSETS					
1) Cash					
a) in County Treasury		9110	0.00		
1) Fair Value Adjustment to Cash in County Treasury		9111	0.00		

Description	Resource Codes	Object Codes	2021-22 Estimated Actuals	2022-23 Budget	Percent Difference
EMPLOYEE BENEFITS					
STRS		3101-3102	0.00	0.00	0.0%
PERS		3201-3202	0.00	0.00	0.0%
OASDI/Medicare/Alternative		3301-3302	0.00	0.00	0.0%
Health and Welfare Benefits		3401-3402	0.00	0.00	0.0%
Unemployment Insurance		3501-3502	0.00	0.00	0.0%
Workers' Compensation		3601-3602	0.00	0.00	0.0%
OPEB, Allocated		3701-3702	0.00	0.00	0.0%
OPEB, Active Employees		3751-3752	0.00	0.00	0.0%
Other Employee Benefits		3901-3902	0.00	0.00	0.0%
TOTAL, EMPLOYEE BENEFITS			0.00	0.00	0.0%
BOOKS AND SUPPLIES					
Books and Other Reference Materials		4200	0.00	0.00	0.0%
Materials and Supplies		4300	100.00	0.00	-100.0%
Noncapitalized Equipment		4400	19,300.00	0.00	-100.0%
TOTAL, BOOKS AND SUPPLIES			19,400.00	0.00	-100.0%
SERVICES AND OTHER OPERATING EXPENDITURES					
Subagreements for Services		5100	0.00	0.00	0.0%
Travel and Conferences		5200	0.00	0.00	0.0%
Insurance		5400-5450	0.00	0.00	0.0%
Operations and Housekeeping Services		5500	0.00	0.00	0.0%
Rentals, Leases, Repairs, and Noncapitalized Improvements		5600	0.00	0.00	0.0%
Transfers of Direct Costs		5710	0.00	0.00	0.0%
Transfers of Direct Costs - Interfund		5750	0.00	0.00	0.0%
Professional/Consulting Services and Operating Expenditures		5800	164,244.00	137,000.00	-16.6%
Communications		5900	0.00	0.00	0.0%
TOTAL, SERVICES AND OTHER OPERATING EXPENDITURES			164,244.00	137,000.00	-16.6%
CAPITAL OUTLAY					
Land		6100	0.00	0.00	0.0%
Land Improvements		6170	85,330.00	57,857.00	-32.2%
Buildings and Improvements of Buildings		6200	72,252.00	31,364.00	-56.6%
Books and Media for New School Libraries or Major Expansion of School Libraries		6300	0.00	0.00	0.0%
Equipment		6400	0.00	0.00	0.0%
Equipment Replacement		6500	0.00	0.00	0.0%
Lease Assets		6600	0.00	0.00	0.0%
TOTAL, CAPITAL OUTLAY			157,582.00	89,221.00	-43.4%
OTHER OUTGO (excluding Transfers of Indirect Costs)					
Other Transfers Out					
Transfers of Pass-Through Revenues					
To Districts or Charter Schools		7211	0.00	0.00	0.0%
To County Offices		7212	0.00	0.00	0.0%
To JPAs		7213	0.00	0.00	0.0%
All Other Transfers Out to All Others		7299	0.00	0.00	0.0%
Debt Service					
Debt Service - Interest		7438	0.00	0.00	0.0%
Other Debt Service - Principal		7439	0.00	0.00	0.0%
TOTAL, OTHER OUTGO (excluding Transfers of Indirect Costs)			0.00	0.00	0.0%
TOTAL, EXPENDITURES			341,226.00	226,221.00	-33.7%
INTERFUND TRANSFERS					
INTERFUND TRANSFERS IN					
To: Special Reserve Fund From: General Fund/CSSF		8912	0.00	0.00	0.0%
Other Authorized Interfund Transfers In		8919	0.00	0.00	0.0%
(a) TOTAL, INTERFUND TRANSFERS IN			0.00	0.00	0.0%
INTERFUND TRANSFERS OUT					
From: Special Reserve Fund To: General Fund/CSSF		7612	0.00	0.00	0.0%

Description	Function Codes	Object Codes	2021-22 Estimated Actuals	2022-23 Budget	Percent Difference
A. REVENUES					
1) LCFF Sources		8010-8099	0.00	0.00	0.0%
2) Federal Revenue		8100-8299	0.00	0.00	0.0%
3) Other State Revenue		8300-8599	3,405,000.00	0.00	-100.0%
4) Other Local Revenue		8600-8799	786,356.00	822,924.00	4.7%
5) TOTAL, REVENUES			4,191,356.00	822,924.00	-80.4%
B. EXPENDITURES (Objects 1000-7999)					
1) Instruction	1000-1999		0.00	0.00	0.0%
2) Instruction - Related Services	2000-2999		0.00	0.00	0.0%
3) Pupil Services	3000-3999		0.00	0.00	0.0%
4) Ancillary Services	4000-4999		0.00	0.00	0.0%
5) Community Services	5000-5999		0.00	0.00	0.0%
6) Enterprise	6000-6999		0.00	0.00	0.0%
7) General Administration	7000-7999		0.00	0.00	0.0%
8) Plant Services	8000-8999		334,226.00	219,221.00	-34.4%
9) Other Outgo	9000-9999	Except 7600-7699	0.00	0.00	0.0%
10) TOTAL, EXPENDITURES			334,226.00	219,221.00	-34.4%
C. EXCESS (DEFICIENCY) OF REVENUES OVER EXPENDITURES BEFORE OTHER FINANCING SOURCES AND USES(A5 -B10)			3,857,130.00	603,703.00	-84.3%
D. OTHER FINANCING SOURCES/USES					
1) Interfund Transfers					
a) Transfers In		8900-8929	0.00	0.00	0.0%
b) Transfers Out		7600-7629	0.00	0.00	0.0%
2) Other Sources/Uses					
a) Sources		8930-8979	0.00	0.00	0.0%
b) Uses		7630-7699	0.00	0.00	0.0%
3) Contributions		8980-8999	0.00	0.00	0.0%
4) TOTAL, OTHER FINANCING SOURCES/USES			0.00	0.00	0.0%
E. NET INCREASE (DECREASE) IN FUND BALANCE(C + D4)			3,857,130.00	603,703.00	-84.3%
F. FUND BALANCE, RESERVES					
1) Beginning Fund Balance					
a) As of July 1 - Unaudited		9791	9,858,213.00	13,708,343.00	39.1%
b) Audit Adjustments		9793	0.00	0.00	0.0%
c) As of July 1 - Audited (F1a + F1b)			9,858,213.00	13,708,343.00	39.1%
d) Other Restatements		9795	0.00	0.00	0.0%
e) Adjusted Beginning Balance (F1c + F1d)			9,858,213.00	13,708,343.00	39.1%
2) Ending Balance, June 30 (E + F1e)			13,715,343.00	14,312,046.00	4.4%
Components of Ending Fund Balance					
a) Nonspendable					
Revolving Cash		9711	0.00	0.00	0.0%
Stores		9712	0.00	0.00	0.0%
Prepaid Items		9713	0.00	0.00	0.0%
All Others		9719	0.00	0.00	0.0%
b) Restricted					
c) Committed					
Stabilization Arrangements		9750	0.00	0.00	0.0%
Other Commitments (by Resource/Object)		9760	0.00	0.00	0.0%
d) Assigned					
Other Assignments (by Resource/Object)		9780	13,708,343.00	596,703.00	-95.6%
e) Unassigned/Unappropriated					
Reserve for Economic Uncertainties		9789	0.00	0.00	0.0%
Unassigned/Unappropriated Amount		9790	0.00	13,708,343.00	New

Description	2021-22 Estimated Actuals			2022-23 Budget		
	P-2 ADA	Annual ADA	Funded ADA	Estimated P-2 ADA	Estimated Annual ADA	Estimated Funded ADA
A. DISTRICT						
1. Total District Regular ADA						
Includes Opportunity Classes, Home & Hospital, Special Day Class, Continuation Education, Special Education NPS/LCI and Extended Year, and Community Day School (includes Necessary Small School ADA)	2,894.04	2,890.00	3,056.49	2,939.40	2,935.00	3,000.00
2. Total Basic Aid Choice/Court Ordered Voluntary Pupil Transfer Regular ADA						
Includes Opportunity Classes, Home & Hospital, Special Day Class, Continuation Education, Special Education NPS/LCI and Extended Year, and Community Day School (ADA not included in Line A1 above)						
3. Total Basic Aid Open Enrollment Regular ADA						
Includes Opportunity Classes, Home & Hospital, Special Day Class, Continuation Education, Special Education NPS/LCI and Extended Year, and Community Day School (ADA not included in Line A1 above)						
4. Total, District Regular ADA (Sum of Lines A1 through A3)	2,894.04	2,890.00	3,056.49	2,939.40	2,935.00	3,000.00
5. District Funded County Program ADA						
a. County Community Schools	2.32	2.32	2.32	2.51	2.51	2.51
b. Special Education-Special Day Class						
c. Special Education-NPS/LCI						
d. Special Education Extended Year						
e. Other County Operated Programs: Opportunity Schools and Full Day Opportunity Classes, Specialized Secondary Schools						
f. County School Tuition Fund (Out of State Tuition) [EC 2000 and 46380]						
g. Total, District Funded County Program ADA (Sum of Lines A5a through A5f)	2.32	2.32	2.32	2.51	2.51	2.51
6. TOTAL DISTRICT ADA (Sum of Line A4 and Line A5g)	2,896.36	2,892.32	3,058.81	2,941.91	2,937.51	3,002.51
7. Adults in Correctional Facilities						
8. Charter School ADA (Enter Charter School ADA using Tab C. Charter School ADA)						

Description	2021-22 Estimated Actuals			2022-23 Budget		
	P-2 ADA	Annual ADA	Funded ADA	Estimated P-2 ADA	Estimated Annual ADA	Estimated Funded ADA
B. COUNTY OFFICE OF EDUCATION						
1. County Program Alternative Education Grant ADA						
a. County Group Home and Institution Pupils						
b. Juvenile Halls, Homes, and Camps						
c. Probation Referred, On Probation or Parole, Expelled per EC 48915(a) or (c) [EC 2574(c)(4)(A)]						
d. Total, County Program Alternative Education ADA (Sum of Lines B1a through B1c)	0.00	0.00	0.00	0.00	0.00	0.00
2. District Funded County Program ADA						
a. County Community Schools						
b. Special Education-Special Day Class						
c. Special Education-NPS/LCI						
d. Special Education Extended Year						
e. Other County Operated Programs: Opportunity Schools and Full Day Opportunity Classes, Specialized Secondary Schools						
f. County School Tuition Fund (Out of State Tuition) (EC 2000 and 46380)						
g. Total, District Funded County Program ADA (Sum of Lines B2a through B2f)	0.00	0.00	0.00	0.00	0.00	0.00
3. TOTAL COUNTY OFFICE ADA (Sum of Lines B1d and B2g)	0.00	0.00	0.00	0.00	0.00	0.00
4. Adults in Correctional Facilities						
5. County Operations Grant ADA						
6. Charter School ADA (Enter Charter School ADA using Tab C. Charter School ADA)						

Description	2021-22 Estimated Actuals			2022-23 Budget		
	P-2 ADA	Annual ADA	Funded ADA	Estimated P-2 ADA	Estimated Annual ADA	Estimated Funded ADA
C. CHARTER SCHOOL ADA						
Authorizing LEAs reporting charter school SACS financial data in their Fund 01, 09, or 62 use this worksheet to report ADA for those charter schools.						
Charter schools reporting SACS financial data separately from their authorizing LEAs in Fund 01 or Fund 62 use this worksheet to report their ADA.						
FUND 01: Charter School ADA corresponding to SACS financial data reported in Fund 01.						
1. Total Charter School Regular ADA						
2. Charter School County Program Alternative Education ADA						
a. County Group Home and Institution Pupils						
b. Juvenile Halls, Homes, and Camps						
c. Probation Referred, On Probation or Parole, Expelled per EC 48915(a) or (c) [EC 2574(c)(4)(A)]						
d. Total, Charter School County Program Alternative Education ADA (Sum of Lines C2a through C2c)	0.00	0.00	0.00	0.00	0.00	0.00
3. Charter School Funded County Program ADA						
a. County Community Schools						
b. Special Education-Special Day Class						
c. Special Education-NPS/LCI						
d. Special Education Extended Year						
e. Other County Operated Programs: Opportunity Schools and Full Day Opportunity Classes, Specialized Secondary Schools						
f. Total, Charter School Funded County Program ADA (Sum of Lines C3a through C3e)	0.00	0.00	0.00	0.00	0.00	0.00
4. TOTAL CHARTER SCHOOL ADA (Sum of Lines C1, C2d, and C3f)	0.00	0.00	0.00	0.00	0.00	0.00
FUND 09 or 62: Charter School ADA corresponding to SACS financial data reported in Fund 09 or Fund 62.						
5. Total Charter School Regular ADA						
6. Charter School County Program Alternative Education ADA						
a. County Group Home and Institution Pupils						
b. Juvenile Halls, Homes, and Camps						
c. Probation Referred, On Probation or Parole, Expelled per EC 48915(a) or (c) [EC 2574(c)(4)(A)]						
d. Total, Charter School County Program Alternative Education ADA (Sum of Lines C6a through C6c)	0.00	0.00	0.00	0.00	0.00	0.00
7. Charter School Funded County Program ADA						
a. County Community Schools						
b. Special Education-Special Day Class						
c. Special Education-NPS/LCI						
d. Special Education Extended Year						
e. Other County Operated Programs: Opportunity Schools and Full Day Opportunity Classes, Specialized Secondary Schools						
f. Total, Charter School Funded County Program ADA (Sum of Lines C7a through C7e)	0.00	0.00	0.00	0.00	0.00	0.00
8. TOTAL CHARTER SCHOOL ADA (Sum of Lines C5, C6d, and C7f)	0.00	0.00	0.00	0.00	0.00	0.00
9. TOTAL CHARTER SCHOOL ADA Reported in Fund 01, 09, or 62 (Sum of Lines C4 and C8)	0.00	0.00	0.00	0.00	0.00	0.00

Description	Object Codes	2022-23 Budget (Form 01) (A)	% Change (Cols. C-A/A) (B)	2023-24 Projection (C)	% Change (Cols. E-C/C) (D)	2024-25 Projection (E)
(Enter projections for subsequent years 1 and 2 in Columns C and E; current year - Column A - is extracted)						
A. REVENUES AND OTHER FINANCING SOURCES						
1. LCFF/Revenue Limit Sources	8010-8099	30,836,281.00	5.68%	32,588,218.00	3.56%	33,747,218.00
2. Federal Revenues	8100-8299	2,373,272.00	0.00%	2,373,272.00	0.00%	2,373,272.00
3. Other State Revenues	8300-8599	970,670.00	0.00%	970,670.00	0.00%	970,670.00
4. Other Local Revenues	8600-8799	3,204,644.00	-5.93%	3,014,644.00	0.00%	3,014,644.00
5. Other Financing Sources						
a. Transfers In	8900-8929	0.00	0.00%	0.00	0.00%	0.00
b. Other Sources	8930-8979	0.00	0.00%	0.00	0.00%	0.00
c. Contributions	8980-8999	0.00	0.00%	0.00	0.00%	0.00
6. Total (Sum lines A1 thru A5c)		37,384,867.00	4.18%	38,946,804.00	2.98%	40,105,804.00
B. EXPENDITURES AND OTHER FINANCING USES						
1. Certificated Salaries						
a. Base Salaries				17,427,045.00		17,790,045.00
b. Step & Column Adjustment				328,000.00		328,000.00
c. Cost-of-Living Adjustment				0.00		0.00
d. Other Adjustments				35,000.00		35,000.00
e. Total Certificated Salaries (Sum lines B1a thru B1d)	1000-1999	17,427,045.00	2.08%	17,790,045.00	2.04%	18,153,045.00
2. Classified Salaries						
a. Base Salaries				6,016,319.00		6,106,319.00
b. Step & Column Adjustment				90,000.00		90,000.00
c. Cost-of-Living Adjustment				0.00		0.00
d. Other Adjustments				0.00		0.00
e. Total Classified Salaries (Sum lines B2a thru B2d)	2000-2999	6,016,319.00	1.50%	6,106,319.00	1.47%	6,196,319.00
3. Employee Benefits	3000-3999	10,641,722.00	3.08%	10,969,722.00	3.15%	11,314,722.00
4. Books and Supplies	4000-4999	1,691,230.00	-24.55%	1,275,987.00	16.30%	1,483,987.00
5. Services and Other Operating Expenditures	5000-5999	2,543,759.00	5.78%	2,690,759.00	8.18%	2,910,759.00
6. Capital Outlay	6000-6999	11,970.00	0.00%	11,970.00	0.00%	11,970.00
7. Other Outgo (excluding Transfers of Indirect Costs)	7100-7299, 7400-7499	349,152.00	0.00%	349,152.00	0.00%	349,152.00
8. Other Outgo - Transfers of Indirect Costs	7300-7399	(151,520.00)	0.00%	(151,520.00)	0.00%	(151,520.00)
9. Other Financing Uses						
a. Transfers Out	7600-7629	0.00	0.00%	0.00	0.00%	0.00
b. Other Uses	7630-7699	0.00	0.00%	0.00	0.00%	0.00
10. Other Adjustments				0.00		0.00
11. Total (Sum lines B1 thru B10)		38,529,677.00	1.33%	39,042,434.00	3.14%	40,268,434.00

Description	Object Codes	2022-23 Budget (Form 01) (A)	% Change (Cols. C-A/A) (B)	2023-24 Projection (C)	% Change (Cols. E-C/C) (D)	2024-25 Projection (E)
C. NET INCREASE (DECREASE) IN FUND BALANCE (Line A6 minus line B11)						
		(1,144,810.00)		(95,630.00)		(162,630.00)
D. FUND BALANCE						
1. Net Beginning Fund Balance (Form 01, line F1e)						
		12,050,905.00		10,906,095.00		10,810,465.00
2. Ending Fund Balance (Sum lines C and D1)						
		10,906,095.00		10,810,465.00		10,647,835.00
3. Components of Ending Fund Balance						
a. Nonspendable	9710-9719	10,000.00		10,000.00		10,000.00
b. Restricted	9740	1,211,776.00		1,211,776.00		1,211,776.00
c. Committed						
1. Stabilization Arrangements	9750	0.00		0.00		0.00
2. Other Commitments	9760	0.00		0.00		0.00
d. Assigned	9780	0.00		0.00		0.00
e. Unassigned/Unappropriated						
1. Reserve for Economic Uncertainties	9789	0.00		0.00		0.00
2. Unassigned/Unappropriated	9790	9,684,319.00		9,588,689.00		9,426,059.00
f. Total Components of Ending Fund Balance (Line D3f must agree with line D2)		10,906,095.00		10,810,465.00		10,647,835.00
E. AVAILABLE RESERVES						
1. General Fund						
a. Stabilization Arrangements	9750	0.00		0.00		0.00
b. Reserve for Economic Uncertainties	9789	0.00		0.00		0.00
c. Unassigned/Unappropriated	9790	9,684,319.00		9,588,689.00		9,426,059.00
d. Negative Restricted Ending Balances (Negative resources 2000-9999)	979Z			0.00		0.00
2. Special Reserve Fund - Noncapital Outlay (Fund 17)						
a. Stabilization Arrangements	9750	0.00		0.00		0.00
b. Reserve for Economic Uncertainties	9789	0.00		0.00		0.00
c. Unassigned/Unappropriated	9790	0.00		0.00		0.00
3. Total Available Reserves - by Amount (Sum lines E1a thru E2c)		9,684,319.00		9,588,689.00		9,426,059.00
4. Total Available Reserves - by Percent (Line E3 divided by Line F3c)		25.13%		24.56%		23.41%
F. RECOMMENDED RESERVES						
1. Special Education Pass-through Exclusions						
For districts that serve as the administrative unit (AU) of a special education local plan area (SELPA):						

Description	Object Codes	2022-23 Budget (Form 01) (A)	% Change (Cols. C-A/A) (B)	2023-24 Projection (C)	% Change (Cols. E-C/C) (D)	2024-25 Projection (E)
a. Do you choose to exclude from the reserve calculation the pass-through funds distributed to SELPA members?	Yes					
b. If you are the SELPA AU and are excluding special education pass-through funds:						
1. Enter the name(s) of the SELPA(s):						
2. Special education pass-through funds (Column A; Fund 10, resources 3300-3499, 6500-6540 and 6546, objects 7211-7213 and 7221-7223; enter projections for subsequent years 1 and 2 in Columns C and E)		0.00				
2. District ADA						
Used to determine the reserve standard percentage level on line F3d (Col. A: Form A, Estimated P-2 ADA column, Lines A4 and C4; enter projections)		2,939.40		3,000.00		3,000.00
3. Calculating the Reserves						
a. Expenditures and Other Financing Uses (Line B11)		38,529,677.00		39,042,434.00		40,268,434.00
b. Plus: Special Education Pass-through Funds (Line F1b2, if Line F1a is No)		0.00		0.00		0.00
c. Total Expenditures and Other Financing Uses (Line F3a plus line F3b)		38,529,677.00		39,042,434.00		40,268,434.00
d. Reserve Standard Percentage Level (Refer to Form 01CS, Criterion 10 for calculation details)		3.00%		3.00%		3.00%
e. Reserve Standard - By Percent (Line F3c times F3d)		1,155,890.31		1,171,273.02		1,208,053.02
f. Reserve Standard - By Amount (Refer to Form 01CS, Criterion 10 for calculation details)		0.00		0.00		0.00
g. Reserve Standard (Greater of Line F3e or F3f)		1,155,890.31		1,171,273.02		1,208,053.02
h. Available Reserves (Line E3) Meet Reserve Standard (Line F3g)		YES		YES		YES

Description	Object Codes	2022-23 Budget (Form 01) (A)	% Change (Cols. C-A/A) (B)	2023-24 Projection (C)	% Change (Cols. E-C/C) (D)	2024-25 Projection (E)
(Enter projections for subsequent years 1 and 2 in Columns C and E; current year - Column A - is extracted)						
A. REVENUES AND OTHER FINANCING SOURCES						
1. LCFF/Revenue Limit Sources	8010-8099	30,836,281.00	5.68%	32,588,218.00	3.56%	33,747,218.00
2. Federal Revenues	8100-8299	0.00	0.00%	0.00	0.00%	0.00
3. Other State Revenues	8300-8599	603,692.00	0.00%	603,692.00	0.00%	603,692.00
4. Other Local Revenues	8600-8799	85,000.00	0.00%	85,000.00	0.00%	85,000.00
5. Other Financing Sources						
a. Transfers In	8900-8929	0.00	0.00%		0.00%	
b. Other Sources	8930-8979	0.00	0.00%		0.00%	
c. Contributions	8980-8999	(4,094,655.00)	4.64%	(4,284,655.00)	0.00%	(4,284,655.00)
6. Total (Sum lines A1 thru A5c)		27,430,318.00	5.69%	28,992,255.00	4.00%	30,151,255.00
B. EXPENDITURES AND OTHER FINANCING USES						
1. Certificated Salaries						
a. Base Salaries				13,933,867.00		14,296,867.00
b. Step & Column Adjustment				328,000.00		328,000.00
c. Cost-of-Living Adjustment						
d. Other Adjustments				35,000.00		35,000.00
e. Total Certificated Salaries (Sum lines B1a thru B1d)	1000-1999	13,933,867.00	2.61%	14,296,867.00	2.54%	14,659,867.00
2. Classified Salaries						
a. Base Salaries				3,265,698.00		3,355,698.00
b. Step & Column Adjustment				90,000.00		90,000.00
c. Cost-of-Living Adjustment						
d. Other Adjustments						
e. Total Classified Salaries (Sum lines B2a thru B2d)	2000-2999	3,265,698.00	2.76%	3,355,698.00	2.68%	3,445,698.00
3. Employee Benefits	3000-3999	7,947,153.00	4.13%	8,275,153.00	4.17%	8,620,153.00
4. Books and Supplies	4000-4999	826,424.00	15.49%	954,424.00	21.79%	1,162,424.00
5. Services and Other Operating Expenditures	5000-5999	2,231,752.00	6.59%	2,378,752.00	9.25%	2,598,752.00
6. Capital Outlay	6000-6999	6,000.00	0.00%	6,000.00	0.00%	6,000.00
7. Other Outgo (excluding Transfers of Indirect Costs)	7100-7299, 7400-7499	21,525.00	0.00%	21,525.00	0.00%	21,525.00
8. Other Outgo - Transfers of Indirect Costs	7300-7399	(200,534.00)	0.00%	(200,534.00)	0.00%	(200,534.00)
9. Other Financing Uses						
a. Transfers Out	7600-7629	0.00	0.00%		0.00%	
b. Other Uses	7630-7699	0.00	0.00%		0.00%	
10. Other Adjustments (Explain in Section F below)						
11. Total (Sum lines B1 thru B10)		28,031,885.00	3.77%	29,087,885.00	4.21%	30,313,885.00

Description	Object Codes	2022-23 Budget (Form 01) (A)	% Change (Cols. C-A/A) (B)	2023-24 Projection (C)	% Change (Cols. E-C/C) (D)	2024-25 Projection (E)
C. NET INCREASE (DECREASE)						
IN FUND BALANCE (Line A6 minus line B11)		(601,567.00)		(95,630.00)		(162,630.00)
D. FUND BALANCE						
1, Net Beginning Fund Balance (Form 01, line F1e)		10,295,886.00		9,694,319.00		9,598,689.00
2, Ending Fund Balance (Sum lines C and D1)		9,694,319.00		9,598,689.00		9,436,059.00
3, Components of Ending Fund Balance						
a. Nonspendable	9710-9719	10,000.00		10,000.00		10,000.00
b. Restricted	9740					
c. Committed						
1. Stabilization Arrangements	9750	0.00				
2. Other Commitments	9760	0.00				
d. Assigned	9780	0.00				
e. Unassigned/Unappropriated						
1. Reserve for Economic Uncertainties	9789	0.00				
2. Unassigned/Unappropriated	9790	9,684,319.00		9,588,689.00		9,426,059.00
f. Total Components of Ending Fund Balance (Line D3f must agree with line D2)		9,694,319.00		9,598,689.00		9,436,059.00
E. AVAILABLE RESERVES						
1. General Fund						
a. Stabilization Arrangements	9750	0.00		0.00		0.00
b. Reserve for Economic Uncertainties	9789	0.00		0.00		0.00
c. Unassigned/Unappropriated	9790	9,684,319.00		9,588,689.00		9,426,059.00
(Enter reserve projections for subsequent years 1 and 2 in Columns C and E; current year - Column A - is extracted.)						
2. Special Reserve Fund - Noncapital Outlay (Fund 17)						
a. Stabilization Arrangements	9750					
b. Reserve for Economic Uncertainties	9789					
c. Unassigned/Unappropriated	9790					
3. Total Available Reserves (Sum lines E1a thru E2c)		9,684,319.00		9,588,689.00		9,426,059.00
F. ASSUMPTIONS						
Please provide below or on a separate attachment, the assumptions used to determine the projections for the first and second subsequent fiscal years. Further, please include an explanation for any significant expenditure adjustments projected in lines B1d, B2d, and B10. For additional information, please refer to the Budget Assumptions section of the SACS Financial Reporting Software User Guide.						
B1d for both 23/24 and 24/25 shows the net cost of the addition of one dual language teacher (\$85k) and savings from 2 FTE retirements (-\$50k).						

Description	Object Codes	2022-23 Budget (Form 01) (A)	% Change (Cols. C-A/A) (B)	2023-24 Projection (C)	% Change (Cols. E-C/C) (D)	2024-25 Projection (E)
(Enter projections for subsequent years 1 and 2 in Columns C and E; current year - Column A - is extracted)						
A. REVENUES AND OTHER FINANCING SOURCES						
1. LCFF/Revenue Limit Sources	8010-8099	0.00	0.00%		0.00%	
2. Federal Revenues	8100-8299	2,373,272.00	0.00%	2,373,272.00	0.00%	2,373,272.00
3. Other State Revenues	8300-8599	366,978.00	0.00%	366,978.00	0.00%	366,978.00
4. Other Local Revenues	8600-8799	3,119,644.00	-6.09%	2,929,644.00	0.00%	2,929,644.00
5. Other Financing Sources						
a. Transfers In	8900-8929	0.00	0.00%		0.00%	
b. Other Sources	8930-8979	0.00	0.00%		0.00%	
c. Contributions	8980-8999	4,094,655.00	4.64%	4,284,655.00	0.00%	4,284,655.00
6. Total (Sum lines A1 thru A5c)		9,954,549.00	0.00%	9,954,549.00	0.00%	9,954,549.00
B. EXPENDITURES AND OTHER FINANCING USES						
1. Certificated Salaries						
a. Base Salaries				3,493,178.00		3,493,178.00
b. Step & Column Adjustment						
c. Cost-of-Living Adjustment						
d. Other Adjustments						
e. Total Certificated Salaries (Sum lines B1a thru B1d)	1000-1999	3,493,178.00	0.00%	3,493,178.00	0.00%	3,493,178.00
2. Classified Salaries						
a. Base Salaries				2,750,621.00		2,750,621.00
b. Step & Column Adjustment						
c. Cost-of-Living Adjustment						
d. Other Adjustments						
e. Total Classified Salaries (Sum lines B2a thru B2d)	2000-2999	2,750,621.00	0.00%	2,750,621.00	0.00%	2,750,621.00
3. Employee Benefits	3000-3999	2,694,569.00	0.00%	2,694,569.00	0.00%	2,694,569.00
4. Books and Supplies	4000-4999	864,806.00	-62.82%	321,563.00	0.00%	321,563.00
5. Services and Other Operating Expenditures	5000-5999	312,007.00	0.00%	312,007.00	0.00%	312,007.00
6. Capital Outlay	6000-6999	5,970.00	0.00%	5,970.00	0.00%	5,970.00
7. Other Outgo (excluding Transfers of Indirect Costs)	7100-7299, 7400-7499	327,627.00	0.00%	327,627.00	0.00%	327,627.00
8. Other Outgo - Transfers of Indirect Costs	7300-7399	49,014.00	0.00%	49,014.00	0.00%	49,014.00
9. Other Financing Uses						
a. Transfers Out	7600-7629	0.00	0.00%	0.00	0.00%	0.00
b. Other Uses	7630-7699	0.00	0.00%	0.00	0.00%	0.00
10. Other Adjustments (Explain in Section F below)						
11. Total (Sum lines B1 thru B10)		10,497,792.00	-5.17%	9,954,549.00	0.00%	9,954,549.00

Description	Object Codes	2022-23 Budget (Form 01) (A)	% Change (Cols. C-A/A) (B)	2023-24 Projection (C)	% Change (Cols. E-C/C) (D)	2024-25 Projection (E)
C. NET INCREASE (DECREASE) IN FUND BALANCE (Line A6 minus line B11)						
		(543,243.00)		0.00		0.00
D. FUND BALANCE						
1. Net Beginning Fund Balance (Form 01, line F1e)						
		1,755,019.00		1,211,776.00		1,211,776.00
2. Ending Fund Balance (Sum lines C and D1)						
		1,211,776.00		1,211,776.00		1,211,776.00
3. Components of Ending Fund Balance						
a. Nonspendable	9710-9719	0.00				
b. Restricted	9740	1,211,776.00		1,211,776.00		1,211,776.00
c. Committed						
1. Stabilization Arrangements	9750					
2. Other Commitments	9760					
d. Assigned	9780					
e. Unassigned/Unappropriated						
1. Reserve for Economic Uncertainties	9789					
2. Unassigned/Unappropriated	9790	0.00		0.00		0.00
f. Total Components of Ending Fund Balance (Line D3f must agree with line D2)		1,211,776.00		1,211,776.00		1,211,776.00
E. AVAILABLE RESERVES						
1. General Fund						
a. Stabilization Arrangements	9750					
b. Reserve for Economic Uncertainties	9789					
c. Unassigned/Unappropriated	9790					
(Enter reserve projections for subsequent years 1 and 2 in Columns C and E; current year - Column A - is extracted.)						
2. Special Reserve Fund - Noncapital Outlay (Fund 17)						
a. Stabilization Arrangements	9750					
b. Reserve for Economic Uncertainties	9789					
c. Unassigned/Unappropriated	9790					
3. Total Available Reserves (Sum lines E1a thru E2c)						
F. ASSUMPTIONS						
Please provide below or on a separate attachment, the assumptions used to determine the projections for the first and second subsequent fiscal years. Further, please include an explanation for any significant expenditure adjustments projected in lines B1d, B2d, and B10. For additional information, please refer to the Budget Assumptions section of the SACS Financial Reporting Software User Guide.						



Kurt Hauffe
714 925 7878
kurt@hauffecompany.com
2713 Lowell Lane
Santa Ana, California 92706
CSLB Number
612305,A,B,C10,C16,C20,C36,C54
DSA Class 1 #5488

June 15, 2022,

Andrea Reynolds
Assistant Superintendent of Administrative Services
Lowell Joint School District
11019 Valley Home Avenue
Whittier, CA 90603

Re: Fee Proposal for measure LL.

Dear Ms. Reynolds,

We are pleased to provide the following proposal to furnish special services for facilities program management and in support of bond measure LL.

The consulting fee will not exceed \$125,000 (one hundred twenty-five thousand dollars) for the term of June 1, 2022, to June 30, 2023. The billing will be applied on level of four completion progress payments based on the following schedule.

1. 30%-July 1, 2022 to September 30, 2022 in the amount of \$37,500
2. 30%- October 1, 2022 to December 30, 2022 in the amount of \$37,500
3. 30%- January 1, 2023 to March 30, 2023 in the amount of \$37,500
4. 10%- April 1, 2023 to June 30, 2023 in the amount of \$12,500

I hope this meets your needs and look forward to continuing our successful business relationship with the district.

Sincerely,

Kurt Hauffe
President Hauffe Company Inc.



Lowell Joint School District

A Tradition of Excellence Since 1906

LCFF Budget Overview for Parents

Local Educational Agency (LEA) Name: Lowell Joint School District

CDS Code: 30-64766-0000000

School Year: 2022-23

LEA contact information:

Jim Coombs

Superintendent

jcoombs@ljsd.org

562.902.4203

School districts receive funding from different sources: state funds under the Local Control Funding Formula (LCFF), other state funds, local funds, and federal funds. LCFF funds include a base level of funding for all LEAs and extra funding - called "supplemental and concentration" grants - to LEAs based on the enrollment of high needs students (foster youth, English learners, and low-income students).

Budget Overview for the 2022-23 School Year

Projected Revenue by Fund Source

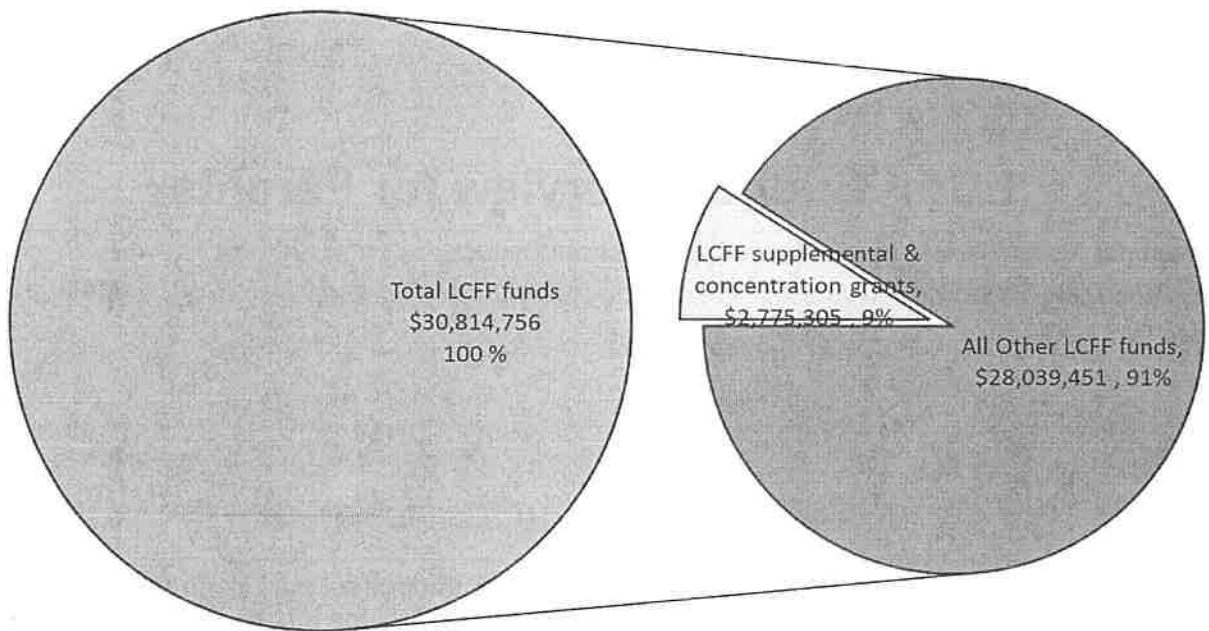

This chart shows the total general purpose revenue Lowell Joint School District expects to receive in the coming year from all sources.

The text description for the above chart is as follows: The total revenue projected for Lowell Joint School District is \$30,814,756, of which \$30,814,756 is Local Control Funding Formula (LCFF), \$ is other state funds, \$ is local funds, and \$ is federal funds. Of the \$30,814,756 in LCFF Funds, \$2775305 is generated based on the enrollment of high needs students (foster youth, English learner, and low-income students).

LCFF Budget Overview for Parents

The LCFF gives school districts more flexibility in deciding how to use state funds. In exchange, school districts must work with parents, educators, students, and the community to develop a Local Control and Accountability Plan (LCAP) that shows how they will use these funds to serve students.

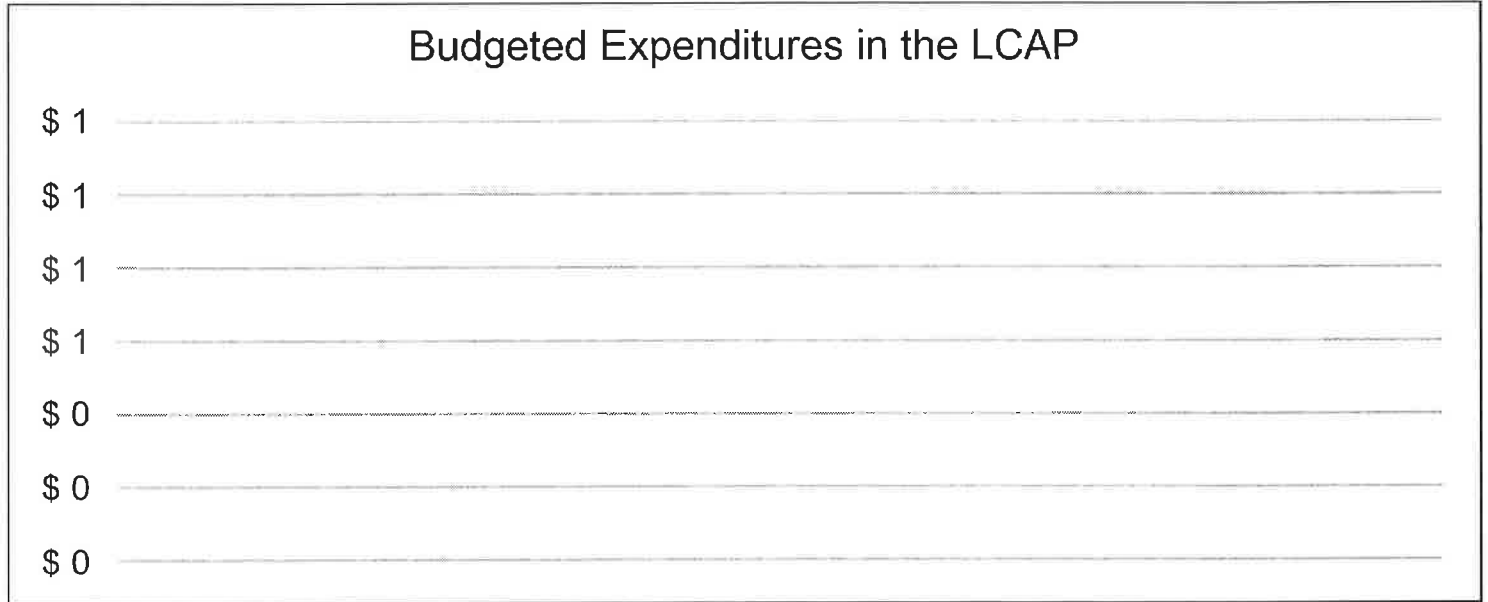

This chart provides a quick summary of how much Lowell Joint School District plans to spend for 2022-23. It shows how much of the total is tied to planned actions and services in the LCAP.

The text description of the above chart is as follows: Lowell Joint School District plans to spend \$ for the 2022-23 school year. Of that amount, \$ is tied to actions/services in the LCAP and \$0 is not included in the LCAP. The budgeted expenditures that are not included in the LCAP will be used for the following:

Increased or Improved Services for High Needs Students in the LCAP for the 2022-23 School Year

In 2022-23, Lowell Joint School District is projecting it will receive \$2775305 based on the enrollment of foster youth, English learner, and low-income students. Lowell Joint School District must describe how it intends to increase or improve services for high needs students in the LCAP. Lowell Joint School District plans to spend \$ towards meeting this requirement, as described in the LCAP.

LCFF Budget Overview for Parents

Update on Increased or Improved Services for High Needs Students in 2021-22

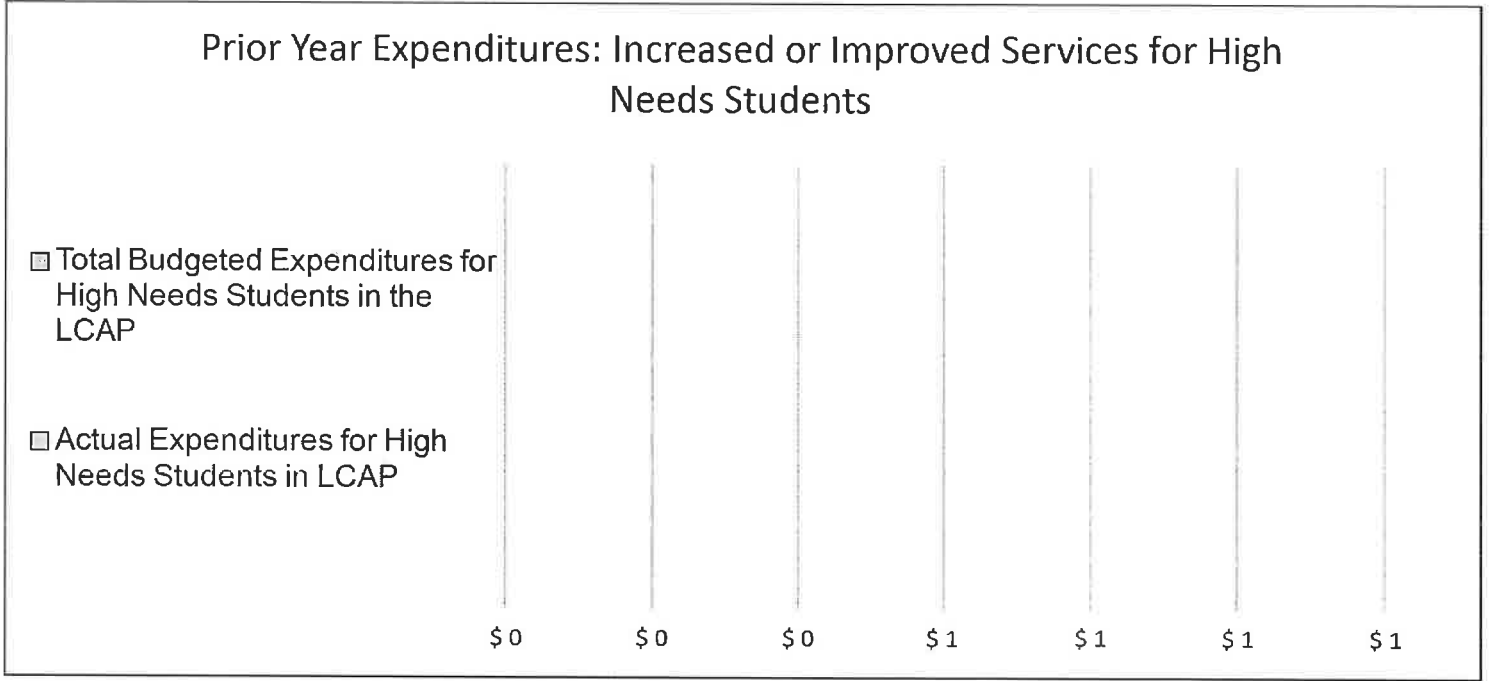

This chart compares what Lowell Joint School District budgeted last year in the LCAP for actions and services that contribute to increasing or improving services for high needs students with what Lowell Joint School District estimates it has spent on actions and services that contribute to increasing or improving services for high needs students in the current year.

The text description of the above chart is as follows: In 2021-22, Lowell Joint School District's LCAP budgeted \$ for planned actions to increase or improve services for high needs students. Lowell Joint School District actually spent \$ for actions to increase or improve services for high needs students in 2021-22.



A Tradition of Excellence Since 1906

Supplement to the Annual Update to the 2021–22 Local Control and Accountability Plan

Local Educational Agency (LEA) Name	Contact Name and Title	Email and Phone
Lowell Joint School District	Jim Coombs Superintendent	jcoombs@ljsd.org 562.902.4200

California’s 2021–22 Budget Act, the federal American Rescue Plan Act of 2021, and other state and federal relief acts have provided local educational agencies (LEAs) with a significant increase in funding to support students, teachers, staff, and their communities in recovering from the COVID-19 pandemic and to address the impacts of distance learning on students. The following is a one-time mid-year report to the local governing board or body and educational partners related to engagement on, and implementation of, these Acts.

A description of how and when the LEA engaged, or plans to engage, its educational partners on the use of funds provided through the Budget Act of 2021 that were not included in the 2020–21 Local Control and Accountability Plan (LCAP).

Because of the short timeline involved in developing plans along side the current planning for the Local Control Accountability Plan (LCAP), discussions related to the additional monies (Educator Effectiveness, Expanded Learning Opportunity Program, and the Universal Pre-Kindergarten) were held during the already scheduled meetings with educational partners for LCAP input. It was discussed separately from the LCAP process as an opportunity to include one-time dollars in services we would be able to provide for students that fit within the categories identified for appropriate expenditures. With that in mind, educational partners were given the opportunity to provide input both during the meeting and as part of a Padlet created to capture the thoughts of various educational partners for both the LCAP and these new one-time funds. The Assistant Superintendent of Educational Services is meeting with the Parent Teacher Associations (PTAs) for each school site, with the staff at each school site, the District English Learner Advisory Committee (DELAC), the LCAP Advisory Committee, California School Employees Association (CSEA) for classified staff, and Lowell Joint Education Association (LJEA) for certificated staff. In addition, communications through the Superintendent’s Office in the Healthy Families Update for both staff and parents provided information on potential opportunities for input at meetings as well as regularly scheduled meetings with PTAs. The surveys conducted for the LCAP also provide information from parents, staff, and students that have helped to inform services that we may provide under the Extended Learning Opportunities Grant/Program even though the survey was specific to the LCAP process. Discussions specific to the development of all plans

were also part of both Instructional Cabinet meetings and Principal meetings. The Board of Trustees is updated on a weekly basis through the Superintendent's Office in addition to information shared at regularly scheduled Board meetings once a month.

A description of how the LEA used, or plans to use, the additional concentration grant add-on funding it received to increase the number of staff who provide direct services to students on school campuses with an enrollment of students who are low-income, English learners, and/or foster youth that is greater than 55 percent.

As a district, Lowell Joint does not receive any concentration monies and was therefore, not eligible for these additional funds.

A description of how and when the LEA engaged its educational partners on the use of one-time federal funds received that are intended to support recovery from the COVID-19 pandemic and the impacts of distance learning on pupils.

Again, due to the short timeline involved in developing plans along side the current planning for the Local Control Accountability Plan (LCAP), discussions related to the development of the Extended Learning Opportunities Grant Plan (ELO-G), the Learning Continuity Plan, and the Safe Return to Instruction plan were held during the already scheduled meetings with educational partners for LCAP input. It was discussed separately from the LCAP process as an opportunity to include one-time dollars in services we would be able to provide for students over the next two years that fit within the categories identified for appropriate expenditures. With that in mind, educational partners were given the opportunity to provide input both during the meeting and as part of a Padlet created to capture the thoughts of various educational partners for both the LCAP and these new on-time and ongoing funds. The Assistant Superintendent of Educational Services is meeting with the Parent Teacher Associations (PTAs) for each school site, with the staff at each school site, the District English Learner Advisory Committee (DELAC), the LCAP Advisory Committee, California School Employees Association (CSEA) for classified staff, and Lowell Joint Education Association (LJEA) for certificated staff. In addition, communications through the Superintendent's Office in the Healthy Families Update for both staff and parents provided information on potential opportunities for input at meetings as well as regularly scheduled meetings with PTAs. The surveys conducted for the LCAP also provide information from parents, staff, and students that have helped to inform services that we may provide under the Extended Learning Opportunities Grant/Program even though the survey was specific to the LCAP process. Discussions specific to the development of all plans were also part of both Instructional Cabinet meetings and Principal meetings. The Board of Trustees is updated on a weekly basis through the Superintendent's Office in addition to information shared at regularly scheduled Board meetings once a month.

A description of how the LEA is implementing the federal American Rescue Plan Act and federal Elementary and Secondary School Emergency Relief expenditure plan, and the successes and challenges experienced during implementation.

The Elementary and Secondary School Emergency Relief Plan (ESSER III) is being monitored for implementation in terms of identified actions and expenditures on a regular basis. A coding system was implemented within the Purchase Request system to identify and track various expenditures back to the appropriate plan, goal, and action item whether it is one-time dollars or within the LCAP itself with ongoing funds. Within the seven categories for expenditure, as an example, summer school and intersession is one action item. Of the \$550,000 identified for this item, \$260,000 was expended in the first summer with the rest available for the summer of 2022. All expenses were coded back to this particular item to facilitate the monitoring and reporting of the items within the plan. This has been a tremendous success in tracking the expenditures. The greatest challenge has been the overlap in criteria for the various funding sources. This often requires the movement of expenditures to funding that must be expended on a shorter timeline that meets the same criteria. Another serious challenge has been in finding staffing to expend some of the funds that were targeted for before and after school programs as well as other positions to support programs within the day. We have been able to ensure continuity of services through developing a Virtual Academy for long-term Independent Study, academic support for those students in short-term Independent Study, increasing sub pay to cover teacher absences due to Covid-related quarantine and isolation to be competitive with neighboring districts in the sub shortage, providing PPE for staff and students, providing regular testing as well as at-home testing kits to facilitate safe school environments, and having access to an additional school nurse to support the increased demands related to health and safety within the district.

A description of how the LEA is using its fiscal resources received for the 2021–22 school year in a manner that is consistent with the applicable plans and is aligned with the LEA’s 2021–22 LCAP and Annual Update.

For each of the required plans for both one-time dollars and on-going funding in addition to the LCAP, a coding system has been developed in fiscal to identify the plans connection where appropriate to the goals and actions within the LCAP. This allows for the tracking of expenditures related to the individual plan as well as the connection to related expenditures within the LCAP to ensure alignment. These are reviewed on a regular basis by the Assistant Superintendent of Educational Services and the Director of Fiscal Services as Purchase Requests are submitted for various funding sources and plan items.

Instructions for the Supplement to the Annual Update for the 2021–22 Local Control and Accountability Plan Year

For additional questions or technical assistance related to the completion of the Supplement to the Annual Update to the 2021–22 Local Control and Accountability Plan (LCAP), please contact the local county office of education (COE), or the California Department of Education’s (CDE’s) Local Agency Systems Support Office, by phone at 916-319-0809 or by email at lcff@cde.ca.gov.

Introduction

California's 2021–22 Budget Act, the federal American Rescue Plan Act of 2021, and other state and federal relief acts have provided local educational agencies (LEAs) with a significant increase in funding to support students, teachers, staff, and their communities in recovering from the COVID-19 pandemic and to address the impacts of distance learning on students. Section 124(e) of Assembly Bill 130 requires LEAs to present an update on the Annual Update to the 2021–22 LCAP and Budget Overview for Parents on or before February 28, 2022, at a regularly scheduled meeting of the governing board or body of the LEA. At this meeting, the LEA must include all of the following:

- The Supplement to the Annual Update for the 2021–22 LCAP (2021–22 Supplement);
- All available mid-year outcome data related to metrics identified in the 2021–22 LCAP; and
- Mid-year expenditure and implementation data on all actions identified in the 2021–22 LCAP.

When reporting available mid-year outcome, expenditure, and implementation data, LEAs have flexibility to provide this information as best suits the local context, provided that it is succinct and contains a level of detail that is meaningful and accessible for the LEA's educational partners.

The 2021–22 Supplement is considered part of the 2022–23 LCAP for the purposes of adoption, review, and approval, and must be included with the LCAP as follows:

- The 2022–23 Budget Overview for Parents
- The 2021–22 Supplement
- The 2022–23 LCAP
- The Action Tables for the 2022–23 LCAP
- The Instructions for the LCAP Template

As such, the 2021–22 Supplement will be submitted for review and approval as part of the LEA's 2022–23 LCAP.

Instructions

Respond to the following prompts, as required. In responding to these prompts, LEAs must, to the greatest extent practicable, provide succinct responses that contain a level of detail that will be meaningful and accessible for the LEA's educational partners and the broader public and must, to the greatest extent practicable, use language that is understandable and accessible to parents.

In responding to these prompts, the LEA has flexibility to reference information provided in other planning documents. An LEA that chooses to reference information provided in other planning documents must identify the plan(s) being referenced, where the plan(s) are located (such as a link to a web page), and where in the plan the information being referenced may be found.

Prompt 1: "A description of how and when the LEA engaged, or plans to engage, its educational partners on the use of funds provided through the Budget Act of 2021 that were not included in the 2020–21 Local Control and Accountability Plan (LCAP)."

In general, LEAs have flexibility in deciding what funds are included in the LCAP and to what extent those funds are included. If the LEA received funding through the Budget Act of 2021 that it would have typically included within its LCAP, identify the funds provided in the Budget Act of 2021 that were not included in the LCAP and provide a description of how the LEA has engaged its educational partners on the use of funds. If an LEA included the applicable funds in its adopted 2021–22 LCAP, provide this explanation.

Prompt 2: “A description of how LEA used, or plans to use, the concentration grant add-on funding it received to increase the number of staff who provide direct services to students on school campuses with an enrollment of students who are low-income, English learners, and/or foster youth that is greater than 55 percent.”

If LEA does not receive a concentration grant or the concentration grant add-on, provide this explanation.

Describe how the LEA is using, or plans to use, the concentration grant add-on funds received consistent with California Education Code Section 42238.02, as amended, to increase the number of certificated staff, classified staff, or both, including custodial staff, who provide direct services to students on school campuses with greater than 55 percent unduplicated pupil enrollment, as compared to schools with an enrollment of unduplicated students that is equal to or less than 55 percent.

In the event that the additional concentration grant add-on is not sufficient to increase the number of staff providing direct services to students at a school with an enrollment of unduplicated students that is greater than 55 percent, describe how the LEA is using the funds to retain staff providing direct services to students at a school with an enrollment of unduplicated students that is greater than 55 percent.

Prompt 3: “A description of how and when the LEA engaged its educational partners on the use of one-time federal funds received that are intended to support recovery from the COVID-19 pandemic and the impacts of distance learning on pupils.”

If the LEA did not receive one-time federal funding to support recovery from the COVID-19 pandemic and the impacts of distance learning on students, provide this explanation.

Describe how and when the LEA engaged its educational partners on the use of one-time federal funds it received that are intended to support recovery from the COVID-19 pandemic and the impacts of distance learning on students. See the COVID-19 Relief Funding Summary Sheet web page (<https://www.cde.ca.gov/fg/cr/relieffunds.asp>) for a listing of COVID-19 relief funding and the Federal Stimulus Funding web page (<https://www.cde.ca.gov/fg/cr/>) for additional information on these funds. The LEA is not required to describe engagement that has taken place related to state funds.

Prompt 4: “A description of how the LEA is implementing the federal American Rescue Plan Act and federal Elementary and Secondary School Emergency Relief expenditure plan, and the successes and challenges experienced during implementation.”

If an LEA does not receive ESSER III funding, provide this explanation.

Describe the LEA’s implementation of its efforts to maintain the health and safety of students, educators, and other staff and ensure the

continuity of services, as required by the federal American Rescue Plan Act of 2021, and its implementation of the federal Elementary and Secondary School Emergency Relief (ESSER) expenditure plan to date, including successes and challenges.

Prompt 5: “A description of how the LEA is using its fiscal resources received for the 2021–22 school year in a manner that is consistent with the applicable plans and is aligned with the LEA’s 2021–22 LCAP and Annual Update.”⁷

Summarize how the LEA is using its fiscal resources received for the 2021–22 school year to implement the requirements of applicable plans in a manner that is aligned with the LEA’s 2021–22 LCAP. For purposes of responding to this prompt, “applicable plans” include the Safe Return to In-Person Instruction and Continuity of Services Plan and the ESSER III Expenditure Plan.

California Department of Education
November 2021



A Tradition of Excellence Since 1906

Local Control Accountability Plan

The instructions for completing the Local Control and Accountability Plan (LCAP) follow the template.

Local Educational Agency (LEA) Name	Contact Name and Title	Email and Phone
Lowell Joint School District	Jim Coombs Superintendent	jcoombs@ljsd.org 562.902.4203

Plan Summary [2022-23]

General Information

A description of the LEA, its schools, and its students in grades transitional kindergarten–12, as applicable to the LEA.

The Lowell Joint School District was established in 1906 and encompasses 8 square miles in the cities of La Habra, La Habra Heights, Whittier, and portions of unincorporated Los Angeles County. The District serves the educational needs of approximately 3,050 students in Transitional Kindergarten through eighth grade at five TK-6 elementary schools and one intermediate school. There is also a special needs preschool at one elementary site. The race/ethnic break down of the student population includes significant student groups for Hispanic at 69.2% and White, non-Hispanic at 19.4%. There are also 4.5% Asian, 1.6% Filipino, and 1.4% African American with a few students in other ethnicities. Within the overall student population, approximately 12% qualify for Special Ed services, 8% for English Learners, 1% McKinney Vento (a 5% decrease), with 53% low income. This is a significant increase in families qualifying for free/reduced lunch from the prior year at 41%. While we do not have a significant number of Foster Youth (less than 1%), we monitor all of these student groups to provide targeted support based on need in our overall Multi-Tiered System of Supports or MTSS. All six schools have received a Pivotal Practice Award in the 2021-22 school year as well as recognition as California Distinguished Schools and Gold Ribbon schools in prior years. Rancho Starbuck Intermediate was also designated as a School To Watch in the 2016-17 school year and was redesignated in the 2020 school year. All Title I schools were honored with the Title I Academic Achievement Award in 2015-16 as well as the Business Excellence Award. The District is committed to providing strong academics, basic skills, and a well-rounded program of traditional subject offerings. We emphasize the importance of education, the family, and traditional American values: higher education, personal integrity, social responsibility, Character

Education, and an appreciation of our national heritage are all stressed at District schools. All students have access to Chromebooks as part of our 1:1 Chromebook Initiative along with professional development for teachers in instructional practices for technology integration. All students have access to technology through STEAM activities either within the classroom or in the STEAM Lab including 3D printers, Virtual Reality, Strawbees, Spheros, Green Screen set-ups, and Ozobots. Both Rancho Starbuck and El Portal have been honored with Golden Bell Awards, and El Portal has been selected as a No Excuses University site (2019). The district has been honored with the two very prestigious Magna awards from the National School Boards Association on a national level for it's Blue Ribbon Special Education team and Arts for All: Let the Music Play (2022-Grand Prize winner).

With the support of our community, Lowell Joint was able to pass a bond measure (Measure LL) in 2019 that is allowing the district to tackle some much needed improvements to the aging facilities since most schools were built in the 1950s and 60s. Work has already been completed at Olita, El Portal, and Macy with Jordan finishing up in June of 2022. The scope of work includes roofing, HVAC systems, associated electrical, sewer lines, replacement of wood affected by termites and/or wood rot, and various other projects related to bringing our schools into the 21st century. Meadow Green will undergo updates in the 2022-2023 school year. Additional district funds have been able to add to the scope of work including painting, marquees, and water-bottle filling stations as examples.

On October 2, 2017, the Board of Trustees approved the Guiding Goals and accompanying descriptions which serve as the overarching vision for the Lowell Joint School District. These are affirmed each year by the Board. The Mission and Board Goals are listed below:

Mission: The Lowell Joint School District is committed to providing a strong academic program of 21st Century Skills with a well-rounded program of diverse and innovative subject offerings. All District Schools emphasize the importance of education, the family, and traditional values. We stress the value of personal; integrity, social responsibility, and a respect for our national heritage. The Lowell Joint School District envisions a culture where technology empowers all members of the school community to achieve success and expand learning beyond the walls of the classroom. All stakeholders will utilize technology to become highly competent in a technological world through continuous improvement in academics, career, and life.

Guiding Goals

DISTRICT GOAL 1: ACADEMIC EXCELLENCE - LEARNING FOR ALL STUDENTS

Vision: Every student experiences educational success at the highest levels of achievement. We believe that each student has a unique ability to learn in an environment that is enriched with a challenging curriculum, where learning is modeled and expectations are both known and high. We expect all students to demonstrate continued and improved academic achievement, through Collaboration, Communication, Critical thinking, and Creativity, to be college and career ready, and to become lifelong learners.

DISTRICT GOAL 2: SAFE, ORDERLY, POSITIVE, RESPECTFUL LEARNING ENVIRONMENTS

Vision: All campuses provide an aesthetic, orderly environment that is organized to ensure learning. We believe in a collaborative spirit of place where all feel safe, welcomed, valued, and respected. We foster a culture that promotes the emotional health, safety, well-being and involvement of students, staff, family and community.

DISTRICT GOAL 3: HIGH QUALITY STAFF PROVIDING HIGH QUALITY SERVICE

Vision: All staff possesses the appropriate knowledge, skills, and attitudes needed to provide high quality services leading to high quality results. We believe that high quality service is achieved when staff is well trained, proactive, responsive, and collaborative. We attract, train, and retain high performing staff that actively engage, collaborate, and support students in effective instruction and the use of current technologies.

DISTRICT GOAL 4: SCHOOL/ FAMILY/ COMMUNITY PARTNERSHIPS & COMMUNICATION

Vision: High quality student learning is supported by partnerships. We believe these partnerships are enhanced through effective communication and collaboration. We establish a culture which encourages positive relationships among our students, staff, and families as well as educational, business, and community partners. We believe these partnerships and communication must be nurtured to optimize opportunities for learning and personal growth for students.

DISTRICT GOAL 5: ACQUISITION & ALLOCATION OF RESOURCES TO SUPPORT FISCAL EXCELLENCE

Vision: Resources are focused to achieve district goals. We believe that public schools deserve sufficient resources to achieve high quality student learning. We believe that efficiency, transparency, and cost-effective practices must characterize District and school operations to ensure that resources are aligned and applied to achieve established goals. We are committed to remaining fiscally solvent by effectively managing resources and pursuing new revenue sources.

Reflections: Successes

A description of successes and/or progress based on a review of the California School Dashboard (Dashboard) and local data.

Given the disruption in the 2019-2020 and 2020-2021 school years due to the pandemic, many of our goals and action items remained in place for 2021-2022 until we had better data to monitor progress using the same metrics. Comparatively speaking, we had relatively high attendance with a district average of approximately 96% during distance learning in 2020-2021. For the 2021-2022 school year, we did not anticipate the extreme number of students who would be out due to quarantine and isolation requiring a significant increase in the number of students with absence issues at the beginning of the year before the state made adjustments to coding for independent study due to quarantine/isolation. Our average attendance for the 2021-2022 school year as of May 2022 is 94.2% with a range from 91.84% to 95.76% between the six sites. We have been actively monitoring our chronic absentee rates for the last six years internally. In the 2018-19 school year Lowell Joint had a chronic absentee rate of 4.8% in comparison to the State at 9%. Attendance data was skewed with the closures in March of 2020 and distance/hybrid learning for the 2020-2021 school year. Dataquest reports our Chronic Absentee percentage at 4.9% for 2020-2021 which is well below the state at 14.3% and LA County at 12.9%. With the number of students in quarantine and isolation during the 2021-2022 school year, we will still need to focus on this area given the drop in attendance. However, during an extremely difficult season, we have managed to keep kids in engaged and attending school at a fairly consistent level to pre-pandemic which is a success. And within that data, there is less than a 2% difference between our largest student group populations of Hispanic/Latino; African American, and White.

While Lowell Joint continues to be a high performing district, there has definitely been a need to address students who have not been successful in the traditional program. The district has worked closely with each of the sites to determine the areas of greatest need and how to address those needs. Rancho Starbuck has an award-winning intervention program that provides additional support for students struggling with reading, mathematics, or language development. Two sections each of reading and math intervention, and an ELD support class provide targeted assistance to students needing a little extra help to be successful academically. Additional STEAM offerings provide enrichment and engagement for students including a pathway that leads to AP Computer Science. Rancho Starbuck was honored as a School to Watch in 2016 initially and for their ongoing efforts in creating an engaging environment for learning that supports all students in high levels of achievement. For all sites, providing intervention opportunities within the school day has been an ongoing focus. Refining our Multi-tiered System of Support (MTSS) to meet the needs of all students and close performance gaps is an ongoing process based on changes in data each year. While the data is somewhat skewed from the spring of 2021, we were still above state and Los Angeles county proficiency levels with 52% meeting or exceeding in English language arts and 35% in mathematics compared to 49% for the state in ELA and 34% for mathematics. LA county was at 48% for ELA and 31% for mathematics. For both areas, we were below the Orange county levels of proficiency at 61% and 43%. This is not entirely surprising given the extended period of time students were in distance learning and the lower rate of participation overall. We implemented iReady this year for the first time, so we are relying heavily on that data to support some of the gaps in state assessment data. The placements in the program for English language arts show a 12% increase in the number of students in the "mid on-grade or above" category with another 3% increase in "early on-grade" This gives us a total of 51% in these two levels compared to the beginning of the year with only 36%. For our 7th and 8th grade students, the median percent of typical growth was 133% and 139% respectively. Some of the greatest growth areas are for students in the primary grades that will not show up in state assessments. Kindergarten moved from 31% on grade level to 65% between fall and winter for example. We are currently administering the 3rd assessment for the spring, so we hope to have that comparison data shortly to see the full growth for the year and compare that with state assessment scores when they are released for 2022. This is a tremendous success, however, given the difficulties of the year with the number of students out for quarantine/isolation. The results are similar in mathematics with an 11% increase in fall to winter placement in "mid on-grade or above" for an overall jump from 18% to 38% in the two on-grade level categories. These winter assessment results are from late January so we would anticipate similar growth for the spring assessments.

The Special Education Blue Ribbon Action Team was formed to completely revamp Board policies and procedures to better serve our students with disabilities. This committee included teachers, district personnel, SELPA representation, a lawyer from OCDE, and a professor from Biola in order to ensure that best practices and education code were all forefront in discussions. All policies and procedures were reviewed, revised, and submitted for Board approval. As a result of all this work, the district was honored with the very prestigious Magna award from the National School Boards Association in 2021 and a subsequent Golden Bell award in 2022. Members of this committee presented at the ACSA Region 17 Administrator Conference and are sharing at a staff meeting for each of the six sites during the 2021-2022 school year to develop a better understanding of these policies and procedures for all staff. On the heels of this award, the district received a Golden Bell award and a second Magna award in 2022 for the arts program Arts for All: Let the Music Play. In the category for small schools, Lowell Joint was actually the grand prize winner for 2022. Each of the six schools received a Pivotal Practice award from the state in 2022 as well which highlights effective strategies for supporting students during the 2020-21 school year when California required schools to offer distance learning due to the COVID-19 pandemic. These are just a few examples of the recognition received through outside agencies that helps to validate the incredibly dedicated staff in Lowell Joint who strive to make things better in service of our students.

We hired 10 paid interns for the 2021-2022 school year (4 counseling and 6 psych) to work directly with current personnel to increase services through our C.R.E.W. (Creative Response to Emotional and Educational Wellness) program. This was the fourth year of this program, which continues to be a success. These services are in addition to the existing partnership with the Gary Center (no cost), a partnership with Supervisor Hahn's Office for limited counseling support (no cost), an existing counselor and existing Psych services. The response to C.R.E.W. has been overwhelmingly positive on all school campuses. The vast majority of counseling done through the interns has been personal/social counseling with over 600 meetings for counseling services in this area. The next largest counseling type has been academic counseling and "other" with over 200 meetings each. As we know, those two issues go hand-in-hand. If a student is struggling personally, there is a good change there are academic issues as well and if there are academic issues, there are usually personal struggles present. Staff continue to appreciate that there are more hands on deck to help students in all areas from academic to personal/social needs. It has been helpful to provide more personalized supports for students. For example, when an SST is held for a student, it is now feasible to offer weekly check-ins with a counseling/psychologist intern as a way to support student progress. The interns have done presentations in classes on topics such as "how to be a good friend" and career interest inventories. They have held group sessions for students struggling with grief or for students who struggle to complete homework. They work with students that have trouble controlling their anger, which can play out in aggression in the classroom or with their peers. They work with students suffering from anxiety and overwhelming emotional issues, which has been especially helpful during the pandemic. The interns have helped with supervision, a key role in the job of a school counselor, as well as helped with FLEX classes when students were on campus. The counseling interns have also sat in on SST's and IEPS and helped with the College Planning Night for parents at Rancho. Teachers and staff have appreciated the support as we continue to meet the needs of students, and students are continuing to benefit from the support and encouragement that the interns provide. Overall, the implementation of C.R.E.W. is a continued success and will only continue to grow. We did lose three of the counseling interns over the course of the year, so we will look at ways to help create sustainability in those positions for next year. The addition of Care Solace as a 3rd-party vendor to support families in navigating mental health supports has also been a success.

The community passed Measure LL in November of 2018 with overwhelming support for our Lowell Joint schools. The bond has allowed for the upgrade and modernization of facilities that were constructed in the 1950s and 60s. With the school closures during the pandemic, the work was started earlier than expected with no students on campus and accelerated without having to manage temporary housing. This allowed for completion of construction in a more timely manner, which moved up the timelines. This continues to save on construction costs and the repayment schedule. Olita, El Portal, Macy, and Jordan are completed with Meadow Green slated for the 22-23 school year. That leaves only Rancho Starbuck to complete the scope of the work identified in the Measure LL bond.

As a district, the focus on early learning with the Grant from First Five OC has allowed us to offer a Learning Link this year. The Learning Link is a space for parents to come with their child age 0-5 and engage in activities to build school readiness in areas such as gross and fine motor skills, cooperation with other kids, following routines, letters and sounds, and so forth. It allows for support of parents in activities they can do at home as well to continue to develop a strong foundation for learning. It opened in January with just two days a week to begin serving approximately 24 families. The response was so overwhelmingly positive that we added a third day almost immediately. Fun, Physical Fridays were added in March and split into two sessions to accommodate the growing demand. We are currently servicing over 40 families who have connected with each other to create a community. The parents are volunteering to help set up and take down on Fridays and have asked us to continue the Learning Link through the summer. We are exploring the possibilities for this summer, but we can definitely plan for that in the future. We have also applied for a state funded preschool again since the process was interrupted in 2020 due

to the pandemic. We are looking to open both full day and part day options on a small scale as we increase our services for early learners and plan for the expanded learning opportunities required by the state. We have hired Coordinators for both Early Learning and Expanded Learning to support the growth of programs in these two areas, which is very exciting. Lowell Joint doesn't qualify for after school funding from the state (ASES), so this new funding under the Expanded Learning Opportunities-Program (ELO-P) will allow us to service students needing academic supports as well as enrichment while supporting families who are in need of additional hours of child care. We have applied for two preschool licenses to accommodate the growing number of families in need of affordable preschool. We have received our fundable score letter from the California Department of Education on our preschool application and are awaiting the final notification that we have been awarded a contract from the state for a state-funded preschool. We will be able to offer both a part-day and full-day option for the 2022-23 school year, which is very exciting for our district.

Reflections: Identified Need

A description of any areas that need significant improvement based on a review of Dashboard and local data, including any areas of low performance and significant performance gaps among student groups on Dashboard indicators, and any steps taken to address those areas.

Refining our Multi-tiered System of Support (MTSS) to meet the behavior and social-emotional needs of all students continues to be a priority. Echoed in feedback from all stakeholder groups, there is a serious concern for the social-emotional well-being of students, staff, and families in returning to campus after another year of disruption, loss, and trauma on varying levels for everyone. We had already begun to develop some supports in this area, with the introduction of C.R.E.W. prior to the pandemic as described above. There is still a need to increase the focus on social emotional learning in the classroom on a daily basis given the past year. Data from Covitality, a universal social-emotional screener for grades 4-8, was used to identify students at risk that could be supported by interns and other school personnel. The limited scope of Covitality is being augmented by adding Care Solace as a partner. Care Solace developed a website for our district to connect students, families, and staff to mental health supports in the area, help them navigate issues such as insurance and referrals, and check in to determine if the services are meeting the need. Individuals can use the site themselves or district personnel can refer individuals to the site for support. While this information went out through a Healthy Family Newsletter and families are being referred through staff, the links to the website are not readily accessible from the district website or the individual school websites, which needs to be addressed. This will support the self-referral process. The counselor and interns again provided lessons on social emotional issues throughout the 2021-2022 school year. We purchased the Social Emotional Learning (SEL) curriculum from Studies Weekly for students in grades TK-6 last year to support classrooms along with the Calm Classroom materials. There are varying levels of implementation, so we need to articulate baseline expectations and provide additional support where needed. Overall, social-emotional and other mental health needs continue to be an area for us to grow in.

Chronic absenteeism is still an area of concern. While we have no Dashboard data to determine improvements in the color bands, we do anticipate skewed data based on the number of students in isolation/quarantine throughout the 2021-22 school year. As we finish out the year, we will need to analyze different data sets to determine if we have made progress in this identified area from 2019-2020. This will remain an area of focus for us until we can determine more consistent data to see real growth. One of the strategies for increasing attendance is providing engaging opportunities for students to participate in that keep them connected to their classroom. Both parents and staff have expressed a desire for more art instruction for students, so we are partnering with the Muckenthaler Cultural Center to provide art

opportunities for all elementary sites this coming year. This will be in addition to the variety of before and after school offerings being developed as part of the Expanded Learning Opportunities program. A Youth Theater is also being developed based on student interest. These enrichment opportunities are a vital part of engaging students and creating a space students want to be a part of. Along side intervention for academic support, the goal is to connect students in ways that spark their creativity and passions.

Since not having Dashboard data for tracking Status and Change and the various color bands to show progress, there is still no direct comparison point for much of our Academic data. However, we are able to analyze the data from what CAASPP scores we have for 2021 in addition to the overall iReady data for the year mentioned above. Our overall percentage of students with Standard Met and Above for English Language Arts was at 52.27% with mathematics at 35.35%. Our most significant student group populations are Hispanic (69.2%) and White, non-Hispanic (19.4%). Following that as student groups are Asian (4.5%), Filipino (1.6%), and African American (1.4%) with a few remaining in other race and ethnicity groupings or 2 or more race and ethnicities. For Language Arts, the Hispanic student group was at 48.83%, White at 57.79%, Asian at 76.14%, Filipino at 71.43%, and African American at 32.14%. In comparison to all students, this puts our Hispanic and African American student groups behind. For mathematics, the Hispanic student group was at 30.98%, White at 40.2%, Asian at 72.73%, Filipino at 50%, and African American at 37.04%. In comparison to all students with Standard Met and Above at 35.35%, only the Hispanic student group is below that at 30.98%. Other student group data to be mindful of in the planning for our LCAP includes the academic data for our students with disabilities, English learners, and students on free/reduced lunch. Our Foster Youth population is small enough that the results are not reported, so we will pull those individual students for monitoring under MTSS. Our students with disabilities dropped significantly from our last CASSPP data with only 12.95% at Standard Met and Above in ELA compared to 57.05% for students with no reported disability and 10.35% for mathematics compared to 38.24%. For English learners, our Redesignated Fluent English Proficient students are at 55.95% for ELA which is above the English Only (EO) at 53.32%. This is exciting as it means our students exciting English learner status are maintaining at a rate consistent with non-English learners. For mathematics, the same was true with RFEF students at 42.06%, which is higher than EO at 35.37%. Our current English learners were struggling significantly with only 19.05% with Standard Met or Above for ELA and 14.02% for mathematics. Compared to the English Only numbers this is a 34.27% gap for English language arts and a 21.35% gap for math. Our economically disadvantaged student group (those on free/reduced lunch) were at 40.05% Standard Met or Above compared to 59.43% for those not economically disadvantaged. For mathematics the comparison is 24.77% to 41.38%. This represents about a 20% gap in both cases where historically our economically disadvantaged students have been extremely close to our non-economically disadvantaged. Clear areas of focus include support for our economically disadvantaged, English learners, Hispanic, and students with disabilities for both ELA and math. In addition to that, African American students need support in ELA. These identified gaps will help drive the services and resources provided under MTSS outlined primarily in Goal 4.

LCAP Highlights

A brief overview of the LCAP, including any key features that should be emphasized.

The LCAP has five identified goals to address both the eight State priorities and the five local Board goals. The first goal focuses on the basic conditions of learning necessary to ensure student success. The second goal highlights Early Literacy, which continues to be an area of growth for us. Over the last three years, we have been working toward adding a state-funded preschool and additional services to support school readiness for children ages 0-5 within our district boundaries. While the pandemic froze state funding for the preschool, we opened a

Learning Link that creates a space where parents can come with their child to engage in activities designed to support school readiness. We have applied for state funding for a preschool again and have developed a fee structure for a fee-based program. We have applied for two additional licenses to be able to open preschool sites at both Olita and Jordan. The current license at Maybrook was originally meant to support a preschool there while Jordan was under construction. The Universal Pre-Kindergarten (UPK) requirements from the state are also supporting movement around this goal. With some of our youngest learners in TK-2nd grade having the greatest issues with attendance and engagement during distance learning, there is a significant need to address gaps in skill development. Students have shown significant growth this year, and the additional resources and services we are planning for now under UPK will help support this. The third goal centers around the need to modernize facilities for the safety and well being of staff and students. The community passed Measure LL in November of 2018 with overwhelming support for our Lowell Joint schools. This bond is supporting the upgrade and modernization of facilities that were constructed in the 1950s and 60s. With the closing of the private school at the district's Maybrook site, that space is being used for housing students temporarily as we rotate sites through over the next few years. This has allowed for completion of construction in a more timely manner without having to work around students on campus, which is less disruptive for their educational experience. With the additional bond monies for identified upgrades to roofing, HVAC, and associated plumbing and electrical, district funds for maintenance will be available to expedite much needed repairs and/or upgrades to the sites outside of the scope of the bond. Olita, Macy, Jordan, and El Portal have already been completed with Meadow Green moving to the Maybrook site for the 2022-23 school year. Goal four includes the expansion of our Multi-Tiered System of Support (MTSS), which truly drives the overall vision of the district in meeting the Academic Excellence goal where "every student experiences educational success at the highest levels of achievement...[and] each student has a unique ability to learn in an environment that is enriched with challenging curriculum, where learning is modeled and expectations are both known and high". MTSS encompasses the academic, behavioral, and social emotional well being of each and every student as we strive to create an environment with supports and enrichment for all students to reach their full potential. The academic gaps noted in the Plan Summary: Reflections section will be addressed within our Multi-Tiered System of Support for students. The fifth goal is designed to focus on another continued area of growth for us in building enrichment opportunities and developing 21st century skills in our students. This again is a reflection of the mission of the district that "envisions a culture where technology empowers all members of the school community to achieve success and expand learning beyond the walls of the classroom". It has been another challenging year, but our staff and students have done well in adjusting and moving forward. We know that there will continue to be academic, behavioral, and social emotional needs that we will need to evaluate and determine the best support for through MTSS.

Comprehensive Support and Improvement

An LEA with a school or schools eligible for comprehensive support and improvement must respond to the following prompts.

Schools Identified

A list of the schools in the LEA that are eligible for comprehensive support and improvement.

We do not have any schools identified for CSI at this time.

Support for Identified Schools

A description of how the LEA has or will support its eligible schools in developing comprehensive support and improvement plans.

We do not have any schools identified for CSI at this time; however, all schools complete a School Plan for Student Achievement (SPSA) whether they receive Title I funding or not. As part of the development of that plan, schools conduct a needs assessment and work with the School Site Council to develop goals based on the analysis of that data. As part of the overall Multi-Tiered System of Support, schools identify specific, evidence-based interventions to support the targeted needs of students. A universal screener is used at each site with additional assessments as needed to determine flexible groupings which shift on a regular basis based on student need. In addition to clear expectations for first, best instruction in Tier 1, the district continues to refine supports in Tier 2 and 3 each year based on analysis of the data to determine gaps and the greatest areas of need.

Monitoring and Evaluating Effectiveness

A description of how the LEA will monitor and evaluate the plan to support student and school improvement.

Again, while we have no schools in CSI, we do require a plan from each site that is monitored throughout the year by the School Site Council including a mid-year and end-of-year review to determine if student needs are being met and if adjustments need to be made to the plan.

Engaging Educational Partners

A summary of the process used to engage educational partners and how this engagement was considered before finalizing the LCAP.

Each year, the Assistant Superintendent of Educational Services meets with educational partners to gather input for the Local Control Accountability Plan (LCAP). After analyzing assessment data from the prior year and information released on the California Dashboard in November, an LCAP Advisory Committee is formed that includes parents, staff, union representation, and SELPA representation. Meetings are scheduled from January-April to gather input from the LCAP Advisory Committee, the Parent Advisory Committee, DELAC, Cabinet, Instructional Leadership, staff, parents, students, and the unions for both certificated and classified staff. Regular updates are provided to the Board of Trustees and annual surveys are sent out in February to parents, staff, and students to gather additional information to develop the LCAP. Goals and Actions within the LCAP are regularly discussed at Administration meetings and as Principals develop their Single School Plan for Achievement (SPSA) to support the district in meeting its goals. Ultimately, the LCAP is posted on the district website for public input as well as presented for Public Hearing in June prior to LCAP approval by the Board of Trustees. In addition to the meetings and surveys this year, an online document (a Padlet) was created for stakeholders to post input on from February through May. Educational Partners were encouraged to email the Assistant Superintendent directly as well, and then the suggestions from these emails were added to the online document.

Input from all the various Educational Partners was shared with the LCAP Advisory Committee, and as a public document, the Padlet was available for all to see, comment on, and add to.

The following represents the formal meetings to gather input from various educational partners:

LCAP Advisory Committee: March 9 and April 27th, 2022 with the Letter from the Superintendent to be mailed in June
Parent Advisory Committee: February 2, March 9, and April 27th, 2022 with the Letter from the Superintendent to be mailed in June
DELAC: April 22, 2022
PTA: February 16, 2022 (Jordan), February 17, 2022 (El Portal), February 17, 2022 (Rancho Starbuck), January 20, 2022 (Olita), February 3rd 2022 (Meadow Green), January 13th, 2022 (Macy)
Staff Meetings: March 7th, 2022 (Meadow Green), April 21st, 2022 (Olita), March 4th, 2022 (Rancho Starbuck), April 4th (El Portal), March 17th, 2022 (Jordan), March 28th, 2022 (Macy)
CSEA: March 15, 2022
LJEA: April 12th, 2022
SELPA: Attended the LCAP Advisory meetings
STUDENTS: Survey of 497 students

These are in addition to the survey, regular updates at Board meetings, and discussion at regularly scheduled Instructional Leadership meetings which include Cabinet and all Principals. Additionally this year, the certificated union (LJEA) sent out an additional survey to gather input for the LCAP that was included in the padlet as teacher input that was shared throughout the process.

A summary of the feedback provided by specific educational partners.

A common theme for all Educational Partners continues to center around the need to address the social emotional learning of students with the continued difficulties in the 2021-22 school year related to trauma and the pandemic. Being disconnected from peers and the routines of school life in addition to experiencing the potential traumas associated with the pandemic (loss, food insecurity, change in living situation, unemployment, lack of supervision, etc.) has taken a toll on our students and families. Understandably, there is great concern around reconnecting kids and being sure their mental health and social emotional needs are being met. This was expressed by certificated and classified staff as well as parents in the desire for more counselors and psychologists to support the growing needs of students. It was echoed by students in two questions on their survey where 29% of students responding did not feel like they knew an adult they could talk to if they needed help and 23% do not feel like school is a place where they feel safe. Since 84% feel successful at school and 89% teachers treat them with respect, the connection issues seem to center around issues not entirely related to the academics of school. This is also reflected in the types of visits recorded by counseling interns to receive support related to areas other than academics.

Another common theme from staff and parents was the need to support intervention for students who still need extra support in developing skills they are lacking. The flip side to this is supporting the students who may also need enrichment opportunities both to challenge and engage them in extending what they have learned or already know even through the disrupted learning for their peers. Both parents and staff members are excited about the Expanded Learning Opportunities that will provide greater access and resources before and after school, which also allows us to use existing funds on similar opportunities in the day. Having structured Art and Physical Education programs that can support social emotional learning was brought up multiple times as an important part of offerings in the planning for next year.

Parents in particular have voiced the need for preschool and additional early learning opportunities. The desire for expanded hours in the Learning Link from the first day it opened is a good indication of how important the need is for these types of opportunities as is the request to have it open all summer long. Also voiced by parents is the desire for the increased enrichment activities around STEAM and the more formalized GATE identification and opportunities for students.

Some of the priorities for teachers included classroom furniture, books for the classroom and libraries, and finally, art and physical education support. There are a number of other items on the survey that can be addressed without specific reference in the LCAP such as access to supplies.

A description of the aspects of the LCAP that were influenced by specific input from educational partners.

With the above in mind, the district is maintaining specific goals around enrichment (Goal 5), early literacy (Goal 2), and social emotional well-being (part of Goal 4) to focus on these areas over the next few years. This is in addition to the goals that describe maintenance of basic operations, facilities upgrades which have been and continue to be in the forefront of the community, and the overall Multi-Tiered System of Support (MTSS) that continues to expand in order to meet the needs of every student within the Lowell Joint community. The LCAP continues to prioritize funding for Early Literacy under Goal 2 that includes the development of two preschools (including state-funded slots). The Learning Link will continue under the funding from First Five, and we will look for ways to increase the number of families served. The

continued focus on social emotional health and well-being through the use of counseling and psych interns along with resources for teachers in the classroom is reflected in Goal 4 under the Multi-Tiered System of Support. We have also developed a partnership with the Muckenthaler Center to increase art opportunities and provide more formalized art instruction at the elementary level. We are piloting a few options to address the desire for more support with physical education, so we can finalize plans after some feedback on those options. Some of the intervention and enrichment supports are documented in Goals 4 and 5 while much of this is being developed as part of the Expanded Learning Opportunities Plan. As this unfolds over the next year, additional offerings will be reflected in the LCAP based on the needs assessment of our families for programs and supports. Some items have already been addressed. For example, one parent asked about the installation of marquees that are being installed this summer, so that was not included as a specific item in the LCAP. The entire list of feedback has been provided to the Board and Cabinet so that while prioritized items from the LCAP Advisory Committee are directly reflected in the LCAP, additional suggestions can also be managed.

Goals and Actions

Goal

Goal #	Description
1	All students of the Lowell Joint School District will have appropriate conditions for successful learning outcomes.

An explanation of why the LEA has developed this goal.

This goal addresses the basic conditions necessary to open the doors of our schools and support the successful learning of our students. Staffing and basic operations are accounted for here to address the Local Control Funding Formula (LCFF) State Priority #1, which is Basic (Conditions for Learning). In addition, evidence for the sufficiency of materials to address the LCFF State Priority #2 Implementation of State Standards (Conditions for Learning) is also included. Beyond just having materials, staff are surveyed each year to determine their level of comfort with implementing state standards. Additionally, given the need for proficiency in technology, digital resources as part of core programs, and the changes in instructional practice due to the recent school closures, access to devices and the internet have become a part of ensuring that students have access to the resources they need to be successful with state standards. Partnering with parents is a critical component to ensuring success for our students, which is LCFF Priority #3 Family Engagement. Parents are actively involved in the school community through School Site Council, PTAs, volunteer opportunities, and parent training. This also addresses all five Board Goals: Fiscal Excellence, Academic Excellence, High quality staff providing high quality service, and Safe, orderly, positive, respectful learning environments, and School/Family/Community Partnerships and Communication.

Measuring and Reporting Results

Metric	Baseline	Year 1 Outcome	Year 2 Outcome	Year 3 Outcome	Desired Outcome for 2023-24
Credential Audit and data from CBEDS	One teacher has an Internship Credential working on a full credential with another on a short-term Staffing Permit working toward an Internship Credential and then a full credential. All remaining teachers were fully credentialed	All teachers were fully credentialed and appropriately assigned in the 2021-2022 school year.			All teachers will be fully credentialed and appropriately assigned.

Metric	Baseline	Year 1 Outcome	Year 2 Outcome	Year 3 Outcome	Desired Outcome for 2023-24
Board minutes for William's sufficiency	Every student has standards-aligned materials as measured by Williams compliance documentation.	Every student has standards-aligned materials as measured by Williams compliance documentation. This was affirmed at the Board meeting in October of 2021 and the minutes are posted on the district website.			All students will continue to have standards-aligned materials.
Certificated staff survey on implementation of standards	94% of certificated staff members who teach core content areas said they Agree or Strongly Agree with the statement "I am comfortable in my understanding and implementation of California State Standards" as measured by the annual teacher survey.	The district average dropped to 88% this year which in part may be due to the piloting and focus on new science materials with NGSS. Based on survey results, 100% of teachers at Rancho are comfortable with state standards with the average for the elementary sites being 86%.			95% of certificated staff members who teach core content areas will Agree or Strongly Agree with the statement "I am comfortable in my understanding and implementation of California State Standards".
Distribution of devices and hot spots (as needed) to ensure access to instructional resources to support	All students were provided a device in the 2020-2021 school year due to distance learning. When	All students were provided a device in the 2021-2022 school year for use in the classroom with			All students will have access to devices and internet to support progress on state standards and

Metric	Baseline	Year 1 Outcome	Year 2 Outcome	Year 3 Outcome	Desired Outcome for 2023-24
the development of proficiency in state standards.	students are back on campus, a system has been created to assign devices for those in need while continuing to provide devices within each classroom for student use. Qualifying families will also be able to check out a hot spot and/or be connected with low-cost internet providers.	devices checked out to 7th and 8th grade students. TK-6th grade students needing access at home were able to check out a device. Qualifying families were also able to check out a hot spot and/or be connected with low-cost internet providers. 99.3% of families stated they had access to technology and received communication from the district.			proficiency in 21st century skills.
Documentation of training for SSC and DELAC members including the minutes, sign ins, and presentation materials Parent involvement in the LCAP process as documented through sign-in sheets to ensure representation of parents of UDPs along with regularly scheduled meetings for parent input in	SSC and DELAC training was conducted in the year prior to COVID. Training will be scheduled for the fall of 2021 for each site as part of parental input into the decision-making process for the development of SPSAs and the LCAP. Virtual meetings were calendared in the 2020-2021 school	At the beginning of the year, Principals reviewed roles and procedures with their respective School Site Councils. The role of the DELAC in providing input in the decision-making process for the LCAP was discussed at the DELAC meeting in April where input for the LCAP was solicited in addition to information on the			SSC and DELAC training is conducted every other year to ensure parent participation in the decision-making process. Meetings will be calendared each school year including the potential for reaching a wider audience by continuing with virtual options. Sign in

Metric	Baseline	Year 1 Outcome	Year 2 Outcome	Year 3 Outcome	Desired Outcome for 2023–24
<p>"Coffee with Coombs" at each site.</p> <p>Attendance at PTA meetings by district staff to connect with parents and support efforts to involve the parents of UDPs .</p>	<p>year with limited participation. Digital sign in sheets were maintained to document participation.</p> <p>Sign in sheets document the participation of district staff at regularly scheduled PTA meetings along with the PTA Council meetings for La Habra.</p>	<p>Consolidated Application and Title III funding specifically.</p>			<p>sheets will be maintained to document participation.</p> <p>Sign in sheets will document the participation of district staff at regularly scheduled PTA meetings along with the PTA Council meetings for La Habra</p>
<p>Survey Results</p>	<p>95% of the parent respondents marked "Agree" or "Strongly Agree" with the statement, "I feel welcome at my student's school".</p> <p>97% of the parent respondents marked "Agree" or "Strongly Agree" with the statement, "I receive information about my student's academic performance through report cards, progress reports, email, parent-</p>	<p>94.6% of the parent respondents marked "Agree" or "Strongly Agree" with the statement, "I feel welcome at my student's school".</p> <p>95% of the parent respondents marked "Agree" or "Strongly Agree" with the statement, "I receive information about my student's academic performance through report cards, progress reports, email, parent-</p>			<p>95% or more of parent respondents marking "Agree" or "Strongly Agree" with the statement, "I feel welcome at my student's school".</p> <p>97% or more of parent respondents marking "Agree" or "Strongly Agree" with the statement, "I receive information about my student's academic performance through report cards, progress</p>

Metric	Baseline	Year 1 Outcome	Year 2 Outcome	Year 3 Outcome	Desired Outcome for 2023-24
	<p>notification letters, and/or parent conferences/phone calls".</p> <p>93% of the parent respondents marked "Agree" or "Strongly Agree" with the statement, "Our school is safe, orderly, and well disciplined".</p> <p>88% or more of students will "Agree" or "Strongly Agree" with the statement "I feel safe at school" and "I have opportunities to connect with my school".</p>	<p>notification letters, and/or parent conferences/phone calls".</p> <p>93.9% of the parent respondents marked "Agree" or "Strongly Agree" with the statement, "Our school is safe, orderly, and well disciplined".</p>			<p>reports, email, parent-notification letters, and/or parent conferences/phone calls".</p> <p>93% or more of parent respondents marking "Agree" or "Strongly Agree" with the statement, "Our school is safe, orderly, and well disciplined".</p> <p>92% or more of students will "Agree" or "Strongly Agree" with the statement "I feel safe at school" and "I have opportunities to connect with my school".</p>
Survey Results Sign Ins	<p>94% of parents responded Agree or Strongly Agree to the statement "I am aware of parent involvement opportunities such as School Site Council, English Learner Advisory Committee (ELAC), Parent Teacher Association</p>	<p>88% of parents responded Agree or Strongly Agree to the statement "I am aware of parent involvement opportunities such as School Site Council, English Learner Advisory Committee (ELAC), Parent Teacher Association</p>			<p>95% or more of parent respondents marking Agree of Strongly Agree with the statement "I am aware of parent involvement opportunities such as School Site Council, English Learner Advisory Committee</p>

Metric	Baseline	Year 1 Outcome	Year 2 Outcome	Year 3 Outcome	Desired Outcome for 2023–24
	<p>(PTA), Back-to-School Night and Open House, and I have multiple opportunities to be involved in my child's education".</p> <p>Monitor sign ins and participation for SELPA involvement, meeting attendance, and the percentage of families of UPPs engaged in activities and decision-making committees.</p>	<p>(PTA), Back-to-School Night and Open House, and I have multiple opportunities to be involved in my child's education".</p>			<p>(ELAC), Parent Teacher Association (PTA), Back-to-School Night and Open House, and I have multiple opportunities to be involved in my child's education".</p> <p>Once a baseline is established (since the data is not currently aggregated across multiple meetings), there will be a 5% increase in the number of families actively involved in activities and committees across the district.</p>

Actions

Action #	Title	Description	Total Funds	Contributing
1.1	Certificated Staffing-Teachers	Fully credentialled teachers will be employed and appropriately assigned. This includes some teachers that support unduplicated pupils; however, those services are documented elsewhere within the Local Control Accountability Plan (LCAP). Where the documentation of services is provided, the expense is identified as a repeated expenditure.	\$16,991,483.00	No

Action #	Title	Description	Total Funds	Contributing
1.2	Certificated Staffing-Administration and other Support Staff	This includes certificated personnel working at the district office, Principals, the Assistant Principal at Rancho Starbuck, School Psychologists, and SLPs (Speech and Language Pathologists).	\$3,172,344.00	No
1.3	Classified Staffing-Technology Department	The Technology Department, consisting of three full-time and one part-time employee, will oversee the District's technology needs. This includes monitoring the networks and infrastructure for access to the internet and online testing for the state. With the Chromebook Initiative, maintenance and support of devices is an ongoing need. Go Guardian was implemented as well across the district to allow teachers the ability to monitor students on their Chromebooks for added safety. Communication tools such as websites, phone, and email systems will also be maintained by the Tech Department as will safety and security measures such as Raptor which was purchased for implementation in the 2018-19 school year. Raptor is an electronic check in system for all people visiting a campus that alerts staff to potential issues with a visitor. Catapult is an emergency management system for communication during emergency situations such as a lock down, which is also managed by the Tech Department. It allows for better coordination with outside emergency personnel such as police and fire as well as internally for teachers to account for students. Tech staff also work with students in specialized opportunities to learn about technology such as drones, programming, and robotics.	\$465,378.00	No
1.4	Classified Staffing-Custodial, Maintenance, and Grounds	Provide basic custodial, maintenance, and grounds services.	\$1,773,857.00	No
1.5	Basic Utilities	Basic utilities including electrical and water.	\$830,328.00	No
1.6	Instructional Materials-Textbooks and Software	In order to ensure that all students have standards-aligned instructional materials, the district has a Textbook Adoption timeline to plan for the expenditure of funds to stay in alignment with the release	\$313,567.00	No

Action #	Title	Description	Total Funds	Contributing
		of new frameworks under the state adoption cycle. This also includes the purchase of any necessary supplemental materials and software programs that are part of the overall instructional program designed to support progress on mastery of state standards. For the 2021-2022 school year, we anticipate the purchase of new science materials since the pilot was interrupted in the 2020 school year. Software items included here are those purchased by the district that directly impact student progress on standards and/or tools teachers use for instructional purposes within the classroom including Lexia, ST Math, SeeSaw, Kami, and Google Enterprise.		
1.7	Site Technology Allocation	Each school is provided with a technology allocation to update and expand equipment inventory with a priority placed on any teacher computer that is five or more years old. After those replacements have been made, the sites work with their site leadership teams to determine how best to use the funds in alignment with their identified needs and goals in their School Plan for Student Achievement (SPSA).	\$45,000.00	No
1.8	Instructional Supplies-Per Pupil Site Allocation	Each school was provided with a per pupil allocation for the purchase of instructional supplies. This allocation is based on overall enrollment at the site as calculated from CBEDS data in October. It is adjusted each year in alignment with the Consumer Price Index (CPI).	\$271,180.00	No
1.9	Maintenance of Chromebooks	Maintain and refresh devices from the first cycle of purchasing in 2015-16. As new Chromebooks are purchased, we have been able to expand the 1-1 Chromebook initiative for grades 3-8 to include the TK-2nd grade classrooms. With sending home devices during the pandemic, there is a greater need for replacement of devices in the coming year in addition to the anticipated need to refresh the older devices. The refresh of devices at Rancho Starbuck in 2021-2022 will allow distribution of those current devices into the lower grades. There	\$0.00	No

Action #	Title	Description	Total Funds	Contributing
1.10	Classified Staffing-Data Systems Analyst	With the increase in state-required reporting through CalPads in addition to the need for the management of the Student Information System (Aeries), it is necessary to maintain a classified position for the data input and monitoring. As a small district, this position also supports the monitoring of our unduplicated pupils in running queries and reports for English learners, Foster Youth, McKinney-Vento Youth, and low income families. That portion of the salary is accounted for under Goal 4, Action 14.	\$51,916.00	No
1.11	Single Plan for Student Achievement (SPSA)	SPSA goals will be shared at a regularly scheduled Board meeting including conclusions drawn from data analysis to highlight the unique needs of each individual school site. Each school will provide opportunities for parents to engage with the school community, attend trainings or parent nights designed to support the Home School Connection. These are outlined in the site's Single School Plan for Student Achievement (SPSA). As part of managing and tracking the action items and expenditures in the SPSA, we are looking to purchase Title 1 Crate from 806 Technologies to support the monitoring of services for our Unduplicated Pupils who drive the development of goals in the SPSA.	\$5,000.00	No
1.12	School Site Council and DELAC	Continue to provide annual training and/or refreshers for School Site Council members on their roles and responsibilities. Each Title I school will hold a Title I meeting to inform parents of opportunities for advisory groups and volunteerism. Schools will continue to implement an English Language Advisory Council (ELAC) or transfer the responsibilities to the School Site Council. The ELAC representative from the site along with other parents of English learners attend District English Language Advisory Committee (DELAC) meetings to	\$0.00	No

Action #	Title	Description	Total Funds	Contributing
1.13	Parent Teacher Associations (PTA)	Each school will continue to form a Parent Teacher Association (PTA) with district support to reach out to the parents of LDs. Meetings are scheduled both in the morning and in the evening to allow for greater attendance. PTAs strive to include parents in meaningful ways from event planning to roles within the PTA. At least once a year, district personnel attend meetings to discuss the LCAP in addition to parent meetings held by the Superintendent known as "Coffee with Coombs". Site Principals regularly attend meetings to provide information and receive feedback for planning purposes. The District will support the efforts of the La Habra PTA Council and each school will send a representative to the council meetings.	\$0.00	No
1.14	Family Engagement	Fund tools to support parent outreach: phone outreach system and websites for the district, sites, and teachers. The District will continue to offer trainings and/or institutes designed to partner with parents in supporting student success. An annual parent survey will be administered to provide parents with an opportunity for feedback and ideas for enhancing educational programs. The Director of Special Education will continue to support families in accessing resources and training through the SELPA to ensure our students with special needs are being supported.	\$34,647.00	No
1.15	Classified Staff-Administration and other Support	The costs associated with Office Managers, Fiscal Services, Attendance Clerks, and other classified support staff necessary for the basic operations at the district office and sites are included here.	\$2,696,003.00	No

Goal Analysis [2021-22]

An analysis of how this goal was carried out in the previous year.

A description of any substantive differences in planned actions and actual implementation of these actions.

There were no substantive differences related to this goal since the vast majority of action items for the basic operations of the schools are salary and benefits.

An explanation of material differences between Budgeted Expenditures and Estimated Actual Expenditures and/or Planned Percentages of Improved Services and Estimated Actual Percentages of Improved Services.

Once the budget is finalized, any material differences will be analyzed along with any changes in planned percentages for increased and improved services for unduplicated students (Foster Youth, English Learners, and students on Free/Reduced Lunch).

An explanation of how effective the specific actions were in making progress toward the goal.

All basic school functions were carried out over the course of the year even with all of the continued challenges from Covid 19. There are a few action items not related to salary that we need to continue to work on more effectively. We introduced Title I Crate this year to better organize documentation related to federal programs. In doing so, we noticed some areas for professional development that would be helpful for our Principals. With some of the changes to the Single Plan for Student Achievement (SPSA) and a few newer Principals, we are planning to provide some professional development around the comprehensive needs assessment (Goal 1.11). We have also noticed that there is some difficulty in identifying a representative from each site for the District English Learner Advisory Committee (DELAC). So while we provide training for SSC members, we need to support schools in strategies for increasing parent involvement (Goal 1.12). This feeds into another action item (1.14) around family engagement. We have made great connections with our Learning Link families this year in creating a community of support for the program. Our PTAs do a phenomenal job of partnering with us in support of our schools also. And yet, while we have many parents involved on site and in providing input for things like the LCAP, we frequently struggle with finding representatives for DELAC. We need to strategize ways to better involve out English Learner parents in the decision-making process.

A description of any changes made to the planned goal, metrics, desired outcomes, or actions for the coming year that resulted from reflections on prior practice.

There was a drop in the number of elementary teachers feeling comfortable with state standards based on the staff survey this year. Some of this can be attributed to piloting science materials that are much more connected to NGSS than existing programs in the district. Science work had begun before the pandemic in terms of unpacking standards and discussing shifts in content between grade levels; however, the piloting process was disrupted with Covid and the shift to distance learning. The district purchased some supplemental materials for science since the existing core programs did not have digital platforms. While this allowed us to continue with science instruction virtually, piloting the newer materials in preparation for a new adoption has deepened teachers understanding of science standards while creating some need for professional development in how to teach the new standards (Goal 1.6). As mentioned above, training in the comprehensive needs assessment and engaging our English Learner parents will be a focus for the coming year in order to increase representation on the DELAC.

A report of the Total Estimated Actual Expenditures for last year's actions may be found in the Annual Update Table. A report of the Estimated Actual Percentages of Improved Services for last year's actions may be found in the Contributing Actions Annual Update Table.

Goals and Actions

Goal

Goal #	Description
2	Early Literacy

An explanation of why the LEA has developed this goal.

As the community needs have shifted over the last few years, it has become evident that Lowell Joint needs to provide more opportunities to develop school readiness skills for incoming students. Over the last few years, Transitional Kindergarten classes have been opened at each elementary site. The district also runs a preschool to service students with special needs. Prior to the school closures in March of 2020, the district had applied for and received a fundable score for a state-funded preschool program. With two preschools in the area closing even before the pandemic, this was identified as a need from our families. With the freezing of funding to new programs in March of 2020, we were unable to move forward with a preschool at that time. We became involved with the First Five Orange County: Children and Families Commission when asked to administer the Early Developmental Index (EDI) to Kindergarten students in order to provide comprehensive data for the city of La Habra. This led to discussions about using the information for our district with the need to include our Los Angeles county schools as well. First Five LA and First Five OC were able to work together to fund this for our district prior to the pandemic. First Five OC provided consultants to support the writing of our application for a state-funded preschool, and ultimately, First Five OC included us in their last round of funding so that we received an Early Childhood grant to develop programs and services to better support early literacy. So while the district is still on hold with state-funding for a preschool, we have continued to move forward with planning to better meet the early literacy needs of our community. A Teacher on Special Assignment (TOSA) was hired to support the deliverables for the grant and provide professional development around early literacy needs within the district. During the school closures, our primary grades were the most impacted in terms of attendance and engagement. Our Kindergarten student had a chronic absentee rate of over 9% with both 1st and 2nd grades above 6%. This is significantly higher than the other grade levels that ran between 2-4% for a district average of 4.34%. Given that we may have additional students that postponed entry into schooling due to the pandemic along with the disrupted schooling for many of our local preschools, we are anticipating this will be an area of greater focus through the cycle of this LCAP at minimum. This goal helps to address the LCFF State Priority #2 Implementation of State Standards (Conditions for Learning) as well as State Priority #4 Pupil Achievement (Pupil Outcomes). This also addresses the Board Goals of Academic Excellence and School/Family/Community Partnerships and Communication.

Measuring and Reporting Results

Metric	Baseline	Year 1 Outcome	Year 2 Outcome	Year 3 Outcome	Desired Outcome for 2023–24
Early Childhood Accountability Plan	The Early Childhood Leadership Team has	The Early Childhood Leadership team has			The three-year plan will have been

Metric	Baseline	Year 1 Outcome	Year 2 Outcome	Year 3 Outcome	Desired Outcome for 2023–24
and quarterly updates on progress.	<p>met to develop the beginnings of the Early Childhood Accountability Plan. Quarterly updates were provided during the 2020-2021 school year; however, progress on some goals was delayed due to school closures including the opening of a state-funded preschool. The hope is to complete the plan in the coming year with programs and services beginning in the 2021-2022 school year.</p>	<p>monthly meetings to revisit goals and determine next steps to enhance our work with programs and resources to support families in early childhood. The Learning Link, Fun Physical Friday, Young Essential Scholars (YES) Newsletter, Early Developmental Index (EDI) brochure, Ready4K mobile application, Help Me Grow parent forums (both in English and Spanish) and LJSD Learning Link website are programs and resources that are currently in place and examples of ways we serve our families in the 2021-2022 school year. The ECLT also uses the Program Guidance Tool and Early Childhood Accountability Plan to celebrate accomplishments and determine next steps</p>			<p>developed and implemented including quarterly updates to the plan.</p>

Metric	Baseline	Year 1 Outcome	Year 2 Outcome	Year 3 Outcome	Desired Outcome for 2023-24
Agendas and Minutes from the Early Childhood Leadership Team.	The agendas and minutes from the 2020-2021 school year reflect the initial planning of this group for reaching out to engage stakeholders to help develop the vision and plan for early literacy within Lowell Joint. The committee includes primary teachers, a principal, the district nurse, various other district personnel, parents, and community members to support outreach to families with children ages 0-5 that are not enrolled within our school system.	in ongoing efforts to support families that are aligned with the First 5 deliverables. The 2021-2022 agenda and minutes are ongoing reflections of the work completed with the diverse Early Childhood Leadership Team. With the new Universal Pre-Kindergarten plan, the team has added new members to include educators and staff representative of the P-3 alignment. An Early Childhood Program Coordinator has been hired to oversee the planning and implementation of UPK in LJS for the 2022-2023 school year including the support for opening of two preschools, learning link and other resources to support families and with children ages 0-5. The California State Preschool Program			The Early Childhood Leadership Team will continue to assess data around the needs of our early learners and their families to develop programs and connect families with resources to support school readiness.

Metric	Baseline	Year 1 Outcome	Year 2 Outcome	Year 3 Outcome	Desired Outcome for 2023-24
<p>Data from Constant Contact for Newsletters and Brochures with Early Literacy Information; Participation with Ready4K</p>	<p>The Early Literacy Teacher on Special Assignment (TOSA) has begun sending out newsletters through Constant Contact and is developing a brochure to support parents with understanding developmental milestones for early learners. There are 58 participants signed up to receive monthly newsletters after initial emails to staff and parents. Ready4K licenses have been purchased with 47 people currently signed up to receive weekly texts with activities and information for parents targeting the specific ages of their children.</p>	<p>application has been submitted with hopes to offer both fee based and state funded preschools.</p> <p>The Early Literacy Teacher on Special Assignment (TOSA) uses the Young Essential Newsletter (YES) to share programs and resources to support families. We have increased to 70 participants. We went from a monthly newsletter to a quarterly newsletter and strategically provided activities, community based programs, information linked to the Early Developmental Index (EDI) to inform families on ways to support their child with age appropriate kindergarten readiness resources. Using data from the Early Developmental Index (EDI), a informational brochure</p>			<p>Data from Constant Contact and Ready4K will show an increase in the number of families subscribed to these resources.</p>

Metric	Baseline	Year 1 Outcome	Year 2 Outcome	Year 3 Outcome	Desired Outcome for 2023–24
		<p>on a domain (Gross and Fine Motor Skills) was developed to support families in both English and Spanish. This brochure also offers easy activities linked to various ages to guide parents/guardians in ways to support their child in this area. This brochure is shared at our Learning Link, our collaborative and community providers build awareness around the current data. The data for Ready 4K indicates that over 4000 text messages and 500 custom messages have been delivered to our participants related to curriculum developed for their child.</p>			
Sign-ins to document parent involvement in the Learning Link.	The Learning Link has not opened yet, so we have no data.	A google form for registration of participation in the Learning Link is used to collect information about families and			Parents will regularly make use of the Learning Link to build school readiness skills in children ages 0-5.

Metric	Baseline	Year 1 Outcome	Year 2 Outcome	Year 3 Outcome	Desired Outcome for 2023–24
Enrollment in the preschool program.	The preschool program has not opened yet. A for-fee option is being developed for the beginning of the 2022 year with the potential for a state-funded preschool should	their child. Our Aeries data base tracks attendance of families attending the Learning Link, We currently have 50 families participating in our Learning Link on a regular basis. Due to high levels of participation and limited space we have 12 families a day with outdoor Fun Physical Fridays with a focus on gross and fine motor skills with 30 participating families. We have increased our Instructional aide form 10 hours to 15 hours and now 18 hours to meet the demand and hope to increase next year at various school sites.			All slots within a for-fee and/or state-funded preschool will be filled to provide support for our earliest learners.

Metric	Baseline	Year 1 Outcome	Year 2 Outcome	Year 3 Outcome	Desired Outcome for 2023-24
	<p>funding become available.</p>	<p>of 24 fee based and 24 state funded spaces for our LJSD families. (LJSD re-applied for a state funded program) We did open a Learning Link in October of 2022 to serve families with spaces limited to 12 using some of the First 5 funds to hire an instructional aide to facilitate learning with parents/guardians and their children in activities linked to Kindergarten readiness. With growing demand our Learning Link plus Fun Physical Friday is up to 12 families a day and is serving 48 families with children ages 0-5 years old.</p>			
<p>Attendance at and implementation of professional development around language acquisition as measured by sign-sheets, classroom observation and ongoing coaching.</p>	<p>While many of the teachers attended training in OCDE Project GLAD in 2013-14 and 2014-15, there has not been any follow up. Additionally with many new staff in the district over the</p>	<p>In the 2021-2022 school year there has been a shortage of substitute teachers thus having an impact on the opportunities for professional development. We were able to have</p>			<p>All teachers will have attended both the initial 2-day training and the 4-day demonstration for OCDE Project GLAD. In addition, regularly scheduled follow up sessions will be</p>

Metric	Baseline	Year 1 Outcome	Year 2 Outcome	Year 3 Outcome	Desired Outcome for 2023-24
	<p>last 6 years, a number of people need to attend the initial 2-day training and the 4-day demo. Eight teachers attended the 2-day in June of 2021.</p> <p>A google site was started to provide resources across grade levels that is specific to the implementation of OCDE Project GLAD within Lowell Joint</p>	<p>another 2 Day Research and Theory training for GLAD with 8 additional participants. In addition, we continue to provide resources and support through the TOSA Newsletter and Google Site specifically focusing on high impact strategies to support listening, speaking, reading and writing across the grade levels. Planning efforts for the 2022-2023 school year are to have opportunities to offer the initial 6 day training and follow up during the summer and school year as well as after school. The TOSA has specific time allocated for teacher support, modeling of strategies and coaching in daily schedule.</p>			<p>provided along with in-class modeling and coaching by the Early Literacy TOSA who is also a trainer for OCDE Project GLAD. Implementation by teachers is clearly evident through the artifacts within the room and shared resources developed by teachers in on the google site.</p>

Actions

Action #	Title	Description	Total Funds	Contributing
2.1	Early Literacy Teacher on Special Assignment (TOSA)	The Early Literacy Teacher on Special Assignment (TOSA) is responsible for coordinating the development of the Early Childhood Accountability Plan and its deliverables while also supporting teachers with strategies for the development of literacy. This includes the actions specifically identified within the LCAP as well as those in the Early Childhood Accountability Plan that is required by the grant funding from First Five Orange County. The Early Literacy TOSA will work with teachers on identifying areas of need through the data gathered in the Early Developmental Index and district-wide benchmarks. This is especially important in returning from disrupted schooling to ensure that the foundational skills developed in the primary grades are addressed in supporting students with proficiency in reading and writing.	\$135,906.00	Yes
2.2	Early Literacy Committee	Convene an Early Childhood Leadership Team that will develop an Early Childhood Accountability Plan (ECAP) with evidence of implementation and support.	\$1,000.00	No
2.3	Early Literacy-Community Engagement	The following include strategies identified for engaging with community providers, parent groups and individuals to support early learners with a primary focus on our families needing support with community resources and navigating school readiness: <ul style="list-style-type: none"> • Establish relationships with neighboring community providers, parent groups and individuals in the LJSJ district boundaries. • Develop ongoing communication with existing providers, parent groups and individuals to work collaboratively in supporting early learning. • Utilize YES (Young Essential Scholars) Newsletter to showcase community providers, parent groups and individuals that support early learners. • Provide a Learning Link for families to engage in meaningful activities linked to early learning. 	\$30,002.00	No

Action #	Title	Description	Total Funds	Contributing
		<ul style="list-style-type: none"> • Provide access to Ready4K to target resources to existing families and those with children ages 0-5 within our community. • Utilize quarterly informational brochure documenting early childhood milestones for families supporting children ages 0-5. 		
2.4	Early Literacy- Preschool Program and Learning Link	With approximately 40% of our families within Lowell Joint meeting the requirements for free and reduced lunch, there is a tremendous need to support our community with access to quality preschool at no charge. As the discussion began around opening a state-funded preschool, many additional families expressed an interest in having a fee-based program as well since we would be able to offer a program at less expensive rates than some of the local alternatives. We are in the process of applying for a preschool license so that we are able to move forward with a state-funded preschool as funds become available and explore the fee-based options. Until we are able to open a preschool program, we are preparing to open a Learning Link: a space where parents come with their children ages 0-5 to engage in activities designed to develop and support school readiness skills. The goal would be to have the space open for 10 hours a week.	\$56,000.00	Yes
2.5	Transitional Kindergarten	Transitional Kindergarten is not currently compulsory, however, those students who would not otherwise be enrolled in preschool or other school readiness programs prior to entry into Kindergarten are at a serious disadvantage without the opportunity to participate in activities designed to nurture and develop foundational skills.	\$632,359.00	Yes

Goal Analysis [2021-22]

An analysis of how this goal was carried out in the previous year.

A description of any substantive differences in planned actions and actual implementation of these actions.

There were no substantive differences.

An explanation of material differences between Budgeted Expenditures and Estimated Actual Expenditures and/or Planned Percentages of Improved Services and Estimated Actual Percentages of Improved Services.

Once the budget is finalized, any material differences will be analyzed along with any changes in planned percentages for increased and improved services for unduplicated students (Foster Youth, English Learners, and students on Free/Reduced Lunch).

An explanation of how effective the specific actions were in making progress toward the goal.

Based on all the measurable outcomes and feedback from First Five and OCDE in monitoring our progress around issues related to early learning, the specific actions have been very successful at beginning this journey. The number of positive comments we have received around the Learning Link are also indicative of heading in the right direction.

A description of any changes made to the planned goal, metrics, desired outcomes, or actions for the coming year that resulted from reflections on prior practice.

There are additions to the goal that will be fleshed out through the UPK plan and deliverables under the First Five grant, but there are no specific changes to the existing action items.

A report of the Total Estimated Actual Expenditures for last year's actions may be found in the Annual Update Table. A report of the Estimated Actual Percentages of Improved Services for last year's actions may be found in the Contributing Actions Annual Update Table.

Goals and Actions

Goal

Goal #	Description
3	Modernization and Maintenance of Facilities

An explanation of why the LEA has developed this goal.

The schools in Lowell Joint were built in the 1950s and 60s and are in desperate need of major maintenance and modernization. The District continues to prioritize facility needs, and with the passing of a bond in 2018 (Measure LL), there will be additional monies available to begin the modernization and upgrading of all sites over the next few years. The primary focus of the bond is related to roofing and HVAC with the associated electrical and plumbing. These additional dollars will allow District funds for maintenance to be used on other needs in the prioritized list. Facilities projects were identified beginning with the Olita Major Maintenance project that began in 2020. There was an unexpected vacancy at the Maybrook site within the district that had been leased to a private school. This allowed for the consideration of using that site as temporary housing for the six schools as the repairs to roofing and HVAC systems are completed. No students present on site allows for a faster construction timeline, which decreases the overall cost of the project. It also means students will not be disrupted during the day by construction. Olita was technically moved to the Maybrook campus at the beginning of the 2020 school year while we were still in distance learning. Because we were not able to return to in-person instruction until March of 2021, there was little disruption for students who were meeting virtually. Construction was completed on the Olita site and Macy was moved to Maybrook mid-year. With the work at El Portal being done over the summer, three of the six schools were able to complete major construction and modernization within about a year. This allowed the district to complete the issuance of the bonds, which ultimately saved the tax payers approximately five million dollars in addition to some construction savings. Jordan is being moved to the Maybrook site for the 2021-2022 school year. Meadow Green and Rancho Starbuck will follow after construction is completed at Jordan. Given that the primary purpose of the bond was to upgrade basic necessities (roofing, HVAC, electrical and plumbing), there is still much work to be done. The district will continue to address major areas for improvement in conjunction with the projects identified in the scope of work for the bond. This goal helps to address the Local Control Funding Formula (LCFF) State Priority #1, which is Basic (Conditions for Learning).

Measuring and Reporting Results

Metric	Baseline	Year 1 Outcome	Year 2 Outcome	Year 3 Outcome	Desired Outcome for 2023–24
Board agendas and minutes Bond Oversight Committee agendas and minutes	The Facilities Master Plan will be Board approved and implementation will begin with regular	The Facilities Master Plan was Board approved and implementation is monitored with regular			Identified timelines for priorities within the Facilities Master Plan will be met including

Metric	Baseline	Year 1 Outcome	Year 2 Outcome	Year 3 Outcome	Desired Outcome for 2023-24
SARCs and FIT Reports	updates to the Board of Trustees on progress. All school sites were inspected using the Facilities Inspection Tool (FIT) to ensure that facilities are in "Good Repair" or higher.	updates to the Board of Trustees on progress. All school sites were inspected using the Facilities Inspection Tool (FIT) to ensure that facilities are in "Good Repair" or higher.			projects completed under the bond. All school sites will continue to receive a "Good Repair" or higher marking on the annual FIT reports that are then reported in the School Accountability Report Cards (SARCs)
Board agendas and minutes Bond Oversight Committee agendas and minutes	Three of the sites have completed the scope of work identified in the bond with some additional district-funded work being completed in the summer of 2021 (marquees, painting).	Jordan is now completed (4th of 6 sites) and Meadow Green is moving to the Maybrook site for the 2022-23 school year.			All schools will have completed the work identified in Measure LL including new roofing, HVAC systems, and the associated electrical and plumbing. Some sites also required updated piping for sewer lines. Additional district-funded projects will be completed including marquees, painting, and water bottle filling stations.

Actions

Action #	Title	Description	Total Funds	Contributing
3.1	Facilities Master Plan	Given the scope of work necessary to support the aging facilities within the district, a Facilities Master Plan needs to be approved to prioritize the major maintenance projects in conjunction with the work being done through Measure LL. The primary focus of the bond is related to roofing and HVAC with the associated electrical and plumbing. These additional bond dollars will allow District funds for maintenance to be used on other needs on the prioritized list within the Facilities Master Plan. The plan will set the vision for the next 20 plus years as "Caretakers of a Legacy". The plan was developed over the last few years and is ready to be submitted for Board approval. Once approved, there will be regular updates to the Board. There are \$2,056,000 dollars budgeted for non-personnel expenses out of Fund 14, 25, and 40. These are not included in the general fund budget.	\$0.00	No
3.2	FIT Reports	Continue to inspect all school sites to ensure that facilities are in "Good Repair."	\$0.00	No
3.3	Measure LL-Bond	In November of 2018 the community passed a bond to support the much needed facilities work at each of the six sites. The scope of work is outlined in the Master Plan and the expenditures are documented here to support the ongoing work in meeting this goal beyond the use of general fund monies. There is \$13,267,359 budgeted in non-personnel for major maintenance and modernization for the 2021-2022 school year with an additional \$115, 392 in personnel. These costs are not included in the general fund budget since they are a reflection of the bond monies.	\$0.00	No

Goal Analysis [2021-22]

An analysis of how this goal was carried out in the previous year.

A description of any substantive differences in planned actions and actual implementation of these actions.

There were no substantive differences and the actions outlined in the bond measure and Facilities Master Plan are being completed and monitored regularly.

An explanation of material differences between Budgeted Expenditures and Estimated Actual Expenditures and/or Planned Percentages of Improved Services and Estimated Actual Percentages of Improved Services.

Once the budget is finalized, any material differences will be analyzed along with any changes in planned percentages for increased and improved services for unduplicated students (Foster Youth, English Learners, and students on Free/Reduced Lunch).

An explanation of how effective the specific actions were in making progress toward the goal.

The Bond Oversight Committee monitors the progress and expenditures of bond monies to ensure that the district is on target with meeting goals identified within the bond. The work at four sites has been completed ahead of schedule with since construction was able to begin early with school closures and no students on campus during the 2020-21 school year until the very end of the year. All schools were in "Good Repair" or higher on the current School Accountability Report Cards. There were only a few deficiencies noted across the district on SARCS: one for outdated playground equipment, one for pest/vermin in a field space, and some roofing issues. The roofing issues will be addressed through the bond, and the pest/vermin issue was already addressed through normal avenues in terms of increased services on the existing contract. The playground upgrades are a part of the overall discussion for Universal Pre-Kindergarten needs as well as general upgrades to be integrated into existing plans. The Facilities Master Plan was Board approved and regular updates are provided to the Board at both Board meetings and through weekly communication.

A description of any changes made to the planned goal, metrics, desired outcomes, or actions for the coming year that resulted from reflections on prior practice.

Two required state initiatives, Universal Pre-Kindergarten and Expanded Learning Opportunities, are creating the need to re-examine spaces throughout the district. The addition of two preschool classrooms and the need for space to run before and after school programs is requiring the sharing of spaces for multiple uses, which is not always conducive to the various programs using the space. Where this is an issue, we need to look at viable options for how to potentially increase space on campus while working within required guidelines from DSA or reconfigure spaces for better usage.

A report of the Total Estimated Actual Expenditures for last year's actions may be found in the Annual Update Table. A report of the Estimated Actual Percentages of Improved Services for last year's actions may be found in the Contributing Actions Annual Update Table.

Goals and Actions

Goal

Goal #	Description
4	In order to meet the unique academic, behavioral, and social emotional needs of all students, a Multi-Tiered System of Support (MTSS) will continue to be expanded and refined.

An explanation of why the LEA has developed this goal.

In order to meet the unique needs of all students within the Lowell Joint School District, there has been a focus on developing clear levels of support for students in academics, behavior, and social emotional learning over the last few years under the larger umbrella of a Multi-Tiered System of Support (MTSS). The work began with identifying district-wide initiatives to support first, best instruction in the classroom that would meet the needs of the majority of students. This is also known as Tier 1. Then additional supports (Tier 2 and Tier 3) were developed and layered in to address smaller, more targeted groups of students based on need. As those systems were put in place, we began to tackle the supports for Behavior and now Social Emotional/Mental Health needs. The overall system is constantly being refined based on data and the ever-changing needs of our student population. All stakeholders have expressed concern for student's growth and well-being as we return to campuses full time in the 2021-2022 school year. Specific, more targeted goals have been identified for the Social Emotional and Mental Health needs of students and for Early Literacy. While these fall within the Multi-Tiered System of Support, it was important to spotlight these areas given the current context for our students and the increased need in these areas. Just as important is the attention to potential changes in that first, best instruction that may need to take place to provide opportunities for learning around skill sets that may not have been fully developed due to interrupted schooling, changes in instructional practice in distance learning, and other barriers making learning difficult. So represented in this goal are some of the ongoing practices that have been successfully supporting students prior to the pandemic as well as additional actions designed to address both the greater number of students needing intervention and the varied challenges facing students in the coming years.

Refining our overall Multi-Tiered System of Support continues to be an ongoing means of addressing the needs of students at all levels. We are developing additional services and interventions for our English Learners and Students with Disabilities. While we maintained the supports from the prior year, there is clearly a need to provide additional intervention for students to close the achievement gap as opposed to maintaining growth. We are adding some additional counseling and psychological supports for our UDPs, which will allow for more targeted support and monitoring for these student groups that are below the overall average for the district. This is especially true for our English learners and Socioeconomically Disadvantaged students. We want to continue to monitor both the academic and socio-emotional needs of our Foster Youth as well. We are currently evaluating the data from the LAS Links assessment to determine the focus for our English learners next year. We had hoped to have the data in February for planning purposes, however, delays due to COVID and school closures did not allow for the this. With the close out of the year, we will look at the data as baseline information to plan with over the summer for beginning the 2021-2022 school year with any necessary adjustments to our English learner supports. This will also allow us to analyze current SBAC data and ELPAC Summative data, which is becoming available now, to make decisions for the coming year.

This addresses the LCFF State Priorities 2: State Standards (Conditions of Learning), Priority 5: Student Engagement (Engagement), Priority 6: School Climate (Engagement), Priority 7: Course Access (Conditions of Learning), and Priority 8: Other Pupil Outcomes (Pupil Outcomes). On a local level, this goal is designed to meet Board expectations around Academic Excellence, School/Family/Community Partnerships and Communication, High quality staff providing high quality service, and Safe, orderly, positive, respectful learning environments.

Measuring and Reporting Results

Metric	Baseline	Year 1 Outcome	Year 2 Outcome	Year 3 Outcome	Desired Outcome for 2023–24
California School Dashboard English Learner Progress Indicator (ELPI) ELPAC Data Las Links iReady Data	Roughly 48% of English learner students were making progress towards English Language proficiency in 2019 on the English Learner Progress Indicator. In the 2018-2019 year, we had 19% scoring well-developed (4) on the ELPAC and another 44% at moderately developed (3). We have current data for our 3rd-8th grade students with 19% still at the well-developed (4) on the ELPAC and another 36% at moderately developed (3) for 2021. We do not have the TK-2nd grade scores for 2021 from the state as of yet.	Students took 3 Diagnostic Tests this year. In a sampling of our EL students, 91% of our students have increased performance from Diagnostic 1 to Diagnostic 3. 40% of the students exceeded the typical growth, and of those, 32% exceeded the stretch growth, which works to support closing the achievement gap.			60% of English Learners will be making progress towards English language proficiency with 25% scoring well-developed and 50% at moderately developed. For the summative ELPAC, we would like to increase the number of students scoring at the well-developed range by 5% while also increasing those in the moderate range by 5%

Metric	Baseline	Year 1 Outcome	Year 2 Outcome	Year 3 Outcome	Desired Outcome for 2023-24
SBAC Data	For ELA, 23% of English learners met or exceeded the standard with only 16% in mathematics. This is in comparison to English only students with 64% meeting or exceeding the standard for ELA and 56% for mathematics.	Current data is not available for SBAC. Using our benchmark iReady data, we show that 91% of our EL students increased performance in ELA and 70% increase in their performance in Math.			To close the achievement gap while still raising achievement levels for all students, English learners will need to gain 5% each year with English only students gaining at least 2% in both ELA and mathematics.
Dataquest- Reclassification Rates	19% of students were reclassified in the 2020-2021 school year, which is well above LA county at 8.1% and the state at 8.6%.	We don't have new RFEP rates for 2021-22 from Dataquest at this time. We reclassified 59 students with the potential for a few more in the next few weeks as CAASPP scores become available.			Reclassification rates will remain above both county and state rates.
iReady Data	An initial diagnostic will be administered by September of 2021 since this is a new assessment system. From this, both goals and stretch goals will be determined for each student.	Students took 3 Diagnostic tests throughout the year and showed substantial growth. In ELA: August: 17% Above Grade Level Most Recent: 39% Above Grade Level			80% of students will meet their goals with 30% completing stretch goals. These numbers will be re-evaluated upon training within the system and monitoring growth over the first year of implementation.

Metric	Baseline	Year 1 Outcome	Year 2 Outcome	Year 3 Outcome	Desired Outcome for 2023–24
	<p>IReady data will allow us to track Spanish proficiency for our Dual Language students, which we have not done in the first 2 years of the program with a formal assessment tool.</p>	<p>August: 21% On Grade Level Most Recent: 20% On Grade Level Total moved from 37% on or above grade level to 60% MATH: August: 5% Above Grade Level Most Recent: 27% Above Grade Level August: 14% On Grade Level Most Recent: 21% On Grade Level Total moved from 19% on or above grade level to 48%</p>			<p>60% of Spanish learners will be making progress towards Spanish Language proficiency in alignment with our goal for developing English proficiency with our English learners. This may be adjusted after baseline data is gathered in the fall of 2021.</p>
<p>Professional Development records Classroom Observations</p>	<p>All teachers hired before the pandemic have been trained in Thinking Maps with 2 additional days in Write from the Beginning. 8 teachers hired after 2015 were trained in the 2-day Research portion of Project GLAD with the 4-day Demonstration scheduled for the fall</p>	<p>Teachers continue to utilize Thinking Maps and Write from the Beginning to support student growth in the area of writing and organizing thoughts. All trained teachers demonstrate the ability to implement GLAD strategies in their classroom as a way to support language acquisition</p>			<p>All teachers will be trained in both Thinking Maps and Write from the Beginning. All teachers will have been through both the 2-day and 4-day portions of Project GLAD training and a system of ongoing follow-up and coaching will be in</p>

Metric	Baseline	Year 1 Outcome	Year 2 Outcome	Year 3 Outcome	Desired Outcome for 2023-24
	<p>since all elementary teachers were trained in 2013-3015.</p> <p>All teachers hired before the school closures were trained in Explicit, Direct Instruction (EDI).</p>	<p>based on classroom observations by Principals.</p> <p>Teachers continue to use EDI strategies in the classroom to best support their instructional practices. This is something that is used in teacher evaluations to show teacher effectiveness and stay in line with the CA standards for teaching.</p>			<p>place to support implementation.</p> <p>All teachers will be trained in Explicit, Direct Instruction (EDI).</p>
<p>Absentee letters SARB packets Monthly Chronic Absentee lists Attendance rates Chronic absenteeism Middle school drop out rate</p>	<p>Letters are automatically generated in Aeries on the 3rd, 5th, 7th, 9th, and 13th absence to notify parents for both truancy and chronic absenteeism.</p> <p>One student was taken through the SARB process prior to school closures.</p> <p>Principals are given monthly Chronic Absentee lists to follow up with</p>	<p>Letters were automatically generated in Aeries on the 3rd, 5th, 7th, 9th, and 13th absence to notify parents for both truancy and chronic absenteeism.</p> <p>Some adjustments were made with the number of students required to quarantine/isolate multiple times due to Covid regulations, which would otherwise have resulted in</p>			<p>Continue to generate letters and monitor student attendance.</p> <p>All students who are severely chronically absent (more than 25% of days enrolled) will begin the SARB process.</p> <p>Principals will continue to receive monthly lists of chronically absent students as well as those in danger of becoming chronically</p>

Metric	Baseline	Year 1 Outcome	Year 2 Outcome	Year 3 Outcome	Desired Outcome for 2023-24
	<p>students. This is monitored along with the percentage of students chronically absent, the overall attendance rate, and the middle school drop out rate to measure student engagement.</p> <p>With the change in attendance protocols for the 2019-2020 school year, no P2 data was available, However, prior to the school closures in March we were on target in month 7 with about 96% attendance based on a query of attendance within Aeries.</p> <p>Because of the school closures in March of 2019, there is not a direct comparison point for Chronic Absenteeism on the CA Dashboard. However, SARB documentation for the county shows a rate of</p>	<p>identification as chronically absent.</p> <p>Principals were regularly given Chronic Absentee lists to follow up with students.</p> <p>Current attendance data within Aeries as of May 2022 shows an average attendance of 94.2% with a range from 91.84% to 95.76% between the six sites. Given the extreme number of students who experienced one or more quarantine/isolation experiences due to Covid, this is not surprising.</p> <p>We had no drop outs in the 2021-2022 school year.</p>			<p>absent to engage in preventative measures.</p> <p>Attendance rates will continue to be at 96% or higher.</p> <p>The Chronic Absentee rate will be less than 3% overall with significant student groups being no more than 5%.</p> <p>Maintain the drop out rate at less than 1% for middle school students.</p>

Metric	Baseline	Year 1 Outcome	Year 2 Outcome	Year 3 Outcome	Desired Outcome for 2023-24
	<p>4.34%. This is an average across all grade levels.</p> <p>We had no drop outs in the 2019-2020 school year.</p>				
<p>CREW logs Nurse Documentation of supports EL Goal Sheets (Intervention Coordinators)</p>	<p>To focus on the specific needs of our Foster Youth, low income (specifically Homeless), and our English learners, support personnel check-in regularly with these students and document contacts and any necessary supports to ensure both student engagement and success. Quarterly reports are generated to summarize the meetings held and review any identified needs.</p>	<p>Support of our Foster Youth, Homeless, and EL students was provided by support personnel through phone calls home, emails, work with students on campus, intervention throughout the school day, counseling, and peer tutoring.</p>			<p>Support staff will continue to meet regularly with Foster Youth, low income (specifically Homeless), and English learners to monitor progress academically, behaviorally, and socially to make any necessary adjustments to supports.</p>
<p>Suspension and Expulsion Rates</p>	<p>Due to school closures in March of 2019, there is not a direct comparison point on the CA Dashboard for</p>	<p>There were no expulsions in the 2020-2021 data reported from Dataquest with only 6 suspensions across</p>			<p>The overall suspension rate for the district will be less than 3% with no significant student group being higher</p>

Metric	Baseline	Year 1 Outcome	Year 2 Outcome	Year 3 Outcome	Desired Outcome for 2023–24
	suspensions and expulsion rates. However, we had no expulsions and a 1.6% Suspension Rate reported on Dataquest for the 2019-2020 school year.	the district for a .2% suspension rate. This is partly driven by distance learning with no students in person for a significant chunk of the year.			than 6%. The district will continue to maintain less than 1% in expulsions.

Actions

Action #	Title	Description	Total Funds	Contributing
4.1	Professional Development (District-wide)	Provide non-student work days for professional development opportunities beyond early-release Mondays. These days are focused on intensive professional development to close the achievement gap for unduplicated pupils. The focus prior to the pandemic was on Thinking Maps as a foundation to the Write from the Beginning program since writing is an identified need for Unduplicated Pupils across the district. Having the ability to use nonlinguistic representations of complex thinking to remove language barriers is a critical component in supporting our English learners. Another training component will be the new iReady assessment system to support the identification of student needs for both intervention support and enrichment opportunities. Woven within these days will also be training for the social emotional side of our most vulnerable students in reconnecting after the pandemic. This includes our students from low income households along with our English learners who were especially impacted by the school closures. Early-release Mondays will also be used for training in social emotional learning, iReady, and Thinking Maps, along with collaborative planning time.	\$420,000.00	Yes

Action #	Title	Description	Total Funds	Contributing
4.2	Professional-Development-English Learners	Continue to provide ELD training so that EL students will be provided appropriate access to the California Content Standards based on data analysis of ongoing needs for our students in alignment with best practices. This includes support for the district-wide initiative in implementing OCDE Project GLAD (Guided Language Acquisition Design). Training will also include support for teachers in understanding the ELD Standards along with strategies for both Designated and Integrated ELD.	\$35,000.00	Yes
4.3	Progress Monitoring and Support of English Learners	In addition to teachers who provide Designated English Language Development (ELD) and Integrated ELD on a daily basis as part of Tier 1 instruction, four Bilingual Aides provide additional support to both students and parents. All 3-8 grade English learners track their own academic and language progress with goal sheets, and teachers will monitor the progress of English learners every trimester and/or quarter with interventions implemented as appropriate. Our Bilingual Aides work directly with students under the supervision of certificated staff in addition to supporting teachers with pulling the data from Aeries for monitoring and tracking student progress. Teachers meet with students and parents during conference time to discuss English learner progress. The aides complete the basic data portion (assessment scores, enrollment, etc.) Intervention Coordinators at each site meet one-on-one with English learners to support the development of their goals after discussing progress data on local measures and/or state assessment data. All English learners (including those reclassified that are still being monitored for progress), are given a language assessment to track language proficiency and provide additional supports as needed. This has been done through Las Links as an additional assessment specific to our English learners.	\$233,969.00	Yes
4.4	Dual Immersion Program	The district developed a Dual Immersion Program two years ago both to support our English learners and provide the opportunity for English only students to develop a second language. There are currently 4	\$455,589.00	Yes

Action #	Title	Description	Total Funds	Contributing
		grades available (TK-3rd grade) with 4th being added in the 2022-23 school year. iReady also includes assessments in Spanish that will allow us to better track students on their Spanish language proficiency. Spanish fluency will be assessed using Las Links in the coming year. All new core materials have been purchased for the program to better address Spanish language standards and support differentiation based on student needs.		
4.5	ELD, Reading Intervention, and Spanish Elective at Rancho	In addition to a double block of English for all students, English learners at Rancho Starbuck are included in an English Language Development elective to increase language proficiency before entering high school. We typically have less than 15 long-term English learners across the entire district, but the added support helps to prepare students for the increased language demands at both the intermediate and high school levels. A Spanish elective allows for a cognitive break in the day for English learners who are also in need of developing Spanish language proficiency. Some English only students are also in the class to develop beginning Spanish, which also allows native Spanish speakers the opportunity to support their English only peers.	\$53,584.00	Yes
4.6	Before and After School Intervention	Continue to hire staff to provide for extended day intervention classes principally directed toward the needs of our UPPs. We are looking at ways to increase the number of staff available and/or to partner with outside agencies to provide targeted support for our students needing tutoring.	\$80,000.00	Yes
4.7	Intervention Coordinators	Continue to fund stipends for each school to hire an intervention coach. Coaches meet throughout the year with district personnel to discuss MTSS and needed adjustments to support our Unduplicated Pupil needs. They have been trained in Illuminate to run reports to facilitate the analysis of data in monitoring our subgroup populations to determine groupings for intervention and to identify gaps in supports	\$21,821.00	Yes

Action #	Title	Description	Total Funds	Contributing
		with a primary focus on our English learners, Foster Youth, Homeless, and low income students.		
4.8	Intervention Support During the Day	As part of differentiation within the classroom, teachers provide support to students in making progress toward identified goals. For our English learners, Bilingual Aides provide push-in support for language development. Elementary sites with Title I funds have hired an Intervention Aide in addition to other intervention supports within the day. The District had provided an aide for each site during the 2021-22 school year with one-time dollars to support the most struggling students in closing some of the gaps created from the prior year.	\$110,000.00	No
4.9	Teacher Planning/Choir Teacher	Teachers will collaborate regularly to monitor student progress, dialogue about best practices, and design intervention programs. This includes an FTE for a music teacher, which allows for additional collaboration time at the elementary level during music instruction while also increasing student access to the Arts.	\$98,437.00	No
4.10	Classified Staff- Instructional Assistants & Special Ed Support Aides	These assistants and aides provide direct support to our students with special needs. This can include one-on-one instruction or guided practice, small group support, support for a specific student while mainstreamed, and work within a self-contained classroom.	\$1,139,144.00	No
4.11	Math Intervention- Rancho Starbuck	Maintain Math intervention sections at the intermediate school for targeted students (one seventh grade section and one eighth grade section).	\$37,535.00	Yes
4.12	Illuminate	Continue to fund a technology program/system to assist teachers in monitoring student progress and analyzing data to close achievement gaps for UDPs (Illuminate). We are in the process of evaluating the	\$25,000.00	Yes

Action #	Title	Description	Total Funds	Contributing
		need for this with the addition of iReady. Aeries is our student information system, so Illuminate is an additional resource.		
4.13	Reading Intervention-Rancho Starbuck	Maintain sections to the Rancho Starbuck master schedule for reading intervention (one for grade 7 and one for grade 8).	\$40,000.00	Yes
4.14	Coordination of Services	Coordination and administration of all programs funded through Supplemental Grant dollars. This includes monitoring the progress of Unduplicated Pupils (UDPs) by certificated personnel at the District Office. With the growing supports and services from the inception of LCFF for our Unduplicated Pupils (from just over \$230,000 to over \$2 million), there is a need to add an additional classified person in fiscal services related to the administration of program actions and expenditures. This also includes half of the classified salary for our Data Systems Analyst position to provide aggregated and disaggregated data for the LCAP, reports to principals each month on attendance, chronic absenteeism, and suspensions, and support for monitoring each of the unduplicated pupil groups so that students are receiving appropriate services. The remainder of that salary is in Goal 1, Action 10.	\$243,769.00	Yes
4.15	ABA Class and Program Specialist Position	Both a Program Specialist and an ABA Teacher are funded to increase overall services and opportunities for students struggling with behavior. The primary goal is to re-engage students in meaningful learning opportunities by providing intervention for behavior, mental health, and other nonacademic barriers to learning.	\$275,349.00	No
4.16	Learning Hubs-Libraries	School libraries will continue to be open additional hours to provide homework and tutoring help. This is in addition to their regular duties as Library Media Techs to support our students needing a place to do homework, get help with tutoring, and/or access to technology they may not have at home. This also allows for before and after school	\$237,400.00	Yes

Action #	Title	Description	Total Funds	Contributing
		intervention to be housed in the school library so that students are able to receive the targeted support they need in flexible groupings. Additional funds will be expended in the 2022-23 school year to refresh school libraries with additional titles and replacements where needed.		
4.17	MTSS Coordination and Monitoring of UDPs	District personnel will coordinate, revise and update the LJSD district-wide Multi-Tiered System of Support (MTSS) for intervention and remediation with Intervention Coordinators. Additional funds are used to target struggling and/or advanced students. As part of MTSS, our Homeless/Foster Youth Liaison supports the overall monitoring of support for and achievement of our Homeless students in coordination with sites and the counselor at Rancho Starbuck. The Director of Educational Services is the Homeless and Foster Youth Liaison as well as the Attendance Supervisor for the district.	\$226,525.00	Yes
4.18	Assessment System	In order to assess unduplicated pupils and provide appropriate supports, the district needs to invest in a more comprehensive system that will allow for benchmarks, language proficiency assessments and intervention content targeted to student need. A group of teachers were brought together to evaluate the iReady program along with district personnel and Principals. We will be introducing the new system in the 2021-2022 school year, which will necessitate new baseline data for benchmarks as well as training for staff. The data provided from the system will better allow us to assess and monitor our unduplicated students although it will benefit all. The Dashboard will allow for filtering based on high need student groups so that English learners, Foster Youth and low income students can be readily identified in terms of both need and targeted supports. This is funding for a two-year implementation along with some one-time professional development costs.	\$160,000.00	No

Action #	Title	Description	Total Funds	Contributing
4.19	Classified Staff-Custodial Support	Continue to fund additional night custodians beyond base needs to provide daily cleaning of classrooms. This allows for a safe and positive school environment when increasing the demands on existing custodial staff due to before and after school interventions, parent engagement activities, extended professional development, collaboration meetings, and other events funded by supplemental monies.	\$232,018.00	Yes
4.20	Attendance Monitoring	Student absences will be monitored regularly and attendance letters sent out for students with signs of chronic absenteeism. The district will continue with the attendance incentive program to encourage sites to explore unique ways to promote attendance. The Director of Educational Services is also the Attendance Supervisor for the district and will continue to work through the SARB process with principals as needed. Attendance rates are monitored as well as the middle school drop out rate as indicators of overall student engagement.	\$12,000.00	No
4.21	Creative Response to Emotional and Educational Wellness	The Creative Response to Emotional and Educational Wellness or C.R.E.W. has been an overwhelming success. During the pandemic, counseling and psych interns were able to check in and connect with students, provide social emotional lessons during class sessions, and support the overall mental health of students. This has continued during the 2021-22 school year. The counselor and interns monitor the social emotional needs of our UPPs along with a Program Specialist funded through the SELPA and four school psychologists to ensure that both counseling and psychological needs are being met. These services continue to be critical in meeting the social emotional needs of those students still experiencing the effects of trauma from the pandemic. Contacts with Foster Youth, ELs, and low income students (primarily Homeless) are documented weekly to ensure timely supports. In 2021-22, we added services through Care Solace, a third-party vendor who operates as a resource for connecting students, families,	\$771,169.00	Yes

Action #	Title	Description	Total Funds	Contributing
4.22	Nurse and Nursing Assistant	Collaborate with key staff at the county child welfare agency, mental health agency, and other entities providing care and services to foster youth and other UDPs (partial funding for the District Nurse). Offsetting the cost for support to these students along with other local funds has allowed us to hire a nursing assistant who checks in with Foster Youth specifically each week. There is a focus on monitoring the specific needs of our low income families who may need assistance with no or low cost healthcare, screeners, immunizations, or other healthcare supports. An additional LVN position has been created to support the district and adjustments have been made to the Health Tech position for the 2022-23 school year.	\$178,054.00	Yes
		and staff with mental health resources. This includes finding the right support, navigating insurance, and checking in to determine if the issues are being addressed. We continue to hire counseling interns to expand support services to our students with only one counselor for the district. Having interns allows every site to provide much needed services. These services are in addition to the existing partnership with the Gary Center (no cost) and a partnership with Supervisor Hahn's Office for limited counseling support. This was a high priority in feedback on the LCAP, so we have increased the number of interns for the coming year with 5.5 counseling interns and six psych interns. The pay was also slightly increased to remain competitive in attracting the best candidates.		

Goal Analysis [2021-22]

An analysis of how this goal was carried out in the previous year.

A description of any substantive differences in planned actions and actual implementation of these actions.

We have continued to add in layers of our MTSS. Previously, we collected data through CAASPP and benchmarks to look at student groups. We have added the use of other academic checkpoints including iReady as a major focus for this year. For the first time, we have a consistent measure of student growth on benchmarks for every grade level to be able to track progress over the course of the year. We are looking forward to analyzing this data along side CAASPP data once we have scores back from this spring. This will give us a good indication

of how the benchmarks predict proficiency on state standards measured through state testing. As we identify these predictors, it will allow us to better plan for intervention and support for students throughout the year. We have also added a level of social emotional support for our more at risk student groups. Academic and social-emotional check-ins are implemented, and students are experiencing success with school work and relationships. The county office was able to provide nursing support this entire year for our district to support the tremendous workload created by ongoing issues related to Covid 19. That additional support was critical in being able to check in with high risk students while managing the demands of contact tracing and notifications.

An explanation of material differences between Budgeted Expenditures and Estimated Actual Expenditures and/or Planned Percentages of Improved Services and Estimated Actual Percentages of Improved Services.

Once the budget is finalized, any material differences will be analyzed along with any changes in planned percentages for increased and improved services for unduplicated students (Foster Youth, English Learners, and students on Free/Reduced Lunch).

An explanation of how effective the specific actions were in making progress toward the goal.

There is a direct correlation between our action steps and our goal of academic, behavioral, and social-emotional needs of our students. The actions steps have provided support to students with multiple layers of intervention and data shows that students are seeing and feeling more success. Students have improved academically over the prior year although we do not have Dashboard data in terms of color bands. The growth demonstrated on iReady is significant. We are just completing the final reclassification of English Learner students and the sampling of English learner data from iReady shows tremendous growth. Having additional health support from the county during the pandemic allowed for other supports and services for our most needy students to continue. Vision and hearing assessments were conducted for 1429 students with 128 referrals for vision and 3 for hearing along with one dental referral. These required screenings are essential in supporting our socially disadvantaged students that may not otherwise have access to screenings to determine needs. With over 8,000 hours logged for the purposes of contact tracing and other Covid-related services, the addition of support from OCDE was critical in supporting the most basic needs of our students.

A description of any changes made to the planned goal, metrics, desired outcomes, or actions for the coming year that resulted from reflections on prior practice.

Our Dual Immersion program is growing (Goal 4.4). It became evident that the initial program purchased for Spanish language development was not meeting the needs of the program. The Dual Immersion teachers were given a full day of planning time to help define and clarify the overall program now that we are serving students in TK-5th grade. This discussion resulted in the need to examine resources for the program overall. Teachers were brought back together to review curriculum and pilot programs that might better serve their needs. Benchmark Advance was selected to pilot and then Board approved as a new core program for the 2022-23 school year. This will involve additional professional development next year to support teachers with implementation of the new program. We are building access to additional resources such as digital platforms and books that are specific to the Dual Immersion program. There are growing health needs in the district in relation to the number of students with diabetes. An additional LVN is being hired and some adjustments have been made to the Health Tech job description including an increase in hours in order to fill these positions that have been hard to fill. The district continues to hire interns to support the mental health needs of students. With the number of students experiencing the need for support, we have

increased the number of interns to include 5.5 counselors and 6 psychs for the coming year in addition to the one full-time counselor at the intermediate school and four full-time school psychologists..

A report of the Total Estimated Actual Expenditures for last year's actions may be found in the Annual Update Table. A report of the Estimated Actual Percentages of Improved Services for last year's actions may be found in the Contributing Actions Annual Update Table.

Goals and Actions

Goal

Goal #	Description
5	Enrichment and 21st Century Skill Development

An explanation of why the LEA has developed this goal.

With more than 55% of our students coming from low income homes in 2021-2022 (up 15% from the prior year), it continues to be evident that not all students have equal access to opportunities outside of school to experience and develop 21st century skills which often require access to pathways that some families are able to provide and some are not. As a district, Lowell Joint has continued to add programs to support enrichment and talent development without a formalized GATE program. Both staff and parents have provided feedback that we need to develop more opportunities and a more cohesive program while not limiting access to just formally identified GATE students. With this in mind, the district is developing a comprehensive identification system that includes multiple measures and local norms for GATE identification, training all teachers in best practices for working with GATE students to impact instruction within the day, and creating enrichment opportunities that do not require GATE identification for participation. We continue to believe that all students should have access to music and the arts, coding and STEAM, leadership opportunities and outlets to showcase their unique talents and abilities. With the addition of on-going funds for Expanded Learning Opportunities, the district is developing a wide variety of offerings to support both enrichment and 21st century skill development. Harnessing student interest to support development of the whole child through this new program will truly allow for much greater access and participation of students.

Measuring and Reporting Results

Metric	Baseline	Year 1 Outcome	Year 2 Outcome	Year 3 Outcome	Desired Outcome for 2023-24
Completion of GATE Certification	Three staff members have currently completed GATE certification (meeting the requirements outlined by the OCC GATE consortium). There are an additional 30 plus teachers scheduled to	An additional 64 staff members have completed GATE certification this year. There are 30 additional staff scheduled to be certified in the 2022-2023 school year. The 64 teachers who have completed GATE			All teachers within the district will be GATE certified.

Metric	Baseline	Year 1 Outcome	Year 2 Outcome	Year 3 Outcome	Desired Outcome for 2023-24
GATE Assessments and Local Norms	<p>We are in the process of purchasing assessments and developing local norms.</p>	<p>certification have a subscription to Byrdseed.com- a resource to help teachers incorporate GATE standards into their classrooms.</p> <p>The CogAT was chosen to be the assessment to use as the Universal Screener. This assessment was purchased and second-grade teachers were trained to proctor within the classroom. The CogAT was given to all second-grade students throughout the district in the Spring of 2022 with the exception of students whose families decided to opt out of any GATE identification. A team of teachers and staff is being developed in order to develop more specific local norms as the identification process continues. An additional assessment</p>			<p>Appropriate staff will be trained on administering assessments and evaluating criteria for GATE identification using local norms.</p>

Metric	Baseline	Year 1 Outcome	Year 2 Outcome	Year 3 Outcome	Desired Outcome for 2023–24
		for creativity is being identified as part of the multiple measures and will be administered in the fall of 2022.			
TOSA Calendar	Supports in the 2020-2021 school year focused on the elements necessary for distance learning with a heavy emphasis on technology support, software resources, and blended learning models. With the first GATE training this summer, the TOSA will be able to schedule time to support teachers with implementation of strategies within the classroom in the 2021-2022 school year.	During the 2021-2022 school year, TOSA support transitioned back to in-person support. TOSAs were able to schedule time with teachers, students, and parents with an emphasis on early literacy, STEAM integration, technology support, and software resources following hybrid learning. GATE training has continued with in class support offered and executed. The implementation of ViewSonic Boards within classrooms began with district-wide training followed by individual follow through training.			The TOSA's calendar will reflect in-class support of teachers in implementing strategies, facilitation of the identification process with the GATE Advisory Committee, and equal time developing and supporting the STEAM program.
STEAM lab purchases and activity logs	3 of the 5 elementary sites have access to a STEAM lab with	All 5 elementary school STEAM labs are now outfitted with			All sites will have a STEAM lab built out with resources on

Metric	Baseline	Year 1 Outcome	Year 2 Outcome	Year 3 Outcome	Desired Outcome for 2023-24
Professional Development records	varying levels of usage that is not really tracked to determine equal access from all students.	furniture and supplies to provide a positive and enriching environment for students to participate in STEAM activities. A sign-up sheet is in process of development for sites to use during the 2022-2023 school year.			hand for STEAM activities. Teachers will have toured the labs and received professional development on how to integrate the lab into their core curriculum.
STEAM Participation- Students have multiple opportunities to participate in STEAM activities: Within their classrooms, Computer Science club, AP Computer Science and/or Robotics during the school day and as part of after school enrichment.	Activity logs for the elementary STEAM labs reflect some teacher participation in bringing students to the lab for activities (about 20%). Sign in sheets/Attendance show 300 students participated in the Computer Science club, AP Computer Science, and/or Robotics during the 20/21 year.	Now that students are back on campus full time, school sites have resumed the in-person coding and robotics clubs after school or on Saturdays. With the furniture and materials added to STEAM labs, participation in bringing students to the STEAM labs for activities has increased to 30%.			Activity logs will reflect all students having multiple opportunities to access the lab and participate in enrichment activities during the school day in addition to after school enrichment opportunities. Participation in Computer Science club, AP Computer Science and/or Robotics will increase by 5%.

Actions

Action #	Title	Description	Total Funds	Contributing
5.1	Professional Development-GATE Certification	Training teachers in depth and complexity to support critical thinking and high levels of rigor in the classroom benefits all students. As a small district with typically two teachers at a grade level per site, it is important to train all teachers. This ensures that all students will have access to a highly qualified teacher who understands the unique needs of gifted and talented learners and can differentiate instruction accordingly. A portion of the Teacher on Special Assignment who will coordinate trainings and provide coaching support to teachers around implementation of strategies is included here along with the costs for training and resources.	\$108,000.00	No
5.2	GATE Identification	The primary goal of developing comprehensive identification criteria is to ensure that typically under-represented student groups (including English learners, low income, and Foster Youth) are afforded access to GATE services. Measures of leadership and creativity along with a non-verbal assessment will be included along with more traditional measures. Training all teachers in the characteristics of gifted and talented students is to ensure teachers are not just identifying students who are doing well in school. The Universal Screener was administered to all 2nd graders this year, and the data is being evaluated to determine further assessments as part of the multiple measures.	\$15,000.00	Yes
5.3	STEAM Enrichment	Continue to expand access to STEAM programs at the elementary level above offerings within the classroom as part of traditional science. This becomes increasingly important as we develop College and Career Pathways for our elementary sites to feed into Rancho Starbuck programs such as the AP Computer Science course or the Conservatory of the Fine Arts (CoFA). This is especially true for our unduplicated pupils who lack access to technology and STEAM experiences outside of the school system. In evaluating STEAM labs at each of the sites, there are some costs for resources such as equipment and tables at a few sites with some additional costs for materials at all sites. This also includes an ongoing partnership with	\$169,919.00	No

Action #	Title	Description	Total Funds	Contributing
		Fullerton Joint Union High School District to develop pathways that feed into high school programs. Included here is a portion of the cost for the Teacher on Special Assignment who is developing the STEAM program along with overseeing GATE. Many of the new offerings through the Expanded Learning Opportunities funding will support STEAM enrichment: coding, robotics and art for example.		
5.4	Technology Integration-21st Century Skills	Continue to fund a Teacher on Special Assignment (TOSA) to assist staff in the integration of technology with the content standards to provide access to specialized support programs and resources for differentiating instruction for UPPs. The TOSA also provides support for illuminate and training teachers on reports for data analysis to monitor progress for English learners, students from low income families, and Foster Youth. This often means supporting parents of these students as well who need training in navigating digital resources for use in the home. With the completion of the Chromebook initiative, we are developing training for interactive displays that will allow for more student interaction to support the use of visuals as well as anchoring academic vocabulary within the room through the use of sentence stems, concept maps, and Thinking Maps for example in support of our English learners. Includes stipend for work outside contracted days.	\$255,306.00	Yes

Goal Analysis [2021-22]

An analysis of how this goal was carried out in the previous year.

A description of any substantive differences in planned actions and actual implementation of these actions.

The original plan for teacher training in 2021-2022 included 30 teachers to be trained; however, we were able to train 64 teachers in the first year. About half of all teachers are now GATE certified in the district, which is a substantial increase in the number of teachers originally anticipated.

An explanation of material differences between Budgeted Expenditures and Estimated Actual Expenditures and/or Planned Percentages of Improved Services and Estimated Actual Percentages of Improved Services.

Once the budget is finalized, any material differences will be analyzed along with any changes in planned percentages for increased and improved services for unduplicated students (Foster Youth, English Learners, and students on Free/Reduced Lunch).

An explanation of how effective the specific actions were in making progress toward the goal.

Developing STEAM labs with materials and furniture made it possible for ALL of our students (including UPPs) to have access to enrichment opportunities during the school day as well as before and after school. We have begun robotics with Spheros, which will continue to grow in the coming year. For GATE training, as mentioned above, the increase in the number of teachers we were able to train in year 1 has allowed us to certify more than half of our teaching staff. This means that teachers are better equipped to serve the needs of our gifted learners in addition to applying elements of Depth and Complexity with all learners to support critical thinking. Byrdseed.com, an online resource with lessons, ideas, and professional development resources, has been provided to all teachers who have completed certification, which has allowed them to explore meaningful ways to incorporate strategies for gifted learners throughout the day. The universal screener for 2nd grade was completed, so now we are reviewing actual students for formal identification in order to track progress and provide targeted services.

A description of any changes made to the planned goal, metrics, desired outcomes, or actions for the coming year that resulted from reflections on prior practice.

No specific changes to the action items, but a number of additional actions will be included in the Expanded Learning Opportunities plan in the coming year. Those will ultimately be referenced here as they meet the need for enrichment opportunities for students. The description for the STEAM/GATE TOSA was modified to broaden supports in other core areas. The identified actions will still be carried out by the TOSA, but the name has been changed to support MTSS in general.

A report of the Total Estimated Actual Expenditures for last year's actions may be found in the Annual Update Table. A report of the Estimated Actual Percentages of Improved Services for last year's actions may be found in the Contributing Actions Annual Update Table.

Increased or Improved Services for Foster Youth, English Learners, and Low-Income Students [2022-23]

Projected LCFF Supplemental and/or Concentration Grants	Projected Additional LCFF Concentration Grant (15 percent)
2775305	0

Required Percentage to Increase or Improve Services for the LCAP Year

Projected Percentage to Increase or Improve Services for the Coming School Year	LCFF Carryover — Percentage	LCFF Carryover — Dollar	Total Percentage to Increase or Improve Services for the Coming School Year
10.00%	0.00%	\$0.00	10.00%

The Budgeted Expenditures for Actions identified as Contributing may be found in the Contributing Actions Table.

Required Descriptions

For each action being provided to an entire school, or across the entire school district or county office of education (COE), an explanation of (1) how the needs of foster youth, English learners, and low-income students were considered first, and (2) how these actions are effective in meeting the goals for these students.

The Actions and Services best support our UDPs because they are integrated services as part of a Multi-Tiered System of Support. With 1,274 students counted as low income and as few as 17 Foster Youth, 80 Homeless and 210 English learners across six schools, it is not in the best interest of these students to isolate supports outside of MTSS. We realize this allows access for other students while maximizing resources although the services are principally directed toward one or more unduplicated pupil group.

English Learners

A unique need for our English learner population includes the communication with and opportunities for parents in their primary language, which we have built into the LCAP. In the California Department of Education's Improving Education for English Learners: Research-Based Approaches (2010), there are 8 guidelines in Chapter 4 for "Effective English Literacy Instruction for English Learners". Guideline 8 relates to honoring the home language. Increased communication and opportunities for both parents and students in their primary language support this research. Guidelines 1 and 5 are related to essential components of literacy and oral language development, which are addressed through both first, best instruction in the classroom and intervention with Lingual Learning materials through small group instruction during intervention as part of the overall MTSS program. Guideline 2, "effective instruction for English learners is similar to effective instruction for native speakers" and Guideline 7, "well prepared teachers" are addressed in the research chart for all students. This is also true for Guideline 3 (instruction adjusted to meet their needs) and 6 (instruction is differentiated) as part of both the overall MTSS program with the specific focus on Universal Design for Learning to meet the needs of all students-including English learners and first, best instruction

practices. The comprehensive and multidimensional approach recommended in Guideline 4 will be enhanced this year through an expansion of MTSS services with a focus on Universal Design for Learning. This focus will allow teachers to improve classroom instruction in literacy for English learners. With the addition of an Early Literacy TOSA, we are also able to provide much needed professional development around language acquisition through Project GLAD training and follow up. This is principally directed at meeting the needs of our English learners, however, all students in need of language development support will benefit.

English Learners

Goal 4, Action 1: 75% Professional Development on Thinking Maps and Write from the Beginning which focuses on nonlinguistic representations of thinking with scaffolded supports for writing to support English learners.

Goal 4, Action 2: 100% Professional Development on CCSS and ELD standards including specific strategies for working with ELs in both Integrated and Designated ELD (Project GLAD).

Goal 4, Action 3: 100% Progress Monitoring and Support of English learners (Bilingual Aides) including communication with and outreach to parents.

Goal 4, Action 4: 100% Dual Immersion program which supports the development of truly biliterate students.

Goal 4, Action 5: 75% ELD and Spanish electives at Rancho. This is in addition to an ELA class with Designated ELD and Integrated ELD within other subject area courses. We have also added a Spanish elective to support primary language fluency.

Monitor language progress with iReady

Multi-Tiered System of Support

English learners, Foster Youth, and Low-income students

Universal Design for Learning (UDL) is an educational framework based on research in the learning sciences, including cognitive neuroscience, that guides the development of flexible learning environments that can accommodate individual learning differences. Working within this framework allows teachers to plan for and use the most effective strategies for students with different learning needs, which is especially important for our English learners in literacy. In the context of our Multi-Tiered System of Support, in addition to the unique academic needs of our students, we are addressing the social-emotional and behavioral needs, which include supports for our Foster Youth, low income, Homeless, and English learners as appropriate. Prior to the 2015-16 school year, there were no interventions offered within the school day. Much of the work from 2015 to 2019 has been in creating the structures and supports to provide intervention within the school day. Additional training and resources for teachers to be able to analyze data for placement into intervention and then provide instruction for intervention has also been a priority. This is in line with the research to provide comprehensive intervention to students, especially with increased access during the day, while the existing before and after school offerings to provide extended learning opportunities have been expanded. Hattie's research also supports the need for decreasing disruptive behaviors (ES=.53), the climate of the classroom (ES=.52), and staff and student relationships (ES=.72). Counseling and psych services along with EMHRS support have been identified as actions to develop safe, school climates conducive to learning. RtI, the intervention component embedded within our MTSS program, has an effect size

of 1.07 in Hattie's research. For that reason, it has been and continues to be a priority of the district to develop the necessary supports and systems of a comprehensive, MTSS model to ensure the needs of all our students are being met with a primary focus of supports for our UDPs through the use of Supplemental funds.

Goal 2, Action 1: 100% Early Literacy TOSA-The majority of our English learners are in TK-2nd grade. This position was created in the 2020-2021 year to begin addressing issues of school readiness as two local preschools closed. As we began working with First Five, Orange County and the Early Developmental Index data on school readiness, it became clear that we needed a person to coordinate efforts in building those strong early literacy skills to set the stage for academic success.

Goal 2, Action 4: 100% Preschool-Again, with the closure of two local preschools and an increased awareness of the deficits some of our incoming students were facing, the district has begun the process to open a preschool in service of our those students most impacted by the lack of access to school readiness opportunities.

Goal 2, Action 5: 80% Transitional Kindergarten-There was only a single TK classroom prior to LCFF funding and the program has continued to grow as the importance of building foundational skills for Kindergarten preparedness has become a priority.

Goal 4, Action 5:100% ELD, Reading Intervention, and Spanish-This section allows for targeted support to the students needing ELD and/or Reading intervention to be successful in their English course. There is also one section of Spanish offered as an elective that allows for a cognitive break in the day for our English learners while building additional literacy in their primary language. This is directed at UDPs with the potential for other students to participate in the course should space allow.

Goal 4, Act on 6: 100% Before and After School Intervention-This is principally directed at meeting the academic needs of our UDPs. Students are monitored for participation and using the library allows access to devices and the internet for those who may not have access in the home.

Goal 4, Action 7: 100% Intervention Coordinators-This represents the stipends paid to one teacher per site for the purposes of organizing intervention, tracking student data, and monitoring English learners and our most struggling students. These stipends would not be available without the use of supplemental dollars.

Goal 4, Action 8: 100% Intervention Support During the Day- This allows for the targeted support of our UDPs in small group intervention throughout the day with qualified personnel. Students are flexibly grouped and moved regularly based on need as part of the overall MTSS.

Goal 4, Action 11: 100% Math Intervention-Rancho Starbuck-This section allows for targeted support to the students needing math intervention to be successful in their math course. This is directed at UDPs with the potential for other students to participate in the course should space allow.

Goal 4, Action 12: 100% Illuminate-While the district uses Aeries as it's student information system, Illuminate was purchased to allow teachers to access data in more meaningful ways to monitor the progress of both student groups and individual students. ELPAC and other language proficiency data is housed in Illuminate as are results from benchmarks and IABs to provide a comprehensive view of student progress. This is especially needed to monitor our UDPs in targeted supports for intervention.

Goal 4, Action 13:100% As referenced in the explanation for Goal 4, Action 5, the Reading Intervention section at Rancho is targeted support for students needing extra assistance for success in their English Language Arts course. This is directed at UDPs with the potential for other students to participate in the course should space allow.

Goal 4, Action 14: 50% Coordination of Services-This reflects a portion of the salaries of one certificated and one classified staff for coordinating services directly related to the reporting, monitoring, and development of services for our UDPs. There is one additional fiscal person who was added to manage the increase in POs, payroll, substitute costs for trainings, extra hours for summer trainings, and so forth.

Goal 4, Action 16:100% Learning Hubs-Libraries- This reflects the cost for an additional 10 hours per site of the Library Media Tech to keep the library open and provide a space for our UDPs to receive homework help, tutoring, and access to internet.

Goal 4, Action 17: 80% MTSS Coordination and Monitoring of UDPs-A portion of the salary of the Director of Educational Services who monitors and supports all Foster Youth, Homeless, and English Learners within the district. This position did not exist prior to the 2015-16 school year and was developed to support the Educational Services department in meeting all requirements connected with servicing our UDPs.

Goal 4, Action 18: 50% Assessment System-This is a new system explored in the 2020-2021 school year and purchased for the whole district in 2021-2022. Without access to state assessment data, it became clear that the varied systems at the sites did not easily allow for the aggregation of data at the district level. This made it very difficult to monitor progress on standards for our various student groups since our benchmarks in grades 3-8 were from the state system (IABs). Other data was not consistent across the district although used to monitor at the site level. So the use of iReady will allow for better measurement of progress for our UDPs across the district while also providing intervention and supports based on individual student need.

Goal 4, Action 19: 100% Classified Staff-Custodial Support-This reflects only the portion of salary identified to address the demands on custodial staff related to those items increasing or improving services for our UDPs. For example, keeping the library open an additional 10 hours shifts the cleaning and sanitizing of the space onto the next custodial shift. Parent trainings and other night time events targeting our UDPs also increase the need for additional custodial support.

Goal 4, Action 21: 100% Creative Response to Emotional and Educational Wellness-With only one counselor and 3 school psychologists to support the district. the ongoing need for additional services was a common thread from all stakeholders. The CREW program was designed to meet this need by partnering with local universities to hire interns. Anywhere from 8-12 interns are hired each year to focus on our UDPs through weekly check-ins and small group sessions as needed. The prioritized list of contacts for the interns each week is Foster Youth and Homeless with additional students seen as space allows.

Goal 4, Action 23: 20% Nurse and Nursing Assistant- Only a small percentage of the Nurse's salary is included in supplemental funds to ensure that coordination with community partners to support families with low or no cost healthcare, screeners, and referrals can be done in a timely manner. The Nursing Assistant is not included in supplemental dollars; however, this position is responsible for checking in with Foster Youth each week for support with any potential needs for these students. This allows us to improve our services to Foster Youth without additional cost to the supplemental budget.

Parents and Community Engagement

Hattie's research shows an effect size of .51 for parent involvement in learning. This is echoed in the research from Proven Interventions to Increase Student Achievement of Poor and Minority Students where engaging families, parents, and the community is vital to the success of students. Supporting parents is also identified by the National Education Association (NEA) as researched-based, best practices in Strategies for Closing the Achievement Gap.

Goal 1, Action 12: 100% School Site Council and DELAC-There is no additional cost for these committees since they are facilitated by existing staff; however, the training of our parents is vitally important to ensuring that we have the parent voice reflected in our Goals and Actions designed to meet the needs of our UDPs. Low income and English learner families often struggle with connecting to the school and availing themselves of available resources. The SSC is a requirement under Title I (monies provided to meet the needs of low income families); however, we have all schools complete a School Plan for Student Achievement.

Goal 1, Action 13: 20% Parent Teacher Associations (PTA)-There is no cost to this item other than the time of an existing employee. It is important in building relationships between the PTA and staff that we support the focus of increasing the number of parents of our UDPs with involvement in the PTA. This allows for representation in the decision-making process as well as a stronger community of stakeholders.

Goal 2, Action 1: 100% Early Literacy TOSA- The Early Literacy TOSA is directly responsible for supporting the language development of our English learners through training teachers and modeling in the classroom, connecting with community and parent organizations to facilitate the distribution of resources for our UDPs, and managing the deliverables identified in the First Five grant to support school readiness and foundational skills for those students without access to other preschool programs.

Goal 2, Action 3: 100% Early Literacy-Community Engagement-The development of a newsletter in addition to other resources to connect with parents on a regular basis to offer support and resources in developing foundational skills in kids ages 0-5. This is specifically designed to connect with our community to ensure that resources are available to support those families without the means to develop these skills in their children unassisted.

Goal 2, Action 4: 100% Learning Link Program-As part of the Early Literacy TOSA's responsibilities, we are opening a new Learning Link to connect with families of kids ages 0-5. Parents are trained to work with their child through activities that help develop school readiness skills for student success upon entering Transitional Kindergarten or Kindergarten. This is specifically targeting our low income families that do not have access to preschool options.

Access to Technology, Student Engagement, Rigorous Curriculum, College and Career Readiness (21st century skills)
English learners, Foster Youth, and Low-income students

Again pulled from Hattie's research, Problem Based Learning (ES=.65), Goals (ES=.56), and High Expectations (ES=.43) are all effective strategies in engaging students at high levels and providing access to career paths that might otherwise be out of reach for our UDPs. This same finding is echoed in Proven Interventions to Increase Student Achievement of Poor and Minority Students, which talks about having high expectations and providing a rigorous curriculum and also in Strategies for Closing the Achievement Gap. The actions and services outlined below are designed to provide both access and opportunities principally directed at our UDPs to meet this need.

Goal 5, Action 2: 40% GATE Identification-We have spent over a year developing an identification system that will target traditionally underrepresented student groups, which are our UDPs (Foster Youth, low income, and English Learners). The district has not had a formal identification system in well over 10 years. Identifying an appropriate non-linguistic assessment for English learners, a measure of creativity and leadership along with traditional assessments using local norms has been a key first step. Another is moving toward the training of all teachers within the district so that the qualities of gifted and talented students are readily recognized regardless of formal identification. This has the added benefit of increasing the level of rigor and critical thinking for all students regardless of gate identification.

Goal 5, Action 3: 40% STEAM Enrichment-Many of our low income families do not have access to experiences outside the school day related to STEAM. Providing access to coding, engineering activities, robotics, music and the arts, gaming, and things like AP Computer Science, Audio Engineering, and Construction Math at the intermediate level are critically important in developing pathways for students to college and career. Exposing younger students to a wide variety of offerings to encourage exploration with an eye toward deeper levels of understanding with connections to possible careers by intermediate school is hugely important in breaking the cycle of poverty for our low income families.

Goal 5, Action 4: 40% Technology Integration-21st Century Skills-Similar to the STEAM enrichment, students today would be hard pressed to compete at high levels in the workplace without the ability to integrate the use of technology in meaningful ways. This includes exposure to technology tools for productivity (email, presentation programs, documents, spreadsheets, and so forth) as well as tools for learning (3-D printers, green screens, video production, coding, virtual reality, Viewsonic boards, Ipevo cameras, etc.) While some families are able to provide access to these types of tools, they are frequently non-existent in our low income households. The tools and activities designed to use the tools support all students, but they are principally directed at our low income students who would not otherwise have access to these types of experiences.

A description of how services for foster youth, English learners, and low-income students are being increased or improved by the percentage required.

The Lowell Joint School District's (LJSD) Unduplicated Pupil Percentage projected for 2021-22 is 8.2%. The actions and services developed in the LJSD LCAP will be principally directed toward unduplicated student groups through Supplemental funding for the 2021-22 LCAP including the following continuing actions and new actions described in more detail above:

Targeted Supports for English Learners Only

Goal 1, Action 12: DELAC

Goal 4, Action 1: Professional Development on Thinking Maps and Write from the Beginning which focuses on nonlinguistic representations of thinking with scaffolded supports for writing to support English learners.

Goal 4, Action 2: Professional Development on CCSS and ELD standards including specific strategies for working with ELs in both Integrated and Designated ELD (Project GLAD).

Goal 4, Action 3: Progress Monitoring and Support of English learners (Bilingual Aides)

Goal 4, Action 4: Dual Immersion

Goal 4, Action 5: ELD and Spanish electives at Rancho.

Targeted Supports for Low Income Only

Goal 1, Action 12: School Site Council

Targeted Supports for English learners, Foster Youth, and Low-income students

Goal 2, Action 1: Early Literacy TOSA

Goal 2, Action 4: Preschool

Goal 2, Action 5: Transitional Kindergarten

Goal 4, Action 5: ELD, Reading Intervention, and Spanish

Goal 4, Action 6: Before and After School Intervention

Goal 4, Action 7: Intervention Coordinators

Goal 4, Action 8: Intervention Support During the Day

Goal 4, Action 11: Math Intervention-Rancho Starbuck

Goal 4, Action 12: Illuminate

Goal 4, Action 13: Reading Intervention at Rancho

Goal 4, Action 14: Coordination of Services

Goal 4, Action 16: Learning Hubs-Libraries

Goal 4, Action 17: MTSS Coordination and Monitoring of UDPs

Goal 4, Action 18: Assessment System

Goal 4, Action 19: Classified Staff-Custodial Support

Goal 4, Action 21: Creative Response to Emotional and Educational Wellness

Goal 4, Action 23: Nurse and Nursing Assistant

Goal 5, Action 3: STEAM Enrichment

Our Foster Youth, Homeless (a portion of our low-income families) and English learners are all monitored on a weekly basis by various support personnel, which allows us to increase and improve services based on the individual needs of these students under the umbrella of our MTSS. These support positions would not be available without the supplemental dollars designated for our unduplicated pupils. Goals for Early Literacy and 21st Century Skills and Enrichment were designed with an eye toward predominantly supporting the 56% of students who qualify as low income and our English learners who would not otherwise have access to these types of programs to support career paths and language development outside of the general classroom. These added layers to our overall MTSS represent additions to supplemental expenditures for the 2022-2023 school year along with ongoing programs developed with supplemental funding in the prior LCAP.

A description of the plan for how the additional concentration grant add-on funding identified above will be used to increase the number of staff providing direct services to students at schools that have a high concentration (above 55 percent) of foster youth, English learners, and low-income students, as applicable.

We did not receive an additional concentration grant add-on.

Staff-to-student ratios by type of school and concentration of unduplicated students	Schools with a student concentration of 55 percent or less	Schools with a student concentration of greater than 55 percent
Staff-to-student ratio of classified staff providing direct services to students		
Staff-to-student ratio of certificated staff providing direct services to students		

2022-23 Total Expenditures Table

Totals		LCFF Funds	Other State Funds	Local Funds	Federal Funds	Total Funds	Total Personnel	Total Non-personnel
Totals		\$26,382,366.00	\$4,487,149.00	\$196,207.00	\$2,074,836.00	\$33,140,558.00	\$31,163,834.00	\$1,976,724.00
Goal	Action #	Action Title	Student Group(s)	LCFF Funds	Other State Funds	Local Funds	Federal Funds	Total Funds
1	1.1	Certificated Staffing-Teachers	All	\$14,772,239.00	\$1,821,856.00		\$397,388.00	\$16,991,483.00
1	1.2	Certificated Staffing-Administration and other Support Staff	All	\$1,713,857.00	\$1,102,997.00		\$355,490.00	\$3,172,344.00
1	1.3	Classified Staffing-Technology Department	All	\$465,378.00				\$465,378.00
1	1.4	Classified Staffing-Custodial, Maintenance, and Grounds	All	\$1,773,857.00				\$1,773,857.00
1	1.5	Basic Utilities	All	\$830,328.00				\$830,328.00
1	1.6	Instructional Materials-Textbooks and Software	All	\$313,567.00				\$313,567.00
1	1.7	Site Technology Allocation	All	\$45,000.00				\$45,000.00
1	1.8	Instructional Supplies-Per Pupil Site Allocation	All	\$271,180.00				\$271,180.00
1	1.9	Maintenance of Chromebooks	All					\$0.00
1	1.10	Classified Staffing-Data Systems Analyst	All	\$51,916.00				\$51,916.00
1	1.11	Single Plan for Student Achievement (SPSA)	All	\$5,000.00				\$5,000.00
1	1.12	School Site Council and DELAC	All					\$0.00

Goal	Action #	Action Title	Student Group(s)	LCFF Funds	Other State Funds	Local Funds	Federal Funds	Total Funds
1	1.13	Parent Teacher Associations (PTA)	All					\$0.00
1	1.14	Family Engagement	All	\$34,647.00				\$34,647.00
1	1.15	Classified Staff-Administration and other Support	All	\$2,552,183.00	\$26,609.00	\$81,807.00	\$35,404.00	\$2,696,003.00
2	2.1	Early Literacy Teacher on Special Assignment (TOSA)	English Learners Foster Youth Low Income	\$10,000.00		\$53,398.00	\$72,508.00	\$135,906.00
2	2.2	Early Literacy Committee	All			\$1,000.00		\$1,000.00
2	2.3	Early Literacy-Community Engagement	All			\$30,002.00		\$30,002.00
2	2.4	Early Literacy-Preschool Program and Learning Link	English Learners Low Income	\$1,000.00	\$25,000.00	\$30,000.00		\$56,000.00
2	2.5	Transitional Kindergarten	English Learners Foster Youth Low Income	\$632,359.00				\$632,359.00
3	3.1	Facilities Master Plan	All					\$0.00
3	3.2	FIT Reports	All					\$0.00
3	3.3	Measure LL-Bond	All					\$0.00
4	4.1	Professional Development (District-wide)	English Learners Foster Youth Low Income	\$420,000.00				\$420,000.00
4	4.2	Professional Development- English Learners	English Learners	\$20,000.00			\$15,000.00	\$35,000.00
4	4.3	Progress Monitoring and Support of English Learners	English Learners	\$136,491.00	\$54,356.00		\$43,122.00	\$233,969.00
4	4.4	Dual Immersion Program	English Learners	\$300,216.00	\$75,566.00		\$79,807.00	\$455,589.00
4	4.5	ELD, Reading Intervention, and Spanish Elective at Rancho	English Learners Low Income	\$53,584.00				\$53,584.00

Goal	Action #	Action Title	Student Group(s)	LCFF Funds	Other State Funds	Local Funds	Federal Funds	Total Funds
4	4.6	Before and After School Intervention	English Learners Foster Youth Low Income	\$80,000.00				\$80,000.00
4	4.7	Intervention Coordinators	English Learners Foster Youth Low Income	\$9,092.00	\$9,092.00		\$3,637.00	\$21,821.00
4	4.8	Intervention Support During the Day	All				\$110,000.00	\$110,000.00
4	4.9	Teacher Planning/Choir Teacher	All	\$98,437.00				\$98,437.00
4	4.10	Classified Staff-Instructional Assistants & Special Ed Support Aides	Students with Disabilities	\$130,494.00	\$307,698.00		\$700,952.00	\$1,139,144.00
4	4.11	Math Intervention-Rancho Starbuck	English Learners Foster Youth Low Income	\$37,535.00				\$37,535.00
4	4.12	Illuminate	English Learners Foster Youth Low Income	\$25,000.00				\$25,000.00
4	4.13	Reading Intervention-Rancho Starbuck	English Learners Foster Youth Low Income	\$40,000.00				\$40,000.00
4	4.14	Coordination of Services	English Learners Foster Youth Low Income	\$243,769.00				\$243,769.00
4	4.15	ABA Class and Program Specialist Position	All		\$275,349.00			\$275,349.00
4	4.16	Learning Hubs-Libraries	English Learners Foster Youth Low Income	\$86,731.00	\$150,669.00			\$237,400.00
4	4.17	MTSS Coordination and Monitoring of UDPs	English Learners Foster Youth Low Income	\$185,220.00			\$41,305.00	\$226,525.00
4	4.18	Assessment System	All		\$160,000.00			\$160,000.00
4	4.19	Classified Staff-Custodial Support	English Learners Foster Youth Low Income	\$232,018.00				\$232,018.00

Goal	Action #	Action Title	Student Group(s)	LCFF Funds	Other State Funds	Local Funds	Federal Funds	Total Funds
4	4.20	Attendance Monitoring	All	\$12,000.00				\$12,000.00
4	4.21	Creative Response to Emotional and Educational Wellness	English Learners Foster Youth Low Income	\$545,129.00	\$226,040.00			\$771,169.00
4	4.22	Nurse and Nursing Assistant	Foster Youth Low Income	\$18,833.00	\$63,917.00		\$95,304.00	\$178,054.00
5	5.1	Professional Development-GATE Certification	All	\$65,000.00	\$43,000.00			\$108,000.00
5	5.2	GATE Identification	English Learners Foster Youth Low Income	\$15,000.00				\$15,000.00
5	5.3	STEAM Enrichment	All		\$45,000.00		\$124,919.00	\$169,919.00
5	5.4	Technology Integration-21st Century Skills	English Learners Foster Youth Low Income	\$155,306.00	\$100,000.00			\$255,306.00

2022-23 Contributing Actions Table

1. Projected LCFF Base Grant	2. Projected LCFF Supplemental and/or Concentration Grants	3. Projected Percentage Increase or Improve Services for the Coming School Year (2 divided by 1)	LCFF Carryover — Percentage from Prior Year	Total Percentage Increase or Improve Services for the Coming School Year (3 + Carryover %)	4. Total Planned Contributing Expenditures (LCFF Funds)	5. Total Planned Percentage of Improved Services (%)	Planned Percentage to Increase or Improve Services for the Coming School Year (4 divided by 1, plus 5)	Totals by Type	Total LCFF Funds
27742766	2775305	10.00%	0.00%	10.00%	\$3,247,283.00	0.00%	11.70 %	Total:	\$3,247,283.00
								LEA-wide Total:	\$2,815,948.00
								Limited Total:	\$0.00
								Schoolwide Total:	\$431,335.00

Goal	Action #	Action Title	Contributing to Increased or Improved Services?	Scope	Unduplicated Student Group(s)	Location	Planned Expenditures for Contributing Actions (LCFF Funds)	Planned Percentage of Improved Services (%)
2	2.1	Early Literacy Teacher on Special Assignment (TOSA)	Yes	LEA-wide	English Learners Foster Youth Low Income	All Schools	\$10,000.00	
2	2.4	Early Literacy-Preschool Program and Learning Link	Yes	LEA-wide	English Learners Low Income	Specific Schools: Jordan Ages 0-5	\$1,000.00	
2	2.5	Transitional Kindergarten	Yes	LEA-wide	English Learners Foster Youth Low Income	Specific Schools: Elementary sites Transitional Kindergarten	\$632,359.00	
4	4.1	Professional Development (District-wide)	Yes	LEA-wide	English Learners Foster Youth Low Income	All Schools	\$420,000.00	
4	4.2	Professional Development-English Learners	Yes	LEA-wide	English Learners	All Schools	\$20,000.00	
4	4.3	Progress Monitoring and Support of English Learners	Yes	LEA-wide	English Learners	All Schools	\$136,491.00	

Goal	Action #	Action Title	Contributing to Increased or Improved Services?	Scope	Unduplicated Student Group(s)	Location	Planned Expenditures for Contributing Actions (LCFF Funds)	Planned Percentage of Improved Services (%)
4	4.4	Dual Immersion Program	Yes	Schoolwide	English Learners	Specific Schools: Jordan Elementary TK-3rd grade	\$300,216.00	
4	4.5	ELD, Reading Intervention, and Spanish Elective at Rancho	Yes	Schoolwide	English Learners Low Income	Specific Schools: Rancho 7th and 8th grade	\$53,584.00	
4	4.6	Before and After School Intervention	Yes	LEA-wide	English Learners Foster Youth Low Income	All Schools	\$80,000.00	
4	4.7	Intervention Coordinators	Yes	LEA-wide	English Learners Foster Youth Low Income	All Schools	\$9,092.00	
4	4.11	Math Intervention-Rancho Starbuck	Yes	Schoolwide	English Learners Foster Youth Low Income	Specific Schools: Rancho Starbuck 7th and 8th	\$37,535.00	
4	4.12	Illuminate	Yes	LEA-wide	English Learners Foster Youth Low Income	All Schools	\$25,000.00	
4	4.13	Reading Intervention-Rancho Starbuck	Yes	Schoolwide	English Learners Foster Youth Low Income	Specific Schools: Rancho Starbuck 7th and 8th	\$40,000.00	
4	4.14	Coordination of Services	Yes	LEA-wide	English Learners Foster Youth Low Income	All Schools	\$243,769.00	
4	4.16	Learning Hubs-Libraries	Yes	LEA-wide	English Learners Foster Youth Low Income	All Schools	\$86,731.00	
4	4.17	MTSS Coordination and Monitoring of UDRs	Yes	LEA-wide	English Learners Foster Youth Low Income	All Schools	\$185,220.00	
4	4.19	Classified Staff-Custodial Support	Yes	LEA-wide	English Learners Foster Youth Low Income	All Schools	\$232,018.00	
4	4.21	Creative Response to Emotional and Educational Wellness	Yes	LEA-wide	English Learners Foster Youth Low Income	All Schools	\$545,129.00	

Goal	Action #	Action Title	Contributing to Increased or Improved Services?	Scope	Unduplicated Student Group(s)	Location	Planned Expenditures for Contributing Actions (LCFF Funds)	Planned Percentage of Improved Services (%)
4	4.22	Nurse and Nursing Assistant	Yes	LEA-wide	Foster Youth Low Income	All Schools	\$18,833.00	
5	5.2	GATE Identification	Yes	LEA-wide	English Learners Foster Youth Low Income	All Schools	\$15,000.00	
5	5.4	Technology Integration-21st Century Skills	Yes	LEA-wide	English Learners Foster Youth Low Income	All Schools	\$155,306.00	

2021-22 Annual Update Table

Totals		Last Year's Total Planned Expenditures (Total Funds)	Total Estimated Expenditures (Total Funds)		
Totals		\$31,273,651.00	\$31,819,775.00		
Last Year's Goal #	Last Year's Action #	Prior Action/Service Title	Contributed to Increased or Improved Services?	Last Year's Planned Expenditures (Total Funds)	Estimated Actual Expenditures (Input Total Funds)
1	1.1	Certificated Staffing-Teachers	No	\$15,608,363.00	\$15,363,783.00
1	1.2	Certificated Staffing-Administration and other Support Staff	No	\$2,695,938.00	\$2,274,708.00
1	1.3	Classified Staffing-Technology Department	No	\$407,997.00	\$403,115.00
1	1.4	Classified Staffing-Custodial, Maintenance, and Grounds	No	\$1,773,857.00	\$2,086,613.00
1	1.5	Basic Utilities	No	\$830,328.00	\$874,817.00
1	1.6	Instructional Materials-Textbooks and Software	No	\$313,567.00	\$1,451,994.00
1	1.7	Site Technology Allocation	No	\$45,000.00	\$21,973.00
1	1.8	Instructional Supplies-Per Pupil Site Allocation	No	\$271,180.00	\$283,970.00
1	1.9	Maintenance of Chromebooks	No	\$0.00	\$241,313.00
1	1.10	Classified Staffing-Data Systems Analyst	No	\$51,916.00	\$50,805.00

Last Year's Goal #	Last Year's Action #	Prior Action/Service Title	Contributed to Increased or Improved Services?	Last Year's Planned Expenditures (Total Funds)	Estimated Actual Expenditures (Input Total Funds)
1	1.11	Single Plan for Student Achievement (SPSA)	No	\$5,000.00	\$0.00
1	1.12	School Site Council and DELAC	No	\$0.00	\$0.00
1	1.13	Parent Teacher Associations (PTA)	No	\$0.00	\$0.00
1	1.14	Family Engagement	No	\$34,647.00	\$0.00
1	1.15	Classified Staff-Administration and other Support	No	\$2,696,003.00	\$3,081,330.00
2	2.1	Early Literacy Teacher on Special Assignment (TOSA)	Yes	\$135,906.00	\$128,551.00
2	2.2	Early Literacy Committee	No	\$1,000.00	\$0.00
2	2.3	Early Literacy-Community Engagement	No	\$30,002.00	\$0.00
2	2.4	Early Literacy-Preschool Program and Learning Link	Yes	\$56,000.00	\$31,814.00
2	2.5	Transitional Kindergarten	Yes	\$632,359.00	\$579,041.00
3	3.1	Facilities Master Plan	No	\$0.00	\$0.00
3	3.2	FIT Reports	No	\$0.00	\$0.00
3	3.3	Measure LL-Bond	No	\$0.00	\$0.00

Last Year's Goal #	Last Year's Action #	Prior Action/Service Title	Contributed to Increased or Improved Services?	Last Year's Planned Expenditures (Total Funds)	Estimated Actual Expenditures (Input Total Funds)
4	4.1	Professional Development (District-wide)	Yes	\$420,000.00	\$30,184.00
4	4.2	Professional Development- English Learners	Yes	\$35,000.00	\$0.00
4	4.3	Progress Monitoring and Support of English Learners	Yes	\$233,969.00	\$196,309.00
4	4.4	Dual Immersion Program	Yes	\$455,589.00	\$432,933.00
4	4.5	ELD, Reading Intervention, and Spanish Elective at Rancho	Yes	\$53,584.00	\$62,554.00
4	4.6	Before and After School Intervention	Yes	\$80,000.00	\$59,839.00
4	4.7	Intervention Coordinators	Yes	\$21,821.00	\$18,260.00
4	4.8	Intervention Support During the Day	No	\$160,000.00	\$0.00
4	4.9	Teacher Planning/Choir Teacher	No	\$98,437.00	\$96,906.00
4	4.10	Classified Staff-Instructional Assistants & Special Ed Support Aides	No	\$1,139,144.00	\$1,341,913.00
4	4.11	Math Intervention-Rancho Starbuck	Yes	\$37,535.00	\$43,117.00
4	4.12	Illuminate	Yes	\$25,000.00	\$21,621.00

Last Year's Goal #	Last Year's Action #	Prior Action/Service Title	Contributed to Increased or Improved Services?	Last Year's Planned Expenditures (Total Funds)	Estimated Actual Expenditures (Input Total Funds)
4	4.13	Reading Intervention-Rancho Starbuck	Yes	\$40,000.00	\$0.00
4	4.14	Coordination of Services	Yes	\$243,769.00	\$227,228.00
4	4.15	ABA Class and Program Specialist Position	No	\$275,349.00	\$271,909.00
4	4.16	Learning Hubs-Libraries	Yes	\$237,400.00	\$241,377.00
4	4.17	MTSS Coordination and Monitoring of UDPs	Yes	\$226,525.00	\$222,837.00
4	4.18	Assessment System	No	\$160,000.00	\$0.00
4	4.19	Classified Staff-Custodial Support	Yes	\$232,018.00	\$230,237.00
4	4.20	Attendance Monitoring	No	\$12,000.00	\$0.00
4	4.21	Creative Response to Emotional and Educational Wellness	Yes	\$771,169.00	\$878,851.00
4	4.22	Nurse and Nursing Assistant	Yes	\$178,054.00	\$287,598.00
5	5.1	Professional Development-GATE Certification	No	\$108,000.00	\$5,515.00
5	5.2	GATE Identification	Yes	\$15,000.00	\$0.00
5	5.3	STEAM Enrichment	No	\$169,919.00	\$123,505.00

Last Year's Goal #	Last Year's Action #	Prior Action/Service Title	Contributed to Increased or Improved Services?	Last Year's Planned Expenditures (Total Funds)	Estimated Actual Expenditures (Input Total Funds)
5	5.4	Technology Integration-21st Century Skills	Yes	\$255,306.00	\$153,255.00

2021-22 Contributing Actions Annual Update Table

6. Estimated LCFE Supplemental and/or Concentration Grants (Input Dollar Amount)	4. Total Planned Contributing Expenditures (LCFF Funds)	7. Total Estimated Expenditures for Contributing Actions (LCFF Funds)	Difference Between Planned and Estimated Expenditures for Contributing Actions (Subtract 7 from 4)	5. Total Planned Percentage of Improved Services (%)	8. Total Estimated Percentage of Improved Services (%)	Difference Between Planned and Estimated Percentage of Improved Services (Subtract 5 from 8)	
	\$3,247,283.00	\$2,186,996.00	\$1,060,287.00	0.00%	0.00%	0.00%	
Last Year's Goal #	Last Year's Action #	Prior Action/Service Title	Contributing to Increased or Improved Services?	Last Year's Planned Expenditures for Contributing Actions (LCFF Funds)	Estimated Actual Expenditures for Contributing Actions (Input LCFF Funds)	Planned Percentage of Improved Services	Estimated Actual Percentage of Improved Services (Input Percentage)
2	2.1	Early Literacy Teacher on Special Assignment (TOSA)	Yes	\$10,000.00	\$0.00		
2	2.4	Early Literacy-Preschool Program and Learning Link	Yes	\$1,000.00	\$0.00		
2	2.5	Transitional Kindergarten	Yes	\$632,359.00	\$579,041.00		
4	4.1	Professional Development (District-wide)	Yes	\$420,000.00	\$0.00		
4	4.2	Professional Development-English Learners	Yes	\$20,000.00	\$0.00		
4	4.3	Progress Monitoring and Support of English Learners	Yes	\$136,491.00	\$146,435.00		
4	4.4	Dual Immersion Program	Yes	\$300,216.00	\$195,125.00		
4	4.5	ELD, Reading Intervention, and Spanish Elective at Rancho	Yes	\$53,584.00	\$62,554.00		
4	4.6	Before and After School Intervention	Yes	\$80,000.00	\$59,830.00		
4	4.7	Intervention Coordinators	Yes	\$9,092.00	\$9,130.00		
4	4.11	Math Intervention-Rancho Starbuck	Yes	\$37,535.00	\$43,117.00		

Last Year's Goal #	Last Year's Action #	Prior Action/Service Title	Contributing to Increased or Improved Services?	Last Year's Planned Expenditures for Contributing Actions (LCFF Funds)	Estimated Actual Expenditures for Contributing Actions (Input LCFF Funds)	Planned Percentage of Improved Services	Estimated Actual Percentage of Improved Services (Input Percentage)
4	4.12	Illuminate	Yes	\$25,000.00	\$0.00		
4	4.13	Reading Intervention-Rancho Starbuck	Yes	\$40,000.00	\$0.00		
4	4.14	Coordination of Services	Yes	\$243,769.00	\$155,583.00		
4	4.16	Learning Hubs-Libraries	Yes	\$86,731.00	\$84,005		
4	4.17	MTSS Coordination and Monitoring of UDPs	Yes	\$185,220.00	\$163,329.00		
4	4.19	Classified Staff-Custodial Support	Yes	\$232,018.00	\$230,237.00		
4	4.21	Creative Response to Emotional and Educational Wellness	Yes	\$545,129.00	\$305,355		
4	4.22	Nurse and Nursing Assistant	Yes	\$18,833.00	\$0.00		
5	5.2	GATE Identification	Yes	\$15,000.00	\$0.00		
5	5.4	Technology Integration-21st Century Skills	Yes	\$155,306.00	\$153,255.00		

2021-22 LCFF Carryover Table

9. Estimated Actual LCFF Base Grant (Input Dollar Amount)	6. Estimated Actual LCFF Supplemental and/or Concentration Grants	LCFF Carryover — Percentage (Percentage from Prior Year)	10. Total Percentage to Increase or Improve Services for the Current School Year (6 divided by 9 + Carryover %)	7. Total Estimated Actual Expenditures for Contributing Actions (LCFF Funds)	8. Total Estimated Actual Percentage of Improved Services (%)	11. Estimated Actual Percentage of Increased or Improved Services (7 divided by 9, plus 8)	12. LCFF Carryover — Dollar Amount (Subtract 11 from 10 and multiply by 9)	13. LCFF Carryover — Percentage (12 divided by 9)
			0.00%	\$2,186,996.00	0.00%	0.00%	\$0.00	0.00%

Instructions

Plan Summary

Engaging Educational Partners

Goals and Actions

Increased or Improved Services for Foster Youth, English Learners, and Low-Income Students

For additional questions or technical assistance related to the completion of the Local Control and Accountability Plan (LCAP) template, please contact the local county office of education (COE), or the California Department of Education's (CDE's) Local Agency Systems Support Office, by phone at 916-319-0809 or by email at lcff@cde.ca.gov.

Introduction and Instructions

The Local Control Funding Formula (LCFF) requires local educational agencies (LEAs) to engage their local educational partners in an annual planning process to evaluate their progress within eight state priority areas encompassing all statutory metrics (COEs have 10 state priorities). LEAs document the results of this planning process in the LCAP using the template adopted by the State Board of Education.

The LCAP development process serves three distinct, but related functions:

- **Comprehensive Strategic Planning:** The process of developing and annually updating the LCAP supports comprehensive strategic planning (California Education Code [EC] Section 52064[e][1]). Strategic planning that is comprehensive connects budgetary decisions to teaching and learning performance data. LEAs should continually evaluate the hard choices they make about the use of limited resources to meet student and community needs to ensure opportunities and outcomes are improved for all students.
- **Meaningful Engagement of Educational Partners:** The LCAP development process should result in an LCAP that reflects decisions made through meaningful engagement (EC Section 52064[e][1]). Local educational partners possess valuable perspectives and insights about an LEA's programs and services. Effective strategic planning will incorporate these perspectives and insights in order to identify potential goals and actions to be included in the LCAP.
- **Accountability and Compliance:** The LCAP serves an important accountability function because aspects of the LCAP template require LEAs to show that they have complied with various requirements specified in the LCFF statutes and regulations, most notably:
 - Demonstrating that LEAs are increasing or improving services for foster youth, English learners, and low-income students in proportion to the amount of additional funding those students generate under LCFF (EC Section 52064[b][4-6]).
 - Establishing goals, supported by actions and related expenditures, that address the statutory priority areas and statutory metrics (EC sections 52064[b][1] and [2]).
 - Annually reviewing and updating the LCAP to reflect progress toward the goals (EC Section 52064[b][7]).

The LCAP template, like each LEA's final adopted LCAP, is a document, not a process. LEAs must use the template to memorialize the outcome of their LCAP development process, which should: (a) reflect comprehensive strategic planning (b) through meaningful engagement with educational partners that (c) meets legal requirements, as reflected in the final adopted LCAP. The sections included within the LCAP template do not and cannot reflect the full development process, just as the LCAP template itself is not intended as a tool for engaging educational partners.

If a county superintendent of schools has jurisdiction over a single school district, the county board of education and the governing board of the school district may adopt and file for review and approval a single LCAP consistent with the requirements in EC sections 52060, 52062, 52066, 52068, and 52070. The LCAP must clearly articulate to which entity's budget (school district or county superintendent of schools) all budgeted and actual expenditures are aligned.

The revised LCAP template for the 2021–22, 2022–23, and 2023–24 school years reflects statutory changes made through Assembly Bill 1840 (Committee on Budget), Chapter 243, Statutes of 2018. These statutory changes enhance transparency regarding expenditures on actions included in the LCAP, including actions that contribute to meeting the requirement to increase or improve services for foster youth, English learners, and low-income students, and to streamline the information presented within the LCAP to make adopted LCAPs more accessible for educational partners and the public.

At its most basic, the adopted LCAP should attempt to distill not just what the LEA is doing for students in transitional kindergarten through grade twelve (TK–12), but also allow educational partners to understand why, and whether those strategies are leading to improved opportunities and outcomes for students. LEAs are strongly encouraged to use language and a level of detail in their adopted LCAPs intended to be meaningful and accessible for the LEA's diverse educational partners and the broader public.

In developing and finalizing the LCAP for adoption, LEAs are encouraged to keep the following overarching frame at the forefront of the strategic planning and educational partner engagement functions:

Given present performance across the state priorities and on indicators in the California School Dashboard (Dashboard), how is the LEA using its budgetary resources to respond to TK–12 student and community needs, and address any performance gaps, including by meeting its obligation to increase or improve services for foster youth, English learners, and low-income students?

LEAs are encouraged to focus on a set of metrics and actions that the LEA believes, based on input gathered from educational partners, research, and experience, will have the biggest impact on behalf of its TK–12 students.

These instructions address the requirements for each section of the LCAP, but may include information about effective practices when developing the LCAP and completing the LCAP itself. Additionally, information is included at the beginning of each section emphasizing the purpose that each section serves.

Plan Summary

Purpose

A well-developed Plan Summary section provides a meaningful context for the LCAP. This section provides information about an LEA's community as well as relevant information about student needs and performance. In order to provide a meaningful context for the rest of the LCAP, the content of this section should be clearly and meaningfully related to the content included in the subsequent sections of the LCAP.

Requirements and Instructions

General Information – Briefly describe the LEA, its schools, and its students in grades TK–12, as applicable to the LEA. For example, information about an LEA in terms of geography, enrollment, or employment, the number and size of specific schools, recent community challenges, and other such information as an LEA wishes to include can enable a reader to more fully understand an LEA's LCAP.

Reflections: Successes – Based on a review of performance on the state indicators and local performance indicators included in the Dashboard, progress toward LCAP goals, local self-assessment tools, input from educational partners, and any other information, what progress is the LEA most proud of and how does the LEA plan to maintain or build upon that success? This may include identifying specific examples of how past increases or improvements in services for foster youth, English learners, and low-income students have led to improved performance for these students.

Reflections: Identified Need – Referring to the Dashboard, identify: (a) any state indicator for which overall performance was in the “Red” or “Orange” performance category or any local indicator where the LEA received a “Not Met” or “Not Met for Two or More Years” rating AND (b) any state indicator for which performance for any student group was two or more performance levels below the “all student” performance. What steps is the LEA planning to take to address these areas of low performance and performance gaps? An LEA that is required to include a goal to address one or more consistently low-performing student groups or low-performing schools must identify that it is required to include this goal and must also identify the applicable student group(s) and/or school(s). Other needs may be identified using locally collected data including data collected to inform the self-reflection tools and reporting local indicators on the Dashboard.

LCAP Highlights – Identify and briefly summarize the key features of this year's LCAP.

Comprehensive Support and Improvement – An LEA with a school or schools identified for comprehensive support and improvement (CSI) under the Every Student Succeeds Act must respond to the following prompts:

- **Schools Identified:** Identify the schools within the LEA that have been identified for CSI.
- **Support for Identified Schools:** Describe how the LEA has or will support the identified schools in developing CSI plans that included a school-level needs assessment, evidence-based interventions, and the identification of any resource inequities to be addressed through the implementation of the CSI plan.
- **Monitoring and Evaluating Effectiveness:** Describe how the LEA will monitor and evaluate the implementation and effectiveness of the CSI plan to support student and school improvement.

Engaging Educational Partners

Purpose

Significant and purposeful engagement of parents, students, educators, and other educational partners, including those representing the student groups identified by LCFF, is critical to the development of the LCAP and the budget process. Consistent with statute, such engagement should support comprehensive strategic planning, accountability, and improvement across the state priorities and locally identified priorities (EC Section 52064[e][1]). Engagement of educational partners is an ongoing, annual process.

This section is designed to reflect how the engagement of educational partners influenced the decisions reflected in the adopted LCAP. The goal is to allow educational partners that participated in the LCAP development process and the broader public understand how the LEA engaged educational partners and the impact of that engagement. LEAs are encouraged to keep this goal in the forefront when completing this section.

Statute and regulations specify the educational partners that school districts and COEs must consult when developing the LCAP: teachers, principals, administrators, other school personnel, local bargaining units of the LEA, parents, and students. Before adopting the LCAP, school districts and COEs must share it with the Parent Advisory Committee and, if applicable, to its English Learner Parent Advisory Committee. The superintendent is required by statute to respond in writing to the comments received from these committees. School districts and COEs must also consult with the special education local plan area administrator(s) when developing the LCAP.

Statute requires charter schools to consult with teachers, principals, administrators, other school personnel, parents, and students in developing the LCAP. The LCAP should also be shared with, and LEAs should request input from, schoolsite-level advisory groups, as applicable (e.g., schoolsite councils, English Learner Advisory Councils, student advisory groups, etc.), to facilitate alignment between schoolsite and district-level goals and actions.

Information and resources that support effective engagement, define student consultation, and provide the requirements for advisory group composition, can be found under Resources on the following web page of the CDE's website: <https://www.cde.ca.gov/re/lc/>.

Requirements and Instructions

Below is an excerpt from the 2018–19 *Guide for Annual Audits of K–12 Local Education Agencies and State Compliance Reporting*, which is provided to highlight the legal requirements for engagement of educational partners in the LCAP development process:

Local Control and Accountability Plan:

For county offices of education and school districts only, verify the LEA:

- a) Presented the local control and accountability plan to the parent advisory committee in accordance with Education Code section 52062(a)(1) or 52068(a)(1), as appropriate.
- b) If applicable, presented the local control and accountability plan to the English learner parent advisory committee, in accordance with Education Code section 52062(a)(2) or 52068(a)(2), as appropriate.

- c) Notified members of the public of the opportunity to submit comments regarding specific actions and expenditures proposed to be included in the local control and accountability plan in accordance with Education Code section 52062(a)(3) or 52068(a)(3), as appropriate.
- d) Held at least one public hearing in accordance with Education Code section 52062(b)(1) or 52068(b)(1), as appropriate.
- e) Adopted the local control and accountability plan in a public meeting in accordance with Education Code section 52062(b)(2) or 52068(b)(2), as appropriate.

Prompt 1: “A summary of the process used to engage educational partners and how this engagement was considered before finalizing the LCAP.”

Describe the engagement process used by the LEA to involve educational partners in the development of the LCAP, including, at a minimum, describing how the LEA met its obligation to consult with all statutorily required educational partners as applicable to the type of LEA. A sufficient response to this prompt must include general information about the timeline of the process and meetings or other engagement strategies with educational partners. A response may also include information about an LEA’s philosophical approach to engaging its educational partners.

Prompt 2: “A summary of the feedback provided by specific educational partners.”

Describe and summarize the feedback provided by specific educational partners. A sufficient response to this prompt will indicate ideas, trends, or inputs that emerged from an analysis of the feedback received from educational partners.

Prompt 3: “A description of the aspects of the LCAP that were influenced by specific input from educational partners.”

A sufficient response to this prompt will provide educational partners and the public with clear, specific information about how the engagement process influenced the development of the LCAP. The response must describe aspects of the LCAP that were influenced by or developed in response to the educational partner feedback described in response to Prompt 2. This may include a description of how the LEA prioritized requests of educational partners within the context of the budgetary resources available or otherwise prioritized areas of focus within the LCAP. For the purposes of this prompt, “aspects” of an LCAP that may have been influenced by educational partner input can include, but are not necessarily limited to:

- Inclusion of a goal or decision to pursue a Focus Goal (as described below)
- Inclusion of metrics other than the statutorily required metrics
- Determination of the desired outcome on one or more metrics
- Inclusion of performance by one or more student groups in the Measuring and Reporting Results subsection
- Inclusion of action(s) or a group of actions
- Elimination of action(s) or group of actions
- Changes to the level of proposed expenditures for one or more actions

- Inclusion of action(s) as contributing to increased or improved services for unduplicated services
- Determination of effectiveness of the specific actions to achieve the goal
- Determination of material differences in expenditures
- Determination of changes made to a goal for the ensuing LCAP year based on the annual update process
- Determination of challenges or successes in the implementation of actions

Goals and Actions

Purpose

Well-developed goals will clearly communicate to educational partners what the LEA plans to accomplish, what the LEA plans to do in order to accomplish the goal, and how the LEA will know when it has accomplished the goal. A goal statement, associated metrics and expected outcomes, and the actions included in the goal should be in alignment. The explanation for why the LEA included a goal is an opportunity for LEAs to clearly communicate to educational partners and the public why, among the various strengths and areas for improvement highlighted by performance data and strategies and actions that could be pursued, the LEA decided to pursue this goal, and the related metrics, expected outcomes, actions, and expenditures.

A well-developed goal can be focused on the performance relative to a metric or metrics for all students, a specific student group(s), narrowing performance gaps, or implementing programs or strategies expected to impact outcomes. LEAs should assess the performance of their student groups when developing goals and the related actions to achieve such goals.

Requirements and Instructions

LEAs should prioritize the goals, specific actions, and related expenditures included within the LCAP within one or more state priorities. LEAs should consider performance on the state and local indicators, including their locally collected and reported data for the local indicators that are included in the Dashboard in determining whether and how to prioritize its goals within the LCAP.

In order to support prioritization of goals, the LCAP template provides LEAs with the option of developing three different kinds of goals:

- **Focus Goal:** A Focus Goal is relatively more concentrated in scope and may focus on a fewer number of metrics to measure improvement. A Focus Goal statement will be time bound and make clear how the goal is to be measured.
- **Broad Goal:** A Broad Goal is relatively less concentrated in its scope and may focus on improving performance across a wide range of metrics.
- **Maintenance of Progress Goal:** A Maintenance of Progress Goal includes actions that may be ongoing without significant changes and allows an LEA to track performance on any metrics not addressed in the other goals of the LCAP.

At a minimum, the LCAP must address all LCFF priorities and associated metrics.

Focus Goal(s)

Goal Description: The description provided for a Focus Goal must be specific, measurable, and time bound. An LEA develops a Focus Goal to address areas of need that may require or benefit from a more specific and data intensive approach. The Focus Goal can explicitly reference the metric(s) by which achievement of the goal will be measured and the time frame according to which the LEA expects to achieve the goal.

Explanation of why the LEA has developed this goal: Explain why the LEA has chosen to prioritize this goal. An explanation must be based on Dashboard data or other locally collected data. LEAs must describe how the LEA identified this goal for focused attention, including relevant consultation with educational partners. LEAs are encouraged to promote transparency and understanding around the decision to pursue a focus goal.

Broad Goal

Goal Description: Describe what the LEA plans to achieve through the actions included in the goal. The description of a broad goal will be clearly aligned with the expected measurable outcomes included for the goal. The goal description organizes the actions and expected outcomes in a cohesive and consistent manner. A goal description is specific enough to be measurable in either quantitative or qualitative terms. A broad goal is not as specific as a focus goal. While it is specific enough to be measurable, there are many different metrics for measuring progress toward the goal.

Explanation of why the LEA has developed this goal: Explain why the LEA developed this goal and how the actions and metrics grouped together will help achieve the goal.

Maintenance of Progress Goal

Goal Description: Describe how the LEA intends to maintain the progress made in the LCFF State Priorities not addressed by the other goals in the LCAP. Use this type of goal to address the state priorities and applicable metrics not addressed within the other goals in the LCAP. The state priorities and metrics to be addressed in this section are those for which the LEA, in consultation with educational partners, has determined to maintain actions and monitor progress while focusing implementation efforts on the actions covered by other goals in the LCAP.

Explanation of why the LEA has developed this goal: Explain how the actions will sustain the progress exemplified by the related metrics.

Required Goals

In general, LEAs have flexibility in determining what goals to include in the LCAP and what those goals will address; however, beginning with the development of the 2022–23 LCAP, LEAs that meet certain criteria are required to include a specific goal in their LCAP.

Consistently low-performing student group(s) criteria: An LEA is eligible for Differentiated Assistance for three or more consecutive years based on the performance of the same student group or groups in the Dashboard. A list of the LEAs required to include a goal in the LCAP based on student group performance, and the student group(s) that lead to identification, may be found on the CDE’s Local Control Funding Formula web page at <https://www.cde.ca.gov/fg/aa/lc/>.

- **Consistently low-performing student group(s) goal requirement:** An LEA meeting the consistently low-performing student group(s) criteria must include a goal in its LCAP focused on improving the performance of the student group or groups that led to the LEA’s eligibility for Differentiated

Assistance. This goal must include metrics, outcomes, actions, and expenditures specific to addressing the needs of, and improving outcomes for, this student group or groups. An LEA required to address multiple student groups is not required to have a goal to address each student group; however, each student group must be specifically addressed in the goal. This requirement may not be met by combining this required goal with another goal.

- **Goal Description:** Describe the outcomes the LEA plans to achieve to address the needs of, and improve outcomes for, the student group or groups that led to the LEA's eligibility for Differentiated Assistance.
- **Explanation of why the LEA has developed this goal:** Explain why the LEA is required to develop this goal, including identifying the student group(s) that lead to the LEA being required to develop this goal, how the actions and associated metrics included in this goal differ from previous efforts to improve outcomes for the student group(s), and why the LEA believes the actions, metrics, and expenditures included in this goal will help achieve the outcomes identified in the goal description.

Low-performing school(s) criteria: The following criteria only applies to a school district or COE with two or more schools; it does not apply to a single-school district. A school district or COE has one or more schools that, for two consecutive years, received the two lowest performance levels on all but one of the state indicators for which the school(s) receive performance levels in the Dashboard and the performance of the "All Students" student group for the LEA is at least one performance level higher in all of those indicators. A list of the LEAs required to include a goal in the LCAP based on school performance, and the school(s) that lead to identification, may be found on the CDE's Local Control Funding Formula web page at <https://www.cde.ca.gov/fg/aa/lc/>.

- **Low-performing school(s) goal requirement:** A school district or COE meeting the low-performing school(s) criteria must include a goal in its LCAP focusing on addressing the disparities in performance between the school(s) and the LEA as a whole. This goal must include metrics, outcomes, actions, and expenditures specific to addressing the needs of, and improving outcomes for, the students enrolled at the low-performing school or schools. An LEA required to address multiple schools is not required to have a goal to address each school; however, each school must be specifically addressed in the goal. This requirement may not be met by combining this goal with another goal.
- **Goal Description:** Describe what outcomes the LEA plans to achieve to address the disparities in performance between the students enrolled at the low-performing school(s) and the students enrolled at the LEA as a whole.
- **Explanation of why the LEA has developed this goal:** Explain why the LEA is required to develop this goal, including identifying the school(s) that lead to the LEA being required to develop this goal; how the actions and associated metrics included in this goal differ from previous efforts to improve outcomes for the school(s); and why the LEA believes the actions, metrics, and expenditures included in this goal will help achieve the outcomes for students enrolled at the low-performing school or schools identified in the goal description.

Measuring and Reporting Results:

For each LCAP year, identify the metric(s) that the LEA will use to track progress toward the expected outcomes. LEAs are encouraged to identify metrics for specific student groups, as appropriate, including expected outcomes that would reflect narrowing of any existing performance gaps.

Include in the baseline column the most recent data associated with this metric available at the time of adoption of the LCAP for the first year of the three-year plan. LEAs may use data as reported on the 2019 Dashboard for the baseline of a metric only if that data represents the most recent available (e.g., high school graduation rate).

Using the most recent data available may involve reviewing data the LEA is preparing for submission to the California Longitudinal Pupil Achievement Data System (CALPADS) or data that the LEA has recently submitted to CALPADS. Because final 2020–21 outcomes on some metrics may not be computable at the time the 2021–24 LCAP is adopted (e.g., graduation rate, suspension rate), the most recent data available may include a point in time calculation taken each year on the same date for comparability purposes.

The baseline data shall remain unchanged throughout the three-year LCAP.

Complete the table as follows:

- **Metric:** Indicate how progress is being measured using a metric.
- **Baseline:** Enter the baseline when completing the LCAP for 2021–22. As described above, the baseline is the most recent data associated with a metric. Indicate the school year to which the data applies, consistent with the instructions above.
- **Year 1 Outcome:** When completing the LCAP for 2022–23, enter the most recent data available. Indicate the school year to which the data applies, consistent with the instructions above.
- **Year 2 Outcome:** When completing the LCAP for 2023–24, enter the most recent data available. Indicate the school year to which the data applies, consistent with the instructions above.
- **Year 3 Outcome:** When completing the LCAP for 2024–25, enter the most recent data available. Indicate the school year to which the data applies, consistent with the instructions above. The 2024–25 LCAP will be the first year in the next three-year cycle. Completing this column will be part of the Annual Update for that year.
- **Desired Outcome for 2023–24:** When completing the first year of the LCAP, enter the desired outcome for the relevant metric the LEA expects to achieve by the end of the 2023–24 LCAP year.

Timeline for completing the “**Measuring and Reporting Results**” part of the Goal.

Metric	Baseline	Year 1 Outcome	Year 2 Outcome	Year 3 Outcome	Desired Outcome for Year 3 (2023–24)
Enter information in this box when completing the LCAP for 2021–22 .	Enter information in this box when completing the LCAP for 2021–22 .	Enter information in this box when completing the LCAP for 2022–23 . Leave blank until then.	Enter information in this box when completing the LCAP for 2023–24 . Leave blank until then.	Enter information in this box when completing the LCAP for 2024–25 . Leave blank until then.	Enter information in this box when completing the LCAP for 2021–22 or when adding a new metric.

The metrics may be quantitative or qualitative; but at minimum, an LEA’s LCAP must include goals that are measured using all of the applicable metrics for the related state priorities, in each LCAP year as applicable to the type of LEA. To the extent a state priority does not specify one or more metrics (e.g., implementation of state academic content and performance standards), the LEA must identify a metric to use within the LCAP. For these state priorities, LEAs are encouraged to use metrics based on or reported through the relevant self-reflection tool for local indicators within the Dashboard.

Actions: Enter the action number. Provide a short title for the action. This title will also appear in the action tables. Provide a description of the action. Enter the total amount of expenditures associated with this action. Budgeted expenditures from specific fund sources will be provided in the summary tables. Indicate whether the action contributes to meeting the increase or improved services requirement as described in the Increased or Improved Services section using a “Y” for Yes or an “N” for No. (**Note:** for each such action offered on an LEA-wide or schoolwide basis, the LEA will need to provide additional information in the Increased or Improved Summary Section to address the requirements in *California Code of Regulations*, Title 5 [5 CCR] Section 15496(b) in the Increased or Improved Services Section of the LCAP).

Actions for English Learners: School districts, COEs, and charter schools that have a numerically significant English learner student subgroup must include specific actions in the LCAP related to, at a minimum, the language acquisition programs, as defined in EC Section 306, provided to students and professional development activities specific to English learners.

Actions for Foster Youth: School districts, COEs, and charter schools that have a numerically significant Foster Youth student subgroup are encouraged to include specific actions in the LCAP designed to meet needs specific to Foster Youth students.

Goal Analysis:

Enter the LCAP Year.

Using actual annual measurable outcome data, including data from the Dashboard, analyze whether the planned actions were effective in achieving the goal. Respond to the prompts as instructed.

- Describe the overall implementation of the actions to achieve the articulated goal. Include a discussion of relevant challenges and successes experienced with the implementation process. This must include any instance where the LEA did not implement a planned action or implemented a planned action in a manner that differs substantively from how it was described in the adopted LCAP.
- Explain material differences between Budgeted Expenditures and Estimated Actual Expenditures and between the Planned Percentages of Improved Services and Estimated Actual Percentages of Improved Services, as applicable. Minor variances in expenditures or percentages do not need to be addressed, and a dollar-for-dollar accounting is not required.
- Describe the effectiveness of the specific actions to achieve the articulated goal as measured by the LEA. In some cases, not all actions in a goal will be intended to improve performance on all of the metrics associated with the goal. When responding to this prompt, LEAs may assess the effectiveness of a single action or group of actions within the goal in the context of performance on a single metric or group of specific metrics within the goal that are applicable to the action(s). Grouping actions with metrics will allow for more robust analysis of whether the strategy the LEA is using to impact a specified set of metrics is working and increase transparency for educational partners. LEAs are encouraged to use such an approach when goals include multiple actions and metrics that are not closely associated.
- Describe any changes made to this goal, expected outcomes, metrics, or actions to achieve this goal as a result of this analysis and analysis of the data provided in the Dashboard or other local data, as applicable.

Increased or Improved Services for Foster Youth, English Learners, and Low-Income Students

Purpose

A well-written Increased or Improved Services section provides educational partners with a comprehensive description, within a single dedicated section, of how an LEA plans to increase or improve services for its unduplicated students in grades TK–12 as compared to all students in grades TK–12, as applicable, and how LEA-wide or schoolwide actions identified for this purpose meet regulatory requirements. Descriptions provided should include sufficient detail yet be sufficiently succinct to promote a broader understanding of educational partners to facilitate their ability to provide input. An LEA's description in this section must align with the actions included in the Goals and Actions section as contributing.

Requirements and Instructions

Projected LCFF Supplemental and/or Concentration Grants: Specify the amount of LCFF supplemental and concentration grant funds the LEA estimates it will receive in the coming year based on the number and concentration of low income, foster youth, and English learner students.

Projected Additional LCFF Concentration Grant (15 percent): Specify the amount of additional LCFF concentration grant add-on funding, as described in EC Section 42238.02, that the LEA estimates it will receive in the coming year.

Projected Percentage to Increase or Improve Services for the Coming School Year: Specify the estimated percentage by which services for unduplicated pupils must be increased or improved as compared to the services provided to all students in the LCAP year as calculated pursuant to 5 CCR Section 15496(a)(7).

LCFF Carryover — Percentage: Specify the LCFF Carryover — Percentage identified in the LCFF Carryover Table. If a carryover percentage is not identified in the LCFF Carryover Table, specify a percentage of zero (0.00%).

LCFF Carryover — Dollar: Specify the LCFF Carryover — Dollar amount identified in the LCFF Carryover Table. If a carryover amount is not identified in the LCFF Carryover Table, specify an amount of zero (\$0).

Total Percentage to Increase or Improve Services for the Coming School Year: Add the Projected Percentage to Increase or Improve Services for the Coming School Year and the Proportional LCFF Required Carryover Percentage and specify the percentage. This is the LEAs percentage by which services for unduplicated pupils must be increased or improved as compared to the services provided to all students in the LCAP year, as calculated pursuant to 5 CCR Section 15496(a)(7).

Required Descriptions:

For each action being provided to an entire school, or across the entire school district or COE, an explanation of (1) how the needs of foster youth, English learners, and low-income students were considered first, and (2) how these actions are effective in meeting the goals for these students.

For each action included in the Goals and Actions section as contributing to the increased or improved services requirement for unduplicated pupils and provided on an LEA-wide or schoolwide basis, the LEA must include an explanation consistent with 5 CCR Section 15496(b). For any such actions continued into the 2021–24 LCAP from the 2017–2020 LCAP, the LEA must determine whether or not the action was effective as expected, and this determination must reflect evidence of outcome data or actual implementation to date.

Principally Directed and Effective: An LEA demonstrates how an action is principally directed towards and effective in meeting the LEA's goals for unduplicated students when the LEA explains how:

- It considers the needs, conditions, or circumstances of its unduplicated pupils;
- The action, or aspect(s) of the action (including, for example, its design, content, methods, or location), is based on these considerations; and
- The action is intended to help achieve an expected measurable outcome of the associated goal.

As such, the response provided in this section may rely on a needs assessment of unduplicated students.

Conclusory statements that a service will help achieve an expected outcome for the goal, without an explicit connection or further explanation as to how, are not sufficient. Further, simply stating that an LEA has a high enrollment percentage of a specific student group or groups does not meet the increase or improve services standard because enrolling students is not the same as serving students.

For example, if an LEA determines that low-income students have a significantly lower attendance rate than the attendance rate for all students, it might justify LEA-wide or schoolwide actions to address this area of need in the following way:

After assessing the needs, conditions, and circumstances of our low-income students, we learned that the attendance rate of our low-income students is 7 percent lower than the attendance rate for all students. (Needs, Conditions, Circumstances [Principally Directed])

In order to address this condition of our low-income students, we will develop and implement a new attendance program that is designed to address some of the major causes of absenteeism, including lack of reliable transportation and food, as well as a school climate that does not emphasize the importance of attendance. Goal N, Actions X, Y, and Z provide additional transportation and nutritional resources as well as a districtwide educational campaign on the benefits of high attendance rates. (Contributing Action[s])

These actions are being provided on an LEA-wide basis and we expect/hope that all students with less than a 100 percent attendance rate will benefit. However, because of the significantly lower attendance rate of low-income students, and because the actions meet needs most associated with the chronic stresses and experiences of a socio-economically disadvantaged status, we expect that the attendance rate for our low-income students will increase significantly more than the average attendance rate of all other students. (Measurable Outcomes [Effective In])

COEs and Charter Schools: Describe how actions included as contributing to meeting the increased or improved services requirement on an LEA-wide basis are principally directed to and effective in meeting its goals for unduplicated pupils in the state and any local priorities as described above. In the case of COEs and charter schools, schoolwide and LEA-wide are considered to be synonymous.

For School Districts Only:

Actions Provided on an LEA-Wide Basis:

Unduplicated Percentage > 55 percent: For school districts with an unduplicated pupil percentage of 55 percent or more, describe how these actions are principally directed to and effective in meeting its goals for unduplicated pupils in the state and any local priorities as described above.

Unduplicated Percentage < 55 percent: For school districts with an unduplicated pupil percentage of less than 55 percent, describe how these actions are principally directed to and effective in meeting its goals for unduplicated pupils in the state and any local priorities. Also describe how the actions are the **most effective use of the funds** to meet these goals for its unduplicated pupils. Provide the basis for this determination, including any alternatives considered, supporting research, experience, or educational theory.

Actions Provided on a Schoolwide Basis:

School Districts must identify in the description those actions being funded and provided on a schoolwide basis, and include the required description supporting the use of the funds on a schoolwide basis.

For schools with 40 percent or more enrollment of unduplicated pupils: Describe how these actions are principally directed to and effective in meeting its goals for its unduplicated pupils in the state and any local priorities.

For school districts expending funds on a schoolwide basis at a school with less than 40 percent enrollment of unduplicated pupils: Describe how these actions are principally directed to and how the actions are the most effective use of the funds to meet its goals for foster youth, English learners, and low-income students in the state and any local priorities.

A description of how services for foster youth, English learners, and low-income students are being increased or improved by the percentage required.

Consistent with the requirements of 5 CCR Section 15496, describe how services provided for unduplicated pupils are increased or improved by at least the percentage calculated as compared to the services provided for all students in the LCAP year. To improve services means to grow services in quality and to increase services means to grow services in quantity. Services are increased or improved by those actions in the LCAP that are included in the Goals and Actions section as contributing to the increased or improved services requirement, whether they are provided on an LEA-wide or schoolwide basis or provided on a limited basis to unduplicated students. A limited action is an action that only serves foster youth, English learners, and/or low-income students. This description must address how these action(s) are expected to result in the required proportional increase or improvement in services for unduplicated pupils as compared to the services the LEA provides to all students for the relevant LCAP year.

For any action contributing to meeting the increased or improved services requirement that is associated with a Planned Percentage of Improved Services in the Contributing Summary Table rather than an expenditure of LCFF funds, describe the methodology that was used to determine the contribution of the action towards the proportional percentage. See the instructions for determining the Planned Percentage of Improved Services for information on calculating the Percentage of Improved Services.

A description of the plan for how the additional concentration grant add-on funding identified above will be used to increase the number of staff providing direct services to students at schools that have a high concentration (above 55 percent) of foster youth, English learners, and low-income students, as applicable.

An LEA that receives the additional concentration grant add-on described in EC Section 42238.02 is required to demonstrate how it is using these funds to increase the number of staff who provide direct services to students at schools with an enrollment of unduplicated students that is greater than 55 percent as compared to the number of staff who provide direct services to students at schools with an enrollment of unduplicated students that is equal to or less than 55 percent. The staff who provide direct services to students must be certificated staff and/or classified staff employed by the LEA; classified staff includes custodial staff.

Provide the following descriptions, as applicable to the LEA:

An LEA that does not receive a concentration grant or the concentration grant add-on must indicate that a response to this prompt is not applicable.

Identify the goal and action numbers of the actions in the LCAP that the LEA is implementing to meet the requirement to increase the number of staff who provide direct services to students at schools with an enrollment of unduplicated students that is greater than 55 percent.

An LEA that does not have comparison schools from which to describe how it is using the concentration grant add-on funds, such as an LEA that only has schools with an enrollment of unduplicated students that is greater than 55 percent, must describe how it is using the funds to increase the number of credentialed staff, classified staff, or both, including custodial staff, who provide direct services to students at selected schools and the criteria used to determine which schools require additional staffing support.

In the event that an additional concentration grant add-on is not sufficient to increase staff providing direct services to students at a school with an enrollment of unduplicated students that is greater than 55 percent, the LEA must describe how it is using the funds to retain staff providing direct services to students at a school with an enrollment of unduplicated students that is greater than 55 percent.

Complete the table as follows:

- Provide the staff-to-student ratio of classified staff providing direct services to students with a concentration of unduplicated students that is 55 percent or less and the staff-to-student ratio of classified staff providing direct services to students at schools with a concentration of unduplicated students that is greater than 55 percent, as applicable to the LEA. The LEA may group its schools by grade span (Elementary, Middle/Junior High, and High Schools), as applicable to the LEA. The staff-to-student ratio must be based on the number of full time equivalent (FTE) staff and the number of enrolled students as counted on the first Wednesday in October of each year.
- Provide the staff-to-student ratio of certificated staff providing direct services to students at schools with a concentration of unduplicated students that is 55 percent or less and the staff-to-student ratio of certificated staff providing direct services to students at schools with a concentration of unduplicated students that is greater than 55 percent, as applicable to the LEA. The LEA may group its schools by grade span (Elementary, Middle/Junior High, and High Schools), as applicable to the LEA. The staff-to-student ratio must be based on the number of FTE staff and the number of enrolled students as counted on the first Wednesday in October of each year.

Action Tables

Complete the Data Entry Table for each action in the LCAP. The information entered into this table will automatically populate the other Action Tables. Information is only entered into the Data Entry Table, the Annual Update Table, the Contributing Actions Annual Update Table, and the LCFF Carryover Table. With the exception of the Data Entry Table, the word "input" has been added to column headers to aid in identifying the column(s) where information will be entered. Information is not entered on the remaining Action tables.

The following tables are required to be included as part of the LCAP adopted by the local governing board or governing body:

- Table 1: Total Planned Expenditures Table (for the coming LCAP Year)

- Table 2: Contributing Actions Table (for the coming LCAP Year)
- Table 3: Annual Update Table (for the current LCAP Year)
- Table 4: Contributing Actions Annual Update Table (for the current LCAP Year)
- Table 5: LCFF Carryover Table (for the current LCAP Year)

Note: The coming LCAP Year is the year that is being planned for, while the current LCAP year is the current year of implementation. For example, when developing the 2022–23 LCAP, 2022–23 will be the coming LCAP Year and 2021–22 will be the current LCAP Year.

Data Entry Table

The Data Entry Table may be included in the LCAP as adopted by the local governing board or governing body, but is not required to be included. In the Data Entry Table, input the following information for each action in the LCAP for that applicable LCAP year:

- **LCAP Year:** Identify the applicable LCAP Year.
- **1. Projected LCFF Base Grant:** Provide the total amount of LCFF funding the LEA estimates it will receive for the coming school year, excluding the supplemental and concentration grants and the add-ons for the Targeted Instructional Improvement Grant Program and the Home to School Transportation Program, pursuant to 5 CCR Section 15496(a)(8).
See EC sections 2574 (for COEs) and 42238.02 (for school districts and charter schools), as applicable, for LCFF apportionment calculations.
- **2. Projected LCFF Supplemental and/or Concentration Grants:** Provide the total amount of LCFF supplemental and concentration grants the LEA estimates it will receive on the basis of the number and concentration of unduplicated students for the coming school year.
- **3. Projected Percentage to Increase or Improve Services for the Coming School Year:** This percentage will not be entered; it is calculated based on the Projected LCFF Base Grant and the Projected LCFF Supplemental and/or Concentration Grants, pursuant to 5 CCR Section 15496(a)(8). This is the percentage by which services for unduplicated pupils must be increased or improved as compared to the services provided to all students in the coming LCAP year.
- **LCFF Carryover — Percentage:** Specify the LCFF Carryover — Percentage identified in the LCFF Carryover Table from the prior LCAP year. If a carryover percentage is not identified in the LCFF Carryover Table, specify a percentage of zero (0.00%).
- **Total Percentage to Increase or Improve Services for the Coming School Year:** This percentage will not be entered; it is calculated based on the Projected Percentage to Increase or Improve Services for the Coming School Year and the LCFF Carryover —

Percentage. This is the percentage by which the LEA must increase or improve services for unduplicated pupils as compared to the services provided to all students in the coming LCAP year.

- **Goal #:** Enter the LCAP Goal number for the action.
- **Action #:** Enter the action's number as indicated in the LCAP Goal.
- **Action Title:** Provide a title of the action.
- **Student Group(s):** Indicate the student group or groups who will be the primary beneficiary of the action by entering "All," or by entering a specific student group or groups.
- **Contributing to Increased or Improved Services?:** Type "Yes" if the action is included as contributing to meeting the increased or improved services; OR, type "No" if the action is **not** included as contributing to meeting the increased or improved services.
- If "Yes" is entered into the Contributing column, then complete the following columns:
 - **Scope:** The scope of an action may be LEA-wide (i.e., districtwide, countywide, or charterwide), schoolwide, or limited. An action that is LEA-wide in scope upgrades the entire educational program of the LEA. An action that is schoolwide in scope upgrades the entire educational program of a single school. An action that is limited in its scope is an action that serves only one or more unduplicated student groups.
 - **Unduplicated Student Group(s):** Regardless of scope, contributing actions serve one or more unduplicated student groups. Indicate one or more unduplicated student groups for whom services are being increased or improved as compared to what all students receive.
 - **Location:** Identify the location where the action will be provided. If the action is provided to all schools within the LEA, the LEA must indicate "All Schools." If the action is provided to specific schools within the LEA or specific grade spans only, the LEA must enter "Specific Schools" or "Specific Grade Spans." Identify the individual school or a subset of schools or grade spans (e.g., all high schools or grades transitional kindergarten through grade five), as appropriate.
- **Time Span:** Enter "ongoing" if the action will be implemented for an indeterminate period of time. Otherwise, indicate the span of time for which the action will be implemented. For example, an LEA might enter "1 Year," or "2 Years," or "6 Months."
- **Total Personnel:** Enter the total amount of personnel expenditures utilized to implement this action.
- **Total Non-Personnel:** This amount will be automatically calculated based on information provided in the Total Personnel column and the Total Funds column.

- **LCFF Funds:** Enter the total amount of LCFF funds utilized to implement this action, if any. LCFF funds include all funds that make up an LEA's total LCFF target (i.e., base grant, grade span adjustment, supplemental grant, concentration grant, Targeted Instructional Improvement Block Grant, and Home-To-School Transportation).
- **Note:** For an action to contribute towards meeting the increased or improved services requirement it must include some measure of LCFF funding. The action may also include funding from other sources, however the extent to which an action contributes to meeting the increased or improved services requirement is based on the LCFF funding being used to implement the action.
- **Other State Funds:** Enter the total amount of Other State Funds utilized to implement this action, if any.
- **Local Funds:** Enter the total amount of Local Funds utilized to implement this action, if any.
- **Federal Funds:** Enter the total amount of Federal Funds utilized to implement this action, if any.
- **Total Funds:** This amount is automatically calculated based on amounts entered in the previous four columns.
- **Planned Percentage of Improved Services:** For any action identified as contributing, being provided on a limited basis to unduplicated students, and that does not have funding associated with the action, enter the planned quality improvement anticipated for the action as a percentage rounded to the nearest hundredth (0.00%). A limited action is an action that only serves foster youth, English learners, and/or low-income students.
 - As noted in the instructions for the Increased or Improved Services section, when identifying a Planned Percentage of Improved Services, the LEA must describe the methodology that it used to determine the contribution of the action towards the proportional percentage. The percentage of improved services for an action corresponds to the amount of LCFF funding that the LEA estimates it would expend to implement the action if it were funded.

For example, an LEA determines that there is a need to analyze data to ensure that instructional aides and expanded learning providers know what targeted supports to provide to students who are foster youth. The LEA could implement this action by hiring additional staff to collect and analyze data and to coordinate supports for students, which the LEA estimates would cost \$165,000. Instead, the LEA chooses to utilize a portion of existing staff time to analyze data relating to students who are foster youth. This analysis will then be shared with site principals who will use the data to coordinate services provided by instructional assistants and expanded learning providers to target support to students. In this example, the LEA would divide the estimated cost of \$165,000 by the amount of LCFF Funding identified in the Data Entry Table and then convert the quotient to a percentage. This percentage is the Planned Percentage of Improved Service for the action.

Contributing Actions Table

As noted above, information will not be entered in the Contributing Actions Table; however, the ‘Contributing to Increased or Improved Services?’ column will need to be checked to ensure that only actions with a “Yes” are displaying. If actions with a “No” are displayed or if actions that are contributing are not displaying in the column, use the drop-down menu in the column header to filter only the “Yes” responses.

Annual Update Table

In the Annual Update Table, provide the following information for each action in the LCAP for the relevant LCAP year:

- **Estimated Actual Expenditures:** Enter the total estimated actual expenditures to implement this action, if any.

Contributing Actions Annual Update Table

In the Contributing Actions Annual Update Table, check the ‘Contributing to Increased or Improved Services?’ column to ensure that only actions with a “Yes” are displaying. If actions with a “No” are displayed or if actions that are contributing are not displaying in the column, use the drop-down menu in the column header to filter only the “Yes” responses. Provide the following information for each contributing action in the LCAP for the relevant LCAP year:

- **6. Estimated Actual LCFF Supplemental and/or Concentration Grants:** Provide the total amount of LCFF supplemental and concentration grants the LEA estimates it will actually receive based on of the number and concentration of unduplicated students in the current school year.
- **Estimated Actual Expenditures for Contributing Actions:** Enter the total estimated actual expenditure of LCFF funds used to implement this action, if any.
- **Estimated Actual Percentage of Improved Services:** For any action identified as contributing, being provided on a Limited basis only to unduplicated students, and that does not have funding associated with the action, enter the total estimated actual quality improvement anticipated for the action as a percentage rounded to the nearest hundredth (0.00%).
 - Building on the example provided above for calculating the Planned Percentage of Improved Services, the LEA in the example implements the action. As part of the annual update process, the LEA reviews implementation and student outcome data and determines that the action was implemented with fidelity and that outcomes for foster youth students improved. The LEA reviews the original estimated cost for the action and determines that had it hired additional staff to collect and analyze data and to coordinate supports for students that estimated actual cost would have been \$169,500 due to a cost of living adjustment. The LEA would divide the estimated actual cost of \$169,500 by the amount of LCFF Funding identified in the Data Entry Table and then convert the quotient to a percentage. This percentage is the Estimated Actual Percentage of Improved Services for the action.

LCFF Carryover Table

- **9. Estimated Actual LCFF Base Grant:** Provide the total amount of LCFF funding the LEA estimates it will receive for the current school year, excluding the supplemental and concentration grants and the add-ons for the Targeted Instructional Improvement Grant Program and the Home to School Transportation Program, pursuant to 5 CCR Section 15496(a)(8).

- **10. Total Percentage to Increase or Improve Services for the Current School Year:** This percentage will not be entered. The percentage is calculated based on the amounts of the Estimated Actual LCFF Base Grant (9) and the Estimated Actual LCFF Supplemental and/or Concentration Grants (6), pursuant to 5 CCR Section 15496(a)(8), plus the LCFF Carryover – Percentage from the prior year. This is the percentage by which services for unduplicated pupils must be increased or improved as compared to the services provided to all students in the current LCAP year.

Calculations in the Action Tables

To reduce the duplication of effort of LEAs, the Action Tables include functionality such as pre-population of fields and cells based on the information provided in the Data Entry Table, the Annual Update Summary Table, and the Contributing Actions Table. For transparency, the functionality and calculations used are provided below.

Contributing Actions Table

- 4. Total Planned Contributing Expenditures (LCFF Funds)
 - This amount is the total of the Planned Expenditures for Contributing Actions (LCFF Funds) column
- 5. Total Planned Percentage of Improved Services
 - This percentage is the total of the Planned Percentage of Improved Services column
- Planned Percentage to Increase or Improve Services for the coming school year (4 divided by 1, plus 5)
 - This percentage is calculated by dividing the Total Planned Contributing Expenditures (4) by the Projected LCFF Base Grant (1), converting the quotient to a percentage, and adding it to the Total Planned Percentage of Improved Services (5).

Contributing Actions Annual Update Table

- Pursuant to EC Section 42238.07(c)(2), if the Total Planned Contributing Expenditures (4) is less than the Estimated Actual LCFF Supplemental and Concentration Grants (6), the LEA is required to calculate the difference between the Total Planned Percentage of Improved Services (5) and the Total Estimated Actual Percentage of Improved Services (7). If the Total Planned Contributing Expenditures (4) is equal to or greater than the Estimated Actual LCFF Supplemental and Concentration Grants (6), the Difference Between Planned and Estimated Actual Percentage of Improved Services will display "Not Required."
- 6. Estimated Actual LCFF Supplemental and Concentration Grants
 - This is the total amount of LCFF supplemental and concentration grants the LEA estimates it will actually receive based on of the number and concentration of unduplicated students in the current school year.
 - 4. Total Planned Contributing Expenditures (LCFF Funds)
 - This amount is the total of the Last Year's Planned Expenditures for Contributing Actions (LCFF Funds)

- 7. Total Estimated Actual Expenditures for Contributing Actions
 - This amount is the total of the Estimated Actual Expenditures for Contributing Actions (LCFF Funds)
- Difference Between Planned and Estimated Actual Expenditures for Contributing Actions (Subtract 7 from 4)
 - This amount is the Total Estimated Actual Expenditures for Contributing Actions (7) subtracted from the Total Planned Contributing Expenditures (4)
- 5. Total Planned Percentage of Improved Services (%)
 - This amount is the total of the Planned Percentage of Improved Services column
- 8. Total Estimated Actual Percentage of Improved Services (%)
 - This amount is the total of the Estimated Actual Percentage of Improved Services column
- Difference Between Planned and Estimated Actual Percentage of Improved Services (Subtract 5 from 8)
 - This amount is the Total Planned Percentage of Improved Services (5) subtracted from the Total Estimated Actual Percentage of Improved Services (8)

LCFF Carryover Table

- 10. Total Percentage to Increase or Improve Services for the Current School Year (6 divided by 9 + Carryover %)
 - This percentage is the Estimated Actual LCFF Supplemental and/or Concentration Grants (6) divided by the Estimated Actual LCFF Base Grant (9) plus the LCFF Carryover – Percentage from the prior year.
- 11. Estimated Actual Percentage of Increased or Improved Services (7 divided by 9, plus 8)
 - This percentage is the Total Estimated Actual Expenditures for Contributing Actions (7) divided by the LCFF Funding (9), then converting the quotient to a percentage and adding the Total Estimated Actual Percentage of Improved Services (8).
- 12. LCFF Carryover — Dollar Amount LCFF Carryover (Subtract 11 from 10 and multiply by 9)
 - If the Estimated Actual Percentage of Increased or Improved Services (11) is less than the Estimated Actual Percentage to Increase or Improve Services (10), the LEA is required to carry over LCFF funds.

The amount of LCFF funds is calculated by subtracting the Estimated Actual Percentage to Increase or Improve Services (11) from the Estimated Actual Percentage of Increased or Improved Services (10) and then multiplying by the Estimated Actual LCFF Base Grant (9). This amount is the amount of LCFF funds that is required to be carried over to the coming year.

- 13. LCFF Carryover — Percentage (12 divided by 9)
 - This percentage is the unmet portion of the Percentage to Increase or Improve Services that the LEA must carry over into the coming LCAP year. The percentage is calculated by dividing the LCFF Carryover (12) by the LCFF Funding (9).

California Department of Education
January 2022

Local Performance Indicators

The State Board of Education (SBE) approved standards for the local indicators that support a local educational agency (LEA) in measuring and reporting progress within the appropriate priority area. The approved performance standards require an LEA to:

- Annually measure its progress in meeting the requirements of the specific Local Control Funding Formula (LCFF) priority.
- Report the results as part of a non-consent item at a regularly scheduled public meeting of the local governing board/body in conjunction with the adoption of the Local Control and Accountability Plan (LCAP).
- Report results to the public through the Dashboard utilizing the SBE-adopted self-reflection tools for each local indicator.

Performance Standards

The performance standards for the local performance indicators are:

Appropriately Assigned Teachers, Access to Curriculum-Aligned Instructional Materials, and Safe, Clean and Functional School Facilities (LCFF Priority 1)

The LEA annually measures its progress in meeting the *Williams* settlement requirements at 100% at all of its school sites, as applicable, and promptly addresses any complaints or other deficiencies identified throughout the academic year, as applicable; the LEA then reports the results to its local governing board at a regularly scheduled meeting and to reports to educational partners and the public through the Dashboard.

Local Control Funding Formula (LCFF) Priority 1 Self-Reflection Tools

An LEA uses the self-reflection tools included within the Dashboard to report its progress on the local performance indicator to educational partners and the public.

The self-reflection tools are embedded in the web-based Dashboard system and are also available in Word document format. In addition to using the self-reflection tools to report its progress on the local performance indicators to educational partners and the public, an LEA may use the self-reflection tools as a resource when reporting results to its local governing board. The approved self-reflection tools for Priority 1 are provided below.

Appropriately Assigned Teachers, Access to Curriculum-Aligned Instructional Materials, and Safe, Clean and Functional School Facilities (LCFF Priority 1)

LEAs will provide the information below:

- Number/percentage of misassignments of teachers of ELs, total teacher misassignments, and vacant teacher positions

For the 2021-22 school year, there were no misassignments for teachers of EL students, no teacher misassignments, and no vacant teacher positions.

- Number/percentage of students without access to their own copies of standards-aligned instructional materials for use at school and at home

Each year, as part of compliance with the Sufficiency of Instructional Materials under the William's settlement, the Board adopts a resolution acknowledging "the degree to which every pupil...has sufficient access to the standards-aligned instructional materials as determined pursuant to EC section 60119." This must be done at a public hearing no later than the 8th week of the school year as counted from the first day that students attend school. Principals verified that each student had access to the Board-approved materials in the core areas including electronic devices and internet access for distance learning, and the public hearing and resolution were completed at the October 4th, 2021 Board meeting.

- Number of identified instances where facilities do not meet the "good repair" standard (including deficiencies and extreme deficiencies)

All facilities meet the "good repair" standard. There were two sites that received an "exemplary" (Jordan and Olita). There was an area of deficiency at Meadow Green for roofing, which will be addressed in the 2022-23 school year as part of overall construction under Measure LL. Olita had a deficiency in the area of pest/vermin infestation on the playground. The frequency of the pest control service used by the district was increased to address this issue. Rancho had a deficiency for a roofing issue, which will also be addressed under Measure LL. El Portal had a deficiency for functional but outdated playground equipment. A single deficiency in a given area does not negate the overall rating of Good or Exemplary for our sites.

Note: The requested information are all data elements that are currently required as part of the School Accountability Report Card (SARC).

Implementation of State Academic Standards (LCFF Priority 2)

The LEA annually measures its progress implementing state academic standards; the LEA then reports the results to its local governing board at a regularly scheduled meeting and reports to educational partners and the public through the Dashboard.

Local Control Funding Formula (LCFF) Priority 2 Self-Reflection Tools

An LEA uses the self-reflection tools included within the Dashboard to report its progress on the local performance indicator to educational partners and the public.

The self-reflection tools are embedded in the web-based Dashboard system and are also available in Word document format. In addition to using the self-reflection tools to report its progress on the local performance indicators to educational partners and the public, an LEA may use the self-reflection tools as a resource when reporting results to its local governing board. The approved self-reflection tools for Priority 2 are provided below.

Implementation of State Academic Standards (LCFF Priority 2)

LEAs may provide a narrative summary of their progress in the implementation of state academic standards based on locally selected measures or tools (Option 1). Alternatively, LEAs may complete the *optional* reflection tool (Option 2).

OPTION 2: Reflection Tool

Recently Adopted Academic Standards and/or Curriculum Frameworks

- 1. Rate the LEA's progress in providing professional learning for teaching to the recently adopted academic standards and/or curriculum frameworks identified below.**

Rating Scale (lowest to highest): 1 – Exploration and Research Phase; 2 – Beginning Development; 3 – Initial Implementation; 4 – Full Implementation; 5 – Full Implementation and Sustainability

Academic Standards	1	2	3	4	5
ELA – Common Core State Standards for ELA					X
ELD (Aligned to ELA Standards)			X		
Mathematics – Common Core State Standards for Mathematics					X
Next Generation Science Standards			X		
History-Social Science					X

2. **Rate the LEA’s progress in making instructional materials that are aligned to the recently adopted academic standards and/or curriculum frameworks identified below available in all classrooms where the subject is taught.**
Rating Scale (lowest to highest): 1 – Exploration and Research Phase; 2 – Beginning Development; 3 – Initial Implementation; 4 – Full Implementation; 5 – Full Implementation and Sustainability

Academic Standards	1	2	3	4	5
ELA – Common Core State Standards for ELA					X
ELD (Aligned to ELA Standards)					X
Mathematics – Common Core State Standards for Mathematics					X
Next Generation Science Standards					X
History-Social Science					X

3. **Rate the LEA’s progress in implementing policies or programs to support staff in identifying areas where they can improve in delivering instruction aligned to the recently adopted academic standards and/or curriculum frameworks identified below (e.g., collaborative time, focused classroom walkthroughs, teacher pairing).**
Rating Scale (lowest to highest): 1 – Exploration and Research Phase; 2 – Beginning Development; 3 – Initial Implementation; 4 – Full Implementation; 5 – Full Implementation and Sustainability

Academic Standards	1	2	3	4	5
ELA – Common Core State Standards for ELA					X
ELD (Aligned to ELA Standards)			X		
Mathematics – Common Core State Standards for Mathematics					X
Next Generation Science Standards				X	
History-Social Science					X

Other Adopted Academic Standards

4. **Rate the LEA’s progress implementing each of the following academic**

standards adopted by the state board for all students.

Rating Scale (lowest to highest): 1 – Exploration and Research Phase; 2 – Beginning Development; 3 – Initial Implementation; 4 – Full Implementation; 5 – Full Implementation and Sustainability

Academic Standards	1	2	3	4	5
Career Technical Education				X	
Health Education Content Standards			X		
Physical Education Model Content Standards			X		
Visual and Performing Arts				X	
World Language			X		

Support for Teachers and Administrators

- Rate the LEA's success at engaging in the following activities with teachers and school administrators during the prior school year (including the summer preceding the prior school year).**

Rating Scale (lowest to highest): 1 – Exploration and Research Phase; 2 – Beginning Development; 3 – Initial Implementation; 4 – Full Implementation; 5 – Full Implementation and Sustainability

Activities	1	2	3	4	5
Identifying the professional learning needs of groups of teachers or staff as a whole				X	
Identifying the professional learning needs of individual teachers				X	
Providing support for teachers on the standards they have not yet mastered				X	

Optional Narrative (Limited to 1,500 characters)

Provide any additional information in the text box provided in the Dashboard that the LEA believes is relevant to understanding its progress implementing the academic standards adopted by the state board.

Teachers continue to have time for planning as a grade level to discuss standards and instruction on a regular basis. There is Instructional Team Planning (ITP meetings) at the site during early-release Mondays, and 3-4 of those meetings are coordinated for

district-wide grade level meetings throughout the year. Teachers typically have release days within the year to plan as a grade level in addition to three professional development days. With the high volume of absences due to isolation and quarantine, that has been more difficult in the last few years. The Dual Language Immersion teachers were released for 2 days of planning and review of materials as were about 30 teachers for participation in the adoption of new science materials. All teachers will receive training on the new materials in August of 2022. We continue to support the increased amount of instruction provided in relation to VAPA standards as well with the addition of more systemized art instruction for the elementary sites in partnership with the Muckenthaler Center. We have a World Language elective for Spanish at Rancho and a Dual Immersion program at one of our sites, which now services TK-4th grade students. With the coming release of the mathematics framework, we will begin the process of review for mathematics upon completion of the science adoption. We purchased a more robust assessment system (iReady) to be able to monitor student progress on state standards throughout the year for both Language Arts and Mathematics. Ongoing professional development was provided after each benchmark throughout the 2021-22 school year to support the analysis of data and subsequent planning for instruction to differentiate based on student need. This will support the development of mastery in standards for students as well as provide the springboard for training of teachers as they evaluate gaps in learning and need to make adjustments instructionally.

Parent and Family Engagement (LCFF Priority 3)

This measure addresses Parent and Family Engagement, including how an LEA builds relationships between school staff and families, builds partnerships for student outcomes and seeks input for decision-making.

LEAs report progress of how they have sought input from parents in decision-making and promoted parent participation in programs to its local governing board or body using the SBE-adopted self-reflection tool for Priority 3 at the same meeting at which the LEA adopts its LCAP, and reports to educational partners and the public through the Dashboard.

Parental Involvement and Family Engagement (LCFF Priority 3)

Introduction

Family engagement is an essential strategy for building pathways to college and career readiness for all students and is an essential component of a systems approach to improving outcomes for all students. More than 30 years of research has shown that family engagement can lead to improved student outcomes (e.g., attendance, engagement, academic outcomes, social emotional learning, etc.).

Consistent with the California Department of Education's (CDE's) Family Engagement Toolkit:¹

- Effective and authentic family engagement has been described as an intentional partnership of educators, families and community members who share responsibility for a child from the time they are born to becoming an adult.
- To build an effective partnership, educators, families, and community members need to develop the knowledge and skills to work together, and schools must purposefully integrate family and community engagement with goals for students' learning and thriving.

The LCFF legislation recognized the importance of family engagement by requiring LEAs to address Priority 3 within their LCAP. The self-reflection tool described below enables LEAs to reflect upon their implementation of family engagement as part of their continuous improvement process and prior to updating their LCAP.

For LEAs to engage all families equitably, it is necessary to understand the cultures, languages, needs and interests of families in the local area. Furthermore, developing family engagement policies, programs, and practices needs to be done in partnership with local families, using the tools of continuous improvement.

Instructions

This self-reflection tool is organized into three sections. Each section includes research and evidence-based practices in family engagement:

1. Building Relationships between School Staff and Families
2. Building Partnerships for Student Outcomes
3. Seeking Input for Decision-Making

Based on an evaluation of data, including educational partner input, an LEA uses this self-reflection tool to report on its progress successes and area(s) of need related to family engagement policies, programs, and practices. This tool will enable an LEA to engage in continuous improvement and determine next steps to make improvements in the areas identified. The results of the process should be used to inform the LCAP and its development process, including assessing prior year goals, actions and services and in modifying future goals, actions, and services in the LCAP.

LEAs are to implement the following self-reflection process:

1. Identify the diverse educational partners that need to participate in the self-reflection process in order to ensure input from all groups of families, staff and students in the LEA, including families of unduplicated students and families of individuals with exceptional needs as well as families of underrepresented students.
2. Engage educational partners in determining what data and information will be considered to complete the self-reflection tool. LEAs should consider how the practices apply to families of all student groups, including families of unduplicated students and families of individuals with exceptional needs as well as families of underrepresented students.
3. Based on the analysis of educational partner input and local data, identify the number which best indicates the LEA's current stage of implementation for each of the 12 practices using the following rating scale (lowest to highest):
 - 1 – Exploration and Research
 - 2 – Beginning Development
 - 3 – Initial Implementation
 - 4 – Full Implementation
 - 5 – Full Implementation and Sustainability
4. Based on the analysis of educational partner input and local data, respond to each of the prompts pertaining to each section of the tool.
5. Use the findings from the self-reflection process to inform the annual update to the LCAP and the LCAP development process, as well as the development of other school and district plans.

Sections of the Self-Reflection Tool

Section 1: Building Relationships Between School Staff and Families

Based on the analysis of educational partner input and local data, identify the number which best indicates the LEA's current stage of implementation for each practice in this section using the following rating scale (lowest to highest):

- 1 – Exploration and Research
- 2 – Beginning Development
- 3 – Initial Implementation
- 4 – Full Implementation
- 5 – Full Implementation and Sustainability

Practices	Rating Scale Number
1. Rate the LEA's progress in developing the capacity of staff (i.e., administrators, teachers, and classified staff) to build trusting and respectful relationships with families.	5
2. Rate the LEA's progress in creating welcoming environments for all families in the community.	5
3. Rate the LEA's progress in supporting staff to learn about each family's strengths, cultures, languages, and goals for their children.	3
4. Rate the LEA's progress in developing multiple opportunities for the LEA and school sites to engage in 2-way communication between families and educators using language that is understandable and accessible to families.	3

Building Relationships Dashboard Narrative Boxes (Limited to 3,000 characters)

1. Based on the analysis of educational partner input and local data, briefly describe the LEA's current strengths and progress in Building Relationships Between School Staff and Families.

When asked to rate the statement "Our staff provides a high level of service for my student and my family", 92% of families Agree or Strongly Agree with 94% for

the statement “Our school staff has provided a welcoming and supportive experience through these uniquely challenging times”. 95% of families responding to the survey Agree or Strongly Agree with the statement “Our school is friendly, pleasant, respectful, and welcoming” with 91% for the statement “Our staff makes parents feel welcome and part of our school”. In addition to comments made, these are strong indicators of the positive relationships that exist between Lowell Joint staff and families. Many of the staff in Lowell Joint are families within the community and 34% of the families responding to the survey have had multiple generations attend Lowell schools.

2. Based on the analysis of educational partner input and local data, briefly describe the LEA’s focus area(s) for improvement in Building Relationships Between School Staff and Families.

Staff had a unique window into the lives of some of our families during distance learning with students being at home and on camera for classes. There was a recognition for many staff around the disparity for students in terms of resources, support, and living conditions with 56% of our students qualifying for Free/Reduced lunch up from 40% in the prior year. Food insecurities, loss of employment, and other issues related to the pandemic have created a renewed desire to understand trauma-informed care as it relates to our staff and working with students and families. This will be an area of focus as the District continues to add to overall supports around Social Emotional Learning and mental health. It’s clear that families feel welcomed by staff, and this added layer will hopefully move families to deeper levels of involvement.

3. Based on the analysis of educational partner input and local data, briefly describe how the LEA will improve engagement of underrepresented families identified during the self-reflection process in relation to Building Relationships Between School Staff and Families.

The District has small pockets of languages other than Spanish, so a first step would be to survey families in their native language where possible to determine strategies to increase overall engagement for our non or limited English families. The increased offerings for before and after school provide additional avenues to connect with parents around family needs that can support decisions about programming since ELOP targets our Unduplicated Pupil count (English Learners, Foster Youth, and Free/Reduced Lunch).

Section 2: Building Partnerships for Student Outcomes

Based on the analysis of educational partner input and local data, identify the number which best indicates the LEA’s current stage of implementation for each practice in this section using the following rating scale (lowest to highest):

- 1 – Exploration and Research
- 2 – Beginning Development

- 3 – Initial Implementation
- 4 – Full Implementation
- 5 – Full Implementation and Sustainability

Practices	Rating Scale Number
5. Rate the LEA's progress in providing professional learning and support to teachers and principals to improve a school's capacity to partner with families.	3
6. Rate the LEA's progress in providing families with information and resources to support student learning and development in the home.	4
7. Rate the LEA's progress in implementing policies or programs for teachers to meet with families and students to discuss student progress and ways to work together to support improved student outcomes.	5
8. Rate the LEA's progress in supporting families to understand and exercise their legal rights and advocate for their own students and all students.	4

Building Partnerships Dashboard Narrative Boxes (Limited to 3,000 characters)

1. Based on the analysis of educational partner input and local data, briefly describe the LEA's current strengths and progress in Building Partnerships for Student Outcomes.

Families are very connected to student outcomes and ongoing communication around student progress. 93% of survey respondents feel that Lowell Joint provides a strong, core academic instructional program with over 92% Agreeing/Strongly Agreeing that the program is balanced in terms of core course offerings (language arts, mathematics, science, social studies, art, music, physical education, etc.).

2. Based on the analysis of educational partner input and local data, briefly describe the LEA's focus area(s) for improvement in Building Partnerships for Student Outcomes.

An area for growth, confirmed by both survey data and in input meetings, centers around the need to support enrichment and rigor for our GATE students. We are

beginning with the certification of all teachers in GATE having completed about half of teachers within the district in the 2021-22 school year. All 2nd graders were given a universal screener as one measure in identifying giftedness. As teachers increase focus on depth and complexity in the classroom, additional enrichment opportunities are being developed to address this need. When asked about opportunities for students to work above grade level, 63% of respondents Agree/Strongly Agree with 26% marking "Don't Know". This speaks to the need to both increase opportunities and communicate with parents around services in support of our gifted and talented students.

3. Based on the analysis of educational partner input and local data, briefly describe how the LEA will improve engagement of underrepresented families identified during the self-reflection process in relation to Building Partnerships for Student Outcomes.

The Educational Services department has worked diligently to ensure that the identification process for gifted and talented services is all-inclusive. Using multiple measures with an opt out model for universal screening ensures access for all students as a baseline. Nonverbal elements to the assessment will help control for language issues in our English learners. Measures for creativity and leadership will also help widen the net for including students in the identification process. Training all teachers has been a vital part of the overall plan to ensure that teachers recognize the elements of giftedness regardless of formal identification. This includes our primary teachers in grades TK-2nd before students are even formally assessed as well as upper grade teachers for those students who demonstrate giftedness after formal identification. We are working on the overall system for additional assessments for students entering the district after 2nd grade and for those not identified initially. All of this is designed to ensure that students traditionally underrepresented in GATE programs are having their needs met through a robust system of supports.

Section 3: Seeking Input for Decision-Making

Based on the analysis of educational partner input and local data, identify the number which best indicates the LEA's current stage of implementation for each practice in this section using the following rating scale (lowest to highest):

- 1 – Exploration and Research
- 2 – Beginning Development
- 3 – Initial Implementation
- 4 – Full Implementation
- 5 – Full Implementation and Sustainability

Practices	Rating Scale Number
9. Rate the LEA's progress in building the capacity of and supporting principals and staff to effectively engage families in advisory groups and with decision-making.	3
10. Rate the LEA's progress in building the capacity of and supporting family members to effectively engage in advisory groups and decision-making.	3
11. Rate the LEA's progress in providing all families with opportunities to provide input on policies and programs, and implementing strategies to reach and seek input from any underrepresented groups in the school community.	4
12. Rate the LEA's progress in providing opportunities to have families, teachers, principals, and district administrators work together to plan, design, implement and evaluate family engagement activities at school and district levels.	3

Seeking Input for Decision-Making Dashboard Narrative Boxes (Limited to 3,000 characters)

1. Based on the analysis of educational partner input and local data, briefly describe the LEA's current strengths and progress in Seeking Input for Decision-Making.

Each year, a Parent Survey is conducted in the spring to monitor parent engagement and obtain feedback from parents related to state priorities and local indicators as they align with both district and school goals within the Local Control Accountability Plan (LCAP) at the district level and the School Plan for Student Achievement (SPSA) at the site level. The survey was created to align with state and local priorities in six areas: Student Achievement/Course Access, Student Engagement, School Climate, Basic Services, Implementation of State Standards, Parent and Family Engagement. There is a section specific to parents of English Learners, and the survey is provided in both Spanish and English. While it is sent electronically, hard copies are always available on site for a family if needed. In addition to the LCAP Parent Advisory Committee, district personnel attended PTA meetings for each site to review the LCAP and ask for input from parents for determining actions and priorities in meeting the needs of students in Lowell Joint. The Superintendent meets regularly with the PTA as well. A section of the Parent Survey targets Parent and Family Engagement specifically. 93% of respondents Agree or Strongly Agree that they feel comfortable initiating discussion with school staff regarding academic behavior or social concerns,

which is a slight decrease (1%) from the 2021 survey. Over 99% have electronic devices to receive digital communication with 95% who Agree or Strongly Agree that the schools provide a variety of ongoing communication to inform parents about their student's academic progress, which is the same as 2021. The survey was designed by LJSD to align with specific areas of the Local Control Accountability Plan (LCAP) to measure progress on both state priorities and District goals. Results of the Parent Survey are shared with the Board annually in September, and the Principals are given site specific data to plan for parent and family engagement. There is an open-ended section on the survey for input related to the goals within the LCAP in addition to the face-to-face opportunities for parents to speak into the decision making process at both the site and district levels. Bilingual aides called an additional 50+ English learner families (over 20% of the EL population) to ensure representation in addition to DELAC input and other UPP parents on both district committees and in the PTA.

2. Based on the analysis of educational partner input and local data, briefly describe the LEA's focus area(s) for improvement in Seeking Input for Decision-Making.

When asked if parents and families are aware of and have multiple opportunities to be involved in their child's educational experience, 88% of respondents Agree or Strongly Agree. This is down 7% from the 2021 survey. Some of this can be attributed to COVID restrictions and protocols that did not allow for as many parental opportunities on campus throughout the year; however, this is an area for growth in terms of identifying ways to improve input. We had an extremely high rate of return for input during COVID including 1300 responses (about 60% of families) last year compared to prior years at about 450 responses. It dropped back down to about 800 this year. We had fewer parents attend the LCAP Advisory and Parent Advisory Committee meetings although we had high numbers for the PTA meetings in terms of getting parental input.

3. Based on the analysis of educational partner input and local data, briefly describe how the LEA will improve engagement of underrepresented families identified during the self-reflection process in relation to Seeking Input for Decision-Making.

As mentioned above, the District has focused on reaching out to families above and beyond the general lines of communication to ensure input in the decision-making process. As things are normalizing after COVID, the goal would be to work collaboratively with engaged parents and staff members to identify ways to increase involvement and encourage partnership with our underrepresented families. For example, the District has small pockets of languages other than Spanish, so a first step would be to survey families in their native language where possible to determine strategies to increase overall engagement for our English learners. The increased offerings for before and after school provide additional avenues to connect with parents around family needs that can support decisions about programming.

School Climate (LCFF Priority 6)

The LEA administers a local climate survey **at least every other year** that provides a valid measure of perceptions of school safety and connectedness, such as the California Healthy Kids Survey, to students in at least one grade within the grade span(s) that the LEA serves (e.g., K-5, 6-8, 9-12), and reports the results to its local governing board at a regularly scheduled meeting of the local governing board and to educational partners and the public through the Dashboard.

LEAs will provide a narrative summary of the local administration and analysis of a local climate survey that captures a valid measure of student perceptions of school safety and connectedness in at least one grade within the grade span (e.g., K–5, 6– 8, 9–12) in a text box provided in the California School Dashboard (response limited to 3,000 characters). LEAs will have an opportunity to include differences among student groups, and for surveys that provide an overall score, such as the California Healthy Kids Survey, report the overall score for all students and student groups. This summary may also include an analysis of a subset of specific items on a local survey and additional data collection tools that are particularly relevant to school conditions and climate.

1. **DATA:** Reflect on the key learnings from the survey results and share what the LEA learned.
2. **MEANING:** What do the disaggregated results (*if applicable*) of the survey and other data collection methods reveal about schools in the LEA, such as areas of strength or growth, challenges, and barriers?
3. **USE:** What revisions, decisions, or actions has, or will, the LEA implement in response to the results for continuous improvement purposes? Why? If you have already implemented actions, did you see the results you were seeking?

We had 497 responses to the School Climate survey for students in addition to a few questions from the parent survey that ask about how their kids perceive school. The respondents are primarily 7th and 8th grade students this year after surveying all of grades 3-8 last year. From the parent survey, 93% of parents Agree or Strongly Agree that their student is happy to go to school. This is a 9% increase from 2021, which is somewhat understandable given students return to school. 94% of parents also Agree or Strongly Agree that the schools are “safe, orderly, and well disciplined”, which is a 5% increase. Each Principal has been given the disaggregated data for their site to use in planning for the upcoming year.

For our students, 81% of kids say they are happy to go to school which is a 12% increase from 2021. Interestingly enough, 12% had marked “Don’t Know” in 2021. When asked if they felt the school helps set high goals for their future and prepares them for college/career, 81% marked Strongly Agree or Agree which is up 3%. 77% of students felt safe at school, which is down 11% and could be a reflection of spending the majority of the year on campus versus distance learning in 2021.

As Principals are analyzing their site specific data, we will do some more disaggregating by grade, student group, etc. to determine if there are any student groups that are

experiencing negative aspects of school climate more than others. From both the survey results and feedback throughout the 2021-2021 school year, families were extremely appreciative of the efforts to meet the needs of their students despite great challenges.

For the district as a whole, attendance and suspension/expulsion data often used in part as measures of student engagement, are not extremely reliable this year. With the number of students out due to isolation and quarantine throughout the year, it would be difficult to measure student engagement by these numbers. Only 75% of students responding to the survey felt that they had an identified adult on campus if they needed to go to someone for help. This is a concern given that this number historically has been in the 90% range. This may very well be a product of the pandemic, but it is of concern in terms of student connectedness on campus. Anecdotally, students are happy to be back and adjusting well, so additional conversations with students and support personnel to get at the root of some of these school climate concerns are necessary. The District will continue to hire both counseling and psych interns to increase the number of students that can be served by support personnel. Care Solace has been added as a third-party vendor to help families navigate the health care system in connecting with mental health services. The District will continue to provide training and resources for teachers as we add to our overall system of supports in the area of social emotional well-being and mental health.

Access to a Broad Course of Study (LCFF Priority 7)

The LEA annually measures its progress in the extent to which students have access to, and are enrolled in, a broad course of study that includes the adopted courses of study specified in the California *Education Code (EC)* for Grades 1-6 and Grades 7-12, as applicable, including the programs and services developed and provided to unduplicated students and individuals with exceptional needs; the LEA then reports the results to its local governing board at a regularly scheduled meeting and reports to educational partners and the public through the Dashboard.

LEAs provide a narrative summary of the extent to which all students have access to and are enrolled in a broad course of study by addressing, at a minimum, the following four prompts:

1. Briefly identify the locally selected measures or tools that the LEA is using to track the extent to which all students have access to, and are enrolled in, a broad course of study, based on grade spans, unduplicated student groups, and individuals with exceptional needs served. (response limited to 1,500 characters)

For the elementary levels, teachers submit their daily schedule with clearly identified time blocks for all core subjects including ELD. Calendars and schedules for art, music, coding, computer lab time, STEAM lab rotations, and other programs are also monitored for access. At the intermediate level, the master schedule and student rosters are used to monitor access and enrollment. Individual student groups are monitored throughout the year for

involvement in both enrichment and intervention opportunities to ensure access to supports to increase academic success. This is monitored through sign in sheets as well as flexible grouping rosters that change throughout the year based on need. A Coordinator position was created for the 2022-23 school year with the additional Expanded Learning Opportunities Program to ensure access for Unduplicated Pupils (UPPs-Free/Reduced Lunch, Foster Youth, English Learners) through monitoring participation in before and after school intervention and enrichment in addition to intersession opportunities for the additional 30 days.

2. Using the locally selected measures or tools, summarize the extent to which all students have access to, and are enrolled in, a broad course of study. The summary should identify any differences across school sites and student groups in access to, and enrollment in, a broad course of study, and may describe progress over time in the extent to which all students have access to, and are enrolled in, a broad course of study. (response limited to 1,500 characters)

All students have access to and are enrolled in a broad course of study within the district. This includes all required content areas (mathematics, English Language Arts, Science, History/Social Science, PE) and a variety of enrichment and support opportunities throughout the day. All students across the district are provided time with a certificated music teacher for choral instruction at the elementary level with courses offered in 7th and 8th grade for students who choose to continue. All 6th grade students are given access to band if they choose to participate in addition to offerings at the intermediate level that also include Drumline. With Chromebooks for all grades, students have access to technology for the purposes of developing keyboarding skills and learning how to become good digital citizens in addition to its integration into rigorous learning in developing 21st century skills. STEAM labs have been developed at each elementary site with a robust STEAM pathway at Rancho Starbuck that includes AP Computer Science. Rancho also has a Design and Construction course and offers Robotics for students. A STEAM TOSA ensures opportunities for students to access resources within the STEAM labs. The District has purchased items for each lab to create an equitable baseline for access. This includes Ozobots, Strawbees, Spheros, a green-screen set up, Breakout boxes, supplies for art, and furniture where needed. The award-winning Flex program at Rancho Starbuck provides additional access to enrichment opportunities ranging from learning calligraphy to cooking. As a district, we are developing a more formalized GATE program including identification, training for all teachers, and enrichment opportunities open to all interested students while focusing on meeting the needs of our GATE students. The Dual Immersion program for TK-4th grade at one site and the Spanish elective for Rancho continue to support the development of offerings around World Languages. The Dual Immersion program will add a grade each year as it grows. A Music Production course, Drama, Art, Choir, Band, Drumline, and other offerings support the students that opt in to the Conservatory of the Fine Arts capstone project at Rancho. For the 2022-23 school year, in partnership with the Muckenthaler Center, we will be providing more structured art

opportunities with visiting artists at each grade level for elementary. A new adoption for core Art curriculum at the intermediate level was purchased in 2021-22 in alignment with the state framework.

3. Given the results of the tool or locally selected measures, identify the barriers preventing the LEA from providing access to a broad course of study for all students. (response limited to 1,500 characters)

All students receive a broad course of study. Additional personnel would certainly allow us to increase offerings and time allotted for various programs (art, music, coding, languages, etc.) We are currently organizing how to facilitate similar opportunities at all sites for ELOP since we do not have busing available within the district. One of our biggest growth areas is in the Dual Language Immersion (DLI) Program, so we do have some students on a wait list that the District is looking for ways to accommodate.

4. In response to the results of the tool or locally selected measures, what revisions, decisions, or new actions will the LEA implement, or has the LEA implemented, to ensure access to a broad course of study for all students? (response limited to 1,500 characters)

The new partnership with the Muckenthaler Center is allowing us to significantly increase art opportunities at the elementary level. We are also looking into ways to increase the focus on PE standards and practice throughout the District in response to input as part of the LCAP process. The STEAM TOSA is exploring different coding platforms to expand opportunities for students beyond existing offerings. With the addition of ELOP funding, we are continuing to develop enrichment and intervention opportunities for both before and after school that will broaden the scope of offerings for students based on both interest and need. We have increased offerings for all 4-year olds as well as part of the Universal Pre-Kindergarten requirements. This includes additional students in the Transitional Kindergarten program as well as preschool offerings. The Learning Link services children ages 0-5 who attend with their parent to help build school readiness skills and provide some parent training. We will continue to look at opportunities to expand programs in an effort to address the whole child.

Lowell Joint School District

Universal Pre-Kindergarten Planning and Implementation Grant Program

Grant Overview

CDE Grant Allocation: \$100,000 Additional per pupil: \$29,000 Total: \$129,000

Grant funds may be used for costs associated with creating or expanding CSPP or TK programs, or to establish or strengthen partnerships with other providers of prekindergarten education within the LEA, including Head Start programs, to ensure that high-quality options for prekindergarten education are available for four-year-old children. Allowable costs include, but are not limited to: (1) planning costs, (2) hiring and recruitment costs, (3) staff training and professional development, (4) classroom materials, and (5) supplies.

In addition, the 2021–22 State Budget also established the Expanded Learning Opportunities Program (ELO-P). The intent of the program is that all LEAs offer all **unduplicated students** in classroom-based instructional programs access to comprehensive after school and intersessional expanded learning opportunities. The **ELO-P requires LEAs to offer in-person before or after-school expanded learning opportunities** that, when added to the core instructional day, are no fewer than nine hours of combined instructional time and expanded learning opportunities per instructional day (*EC Section 46120*).

Focus Area A: Vision and Coherence

Recommended Planning Questions

The CDE recommends LEAs prioritize these questions as part of their UPK Plan in addition to required questions.

1. What is the LEA's vision for UPK?

The vision of the Lowell Joint School District (LJSD) is to ensure all children have early access to high quality, developmentally appropriate services that intentionally nurture and support the whole child and their family.

2. In addition to TK, what service delivery models will be integrated to offer UPK programming, including the nine hours of total extended learning and care programming around the TK instructional time for families that opt in? In developing this component of the plan, LEAs should include partners such as CSPP, Head Start, and other early

learning and care providers to ensure local services and funding are maximized and coordinated in response to parental needs and choice.

In addition to Universal Transitional Kindergarten (UTK) that will include eligibility for all four year olds by 2025-26 with students turning four by September 1st, 2025. LJSD has two different options for TK students to enroll in for expanded learning opportunities. Transitional Kindergarten students will have the opportunity to enroll in the district's expanded learning program that offers before and after school enrichment and intervention (Spark Academy). LJSD will use ELOP Funds for UPP students. Non UPP students will be eligible for our fee-based before and after school programs.

LJSD will be opening two Preschool programs this fall that will serve CSPP eligible children as well as fee-based children. One site will be a part day program - 3 hours in the morning and 3 hours in the afternoon; and one site will be a full day program that operates the length of the school day with before and after school care available.

A Learning Link is also available to service children 0-5 accompanied by a parent or guardian to help develop school readiness skills.

3. Describe the planned administrative structure that will support and monitor the UPK program and facilitate connections with the ELO-P as well as non-LEA-administered early learning and care programs that will support the extended learning components of UPK.

LJSD's Educational Services division is headed up by an Assistant Superintendent who will oversee two leadership positions in support of Universal Pre-Kindergarten (UPK). The Assistant Superintendent and Coordinator of Child Development Services will provide direct oversight of all UPK programs. Expanded Learning programs are overseen by the Expanded Learning Coordinator, who is also a part of the Educational Services Department. This management team meets on a regular basis in order to evaluate programs by looking at data and assessments to see how well students are progressing in the programs. Monthly meetings with the Instructional Cabinet including all Principals will ensure the dissemination of key information and cohesiveness across all sites. Both Coordinators will work with non-LEA programs to support the overall offerings to meet the needs of families within the district. Discussions for support from providers like the Boys and Girls Club and Options are currently being facilitated in addition to partnerships for specialized offerings such as art through the Muckenthaler Center.

4. Identify and assign each individual that will be responsible for key functions pertaining to implementing UPK (for example, academic or educational services, early childhood, facilities, human resources and labor, special education, English learner or multilingual programs, partnerships, including early learning and care and ELO-P, assessment and data collection, professional learning, workforce recruitment and preparation support, or others).

UPK Leadership Team

Educational Services - Assistant Superintendent, Director of Educational Services, Coordinator of Child Development Services, Early Learning Specialist (TOSA), Office Manager Special Programs, Site Supervisors for CSPP

Transitional Kindergarten-Certificated Teachers and Classified Aides

Expanded Learning - Coordinator of Expanded Learning

Facilities and Operations - Assistant Superintendent of Facilities and Operations
Human Resources - Assistant Superintendent of Administrative Services, Executive Assistant to the Superintendent/Certificated Personnel
Special Education - Director and Program Specialist
Business Services- Director of Fiscal Services, Fiscal Clerk for Special Programs

5. Identify how UPK leadership will be integrated in the decision-making process at the executive or cabinet level.

The Assistant Superintendent of Educational Services serves on the executive cabinet and all involved administrators serve on the Superintendent's Instructional Cabinet. Both teams meet regularly. The Assistant Superintendent is responsible for informing the other members of the executive cabinet of decisions and implementation of UPK across the school district.

6. Describe how the LEA's proposed UPK model will be integrated with the district's LCAP.

The proposed UPK model will be incorporated into the LCAP under Goal 2 around Early Learning, which includes all proposed staffing costs and program related planning and budgeting. The Assistant Superintendent of Educational Services oversees the LCAP process along with UPK. This process includes meeting with various interest groups throughout the year such as PTA/PTO, teachers, administrators, DELAC, the Parent Advisory Committee, the LCAP Advisory Committee, and both certificated and classified unions. UPK was discussed at all Educational Partner meetings throughout the 2021-22 school year to get feedback for the planning process.

7. Describe how the LEA plans to ensure the inclusion of students with disabilities in UPK classrooms and who will be involved in the process.

We have specialized programs (including mild-moderate and moderate-severe special day classes) available to meet the needs of students with disabilities. The inclusion of students with disabilities is a part of the Special education and Early Learning collaboration model. We also offer specialized services for students with identified learning disabilities who are enrolled in general education classes. With the addition of state-funded preschool programs under CSPP, a minimum of 10% of students enrolled in the preschools will qualify for special education services. LJSD already has a special education preschool housed at Meadow Green, so having two additional preschool sites will allow for much more flexibility and inclusion with general education peers. The Learning Link has also been a space to service some of our special education students that are not yet in preschool or attending only a part day preschool. The staff member who runs the Learning Link has also been an Instructional Assistant in the special education preschool. These pre-established relationships have supported successful inclusion of the students in the Learning Link.

8. Describe how the LEA plans to support sites in building connections between them and ELO-P, as well as early learning and care partners.

Early Learning and Expanded Learning are in the same department under Educational Services. Currently, LJSD has a plan to operate all Early Learning and Expanded Learning programs at every elementary site across the school district. Coordinators meet with school

principals on a regular basis to provide updates about the program and brainstorm how they can work together to serve the families in the community.

Required Questions

CDE will be requiring this information to be completed after the plan is presented to the governing board.

1. Which of the following model(s) of service delivery does the LEA plan to implement for UPK for all four-year-old children, including classes fully inclusive of children with disabilities, to provide access to the least restrictive environment for learning? [select all that apply]

- a. TK offered at all sites
- b. TK offered at some sites
- c. TK stand-alone classes
- d. TK and kindergarten combination classes
- e. CSPP and TK combination classes (CSPP funding and ADA funding)
- f. Locally-funded preschool and TK combination classes
- g. CSPP stand-alone classes
- h. Head Start stand-alone classes
- i. Other [describe, open response]

2. Does the LEA plan to implement full-day TK, part-day TK, or both?^[1] [select one]

- a. Full Day TK
- b. Part Day TK
- c. Both

3. Describe how the model(s) of service delivery selected in the preceding two questions will be implemented across the LEA's sites and why. [open response]

LJSD currently offers a full day transitional kindergarten at each elementary school. We are committed to continuing this model. When TK first began in the district it was a part day model. It became evident that a full day model was needed to better serve our families and meet the needs of our TK population in getting them ready for Kindergarten.

4. Does the LEA plan to begin operating a CSPP or expand its current CSPP contract? [select one]

- a. Yes - the LEA applied to expand its existing CSPP contract in 2022–23 (**Full Day Application**)
- b. Yes - the LEA applied for a new CSPP contract in 2022–23
- c. Yes - the LEA will apply to expand its existing CSPP contract in future years (if funding is appropriated by the legislature)
- d. Yes - the LEA plans to apply to administer a CSPP contract in future years (if funding is appropriated by the legislature)
- e. No - the LEA has no plans to begin or expand a CSPP contract in future years
- f. No - the LEA plans to relinquish or reduce CSPP services in future years

5. If the LEA answered yes in question four, what age of children does the LEA plan to serve through a CSPP contract? [select all that apply]

- a. Three-year-old children

- b. **Four-year-old children who will not be enrolled in TK in the current school year**
 - c. Four-year-old children who will be enrolled in early admittance TK on their fifth birthday but who are not yet enrolled because their birthday does not fall in the range for which LEAs are fully funded to support TK. (Note: children whose birthdays fall outside of this range can be served in TK at LEA option from the beginning of the school year, but LEAs only generate ADA after the child's fifth birthday.)
 - d. Four-year-old children who are enrolled in TK, including early admittance TK (CSPP would provide extended learning and care in addition to the TK instructional day).
6. Please indicate if the LEA plans to serve students eligible for early admittance TK, for children whose fifth birthday occurs after the enrollment date for the year of implementation (see implementation timeline above)?
- a. 2022–23 (Birthdays February 3 or after) [select one]
 - i. **Yes**
 - ii. No
 - iii. Maybe
 - b. 2023–24 (Birthdays April 3 or after) [select one]
 - i. **Yes**
 - ii. No
 - iii. Maybe
 - c. 2024–25 (Birthdays June 3 or after) [select one]
 - i. **Yes**
 - ii. No
 - iii. Maybe

Focus Area B: Community Engagement and Partnerships

To successfully implement UPK and create a P–3 continuum, LEAs will need to cultivate relationships and collaborate with both internal and external partners.

Recommended Planning Questions

The CDE recommends LEAs prioritize these questions as part of their UPK Plan in addition to required questions below.

1. How does the LEA's UPK Plan prioritize parental needs and choices?

LJSD has identified one of our LCAP goals around early childhood services and has allocated actionable funds to ensure that services and programs are based on stakeholder feedback. Parents have an opportunity to provide input to the LCAP through an annual survey to all families, meetings throughout the year for both Coffee with Coombs and the LCAP specifically, the Parent Advisory Committee, the LCAP Advisory Committee, and through regularly scheduled meetings with the PTA for both the LCAP and other general information. The Coordinators for Expanded Learning and Early Learning are working together to create a menu of options for before and after school options that include both intervention and enrichment as well as basic child care to service expressed parental needs within the district.

2. How does the LEA plan to meaningfully engage extended learning and care partners in the development of the LEA's UPK Plan?

The two new Coordinator positions that were created to support Universal Pre-Kindergarten (UPK) and P-3 alignment along with Expanded Learning Opportunities (ELO-P) are working together to develop the opportunities to support our four and five year olds in addition to offerings for all students within the district preschool-8th grade. This includes facilitating meetings with contracted providers in addition to organizing existing staff to meet the needs of families around extended care. Partnerships are being developed with the city of La Habra for services in addition to other organizations that can support expanded learning opportunities. The Early Learning Specialist (TOSA) has relationships with community partners and providers that have been developed over the last few years as part of the grant deliverables through First Five of Orange County, and she will facilitate all partners coming together in order to discuss the UPK plan and how they can be a part of helping us serve the community. LJSD will present the plan to the community at the regularly scheduled Board meeting on June 27th, 2022..

3. What actions does the LEA plan to take to partner with local R&Rs; LPCs; and existing early education, child care, and expanded learning providers within the LEA's attendance boundary to support parents to access services across LEA-administered and non-LEA-administered programs for extended learning and care and other supports?

LJSD currently works with the local R&R to provide early learning and expanded learning subsidized funding to our enrolled families. Our local R&R includes the Orange County Department of Education and Children's Home Society and Options for Learning (Whittier). We work with our R&R in order to recruit families that are in need of care. Our local R&R also gives us access to other existing providers in our area. LJSD will present the plan to the community in summer of 2022. Child Development Services will assist with the overall development and implementation of this. We have existing partnerships with Help Me Grow, the Vista Community Center, and the La Habra Collaborative in addition to work with First Five OC that all support opportunities for early learning as well as support for families around childcare, medical services, referrals, and parent training.

4. How does the LEA plan to create or grow partnerships with early learning and care providers serving children with disabilities (including how the LEA plans to collaborate with their SELPA to enroll more children with disabilities in inclusive UPK opportunities)?

LJSD is committed to engaging meaningful partnerships with early learning and care providers serving children with disabilities in the development of the UPK plan. We currently have protocols for enrolling students with disabilities into early childhood programs within the district. Both the program specialist working with special education services in the district and one of the teachers for the special education preschool were part of the committee developing the Universal PreKindergarten plan for the district to ensure thoughtful connections around inclusion and best practices for students with special needs. The Early Childhood Development team will assist with the overall implementation of the plan and continue to facilitate conversations with the Special Education Department as we focus on inclusive practices in the earliest ages for our students. The SELPA director (Special Education Local Plan Area) attends LCAP Advisory

Committee meetings to provide input into the LCAP and conducts regularly scheduled meetings as the North Orange County SELPA to discuss best practices, facilitate services across the SELPA, and support local districts with special education needs.

5. Develop sample program schedules that describe how the requirements of the ELO-P will be met for UPK, including the use of ELO-P funds or other fund sources; how they will be combined with the instructional day to offer a minimum of nine hours per day of programming (instructional day plus ELO-P or other supports); and how they will offer a minimum nine-hour summer or intersession day.

A nine hour day will be offered to all students that are enrolled in the LJSD TK program. Each child will attend a 5 hour TK class with a credentialed teacher and an aide.. Then, students will be offered before and after school options to create the nine hour day. LJSD has two different options for TK students for expanded learning opportunities. Transitional Kindergarten students will have the opportunity to enroll in the district's expanded learning program that offers before and after school enrichment and intervention. LJSD will use ELO-P funds for our UPP students to enroll in the before and after school program. Students that do not qualify for financial assistance will be able to enroll in our fee based expanded learning program.

Required Questions

CDE will be requiring this information be completed and submitted to the CDE after the plan is presented to the governing board.

1. Identify which of the following opportunities the LEA implemented to obtain public input on the UPK Plan. [Select all that apply]
 - a. **Parent Teacher Association Meetings**
 - b. **Family or parent surveys**
 - c. English Learner Advisory Committee (ELAC)
 - d. **District English Learner Advisory Committee (DELAC)**
 - e. **Special Education Local Plan Area (SELPA)**
 - f. School Site Council
 - g. District Advisory Committee
 - h. **LCAP educational partners input sessions**
 - i. Tribal Community input session
 - j. **Co-hosting events with community-based organizations (CBOs)**
 - k. Hosting meet and greets with the early learning and care community
 - l. LPC Meetings
 - m. Local Quality Counts California (QCC) consortia meetings
 - n. **First 5 County Commission meetings**
 - o. Community Advisory Committee (CAC)
 - p. Head Start Policy Council meetings
 - q. **Collaboration with parent engagement centers (for example, Parent Training and Information Center [PTIC], Community Parent Resource Center [CPRC], Family Empowerment Centers [FEC])**
 - r. **Other [describe, open response] built upon the Early Childhood Leadership Team to include 2 all day meetings to gather input around UPK from a diverse perspective**

2. Select which programs the LEA plans to combine with the TK instructional day to offer a minimum of nine hours per day of programming (instructional day plus programming) for children whose families opt in for extended learning and care. [select all that apply]
 - a. **Expanded learning programs on an LEA site (ASES, 21st Century Community Learning Centers [21st CCLC], ELO-P)**
 - b. Expanded learning programs at a CBO site (ASES, 21st CCLC, ELO-P)
 - c. **CSPP (on an LEA site)**
 - d. CSPP (at a CBO site)
 - e. **LEA- or locally-funded preschool**
 - f. Head Start
 - g. LEA preschool funded with Title I of the Every Student Succeeds Act funds
 - h. Other CBO preschool
 - i. **State subsidized child care (not including CSPP)**
 - j. **Other [describe, open response] (Fee Based)**

Focus Area C: Workforce Recruitment and Professional Learning

Based on the projected enrollment and needs described in Focus Area A, LEAs should create a plan to recruit, train, and support the new TK, preschool, early learning and care, and expanded learning staff needed to support full-day early education options for all children the year before kindergarten.

(Note: All LEAs will need to plan for workforce development considerations as part of this planning work. There is a separate \$100 million allocation for the Prekindergarten Planning and Implementation Grant – Competitive, also known as the Early Education Teacher Development Grant, that will be competitively awarded and is not part of this planning template.)

EC Section 48000(g)(4) specifies that credentialed teachers who are first assigned to a TK classroom after July 1, 2015, have, by August 1, 2023, one of the following:

- a. At least 24 units in early childhood education, or childhood development, or both.
- b. As determined by the LEA employing the teacher, professional experience in a classroom setting with preschool age children is comparable to the 24 units of education described in subparagraph (a).
- c. A Child Development Teacher Permit issued by the CTC.

EC Section 8295 specifies that teachers in CSPP shall either possess a permit issued by the CTC authorizing service in the care, development, and instruction of children in a child care and development program; or meet the following criteria:

- a. Possess a current credential issued by the CTC authorizing teaching service in elementary school or a single subject credential in home economics; and
- b. Possess twelve units in early childhood education or child development, or both, or two years' experience in early childhood education or a child care and development program.

Recommended Planning Questions

The CDE recommends LEAs prioritize these questions as part of their UPK Plan in addition to required questions below.

1. How does the LEA plan to recruit the educators needed to implement its UPK Plan (including CSPP teachers, assistant teachers, TK teachers, and TK teachers' instructional aides and assistants)?

LJSD currently has 6 TK classrooms across the school district and currently implements a Universal Transitional Kindergarten (UTK) program as part of services provided to support Universal Pre-kindergarten (UPK). All of the TK classrooms have fully qualified teachers. In addition, LJSD has applied for funds for the 2022 -2023 school year for 2 CSPP classrooms - all of which will have fully qualified teachers and assistants. LJSD works with the Human Resources team to recruit highly qualified teachers as well as mentor existing staff to gain qualifications for advancement. In addition, we are also a part of the Orange County Department of Education application for a workforce development grant through CDE. We have already hired a Site Supervisor for one of the preschools who has been on board for a few months to help us set everything up for the preschool programs. We have interviewed for the second Site Supervisor and the two Teachers who should be processed before the end of June. We are in the process of hiring the Instructional Aides for both the preschool and the TK classrooms and anticipate having those filled within the next few weeks. Information for these positions was posted on EdJoin and the district website as well as sent out through district communications, Twitter, and Facebook. The Coordinator for Early Childhood also distributed information to students in the early childhood programs at Cal State Fullerton.

2. How does the LEA plan to partner with CSPP, Head Start, and other early learning and care providers to offer joint professional learning opportunities?

LJSD has connections with early learning care providers in both Orange County and LA County. Staff of the Child Development Services team are part of multiple task forces within the surrounding community. The team is developing a cohesive group of child care providers to share information on the Early Developmental Index and Developmentally Appropriate Practices to then reflect on practices and determine professional development that will be available to all stakeholders that work within the collaborative. LJSD is committed to implementing a strong professional development plan that will include all early childhood education teachers - fee based, CSPP, certificated staff within the district, and community partners such as Head Start.

3. What is the LEA's planned strategy for providing professional learning for educators across the LEA's P-3 continuum? Plans might include the following: [open response]

- a. Who will receive this professional learning?
 - i. **By role (lead teachers, assistant teachers, administrators, coaches, and so forth)**
 - ii. **By grade (TK staff, kindergarten through third grade staff, on-site preschool staff, off-site preschool staff, and so forth)**
- b. What content will professional learning opportunities cover?
 - i. **Effective adult-child interactions**
 - ii. **Children's literacy and language development (aligned with the California Preschool Learning Foundations and the California Preschool Curriculum Frameworks)**

- iii. **Children’s developing math and science (aligned with the California Preschool Learning Foundations and the California Preschool Curriculum Frameworks)**
 - iv. **Children’s social-emotional development (aligned with the California Preschool Learning Foundations and the California Preschool Curriculum Frameworks)**
 - v. **Implicit bias and culturally- and linguistically-responsive practice**
 - vi. **Adverse Childhood Experiences (ACEs) and trauma- and healing-informed practice**
 - vii. **Curriculum selection and implementation**
 - viii. **Creating developmentally-informed environments**
 - ix. **Administration and use of child assessments to inform instruction**
 - x. **Support for multilingual learners, including home language development and strategies for a bilingual classroom**
 - xi. **Serving children with disabilities in inclusive settings, including Universal Design for Learning**
 - xii. **Engaging culturally- and linguistically-diverse families**
- c. How will professional learning be delivered?
- i. **Coaching and mentoring**
 - ii. **Classroom observations and demonstration lessons with colleagues**
 - iii. **Workshops with external professional development providers**
 - iv. **Internally-delivered professional learning workshops and trainings**
 - v. **Operating an induction program**
 - vi. **Partnerships with local QCC professional learning in CSPP settings**
 - vii. **In mixed groupings (for example, TK and CSPP teachers)**

4. How does the LEA plan to facilitate the development of a district early education leadership team (across grade levels and departments) and promote site-based horizontal and vertical articulation (P–3) teams to support student transitions, share strategies, and collaboratively monitor student progress?

LJSD currently facilitates and promotes site based horizontal and vertical articulation (P-3) to support student transitions, share strategies, and collaboratively monitor student progress. The Assistant Superintendent of Educational Services, the Director of Educational Services and the early learning education members work together to develop a plan each year. The Coordinator of Child Development Services also trains teachers on the development of children and to help with implementation of P-3 alignment.

Required Questions

CDE will be requiring this information to be completed after the plan is presented to the governing board.

1. Which of the following strategies does the LEA intend to use to support diverse and effective prospective TK teachers, including multilingual educators, to earn a Multiple Subject Teaching Credential? [select all that apply]

- A. Partner with one or more local Institutions of higher education (IHEs) or the COE to help support teachers holding less than a full credential to complete requirements to earn a preliminary Multiple Subject Teaching Credential

- B. Apply for a California Classified School Employee Teacher Credentialing Program grant (<https://www.ctc.ca.gov/educator-prep/grant-funded-programs/Classified-Sch-Empl-Teacher-Cred-Prog>) on your own, with your COE, as part of a new collaborative, or by joining an existing Classified grant program to recruit teachers
- C. Apply for a California Teacher Residency Grant Program (<https://www.ctc.ca.gov/educator-prep/grant-funded-programs/teacher-residency-grant-program>) on your own, as part of a new collaborative, or by joining an existing Teacher Residency Grant Program to recruit and prepare individuals with a bachelor's degree who want to become teachers in your LEA
- D. Join an existing intern preparation program to recruit and prepare teachers for your LEA
- E. Join an existing apprenticeship cohort program to recruit and prepare teachers for your LEA
- F. Establish a relationship with other local LEAs to establish pathways for high school students interested in a career in CSPP or in P-3 teaching through clubs, registered apprenticeships, or other such early recruitment opportunities
- G. Partner with the California Center on Careers to contact registrants who might be interested in becoming teachers for your LEA
- H. Provide information on scholarship and grant opportunities to CSPP and other staff interested in providing extended learning and care services
- I. Apply for workforce development funding and competitive grant opportunities from the CDE
- J. Provide a stipend for tuition and fees for coursework leading to a Multiple Subject Teaching Credential
- K. Provide advising on credential requirements and options for how to meet these requirements
- L. Collaborate with IHEs to offer unit-bearing coursework at a local LEA site during times that work for teachers and other interested staff members [list IHEs, open response]
- M. Partner with a local IHE to provide other services to candidates seeking to earn a Multiple Subject Teaching Credential
- N. Partner with a COE to provide other services to candidates seeking to earn a multiple subject credential
- O. Other [describe, open response]
- P. None of the above, the LEA currently has enough Multiple Subject Teaching Credential holders to meet the need for TK educators

2. Which of the following strategies does the LEA intend to employ to support diverse and effective prospective TK teachers, including multilingual educators, to meet the requirements under EC Section 48000(g)(4)? [select all that apply]

- a. Partner with a local IHE offering eligible early childhood education or childhood development coursework
- b. Partner with an IHE or COE to operate cohort models for LEA teachers earning 24 units
- c. Provide information on scholarship and grant opportunities
- d. Apply for workforce development funding and grant opportunities
- e. Provide a stipend for tuition, fees, and other programmatic costs associated with obtaining credit-based coursework or a degree
- f. Provide a stipend for tuition, fees, and other programmatic costs associated with obtaining a Child Development Teacher Permit
- g. Provide advising on requirements and how to meet the requirements
- h. Offer unit-bearing IHE coursework at a local LEA site during times that work for teachers
- i. Develop or work with an established mentorship program to support new TK teachers
- j. Other: Part of the OCDE Consortium for the Teacher Workforce Grant through CDE; the LEA currently has enough Multiple Subject teachers who have at least 24 units in early childhood education, or childhood development (or both) and/or they have professional experience in a classroom setting with preschool-age children that is comparable to the 24

units of education described in subparagraph (a); or a Child Development Teacher Permit issued by the CTC.

- k. None of the above
3. Which of the following strategies does the LEA intend to employ to support diverse and effective prospective CSPP teachers, including multilingual educators, to obtain a Child Development Teacher Permit [select all that apply]
 - a. Partner with a local IHE offering eligible early childhood education or childhood development coursework
 - b. Partner with an IHE or COE to operate cohort models for educators working towards a Child Development Teacher Permit
 - c. Provide information on scholarship and grant opportunities
 - d. Apply for workforce development funding and grant opportunities
 - e. Provide a stipend for tuition, fees, and other programmatic costs associated with obtaining credit-based coursework or a degree
 - f. Provide a stipend for tuition, fees, and other programmatic costs associated with obtaining a Child Development Teacher Permit
 - g. Provide advising on requirements and planning for how to meet the Child Development Teacher Permit requirements
 - h. Offer unit-bearing coursework at a local district site during times that work for teachers
 - i. Other: Part of the OCDE Consortium for the Teacher Workforce Grant through CDE; where feasible, the LEA may support prospective CSPP educators in obtaining a Child Development Teacher Permit and/or credential through programs offered through the county for classified employee development.
 - j. None of the above
 4. On which child observational assessments does the LEA intend to offer professional learning to TK, CSPP, and other early education teachers during the 2022–23 school year? [select all that apply]
 - a. Ages & Stages Questionnaire (ASQ)
 - b. BRIGANCE Early Childhood Screen
 - c. Desired Results Developmental Profile (DRDP)
 - d. Developmental Reading Assessment (DRA)
 - e. LEA-based, grade level benchmarks and a report card
 - f. Teaching Strategies GOLD (TS GOLD)
 - g. Work Sampling System (WSS)
 - h. Other [describe, open response]
 - i. The LEA does not plan to offer professional learning on child observational assessments
 5. On what topics does the LEA intend to offer professional learning regarding early childhood education to site leaders and principals? [select all that apply]
 - a. Effective adult-child interactions
 - b. Children's literacy and language development (aligned with the Preschool Learning Foundations and Frameworks)
 - c. Children's developing math and science (aligned with the California Preschool Learning Foundations and the California Preschool Curriculum Frameworks)
 - d. Children's social-emotional development (aligned with the California Preschool Learning Foundations and the California Preschool Curriculum Frameworks)
 - e. Implicit bias and culturally- and linguistically-responsive practice
 - f. ACEs and trauma- and healing-informed practice
 - g. Curriculum selection and implementation

- h. Creating developmentally-informed environments
- i. Administration and use of child assessments to inform instruction
- j. Support for multilingual learners, including home language development and strategies for a bilingual classroom
- k. Serving children with disabilities in inclusive settings, including Universal Design for Learning
- l. Engaging culturally- and linguistically-diverse families
- m. Other [describe, open response]
- n. Site leaders and principals will not be offered professional learning on early childhood education

Focus Area D: Curriculum, Instruction, and Assessment

It is critical for each LEA and preschool program partner to plan for how they will develop or select curriculum or curricula that are developmentally-informed and aligned with the strengths of all students, including multilingual students and students with disabilities, as well as how they will ensure curricula are implemented with fidelity to support intentional, quality instruction for all students. LEAs and preschool program partners should consider how they will provide coherent, culturally- and linguistically-responsive UPK curriculum or curricula anchored in the California Preschool Learning Foundations (<https://www.cde.ca.gov/sp/cd/re/psfoundations.asp>) and the California Preschool Curriculum Frameworks (<https://www.cde.ca.gov/sp/cd/re/psframework.asp>) to support the development of skills across the domains outlined in those documents.

Recommended Planning Questions

The CDE recommends LEAs prioritize these questions as part of their UPK Plan in addition to required questions.

1. Describe how the LEA will develop or select a curriculum for UPK classrooms that aligns with the California Preschool Learning Foundations and California Preschool Curriculum Frameworks.

LJSD's TK program implements a curriculum that aligns with the California Preschool Learning Foundations and the California Preschool Curriculum Frameworks. Other supplemental materials are purchased through LCAP funding when requested by teachers or the Early Learning Specialist. The committee that was convened for input on the UPK plan included 3 of the 5 TK teachers. They expressed a desire to revisit the current curriculum, so we will be examining options in the coming year as the program grows. We have also recently purchased new core materials for Spanish language development for the TK classes in the Dual Language Immersion program.

2. Describe the intended timeline for curriculum implementation, including steps for piloting and gathering input from UPK teachers, and a process for ensuring curriculum fidelity.

For the TK classrooms in the Dual Language Immersion program, materials were piloted in the spring of 2022 with Board approval in June. A UPK committee was convened in the spring of 2022 to gather input for the plan. As part of this committee, existing TK teachers were able to discuss thoughts on the existing curriculum. The current materials (Big Day TK from Houghton Mifflin) will no longer be supported by the publisher in terms of the digital platform and access. We will review materials in the 2022-23 school year to determine what new materials may need to be piloted and purchased for the TK program. The existing curriculum is still usable without the digital platform, so we will be determining if it still meets the needs of our students. Gathering input from TK teachers is an important part of our yearly practice. With preschool being new to the district, the Site Supervisor is facilitating the development of materials and purchase of resources in alignment with best practices outlined in the California Preschool Learning Foundations and California Preschool Curriculum Frameworks. Professional development opportunities will be provided for all TK and preschool teachers along with instructional support to ensure curriculum fidelity.

3. What actions does the LEA plan to take to support effective classroom organization practices and behavior management strategies to ensure a positive learning environment for a diverse population of UPK students?

LJSD is committed to support effective classroom organization practices and behavior management strategies to ensure a positive learning environment for a diverse population of UPK students. The district has an Early Learning TOSA (Teacher on Special Assignment) that works closely with every TK classroom and their staff. In addition, the Early Learning TOSA meets monthly with the Early Childhood Leadership Team. The Coordinator of Child Development Services will also train teachers on the development of children and to help implement developmentally appropriate strategies.

4. Describe how classroom practices for UPK (TK and other preschool programs the LEA operates or has on site) will be integrated and aligned.

Grade level meetings across the district are held regularly over the course of the school year. There will be specific meetings for discussion of P-3 alignment and training on best practices that will begin with preschool and TK-K teachers in the 2022-23 school year. Additional teachers from 1-3 will be invited and the group will be expanded over the coming years as we develop the full P-3 continuum within the district. Through a grant with First Five Orange County, the Early Developmental Instrument (EDI) is completed by Kindergarten teachers to determine student readiness for school. This data is shared with Educational Partners and discussions help to determine additional supports and professional development opportunities needed to support both families and staff.

5. What instructional practices does the LEA plan to implement to support children with disabilities in UPK (for example, implementing Universal Design for Learning, providing specialized services in the classroom with peer models, implementing social-emotional strategies such as the Pyramid Model)?

The Coordinator of Child Development Services will train teachers on the development of children and help implement developmentally appropriate strategies when working in a classroom setting. Some training will be offered before the start of the school year such as: Love and Logic, Special Education/SPED partnership, Universal Design for Learning, and the Pyramid Model. Professional development is also integrated in the monthly meetings between the Early Learning Specialist and the TK team.

6. What instructional practices does the LEA plan to implement to support the language and overall development of multilingual learners?

LJSD is committed to supporting the language and overall development of multilingual learners. ELD training is a part of the induction process and is accessible to all teachers. The Director of Educational Services is responsible for overseeing initial assessments for determining English learner status (initial ELPAC) and for monitoring all redesignated English learners with the support of four bilingual aides. Bilingual aides work with classroom teachers to ensure that both Designated ELD and INtegrated ELD are a part of the regular school day. Additional support are offered through before and after school opportunities, and a Boot Camp targeting language development is provided during the summer. All teachers are trained or will be trained in Project GLAD to support the development of language strategies within the classroom. The Early Learning Specialist (TOSA) is a certified trainer for Project GLAD and provides ongoing support and modeling within the classroom for implementation of best practices around support for English learners.

7. How does the LEA plan to assess dual language learners (DLLs) in areas other than English language acquisition?

LJSD uses Las Links to assess the language development of students within the DLI program as well as all English learners. This is in addition to information provided through district-wide benchmarks on iReady that include some limited spanish language assessments. The teachers within the DLI program also use assessments embedded within Benchmark Advance, the core program, to monitor student progress around standards and determine language proficiency.

Required Questions

CDE will be requiring this information to be completed after the plan is presented to the governing board.

1. Does the LEA plan to provide any of the following language model(s) for TK students?
[select all that apply]
 - a. Dual language program with a language allotment^[2] of 50/50 [open response for language offered]
 - b. Dual language program with a language allotment of 90/10 - Spanish
 - c. Dual language program with a language allotment of 80/20 [open response for language offered]
 - d. Dual language program with a language allotment of 70/30 [open response for language offered]
 - e. English-only instruction with home-language support

- f. None
 - g. Other
2. If the LEA administers CSPP, does it plan to provide any of the following language model(s) for CSPP students? [select all that apply]
- a. Dual language program with a language allotment^[3] of 50/50 [open response for language offered]
 - b. Dual language program with a language allotment of 90/10 [open response for language offered]
 - c. Dual language program with a language allotment of 80/20 [open response for language offered]
 - d. Dual language program with a language allotment of 70/30 [open response for language offered]
 - e. English-only instruction with home-language support
 - f. None
 - g. Other
3. Identify methods the LEA plans to use to support the development of social-emotional learning and executive function skills through specific instruction in these areas and by embedding and reinforcing this instruction in all curriculum areas. [select all that apply]
- a. Provide training for staff on the Center on the Social Emotional Foundations for Early Learning (CSEFEL) Pyramid Model
 - b. Implement the CSEFEL Pyramid Model in the classroom
 - c. Designing developmentally-appropriate learning environments to allow for individual and group activities that promote social-emotional learning and executive function skills (for example, use students' pictures or words in daily routines, feelings charts)
 - d. Promote learning through play as a context for social and emotional development, including social play with teachers and peers in small or large group settings
 - e. Use developmental observations to identify children's emerging skills and support their development through daily interactions
 - f. Development of lesson plans or use of a curriculum that includes specific and targeted social-emotional learning and executive function activities throughout the day of instruction
 - g. Staff development opportunities encouraging reflective practice and cross-level support for instruction specific to social-emotional learning and executive function skills
 - h. Offer open-ended, self-directed learning opportunities that foster individual interests and curiosity and new learning
4. What instructional practices does the LEA plan to implement to support children with disabilities in UPK programming? [select all that apply]
- a. Implement Universal Design for Learning
 - b. Provide adaptations to instructional materials
 - c. Provide specialized services (for example, occupational therapy, physiotherapy, speech and language pathology therapy) in the classroom with peer models
 - d. Implement social-emotional strategies, such as the Pyramid Model, CSEFEL, and others
 - e. Provide additional staff to support participation in instruction
 - f. Other
5. What assessments does the LEA plan to use in TK or kindergarten? [select all that apply]

- a. ASQ
- b. BRIGANCE Early Childhood Screen
- c. DRDP
- d. DRA
- e. LEA-based grade level benchmarks and a report card
- f. TS GOLD
- g. WSS
- h. Other: iReady; common benchmark assessment for Kindergarten administered four times a year.
- i. The LEA does not plan to use a common TK assessment
- j. Unsure

Focus Area E: LEA Facilities, Services, and Operations

It is critical to ensure that LEA facilities, services, and operations are thoughtfully aligned to support the implementation of UPK and movement towards a P-3 continuum. It is also critical for early education programs currently operating to continue to be a part of California's mixed-delivery system by creating shared space, blending funding and coordinating service delivery.

For Facilities:

For facilities planning, draw on the Projected Enrollment and Needs Assessment section of this document and the LEA's Facilities Master Plan. The objectives of this section are to identify the availability of space for UPK, the adequacy of available space to meet the kindergarten facilities standards for meeting the needs of young children, and, if needed, to update the Facilities Master Plan to address any unmet need for developmentally-appropriate space.

Recommended Planning Questions

The CDE recommends districts prioritize these questions as part of their UPK Plan in addition to required questions.

1. What strategies does the LEA plan to employ to integrate younger children and older children on the same campus and ensure safety and appropriate commingling?

LJSD already integrates younger and older children on the same campus and ensures safety and appropriate commingling through identified schedules for usage of space such as the playground. TK already exists at all sites, and two campuses will have preschool that will be integrated into their campus schedules. The TK is already accounted for in emergency planning outlined in the School Safety Plan, and the two sites with new preschools will add this information for the coming year.

To ensure safety, the Assistant Superintendent of Facilities and Operations looks at structural requirements and checks for issues while completing inspections regularly throughout the school year and for the FIT reports documented in the SARC for the site.

2. Describe how the LEA plans to address transportation issues resulting from UPK implementation. [open response]

LJSD does not provide transportation services outside of special education. Services provided through the Expanded Learning Opportunities program will be available at each of the five elementary sites as will child care options.

3. What strategies does the LEA intend to implement to ensure TK students have access to meals and adequate time to eat (for example, adding additional meal services and time in the cafeteria, offering breakfast after the bell [students pick up a breakfast and bring it to the classroom])? (Note: The LEA must continue to comply with all health and safety, state, and federal Child Nutrition Program regulations while implementing meal service) [open response]

TK already exists at all sites, and two campuses will have preschool that will be integrated into their campus schedules. Nutrition Services is a part of all conversations and is a part of the TK Leadership Team. To ensure regulations are being met, Nutrition Services completes inspections regularly throughout the school year. The department works closely with each school leadership team to ensure all students have access to meals and adequate time to eat by staggering schedules. Menu planning is also done in accordance with requirements for the various age spans.

Required Questions

CDE will be requiring this information to be completed after the plan is presented to the governing board.

1. To support an overall increase in UPK access, what efforts does the LEA plan to make to prevent the displacement of any early education programs on LEA campuses, including both LEA-administered and non-LEA-administered programs? [open response]

The Assistant Superintendent of Educational Services is on the district UPK planning team and is always included in conversations regarding classrooms and program placement. LJSD already has a TK classroom on every school district campus, so no existing early education programs are being displaced. With the addition of the two preschool sites, there was a Kindergarten teacher that was moved into a different space at one site next to the other Kindergarten classroom. The second site was undergoing some construction for a bond, so we were able to plan for a new classroom space for the preschool program without moving any existing teachers. Conversations with both Options and the Boys and Girls Club are being facilitated in order to determine space needs as the district is required to offer before and after school intervention and enrichment for UPP students. Options currently maintains a portable on 4 of our 5 elementary sites and the Boys and Girls Club uses space at the 5th site.

2. Does the LEA have adequate classroom space to meet the Projected Enrollment of TK students listed in the Projected Enrollment and Needs Assessment section of this document, for the respective implementation year? [multiple choice]

a. Yes

- b. No
 - i. If no, how many more classrooms does the LEA need? [identify number, open response]
 - ii. If no, how might the LEA provide classrooms in the timeframe needed? [describe, open response]
3. Does the space meet the kindergarten standards described in California Code of Regulations, Title 5, Section 14030(h)(2)? [multiple choice]
- a. Yes
 - b. No
 - i. If no, what modifications need to be made? What resources are needed to make them? (See Facilities Grant Program Funding at <https://www.dgs.ca.gov/OPSC/Services/Page-Content/Office-of-Public-School-Construction-Services-List-Folder/Access-Full-Day-Kindergarten-Facilities-Grant-Program-Funding>) [describe, open response]
4. Does the space contain necessary adaptive equipment, assistive technology, or other accommodations to ensure children with disabilities have access to education in the least restrictive environment? [multiple choice]
- a. Yes
 - b. No
 - i. If no, what modifications need to be made? What resources are needed to provide equipment or accommodations? [describe, open response]
5. Does the LEA's Facilities Master Plan adequately address the need for UPK programming? [multiple choice]
- a. Yes; the basic requirements are met with a desire to look at optimal space to provide programming as the need expands.
 - b. No
 - i. If no, what process will the LEA use to update the Facilities Master Plan to accommodate future TK and early education programming? [describe, open response]
6. In which of the following areas does the LEA intend to make updates to facilities? [select all that apply]
- a. Turfed area
 - b. Paved area
 - c. Apparatus area
 - d. Land required for buildings and grounds
 - e. Total square feet required
 - f. None of the above
7. What transportation will the LEA offer to children enrolled in TK? [select all that apply]
- a. Transportation to and from the TK program
 - b. Transportation from the TK program to an extended learning and care opportunity on another LEA site
 - c. Transportation from the TK program to an extended learning and care opportunity on a non-LEA site (for example, a CBO that operates a preschool program)
 - d. No transportation will be provided: programs will be offered at all elementary sites.

8. Will the LEA offer transportation to transport TK children to extended learning and care opportunities that are at other sites than the one the child is enrolled at for TK?

No, programs will be offered at all elementary sites.

^[1] The minimum length of instructional time that must be offered to constitute a school day is 180 minutes (EC sections 46117 and 46201). By statute, the maximum school day in kindergarten is four hours ("part day") (EC Section 46111). However, EC Section 8973 allows schools that have adopted an early primary program (extended-day kindergarten or "full day") to exceed four hours. Furthermore, EC Section 48000 states that a TK shall not be construed as a new program or higher-level service. In general, the number of required instructional minutes for TK is 36,000 minutes per year.

^[2] The percentage of instructional time spent on the target language and English (e.g., in a 50/50 Spanish/English program, 50% of instructional time is spent on each language).

^[3] The percentage of instructional time spent on the target language and English (e.g., in a 50/50 Spanish/English program, 50% of instructional time is spent on each language).

EXPANDED LEARNING OPPORTUNITIES

Lowell Joint School District
11019 Valley Home Ave.
Whittier, CA 90603



**Lowell Joint
School District**

A Tradition of Excellence Since 1906

**This Program Plan Template is required by California *Education Code (EC)*
Section 46120(b)(2)**

Name of Local Educational Agency and Expanded Learning Opportunities Program Site(s)

Local Educational Agency (LEA) Name: Lowell Joint School District

Contact Name: Mary Brimmage

Contact Email: mbrimmage@ljsd.org

Contact Phone: 562-902-4270

Instructions: Please list the school sites that your LEA selected to operate the Expanded Learning Opportunities Program (ELO-P). Add additional rows as needed.

1. El Portal
2. Jordan
3. Macy
4. Meadow Green
5. Olita
6. Rancho Starbuck Intermediate (as space and funding allows)
7. _____
8. _____

Purpose

This template will aid LEAs in the development of a program plan as required by *EC* Section 46120(b)(2). In this program plan, LEAs will describe program activities that support the whole child, and students' Social and Emotional Learning (SEL) and development.

Definitions

"Expanded learning" means before school, after school, summer, or intersession learning programs that focus on developing the academic, social, emotional, and physical needs and interests of pupils through hands-on, engaging learning experiences. It is the intent of the Legislature that expanded learning programs are

pupil-centered, results driven, include community partners, and complement, but do not replicate, learning activities in the regular school day and school year. (*EC* Section 8482.1[a])

“Expanded learning opportunities” has the same meaning as “expanded learning” as defined in *EC* Section 8482.1. “Expanded learning opportunities” does not mean an extension of instructional time, but rather, opportunities to engage pupils in enrichment, play, nutrition, and other developmentally appropriate activities. (*EC* Section 46120[e][1])

Instructions

This Program Plan needs to be approved by the LEA’s Governing Board in a public meeting and posted on the LEA’s website.

The program plan template guide is considered a living document that is periodically reviewed and adjusted to reflect the needs of the community, updates in the law, and to provide continuous improvement in the development of an effective ELO-P.

The LEA is responsible for creating, reviewing, and updating the program plan every three years in accordance with *EC* Section 8482.3(g)(1). LEAs are encouraged to work collaboratively with partners and staff to develop and review the program plan. The LEA is responsible for the plan and the oversight of any community partners or subcontractors. The LEA should include any partners in the development and review of the plan. It is recommended that the plan be reviewed annually.

The Expanded Learning Division adopted the *Quality Standards for Expanded Learning in California* (Quality Standards) and introduced requirements for Continuous Quality Improvement (CQI) to help programs engage in reflection and be intentional about program management practices and activities delivered to students. To create the program plan, provide a narrative description in response to the prompts listed under each Quality Standard below. The LEA may customize and include additional prompts, such as describing SEL activities, or refining the plan. In addition to the narrative response, it may be useful to include tables, charts, or other visual representations that contribute to the understanding of the ELO-P. LEAs are encouraged to download and reference the Quality Standards in order to provide ongoing improvements to the program. The Quality Standards can be found on the California Department of Education’s (CDE) Quality Standards and CQI web page, located at <https://www.cde.ca.gov/ls/ex/qualstandcqi.asp>.

1—Safe and Supportive Environment

Describe how the program will provide opportunities for students to experience a safe and supportive environment. Include if the program will be offered on the school site or off campus. If not on site, describe where in the community it will be and how students will be supported to get there.

The program will be offered at each of the elementary sites to begin with the potential for Rancho should funds and availability allow, so transportation is not an issue. Existing arrangements with Options and Boys and Girl Club include either space on campus or transportation provided off site by the organization. A staff program manual will be created to outline processes and procedures to ensure things run smoothly. This will include Daily Safety Procedures, where critical student information is available such as medical, custody, authorized persons, and samples of forms such as incident reports. Procedures for attendance will be outlined as well. Class locations and schedules will be communicated with all staff and parents. The program will include behavior expectations in line with those followed during the regular school day and programming will support the development of character education also consistent with the regular school program. Training for staff will include safety and first aid, information on building trust and creating a nurturing environment, and on all processes and procedures outlined in the manual. Staff will wear IDs to ensure visibility and accessibility for both students and families.

2—Active and Engaged Learning

Describe how the program will provide opportunities for students to experience active and engaged learning that either supports or supplements, but does not duplicate, the instructional day.

The focus of the Expanded Learning Program includes opportunities for both intervention and enrichment to support learning during the school day. STEAM activities will be coordinated to supplement grade level curriculum offered within the day as will theater arts, music, physical education, robotics and other offerings that may be available on a limited basis otherwise. Intervention components will include access to current iReady data and supplemental lessons not covered during day. Staff will continue to provide before and after tutoring to targeted students based on identified needs. Student input on offerings for enrichment will be critical to connect students with learning of high interest, and we will look for opportunities for students to showcase their learning from these sessions. This might be some kind of an Open House for parents to see student work or a performance for example. Communication with classroom teachers will also be facilitated for input for needed interventions and homework/tutor that will support student progress in core subjects during the day. The program will be evaluated at the end of each session by staff, families, and students to determine if adjustments need to be made.

3—Skill Building

Describe how the program will provide opportunities for students to experience skill building.

Learning goals for class session will be determined ahead of time with clearly defined objectives, connections to standards (whether academic, technology, or even social emotional), and outcomes for growth. The goal would be to develop a culminating activity to showcase student learning that is driven, in part, by input from students. Integration of leadership skills, 21st Century skills, and LJSD citizenship/patriotism will be an important part of the development of these sessions for before and after school. There will be opportunities provided for both intervention and enrichment that are designed to support skills in all aspects of growth monitored under our Multi-Tiered System of Supports (MTSS)-academic, behavior, and social emotional.

4—Youth Voice and Leadership

Describe how the program will provide opportunities for students to engage in youth voice and leadership.

Staff training will include information on providing leadership opportunities as well as gathering input from students for offerings. Staff will be encouraged to look for opportunities to hand over leadership to students where appropriate. One suggestion includes using older students to support the transition of younger students from the regular day to the after school programs. This might include helping out at the tables while students eat the snack provided before sessions begin. The Coordinator for Expanded Learning is building systems for student input and voice in developing programs based on interest and need so that learning experiences within classes will be student driven.

5—Healthy Choices and Behaviors

Describe how the program will provide opportunities for students to engage in healthy choices and behaviors. Describe how students will be served nutritious meals and/or snacks during the ELO-P hours of programming.

Close coordination with food services for snacks and any meals needed for required standards for snacks will be facilitated by the Coordinator for Expanded Learning. The behavior system and expectations for each site will be communicated to both students and parents as well as staff to ensure connectedness with expectations during the regular school day. This includes discussion of character education as a foundation for making good choices. Regular communication with parents for positive behaviors will set the foundation for when discipline issues occur and need to be managed. Professional development for staff to will include information on the

character education program so that it can be integrated into offerings to support healthy choices.

6—Diversity, Access, and Equity

Describe how the program is designed to address cultural and linguistic diversity and provide opportunities for all students to experience diversity, access, and equity. Describe how the ELO-P will provide access and opportunity for students with disabilities.

Efforts to recruit and hire staff that reflect the diverse community within the boundaries of Lowell Joint is always a priority. This includes the hiring of more bilingual staff to support the growing needs of the community in this area as well as a focus on language development needs such as the building of academic vocabulary through both enrichment and intervention opportunities for example. Curriculum will reflect cultural and linguistic diversity and again, offerings will be driven by input from students and families. Since the district does not qualify for other funding programs like ASES, the Expanded Learning Opportunity program is significantly increasing access to students for both enrichment and intervention beyond the school day. Where sites might offer 4-6 formal art lessons a year in partnership with the Muckenthaler, for example, students interested in art will be able to continue that learning on offerings after school that they would otherwise not have access to. Training for staff will include support for working with culturally and linguistically diverse students. The Director of Special Education has been a part of planning conversations for the integration of students with special needs into the Expanded Learning Opportunities program. For many students, the needs can be addressed through training of staff to ensure appropriate accommodations for students to access programming. If a student has a one-on-one aide during the day, that support would be provided for before and/or after school offerings as well. Based on input from staff, students, and families, the Coordinator of Expanded Learning and the Director of Special Education will continue to monitor participation and engagement to make adjustments as needed.

7—Quality Staff

Describe how the program will provide opportunities for students to engage with quality staff.

Lowell Joint is dedicated to hiring high quality staff to best serve our students during the regular school day and this will continue for the Expanded Learning Opportunities program. Staff will be recruited based on experience and skill set. Special attention will be given to maintaining quality experiences utilizing existing staff leads for direction and input as well as experts in the fields of choice. Many of the staff for ELO-P will be existing certificated and classified employees within the district in addition to existing partnerships with outside organizations. All new staff will be hired in accordance with current practices to ensure quality. Having a positive attitude, integrity, and modeling the character traits taught and modeled to students in the

regular program are an important aspect for all Lowell Joint employees. The Coordinator of Expanded Learning Opportunities will regularly monitor staff and provide feedback on performance.

8—Clear Vision, Mission, and Purpose

Describe the program’s clear vision, mission, and purpose.

The Lowell Joint School District is committed to providing a strong academic program of 21st Century Skills with a well-rounded program of diverse and innovative subject offerings. All schools emphasize the importance of education, the family, and traditional values. We stress the value of personal integrity, social responsibility, and a respect for our national heritage. The Lowell Joint School District envisions a culture where technology empowers all members of the school community to achieve success and expand learning beyond the walls of the classroom. All stakeholders will utilize technology to become highly competent in a technological world through continuous improvement in academics, career, and life. ELO-P will focus on both intervention and enrichment with the “Studio” providing extended care for families needing longer hours of child care. This will allow access for students that have had to have other arrangements for child care historically. Students can participate in opportunities available through ELO-P and then if necessary, have additional child care through the Studio. All of this is designed to meet the needs of families based on input and feedback as we design the program options.

9—Collaborative Partnerships

Describe the program’s collaborative partnerships. Local educational agencies are encouraged to collaborate with non-LEA entities to administer and implement ELO-P programs.

Currently, the district works with both Options and the Boys and Girls Club for before and after school care. Both are generating proposals for support of Expanded Learning Opportunities in addition to other partnerships that the district is exploring. Contacts have been made with YMCA afterschool programs, the Muckenthaler, RMH Dance Company, DMIS teaching artists, various existing LJSD classified/certificated staff interested in offering intervention and enrichment, Coach Tigran (sports fitness & international dance), and musician contacts through Cameron Miller. As we get input from students and families on what offerings they would like to see, we will formalize partnerships and/or explore additional staffing options to meet those needs.

10—Continuous Quality Improvement

Describe the program’s Continuous Quality Improvement plan.

The Coordinators for Expanded Learning Opportunities and Early Childhood will evaluate program quality on a regular basis to determine if offerings for both intervention and enrichment are meeting the needs of students and families. This will include observations of program quality including staffing, surveys of students, staff, community, and vendors after sessions with open ended suggestions available, monitoring individual school data in terms of both participation and progress on goals for both the program and the regular school day using progress on iReady, and similar input for intersession days in the summer. Because this is the beginning of the program, there will be a need to monitor and adjust more frequently in the opening months. The district anticipates adding offerings based on student interest and need after the initial sessions for the fall have been evaluated. Ongoing conversations with families will be facilitated and logs maintained for both participation and usage of child care to determine adjustments to the program that may be necessary.

11—Program Management

Describe the plan for program management.

The Coordinators for Expanded Learning Opportunities and Early Childhood (for TK and Kinder) will work together to oversee the program. This includes opportunities at regularly scheduled Instructional Cabinet meetings to share program elements and get input from support personnel from all departments including the Directors, the Assistant Superintendents, the Superintendent, and Principals. The Coordinators will work with the Assistant Superintendent of Educational Services to ensure compliance with Expanded Learning Opportunities requirements and plan implementation. An Office Manager and Fiscal Clerk have also been hired to support the Expanded Learning Opportunities and Universal Pre-Kindergarten programs to ensure staff dedicated to the successful implementation of these two new programs for the district.

General Questions

Existing After School Education and Safety (ASES) and 21st Community Learning Centers (21st CCLC) Elementary and Middle School grantees.

ASES, 21st CCLC Elementary/Middle School, and the ELO-P should be considered a single, comprehensive program. In coordinating all these funding streams to move towards a single program, the expectation is that the most stringent requirements will be adopted for program guidance. If one or both grants are held, please describe how the ELO-P funding will be used to create one comprehensive and universal Expanded Learning Program.

Lowell Joint does not receive funding for either ASES or 21st Century CCLC. As such, the Expanded Learning Opportunities Program will allow for much needed supports for our students. We currently provide before and after school intervention at each site on a small scale. This will be moved under the ELO-P Coordinator as part of intervention offerings to ensure cohesiveness.

Transitional Kindergarten and Kindergarten

Programs serving transitional kindergarten or kindergarten pupils shall maintain a pupil- to-staff member ratio of no more than 10 to 1. (*EC Section 46120[b][2][D]*). Please address the proposed schedule and plan for recruiting and preparing staff to work in the program, including supporting them to understand how to work with younger children. How will the lower pupil-to-staff ratio be maintained? How will the curriculum and program be developmentally-informed to address this younger age group?

As part of the district's overall Universal Pre-kindergarten plan, there will be two preschools opened for the 2022-23 school year in addition to the existing preschool for students with special needs. The ratio requirements for preschool are 8 to 1 and will be staffed accordingly. For those students transitioning into offerings for Expanded Learning from Transitional Kindergarten and Kindergarten classrooms the 10 to 1 ratio will be maintained. This will include existing staff in offering after school opportunities, community partnerships, and additional support personnel hired to support the overall program. Job descriptions have been drafted and some of the initial hiring has taken place. This will continue throughout the summer and school year as the program needs for staffing continue to be adjusted. The Early Childhood Coordinator is overseeing opportunities for our youngest learners in connection with ELO-P. He will continue to organize and facilitate trainings for all staff on developmentally appropriate practices as part of our overall Universal Pre-Kindergarten program and P-3 alignment. This will include support for any contractors who are not a part of professional development plans within the district as a whole.

Sample Program Schedule

Please submit a sample program schedule that describes how the ELO-P or other fund sources, including the California State Preschool Program for children enrolled in transitional kindergarten or kindergarten, will be combined with the instructional day to create a minimum of nine hours per day of programming (instructional day plus ELO-P or other supports). Also, submit a sample schedule for a minimum nine-hour summer or intersession day.

7:30-8:30 Various interventions per site as well as enrichment for TK and Kindergarten including staggered sessions for late & early bird. This includes options for 7:30-9:30 for late birds and options from 1:30-3:00 for early birds until additional programming begins at 3:15 after snack.

3:00-3:15 Snack
3:15-4:05 Enrichment and intervention session #1
4:05-4:15 Transition between sessions
4:15-5:00 Potential Enrichment and intervention session #2

Additional child care opportunities may be available based on family need to extend hours until 6 pm.

Our current intersession schedule:

8:00-12:00 Certificated staff from within the District are providing thematic learning activities designed to build skills through hands-on, engaging activities that support standards

12:00-1:00 Lunch for those students staying for the afternoon sessions.

1:00-5:00 City of La Habra is providing Expanded Learning Opportunities:

A variety of classes will be offered including, but not limited to, art lessons, outdoor physical activity, performing arts, cooking and more.

The City of La Habra will provide daily activities in an outdoor camp setting:

- Specialty Instructor for each Station
- Supplies needed for each class
- Activity Calendar/Schedule
- Water
- Snacks
- At least one on-site supervisor each day

Specialty stations may include, but are not limited to:

Cooking Experience (No stove/oven required); Martial Arts; Dance (Modern, Cheer, Folklorico); Musical Theatre; Field Games; Sports (Soccer, Basketball, Volleyball); LHPD; Science; Art; Water Fun Days; Nature; Virtual Field Trips to Around the World (Learning about different places and cultures)

Below are additional legal requirements for the ELO-P. Please ensure your Program Plan meets all of these legal requirements:

EC Section 46120(b)(2):

[LEAs] operating expanded learning opportunities programs may operate a before school component of a program, an after school component of a program, or both the before and after school components of a program, on one or multiple school sites, and shall comply with subdivisions (c), (d), and (g) of Section 8482.3, including the development of a program plan based on the following;

(2) [LEAs] operating expanded learning opportunity programs pursuant to this section may operate a before school component of a program, an after school component of a program, or both the before and after school components of a program, on one or multiple school sites, and shall comply with subdivisions (c), (d), and (g) of Section 8482.3, including the development of a program plan based on all of the following:

(A) The department's guidance.

(B) Section 8482.6.

(C) Paragraphs (1) to (9), inclusive, and paragraph (12) of subdivision (c) of Section 8483.3.

(D) Section 8483.4, except that programs serving transitional kindergarten or kindergarten pupils shall maintain a pupil-to-staff member ratio of no more than 10 to 1.

EC Section 46120(b)(1)(A):

On schooldays, as described in Section 46100 and Sections 46110 to 46119, inclusive, and days on which school is taught for the purpose of meeting the 175-instructional-day offering as described in Section 11960 of Title 5 of the California Code of Regulations, in-person before or after school expanded learning opportunities that, when added to daily instructional minutes, are no less than nine hours of combined instructional time and expanded learning opportunities per instructional day.

EC Section 46120(b)(1)(B):

For at least 30 non-schooldays, during intersessional periods, no less than nine hours of in-person expanded learning opportunities per day.

EC Section 46120(b)(3):

[LEAs] shall prioritize services provided pursuant to this section at school sites in the lowest income communities, as determined by prior year percentages of pupils eligible for free and reduced-price meals, while maximizing the number of schools and neighborhoods with expanded learning opportunities programs across their attendance area.

EC Section 46120(b)(4):

[LEAs] may serve all pupils, including elementary, middle, and secondary school pupils, in expanded learning opportunity programs provided pursuant to this section.

EC Section 46120(b)(6):

[LEAs] are encouraged to collaborate with community-based organizations and childcare providers, especially those participating in state or federally subsidized childcare programs, to maximize the number of expanded learning opportunities programs offered across their attendance areas.

EC Section 46120(c):

A [LEA] shall be subject to the audit conducted pursuant to Section 41020 to determine compliance with subdivision (b).

EC Section 8482.3(d):

[LEAs] shall agree that snacks made available through a program shall conform to the nutrition standards in Article 2.5 (commencing with Section 49430) of Chapter 9 of Part 27 of Division 4 of Title 2.

[LEAs] shall agree that meals made available through a program shall conform to the nutrition standards of the United States Department of Agriculture's at-risk afterschool meal component of the Child and Adult Care Food Program (42 United States Code [U.S.C.] Section 1766).

EC Section 8482.6:

Every pupil attending a school operating a program . . . is eligible to participate in the program, subject to program capacity. A program established . . . may charge family fees. Programs that charge family fees shall waive the cost of these fees for pupils who are eligible for free or reduced-price meals, for a child that is a homeless youth, as defined by the federal McKinney-Vento Homeless Assistance Act (42 U.S.C. Section 11434a), or for a child who the program knows is in foster care. A program

that charges family fees shall schedule fees on a sliding scale that considers family income and ability to pay.

EC sections 8483.4 and 46120(b)(2)(D):

The administrator of every program established pursuant to this article shall establish minimum qualifications for each staff position that, at a minimum, ensure that all staff members who directly supervise pupils meet the minimum qualifications for an instructional aide, pursuant to the policies of the school district. Selection of the program site supervisors shall be subject to the approval of the school site principal. The administrator shall also ensure that the program maintains a pupil-to-staff member ratio of no more than 20 to 1. All program staff and volunteers shall be subject to the health screening and fingerprint clearance requirements in current law and district policy for school personnel and volunteers in the school district, except that programs serving transitional kindergarten or kindergarten pupils shall maintain a pupil-to-staff member ratio of no more than 10 to 1.

EC Section 8482.3(c)(1)(A–B):

Each component of a program established pursuant to this article shall consist of the following two elements:

(A) An educational and literacy element in which tutoring or homework assistance is provided in one or more of the following areas: language arts, mathematics, history and social science, computer training, or science.

(B) An educational enrichment element that may include, but need not be limited to, fine arts, career technical education, recreation, physical fitness, and prevention activities.

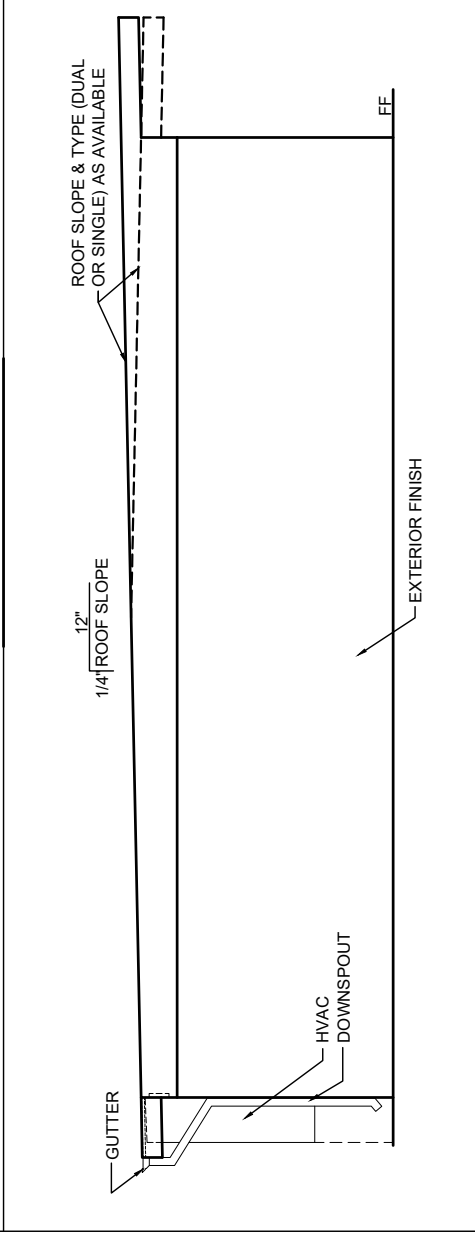
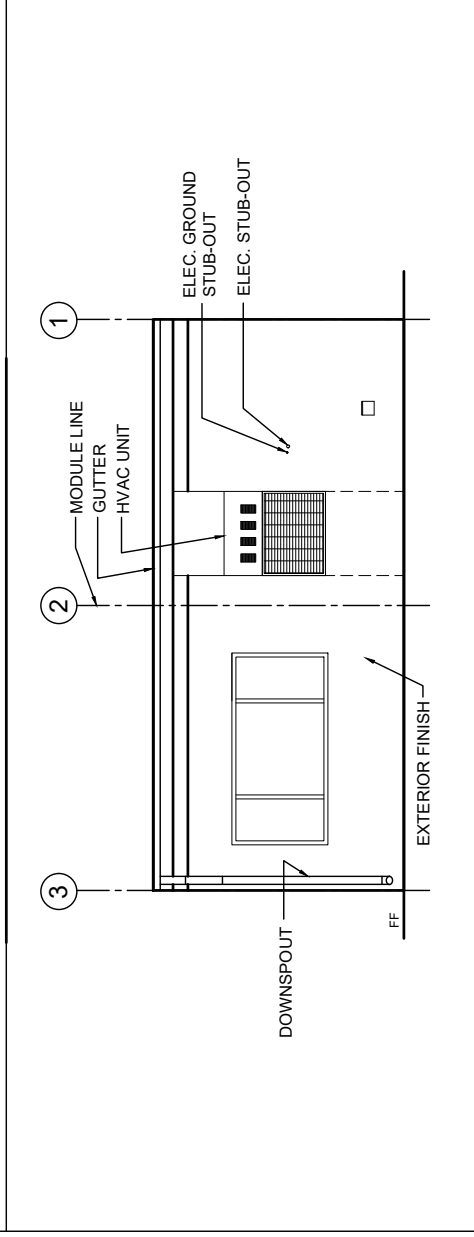
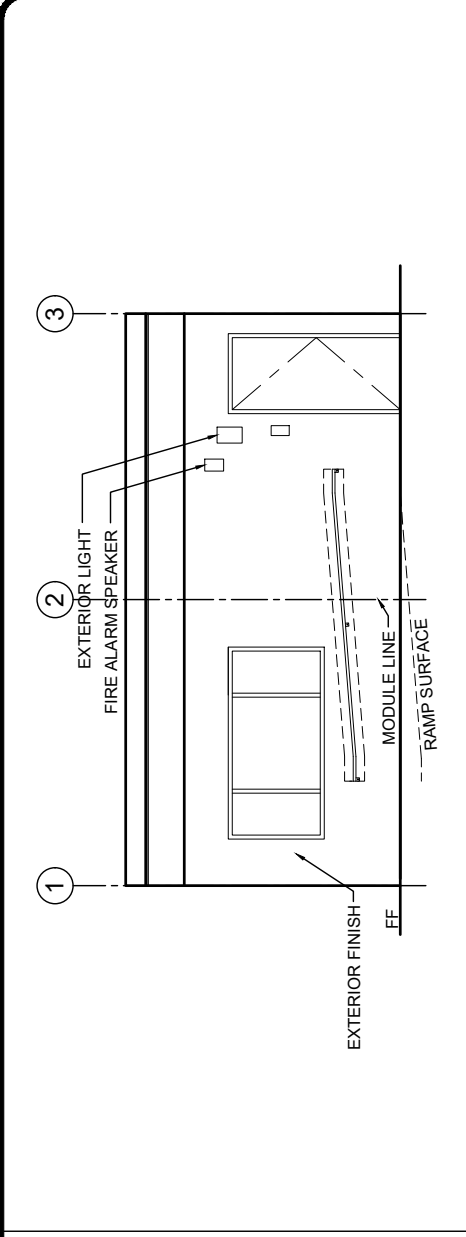
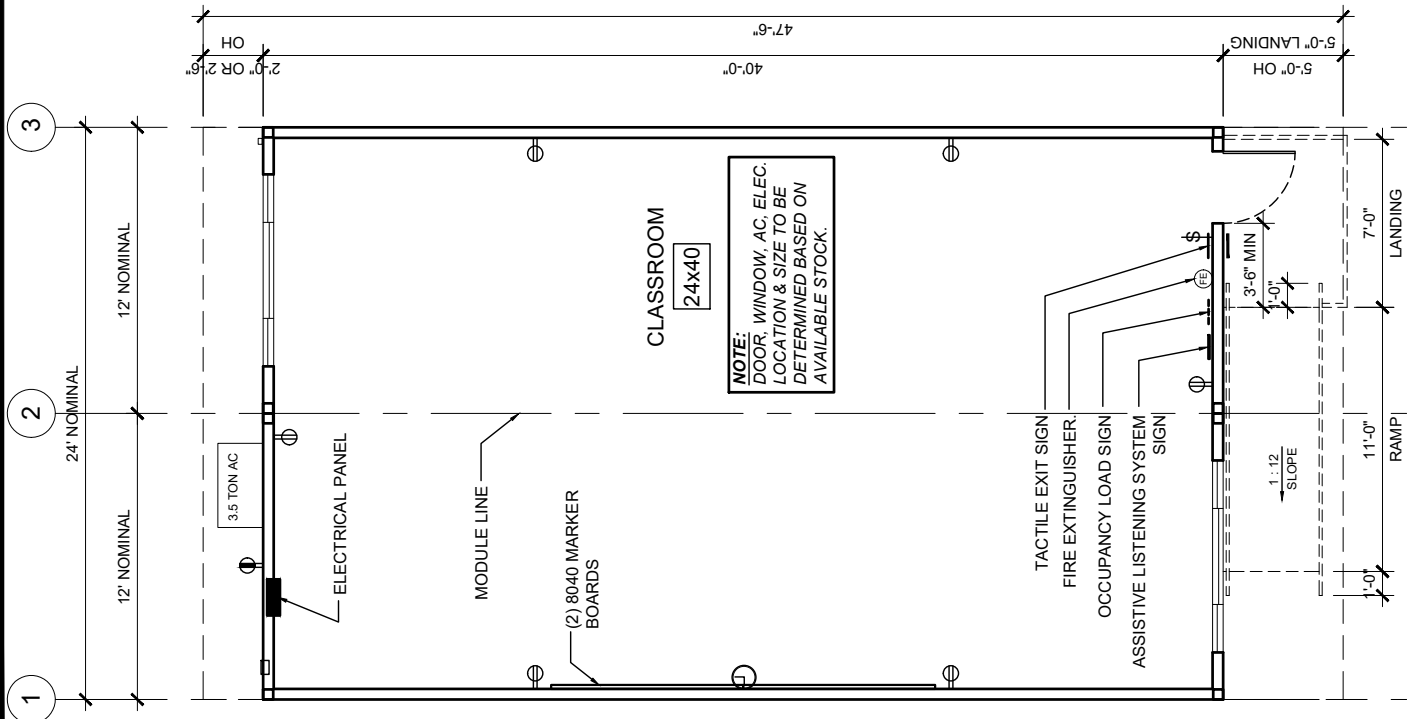

MODEL "A" 24x40 REFURBISHED CLASSROOM

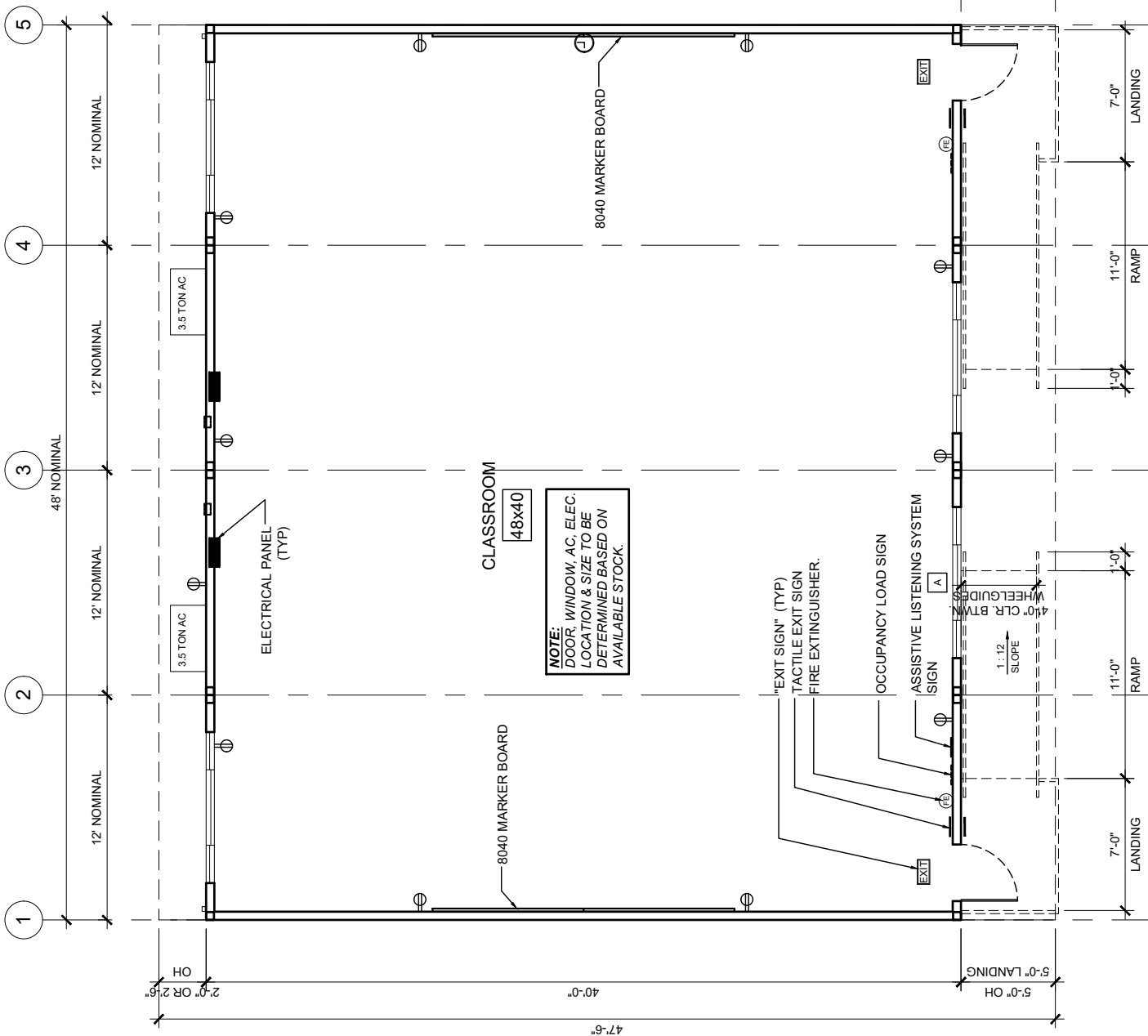

NOTE:
 DOOR, WINDOW, AC, ELEC.
 LOCATION & SIZE TO BE
 DETERMINED BASED ON
 AVAILABLE STOCK.

MODEL "C" 48x40 REFURBISHED CLASSROOM (FLOOR PLAN)



advisors
Schoohaus

1818 W. Chapman Avenue, #G, Orange, CA 92868

project
manual

Project

2021 District-Wide Contract for the Purchase, Lease, Relocation, Dismantling, and Removal of Division of the State Architect (DSA) Approved Portable Buildings

Project: SSPU, #40-04/2020-21

Issued: November 27, 2020

Bid Date: December 11, 2020 8:00am

Bid Location: Savanna School District Main Office
1330 S. Knott Avenue
Anaheim, CA 92804



Savanna School District

1330 S. Knott Ave., Anaheim 92804 • 714) 236-3800

Savanna School District

1330 SOUTH KNOTT AVENUE
ANAHEIM, CALIFORNIA 92804-4798
PHONE: (714) 236-3800

LETTER OF AWARD

February 10, 2021

Jeremy Goldenetz, President
Elite Modular Leasing & Sales, Inc.
P.O. Box 78447
Corona, CA 92877

Re: 2021 District-Wide Contract for Purchase, Lease, Dismantling, and Removal of Division of the State (DSA) Approved Portable Buildings, Project SSPU, #40-04/2020-21, Master Agreement

Dear Mr. Goldenetz,

We are pleased to inform you that the Award of a Master Agreement for the 2021 District-Wide Contract for Purchase, Lease, Dismantling, and Removal of Division of the State (DSA) Approved Portable Buildings, Project SSPU, #40-04/2020-21, was approved by the Board of Trustees on February 9, 2021.

A copy of the executed Master Agreement will be sent to you under separate cover shortly. Please forward the following items to Cindy Leighton at Schoolhaus Advisors: 1818 W. Chapman Ave, Suite G, Orange, CA 92868 as soon as possible:

- 1) Worker's Compensation Insurance/Certificate
- 2) Certificates of Liability Insurance (Comprehensive General, Auto, etc.) in accordance with the contract requirements.

This is not an approval to proceed with any work at this time. In accordance with the terms of your Master Agreement, a purchase order must be issued for each project initiated under this contract. When a project is initiated, other required contract documents such as bonds (if included in the project scope), criminal records check forms, drug-free work place forms, etc. will be required to be fully executed and submitted. Please coordinate with Jim Harris for on-going project needs. We look forward to working with you on our upcoming projects.

Sincerely,



Dr. Sue Johnson
Superintendent

cc: Eric Fano, SSD
Jim Harris, SSD
Lynne Pentecost, Schoolhaus Advisors

DR. SUE JOHNSON
SUPERINTENDENT

Savanna School District

1330 SOUTH KNOTT AVENUE
ANAHEIM, CALIFORNIA 92804-4798
PHONE: (714) 236-3800

January 19, 2022

Jeremy Goldenetz, President
Elite Modular Leasing & Sales, Inc.
P.O. Box 78447
Corona, CA 92877

Re: Approval of Annual Renewal of the 2021 District-Wide Contract for the Purchase, Lease, Relocation, Dismantling, and Removal of Division of the State Architect (DSA) approved Portable Buildings, Project SSPU, #40-04/2020-21

Dear Mr. Goldenetz,

We are pleased to inform you that the one year renewal of your existing 2021 District-Wide Contract for the Purchase, Lease, Relocation, Dismantling, and Removal of Division of the State Architect (DSA) approved Portable Buildings, Master Contract (originally awarded February 9, 2021,) was approved by the Board of Trustees on January 11, 2022, including a 4.9% CPI increase. This renewal will allow projects to be awarded/contracted through February 8, 2023.

This is not an approval to proceed with any work. In accordance with the terms of your Master Agreement, a purchase order must be issued for each project initiated under this contract. Please continue to coordinate with Jim Harris for on-going project needs. We look forward to working with you on our upcoming projects.

Sincerely,



Dr. Sue Johnson
Superintendent

cc: Eric Fano, SSD
Lynne Pentecost, Schoolhaus Advisors

SAVANNA SCHOOL DISTRICT
BOARD OF TRUSTEES
MINUTES – REGULAR MEETING
FEBRUARY 9, 2021

The meeting was called to order by the President, Mrs. Tina Karanick, at 4:06 p.m. in the District Administration Office.

Members Present: Mrs. Tina Karanick, President
Mrs. Chris Brown, Vice President
Mrs. Linda Weinstock, Clerk
Mr. John Shook, Member

Member Absent: Mr. Edward Erdtsieck, Member

Motion by Mrs. Weinstock, seconded by Mrs. Brown, to adopt the agenda was carried 4-0.

Flag salute and invocation were led by Mrs. Weinstock.

There were no public comments regarding closed session items.

Motion by Mrs. Brown, seconded by Mr. Shook, was submitted to adjourn to closed session to consider matters pursuant to Government Code §54957; personnel; negotiations; matters pursuant to Government Code §54956.9: existing and anticipated litigation; and consider other matters announced by the Board of Trustees or Superintendent. The motion was carried 4-0.

Meeting adjourned to Closed Session at 4:10 p.m.

Closed session adjourned at 4:37 p.m.

No action taken during closed session. There was nothing to report out.

Meeting reconvened into Open Session at 4:39 p.m.

Members Present: Mrs. Tina Karanick, President
Mrs. Chris Brown, Vice President
Mrs. Linda Weinstock, Clerk
Mr. John Shook, Member

Member Absent: Mr. Edward Erdtsieck, Member

Meeting Protocols were read by Mrs. Karanick.

There were no public comments.

Superintendent Report was presented by Dr. Johnson, as follows:

- 1) Out and About in the Community.
- 2) New freezer installed in warehouse.
- 3) Lunch structure covers have arrived to be installed.
- 4) Return to in-person learning scheduled for March 8, 2021.
- 5) Catalyst kids open at 3 of our 4 schools.

Motion by Mrs. Brown, seconded by Mr. Shook, to authorize and approve the consent agenda as follows:

Board meeting minutes.

Personnel action on file in the District Office.

Check numbers 31189 through 31287.

Purchase Order numbers P52R2590 through P52R2733.

Revolving Cash Fund check numbers 1621 through 1625.

The motion was carried 4-0.

Motion by Mrs. Weinstock, seconded by Mrs. Brown, to approve the project, and direct staff to file a Notice of Completion for M.P. South for the 2020 Expanded Walk-in Freezer Project, #40-03d/2020-21, based on the 2015 Maintenance/ Construction Unit Price Bid (UPB) Master Agreement. The motion was carried 4-0.

Motion by Mr. Shook, seconded by Mrs. Weinstock, to award a Master Agreement, to Elite Modular Leasing & Sales, Inc., for the 2021 District-Wide Contract for Purchase, Lease, Dismantling, and Removal of Division of the State Architect (DSA) Approved Portable Buildings, Project SSPU, #40-04/2020-21, for one year, renewable for a period of up to five years. The motion was carried 4-0.

Motion by Mrs. Brown, seconded by Mrs. Weinstock, to approve the 2020 E-rate Year Wide Area Network Digital Transmission Services Master Agreement with Spectrum. The motion was carried 4-0.

Motion by Mr. Shook, seconded by Mrs. Brown, to approve the School Accountability Report Card, School Plan for Student Achievement, School Safety Plan for Cerritos, Hansen, Holder and Reid Schools. The motion was carried 4-0.

Motion by Mrs. Weinstock, seconded by Mrs. Brown, to approve the proposed school year calendars for 2021-22, 2022-23, 2023-24, and 2024-25. The motion was carried 4-0.

Motion by Mrs. Brown, seconded by Ms. Shook, to adopt and/or approve updated Board Policies and Administrative Regulations as submitted by California School Boards Association. The motion was carried 4-0.

Information was presented regarding the funds that are invested by the Office of the Orange County Treasurer-Tax Collector for the Educational Investment Pool.

Board took a break from 5:49 p.m. to 5:57 p.m.

Motion by Mrs. Brown, seconded by Mr. Shook, to adjourn to closed session was carried 4-0.

The meeting adjourned to Closed Session at 5:58 p.m.

Meeting reconvened into Open Session at 6:12 p.m.

Motion by Mrs. Weinstock, seconded by Mr. Shook, to adjourn meeting was carried 4-0.

Meeting adjourned at 6:13 p.m.

Secretary

AGREEMENT

THIS AGREEMENT, dated the 9th day of February, 2021, in the County of Orange, State of California, is by and between Savanna School District, (hereinafter referred to as "DISTRICT"), and Elite Modular Leasing & Sales, Inc., (hereinafter referred to as "CONTRACTOR").

The DISTRICT and the CONTRACTOR, for the consideration stated herein, agree as follows:

1. CONTRACTOR agrees to complete the Project known as 2021 District-Wide Contract for the Purchase, Lease, Relocate, Dismantling, and Removal of Division of the State (DSA) Approved Portable Buildings, Project No. SSPU, #40-04/2020-21 according to all the terms and conditions set forth in the Project Documents, including but not limited to the Notice Calling For Bids, Information for Bidders, Bid Form 1, Bid Form-2 including all attachments, Bid Security, Designation of Subcontractors, Information Required of Bidder, Noncollusion Affidavit, Workers' Compensation Certificate, Faithful Performance Bond, Payment Bond, Disabled Veterans Business Enterprise (DVBE) Certification, Escrow Agreement, if applicable, Drug-Free Workplace Certification, Criminal Records Check Certification, Change Orders, Shop Drawing Transmittals, Contractors Inspection Request Form, Insurance Certificates and Endorsements, Guarantees, Contractor's Certificate Regarding Non-Asbestos Containing Materials, Tobacco Free Workplace Certification, Lead-Containing Materials and Notice Certification, General Conditions, Supplementary General Conditions, Drawings, Specifications, and all modifications, addenda and amendments thereto by this reference incorporated herein. The Project Documents are complementary, and what is called for by any one shall be as binding as if called for by all.

2. CONTRACTOR shall perform within the time set forth in Paragraph 4 of this Agreement everything required to be performed, and shall provide, furnish and pay for all the labor, materials, necessary tools, expendable equipment, and all taxes, utility and transportation services required for construction of the Project. All of said work shall be performed and completed in a good workmanlike manner in strict accordance with the drawings, specifications and all provisions of this Agreement as hereinabove defined and in accordance with applicable laws, codes, regulations, ordinances and any other legal requirements governing the Project. The CONTRACTOR shall be liable to the DISTRICT for any damages arising as a result of a failure to fully comply with this obligation, and the CONTRACTOR shall not be excused with respect to any failure to so comply by any act or omission of the District or Program Manager, or representative of any of them, unless such act or omission actually prevents the CONTRACTOR from fully complying with the requirements of the Project Documents, and unless the CONTRACTOR protests at the time of such alleged prevention that the act or omission is preventing the CONTRACTOR from fully complying with the Project Documents. Such protest shall not be effective unless reduced to writing and filed with the DISTRICT within three (3) working days of the date of occurrence of the act or omission preventing the CONTRACTOR from fully complying with the Project Documents.

3. DISTRICT shall pay to the CONTRACTOR, as full consideration for the faithful performance of this Agreement , subject to any additions or deductions as provided in the Project Documents, number of dollars agreed upon (based on the unit prices) between the Owner and Contractor for each individual project/purchase order activated under this unit price agreement. The

cost shall be documented on a specific individual project quotation form, and in the actual purchase order.

4. The work shall be commenced on or before the First (1st) day after receiving the DISTRICT'S Notice to Proceed and shall be completed within the number of consecutive calendar days (including punch list items) from the date specified in the Notice to Proceed, negotiated between the Owner and Contractor in Accordance with the terms of Article 5 of the Information for Bidders, Project Schedule, for each project activated under this unit price agreement. The timeline shall be documented in each and every purchase order executed against this agreement.

5. **Time is of the essence.** If the work is not completed in accordance with Paragraph 4 above, it is understood that the DISTRICT will suffer damage. It being impractical and infeasible to determine the amount of actual damage, in accordance with Government Code Section 53069.85, it is agreed that CONTRACTOR shall pay to DISTRICT as fixed and liquidated damages, and not as a penalty, the sum of Five-hundred Dollars (\$500.00) for each calendar day of delay until work is completed and accepted. Time extensions may be granted by the DISTRICT as provided in Article 61 of the General Conditions. Liquidated damages shall be imposed as set forth in Article 61 of the General Conditions.

6. **Termination for Cause or Nonappropriation.** In the event CONTRACTOR defaults in the performance of the Agreement as set forth in General Conditions Article 13(a) or if there is a nonappropriation of funds or insufficient funds as set forth in General Conditions Article 13(d), then this Agreement shall terminate or be suspended as set forth in General Conditions Article 13.

7. **Termination for Convenience.** DISTRICT has discretion to terminate this Agreement at any time and require CONTRACTOR to cease all work on the Project by providing CONTRACTOR written notice of termination specifying the desired date of termination. Upon receipt of written notice from DISTRICT of such termination for DISTRICT's convenience, CONTRACTOR shall:

- (i) Cease operations as directed by DISTRICT in the notice;
- (ii) Take any actions necessary, or that DISTRICT may direct, for the protection and preservation of the work; and
- (iii) Not terminate any insurance provisions required by the Project Documents.

In case of such termination for DISTRICT's convenience, CONTRACTOR shall be entitled to receive payment from DISTRICT for work satisfactorily executed and for proven loss with respect to materials, equipment, and tools, including overhead and profit for that portion of the work completed. In the case of Termination for Convenience, DISTRICT shall have the right to accept assignment of subcontractors. The foregoing provisions are in addition to and not in limitation of any other rights or remedies available to the DISTRICT.

8. The CONTRACTOR agrees to and does hereby indemnify and hold harmless the DISTRICT, its Governing Board, officers, agents, and employees from every claim or demand made, and every liability, loss, damage, or expense, of any nature whatsoever, which may be incurred by reason of:

(a) Any injury to or death of any person(s) or damage to, loss or theft of any property sustained by the CONTRACTOR or any person, firm or corporation employed by the CONTRACTOR, either directly or by independent contract, upon or in connection with the work called for in this AGREEMENT, except for liability resulting from the sole active negligence, or willful misconduct of the DISTRICT.

(b) Any injury to or death of any person(s) or damage, loss or theft of any property caused by any act, neglect, default or omission of the CONTRACTOR, or any person, firm, or corporation employed by the CONTRACTOR, either directly or by independent contract, arising out of, or in any way connected with the work covered by this Agreement, whether said injury or damage occurs either on or off DISTRICT property, if the liability arose due to the negligence or willful misconduct of anyone employed by the CONTRACTOR, either directly or by independent contract,

The CONTRACTOR, at CONTRACTOR'S own expense, cost, and risk shall defend any and all actions, suits, or other proceedings that may be brought or instituted against the DISTRICT, its Governing Board, officers, agents or employees, on any such claim, demand or liability, and shall pay or satisfy any judgment that may be rendered against the DISTRICT, its Governing Board, officers, agents or employees in any action, suit or other proceedings as a result thereof.

9. Hold Harmless and Indemnification. To the fullest extent permitted by law, the CONTRACTOR, at the CONTRACTOR's sole cost and expense, agrees to fully defend, indemnify and hold harmless, the DISTRICT, including but not limited to any of its governing board members, officers, employees and agents, from and against any and all claims, actions, demands, costs, judgments, liens, penalties, liabilities, damages, losses, anticipated losses of revenues, and expenses, including any fees of accountants, attorneys or other professionals, arising out of, in connection with, resulting from or related to, or claimed to be arising out of, in connection with, resulting from or related to any act or omission by the CONTRACTOR or any of its officers, agents, employees, subcontractors, sub-subcontractors, any person performing any of the work pursuant to a direct or indirect contract with the CONTRACTOR or individual entities comprising the CONTRACTOR, in connection with or relating to, or claimed to be in connection with or relating to the work, this Agreement, or the Project, including but not limited to any costs or liabilities arising out of or in connection with:

- (a) failure to comply with any applicable law, statute, code, ordinance, regulation, permit or orders;
- (b) any misrepresentation, misstatement or omission with respect to any statement made in the Project Documents or any document furnished by the CONTRACTOR in connection therewith;
- (c) any breach of duty, obligation or requirement under the Project Documents;
- (d) any failure to coordinate the work of other contractors;
- (e) any failure to provide notice to any party as required under the Project Documents;
- (f) any failure to act in such a manner as to protect the DISTRICT and the Project from loss, cost, expense or liability; or
- (g) any failure to protect the property of any utility company or property owner.

This indemnity shall survive termination of the contract or final payment thereunder. This indemnity is in addition to any other rights or remedies which the DISTRICT may have under the law or under the Project Documents. In the event of any claim or demand made against any party which is entitled to be indemnified hereunder, the DISTRICT may in its sole discretion reserve, retain or apply any monies due to the CONTRACTOR under the Project Documents for the purpose of resolving such claims; provided, however, that the DISTRICT may release such funds if the CONTRACTOR provides the DISTRICT with reasonable assurance of protection of the DISTRICT's interests. The DISTRICT shall in its sole discretion determine whether such assurances are reasonable.

10. CONTRACTOR shall take out, prior to commencing the work, and maintain, during the life of this Agreement, and shall require all subcontractors, if any, whether primary or secondary, to take out and maintain the insurance coverages set forth below and in Article 16 of the General Conditions. CONTRACTOR agrees to provide all evidences of coverage required by DISTRICT including certificates of insurance and endorsements.

	Combined Single Limit
Commercial General Liability	\$1,000,000 per occurrence/\$2,000,000 aggregate for bodily injury, personal injury and property damage
Automobile Liability	\$1,000,000 per occurrence for bodily injury and property damage
Employer's Liability	\$1,000,000 per occurrence
Builder's Risk	To be negotiated for each individual purchase order initiated under this Master Agreement

11. Public Contract Code Section 22300 permits the substitution of securities for any retention monies withheld by the DISTRICT to ensure performance under this Agreement. At the request and expense of the CONTRACTOR, securities equivalent to the monies withheld shall be deposited with the DISTRICT, or with a state or federally chartered bank in California as the escrow agent, who shall then pay such monies to the CONTRACTOR. The DISTRICT retains the sole discretion to approve the bank selected by the CONTRACTOR to serve as escrow agent. Upon satisfactory completion of the Agreement, the securities shall be returned to the CONTRACTOR. Securities eligible for investment shall include those listed in Government Code Section 16430 or bank or savings and loan certificates of deposit. The CONTRACTOR shall be the beneficial owner of any securities substituted for monies withheld and shall receive any interest thereon.

In the alternative, under Section 22300, the CONTRACTOR may request DISTRICT to make payment of earned retention monies directly to the escrow agent at the expense of the CONTRACTOR. Also at the CONTRACTOR's expense, the CONTRACTOR may direct investment of the payments into securities, and the CONTRACTOR shall receive interest earned on such investment upon the same conditions as provided for securities deposited by CONTRACTOR. Upon satisfactory completion of the Agreement, CONTRACTOR shall receive from the escrow agent all securities, interest and payments received by escrow agent from DISTRICT pursuant to the terms of Section 22300.

12. If CONTRACTOR is a corporation, the undersigned hereby represents and warrants that the corporation is duly incorporated and in good standing in the State of California, and that Jeremy Goldenetz, whose title is President, is authorized to act for and bind the corporation.

13. Each and every provision of law and clause required by law to be inserted in this Agreement shall be deemed to be inserted herein and the Agreement shall be read and enforced as though it were included herein, and if through mistake or otherwise any such provision is not inserted, or is not currently inserted, then upon application of either party the Agreement shall forthwith be physically amended to make such insertion or correction.

14. This Agreement constitutes the entire agreement of the parties. No other agreements, oral or written, pertaining to the work to be performed, exists between the parties. This Agreement can be modified only by an amendment in writing, signed by both parties and pursuant to action of the Governing Board of the District. This Agreement shall be governed by the laws of the State of California.

15. Piggybacking. To the extent the Contractor is required to, or otherwise agrees to, permit "piggybacking" on the Contract by public agencies as described in the Instructions For Bidders, the District shall have no liability whatsoever in connection with any orders submitted to the Contractor by such other public agencies and, in each case, any and all liabilities associated with a piggyback order shall be the sole responsibility of the Contractor and/or the public agency that submitted the order to the Contractor. The Contractor acknowledges that certain of the services required by the Contract constitute a public project or public work in accordance with applicable law and that other public agencies may not be authorized by applicable law to piggyback on the Contract in order to obtain such services. In each such case, the Contractor shall reasonably endeavor to advise the public agency accordingly. To the extent required pursuant to Section 8.15 of the General Provisions, the Contractor shall indemnify, defend and hold-harmless the District, the Governing Board and each member thereof, and the District's other officers, employees, or agents (each, not including the District, a "District Agent") with respect to any and all liabilities that arise from the piggybacking on the Contract by any public agency.

- (a) Contracts with Other Agencies/Rights to Order: Other public school DISTRICTS, community college DISTRICTs, and public agencies throughout the State of California including, but not necessarily limited to the attached list (Attachment #1), may lease or purchase identical items at the same unit price(s) subject to the same terms and conditions, pursuant to Sections 20118 and 20652 of the Public Contract Code. Savanna School District waives its right to require other DISTRICTs to draw their warrants in favor of the DISTRICT and authorizes each DISTRICT/agency to make payments directly to the successful bidder.

16. Assignment. Contractor shall not assign, sublet or by any other means transfer the Contract or any obligation, right, title or interest herein, including right to payments hereunder, without the prior written consent of District. The Contract shall be binding on any authorized assignee, sublessee, transferee or other successor to the Contractor. If Contractor attempts, without District permission, to assign, sublet or by any other means transfer the Contract or any obligation, right, title or interest herein, the District may, at its option, terminate the Contract and shall thereafter

be relieved from any and all obligations to Contractor and any purported assignee, sublessee or transferee.

IN WITNESS WHEREOF, the parties hereto have caused this Agreement to be executed.

SAVANNA SCHOOL DISTRICT

By: 
Signature

Dr. Sue Johnson
Print Name

Superintendent
Title

CONTRACTOR

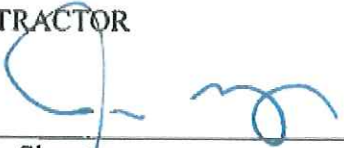
By: 
Signature

Jeremy Goldenetz
Print Name

President
Title

1020113
Contractor's License No.

81-3842215
Tax ID/Social Security No.

jeremy@elitemodular.net
Email

951-422-2500
Telephone

(CORPORATE SEAL OF CONTRACTOR,
if corporation)

NOTICE CALLING FOR BIDS

District: Savanna School District

Bid Deadline: Date: Friday, December 11, 2020 Time: 8:00am

District Office: 1330 S. Knott Avenue, Anaheim, CA 92804

Project: 2021 District-wide Unit Price Contract for the Purchase, Lease, Relocation, Dismantling and Removal of Division of the State Architect (DSA) Approved Portable Buildings, Project SSPU, #40-04/2020-21

NOTICE IS HEREBY GIVEN that the Savanna School District of Orange County, California, acting by and through its Governing Board, hereinafter referred to as "DISTRICT," will receive up to, but not later than, the above-stated bid deadline, sealed bids at the District Office for the award of a contract for the above Project.

There will be a mandatory pre-bid conference at 8:00am on Monday, December 7, 2020 at the District Office. Any bidder failing to attend the entire conference will be deemed a nonresponsive bidder and will have its bid returned unopened.

Contract Documents will be available in electronic format only beginning Friday, November 27, 2020, via transmission of an emailed link. Please contact Cindy Leighton at Cindy@schoolhausinc.com for a copy of the complete Project Manual.

In accordance with the provisions of Business and Professions Code Section 7028.15 and Public Contract Code Section 3300, the DISTRICT requires that the bidder possess the following classification(s) of contractor's license(s) at the time the bid is submitted: Class B. Any bidder not so licensed at the time of the bid opening will be rejected as nonresponsive. Further note that in accordance with SB 854 that the Prime Bidder and all listed sub-contractors must be registered with the Department of Industrial Relations, pursuant to Labor Code Section 1725.5, and will be required to participate in DIR's compliance monitoring and enforcement program.

Each bid shall be accompanied by a bid security in the form of cash, a certified or cashier's check or bid bond in an amount not less than \$100,000 (One-hundred-thousand dollars) payable to the DISTRICT.

The DISTRICT reserves the right to reject any or all bids or to waive any irregularities or informalities in any bids or in the bidding process. As part of the bid submittal, the District is asking the bidders to submit a completed schedule of unit prices for various items that may or may not be included in various individual projects initiated over the course of the contract. The method to determine the lowest bid will be to insert each bidder's unit prices into a sample project created by the Project Manager. A copy of the sample project quantity take offs will be supplied to all who attend the public bid opening: after the bid submittal deadline, but before bids are opened.

The California Department of Industrial Relations has determined the general prevailing rates of per diem wages for the locality in which the work is to be performed for the Project. Copies of these wage rate determinations, entitled Prevailing Wage Scale, are available at the following website: www.dir.ca.gov. It shall be mandatory upon the successful bidder to whom the contract is awarded, and upon any subcontractor listed, to pay not less than the said specified rates to all workers employed by them for the Project. Certified Payroll records will be submitted to both the District and the DIR during the course of the work, and work will be subject to monitoring by the DIR.

No bidder may withdraw any bid for a period of ninety (90) calendar days after the date set for the opening of bids.

Pursuant to Public Contract Code Section 22300, the Agreement will contain provisions permitting the successful bidder to substitute securities for any monies withheld by the DISTRICT to ensure performance under the Agreement or permitting payment of retentions earned directly into escrow.

Publication: Anaheim Bulletin, November 26 and December 3, 2020
Challenge News, November 30 - December 4, 2020 □

Anaheim Bulletin

2190 S. Towne Centre Place Suite 100
Anaheim, CA 92806
714-796-2209

PROOF OF PUBLICATION

Legal No. **0011425351**

5204241

SCHOOL HAUSIN, INC.
1818 W. CHAPMAN AVE., STE 6
ORANGE, CA 92868

FILE NO. NCB DW Portable Lease-Purch-Relc

AFFIDAVIT OF PUBLICATION

STATE OF CALIFORNIA, }
County of Orange } **SS.**

I am a citizen of the United States and a resident of the County aforesaid; I am over the age of eighteen years, and not a party to or interested in the above-entitled matter. I am the principal clerk of the Anaheim Bulletin, a newspaper that has been adjudged to be a newspaper of general circulation by the Superior Court of the County of Orange, State of California, on December 28, 1951, Case No. A-21021 in and for the City of Anaheim, County of Orange, State of California; that the notice, of which the annexed is a true printed copy, has been published in each regular and entire issue of said newspaper and not in any supplement thereof on the following dates, to wit:

11/26/2020, 12/03/2020

I certify (or declare) under the penalty of perjury under the laws of the State of California that the foregoing is true and correct:

Executed at Anaheim, Orange County, California, on
Date: December 03, 2020.



Signature

NOTICE CALLING FOR BIDS

District: Savanna School District

Bid Deadline: Date: Friday, December 11, 2020 Time: 8:00am

District Office: 1330 S. Knott Avenue, Anaheim, CA 92804

Project: 2021 District-wide Unit Price Contract for the Purchase, Lease, Relocation, Dismantling and Removal of Division of the State Architect (DSA) Approved Portable Buildings, Project SSPU, #40-04/2020-21

NOTICE IS HEREBY GIVEN that the Savanna School District of Orange County, California, acting by and through its Governing Board, hereinafter referred to as "DISTRICT," will receive up to, but not later than, the abovestated bid deadline, sealed bids at the District Office for the award of a contract for the above Project.

There will be a mandatory pre-bid conference at 8:00am on Monday, December 7, 2020 at the District Office. Any bidder failing to attend the entire conference will be deemed a nonresponsive bidder and will have its bid returned unopened.

Contract Documents will be available in electronic format only beginning Friday, November 27, 2020, via transmission of an emailed link. Please contact Cindy Leighton at Cindy@schoolhausinc.com for a copy of the complete Project Manual.

In accordance with the provisions of Business and Professions Code Section 7028.15 and Public Contract Code Section 3300, the DISTRICT requires that the bidder possess the following classification(s) of contractor's license(s) at the time the bid is submitted: Class B. Any bidder not so licensed at the time of the bid opening will be rejected as nonresponsive. Further note that in accordance with SB 854 that the Prime Bidder and all listed subcontractors must be registered with the Department of Industrial Relations, pursuant to Labor Code Section 1725.5, and will be required to participate in DIR's compliance monitoring and enforcement program.

Each bid shall be accompanied by a bid security in the form of cash, a certified or cashier's check or bid bond in an amount not less than \$100,000 (One-hundred-thousand dollars) payable to the DISTRICT.

The DISTRICT reserves the right to reject any or all bids or to waive any irregularities or informalities in any bids or in the bidding process. As part of the bid submittal, the District is asking the bidders to submit a completed schedule of unit prices for various items that may or may not be included in various individual projects initiated over the course of the contract. The method to determine the lowest bid will be to insert each bidder's unit prices into a sample project created by the Project Manager. A copy of the sample project quantity take offs will be supplied to all who attend the public bid opening: after the bid submittal deadline, but before bids are opened.

The California Department of Industrial Relations has determined the general prevailing rates of per diem wages for the locality in which the work is to be performed for the Project. Copies of these wage rate determinations, entitled Prevailing Wage Scale, are available at the following website: www.dir.ca.gov. It shall be mandatory upon the successful bidder to whom the contract is awarded, and upon any subcontractor listed, to pay not less than the said specified rates to all workers employed by them for the Project. Certified Payroll records will be submitted to both the District and the DIR during the course of the work, and work will be subject to monitoring by the DIR.

No bidder may withdraw any bid for a period of ninety (90) calendar days after the date set for the opening of bids.

Pursuant to Public Contract Code Section 22300, the Agreement will contain provisions permitting the successful bidder to substitute securities for any monies withheld by the DISTRICT to ensure performance under the Agreement or permitting payment of retentions earned directly into escrow.

Publication: Anaheim Bulletin, November 26 and December 3, 2020
Challenge News, November 30 - December 4, 2020 11425351

SUB-BIDS ARE REQUESTED FROM QUALIFIED DVBE Subcontractors & Suppliers for the following:

District-Wide Unit Price Contract for Purchase/Lease/Relocation of Portable Buildings
Proj No: SSPU #40-04/2020-21
Bid Date: December 11, 2020 @ 8:00 a.m.
Location: Various Sites
Lic. Type: B
Contact: Cindy Leighton
Company: Savanna School District
Address: 1330 S. Knott Avenue
 Anaheim, CA. 92804
Tel: 714-532-1352

30113015

SUB-BIDS REQUESTED FROM QUALIFIED SBE/MBE/WBE/DBE/DVBE Subcontractors and Suppliers for the following project(s):

Lovell High School Building Trades for Cutler-Orosi Joint Unified School District, in Cutler, CA
Location: 12724 Avenue 392, Cutler, CA 93615
Requested Trades for Bid: All Trades
Bid Date: Wednesday, December 2, 2020
Bid Time: 10:00 AM
 Submit Bids to bids@forcummackey.com or via Fax at (559) 798-1412.
Company: Forcum/Mackey Construction, Inc.
Address: 15695 Jasmine Avenue
 Ivanhoe, CA 93235
Tel: (559) 798-1837 **Fax:** (559) 798-1412

30111720

WE ARE REQUESTING BIDS FROM QUALIFIED DVBE for the following projects:

Beaumont USD
Bid Date: December 1, 2020
Location: Beaumont, CA
Est. Cost: \$2,000,000.00
Duration: 19 Months
Chaffey Joint Union HS District
Bid Date: December 3, 2020
Location: Etiwanda, CA
Est. Cost: \$940,000
Duration: 343 Days
Desert Sands USD
Bid Date: December 10, 2020
Location: Palm Desert, CA
Est. Cost: \$1,700,000.00
Duration: 585 Days
Lic. Type: C-10
Contact: Estimating Department
Company: R.I.S. Electrical Contractors, Inc.
Address: 7330 Sycamore Canyon Blvd, Suite 1
 Riverside, CA 92508
Tel: (951) 653-2611 **Fax:** (951) 653-5611

30112310

The Office of Small Business and DVBE Services

is committed to supporting California small business and disabled veteran businesses.

During this challenging time, our office is extending the certifications for expiring certified firms starting in September, 2020, so our customers can focus on their health and wellbeing. If you have any questions, contact us at

**OSDSHelp@dgs.ca.gov or
 (916) 375-4940.**

BUILD GROUP, INC. IS REQUESTING subcontractor bids from all Certified / Qualified DVBE subcontractors' and material suppliers for the following project:

SFUSD - MCATEER WORLD MUSIC ROOM MODERNIZATION
Bid Date & Time: 12/07/20 at 12:00pm PST
Scope of Work: The Project is generally described as: Music Rooms Modernization including, but not limited to, hazardous materials abatement, the installation of acoustical wall panels & new acoustical ceiling tiles, electrical work, relocation of all necessary building systems; clock, receptacles, switches, air diffusers and fire alarm devices.
Email: estimatingpw@buildgc.com
Fax: 415-366-1883
Contact: William Reuvekamp at 925-818-6937 if you have any questions
 Please email ALL bids and questions to estimatingpw@buildgc.com

30111940

CONSTRUCTION CONTRACTING OPPORTUNITY
 for Contractors, Subcontractors, Suppliers
 Los Angeles County Sanitation Districts Invite Bids For The Construction of:
 San Jose Creek Water Reclamation Plant Stage Two Process Air Distribution Upgrades (Bid Opening December 15, 2020 - Estimate \$4,500,000 - \$6,000,000)
Contracting And Supply Opportunities Include:
 Demolition; Aluminum Grating; Fiberglass Panels; Stainless Steel Platforms
 Los Angeles County Sanitation Districts encourage participation of minority, women, disadvantaged, disabled veterans, and small business enterprises. Plans and Specifications may be obtained through Quest Construction Data Network (QuestCDN) for a nonrefundable fee of \$15.00. This can be done via a link on the Districts' Listing of Advertised Construction Projects webpage
<https://www.lacsd.org/opportunities/bidspur/constri ds.asp> or by inputting Quest project number 7350714 through the QuestCDN website (www.questcdn.com).
 Visit our Web site at "www.lacsd.org" and click on "Opportunities, Construction Bids"

CNS-3408986#

SUB-BIDS REQUESTED FROM QUALIFIED SBE/MBE/WBE/DBE/DVBE Subcontractors and Suppliers for the following projects:

New Metal Building for Transportation for Lindsay Unified School District in Lindsay, CA
Location for project: 250 N. Harvard Avenue, Lindsay, CA 93247
Requested Trades for Bid: All trades
Bid Date: Tuesday, December 8, 2020
Bid Time: 3:00 PM
Sheriff and Fire Dispatch Center for County of Tulare Capital Projects, in Visalia, CA
Location for project: 5300 W. Tulare Avenue, Visalia, CA 93277
Requested Trades for Bid: All trades
Bid Date: Thursday, January 7, 2021
Bid Time: 2:00 PM
 Request that all bids be sent to Sandra Schiebelhut via Fax at (559) 798-1412 or email at bids@forcummackey.com.
Company: Forcum/Mackey Construction, Inc.
Address: 15695 Jasmine Avenue
 Ivanhoe, CA 93235
Tel: (559) 798-1837 **Fax:** (559) 798-1412

30112530

White House, VA launch REACH — a call to action to engage the nation in preventing suicide

WASHINGTON — The White House and Department of Veterans Affairs (VA) today launched the REACH national public health campaign aimed at empowering all Americans to play a critical role in preventing suicide.

The goal of REACH, which was established by the President's Roadmap to Empower Veterans and End a National Tragedy of Suicide (PREVENTS), is to change the conversation around suicide by urging people to recognize their own risk and protective factors — as well as the risk and protective factors of their loved ones.

"REACH will empower our nation's Veterans to seek and receive help and it will encourage them to reach out to their brothers and sisters in need who may be vulnerable," said VA Secretary Robert Wilkie. "The power of this campaign will change how we talk about mental health and suicide in our nation. It will ensure that those in need, especially the men and women who have served our great nation, will receive the care and support they deserve."

"The REACH campaign will inspire and educate all Americans — encouraging them to share their own struggles and to reach out to those who are hurting. It will engage our Veterans to help lead the way as we change how we think about, talk about and address suicide," said PREVENTS Executive Director Dr. Barbara Van Dahlen. "I urge everyone to go to wearewithinreach.net and take the PREVENTS Pledge to REACH and be part of the solution. Together, we will prevent suicide."

The website also includes information on factors that may protect against suicide, such as belonging to a faith-based community, healthy family relationships, having a purpose in life and strong problem-solving skills. REACH encourages everyone to intentionally strengthen their protective factors — to care for their emotional health and well-being just as they do their physical well-being.

Although suicide is preventable, the nation is facing an epidemic in deaths, with 132 Americans dying by suicide each day. In 2017 there were 47,173 suicide deaths and an estimated 1.4 million suicide attempts. For Veterans, the overall suicide rate is 1.5 times higher and the female Veteran suicide rate is 2.2 times higher than the general population after adjusting for age and/or gender.

To that end, the REACH campaign website, we are within reach, provides information to help people recognize risk factors for suicide, including financial stress, chronic illness or

Continued on page 18

INFORMATION FOR BIDDERS □

□

WARNING:

READ THIS DOCUMENT CAREFULLY. DO NOT ASSUME THAT IT IS THE SAME AS OTHER SIMILAR DOCUMENTS YOU MAY HAVE SEEN, EVEN IF FROM THE SAME DISTRICT.

1. **Overall Scope.** The Contract is for the purchase, or lease, movement and relocation and optional maintenance of DSA compliant relocatable buildings. The DISTRICT reserves the right to order any combination of items in the bid in any number as needed from the successful bidder(s). There is no implied guarantee to the bidder(s) that any items will be purchased or relocated under this bid. Award of the contract by the DISTRICT implies or guarantees no right of work to the bidder for projects involving the trades, scope, or materials included in this bid. (The DISTRICT may undertake work of a similar scope to this unit price bid under separate contracts issued via separate public bids, quotations, etc. in accordance with public contract code criteria.) The specifications for the work, compiled by Savanna School District, are incorporated into this contract in their full text. This document is to be considered directive in nature to be accomplished by the successful bidder.

- (a) **Description of the Work:** The Work consists of any and all labor, materials, goods, supplies, equipment, tools, utilities, temporary facilities, transportation, delivery services, and other services and things of any nature whatsoever as are expressly and impliedly necessary to timely and satisfactorily deliver and install portable buildings ordered by the District or by other public agencies that piggyback on the Contract as permitted by the Contract and applicable law. Without limiting the foregoing, the Work consists of any and all work and services required to provide each structure with the components and options selected by the purchaser, with all building systems complete and functioning as intended, and with each electrical, water, and, as applicable, other utility, communication and alarm system completed to one or more points of connection at the exterior of the buildings. (Exterior connections to the stubs for the utility, communication and alarm systems at the exterior of the buildings shall be by others.) The Bid Form-2, Attachment A Work line items include the delivery and installation of each portable building. In addition the Bid Form-2, Attachment B Pricing Matrix included in the Bid Documents describes the components and options that must be available to purchasers. The Bidder must specify the individual prices for ALL such buildings, components and options in the Pricing Matrix, to complete Bid Form-2 in order to be a responsive Bidder.

2. **Project Scope.** The word project shall refer to each and every separate purchase order issued during the term of the contract for the purposes of calculating bonding requirements, schedules, payments due, retention, etc. However, a project or purchase order scope will not necessarily be limited to work at a single site. The District also has prepared written requirements for materials, equipment, construction systems, quality, workmanship, services and other things to be furnished in connection with the work and the Project as listed in the Technical Specifications included in this Project Manual.

3. Project is a Public Work. Except as otherwise provided or permitted by law, the Project is a "public work" and "public project" within the meaning of various provisions of the Public Contract Code, Labor Code, Civil Code, and other applicable legal requirements. Therefore, to that extent the performance of the Work is subject to such requirements. The Contract Documents include various provisions relating to public works and public projects as provided by law, and each bidder must thoroughly review and become familiar with the Contract Documents. However, the Contract Documents do not include comprehensive statements of all requirements of law applicable to public works and public projects, and each bidder shall be deemed and construed to have acknowledged that fact by submitting a bid for the Work. In addition, by submitting a bid for the Work, each bidder shall be deemed and construed to represent and warrant that it is familiar and knowledgeable with respect to all requirements of law applicable to public works and public projects generally and to the Work specifically.

4. Contract Period. The District anticipates that its Governing Board will award a contract for this bid in November 2020. (This is subject to change at the sole discretion of the District.) The Contract Term is one (1) year after award of bid, and may be extended for additional one (1) year periods in accordance with provisions contained in the Education Code. The prices set forth on Bid Form 2 (the Schedule of Unit Costs), which the District shall pay the successful bidder, are to remain firm for the first year. Adjustments, if approved by the District, for subsequent years will not exceed the percentage change in the Consumer Price Index (CPI-U) for the Los Angeles-Anaheim-Riverside area for the year beginning January 2021 and ending November 2021, and for each subsequent one year period (on the January to January time period) if this contract is renewed. This data is available at www.bls.gov/regions/west/news-release/consumerpriceindex_losangeles.htm. The successful bidder is responsible for requesting all price increases in writing. (Price increases shall not be automatically made.) By submitting a bid, the successful bidder agrees that it is willing to provide such contract extensions under these terms if requested by the District, at District's sole discretion.

5. Contract Schedule. Work on each separate purchase order issued under this contract shall commence within one (1) calendar day of the date stated in the District's Notice to Proceed. Purchase orders may be issued anytime within the contract year to start work, but work does not necessarily have to be completed in the annual contract period.

(a) The schedule for each project initiated under this contract shall be negotiated between the District, and the successful bidder. However, a completion schedule for any one project may not exceed one-hundred eighty (180) consecutive calendar days (including installation and all punchlist items), unless Contractor is responding to a specific request for a longer schedule from the Owner. Due to DSA plan approval timelines, submittal processing and equipment ordering lead time, both parties may agree to a mobilization period prior to commencement of the contract schedule.

6. Basis of Award. The District intends to award one Contract to that responsible bidder who submits the lowest responsive bid, and whose bid, in the sole opinion of the District, best meets the Bid Specifications and requirements as outlined in the Project Documents. Bidder will be required to list prices for all bid items listed on Bid Form 2 including all attachments. Failure to fulfill this requirement may be cause for the District to reject the bid as non-responsive.

(a) The District reserves the right to reject any or all bids or to waive any irregularities or informalities in any bid or in the bidding process.

(b)□ As part of the bid submittal, the District is asking the bidder to submit a completed schedule of unit prices for various items that may or may not be included in various individual purchase orders initiated over the course of the contract. The method to determine the lowest bid will be to insert each bidder's unit prices into a sample project created by the District's Program Manager. A copy of the sample project quantity take offs will be supplied to all bidders who attend the public bid opening: after the bid submittal deadline, but before bids are opened.

(c) The District reserves the right to award a contract to the lowest bidder who can provide specified bonding, and otherwise fulfill the project requirements for each and every purchase order issued under this bid.

(d) The District will make purchases, at their discretion, from any combination of bid items. The District is not required to purchase any of the items listed, or any combination of items from any bidder.

(e) The Bids must be complete, with no "add-ons" permitted. The work under this Contract shall include all labor, materials, equipment, taxes, disposal fees, appliances, freight, and transportation necessary for complete installation. Include all City of Anaheim, Buena Park or Stanton and State of California and other applicable permits and licenses. Do not include any amount for federal excise tax in any proposal or bid, as the District is exempt from payment of federal excise taxes.

7. Preparation of Bid Form. Bids shall be submitted on the prescribed Bid Form 1 and Bid Form 2: Schedule of Unit Costs including all attachments, and shall be completed in full. All bid items and statements shall be properly and legibly filled out. The signatures of all persons shall be in longhand and in ink. Prices, wording and notations must be in ink or typewritten. Unless expressly permitted by the Bid Documents, a bidder must not: (i) make any changes, additions or other modifications to the Bid Proposal Form or other documents to be submitted with the Bid Proposal Form; (ii) restate or recharacterize the Work in the bid; or (iii) make any alternative proposals not permitted by the Bid Documents. The District may reject as non-responsive any bid that does not strictly comply with the foregoing.

8. Form and Delivery of Bids. The bid must conform and be responsive to all Project Documents and shall be made on the Bid Forms provided, and the complete bid, together with any and all additional materials as required, shall be enclosed in a sealed envelope, addressed and hand delivered or mailed to the Savanna School District main office at: 1330 S. Knott Ave, Anaheim CA 92804. All bids must be received on or before the bid deadline (Public Contract Code Section 20112.) The envelope shall be plainly marked in the upper left hand corner with the bidder's name, the Project designation and the date and time for the opening of bids. **It is the bidder's sole responsibility to ensure that its bid is received prior to the bid deadline.** In accordance with Government Code Section 53068, any bid received after the scheduled closing time for receipt of bids shall be returned to the bidder unopened. At the time and place set forth for the opening of bids, the sealed bids will be opened and publicly read aloud.

9. Bid Security. Each bid shall be accompanied by a bid security in the form of cash, a certified or cashier's check or bid bond in the amount of not less than one hundred thousand dollars, (\$100,000.00) payable to the DISTRICT and shall be given as a guarantee that the bidder, if awarded

the contract, will execute the Agreement within seven (7) working days after notice of award of the contract, and will furnish prior to the execution of any qualifying purchase order, but no later than (5) five days after notification of award, on the prescribed forms, a satisfactory Faithful Performance Bond in an amount not less than one hundred percent (100%) of the total quotation price on each and every separate purchase order issued for a project which includes materials only, or materials and installation, or labor, and which exceeds the amount of twenty-five thousand dollars (\$25,000.00) in cost, and separate Payment (labor and material) Bond in an amount not less than one hundred percent (100%) of the total quotation price on each and every separate purchase order issued for projects which include material only, or materials and installation, or labor, and which exceed the amount of twenty-five thousand dollars (\$25,000.00) in cost, all prior to execution of the purchase order for a qualifying project. In accordance with the Project documents and Civil Code Section 3248, the successful Bidder shall furnish certificates and endorsements evidencing that the required insurance is in effect, the Faithful Performance Bond, Payment Bon, Drug-Free Workplace, Workers' Compensation Certificate, Criminal Records Check Certification, Guarantee, Contractor's Certificate Regarding Non-Asbestos Containing Materials, Tobacco Free Work Place Certification, Lead-Containing Materials Notice and Certification, DVBE Certification, and Escrow Agreement, if applicable, all within five (5) working days of the notice of award of the contract or as otherwise requested in writing by the DISTRICT. It is understood and agreed that should bidder fail or refuse to return these documents as required by the DISTRICT, the bid security shall be forfeited to the DISTRICT. If the Bidder elects to furnish a bid bond as its Bid Security, the Bidder shall use the bid bond form included in the Project Documents.

(a) Note: Performance and Payment Bonds are included as an optional line item cost in the Unit Bid menu on Bid Form-2. They will only be required on projects where the District specifically chooses to include this coverage, and expressly includes the cost in any project purchase orders issued.

10. Signature. Any signature required on Project Documents must be signed in the name of the bidder and must bear the signature of the person or persons duly authorized to sign these documents. Where indicated, if bidder is a corporation, the legal name of the corporation shall first be set forth, together with two signatures: one from among the chairman of the board, president or vice president and one from among the secretary, chief financial officer, or treasurer. Alternatively, the signature of other authorized officers or agents may be affixed, if duly authorized by the corporation. Such documents shall include the title of such signatories below the signature and shall bear the corporate seal. Where indicated, in the event that the bidder is a joint venture or partnership, there shall be submitted with the bid certifications signed by authorized officers of each of the parties to the joint venture or partnership, naming the individual who shall sign all necessary documents for the joint venture or partnership and, should the joint venture or partnership be the successful bidder, who shall act in all matters relative to the Project for the joint venture or partnership. If bidder is an individual, his/her signature shall be placed on such documents.

11. Modifications. Changes in or additions to any of the bid documents, summary of the work bid upon, alternative proposals, or any other modifications which are not specifically called for by the DISTRICT may result in the DISTRICT'S rejection of the bid as being nonresponsive. No oral, telephonic, facsimile or electronic modification of any of the bid documents will be considered.

12. Erasures, Inconsistent or Illegible Bids. The bid submitted must not contain any erasures, interlineations, or other corrections unless each such correction is authenticated by affixing the initials of the person(s) signing the bid in the margin immediately adjacent to the correction. In

the event of inconsistency between words and numbers in the bid, words shall control numbers. In the event that DISTRICT determines that any bid is unintelligible, illegible or ambiguous, the DISTRICT may reject such bid as being nonresponsive.

13. Bid Protests. Any bidder that has duly submitted a bid for the Work may protest the process used to seek bids for the Work, and/or the intended award of the Contract for the Work only by filing a written protest with the District in accordance with the procedures set forth in this Section (a "Bid Protest"). The District will not accept or consider any oral Bid Protest (e.g., by telephone) or any Bid Protest sent via electronic transmission (e.g., e-mail). In order for a Bid Protest to be valid and be considered by the District, the Bid Protest:

- (a) Must be received by the District not later than 4:00 p.m. on the fifth business day following the opening of bids;
- (b) Must clearly identify the bidder that is filing the Bid Protest, together with the name, address and telephone number of the person representing the bidder for purposes of the Bid Protest;
- (c) Must clearly identify the specific bid, bidding process, or other matter that is the subject of the Bid Protest;
- (d) Must clearly identify the specific provisions of all documents relevant to the Bid Protest;
- (e) Must clearly identify and describe in detail the specific basis (or bases) for the Bid Protest and all facts relevant thereto;
- (f) Must clearly identify and describe in detail all arguments by the protesting bidder in support of the Bid Protest, including, without limitation, citations to applicable statutory requirements; and
- (g) Must be submitted with all documentation the protesting bidder desires to submit that is relevant to and supports the basis or bases underlying the Bid Protest.

If a Bid Protest does not comply with each and all of the foregoing requirements (provided that a protesting bidder will be deemed to have submitted all documentation that it desires in accordance with clause (vii) of the foregoing), the District will reject the Bid Protest as invalid. However, upon receipt of a valid Bid Protest, the District and/or its legal counsel will review the Bid Protest and provide a written response to the protesting bidder setting forth a recommendation for action by the Board of Education of the District ("Governing Board") in response to the Bid Protest. Action on a Bid Protest by the Governing Board shall be a condition precedent to the filing of any claim or demand and to the initiation of any action (legal or equitable) or other proceeding arising from the matter(s) protested.

CAUTION: Compliance with the foregoing Bid Protest requirements is mandatory. Each bidder that desires to protest must file its own Bid Protest in accordance with the foregoing requirements, and no bidder may rely on a Bid Protest by another bidder as a means of satisfying such requirements. Compliance with the foregoing requirements is the sole and exclusive means of

protesting a bid, the bidding process and/or the intended award of the Contract, and failure to so comply shall be deemed and construed as a waiver of any and all rights the bidder may have to pursue a claim, demand or action arising from any such matter.

14. Examination of Project Documents. At its own expense and prior to submitting its bid, each bidder shall examine all documents relating to the Project, and determine the local conditions which may in any way affect the performance of the work, including the general prevailing rates of per diem wages and other relevant cost factors; familiarize itself with all Federal, State and Local laws, ordinances, rules, regulations and codes affecting the performance of the work, including the cost of permits and licenses required for the work; make such surveys and investigations, as it may deem necessary for performance of the work at its bid price ; determine the character, quality, and quantities of the work to be performed and the materials and equipment to be provided; and correlate its observations, investigations, and determinations with all requirements of the Project . **Bidder agrees that the submission of a bid shall be incontrovertible evidence that the bidder has complied with all the requirements of this provision of the Information for Bidders.**

15. Withdrawal of Bids. Any bid may be withdrawn, either personally or by written request signed by the bidder, at any time prior to the scheduled closing time for receipt of bids. The bid security for a bid withdrawn prior to the scheduled closing time for receipt of bids, in accordance with this paragraph, shall be returned. No bidder may withdraw any bid for a period of ninety (90) calendar days after the date set for the opening of bids.

16. Agreement and Bonds. The Agreement which the successful bidder will be required to execute and the payment bond required in accordance with Civil Code Section 3247, are included in the Project Documents. The payment bond shall be in the amount not less than one hundred percent (100%) of the amount of the quotation price on each and every separate purchase order issued for projects which include materials only, or materials and installation or labor, and which exceeds the amount of twenty-five thousand (\$25,000.00) in cost, in accordance with Civil Code Section 3248. The successful bidder will also be required to furnish a separate faithful performance bond in the amount of one hundred percent (100%) of the price quotation on each and every separate purchase order for a project which includes materials and any installation, or labor, and which exceeds the amount of twenty-five thousand dollars (\$25,000.00) in cost, in the form included in the Project Documents all prior to execution of the purchase order for a particular project, which shall remain in full force and effect through the guarantee period as specified in the General Conditions. All bond premiums shall be at bidder's cost, as listed on Bid Form 2.

(a) Note: Performance and Payment Bonds are included as an optional line item cost in the Unit Bid menu on Bid Form-2. They will only be required on projects where the District specifically chooses to include this coverage, and expressly includes the cost in any project purchase orders issued.

17. Interpretation of Project Documents. If any bidder is in doubt as to the true meaning of any part of the Project Documents, or finds discrepancies in, or omissions from the Project Documents, a written request for an interpretation or correction submitted on the form provided in this manual, thereof must be submitted to the Program Manager, four (4) calendar days before the bid deadline (tentatively to be Noon on Monday, December 7, 2020.) Requests for Information (RFIs) shall be submitted via email to Cindy Leighton, Program Manager at cindy@schoolhausinc.com. No requests shall be considered after this time. The bidder submitting

the written request shall be responsible for its prompt delivery. Any interpretation or correction of the Project Documents will be made solely at DISTRICT's discretion and only by written addendum duly issued by the DISTRICT, and a copy of such addendum will be emailed to each bidder attending the Mandatory Pre-Construction Conference, or known to have purchased a set of the Project Documents. No person is authorized to make any oral interpretation of any provision in the Project Documents, nor shall any oral interpretation of Project Documents be binding on the DISTRICT. If there are discrepancies of any kind in the Project Documents, the interpretation of the DISTRICT shall prevail. **SUBMITTAL OF A BID WITHOUT A REQUEST FOR CLARIFICATIONS SHALL BE INCONTROVERTIBLE EVIDENCE THAT THE BIDDER HAS DETERMINED THAT THE PROJECT DOCUMENTS ARE ACCEPTABLE AND SUFFICIENT FOR BIDDING AND COMPLETING THE WORK; THAT BIDDER IS CAPABLE OF READING, FOLLOWING AND COMPLETING THE WORK IN ACCORDANCE WITH THE PROJECT DOCUMENTS; AND THAT BIDDER AGREES THAT THE PROJECT CAN AND WILL BE COMPLETED ACCORDING TO THE DISTRICT'S TIMELINES AND ACCORDING TO THE PROGRESS SCHEDULE TO BE SUBMITTED BY THE SUCCESSFUL BIDDER INCORPORATING THE DISTRICT'S TIMELINES FOR COMPLETION OF THE PROJECT.**

18. Bidders Interested in More Than One Bid. No person, firm or corporation shall be allowed to make, or file, or be interested in more than one bid for the same work unless alternate bids are specifically called for by the DISTRICT. A person, firm, or corporation that has submitted a subproposal to a bidder, or that has quoted prices of materials to a bidder, is not thereby disqualified from submitting a proposal or quoting prices to other bidders or submitting a bid on the Project.

19. Award of Contract. The DISTRICT reserves the right to reject any or all bids, or to waive any irregularities or informalities in any bids or in the bidding process. The award of the contract, if made by the DISTRICT, will be by action of the Governing Board and to the lowest responsive and responsible bidder. If two identical low bids are received from responsive and responsible bidders, the DISTRICT will determine which bid will be accepted pursuant to Public Contract Code Section 20117. In the event an award of the contract is made to a bidder, and such bidder fails or refuses to execute the Agreement within five (5) days and provide the required documents within five (5) working days after the notice of award of the contract to bidder, the DISTRICT may award the contract to the next lowest responsive and responsible bidder or reject all bidders.

20. Competency of Bidders. In selecting the lowest responsive and responsible bidder, consideration will be given not only to the financial standing but also to the general competency of the bidder for the performance of the Project. By submitting a bid, each bidder agrees that the DISTRICT, in determining the successful bidder and its eligibility for the award, may consider the bidder's experience and facilities, conduct and performance under other contracts, financial condition, reputation in the industry, and other factors which could affect the bidder's performance of the Project. To this end, each bid shall be supported by a statement of the bidder's experience on the form entitled "INFORMATION REQUIRED OF BIDDER."

The DISTRICT may also consider the qualifications and experience of subcontractors and other persons and organizations (including those who are to furnish the principal items of material and equipment) proposed for those portions of the work. Operating costs, maintenance considerations, performance data and guarantees of materials and equipment may also be considered

by the DISTRICT. In this regard, the DISTRICT may conduct such investigations as the DISTRICT deems necessary to assist in the evaluation of any bid and to establish the responsibility, qualifications and financial ability of the bidder, proposed subcontractors, and other persons and organizations to do the work to the DISTRICT's satisfaction within the prescribed time. The DISTRICT reserves the right to reject the bid of any bidder who does not pass any such evaluation to the satisfaction of the DISTRICT.

21. Listing Subcontractors. Each bidder shall submit, on the form furnished with the Project Documents, a list of the proposed subcontractors on this Project as required by the Subletting and Subcontracting Fair Practices Act (Public Contract Code Section 4100, et seq.). If the bidder fails to specify a subcontractor for any portion of the work in excess of one half (1/2) of one percent (1%) of the bidder's total bid, the bidder agrees that he/she is fully qualified to perform that work and agrees to perform that portion of the work. Violation of this requirement (including the procurement of a subcontractor for the Project if no subcontractor is specified) can result in the DISTRICT invoking the remedies of Public Contract Code Sections 4110 and 4111.

(a) Since this is a unit bid format, Bidders must list sub-contractors for all items included in the scope of all contract line items included on Bid Form-2. This includes listing third tier sub-contractors.

22. Insurance and Workers' Compensation. The successful bidder shall be required to furnish certificates and endorsements evidencing that the required insurance is in effect. DISTRICT may request that such certificates and endorsements are completed on DISTRICT provided forms. In accordance with the provisions of Section 3700 of the Labor Code, the successful bidder shall secure the payment of compensation to all employees. The successful bidder who has been awarded the contract shall sign and file with DISTRICT prior to performing the work, the Workers' Compensation Certificate included as a part of the Project Documents. Labor Code Section 1861.

23. Contractor's License. If, at the time and date of the bid opening, bidder is not properly licensed to perform the Project in accordance with Division 3, Chapter 9, of the Business and Professions Code and the Project Documents, such bid will be rejected as nonresponsive. (Public Contract Code Section 3300) Pursuant to Business and Professions Code Section 7028.15, no payment shall be made for work or materials under the contract unless and until the Registrar of Contractors verifies to the DISTRICT that the bidder was properly licensed at the time the bid was submitted. Any bidder not so licensed is subject to penalties under the law and the contract will be considered void and DISTRICT shall have the right to bring an action against the unlicensed bidder awarded the contract for recovery of all compensation paid under the contract. (Business and Professions Code Section 7031(b)) If the license classification specified hereinafter is that of a "specialty contractor" as defined in Section 7058 of the Business and Professions Code, the specialty contractor awarded the contract for this work shall construct a majority of the work, in accordance with the provisions of Business and Professions Code Section 7059. The bidder may not use the contractor license of a third party for this bid.

(a) Department of Industrial Relations (DIR) Registration: The bidder and all listed subcontractors must be registered with the DIR in accordance with SB 854, and pursuant to Labor Code Section 1725.5. This project is subject to prevailing wage compliance monitoring and enforcement by the DIR.

(b) Subcontractor Eligibility and Licensing: The Successful Bidder shall in no event permit a subcontractor to perform any of the Work if that subcontractor is ineligible

to work on a public works or public project. Each subcontractor that the Successful Bidder intends shall perform any portion of the Work must be licensed in accordance with law by the Contractors State License Board prior to commencing its portion of the Work.

24. Anti-Discrimination. In connection with all work performed under this Project, there shall be no unlawful discrimination by the successful bidder or any of its sub-contractors or suppliers, against any prospective or active employee engaged in the work because of race, color, ancestry, national origin, religious creed, sex, age, marital status, physical disability, mental disability, or medical condition. The successful bidder agrees to comply with applicable Federal and State laws including, but not limited to, the California Fair Employment and Housing Act, beginning with Government Code Section 12900 and Labor Code Section 1735. In addition, the successful bidder agrees to require like compliance by any subcontractors employed on the Project by such bidder.

25. Hold Harmless and Indemnification. The successful bidder awarded the contract will be required to indemnify and hold harmless the DISTRICT, its Governing Board, officers, agents, and employees as set forth in the Agreement.

26. Preference for Materials and Substitutions. Unless the Plans and Specifications state that no Substitution is permitted, whenever the Contract Documents indicate any specific article, device, equipment, product, material, fixture, patented process, form, method, construction, or any specific name, make, trade name, or catalog number, with or without the words, “or equal,” such specification shall be read as if the language “or equal” is incorporated.

(a) Request for Substitution. Bidder may, unless otherwise stated, offer any material, process, article, etc., which is materially equal or better in every respect to that so indicated or specified (“Specified Item”) and will completely accomplish the purpose of the Contract Document. If bidder desires to offer a Substitution for a Specified Item, such Bidder must make a request in writing on the District’s Substitution Request Form (“Request Form”) included in these documents and submit the completed Request Form with the Bidder’s bid.

The Request Form must be accompanied by evidence as to whether the proposed substitution:

- 1) Is equal in quality, service, and ability to the Specified Item as demonstrated by a side by side comparison of key characteristics and performance criteria (CSI comparison chart);
- 2) Will entail no changes in detail, construction and scheduling of related work;
- 3) Will be acceptable in consideration of the required design and artistic effect;
- 4) Will provide no cost disadvantage to the District;
- 5) Will require no excessive or more expensive maintenance, including adequacy and availability of replacement parts; and
- 6) Will require no change in the Contract Time.

In completing the Request Form, Bidder must state with respect to each requested substitution whether bidder will agree to provide the Specified Item in the event that the District denies Bidder's request for substitution of a Specified Item. In the event that Bidder does not agree in the Request Form to provide the Specified Item and the District denies the requested Substitution, the Bidder's bid shall be considered non-responsive and the District may award the Contract to the next lowest Bidder or in its sole discretion, release all bidders. In the event that Bidder has agreed in the Request Form to provide the Specified Item and the District denies Bidder's requested substitution for a Specified Item, Bidder shall execute the Agreement and provide the Specified Item without any additional cost or charge to the District, and if Bidder fails to execute the Agreement with the Specified Item(s), Bidder's bid bond will be forfeited.

After the bids are opened, all Bidders shall provide, within one (1) calendar day of opening such bids, any and all Drawings, Specifications, samples, performance data, calculations, and other information as may be required to assist the Architect and the District in determining whether the proposed substitution is acceptable. The burden of establishing these facts shall be upon the Bidder.

After the District's receipt of such evidence by Bidder, the District will make its final decision as to whether the bidder's request for Substitution for any Specified Items will be granted. The District shall have sole discretion in deciding as to whether a proposed request for Substitution is equal to or better than a Specified Item. Any request for Substitution which is granted by the District shall be documented and processed through a Change Order. The District may condition its approval of any Substitution upon delivery to the District of an extended warranty or other assurances of adequate performance of the Substitution. Any and all risks of delay due to DSA, or any other governmental agency having jurisdiction shall be on the Bidder.

27. Surety Qualifications for Bonds. Bidders shall ensure all surety companies have a minimum rating of "A-VIII," as rated by the current edition of Best's Key Rating Guide, published by A.M. Best Company, Oldwick, New Jersey 08858. Only California admitted surety insurers will be acceptable for the issuance of bonds. (Code of Civil Procedure Section 995.311) DISTRICT shall verify the status of the surety by one of the following ways: (1) printing out information from the website of the California Department of Insurance confirming the surety is an admitted surety insurer and attaching it to the bond, or (2) obtaining a certificate from the county clerk for the county in which the DISTRICT is located that confirms the surety is an admitted surety insurer and attaching it to the bond. Any admitted surety insurer who cannot satisfy the minimum rating specified above, but who satisfies the following requirements set forth in Code of Civil Procedure Section 995.660 shall be accepted and approved for the issuance of bonds:

(a) There must be on file in the office of the county clerk, for the county in which the DISTRICT is located, an unrevoked appointment, power of attorney, bylaws, or other instrument, duly certified by the proper authority and attested by the seal of the insurer authorizing the person who executed the bond to do so for and on behalf of the insurer within ten (10) calendar days of the insurer's receipt of a request to submit such document from the DISTRICT, and an original or certified copy of the document must be submitted to the DISTRICT.

(b) A certified copy of the certificate of authority of the insurer issued by the Insurance Commissioner must be submitted to the DISTRICT within ten (10) calendar days of the insurer's receipt of a request to submit such document from the DISTRICT.

(c) A certificate from the clerk of the county that the certificate of authority of the insurer has not been surrendered, revoked, cancelled, annulled, or suspended, and in the event it has, whether renewed authority has been granted must be submitted to DISTRICT within ten (10) calendar days of the insurer's receipt of a request to submit such document from the DISTRICT.

(d) Copies of the insurer's most recent annual statement and quarterly statement filed with the California Department of Insurance must be submitted to the DISTRICT within ten (10) calendar days of the insurer's receipt of a request to submit the statements.

28. Liquidated Damages. All work must be completed within the time limits set forth in the Project Documents and described further under Item 5, Contract Schedule, of the Information for Bidders. It is agreed that damages for the failure to complete the Project described herein within the time limits required are impossible to ascertain. Should the work not be completed within the specified time for completion, the successful bidder awarded the contract shall be liable for liquidated damages, payable to the DISTRICT, in an amount of five-hundred Dollars (\$500.00) for each consecutive calendar day of delay in completion. Such damages shall be deducted from any payments due or to become due to the successful bidder. Government Code Section 53069.85, Civil Code Section 1671.

29. Drug-Free Workplace Certification. Pursuant to Government Code Sections 8350, et seq., the successful bidder will be required to execute a Drug-Free Workplace Certification upon execution of the Agreement. The bidder will be required to take positive measures outlined in the certification in order to ensure the presence of a drug-free workplace. Failure to abide with the conditions set forth in the Drug-Free Workplace Act could result in penalties including termination of the Agreement or suspension of payment thereunder.

30. Noncollusion Affidavit. In accordance with the provisions of Section 7106 of the Public Contract Code, each bid must be accompanied by a noncollusion affidavit properly notarized.

31. Escrow Agreement. Public Contract Code Section 22300 permits the substitution of securities for any monies withheld by a public agency to ensure performance under a contract. At the request and expense of the successful bidder awarded the contract, securities equivalent to the amount withheld as retention shall be deposited with the DISTRICT, or with a state or federally chartered bank in California as the escrow agent, who shall then pay such monies to the successful bidder. The DISTRICT retains the sole discretion to approve the bank selected by the successful bidder to serve as escrow agent. Upon satisfactory completion of the contract, the securities shall be returned to the successful bidder. Securities eligible for investment shall include those listed in Government Code Section 16430 or bank or savings and loan certificates of deposit. The successful bidder shall be the beneficial owner of any securities substituted for monies withheld and shall receive any interest thereon.

In the alternative, under Section 22300, the successful bidder may request DISTRICT to make payment of earned retentions directly to the escrow agent at the expense of the successful bidder. Also at the successful bidder's expense, the successful bidder may direct investment of the payments into securities, and the successful bidder shall receive interest earned on such investment upon the same conditions as provided for securities deposited by successful bidder. Upon satisfactory completion of the contract, successful bidder shall receive from the escrow agent all

securities, interest and payments received by escrow agent from DISTRICT pursuant to the terms of Section 22300.

The successful bidder who elects to receive interest on monies withheld in retention by the DISTRICT shall, at the request of any subcontractor performing more than five percent (5%) of the successful bidder's total bid, make that option available to the subcontractor regarding any monies withheld in retention by the successful bidder from the subcontractor. If the successful bidder elects to receive interest on any monies withheld in retention by the DISTRICT, then the subcontractor shall receive the identical rate of interest received by the successful bidder on any retention monies withheld from the subcontractor by the successful bidder, less any actual pro rata costs associated with administering and calculating that interest. In the event that the interest rate is a fluctuating rate, the rate for the subcontractor shall be determined by calculating the interest rate paid during the time that retentions were withheld from the subcontractor. If the successful bidder elects to substitute securities in lieu of retention, then, by mutual consent of the successful bidder and subcontractor, the subcontractor may substitute securities in exchange for the release of monies held in retention by the successful bidder. Public Contract Code Section 22300(d)(1).

The successful bidder wishing to utilize Public Contract Code Section 22300 and enter into an Escrow Agreement shall complete and execute the form Escrow Agreement included in the Project Documents and submit it to the DISTRICT.

32. Change Orders. All change order requests must be submitted in the forms set forth in the Project Documents and pursuant to Article 57 of the General Conditions. The amount of allowable charges submitted pursuant to a change order shall be limited to the charges allowed under Article 57 of the General Conditions. Indirect, consequential and incidental costs, project management costs, extended home office and field office overhead, administrative costs and profit and other charges not specifically authorized under Article 57 of the General Conditions will not be allowed.

33. Tobacco-Free Policy. The successful Bidder shall submit the certification form included in these documents. The successful bidder shall agree to enforce a tobacco-free work site. No smoking will be permitted on school property including in parking lots, even inside worker vehicles.

34. Criminal Records Check. The successful bidder will be required to comply with the applicable requirements of Education Code Section 45125.1 with respect to fingerprinting of employees and must complete the District's Criminal Records Check Certification.

35. Lead. The successful Bidder shall submit the certification form included in these documents. Pursuant to the Lead-Safe Schools Protection Act (Education Code Sections 32240, et seq.) and other applicable law, the successful bidder shall not use lead-based paint, lead plumbing and solders, or other potential sources of lead contamination in the construction of any new school facility or the modernization or renovation of any existing school facility.

36. Documents Required. The number of executed copies of the Agreement, the Faithful Performance Bond, and the Payment Bond required (when Bonds are included in the project scope and cost,) is four (4).

37. Temporary Facilities. The inspector's field office shall be not less than zero (0) square feet of floor area.

38. Payment/Retention. Payment may be made in proportion to the completion of the work on each and every individual purchase order issued under this Contract, on a schedule mutually agreed upon between the District and Contractor. The District will retain five percent (5%) of monies due on each and every purchase order issued under this contract, in excess of \$15,000.00. The District will file a Notice of Completion on projects in excess of \$15,000.00. The five percent (5%) retention on these projects will be processed only after thirty-five (35) days from the filing of the Notice of Completion, and acceptance of the project by the District.

39. Hazardous Chemical/MSDS Sheets. The Contractor shall have available, and shall furnish to the District upon request, Material Safety Data Sheets for all chemical products used in the performance of this Contract. All products used shall be free of known carcinogens and shall comply in all respects with the current Safety Code of the California Division of Industrial Safety, and all OSHA requirements. The Contractor's Certificate Regarding Non-Asbestos Containing Materials shall be completed and submitted by the successful bidder.

40. Bidder Investments in Iran. Subject to certain exceptions, the Iran Contracting Act of 2010 (Public Contract Code Section 2200 et seq.) prohibits a party that engages in investment activities in Iran, as described in Public Contract Code Section 2202.5, from entering into any contract of \$1,000,000 or more for goods or services to be provided to a public entity. Each bidder must complete, execute and deliver to the District, with its bid, the "Iran Contracting Act Certification" form, which is included as one of the Required Bid Forms.

41. Piggybacking by Other Public Agencies. By submitting a bid for the Project, the Successful Bidder shall be deemed and construed to have acknowledged and agreed that, to the extent permitted by Public Contract Code Sections 20118 and 20652, and during the period in which the Contract is in effect (including, without limitation, any extensions thereto), the Successful Bidder shall allow other California public school districts and community college districts to lease and/or purchase the personal property and associated incidental services specified in the Contract ("Personal Property") on the same terms and conditions as set forth in the Contract. To the extent permitted by applicable laws, the Successful Bidder may allow public agencies to lease and/or purchase the personal property and/or services specified in the Contract on the same or better terms and conditions as set forth in the Contract. To accommodate such "piggybacking" on the Contract by other public agencies and notwithstanding anything else in the Contract Documents: (i) the initial term of the Contract shall commence on the date the District awards the Contract to the Successful Bidder and shall expire on the second anniversary of such date (i.e. a two-year initial term); and (ii) the prices for the personal property and associated incidental services specified in the Contract shall remain in effect at all times during the term of the Contract. The District and the Successful Bidder may agree in writing to extend the term of the Contract.

- (a) Contracts with Other Agencies/Rights to Order: Other public school DISTRICTS, community college DISTRICTs, and public agencies throughout the State of California including, but not necessarily limited to the attached list (Attachment #1), may lease or purchase identical items at the same unit price(s) subject to the same terms and conditions, pursuant to Sections 20118 and 20652 of the Public Contract Code. Savanna School District waives its right to require other DISTRICTs to draw their warrants in favor of the DISTRICT and authorizes each DISTRICT/agency to make payments directly to the successful bidder

42. DVBE Participation Requirements. In accordance with Education Code Section 17076.11, the Savanna School District has a participation goal for Disabled Veteran Business Enterprises of at least three percent (3%) per year of the overall dollar amount of funds allocated by the District by the State Allocation Board pursuant to the Leroy F. Greene School Facilities Act of 1998 for construction or modernization of school buildings and expended each year by the District. At the time of execution of the contract, the Contractor will provide a statement to the District of anticipated participation of Disabled Veteran Business Enterprises in the contract. Note that this form may be used for this initial statement by filling out the statement below. Prior to, and as a condition precedent for final payment under the contract, the Contractor will provide appropriate documentation to the District identifying the amount paid to Disabled Veteran Business Enterprises pursuant to the contract, so that the District can assess its success at meeting this goal.

Information for Bidders, Attachment #1

The following list includes but does not limit the entities which are able to participate in this contract as per conditions set forth in the State of California Contract Code:

California School Districts (alphabetical)

ABC Unified School District
Acalanes Union High School District
Ackerman Charter School District
Acton-Agua Dulce Unified School District
Adelanto Elementary School District
Alameda Unified School District
Alameda County Office of Education
Albany City Unified School District
Alexander Valley Union Elementary School District
Alhambra Unified School District
Alisal Union School District
Allensworth Elementary School District
Alpaugh Unified School District
Alpine County Office of Education
Alpine County Unified School District
Alpine Union Elementary School District
Alta Loma Elementary School District
Alta Vista Elementary School District
Alta-Dutch Flat Union School District
Alum Rock Union Elementary School District
Alview-Dairyland Union Elementary School District
Alvina Elementary School District
Alvord Unified School District
Amador County Office of Education
Amador County Unified School District
American Union Elementary School District
Anaheim Elementary School District
Anaheim Union High School District
Anderson Union High School District
Anderson Valley Unified School District
Antelope Elementary School District
Antelope Valley Union High School District
Antioch Unified School District
Apple Valley Unified School District
Arcadia Unified School District
Arcata Elementary School District
Arcohe Union Elementary School District
Arena Union Elementary School District
Armona Union Elementary School District
Aromas-San Juan Unified School District
Arvin Union School District
Atascadero Unified School District
Atwater Elementary School District
Auburn Union Elementary School District
Azusa Unified School District
Baker Valley Unified School District
Bakersfield City School District
Baldwin Park Unified School District
Ballard Elementary School District
Ballico-Cressey Elementary School District
Bangor Union Elementary School District
Banning Unified School District
Banta Elementary School District
Barstow Unified School District
Bass Lake Joint Union Elementary School District
Bassett Unified School District
Bayshore Elementary School District
Bear Valley Unified School District

Beardsley Elementary School District
Beaumont Unified School District
Bella Vista Elementary School District
Bellevue Elementary School District
Bellevue Union School District
Bellflower Unified School District
Belmont-Redwood Shores Elementary School District
Belridge Elementary School District
Benicia Unified School District
Bennett Valley Union Elementary School District
Berkeley Unified School District
Berryessa Union Elementary School District
Beverly Hills Unified School District
Big Creek Elementary School District
Big Lagoon Union Elementary School District
Big Oak Flat-Groveland Unified School District
Big Pine Unified School District
Big Springs Union Elementary School District
Big Valley Joint Unified School District
Biggs Unified School District
Bishop Unified School District
Bitterwater-Tully Elementary School District
Black Butte Union Elementary School District
Black Oak Mine Unified School District
Blake Elementary School District
Blochman Union Elementary School District
Blue Lake Union Elementary School District
Bogus Elementary School District
Bolin-Sunson Union School District
Bonita Unified School District
Bonny Doon Union Elementary School District
Bonsall Unified School District
Borrego Springs Unified School District
Bradley Union Elementary School District
Brawley Elementary School District
Brawley Union High School District
Brea Olinda Unified School District
Brentwood Union Elementary School District
Bret Harte Union High School District
Bridgeville Elementary School District
Briggs Elementary School District
Brisbane Elementary School District
Brittan Elementary School District
Browns Elementary School District
Buckeye Union Elementary School District
Buellton Union Elementary School District
Buena Park Elementary School District
Buena Vista Elementary School District
Burbank Unified School District
Burlingame Elementary School District
Burnt Ranch Elementary School District
Burrel Union Elementary School District
Burton Elementary School District
Butte County Office of Education
Butte Valley Unified School District
Butteville Union Elementary School District
Buttonwillow Union Elementary School District
Byron Union Elementary School District
Cabrillo Unified School District
Cajon Valley Union School District
Calaveras County Office of Education
Calaveras Unified School District
Calexico Unified School District
Caliente Union Elementary School District
Calipatria Unified School District
Calistoga Joint Unified School District
Cambrian School District

Information for Bidders, Attachment #1

Camino Union Elementary School District
Campbell Union School District
Campbell Union High School District
Camptonville Elementary School District
Canyon Elementary School District
Capay Joint Union Elementary School District
Capistrano Unified School District
Cardiff Elementary School District
Carlsbad Unified School District
Carpinteria Unified School District
Caruthers Unified School District
Cascade Union Elementary School District
Casmalia Elementary School District
Castaic Union School District
Castle Rock Union Elementary School District
Castro Valley Unified School District
Cayucos Elementary School District
Center Joint Unified School District
Centinela Valley Union High School District
Central Unified School District
Central Union Elementary School District
Central Union High School District
Centralia Elementary School District
Ceres Unified School District
Chaffey Joint Union High School District
Charter Oak Unified School District
Chatom Union School District
Chawanakee Unified School District
Chicago Park Elementary School District
Chico Unified School District
Chino Valley Unified School District
Chowchilla Elementary School District
Chowchilla Union High School District
Chualar Union School District
Chula Vista Elementary School District
Cienega Union Elementary School District
Cinnabar Elementary School District
Claremont Unified School District
Clay Joint Elementary School District
Clear Creek Elementary School District
Cloverdale Unified School District
Clovis Unified School District
Coachella Valley Unified School District
Coalinga-Huron Unified School District
Coast Unified School District
Coffee Creek Elementary School District
Cold Spring Elementary School District
Colfax Elementary School District
College Elementary School District
Colton Joint Unified School District
Columbia Elementary School District
Columbia Union School District
Columbine Elementary School District
Colusa County Office of Education
Colusa Unified School District
Compton Unified School District
Conejo Valley Unified School District
Contra Costa County Office of Education
Corcoran Joint Unified School District
Corning Union Elementary School District
Corning Union High School District
Corona-Norco Unified School District
Coronado Unified School District
Cotati-Rohnert Park Unified School District
Cottonwood Union School District
Covina-Valley Unified School District
Cucamonga Elementary School District
Cuddeback Union Elementary School District
Culver City Unified School District
Cupertino Union School District
Curtis Creek School District
Cutler-Orosi Joint Unified School District
Cутten Elementary School District
Cuyama Joint Unified School District
Cypress Elementary School District
Davis Joint Unified School District
Death Valley Unified School District
Dehesa Elementary School District
Del Mar Union Elementary School District
Del Norte County Office of Education
Del Norte County Unified School District
Delano Joint Union High School District
Delano Union Elementary School District
Delhi Unified School District
Delphic Elementary School District
Denair Unified School District
Desert Center Unified School District
Desert Sands Unified School District
Di Giorgio Elementary School District
Dinuba Unified School District
Dixon Unified School District
Dos Palos-Oro Loma Joint Unified School District
Douglas City Elementary School District
Downey Unified School District
Dry Creek Joint Elementary School District
Duarte Unified School District
Dublin Unified School District
Ducor Union Elementary School District
Dunham Elementary School District
Dunsmuir Elementary School District
Dunsmuir Joint Union High School District
Durham Unified School District
Earlimart Elementary School District
East Nicolaus Joint Union High School District
East Side Union High School District
East Whittier City Elementary School District
Eastern Sierra Unified School District
Eastside Union Elementary School District
Edison Elementary School District
El Centro Elementary School District
El Dorado County Office of Education
El Dorado Union High School District
El Monte City School District
El Monte Union High School District
El Nido Elementary School District
El Rancho Unified School District
El Segundo Unified School District
El Tejon Unified School District
Elk Grove Unified School District
Elk Hills Elementary School District
Elkins Elementary School District
Elverta Joint Elementary School District
Emery Unified School District
Empire Union Elementary School District
Encinitas Union Elementary School District
Enterprise Elementary School District
Escalon Unified School District
Escondido Union School District
Escondido Union High School District
Esparto Unified School District
Etiwanda Elementary School District
Eureka City Schools District
Eureka Union School District
Evergreen Elementary School District

Information for Bidders, Attachment #1

Evergreen Union School District
Exeter Unified School District
Fairfax Elementary School District
Fairfield-Suisun Unified School District
Fall River Joint Unified School District
Fallbrook Union Elementary School District
Fallbrook Union High School District
Farmersville Unified School District
Ferndale Unified School District
Fieldbrook Elementary School District
Fillmore Unified School District
Firebaugh-Las Deltas Unified School District
Flournoy Union Elementary School District
Folsom-Cordova Unified School District
Fontana Unified School District
Foresthill Union Elementary School District
Forestville Union Elementary School District
Forks of Salmon Elementary School District
Fort Bragg Unified School District
Fort Ross Elementary School District
Fort Sage Unified School District
Fortuna Elementary School District
Fortuna Union High School District
Fountain Valley Elementary School District
Fowler Unified School District
Franklin Elementary School District
Franklin-McKinley Elementary School District
Fremont Unified School District
Fremont Union High School District
French Gulch-Whiskeytown Elementary School District
Freshwater Elementary School District
Fresno County Office of Education
Fresno Unified School District
Fruitvale Elementary School District
Fullerton Elementary School District
Fullerton Joint Union High School District
Galt Joint Union Elementary School District
Galt Joint Union High School District
Garden Grove Unified School District
Garfield Elementary School District
Garvey Elementary School District
Gateway Unified School District
Gazelle Union Elementary School District
General Shafter Elementary School District
Gerber Union Elementary School District
Geyserville Unified School District
Gilroy Unified School District
Glendale Unified School District
Glendora Unified School District
Glenn County Office of Education
Gold Oak Union Elementary School District
Gold Trail Union Elementary School District
Golden Feather Union Elementary School District
Golden Plains Unified School District
Golden Valley Unified School District
Goleta Union Elementary School District
Gonzales Unified School District
Gorman Joint School District
Grant Elementary School District
Grant Joint Union High School District
Grass Valley Elementary School District
Gratton Elementary School District
Gravenstein Union Elementary School District
Graves Elementary School District
Green Point Elementary School District
Greenfield Union School District
Greenfield Union Elementary School District
Grenada Elementary School District
Gridley Unified School District
Grossmont Union High School District
Guadalupe Union Elementary School District
Guerneville Elementary School District
Gustine Unified School District
Hacienda La Puente Unified School District
Hamilton Unified School District
Hanford Elementary School District
Hanford Joint Union High School District
Happy Camp Union Elementary School District
Happy Valley Elementary School District
Happy Valley Union Elementary School District
Harmony Union Elementary School District
Hart-Ransom Union Elementary School District
Hawthorne School District
Hayward Unified School District
Healdsburg Unified School District
Heber Elementary School District
Helendale Elementary School District
Hemet Unified School District
Hermosa Beach City Elementary School District
Hesperia Unified School District
Hickman Community Charter School District
Hillsborough City Elementary School District
Hilmar Unified School District
Hollister School District
Holtville Unified School District
Hope Elementary School District
Horicon Elementary School District
Hornbrook Elementary School District
Hot Springs Elementary School District
Howell Mountain Elementary School District
Hueneme Elementary School District
Hughes-Elizabeth Lakes Union Elementary School District
Hughson Unified School District
Humboldt County Office of Education
Huntington Beach City Elementary School District
Huntington Beach Union High School District
Hydesville Elementary School District
Igo, Ono, Platina Union Elementary School District
Imperial County Office of Education
Imperial Unified School District
Indian Diggings Elementary School District
Indian Springs Elementary School District
Inglewood Unified School District
Inyo County Office of Education
Irvine Unified School District
Island Union Elementary School District
Jacoby Creek Elementary School District
Jamestown Elementary School District
Jamul-Dulzura Union Elementary School District
Janesville Union Elementary School District
Jefferson Elementary School District
Jefferson Union High School District
John Swett Unified School District
Johnstonville Elementary School District
Julian Union Elementary School District
Julian Union High School District
Junction City Elementary School District
Junction Elementary School District
Jurupa Unified School District
Kashia Elementary School District
Kelseyville Unified School District
Kentfield Elementary School District
Kenwood School District
Keppel Union Elementary School District

Information for Bidders, Attachment #1

Kerman Unified School District
Kern County Office of Education
Kern High School District
Kernville Union Elementary School District
Keyes Union School District
King City Union School District
Kings Canyon Joint Unified School District
Kings County Office of Education
Kings River Union Elementary School District
Kings River-Hardwick Union Elementary School District
Kingsburg Elementary Charter School District
Kingsburg Joint Union High School District
Kirkwood Elementary School District
Kit Carson Union Elementary School District
Klamath River Union Elementary School District
Klamath-Trinity Joint Unified School District
Kneeland Elementary School District
Knights Ferry Elementary School District
Knightsen Elementary School District
Konociti Unified School District
La Canada Unified School District
La Habra City Elementary School District
La Honda-Pescadero Unified School District
La Mesa-Spring Valley School District
Lafayette Elementary School District
Laguna Beach Unified School District
Laguna Joint Elementary School District
Lagunita Elementary School District
Lagunitas Elementary School District
Lake County Office of Education
Lake Elementary School District
Lake Elsinore Unified School District
Lake Tahoe Unified School District
Lakeport Unified School District
Lakeside Joint School District
Lakeside Union Elementary School District
Lakeside Union School District
Lammersville Joint Unified School District
Lamont Elementary School District
Lancaster Elementary School District
Larkspur Elementary School District
Las Lomas Elementary School District
Las Virgenes Unified School District
Lassen County Office of Education
Lassen Union High School District
Lassen View Union Elementary School District
Laton Joint Unified School District
Latrobe School District
Lawndale Elementary School District
Laytonville Unified School District
Le Grand Union Elementary School District
Le Grand Union High School District
Leggett Valley Unified School District
Lemon Grove School District
Lemoore Union Elementary School District
Lemoore Union High School District
Lennox School District
Lewiston Elementary School District
Liberty Elementary School District
Liberty Union High School District
Lincoln Elementary School District
Lincoln Unified School District
Linden Unified School District
Lindsay Unified School District
Linns Valley-Poso Flat Union School District
Little Lake City Elementary School District
Little Shasta Elementary School District
Live Oak Elementary School District
Live Oak Unified School District
Livermore Valley Joint Unified School District
Livingston Union School District
Lodi Unified School District
Loleta Union Elementary School District
Loma Prieta Joint Union Elementary School District
Lompoc Unified School District
Lone Pine Unified School District
Long Beach Unified School District
Loomis Union Elementary School District
Los Alamos Elementary School District
Los Altos Elementary School District
Los Angeles County Office of Education
Los Angeles Unified School District
Los Banos Unified School District
Los Gatos Union Elementary School District
Los Gatos-Saratoga Union High School District
Los Molinos Unified School District
Los Nietos School District
Los Olivos Elementary School District
Lost Hills Union Elementary School District
Lowell Joint School District
Lucerne Elementary School District
Lucerne Valley Unified School District
Lucia Mar Unified School District
Luther Burbank School District
Lynwood Unified School District
Madera County Superintendent of Schools
Madera Unified School District
Magnolia Elementary School District
Magnolia Union Elementary School District
Mammoth Unified School District
Manchester Union Elementary School District
Manhattan Beach Unified School District
Manteca Unified School District
Manzanita Elementary School District
Maple Creek Elementary School District
Maple Elementary School District
Marcum-Illinois Union Elementary School District
Maricopa Unified School District
Marin County Office of Education
Mariposa County Office of Education
Mariposa County Unified School District
Mark Twain Union Elementary School District
Mark West Union Elementary School District
Martinez Unified School District
Marysville Joint Unified School District
Mattole Unified School District
Maxwell Unified School District
McCabe Union Elementary School District
McCloud Union Elementary School District
McFarland Unified School District
McKinleyville Union Elementary School District
McKittrick Elementary School District
McSwain Union Elementary School District
Meadows Union Elementary School District
Mendocino County Office of Education
Mendocino Unified School District
Mendota Unified School District
Menifee Union Elementary School District
Menlo Park City Elementary School District
Merced City Elementary School District
Merced County Office of Education
Merced River Union Elementary School District
Merced Union High School District
Meridian Elementary School District

Information for Bidders, Attachment #1

Mesa Union Elementary School District
Middletown Unified School District
Midway Elementary School District
Mill Valley Elementary School District
Millbrae Elementary School District
Millville Elementary School District
Milpitas Unified School District
Mission Union Elementary School District
Modesto City Schools
Modoc County Office of Education
Modoc Joint Unified School District
Mojave Unified School District
Mono County Office of Education
Monroe Elementary School District
Monrovia Unified School District
Monson-Sultana Joint Union Elementary School District
Montague Elementary School District
Monte Rio Union Elementary School District
Montebello Unified School District
Montecito Union Elementary School District
Monterey County Office of Education
Monterey Peninsula Unified School District
Montgomery Elementary School District
Moorpark Unified School District
Moraga Elementary School District
Moreland School District
Moreno Valley Unified School District
Morgan Hill Unified School District
Morongo Unified School District
Mother Lode Union Elementary School District
Mt Baldy Joint Elementary School District
Mount Diablo Unified School District
Mount Pleasant Elementary School District
Mount Shasta Union Elementary School District
Mountain Elementary School District
Mountain Empire Unified School District
Mountain House Elementary School District
Mountain Union Elementary School District
Mountain Valley Unified School District
Mountain View Elementary School District
Mountain View-Whisman School District
Mountain View-Los Altos Union High School District
Mulberry Elementary School District
Mupu Elementary School District
Muroc Joint Unified School District
Murrieta Valley Unified School District
Napa County Office of Education
Napa Valley Unified School District
National Elementary School District
Natomas Unified School District
Needles Unified School District
Nevada City Elementary School District
Nevada County Office of Education
Nevada Joint Union High School District
New Haven Unified School District
New Hope Elementary School District
New Jerusalem School District
Newark Unified School District
Newcastle Elementary School District
Newhall School District
Newman-Crows Landing Unified School District
Newport-Mesa Unified School District
Nicasio School District
Norris Elementary School District
North County Joint Union Elementary School District
North Cow Creek Elementary School District
North Monterey County Unified School District
North Sacramento Elementary School District
Northern Humboldt Union High School District
Norwalk LaMirada Unified School District
Novato Unified School District
Nuestro Elementary School District
Nuview Union School District
Oak Grove Elementary School District
Oak Grove Union Elementary School District
Oak Park Unified School District
Oak Run Elementary School District
Oak Valley Union Elementary School District
Oak View Union Elementary School District
Oakdale Joint Unified School District
Oakland Unified School District
Oakley Union Elementary School District
Ocean View School District (Orange)
Ocean View School District (Venura)
Oceanside Unified School District
Ojai Unified School District
Old Adobe Union School District
Ontario-Montclair School District
Ophir Elementary School District
Orange Center School District
Orange County Department of Education School District
Orange Unified School District
Orchard Elementary School District
Orcutt Union Elementary School District
Orick Elementary School District
Orinda Union Elementary School District
Orland Joint Unified School District
Oro Grande School District
Oroville City Elementary School District
Oroville Union High School District
Outside Creek Elementary School District
Owens Valley Unified School District
Oxnard School District
Oxnard Union High School District
Pacheco Union Elementary School District
Pacific Elementary School District
Pacific Grove Unified School District
Pacific Union Elementary School District
Pacifica School District
Pajaro Valley Unified School District
Palermo Union Elementary School District
Palm Springs Unified School District
Palmdale Elementary School District
Palo Alto Unified School District
Palo Verde Unified School District
Palo Verde Union Elementary School District
Palos Verdes Peninsula Unified School District
Panama-Buena Vista Union School District
Panoche Elementary School District
Paradise Elementary School District
Paradise Unified School District
Paramount Unified School District
Parlier Unified School District
Pasadena Unified School District
Paso Robles Joint Unified School District
Patterson Joint Unified School District
Peninsula Union School District
Perris Elementary School District
Perris Union High School District
Petaluma City Elementary School District
Petaluma Joint Union High School District
Piedmont City Unified School District
Pierce Joint Unified School District
Pine Ridge Elementary School District

Information for Bidders, Attachment #1

Piner-Olivet Union Elementary School District
Pioneer Union Elementary School District (Butte)
Pioneer Union Elementary School District (El Dorado)
Pioneer Union Elementary School District (Kings)
Pittsburg Unified School District
Pixley Union Elementary School District
Placentia-Yorba Linda Unified School District
Placer County Office of Education
Placer Hills Union Elementary School District
Placer Union High School District
Placerville Union Elementary School District
Plainsburg Union Elementary School District
Planada Elementary School District
Plaza Elementary School District
Pleasant Grove Joint Union School District
Pleasant Ridge Union School District
Pleasant Valley Joint Union Elementary School District
Pleasant Valley School District
Pleasant View Elementary School District
Pleasanton Unified School District
Plum Valley Elementary School District
Plumas County Office of Education
Plumas Lake Elementary School District
Plumas Unified School District
Point Arena Joint Union High School District
Pollock Pines Elementary School District
Pomona Unified School District
Pond Union Elementary School District
Pope Valley Union Elementary School District
Porterville Unified School District
Portola Valley Elementary School District
Potter Valley Community Unified School District
Poway Unified School District
Princeton Joint Unified School District
Raisin City Elementary School District
Ramona City Unified School District
Rancho Santa Fe Elementary School District
Ravendale-Termo Elementary School District
Ravenswood City Elementary School District
Raymond-Knowles Union Elementary School District
Ready Springs Union Elementary School District
Red Bluff Joint Union High School District
Red Bluff Union Elementary School District
Redding Elementary School District
Redlands Unified School District
Redondo Beach Unified School District
Redwood City Elementary School District
Reed Union Elementary School District
Reeds Creek Elementary School District
Reef-Sunset Unified School District
Rescue Union Elementary School District
Rialto Unified School District
Richfield Elementary School District
Richgrove Elementary School District
Richland Union Elementary School District
Richmond Elementary School District
Rim of The World Unified School District
Rincon Valley Union Elementary School District
Rio Bravo-Greeley Union Elementary School District
Rio Dell Elementary School District
Rio Elementary School District
Rio Linda Union Elementary School District
Ripon Unified School District
River Delta Joint Unified School District
Riverbank Unified School District
Riverdale Joint Unified School District
Riverside County Office of Education
Riverside Unified School District
Roberts Ferry Union Elementary School District
Robla Elementary School District
Rockford Elementary School District
Rocklin Unified School District
Rohnerville Elementary School District
Romoland Elementary School District
Rosedale Union Elementary School District
Roseland School District
Rosemead Elementary School District
Roseville City Elementary School District
Roseville Joint Union High School District
Ross Elementary School District
Ross Valley Elementary School District
Round Valley Joint Elementary School District
Round Valley Unified School District (California)
Rowland Unified School District
Sacramento City Unified School District
Sacramento County Office of Education
Saddleback Valley Unified School District
Salida Union Elementary School District
Salinas City Elementary School District
Salinas Union High School District
San Antonio Union Elementary School District
San Ardo Union Elementary School District
San Benito County Office of Education
San Benito High School District
San Bernardino City Unified School District
San Bernardino County Office of Education
San Bruno Park Elementary School District
San Carlos Elementary School District
San Diego County Office of Education
San Diego Unified School District
San Dieguito Union High School District
San Francisco County Office of Education
San Francisco Unified School District
San Gabriel Unified School District
San Jacinto Unified School District
San Joaquin County Office of Education
San Jose Unified School District
San Juan Unified School District
San Leandro Unified School District
San Lorenzo Unified School District
San Lorenzo Valley Unified School District
San Lucas Union Elementary School District
San Luis Coastal Unified School District
San Luis Obispo County Office of Education
San Marcos Unified School District
San Marino Unified School District
San Mateo County Office of Education
San Mateo Union High School District
San Mateo-Foster City School District
San Miguel Joint Union School District
San Pasqual Union Elementary School District
San Pasqual Valley Unified School District
San Rafael City Elementary School District
San Rafael City High School District
San Ramon Valley Unified School District
San Ysidro Elementary School District
Sanger Unified School District
Santa Ana Unified School District
Santa Barbara County Office of Education
Santa Barbara Unified School District
Santa Clara County Office of Education
Santa Clara Elementary School District
Santa Clara Unified School District
Santa Cruz City Elementary School District

Information for Bidders, Attachment #1

Santa Cruz City High School District
Santa Cruz County Office of Education
Santa Maria Joint Union High School District
Santa Maria-Bonita School District
Santa Monica-Malibu Unified School District
Santa Paula Elementary School District
Santa Paula Union High School District
Santa Rita Union Elementary School District
Santa Rosa City Schools
Santa Rosa Elementary School District
Santa Rosa High School District
Santa Ynez Valley Union High School District
Santee School District
Saratoga Union Elementary School District
Sausalito Elementary School District
Saugus Union School District
Sausalito Marin City School District
Savanna School District
Scotia Union Elementary School District
Scott Valley Unified School District
Scotts Valley Unified School District
Sebastopol Union Elementary School District
Seeley Union Elementary School District
Seiad Elementary School District
Selma Unified School District
Semitropic Elementary School District
Sequoia Union Elementary School District
Sequoia Union High School District
Shaffer Union Elementary School District
Shandon Joint Unified School District
Shasta County Office of Education
Shasta Union Elementary School District
Shasta Union High School District
Shiloh Elementary School District
Shoreline Unified School District
Sierra County Office of Education
Sierra Sands Unified School District
Sierra Unified School District
Sierra-Plumas Joint Unified School District
Silver Fork Elementary School District
Silver Valley Unified School District
Simi Valley Unified School District
Siskiyou County Office of Education
Siskiyou Union High School District
Snelling-Merced Falls Union Elementary School District
Snowline Joint Unified School District
Solana Beach Elementary School District
Solano County Office of Education
Soledad Unified School District
Solvang Elementary School District
Somis Union School District
Sonoma County Office of Education
Sonoma Valley Unified School District
Sonora Elementary School District
Sonora Union High School District
Soquel Union Elementary School District
Soulsbyville Elementary School District
South Bay Union School District
South Fork Union School District
South Monterey County Joint Union High School District
South Pasadena Unified School District
South San Francisco Unified School District
South Whittier Elementary School District
Southern Humboldt Joint Unified School District
Southern Kern Unified School District
Southern Trinity Joint Unified School District
Southside Elementary School District
Spencer Valley Elementary School District
Spreckels Union Elementary School District
Springville Union Elementary School District
St. Helena Unified School District
Standard Elementary School District
Stanislaus County Office of Education
Stanislaus Union Elementary School District
Stockton Unified School District
Stone Corral Elementary School District
Stony Creek Joint Unified School District
Strathmore Union Elementary School District
Sulphur Springs Union School District
Summerville Elementary School District
Summerville Union High School District
Sundale Union Elementary School District
Sunnyside Union Elementary School District
Sunnyvale School District
Sunol Glen Unified School District
Surprise Valley Joint Unified School District
Susanville Elementary School District
Sutter County Office of Education
Sutter Union High School District
Sweetwater Union High School District
Sylvan Union Elementary School District
Taft City School District
Taft Union High School District
Tahoe-Truckee Joint Unified School District
Tamalpais Union High School District
Tehachapi Unified School District
Tehama County Office of Education
Temecula Valley Unified School District
Temple City Unified School District
Templeton Unified School District
Terra Bella Union Elementary School District
Thermalito Union Elementary School District
Three Rivers Union Elementary School District
Tipton Elementary School District
Torrance Unified School District
Tracy Joint Unified School District
Traver Joint Elementary School District
Travis Unified School District
Tres Pinos Union Elementary School District
Trinidad Union Elementary School District
Trinity Alps Unified School District
Trinity Center Elementary School District
Trinity County Office of Education
Trona Joint Unified School District
Tulare City School District
Tulare County Office of Education
Tulare Joint Union High School District
Tulelake Basin Joint Unified School District
Tuolumne County Superintendent of Schools
Turlock Unified School District
Tustin Unified School District
Twain Harte School District
Twin Hills Union Elementary School District
Twin Ridges Elementary School District
Two Rock Union School District
Ukiah Unified School District
Union Elementary School District
Union Hill Elementary School District
Union Joint Elementary School District
Upland Unified School District
Upper Lake Unified School District
Vacaville Unified School District
Val Verde Unified School District
Valle Lindo Elementary School District

Information for Bidders, Attachment #1

Vallecito Union School District
Vallecitos Elementary School District
Vallejo City Unified School District
Valley Center-Pauma Unified School District
Valley Home Joint Elementary School District
Ventura County Office of Education
Ventura Unified School District
Victor Elementary School District
Victor Valley Union High School District
Vineland Elementary School District
Visalia Unified School District
Vista Del Mar Union School District
Vista Unified School District
Walnut Creek Elementary School District
Walnut Valley Unified School District
Warner Unified School District
Wasco Union Elementary School District
Wasco Union High School District
Washington Colony Elementary School District
Washington Unified School District
Washington Union Elementary School District
Washington Union High School District
Waterford Unified School District
Waugh Elementary School District
Waukena Joint Union Elementary School District
Weaver Union School District
Weaverville Elementary School District
Weed Union Elementary School District
West Contra Costa Unified School District
West Covina Unified School District
West Fresno Elementary School District
West Park Elementary School District
West Side Union Elementary School District
West Sonoma County Union High School District
Western Placer Unified School District
Westminster School District
Westmorland Union Elementary School District
Westside Elementary School District
Westside Union Elementary School District
Westwood Unified School District
Wheatland School District
Wheatland Union High School District
Whitmore Union Elementary School District
Whittier City Elementary School District
Whittier Union High School District
William S. Hart Union High School District
Williams Unified School District
Willits Unified School District
Willow Creek Elementary School District
Willow Grove Union Elementary School District
Willows Unified School District
Wilmar Union Elementary School District
Wilsona Elementary School District
Windsor Unified School District
Winship-Robbins School District
Winters Joint Unified School District
Winton School District
Wiseburn Unified School District
Woodlake Unified School District
Woodland Joint Unified School District
Woodside Elementary School District
Woodville Union Elementary School District
Wright Elementary School District
Yolo County Office of Education
Yosemite Unified School District
Yreka Union School District
Yreka Union High School District

Yuba City Unified School District
Yuba County Office of Education
Yucaipa-Calimesa Joint Unified School District

Community Colleges (alphabetical)

Allan Hancock College
American Academy of Dramatic Arts
American River College
Antelope Valley College
Bakersfield College
Barstow Community College
Berkeley City College
Butte College
Cabrillo College
Canada College
Cerritos College
Cerro Coso Community College
Chabot College
Chaffey College
Citrus College
City College of San Francisco
Coastline Community College
College of Alameda
College of Marin
College of San Mateo
College of the Canyons
College of the Desert
College of the Redwoods
College of the Sequoias
College of the Siskiyous
Columbia College
Contra Costa College
Copper Mountain College
Cosumnes River College
Crafton Hills College
Cuesta College
Cuyamaca College
Cypress College
De Anza College
Diablo Valley College
Deep Springs College
Defense Language Institute
East Los Angeles College
El Camino College
Evergreen Valley College
Fashion Institute of Design & Merchandising
Feather River College
Folsom Lake College
Foothill College
Fresno City College
Fullerton College
Gavilan College
Glendale Community College
Golden West College
Grossmont College
Hartnell College
Heald College (Nursing)
Imperial Valley College
Irvine Valley College
Lake Tahoe Community College
Laney College
Las Positas College
Lassen College
Long Beach City College
Los Angeles City College

Information for Bidders, Attachment #1

Los Angeles Harbor College
Los Angeles Mission College
Los Angeles Pierce College
Los Angeles Southwest College
Los Angeles Trade-Technical College
Los Angeles Valley College
Los Angeles County College of Nursing & Allied Health
Los Medanos College
Marymount College
Mendocino College
Merced College
Merritt College
Mira Costa College
Mission College
Modesto Junior College
Monterey Peninsula College
Moorpark College
Moreno Valley College
Mount San Antonio College
Mount San Jacinto College
MTI College of Business & Technology
Napa Valley College
National Polytechnic College of Science
Norco Campus
Ohlone College
Orange Coast College
Oxnard College
Palo Verde College
Palomar College
Pasadena City College
Porterville College
Reedley College
Rio Hondo College
Riverside City College
Sacramento City College
Saddleback College
San Bernardino Valley College
San Diego City College
San Diego Mesa College
San Diego Miramar College
San Joaquin Delta College
San Jose City College
Santa Ana College
Santa Barbara City College
Santa Monica College
Santa Rosa Junior College
Santiago Canyon College
Shasta College
Sierra College
Skyline College
Solano Community College
Southwestern College
Taft College
Ventura College
Victor Valley College
West Hills Community College
West Los Angeles College
West Valley College
Woodland Community College
Yuba College

California State Universities (alphabetical)

California Maritime Academy
California Polytechnic State University, San Luis Obispo
California State Polytechnic University, Pomona
California State University Bakersfield
California State University Channel Islands
California State University Chico
California State University Dominguez Hills
California State University East Bay
California State University Fresno
California State University Fullerton
California State University Long Beach
California State University Los Angeles
California State University Monterey Bay
California State University Northridge
California State University Sacramento
California State University San Bernardino
California State University San Marcos
California State University Stanislaus
Humboldt State University
San Diego State University
San Francisco State University
San Jose State University
Sonoma State University

California UC Campuses (alphabetical)

Berkeley
Davis
Irvine
Los Angeles
Merced
Riverside
San Diego
San Francisco
Santa Barbara
Santa Cruz

BID FORM - 1

Name of Bidder: Elite Modular Leasing and Sales, Inc.
To: Savanna School District, acting by and through its Governing Board, herein called the "DISTRICT."

1. The undersigned Bidder, having become familiarized with all the following documents including but not limited to the Notice Calling for Bids, Information for Bidders, Bid Forms 1 and 2 (Attachments A & B), Bid Security, Information required of Bidder, Designation of Subcontractors Form, Request for Substitution at Time of Bid, Non-collusion Affidavit, Iran Contracting Act Certification, Agreement, Faithful Performance Bond, Payment Bond, Drug Free Certification, Workers Compensation Certification, Criminal Records Check Certification, Guarantee, Contractors Certificate Regarding Non-Asbestos, Tobacco Free Workplace Certificate, Lead-Containing Materials Certification, Disabled Veterans Business Enterprise (DVBE) Certification, Escrow Agreement, all insurance requirements, Change Order Forms, Contractors Request for Inspection, Request for Information (RFI) Forms, Shop Drawing Transmittal Form, General Conditions and Supplementary General Conditions, specifications, and all modifications, addenda and amendments, if any (hereinafter Project Documents), the local conditions affecting the performance of the work and the cost of the work at the place where the work is to be done, hereby proposes and agrees to be bound by all the terms and conditions of the Project Documents and agrees to perform, within the time stipulated, the work, including all of its component parts, and everything required to be performed, and to provide and furnish and pay for any and all of the labor, materials, tools, expendable equipment, and all applicable taxes, disposal fees, utility and transportation services necessary to perform the work and complete in a good workmanlike manner all of the work required in accordance with laws, codes, regulations, ordinances and any other legal requirements governing the work, in connection with the following:

Project: 2021 District-Wide Contract for the Purchase, Lease,
Relocation, Dismantling, and Removal of Division of
the State Architect (DSA) Approved Portable Buildings

Project No.: SSPU, #40-04/2020-21

all in strict conformity with the Project Documents, including Addenda Nos. # 1, 2, 3 and _____, on file at the Administrative Office of said DISTRICT for the sum of: Not Applicable Dollars (\$ N.A.). The bidder agrees to provide each item listed under the attached Bid Form 2: Schedule of Unit Costs including all attachments for the price indicated. The quantity on which to indicate each price shall be one unit unless specifically noted otherwise. All items shall be complete including applicable delivery, installation, taxes, and miscellaneous costs, unless specifically noted otherwise.

Each individual bid price shall be determined from reviewing the specifications and all portions of the Project Documents, and shall include all items necessary to complete the work, including the assumption of all obligations, duties, and responsibilities necessary to the successful completion of the Project, and the furnishing of all materials and equipment required to be incorporated in and form a permanent part of the work, and the furnishing of tools, equipment, supplies, transportation, disposal fees, facilities, labor, superintendence, and services required to perform and complete the work, all as per the requirements of the Project Documents, whether or not expressly listed or designated.

2. It is understood that the DISTRICT reserves the right to reject any or all bids or to waive any irregularities or informalities in any bids or in the bidding process. Bidder agrees that this bid shall remain open and not be withdrawn for the period specified in the Information for Bidders.

3. The required bid security is attached.

4. The required list(s) of proposed subcontractors is attached hereto, and the undersigned represents and warrants that such list(s) is complete and in compliance with the Subletting and Subcontracting Fair Practices Act. Public Contract Code Sections 4100, et seq.

5. It is understood and agreed that if written notice of the award of a contract is mailed, faxed, or delivered to the bidder, the bidder will execute and deliver to the DISTRICT the Agreement within five (5) days and will also furnish and deliver to the DISTRICT the Faithful Performance Bond and a separate Payment Bond (when Bonds are specifically included in the line item project scope and cost.) as specified, and certificates and endorsements of insurance, the Workers' Compensation Certificate, Drug-Free Work Place Certification, the Criminal Records Check Certification, Contractor's Certificate Regarding Non-Asbestos Containing Materials, within five (5) working days of the notice of award of the contract, or as otherwise requested in writing by the DISTRICT. It is understood that should bidder fail or refuse to return these documents as required by the DISTRICT, the bid security shall be forfeited to the DISTRICT. The bidder further agrees that the work shall be commenced by the bidder, if awarded the contract, on or before one (1) day after receiving the DISTRICT's Notice to Proceed, and shall be completed by the bidder in the time specified by the DISTRICT.

6. Communications conveying notice of award of the contract, requests for additional information or other correspondence should be addressed to the bidder at the address stated below.

7. The name(s) of all persons interested in the bid as principals are as follows:

Jeremy Goldenetz, President
Michael Rhodes, Secretary
Brett Barkaw, CEO.

8. In submitting this bid, the bidder offers and agrees that if the bid is accepted, it will assign to DISTRICT all rights, title and interest in and to all causes of action it may have under Section 4 of the Clayton Act (15 U.S.C. Section 15) or under the Cartwright Act (Business & Professions Code Section 16700, et seq.) arising from purchases of goods, materials, or services by the bidder for sale to the DISTRICT pursuant to the bid. Such assignment shall be made and become effective at the time the DISTRICT tenders final payment under the contract. (Public Contract Code Section 7103.5; Government Code Section 4450, 4451 and 4552).

9. The undersigned hereby warrants that the bidder has an appropriate license, License No. 1020113, Class B, at the time of the bid opening, that such license entitles bidder to provide the work, that such license will be in full force and effect throughout the duration of performance of this Project. Bidder shall be nonresponsive if the Bidder is not licensed as required by the DISTRICT at the time of the bid opening. Any and all subcontractors to be employed by the undersigned shall have appropriate licenses at the time of the bid opening.

10. The bidder hereby certifies that it is, and at all times during the performance of work hereunder shall be, in full compliance with the provisions of the Immigration Reform and Control Act of 1986 ("IRCA") in the hiring of its employees, and the bidder shall indemnify, hold harmless and defend the DISTRICT against any and all actions, proceedings, penalties or claims arising out of the bidder's failure to comply strictly with the IRCA.

11. It is understood and agreed that if requested by the DISTRICT, the bidder shall furnish a notarized financial statement, references, and other information required by the DISTRICT sufficiently comprehensive to permit an appraisal of bidder's ability to perform the Project.

12. The undersigned hereby warrants that all work shall be completed within the number of consecutive calendar days (including all punchlist items) negotiated between the District and the successful Bidder for each individual project (purchase order) initiated under this unit price bid from the date specified on the Notice to Proceed. As indicated in the Information for Bidders, Article 5, Contract Schedule, no schedule shall exceed 180 consecutive Calendar days, unless negotiated and documented. The timeline shall be documented in each and every purchase order. The undersigned agrees that failure to complete the work within the time set forth in each purchase order will result in the imposition of liquidated damages for each consecutive calendar day of delay in the amount of five-hundred Dollars (\$500.00). (Government Code Section 53069.85)

13. The required noncollusion affidavit properly notarized is attached as required by Public Contract Code Section 7106. Bidder understands and agrees that failure to submit a completed and signed affidavit will render the bidder automatically nonresponsive.

14. It is understood and agreed that all change order requests must be submitted in the form set forth in the Project Documents and pursuant to Article 57 of the General Conditions. The amount of allowable charges submitted pursuant to a change order shall be limited to the charges allowed under Article 57 of the General Conditions. Indirect, consequential and incidental costs, project management costs, extended home office and field office overhead, administrative costs and profit and other charges not specifically authorized under Article 57 of the General Conditions will not be allowed.

15. The Information Required of Bidder Form has been fully completed and is attached hereto.

16. The Request for Substitution at Time of Bid Form has been fully completed and is attached hereto.

17. The Iran Contracting Act Certification Form has been fully completed and is attached hereto.

18. All of Bid Form-2 including attachments shall be incorporated herein as if fully set forth.

The undersigned hereby declares that all of the representations of this bid are made under penalty of perjury under the laws of the State of California.

Individual Name: _____ **N/A**
Signed _____ by:

Print Name: _____
Date: _____
Business Address: _____

Telephone: _____

Partnership Name: _____ NIA

Signed _____ by:

Print Name: _____

Date: _____

Business Address: _____

Telephone: _____

Other Partner(s): _____

Corporation Name: Elite Modular Leasing and Sales, Inc.
(a S Corporation¹)

Business Address: 3091 Indian Ave
Perris, CA 92571

Telephone: 951-422-2500

Signed by: [Signature], President, Date: 12/9/2020

Print Name: Seremy Goldenetz - President

Signed by: [Signature], Secretary, Date: 12/9/2020

Print Name: Michael Rhodes, Secretary
[Seal]

Joint Venturer

Name: _____ NIA

Signed by: _____, Joint Venturer

Print Name: _____

Date: _____

Business Address: _____

¹ A corporation awarded the contract shall furnish evidence of its corporate existence and evidence that the officer signing the Agreement and bonds is duly authorized to do so.

Other Parties to
Joint Venture:

Telephone: _____

If an individual: _____ **N/A**
(Name)

Signed by: _____

Print Name: _____

Date: _____

Doing Business as: _____

Business Address: _____

Telephone: _____

If a Partnership: _____ **N/A**
(Name)

Signed by: _____, Partner

Print Name: _____

Date: _____

Business Address: _____

Telephone: _____

If a Corporation: _____ **N/A**
(a _____ Corporation)

Signed By: _____ Date: _____

Print Name: _____

Title: _____

Date: _____

Business Address: _____

Telephone: _____

BID BOND – Number N/A

KNOW ALL PERSONS BY THESE PRESENT, that we Elite Modular Leasing and Sales, Inc., as Principal, and Philadelphia Indemnity Insurance Company as Surety, a California admitted surety insurer, are held and firmly bound unto the Savanna School District, hereinafter called the DISTRICT, in the sum of one hundred thousand dollars (\$100,000.00) estimated to be ten PERCENT (10%) OF THE LARGEST SINGLE PROJECT PURCHASE ORDER THAT MAY BE ISSUED BY THE DISTRICT on the Master Contract within any one contract year, of the Principal, submitted to the said DISTRICT for the work described below for the payment of which sum in lawful money of the United States, well and truly to be made, we jointly and severally bind ourselves, our heirs, executors, administrators, successors and assigns.

The condition of this obligation is such that whereas the Principal has submitted the accompanying bid dated December 11, 2020, for the 2021 District-Wide Contract for the Purchase, Lease, Relocate, Dismantling, and Removal of Division of the State (DSA) Approved Portable Buildings, Project No. SSPU, #40-04/2020-21.

NOW, THEREFORE, if the Principal shall not withdraw said bid within the period specified therein after the opening of the same, or, if no period be specified, within ninety (90) days after said opening; and if the Principal is awarded the contract, and shall within the period specified therefore, or, if no period be specified, within five (5) working days after the notice of award of the contract, or as otherwise requested in writing by the DISTRICT, enter into a written contract with the DISTRICT, in accordance with the bid as accepted and give bonds with good and sufficient surety or sureties, as may be required for the faithful performance and proper fulfillment of such contract and for the payment for labor and materials used for the performance of the contract, furnish certificates and endorsements evidencing the required insurance is in effect and furnish and deliver to the DISTRICT the Workers' Compensation Certificate, Drug-Free Work Place Certification, the Criminal Records Check Certification, Contractor's Certificate Regarding Non-Asbestos Containing Materials, Guarantee, Tobacco Free Work Place Certification, Lead-Containing Materials and Notice Certification, Disabled Veterans Business Enterprise (DVBE) Certification within Five (5) days, then the above obligation shall be void and of no effect, otherwise the bond amount shall be forfeited to the DISTRICT.

Surety, for value received, hereby stipulates and agrees that no change, extension of time, alteration or addition to the terms of the contract or the call for bids, or to the work to be performed thereunder, or the specifications accompanying the same, shall in any way affect its obligation under this bond, and it does hereby waive notice of any such change, extension of time, alteration or addition to the terms of said contract or the call for bids, or to the work, or to the specifications.

In the event suit is brought upon this bond by the DISTRICT and judgment is recovered, the Surety shall pay all costs incurred by the DISTRICT in such suit, including reasonable attorney's fees to be fixed by the court.

IN WITNESS HEREOF, the parties have executed this bond under their several seals this day of December 3, 2020, the name and corporate seal of each corporate party being hereto affixed and duly signed by its undersigned authorized representative.

(Corporate Seal of
Principal, if
Corporation)

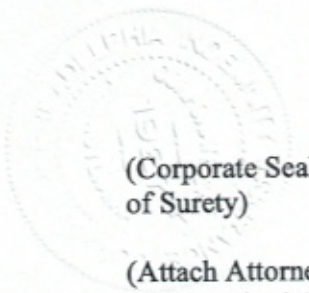
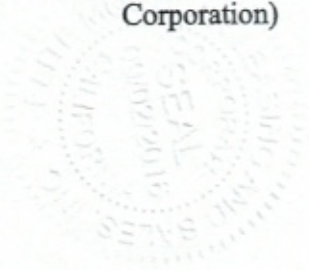

(Corporate Seal
of Surety)

(Attach Attorney-in-Fact Certificate
and Required Acknowledgements)

Contact Data For Local Agent:

By:
Signature

Sierra Summit Surety Insurance Services, Inc.
Print Name

President / CEO
Title

1040 Nevada St., Ste. 302, Redlands, CA 92374
Address

(909) 919-2432
Telephone No.

Elite Modular Leasing and Sales, Inc.
Principal (Proper Name of Bidder)

By:
Signature

Jeremy Goldenetz
Print Name

President
Title

Philadelphia Indemnity Insurance Company
Surety

By:
Signature

R.E. Gail
Print Name

Attorney-in-Fact
Title

800 E. Colorado Blvd. 6th Floor, Pasadena, CA 91101
Address

(626) 639-1321
Telephone No.

(626) 578-9225
Facsimile No.

CALIFORNIA ALL- PURPOSE CERTIFICATE OF ACKNOWLEDGMENT

A notary public or other officer completing this certificate verifies only the identity of the individual who signed the document to which this certificate is attached, and not the truthfulness, accuracy, or validity of that document.

State of California }

County of San Bernardino }

On DEC 03 2020 before me, Brendan Gail, Notary Public
(Here insert name and title of the officer)

personally appeared R.E. Gail,
who proved to me on the basis of satisfactory evidence to be the person(s) whose name(s) is/are subscribed to the within instrument and acknowledged to me that he/~~she/they~~ executed the same in his/~~her/their~~ authorized capacity(ies), and that by his/~~her/their~~ signature(s) on the instrument the person(s), or the entity upon behalf of which the person(s) acted, executed the instrument.

I certify under PENALTY OF PERJURY under the laws of the State of California that the foregoing paragraph is true and correct.

WITNESS my hand and official seal.

Brendan Gail

Notary Public Signature

(Notary Public Seal)



ADDITIONAL OPTIONAL INFORMATION

DESCRIPTION OF THE ATTACHED DOCUMENT

(Title or description of attached document)

(Title or description of attached document continued)

Number of Pages _____ Document Date _____

CAPACITY CLAIMED BY THE SIGNER

- Individual (s)
 Corporate Officer

(Title)

- Partner(s)
 Attorney-in-Fact
 Trustee(s)
 Other _____

INSTRUCTIONS FOR COMPLETING THIS FORM

This form complies with current California statutes regarding notary wording and, if needed, should be completed and attached to the document. Acknowledgments from other states may be completed for documents being sent to that state so long as the wording does not require the California notary to violate California notary law.

- State and County information must be the State and County where the document signer(s) personally appeared before the notary public for acknowledgment.
- Date of notarization must be the date that the signer(s) personally appeared which must also be the same date the acknowledgment is completed.
- The notary public must print his or her name as it appears within his or her commission followed by a comma and then your title (notary public).
- Print the name(s) of document signer(s) who personally appear at the time of notarization.
- Indicate the correct singular or plural forms by crossing off incorrect forms (i.e. ~~he/she/they~~, is /are) or circling the correct forms. Failure to correctly indicate this information may lead to rejection of document recording.
- The notary seal impression must be clear and photographically reproducible. Impression must not cover text or lines. If seal impression smudges, re-seal if a sufficient area permits, otherwise complete a different acknowledgment form.
- Signature of the notary public must match the signature on file with the office of the county clerk.
 - ❖ Additional information is not required but could help to ensure this acknowledgment is not misused or attached to a different document.
 - ❖ Indicate title or type of attached document, number of pages and date.
 - ❖ Indicate the capacity claimed by the signer. If the claimed capacity is a corporate officer, indicate the title (i.e. CEO, CFO, Secretary).
- Securely attach this document to the signed document with a staple.

PHILADELPHIA INDEMNITY INSURANCE COMPANY
One Bala Plaza, Suite 100
Bala Cynwyd, PA 19004-0950

Power of Attorney

KNOW ALL PERSONS BY THESE PRESENTS: That **PHILADELPHIA INDEMNITY INSURANCE COMPANY** (the Company), a corporation organized and existing under the laws of the Commonwealth of Pennsylvania, does hereby constitute and appoint **R. E. Gail of Sierra Summit Surety Insurance Services, Inc.**, its true and lawful Attorney-in-fact with full authority to execute on its behalf bonds, undertakings, recognizances and other contracts of indemnity and writings obligatory in the nature thereof, issued in the course of its business and to bind the Company thereby, in an amount not to exceed **\$25,000,000.00**.

This Power of Attorney is granted and is signed and sealed by facsimile under and by the authority of the following Resolution adopted by the Board of Directors of **PHILADELPHIA INDEMNITY INSURANCE COMPANY** on the 14th of November, 2016.

RESOLVED: That the Board of Directors hereby authorizes the President or any Vice President of the Company: (1) Appoint Attorney(s) in Fact and authorize the Attorney(s) in Fact to execute on behalf of the Company bonds and undertakings, contracts of indemnity and other writings obligatory in the nature thereof and to attach the seal of the Company thereto; and (2) to remove, at any time, any such Attorney-in-Fact and revoke the authority given. And, be it

FURTHER RESOLVED: That the signatures of such officers and the seal of the Company may be affixed to any such Power of Attorney or certificate relating thereto by facsimile, and any such Power of Attorney so executed and certified by facsimile signatures and facsimile seal shall be valid and binding upon the Company in the future with respect to any bond or undertaking to which it is attached.

IN TESTIMONY WHEREOF, **PHILADELPHIA INDEMNITY INSURANCE COMPANY** HAS CAUSED THIS INSTRUMENT TO BE SIGNED AND ITS CORPORATE SEAL TO BE AFFIXED BY ITS AUTHORIZED OFFICE THIS 27TH DAY OF OCTOBER, 2017.



(Seal)

Robert D. O'Leary Jr., President & CEO
Philadelphia Indemnity Insurance Company

On this 27th day of October, 2017, before me came the individual who executed the preceding instrument, to me personally known, and being by me duly sworn said that he is the therein described and authorized officer of the **PHILADELPHIA INDEMNITY INSURANCE COMPANY**; that the seal affixed to said instrument is the Corporate seal of said Company; that the said Corporate Seal and his signature were duly affixed.

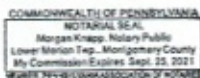

(Notary Seal)

Notary Public: Morgan Knapp
residing at: Bala Cynwyd, PA
My commission expires: September 25, 2021

I, Edward Sayago, Corporate Secretary of **PHILADELPHIA INDEMNITY INSURANCE COMPANY**, do hereby certify that the foregoing resolution of the Board of Directors and the Power of Attorney issued pursuant thereto on the 27th day of October, 2017 are true and correct and are still in full force and effect. I do further certify that Robert D. O'Leary Jr., who executed the Power of Attorney as President, was on the date of execution of the attached Power of Attorney the duly elected President of **PHILADELPHIA INDEMNITY INSURANCE COMPANY**.

In Testimony Whereof I have subscribed my name and affixed the facsimile seal of each Company this _____ day of **DEC 03 2020**.



Edward Sayago, Corporate Secretary
PHILADELPHIA INDEMNITY INSURANCE COMPANY



INFORMATION REQUIRED OF BIDDER

The Bidder shall furnish all the following information. Bidder shall carefully read and answer all questions to ensure completeness and accuracy. Failure to comply with this requirement may cause rejection of the bid. Additional sheets may be attached if necessary. "You" or "your" as used herein refers to the bidder and any of its owners, officers, directors, shareholders, principals, responsible managing officer (RMO) or responsible managing employee (RME). DISTRICT has discretion to request additional information depending on the Project.

- (1) Bidder name and address (Post Office Box Number not sufficient):
Elite Modular Leasing and Sales, Inc.
3091 Indian Ave
Perris, CA 92571
- (2) Telephone: 951-422-2500 Fax No.: _____
Electronic Mail: Jeremy@elitemodular.net
- (3) Individual _____ Partnership _____ Corporation Joint Venture _____ (check one)
- (4) Bidder's License No. 1020113 Class: B
License Expiration Date 11/30/2020
Name of License holder Elite Modular Leasing and Sales, Inc.
- (5) Have you ever been licensed under a different name or different license number?
Yes _____ No If "Yes," give name and license number.

- (6) Names and titles of all your owners, officers, principals, responsible managing officers and responsible managing employees:
- | | |
|-------------------------|------------------|
| <u>Jeremy Goldenetz</u> | <u>President</u> |
| Name | Title |
| <u>Michael Rhoades</u> | <u>Secretary</u> |
| <u>Brett Beshaw</u> | <u>C.E.O.</u> |
- (7) Number of years as a contractor in this type of construction work: 34

(8) Person who attended the mandatory pre-bid conference:

Name and Title: Jeremy Goldenetz, President

(9) How many years experience have you had in portable building school construction work under the jurisdiction of DSA?

(a) as a general contractor? 34

(b) as a subcontractor? 34

(10) How many years experience have you had in public construction work?

(a) as a general contractor? 34

(b) as a subcontractor? 34

(11) Have you ever been terminated from a school or any public construction project prior to the completion of the project? Yes No If the answer is "Yes," give dates, names and addresses of school/public agency and details.

(12) Have you ever been barred from bidding on any school or public construction project? Yes No If the answer is "Yes," give dates, names and addresses of school/public agency and details.

(13) Have you ever defaulted on any school or public construction project that resulted in a claim to a surety? Yes No If the answer is "Yes," give dates, names and addresses of school/public agency and details.

(14) Have you been assessed damages (i.e., liquidated damages) for any public construction project in the past ten (10) years? Yes ___ No If the answer is "Yes," give dates, names, and addresses of public agency and details. _____

(15) Have you ever brought any claim(s) against a public agency? Yes ___ No If the answer is "Yes," please explain in detail name of public agency, nature of the claim and outcome. _____

(16) Have you ever failed to complete a school or public construction project in the last ten (10) years? Yes ___ No If the answer is "Yes," provide name of public agency and details. _____

(17) Have you been in litigation or arbitration or dispute of any kind on a question or questions relating to a public construction project during the past ten (10) years? Yes ___ No If the answer is "Yes," provide name of public agency and details. _____

(18) List the names, addresses and telephone numbers of three Architects or Engineers whose DSA regulated, public construction jobs you have worked on in the past three (3) years.

<u>Individual</u>	<u>Company</u>	<u>Telephone</u>	<u>Email</u>
<u>David Bannon</u>	<u>GIBA Architects</u>	<u>(714) 665-8030</u>	<u>dbannon@gbaarchitects.net</u>
<u>Scott Gaudineer</u>	<u>Flewelling & Moody</u>	<u>(323) 543-8300</u>	<u>sgaudineer@flewellin-moody.com</u>
<u>Kevin Fleming</u>	<u>DLR Group</u>	<u>(849) 285-2427</u>	<u>kffleming@dlrgrp.com</u>

(19) Do you now or have you ever had any direct or indirect business, financial or other connection with any officer, employee or consultant of the DISTRICT or Program Manager?

Yes ___ No If so, please elaborate.

(20) List at least five (5) of your most recently completed school construction projects.

- (1) Santa Maria Joint Union HSD
- (2) College for Certain
- (3) Savanna SD
- (4) Downey USD
- (5) Bakersfield City SD

(21) List any other portable building projects for which you are currently under contract. (Provide additional sheets if needed.)

- (1) Kern County S.D.S.
- (2) Pomona USD
- (3) Bakersfield City SD
- (4) Long Beach USD
- (5) _____
- (6) _____
- (7) _____
- (8) _____
- (9) _____
- (10) _____

(22) List of References – DSA Approved Portable Building Public construction projects of similar nature in a school/community college/university within the last three (3) years. DISTRICT has discretion to require more than five (5) references.

1. Name: Kern County S.D.S.
Address, Telephone, and Email: 2000 K Street, Bakersfield, CA 93301
Contact Person: Sherrie Grober 661-636-4577 shgrober@kern.org
Description of Project: Purchase of Modular Buildings (New)

Dates of commencement and completion of Project: May 2019 - Dec 2020

Contract Amount: \$2,549,270.00

Architect: Carl G Elliott

Architect's Company, Telephone, and Email: Carl G Elliott

661-619-6478 celliott@bak.rr.com

DSA or public agency inspector: Fredrick Reyes

Telephone, and Email: 951-204-7709 reyes.fredrick@att.net

2. Name: Romona USD
Address, Telephone, and Email: 800 S. Garey Ave, Romona, CA 91766
909-552-3134 trevor@lcc3.com
Contact Person: Trevor Mason
Description of Project: Purchase of Custom Modular Buildings (New)
Dates of commencement and completion of Project: Jan 2018 - July 2018

Contract Amount: \$1,095,062.00

Architect: Steven Fader

Architect's Company, Telephone, and Email: Steven Fader Architects

323-376-1105 sfader@stevenfaderarchitects.com

DSA or public agency inspector: Fredrick Reyes

Telephone, and Email: 951-204-7709 reyes.fredrick@att.net

3. Name: Santa Maria Joint Union HSD
Address, Telephone, and Email: 2560 Skyway Dr, Santa Maria, CA 93455
Contact Person: Gary Wuitschick 805-922-4573 x4805 gwuitschick@smjhsd.net
Description of Project: Lease of Refurbished Modular Buildings
Dates of commencement and completion of Project: March 2020 - Aug 2020

Contract Amount: \$435,942.08

Architect: Len Metcalf

Architect's Company, Telephone, and Email: Rachlin Partners

310-204-3400 lmetcalf@rachlinpartners.com

DSA or public agency inspector: by district

Telephone, and Email: _____

4. Name: Oxnard Union HSD
 Address, Telephone, and Email: 309 S. K Street, Oxnard, CA 93030
 Contact Person: Paul Hansen 805-385-2683 paul.hansen@oxnardunion.org
 Description of Project: Lease of Refurbished Modular Buildings
 Dates of commencement and completion of Project: Jan 2020 - Sept 2020
-
- Contract Amount: \$290,000.00
 Architect: Tony Wong
 Architect's Company, Telephone, and Email: DC Architects
909-985-6939 x104 twong@dcarchitects.net
 DSA or public agency inspector: by district
 Telephone, and Email: _____
5. Name: Long Beach USD
 Address, Telephone, and Email: 2425 Webster Ave, Long Beach, CA 90810
 Contact Person: Ferdows Fazeli 562-997-7550 ffazeli@16schools.net
 Description of Project: Purchase of Leased Modular Buildings
 Dates of commencement and completion of Project: March 2019 - May 2019
-
- Contract Amount: \$772,644.00
 Architect: Mark Eacrett
 Architect's Company, Telephone, and Email: PBK
909-937-9200
 DSA or public agency inspector: Fredrick Reyes
 Telephone, and Email: 951-204-7709 reyes.fredrick@att.net

I certify and declare under penalty of perjury under the laws of the State of California that the foregoing responses to the Information Required of Bidder are true and correct.



Signature

Jeremy Goldenetz

Print Name

Resident

Title

12/9/2020

Date

DESIGNATION OF SUBCONTRACTORS

In compliance with the Subletting and Subcontracting Fair Practices Act (Public Contract Code Section 4100 et. seq.) and any amendments thereof, each bidder shall set forth below: (a) the name and the location of the place of business of each subcontractor who will perform work or labor or render service to the bidder (prime contractor) in or about the construction of the work or improvement to be performed under this contract or a subcontractor licensed by the State of California who, under subcontract to the bidder (prime contractor), specially fabricates and installs a portion of the work or improvement according to detailed drawings contained in the plans and specifications in an amount in excess of one-half of one percent of the bidder's (prime contractor's) total bid and (b) the portion of the work which will be done by each subcontractor. The bidder (prime contractor) shall list only one subcontractor for each such portion as is defined by the bidder (prime contractor) in this bid. This includes the requirement to list 3rd tier sub-contractors, or "subs of subs."

Since this is a unit bid format with many line items, Bidders must list sub-contractors for all items/trades included in the potential scope of the contract line items included on Bid Form-2.

Note that per the Information for Bidders, the Bidder and all listed sub-contractors must be registered with the Department of Industrial Relations (DIR) and be compliant with all program guidelines on prevailing wage submittals and monitoring activities.

If a bidder (prime contractor) fails to specify a subcontractor or if a bidder (prime contractor) specifies more than one subcontractor for the same portion of work to be performed under the contract in excess of one-half of one percent of the bidder's (prime contractor's) total bid, bidder shall be deemed to have agreed that bidder is fully qualified to perform that portion, and that bidder alone shall perform that portion. Violation of this requirement (including the procurement of a subcontractor for the Project if no subcontractor is specified) can result in the DISTRICT invoking the remedies of Public Contract Code Sections 4110 and 4111.

No bidder (prime contractor) whose bid is accepted shall (a) substitute any subcontractor, (b) permit any subcontractor to be voluntarily assigned or transferred or allow it to be performed by any one other than the original subcontractor listed in the original bid, or (c) sublet or subcontract any portion of the work in excess of one-half of one percent of the bidder's (prime contractor's) total bid as to which the original bid did not designate a subcontractor, except as authorized in the Subletting and Subcontracting Fair Practices Act. Subletting or subcontracting of any portion of the work in excess of one-half of one percent of the bidder's (prime contractor's) total bid as to which no subcontractor was designated in the original bid shall only be permitted in cases of public emergency or necessity, only after a finding reduced to writing as a public record of the DISTRICT awarding this contract setting forth the facts constituting the emergency or necessity.

Type of trade,
labor, or work
(Not %)

Name & License #
of Subcontractor, with
classification held
License Expiration Date,
and DIR registration Number

City of Office:
(or Address)
Telephone # and Email

Concrete	PMC Concrete Contractor Inc Classification C-8 License #817991 Exp 3/31/2021 DIR #1000007046	Costa Mesa, CA (949)645-4827 pmconcrete@sbcglobal.net
Stucco/Plaster	Metcalf, Inc Classification B, C-9, C35 License #673918 Exp 3/31/2021 DIR #1000002895	Pomona, CA (909) 595-2500 toddm@metcalfcompany.com
Floor Covering	Kevin J Renly Construction Classification B, C54, C15 License #541132 Exp 9/30/2022 DIR #1000002873	San Diego, CA (619)917-7039 kevinrenly@mac.com
Casework	Galleys Plus Custom Cabinets Inc Classification C-6 License #499901 Exp 7/31/2021 DIR #1000035484	Corona, CA (951) 278-4596 Andrew@galleysplus.com
Haul Buildings	Silver Creek LLC Classification N/A License # N/A DIR # N/A	Peris, CA (951)943-5393 tlopez@silver-creek.net
Haul Buildings	Cid's Enterprises Inc Classification N/A License # N/A DIR # N/A	Bloomington, CA (909) 877-3927 liliana@cidsenterprises.com
Set/Install/Dismantle Buildings Floor Covering	Pro-Fab Construction Inc Classification B, C47 License # 888796 Exp 12/31/2022 DIR #1000021190	Bloomington, CA (909)873-5996 liliana@cidsenterprises.com
New Buildings Install/Dismantle Buildings	Silver Creek Industries LLC Classification B, C27, C36, C10, C20 License #855259 Exp 11/30/2022 DIR #1000002864	Perris, CA (951) 943--5393 tlopez@silver-creek.net
Crane Buildings	Bragg Crane & Rigging Company Classification A, C51 License #505420 Exp 2/28/2021 DIR #1000002972	Long Beach, CA (562)243-4582 Leroy.Frye@braggcrane.com
Set/Install/Dismantle Buildings	DRV Modular Contractors Inc Classification B, C47 License #680131 Exp 7/31/2021 DIR #1000000387	La Mesa, CA (619)-670-9818 eddie@drvmodular.com

Note A: As part of the bid submittal, this form shall include the complete trade, company name, and City of Office, for all listed subs, at minimum. Bidder agrees that within eight (8) hours of the bid opening, Bidder shall provide the DISTRICT with the license number, license classification, expiration date of license, DIR Registration Number, complete address, telephone numbers, and email of each listed subcontractor if such information is not available at the time of the bid opening.

Dated: 12/9/2020

Address: 3091 Indian Ave

Elite Modular Leasing and Sales Inc

Perris, CA 92571

Name of Bidder / License # 1020113

By: 
(Signature of Bidder)

Telephone: 951-422-2500

Print Name: Jeremy Goldenetz

Email: jeremy@elitemodular.net



California Sub-Bid Request Ads



BAY CITIES PAVING & GRADING, INC.
1450 Civic Court | Concord, CA 94520
Office: (925) 687-6666 | Fax: (925) 687-2122

INVITATION TO BID

Bay Cities Paving & Grading, Inc. invites all certified DBE's to submit bids on the following project:

**SAN FRANCISCO BAY AREA RAPID TRANSIT DISTRICT
HAYWARD MAINTENANCE COMPLEX (PHASE 2) CIVIL GRADING**

CONTRACT No.: 01RQ-102

Revised Bid Date: December 21, 2020

Sub-trades/suppliers/truckers needed for following work (but not limited to): Differing Site Conditions; District-Caused Delays; Partnering; Dispute Resolution Board; RWP Training; Watchperson; Mobilization (Includes Equipment); Demolition; Cut; Fill; Clearing and Grubbing - Haul-off; Aggregate Subbase, Class 3 Below Wall Footing; Drain Rock Aggregate; 16" Steel Casing; 6" PVC Sewer Lateral C900 Class 200 (5 Ft to 7 Ft Deep Trench); 4" PVC Sewer Lateral C900 Class 200 (5 Ft to 7 Ft Deep Trench); 8" PVC Sewer Main C900 Class 200 (8 Ft to 10 Ft Deep Trench); Sanitary Sewer Manholes; 30" Reinforced Concrete Pipe; 24" Reinforced Concrete Pipe; 18" Reinforced Concrete Pipe; Storm Drain Manhole; Drainage Inlet - Type G2 caltrans - 36" x 36"; Bioretention Basin; 6" Perforated Plastic Pipe Underdrain; Hazardous Materials/ Waste Disposal; Structural Retaining Wall Rebar; Structural Retaining Wall Concrete; Structure Excavation; Structure Backfill; Sheet Pile Wall; 7 Ft CL Barrier Fence; 10 Ft Expanded Metal Fence with Razor Coil; Double 40 Ft Wide Cantilever Slide Gate; 15Ft Swing Gate; 20Ft Swing Gate; 8 Ft Chain Link Barrier with Barb Wire"; Golf Cart and Pedestrian Overcrossing Abutment Rebar; Golf Cart and Pedestrian Overcrossing Abutment Concrete; Overcrossing column and Drilled Concrete Shaft Rebar; Cart Overcrossing; Golf Cart and Pedestrian Overcrossing Abutment Excavation; Golf Cart and Pedestrian Overcrossing Abutment Ground Improvement; 72" Drilled Concrete Shaft Permanent Casing; 78" Drilled Concrete Shaft Permanent Casing; 72" Drilled Concrete Shaft; 78" Drilled Concrete Shaft; 12" Aggregate Base, Class 2; 4" Asphalt Concrete; Caltrans Type 84 Curb; 24" Reinforced Concrete Pipe; 18" Reinforced Concrete Pipe; Storm Drain Manhole; Drainage Inlet - Type G2 caltrans - 36" x 36"; Bioretention Basin; 6" Perforated Plastic Pipe Underdrain; Hazardous Materials/ Waste Disposal; Structural Retaining Wall Rebar; Structural Retaining Wall Concrete; Structure Excavation; Structure Backfill; Sheet Pile Wall; 7 Ft CL Barrier Fence; 10 Ft Expanded Metal Fence with Razor Coil; Double 40 Ft Wide Cantilever Slide Gate; 15Ft Swing Gate 20Ft Swing Gate; 8 Ft Chain Link Barrier with Barb Wire"; Golf Cart and Pedestrian Overcrossing Abutment Rebar; Golf Cart and Pedestrian Overcrossing Abutment Concrete; Overcrossing column and Drilled Concrete Shaft Rebar; Cart Overcrossing; Golf Cart and Pedestrian Overcrossing Abutment Excavation; Golf Cart and Pedestrian Overcrossing Abutment Ground Improvement; 72" Drilled Concrete Shaft Permanent Casing; 78" Drilled Concrete Shaft Permanent Casing; 72" Drilled Concrete Shaft; 78" Drilled Concrete Shaft; 12" Aggregate Base, Class 2; 4" Asphalt Concrete; Caltrans Type 84 Curb.

Plans and specifications for the Project are available for review at our office at 1450 Civic Court, Concord, CA 94520 or can be downloaded, please contact BCPG estimating department for assistance. 100% Performance, Payment Bonds by an admitted surety naming prime contractor as obligee, in the full amount of the subcontractors bid shall be required. Retention will be withheld if subcontractor fails to provide bonds. Bonding assistance is available, Bay Cities Paving & Grading, Inc., will pay bond premium up to 2%. Call Russ Olney or Robert Rosas at (925) 687-6666 for assistance with credit line, bonding, insurance, equipment, supplies and materials. Subcontractors will be required to enter into our standard contract. Items of work can be broken down to facilitate DBE and SBE participation. BCPG will make every effort to work cooperatively with all qualified firms seeking work on this project.

Please be advised, Contractors and Subcontractors must register with the D.I.R. (Department of Industrial Relations) in order to bid on public works projects. Registration with the D.I.R. costs \$300 and covers the fiscal year (July 1 to June 30th). To verify the status of your D.I.R. number, please visit: <http://www.dir.ca.gov/Public-Works/Contractors.html>.

Bay Cities Paving & Grading is signatory to the following Unions: Operators, Laborers, Teamsters, & Cement Masons.
Bay Cities Paving & Grading, Inc. is an Equal Opportunity Employer.

Mike Prlich and Sons, Inc
5103 Elton Street, Baldwin Park, CA 91706
Office: (626) 813-1700 • Fax: (626) 813-1770

**Project: Sun Valley Watershed
Upper Storm Drain System-Phase 1
Owner: Los Angeles County Public Works
Bid Date: December 15th, 2020 at 11:00am
Location: Tujunga Ave & Penrose St,
Los Angeles, CA 91605**

Mike Prlich and Sons, Inc is requesting Sub Contractors and Suppliers qualified under Community Business Enterprise (Minority/Women/Disadvantage/Disabled Veterans) owned firms to send quotes for the Sun Valley Watershed Upper Storm Drain System Phase 1 Project.

Qualified Sub Contractors Scope of Work:

Traffic Control, Shoring, Survey, Asphalt and/or Concrete Paving, Fencing, Saw cutting, Drilling, Trucking.

Requirements: Proof of CBE's qualifications, California Contractors License, Insurance, 100% Bonding of Subs prescribed work.

For questions or further information regarding the project, please contact Kevin Dowe at Bids@mikeprlichandsons.com

Elite Modular Leasing & Sales Inc.
We are requesting bid quotations from all DVBE Subcontractor/Supplier for the following:

Project: 2021 District-wide Unit Price Contract for the Purchase, Lease, Relocation, Dismantling and Removal of Division of the State Architect (DSA) Approved Portable Buildings, Project SSPU, #40-04/2020-21
BID DATE: December 11, 2020 at 8:00am
PLEASE EMAIL US YOUR BID PROPOSAL NO LATER THAN December 10, 2020 12 pm.
THANK YOU!

Elite Modular Leasing & Sales Inc.
3091 Indian Avenue, Perris, CA 92571
Estimator: Lou Menezes
Email: lou@elitemodular.net
Phone: (951) 422-2500

Silver Creek Industries

We are requesting bid quotations from all Subcontractors and Suppliers and DVBE Subcontractor/Supplier for the following:

**Merced River School District
Piggyback Bid for Modular Classroom Buildings and Associated Options**

Project No. 20046

BID DATE: December 11, 2020 at 11:30am

PLEASE EMAIL US YOUR BID PROPOSAL NO LATER THAN DECEMBER 9th, 2020.
THANK YOU!

Silver Creek Industries
2830 Barrett Avenue, Perris, CA 92571
Estimator: Shade Stoffel
Email: sstoffel@silver-creek.net
Phone: (951) 943-5393 • Fax: (951) 943-2211

BUILDGROUP

Build Group, Inc. is requesting subcontractor bids from all Certified / Qualified SBE subcontractors' and material suppliers for the following project:

SCVTA Restroom Renovation at Chaboya Bldg
Bid Date & Time: 12/18/20 at 2 PM

Scope of Work:

Renovation of existing men's and women's employee restrooms located in Building A at the Chaboya Division.

Email: estimatingpw@buildgc.com
Fax: 415-366-1883

Contact: William Reuvekamp at 925-818-6937 if you have any questions

Please email ALL bids and questions to estimatingpw@buildgc.com

SMALL

BUSINESS
EXCHANGE

REQUEST FOR SUBSTITUTION AT TIME OF BID FORM

TO: Schoolhaus Advisors, Inc.

DATE:

PROJECT: 2021 District-Wide Contract for the Purchase, Lease, Relocation, Dismantling, and Removal of Division of the State Architect Approved Portable Buildings

PROJECT #: SSPU, #40-04/2020-21

SPECIFICATION SECTION:

SPECIFIED ITEM:

ITEM PROPOSED FOR SUBSTITUTION:

Pursuant to Public Contract Code section 3400, bidder submits the following request to Substitute with the bid that is submitted. I understand that if the request to substitute is not "and/or equal" or is not accepted by District and I answer "no" I will not provide the specified item, then I will be held non-responsive and my bid will be rejected. With this understanding, I hereby request Substitution of the following articles, devices, equipment, products, materials, fixtures, patented processes, forms, methods, or types of construction:

	Specification Section	Specified Item	Requested Substituted Item	Contractor Agrees to Provide Specified Item if request to Substitute is Denied ¹ (circle one)		District Decision (circle one)	
1.				Yes	No	Grant	Deny
2.				Yes	No	Grant	Deny
3.				Yes	No	Grant	Deny
4.				Yes	No	Grant	Deny
5.				Yes	No	Grant	Deny
6.				Yes	No	Grant	Deny
7.				Yes	No	Grant	Deny

¹ Bidder must state whether bidder will provide the Specified Item in the event the Substitution request is evaluate and denied. If bidder states that bidder will not provide the Specified Item the denial of a request to Substitute shall result in the rejection of the bidder as non-responsive. However, if bidder states that bidder will provide the Specified Item in the event that bidder's request for Substitution is denied, bidder shall execute the Agreement and provide the Specified Item(s). If bidder refuses to execute the Agreement due to the District's decision to require the Specified Item(s) at no additional cost, bidder's Bid Bond shall be forfeited.

8.				Yes	No	Grant	Deny
9.				Yes	No	Grant	Deny
10.				Yes	No	Grant	Deny
11.				Yes	No	Grant	Deny
12.				Yes	No	Grant	Deny

This Request Form must be accompanied by evidence as to whether the proposed Substitution (1) is equal in quality, service, and ability to the Specified Item; (2) will entail no change in detail, construction, and scheduling of related work; (3) will be acceptable in consideration of the required design and artistic effect; (4) will provide no cost disadvantage to the District; (5) will require no excessive or more expensive maintenance, including adequacy and availability of replacement parts; (6) will require no change of the construction schedule or milestones for the Project; and, (7) Contractor agrees to pay for any DSA Fees or other Governmental Plan check costs associated with this Substitution Request. (See General Conditions Section 3.6)

The undersigned states that the following paragraphs are correct:

1. The proposed Substitution does not affect the dimensions shown on the Drawings.
2. The undersigned will pay for changes to the building design, including Architect, engineering, or other consultant design, detailing, DSA plan check or other governmental plan check costs, and construction costs caused by the requested substitution.
3. The proposed substitution will have no adverse effect on other trades, the Contract Time, or specified warranty requirements.
4. Maintenance and service parts will be available locally for the proposed substitution.
5. In order for the Architect to properly review the substitution request, within three (3) days following the opening of bids, the Contractor shall provide samples, test criteria, manufacturer information, and any other documents requested by Architect or Architect's engineers or consultants, including the submissions that would ordinarily be required under Article 3.7 for Shop Drawings along with a document which provides a side by side comparison of key characteristics and performance criteria (often known as a CSI side by side comparison chart).
6. If Substitution Request is accepted by the District, Contractor is still required to provide a Submittal for the substituted item pursuant to Article 3.7 and shall provide required Schedule information (including schedule fragnets, if applicable) for the substituted item as required under Article 8.3.2.1. The approval of the Architect, Engineer, or District of the substitution request does not mean that the Contractor is

relieved of Contractor's responsibilities for Submittals, Shop Drawings, and schedules under Article 3.7 and 8.3.2 if the Contractor is awarded the Project.

Name of Bidder: Elite Modular Leasing and Sales Inc.

By: Jeremy Goldenetz

District: _____

By: _____

**NONCOLLUSION AFFIDAVIT TO BE EXECUTED
BY BIDDER AND SUBMITTED WITH BID**

The undersigned declares:

I am the President [Title] of Elite Modular Leasing & Sales Inc [Name of Company], the party making the foregoing bid.

The bid is not made in the interest of, or on behalf of, any undisclosed person, partnership, company, association, organization, or corporation. The bid is genuine and not collusive or sham. The bidder has not directly or indirectly induced or solicited any other bidder to put in a false or sham bid. The bidder has not directly or indirectly colluded, conspired, connived, or agreed with any bidder or anyone else to put in a sham bid, or to refrain from bidding. The bidder has not in any manner, directly or indirectly, sought by agreement, communication, or conference with anyone to fix the bid price of the bidder or any other bidder, or to fix any overhead, profit, or cost element of the bid price, or of that of any other bidder. All statements contained in the bid are true. The bidder has not, directly or indirectly, submitted his or her bid price or any breakdown thereof, or the contents thereof, or divulged information or data relative thereto, to any corporation, partnership, company, association, organization, bid depository, or to any member or agent thereof, to effectuate a collusive or sham bid, and has not paid, and will not pay, any person or entity for such purpose.

Any person executing this declaration on behalf of a bidder that is a corporation, partnership, joint venture, limited liability company, limited liability partnership, or any other entity, hereby represents that he or she has full power to execute, and does execute, this declaration on behalf of the bidder.

I declare under penalty of perjury under the laws of the State of California that the foregoing is true and correct and that this declaration is executed on 12/9/2020 [Date], at Perris [City], CA [State].

Signed: _____

Typed Name: Jeremy Goldenetz

ACKNOWLEDGMENT

A notary public or other officer completing this certificate verifies only the identity of the individual who signed the document to which this certificate is attached, and not the truthfulness, accuracy, or validity of that document.

State of California
County of Riverside

On December 9, 2020 before me, Kimberley J. Vasquez, Notary
(insert name and title of the officer)

personally appeared Jeremy Goldenetz,
who proved to me on the basis of satisfactory evidence to be the person(s) whose name(s) is/are subscribed to the within instrument and acknowledged to me that he/she/they executed the same in his/her/their authorized capacity(ies), and that by his/her/their signature(s) on the instrument the person(s), or the entity upon behalf of which the person(s) acted, executed the instrument.

I certify under PENALTY OF PERJURY under the laws of the State of California that the foregoing paragraph is true and correct.

WITNESS my hand and official seal.

Signature K. Vasquez (Seal)

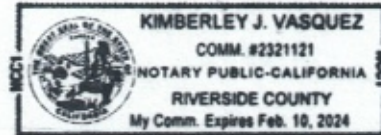

IRAN CONTRACTING ACT CERTIFICATION
(Public Contract Code Section 2200 st. seq.)

Bid No.: SSPU, #40-04/2020-21

Project: 2021 District-Wide Contract for the Purchase, Lease, Relocate, Dismantling, and Removal of Division of the State (DSA) Approved Portable Buildings

Bidding Contractor

("Bidder"): Elite Modular Leasing and Sales, Inc.

The undersigned, subject to penalty for perjury, hereby certifies to the District, subject to penalty for perjury pursuant to the laws of the State of California, that the following is true and correct:

- (i) The undersigned is a duly-authorized representative of the Bidder and, in that capacity, has executed this certification on behalf of the Bidder; and
- (ii) The appropriate box is checked immediately below (check only one box), and the statement relating to the Bidder's status in regard to the Iran Contracting Act of 2010 (Public Contract Code Section 2200 *et seq.*) following such box is true and correct.

The Bidder is not:

- (i) identified on the current list of persons and entities engaging in investment activities in Iran prepared by the California Department of General Services in accordance with subdivision (b) of Public Contract Code Section 2203; or
 - (ii) a financial institution that extends, for 45 days or more, credit in the amount of \$20,000,000 or more to any other person or entity identified on the current list of persons and entities engaging in investment activities in Iran prepared by the California Department of General Services in accordance with subdivision (b) of Public Contract Code Section 2203, if that person or entity uses or will use the credit to provide goods or services in the energy sector in Iran.
- The District has exempted the Bidder from the requirements of the Iran Contracting Act of 2010 after making a public finding that, absent the exemption, the District will be unable to obtain the goods and/or services to be provided pursuant to the Contract.
- The maximum total amount payable to the Bidder under each purchase order initiated under this Master Agreement in connection with the Project, as of the date of this certification, does not exceed one million dollars (\$1,000,000.00).

Notice: In accordance with Public Contract Code Section 2205, false certification of this form may result in civil penalties equal to the greater of \$250,000 or twice the contract amount, termination of the Contract and/or ineligibility to bid on contracts for three years.

Elite Modular Leasing and Sales, Inc
Contractor/Company

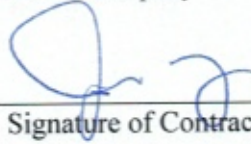
By: 
Signature of Contractor Representative

Jeremy Goldenetz
Print Name of Representative

President
Title

12/9/2020
Date

BID FORM-2 ATTACHMENT A - ADDENDUM #3
 2021 DISTRICT - WIDE CONTRACT FOR THE PURCHASE, RELOCATION, DISMANTLING AND REMOVAL OF DIVISION OF THE STATE ARCHITECT (DSA)
 APPROVED PORTABLE BUILDINGS, SSPU #40-04/2020-21
 INCLUDES 2021-22 4.9% CPI INCREASE

ITEM	DESCRIPTION	A REFURBISHED 24 X 40 Classroom	B REFURBISHED 36 X 40 Classroom	C REFURBISHED 48 X 40 Classroom	D REFURBISHED 12 X 40 MODULE	E REFURBISHED 24 X 60 Classroom	F REFURBISHED 12 X 60 MODULE
	APPROVED # OR PC# (LIST)	A# 66341	04-119120	04-117974	04-117974	04-116719	04-116719
1	BUILDING BASE BID PRICE PURCHASE	37,449	56,122	74,899	17,309	103,746	46,681
2A	INSTALLATION COSTS	5,140	7,658	7,868	2,602	9,231	5,140
2B	DISMANTLE COST	4,091	6,609	6,819	2,077	8,182	4,091
3A	INSTALLATION COSTS (PSA/PLA)	15,630	18,148	20,770	8,287	19,721	9,861
3B	DISMANTLE COSTS (PSA/PLA)	14,581	17,099	19,721	7,238	18,672	8,812
	ALTERNATIVES						
4	ONE YEAR LEASE ADVANCE ANNUAL PAYMENT	9,336	14,162	19,092	4,721	19,763	11,529
5	TWO YEAR LEASE ADVANCE ANNUAL PAYMENT	8,917	13,427	17,728	4,406	18,106	10,994
6	THREE YEAR LEASE ADVANCE ANNUAL PAYMENT	8,287	11,015	16,994	4,091	17,686	10,637
7	FOUR YEAR LEASE ADVANCE ANNUAL PAYMENT	8,077	10,280	16,260	3,881	16,763	10,280
8	FIVE YEAR LEASE ADVANCE ANNUAL PAYMENT	7,763	9,546	15,630	3,776	16,123	10,018
9	LEASE PURCHASE - 3 YEARS ADVANCE ANNUAL PAYMENT	18,620	30,421	35,351	10,280	41,436	20,560
10	LEASE PURCHASE - 5 YEARS ADVANCE ANNUAL PAYMENT	14,057	27,274	23,498	8,014	28,743	15,420
11	LEASE PURCHASE - 7 YEARS ADVANCE ANNUAL PAYMENT	9,126	13,847	19,092	5,350	26,015	13,008
	BUILDING ADDITIVE ALTERNATIVES						
	CONCRETE FOUNDATIONS:						
12	ABOVE GRADE	33,044	44,583	51,926	17,204	44,583	19,931
13	BELOW GRADE	36,086	48,779	55,387	19,407	48,779	15,420
14	BELOW GRADE W/18" CLEAR	40,072	51,401	62,625	22,239	51,401	26,015
15	50 LB + PARTITION LOAD STIFFENED FLOOR	3,042	4,091	5,140	1,521	12,064	4,804
16	70 LB FOUNDATION (WOOD)	2,623	3,672	4,721	1,311	3,818	1,490
17	100 LB STIFFENED FLOOR	8,182	12,420	14,896	4,091	15,567	8,287

BID FORM-2 ATTACHMENT A - ADDENDUM #3
2021 DISTRICT -WIDE CONTRACT FOR THE PURCHASE, RELOCATION, DISMANTLING AND REMOVAL OF DIVISION OF THE STATE ARCHITECT (DSA)
APPROVED PORTABLE BUILDINGS, SSPU #40-04/2020-21
INCLUDES 2021-22 4.9% CPI INCREASE

ITEM	DESCRIPTION	A REFURBISHED 24 X 40 Classroom	B REFURBISHED 36 X 40 Classroom	C REFURBISHED 48 X 40 Classroom	D REFURBISHED 12 X 40 MODULE	E REFURBISHED 24 X 60 Classroom	F REFURBISHED 12 X 60 MODULE
18	100 LB FOUNDATION (WOOD)	6,923	10,280	13,847	3,462	15,735	7,868
19	150 LB STIFFENED FLOOR	11,266	15,190	22,512	5,749	15,190	8,245
20	150 LB FOUNDATION (WOOD)	12,064	17,833	24,966	6,032	31,470	15,735
21	26 GA STEEL OVER 3/4" PLYWOOD	3,630	5,077	7,133	1,867	5,077	4,637

NOTE : FOR BID TO BE DEEMED VALID, PROOF OF DSA APPROVAL (PC OR STOCKPILE) FOR ALL CONFIGURATIONS LISTED MUST BE PRESENTED . AT THE TIME OF THE BID, ENTER THE A# OR PC# IN THE ROW NEAR THE TOP OF EACH PAGE OF THE BID FORM. PROVIDE APPROVED PLANS, OR OTHER BACK-UP WITHIN 24 HOURS OF THE BID OPENING. FAILURE TO PROVIDE THIS DATA WITHIN THIS TIME FRAME WILL CAUSE THE BID TO BE DECLARED NON-RESPONSIVE.

BID FORM-2 ATTACHMENT A - ADDENDUM #3
 2021 DISTRICT - WIDE CONTRACT FOR THE PURCHASE, RELOCATION, DISMANTLING AND REMOVAL OF DIVISION OF THE STATE ARCHITECT (DSA)
 APPROVED PORTABLE BUILDINGS, SSPU #40-04/2020-21
 INCLUDES 2021-22 4.9% CPI INCREASE

ITEM	DESCRIPTION	G	H	I	J	K	L
	APPROVED # OR PC# (LIST)						
22	BUILDING BASE BID PRICE PURCHASE	04-116126	04-116126	04-114126	04-100052	04-116720	04-117726
23A	INSTALLATION COSTS	71,857	23,603	75,948	69,234	70,283	67,500
23B	DISMANTLE COSTS	6,504	2,203	6,504	10,469	10,469	10,469
24A	INSTALLATION COSTS (PSA/PLA)	6,084	1,888	6,084	9,861	9,861	9,861
24B	DISMANTLE COSTS (PSA/PLA)	16,994	9,126	16,994	20,959	20,959	20,959
	ALTERNATIVES	15,945	8,077	15,945	19,910	19,910	19,910
25	ONE YEAR LEASE ADVANCE ANNUAL PAYMENT						
		30,316	9,966	31,365	29,372	30,421	31,470
26	TWO YEAR LEASE ADVANCE ANNUAL PAYMENT						
		28,218	9,336	28,848	27,274	28,323	29,372
27	THREE YEAR LEASE ADVANCE ANNUAL PAYMENT						
		26,120	8,707	26,750	25,176	26,225	27,274
28	FOUR YEAR LEASE ADVANCE ANNUAL PAYMENT						
		24,022	8,077	25,071	23,078	24,127	25,176
29	FIVE YEAR LEASE ADVANCE ANNUAL PAYMENT						
		21,505	7,238	22,554	20,980	22,029	23,078
30	LEASE PURCHASE - 3 YEARS ADVANCE ANNUAL PAYMENT						
		35,037	11,329	37,449	32,519	33,253	33,568
31	LEASE PURCHASE - 5 YEARS ADVANCE ANNUAL PAYMENT						
		25,701	9,126	29,897	26,750	26,750	28,323
32	LEASE PURCHASE - 7 YEARS ADVANCE ANNUAL PAYMENT						
		20,141	6,819	23,603	21,505	22,449	24,861
	BUILDING ADDITIVE ALTERNATIVES						
	CONCRETE FOUNDATIONS:						
33	ABOVE GRADE						
		33,044	17,623	17,623	23,498	23,498	23,498
34	BELOW GRADE						
		36,086	19,092	19,092	26,015	26,015	26,015
35	BELOW GRADE W/18" CLEAR						
		40,072	20,928	20,928	30,001	30,001	30,001
36	50 LB + PARTITION LOAD STIFFENED FLOOR						
		5,140	1,857	1,857	1,857	1,857	1,857
37	70 LB FOUNDATION (WOOD)						
		6,504	3,252	3,252	3,252	3,252	3,252
38	100 LB STIFFENED FLOOR						
		10,280	6,189	6,189	4,616	4,616	4,616

BID FORM-2 ATTACHMENT A - ADDENDUM #3

2021 DISTRICT -WIDE CONTRACT FOR THE PURCHASE, RELOCATION, DISMANTLING AND REMOVAL OF DIVISION OF THE STATE ARCHITECT (DSA)

APPROVED PORTABLE BUILDINGS, SSPU #40-04/2020-21

INCLUDES 2021-22 4.9% CPI INCREASE

ITEM	DESCRIPTION	G	H	I	J	K	L
39	100 LB FOUNDATION (WOOD)	REFURBISHED 30 X 32 CLASSROOM	REFURBISHED 10 X 32 MODULE	REFURBISHED 10 X 32 RR MODULE	REFURBISHED 12 X 40 TOILET A B/G	REFURBISHED 12 X 40 TOILET B B/S/G	REFURBISHED 12 X 40 TOILET C B/G/S/S
40	150 LB STIFFENED FLOOR	11,266	5,749	5,749	5,749	5,749	5,749
41	150 LB FOUNDATION (WOOD)	23,917	7,868	7,868	11,959	11,959	11,959
42	26 GA STEEL OVER 3/4" PLYWOOD	3,630	1,780	1,780	2,528	2,528	2,528

NOTE : FOR BID TO BE DEEMED VALID, PROOF OF DSA APPROVAL (PC OR STOCKPILE) FOR ALL CONFIGURATIONS LISTED MUST BE PRESENTED. AT THE TIME OF THE BID, ENTER THE A# OR PC# IN THE ROW NEAR THE TOP OF EACH PAGE OF THE BID FORM. PROVIDE APPROVED PLANS, OR OTHER BACK-UP WITHIN 24 HOURS OF THE BID OPENING. FAILURE TO PROVIDE THIS DATA WITHIN THIS TIME FRAME WILL CAUSE THE BID TO BE DECLARED NON-RESPONSIVE.

BID FORM-2 ATTACHMENT A - ADDENDUM #3
 2021 DISTRICT - WIDE CONTRACT FOR THE PURCHASE, RELOCATION, DISMANTLING AND REMOVAL OF DIVISION OF THE STATE ARCHITECT (DSA)
 APPROVED PORTABLE BUILDINGS, SSPU #40-04/2020-21
 INCLUDES 2021-22 4.9% CPI INCREASE

ITEM	DESCRIPTION	M	N	O	P	Q	R
	APPROVED # OR PC# (LIST)						
43	BUILDING BASE BID PRICE PURCHASE	NEW 24 X 40 Classroom 04-117725	NEW 36 X 40 Classroom 04-117725	NEW 48 X 40 Classroom 04-117725	NEW 12 X 40 MODULE 04-117725	NEW 24 X 60 Classroom 04-116719	NEW 12 X 60 MODULE 04-116719
44A	INSTALLATION COSTS	68,710	103,956	123,258	38,498	128,607	64,304
44B	DISMANTLE COSTS	5,140	7,658	10,280	3,881	9,231	5,140
45A	INSTALLATION COSTS (PSA/PLA)	4,091	6,609	9,231	2,077	8,182	4,091
45B	DISMANTLE COSTS (PSA/PLA)	15,630	18,148	20,770	8,287	19,721	9,861
	ALTERNATIVES	14,581	17,099	19,721	7,238	18,672	8,812
46	ONE YEAR LEASE ADVANCE ANNUAL PAYMENT						
		34,617	50,352	65,038	14,686	60,842	23,078
47	TWO YEAR LEASE ADVANCE ANNUAL PAYMENT						
		32,519	44,058	56,646	12,588	54,548	18,882
48	THREE YEAR LEASE ADVANCE ANNUAL PAYMENT						
		29,372	39,862	51,401	11,434	50,352	16,784
49	FOUR YEAR LEASE ADVANCE ANNUAL PAYMENT						
		27,274	36,715	48,254	10,700	44,478	15,106
50	FIVE YEAR LEASE ADVANCE ANNUAL PAYMENT						
		23,917	33,568	41,960	9,441	39,862	12,588
51	LEASE PURCHASE - 3 YEARS ADVANCE ANNUAL PAYMENT						
		36,610	54,915	65,038	18,358	67,556	33,778
52	LEASE PURCHASE - 5 YEARS ADVANCE ANNUAL PAYMENT						
		30,946	45,632	57,590	16,679	59,269	29,792
53	LEASE PURCHASE - 7 YEARS ADVANCE ANNUAL PAYMENT						
		22,239	33,463	41,436	13,217	43,534	21,714
	BUILDING ADDITIVE ALTERNATIVES						
	CONCRETE FOUNDATIONS:						
54	ABOVE GRADE						
		33,044	44,583	51,926	17,204	44,583	19,931
55	BELOW GRADE						
		36,086	48,779	55,387	19,407	48,779	23,603
56	BELOW GRADE W/18" CLEAR						
		40,072	51,401	62,625	22,239	51,401	26,015
57	50 LB + PARTITION LOAD STIFFENED FLOOR						
		1,406	2,046	2,602	808	2,046	976
58	70 LB FOUNDATION (WOOD)						
		3,357	4,301	6,714	1,993	9,100	4,825
59	100 LB STIFFENED FLOOR						
		2,518	3,986	7,133	1,469	3,986	2,811

BID FORM-2 ATTACHMENT A - ADDENDUM #3
 2021 DISTRICT -WIDE CONTRACT FOR THE PURCHASE, RELOCATION, DISMANTLING AND REMOVAL OF DIVISION OF THE STATE ARCHITECT (DSA)
 APPROVED PORTABLE BUILDINGS, SSPU #40-04/2020-21
 INCLUDES 2021-22 4.9% CPI INCREASE

ITEM	DESCRIPTION	M NEW 24 X 40 Classroom	N NEW 36 X 40 Classroom	O NEW 48 X 40 Classroom	P NEW 12 X 40 MODULE	Q NEW 24 X 60 Classroom	R NEW 12 X 60 MODULE
60	100 LB FOUNDATION (WOOD)	10,910	13,637	17,204	6,504	15,735	7,868
61	150 LB STIFFENED FLOOR	7,595	12,001	15,148	3,567	12,001	5,979
62	150 LB FOUNDATION (WOOD)	23,917	31,470	40,701	11,959	31,470	15,735
63	SLAB ON GRADE FLOOR	46,995	67,849	93,256	23,498	67,849	33,568
64	LIGHT WEIGHT CONCRETE FLOOR	25,176	51,842	69,654	18,358	51,842	29,897
65	40 LB SNOW LOAD	28,848	41,540	54,968	15,315	41,540	20,928
66	60 LB SNOW LOAD	40,177	62,122	74,479	20,812	62,122	30,148
67	100 LB SNOW LOAD	51,611	78,654	103,222	26,173	78,654	39,338
68	10' CEILINGS	14,057	24,337	26,120	8,203	24,337	12,693
69	12' CEILINGS	40,491	57,275	80,605	20,676	57,275	28,638
70	VARIABLE PITCH ROOF	47,100	69,339	92,312	23,550	69,339	34,722
71	26 GA STEEL OVER 3/4" PLYWOOD	3,630	5,077	7,133	1,867	5,077	3,042

NOTE: FOR BID TO BE DEEMED VALID, PROOF OF DSA APPROVAL (PC OR STOCKPILE) FOR ALL CONFIGURATIONS LISTED MUST BE PRESENTED. AT THE TIME OF THE BID, ENTER THE
 A# OR PC# IN THE ROW NEAR THE TOP OF EACH PAGE OF THE BID FORM. PROVIDE APPROVED PLANS, OR OTHER BACK-UP WITHIN 24 HOURS OF THE BID OPENING. FAILURE TO
 PROVIDE THIS DATA WITHIN THIS TIME FRAME WILL CAUSE THE BID TO BE DECLARED NON-RESPONSIVE.

BID FORM-2 ATTACHMENT A - ADDENDUM #3
 2021 DISTRICT - WIDE CONTRACT FOR THE PURCHASE, RELOCATION, DISMANTLING AND REMOVAL OF DIVISION OF THE STATE ARCHITECT (DSA)
 APPROVED PORTABLE BUILDINGS, SSPU #40-04/2020-21
 INCLUDES 2021-22 4.9% CPI INCREASE

ITEM	DESCRIPTION	S NEW 30 X 32 CLASSROOM	T NEW 10 X 32 MODULE	U NEW 10 X 32 RR MODULE	V NEW 12 X 40 TOILET A B/G	W NEW 12 X 40 TOILET B B/S/G	X NEW 12 X 40 TOILET C B/G/S/S
	APPROVED # OR PC# (LIST)	04-116126	04-116126	04-116126	04-117726	04-116720	04-117726
72	BUILDING BASE BID PRICE PURCHASE	101,543	33,568	96,613	81,822	82,347	79,000
73A	INSTALLATION COSTS	5,140	2,203	6,504	6,504	6,504	6,504
73B	DISMANTLE COSTS	6,084	1,888	6,084	8,812	8,812	8,812
74A	INSTALLATION COSTS (PSA/PLA)	16,994	9,126	16,994	20,959	20,959	20,959
74B	DISMANTLE COSTS (PSA/PLA)	15,945	8,077	15,945	19,910	19,910	19,910
	ALTERNATIVES						
75	ONE YEAR LEASE ADVANCE ANNUAL PAYMENT	46,156	15,735	43,534	37,764	38,813	39,862
76	TWO YEAR LEASE ADVANCE ANNUAL PAYMENT	43,009	14,791	40,387	35,666	36,715	37,764
77	THREE YEAR LEASE ADVANCE ANNUAL PAYMENT	39,233	13,217	37,240	33,568	34,617	35,666
78	FOUR YEAR LEASE ADVANCE ANNUAL PAYMENT	33,778	11,224	31,365	31,470	32,519	33,568
79	FIVE YEAR LEASE ADVANCE ANNUAL PAYMENT	31,260	10,280	29,267	29,372	30,421	31,470
80	LEASE PURCHASE - 3 YEARS ADVANCE ANNUAL PAYMENT	45,632	18,043	43,534	39,338	40,596	41,855
81	LEASE PURCHASE - 5 YEARS ADVANCE ANNUAL PAYMENT	39,862	15,525	38,708	35,142	36,400	37,659
82	LEASE PURCHASE - 7 YEARS ADVANCE ANNUAL PAYMENT	37,659	11,434	35,561	31,365	31,995	33,253
	BUILDING ADDITIVE ALTERNATIVES						
	CONCRETE FOUNDATIONS:						
83	ABOVE GRADE	33,044	17,623	17,623	23,498	23,498	23,498
84	BELOW GRADE	36,086	19,092	19,092	26,015	26,015	26,015
85	BELOW GRADE W/18" CLEAR	40,072	20,928	20,928	30,001	30,001	30,001
86	50 LB + PARTITION LOAD STIFFENED FLOOR	5,140	1,731	1,731	1,857	1,857	1,857
87	70 LB FOUNDATION (WOOD)	6,504	2,832	2,832	3,252	3,252	3,252
88	100 LB STIFFENED FLOOR	2,518	1,532	1,532	2,518	2,518	2,518

BID FORM-2 ATTACHMENT A - ADDENDUM #3
 2021 DISTRICT -WIDE CONTRACT FOR THE PURCHASE, RELOCATION, DISMANTLING AND REMOVAL OF DIVISION OF THE STATE ARCHITECT (DSA)
 APPROVED PORTABLE BUILDINGS, SSPU #40-04/2020-21
 INCLUDES 2021-22 4.9% CPI INCREASE

ITEM	DESCRIPTION	S NEW 30 X 32 CLASSROOM	T NEW 10 X 32 MODULE	U NEW 10 X 32 RR MODULE	V NEW 12 X 40 TOILET A B/G	W NEW 12 X 40 TOILET B B/S/G	X NEW 12 X 40 TOILET C B/G/S/S
89	100 LB FOUNDATION (WOOD)	13,008	4,301	4,301	6,504	6,504	6,504
90	150 LB STIFFENED FLOOR	7,595	3,672	3,672	3,986	3,986	3,986
91	150 LB FOUNDATION (WOOD)	23,917	7,868	7,868	11,959	11,959	11,959
92	SLAB ON GRADE FLOOR	46,995	25,805	25,805	28,533	28,533	28,533
93	LIGHT WEIGHT CONCRETE FLOOR	25,176	12,588	12,588	12,588	12,588	12,588
94	40 LB SNOW LOAD	39,338	17,938	17,938	20,833	20,833	20,833
95	60 LB SNOW LOAD	29,687	22,029	22,029	26,435	26,435	26,435
96	100 LB SNOW LOAD	51,611	28,848	28,848	31,365	31,365	31,365
97	10' CEILINGS	14,057	8,182	8,182	10,280	10,280	10,280
98	12' CEILINGS	40,491	22,239	22,239	28,533	28,533	28,533
99	VARIABLE PITCH ROOF	47,100	29,792	29,792	34,197	34,197	34,197
100	26 GA STEEL OVER 3/4" PLYWOOD	3,630	2,077	2,077	2,528	2,528	2,528

NOTE: FOR BID TO BE DEEMED VALID, PROOF OF DSA APPROVAL (PC OR STOCKPILE) FOR ALL CONFIGURATIONS LISTED MUST BE PRESENTED. AT THE TIME OF THE BID, ENTER THE A# OR PC# IN THE ROW NEAR THE TOP OF EACH PAGE OF THE BID FORM. PROVIDE APPROVED PLANS, OR OTHER BACK-UP WITHIN 24 HOURS OF THE BID OPENING. FAILURE TO PROVIDE THIS DATA WITHIN THIS TIME FRAME WILL CAUSE THE BID TO BE DECLARED NON-RESPONSIVE.

<p>NOTE: LINE ITEMS 101-129 WERE OMITTED VIA ADDENDUM #3</p>
<p>NOTE: LINE ITEMS 130-160 WERE OMITTED VIA ADDENDUM #1</p>

BID FORM-2: ATTACHMENT B - ADDENDUM #1

2021 DISTRICT-WIDE CONTRACT FOR THE PURCHASE, RELOCATION, DISMANTLING AND REMOVAL OF DIVISION OF THE STATE ARCHITECT (DSA) APPROVED PORTABLE BUILDINGS, SSPU #40-04/2020-21

2022 Contract Extension Includes a 4.9% Price Increase (per 1-19-22 SSPU ext. letter)			
ITEM #	DESCRIPTION	UNIT	PRICE
FLOORING			
161	STANDARD CARPET 26 OZ NYLON	SQUARE FOOT	4.75
162	NON STANDARD CARPET - MOHAWK GROUP LEES FACULTY 4	SQUARE FOOT	10.00
163	NON STANDARD CARPET - TANDUS (OR EQUAL)	SQUARE FOOT	16.00
164	MODULAR CARPET TILES 24" X 24" STANDARD 22 OZ	SQUARE FOOT	13.00
165	MODULAR CARPET TILES 24" X 24" UPGRADED 26 OZ	SQUARE FOOT	14.00
166	GEO TILES TRIAD MAT SERIES - COLLINS & AIKMAN / TANDUS	SQUARE FOOT	25.00
167	ABRASIVE ACTION WALK OFF MATT - TANDUS	SQUARE FOOT	21.00
168	VCT	SQUARE FOOT	7.50
169	RUBBER BASE 4" BURKE OR EQUAL	LINEAR FOOT	6.50
170	RUBBER BASE 6" BURKE OR EQUAL	LINEAR FOOT	7.50
171	SUBSTRATE	SQUARE FOOT	26.00
172	CERAMIC TILE COVERED BASE	LINEAR FOOT	26.00
173	QUARRY TILE 6" X 6"	SQUARE FOOT	35.00
174	SHEET VINYL WITH SELF COVE BASE	SQUARE FOOT	16.00
175	VINYL UPGRADE TO FORBO MARMOLEUM	SQUARE FOOT	25.00
176	EPOXY FLOORING (AND/OR WALL COATING)	SQUARE FOOT	34.00
177	R-19 INSULATION	SQUARE FOOT	2.25
178	R-30 INSULATION	SQUARE FOOT	3.75
179	KITCHEN SHOWER AREA ALTRA MARINE SAFETY FLOOR	SQUARE FOOT	23.00
180	ACCESS PANEL - THROUGH FLOOR 24" X 24"	EACH	1,049.00
181	WELDED SEAMS	LINEAR FOOT	18.00
182	CARPET SEAMING	LINEAR FOOT	10.00
183	CARPET BAR	LINEAR FOOT	8.50
184	REMOVE EXISTING VCT	SQUARE FOOT	3.25
185	REMOVE EXISTING GLUE DOWN CARPET	SQUARE YARD	4.75
WALLS			
186	INTERIOR NON-RATED 2 X 4 WALL, HIGH 16" OC FLOOR TO RAFTERS	LINEAR FOOT	115.00
187	2 X 6 EXTERIOR WALL WITH R19 INSULATION	LINEAR FOOT	126.00
188	2 X 8 EXTERIOR WALL WITH R30 INSULATION	LINEAR FOOT	178.00
189	INTERIOR 1 HOUR FIRE RATED WALL	LINEAR FOOT	220.00
190	INTERIOR 2 HOUR FIRE RATED WALL	LINEAR FOOT	357.00
191	EXTERIOR 1 HOUR RATED FIRE RATED WALL	LINEAR FOOT	184.00
192	EXTERIOR 2 HOUR RATED FIRE RATED WALL	LINEAR FOOT	236.00
193	TAPE AND TEXTURE AND PAINT IN LIEU OF VINYL COVERED TACKBOARD	SQUARE FOOT	8.00
194	STAINLESS STEEL WALL COVERING	SQUARE FOOT	30.00
195	FIBER GLASS WALL PANELS (FRP) IN LIEU OF VINYL COVERED TACKBOARD	SQUARE FOOT	19.00
196	WALL VINYL UPGRADE 'A'	SQUARE FOOT	3.00
197	WALL VINYL UPGRADE 'B'	SQUARE FOOT	4.25
198	MAGNETIC PANEL WALL COVER - PPA-412 4 X 12	SQUARE FOOT	18.00
199	OPERABLE WALL	LINEAR FOOT	1,023.00
200	CERAMIC TILE WALL, THIN SET	SQUARE FOOT	26.00
201	24 GAUGE WHITE PORCELAIN ENAMEL STEEL MARKER BOARD (8' X 4')	EACH	446.00
202	SOUNDBOARD ADD TO INTERIOR WALL	LINEAR FOOT	73.00
203	WALL BLOCKING (WOOD)	LINEAR FOOT	23.00
204	PAINT INTERIOR WALL (STANDARD PAINT)	SQUARE FOOT	4.25
	EXTERIOR TRIM	LINEAR FOOT	4.50
206	EXTERIOR WOOD SIDING	SQUARE FOOT	10.50
207	TEMPERED GLASS WALL	SQUARE FOOT	84.00
208	EXTERIOR PANEL - WUI CODE APPROVED PRODUCT	SQUARE FOOT	16.00
209	EXTERIOR CEMENTITIOUS SIDING	SQUARE FOOT	16.00
210	EXTERIOR CORRUGATED METAL	SQUARE FOOT	23.00
ROOF / CEILING			
211	HARD CEILINGS	SQUARE FOOT	31.00
212	ACOUSTICAL LAY-IN 2' X 2' X 5/8"	SQUARE FOOT	21.00

BID FORM-2: ATTACHMENT B - ADDENDUM #1

2021 DISTRICT-WIDE CONTRACT FOR THE PURCHASE, RELOCATION, DISMANTLING AND REMOVAL OF DIVISION OF THE STATE ARCHITECT (DSA) APPROVED PORTABLE BUILDINGS, SSPU #40-04/2020-21

213	CEILING GRID 2' X 4' WITH STANDARD EDGE CEILING PANELS	SQUARE FOOT	23.00
214	1 HOUR FIRE RATED CEILINGS	SQUARE FOOT	8.00
215	EXTEND REAR OVERHANG TO 5' (2'-6" STANDARD)	MODULE	1,154.00
216	BUILT UP ROOF SYSTEM 1-PLY	SQUARE FOOT	15.00
217	FACTORY STANDARD TPO ROOF SYSTEM .45 MIL	SQUARE FOOT	12.00
218	WELDED SEAMS ON SITE	SQUARE FOOT	10.50
219	.45 MIL WHITE EPDM ROOF SYSTEM	SQUARE FOOT	9.50
220	.60 MIL WHITE EPDM ROOF SYSTEM	SQUARE FOOT	10.00
221	UPGRADE PREFINISHED STANDING SEAM ROOF (COLORED)	SQUARE FOOT	13.00
222	ADD FOR 20 YEAR ROOF WARRANTY	PER MODULE	3,147.00
223	18" PARAPET	LINEAR FOOT	208.00
224	24" PARAPET	LINEAR FOOT	241.00
225	36" PARAPET	LINEAR FOOT	262.00
226	42" PARAPET	LINEAR FOOT	304.00
227	30" FASCIA METAL	LINEAR FOOT	325.00
228	30" FASCIA STUCCO	LINEAR FOOT	325.00
229	10" TUBULAR SKYLIGHT	EACH	3,357.00
230	14" TUBULAR SKYLIGHT	EACH	3,567.00
231	21" TUBULAR SKYLIGHT	EACH	4,720.00
232	TUBULAR SKYLIGHT DIMMERS	EACH	472.00
233	ROOF HATCH	EACH	3,671.00
234	ROOF ACCESS LADDER, INTERIOR, FIXED TO WALL	LINEAR FOOT	944.00
235	ROOF ACCESS LADDER, EXTERIOR, FIXED TO WALL	LINEAR FOOT	1,259.00
236	SEAMLESS GUTTERS	LINEAR FOOT	32.50
237	GUTTERS 24 GAUGE METAL	LINEAR FOOT	19.00
238	DOWNSPOUTS (STANDARD)	LINEAR FOOT	16.00
239	DOWNSPOUTS - UPGRADE TO 3" DIAMETER STEEL PIPE	LINEAR FOOT	37.00
240	ROOF DRAINS	EACH	1,783.00
241	SCUPPERS AND DOWNSPOUTS	EACH	2,518.00
242	MECHANICAL SCREENS (36" MAX HIGH)	LINEAR FOOT	68.00
	DOORS		
243	EXTERIOR DOOR PACKAGE - STEEL 3'	EACH	2,413.00
244	EXTERIOR DOOR PACKAGE - STEEL 4'	EACH	3,252.00
245	EXTERIOR DOOR PACKAGE - STEEL 6'	EACH	4,720.00
246	UPGRADE TO WELDED DOOR FRAME - 3'	EACH	525.00
247	UPGRADE TO WELDED DOOR FRAME - 4'	EACH	1,836.00
248	UPGRADE TO WELDED DOOR FRAME - 6'	EACH	2,046.00
249	7" WIDE VIEW KIT	EACH	367.00
250	24" WIDE VIEW KIT	EACH	944.00
251	HOLLOW METAL TRANSOM	SQUARE FOOT	734.00
252	STOREFRONT GLASS DOOR - 3'	EACH	8,812.00
253	STOREFRONT GLASS DOOR - 6'	EACH	16,994.00
254	EXTERIOR 1 HOUR FIRE RATED 3' DOOR	EACH	2,518.00
255	INTERIOR 1 HOUR FIRE RATED 3' DOOR	EACH	1,888.00
256	EXTERIOR 2 HOUR FIRE RATED 3' DOOR	EACH	3,147.00
257	INTERIOR 2 HOUR FIRE RATED 3' DOOR	EACH	2,885.00
258	INTERIOR DOOR PACKAGE - WOOD - 3'	EACH	1,364.00
259	INTERIOR DOOR PACKAGE - WOOD - 4'	EACH	1,678.00
260	INTERIOR DOOR PACKAGE - WOOD - 6'	EACH	2,727.00
261	POCKET DOOR - 3'	EACH	1,783.00
262	DOOR LOUVER	SQUARE FOOT	189.00
263	ROLLUP OVERHEAD DOOR	SQUARE FOOT	262.00
264	ROLLUP OVERHEAD DOOR MOTORIZED	SQUARE FOOT	309.00
265	PANIC HARDWARE IN LIEU OF STANDARD LOCKSET	EACH	1,783.00
266	SCHLAGE VANDAL GUARD OR EQUAL IN LIEU OF STANDARD	EACH	1,154.00
267	HARDWARE UPGRADE "A"	EACH	1,574.00
268	HARDWARE UPGRADE "B"	EACH	2,623.00

BID FORM-2: ATTACHMENT B - ADDENDUM #1

2021 DISTRICT-WIDE CONTRACT FOR THE PURCHASE, RELOCATION, DISMANTLING AND REMOVAL OF DIVISION OF THE STATE ARCHITECT (DSA) APPROVED PORTABLE BUILDINGS, SSPU #40-04/2020-21

269	HARDWARE UPGRADE "C"	EACH	3,147.00
270	DOOR CLOSER UPGRADE	EACH	420.00
271	KICK PLATE	EACH	73.00
	WINDOWS		
272	4020 XO / DG SLIDING ALUMINUM WINDOW 46%	EACH	2,413.00
273	4040 XO / DG SLIDING ALUMINUM WINDOW 46%	EACH	2,622.00
274	6020 XO / DG SLIDING ALUMINUM WINDOW 46%	EACH	2,937.00
275	6040 XO / DG SLIDING ALUMINUM WINDOW 46%	EACH	3,042.00
276	8020 XO / DG SLIDING ALUMINUM WINDOW 46%	EACH	3,147.00
277	8040 XO / DG SLIDING ALUMINUM WINDOW 46%	EACH	3,357.00
278	4020 HOLLOW METAL FRAME UPGRADE	EACH	1,993.00
279	4040 HOLLOW METAL FRAME UPGRADE	EACH	2,308.00
280	6020 HOLLOW METAL FRAME UPGRADE	EACH	2,518.00
281	6040 HOLLOW METAL FRAME UPGRADE	EACH	2,937.00
282	8020 HOLLOW METAL FRAME UPGRADE	EACH	3,357.00
283	8040 HOLLOW METAL FRAME UPGRADE	EACH	3,776.00
284	4040 FIXED INTERIOR WINDOW	EACH	1,259.00
285	UPGRADE TO LOW E GLAZING	SQUARE FOOT	73.00
286	UPGRADE TO LEXAN GLASS	SQUARE FOOT	73.00
287	SECURITY SCREENS 8' X 4'	EACH	787.00
288	WINDOW BLINDS	EACH	472.00
	ELECTRICAL		
289	100 AMP SINGLE PHASE PANEL	EACH	1,154.00
290	125 AMP SINGLE PHASE PANEL	EACH	1,364.00
291	150 AMP SINGLE PHASE PANEL	EACH	1,469.00
292	200 AMP SINGLE PHASE PANEL	EACH	2,203.00
293	225 AMP SINGLE PHASE PANEL	EACH	2,832.00
294	250 AMP SINGLE PHASE PANEL	EACH	3,042.00
295	100 AMP THREE PHASE PANEL	EACH	1,154.00
296	125 AMP THREE PHASE PANEL	EACH	1,259.00
297	150 AMP THREE PHASE PANEL	EACH	1,469.00
298	200 AMP THREE PHASE PANEL	EACH	1,678.00
299	225 AMP THREE PHASE PANEL	EACH	1,783.00
300	250 AMP THREE PHASE PANEL	EACH	2,203.00
301	6 X 6 X 6 EXTERIOR SIGNAL BOX W/ 3/4" CONDUIT TO ATTIC	EACH	210.00
302	EXTERIOR WALL PACK	EACH	472.00
303	110V DUPLEX WALL RECEPTACLE WITH COVER PLATE	EACH	210.00
304	110V DUPLEX WALL RECEPTACLE WITH COVER PLATE - DEDICATED	EACH	325.00
305	110V DUPLEX WALL GFCI RECEPTACLE WITH COVER PLATE	EACH	226.00
306	110V DUPLEX EXTERIOR WALL GFCI RECEPTACLE W/ IN-USE COVER	EACH	288.00
307	110V DUPLEX SURGE SUPPRESSED COMPUTER RECEPTACLE W/ COVER PLATE	EACH	367.00
308	110V DUPLEX FLOOR RECEPTACLE W/ DATA BOX & PLASTIC COVER PLATE	EACH	1,731.00
309	110V DUPLEX FLOOR RECEPTACLE W/ DATA BOX & BRASS COVER PLATE	EACH	2,046.00
310	110V QUADPLEX FLOOR RECEPTACLE W/ DATA BOX & PLASTIC COVER PLATE	EACH	2,360.00
311	110V QUADPLEX FLOOR RECEPTACLE W/ DATA BOX & BRASS COVER PLATE	EACH	2,885.00
312	220V DUPLEX WALL RECEPTACLE WITH COVER PLATE	EACH	420.00
313	20 AMP CIRCUIT - WALL	EACH	304.00
314	30 AMP CIRCUIT - WALL	EACH	357.00
315	40 AMP CIRCUIT - WALL	EACH	378.00
316	50 AMP CIRCUIT - WALL	EACH	388.00
317	60 AMP CIRCUIT - WALL	EACH	399.00
318	DEDICATED QUADPLEX WALL RECEPTACLE	EACH	346.00
319	WIREMOLD	LINEAR FOOT	105.00
320	DATA WALL BOX WITH BLANK COVER PLATE (4SD J-BOX)	EACH	115.00
321	INTERIOR LIGHT SWITCH	EACH	115.00
322	INTERIOR LIGHT SWITCH - THREE WAY	EACH	189.00
323	INTERIOR 2 X 4 FLUORESCENT FIXTURE W/ A+ LOW HARMONIC BALLAST	EACH	283.00

BID FORM-2: ATTACHMENT B - ADDENDUM #1

2021 DISTRICT-WIDE CONTRACT FOR THE PURCHASE, RELOCATION, DISMANTLING AND REMOVAL OF DIVISION OF THE STATE ARCHITECT (DSA) APPROVED PORTABLE BUILDINGS, SSPU #40-04/2020-21

324	INTERIOR 2 X 4 FLUORESCENT FIXTURE W/ BATTERY BACKUP	EACH	608.00
325	INTERIOR 2 X 4 FIXTURE LED	EACH	472.00
326	INTERIOR 2 X 2 FIXTURE LED	EACH	467.00
327	ADD PARABOLIC LENSES	EACH	393.00
328	EMERGENCY LIGHT W/BATTERY BACK UP - INTERIOR WALL MOUNT	EACH	346.00
329	EXIT LIGHT W/BATTERY BACK UP - INTERIOR WALL MOUNT	EACH	493.00
330	EXTERIOR FIXTURE WITH INTEGRAL PHOTO CELL	EACH	545.00
331	SMOKE / HEAT DETECTOR (4SD J-BOX)	EACH	178.00
332	CEILING MOUNTED MOTION SENSOR (4SD J-BOX)	EACH	283.00
333	WALL MOUNTED MOTION SENSOR (4SD J-BOX)	EACH	252.00
334	CONDUIT 3/4"	LINEAR FOOT	2.00
335	CONDUIT 1"	LINEAR FOOT	2.75
336	CONDUIT 1-1/2"	LINEAR FOOT	3.00
337	CONDUIT 2"	LINEAR FOOT	3.25
	HEAT AND COOLING		
338	UPGRADE 4T WALL MT HEAT PUMP TO 5T WALL MT HEAT PUMP	EACH	2,518.00
339	UPGRADE 4T WALL MT HEAT PUMP TP 3.5T ROOF MT HEAT PUMP	EACH	19,931.00
340	UPGRADE 4T WALL MT HEAT PUMP TO 4T ROOF MT HEAT PUMP	EACH	20,980.00
341	UPGRADE 4T WALL MT HEAT PUMP TO 5T ROOF MT HEAT PUMP	EACH	23,078.00
342	UPGRADE 4T WALL MT HEAT PUMP TO 4T INTERIOR HEAT PUMP	EACH	11,539.00
343	UPGRADE 4T WALL MT HEAT PUMP TO 5T INTERIOR HEAT PUMP	EACH	13,637.00
344	AIR BALANCING	PER HVAC UNIT	1,154.00
345	AIR BALANCING (CERTIFIED)	PER HVAC UNIT	1,364.00
346	CO2 SENSOR	EACH	944.00
347	BARD ECONOMIZER UPGRADE	EACH	3,986.00
348	PROGRAMMABLE THERMOSTAT	EACH	304.00
349	UPGRADE WALL OR ROOF MOUNTED HVAC TO GAS (NIC: GAS LINES OR CONNECTIONS)	EACH	525.00
350	CROSS-OVER HOLE THROUGH BEAMS TO EXTEND AIR SUPPLY/RETURN DUCTING	EACH	1,574.00
351	2 TON WALL MOUNT HEAT PUMP UNIT	EACH	4,720.00
352	4 TON WALL MOUNT HEAT PUMP UNIT	EACH	5,560.00
353	5 TON WALL MOUNT HEAT PUMP UNIT	EACH	6,084.00
354	4 TON ROOF MOUNT HEAT PUMP UNIT	EACH	24,127.00
355	5 TON ROOF MOUNT HEAT PUMP UNIT	EACH	25,176.00
356	4 TON ROOF MOUNT GAS PACK UNIT	EACH	25,176.00
357	5 TON ROOF MOUNT GAS PACK UNIT	EACH	26,225.00
358	4 TON INTERIOR HEAT PUMP UNIT	EACH	16,260.00
359	5 TON INTERIOR HEAT PUMP UNIT	EACH	17,308.00
360	4 TON "QUIET CLIMATE I" WALL MOUNT HEAT PUMP	EACH	9,966.00
361	5 TON "QUIET CLIMATE I" WALL MOUNT HEAT PUMP	EACH	11,015.00
362	4 TON "QUIET CLIMATE II" WALL MOUNT HEAT PUMP	EACH	12,064.00
363	5 TON "QUIET CLIMATE II" WALL MOUNT HEAT PUMP	EACH	13,113.00
364	WAG 40 GAS HVAC UNIT IN LIEU OF 3.5 TON WALL MOUNT HEAT PUMP	EACH	6,084.00
365	UPGRADE TO QTEC 4T PACKAGED HEAT PUMP	EACH	14,686.00
366	UPGRADE TO QTEC 5T PACKAGED HEAT PUMP	EACH	16,784.00
367	UPGRADE TO ITEC 4T INDOOR HEAT PUMP	EACH	23,078.00
368	UPGRADE TO ITEC 5T INDOOR HEAT PUMP	EACH	28,323.00
369	SPLIT SYSTEM 3 TON HEAT PUMP WITH CLOSET MOUNTED AIR HANDLER (NIC: CLOSET AND CONNECTIONS TO CONDENSING UNIT)	EACH	34,617.00
370	SPLIT SYSTEM 4 TON HEAT PUMP WITH CLOSET MOUNTED AIR HANDLER (NIC: CLOSET AND CONNECTIONS TO CONDENSING UNIT)	EACH	38,813.00
371	SPLIT SYSTEM 5 TON HEAT PUMP WITH CLOSET MOUNTED AIR HANDLER (NIC: CLOSET AND CONNECTIONS TO CONDENSING UNIT)	EACH	44,058.00
372	PER UNIT 3 PHASE UPGRADE	EACH	1,364.00
373	PER UNIT BARD UPGRADE (WALL MOUNT)	EACH	1,574.00
374	12 SEER UPGRADE	PER HVAC UNIT	4,720.00
375	AIR PURIFIER	EACH	4,720.00

BID FORM-2: ATTACHMENT B - ADDENDUM #1

2021 DISTRICT-WIDE CONTRACT FOR THE PURCHASE, RELOCATION, DISMANTLING AND REMOVAL OF DIVISION OF THE STATE ARCHITECT (DSA) APPROVED PORTABLE BUILDINGS, SSPU #40-04/2020-21

376	SUPPLY AIR REGISTER AND 10' OF FLEX DUCT	EACH	210.00
377	RETURN AIR REGISTER AND 10' OF FLEX DUCT	EACH	210.00
378	ADD FLEX DUCTING BY LINEAR FOOT	LINEAR FOOT	37.00
379	HARD GALVANIZED DUCTING UPGRADE	LINEAR FOOT	157.00
380	SMOKE / FIRE DAMPERS	EACH	3,462.00
381	BAROMETRIC RELIEF DAMPER	EACH	829.00
382	HVAC RETURN AIR PLENUM CHASE WALL	LINEAR FOOT	262.00
383	CEILING MOUNT FAN (100 CFM) WITH DUCT	EACH	787.00
384	KITCHEN EXHAUST FAN COOK VCR-XP-180 2050 CFM (OR EQUAL)	EACH	14,686.00
385	KITCHEN SUPPLY FAN, COOK 120KSP-B 220 CFM (OR EQUAL)	EACH	15,210.00
386	EXHAUST FAN COOK ACEB 70C2B (OR EQUAL)	EACH	20,455.00
387	INSECT CONTROL FAN - 3' (WITH POWER CIRCUIT)	EACH	5,665.00
388	SAFETY RAILS FOR HVAC	LINEAR FOOT	1,154.00
389	MAKE-UP AIR	PER HVAC UNIT	4,616.00
390	VENTILATION HOOD	EACH	2,203.00
391	ECONOMIZER FOR WALL HUNG HVAC UNIT	PER HVAC UNIT	4,720.00
392	HVAC ISOLATION CURB (EXTERIOR) FOR NOISE REDUCTION	PER HVAC UNIT	2,937.00
PLUMBING			
393	INTERIOR UNISEX TOILET ROOM	EACH	9,861.00
394	INTERIOR PRIMARY UNISEX TOILET	EACH	10,385.00
395	INSTANT FLOW ELECTRIC TANK LESS WATER HEATER	EACH	682.00
396	6 GAL ELECT WATER HEATER	EACH	1,783.00
397	10 GAL ELECT WATER HEATER	EACH	1,678.00
398	30 GAL ELECT WATER HEATER	EACH	2,623.00
399	GAS PIPING	LINEAR FOOT	44.00
400	GAS TURRETS	EACH	881.00
401	CAST IRON DRAIN LINES	LINEAR FOOT	65.00
402	ACID RESISTANT WASTE PIPING	LINEAR FOOT	100.00
403	FLOOR DRAINS	EACH	1,049.00
404	HOSE BIB (RECESSED WITH LOCKING COVER)	EACH	734.00
405	PLUMB WALL FOR FIXTURE WITH SUPPLY LINE(S) AND DRAIN LINES	EACH	734.00
406	DRINKING FOUNTAIN DUAL WALL MOUNTED INTERIOR	EACH	3,357.00
407	DRINKING FOUNTAIN DUAL WALL MOUNTED EXTERIOR	EACH	5,770.00
408	LAVATORY WALL HUNG VITREOUS CHINA 19" X 17" WITH CARRIERS	EACH	970.00
409	TOILET WALL HUNG VITREOUS CHINA FLUSH VALVE ADA / STANDARD	EACH	1,416.00
410	FLUSH VALVE TOILET OR URINAL	EACH	1,154.00
411	CLASSROOM SINK	EACH	1,574.00
412	BUBBLER FOR SINK	EACH	357.00
413	SINGLE BOWL STAINLESS STEEL SINK WITH SINGLE LEVER FAUCET	EACH	2,203.00
414	DOUBLE BOWL STAINLESS STEEL SINK WITH SINGLE LEVER FAUCET	EACH	2,413.00
415	THREE BOWL 55 COMM. SINK W/ DRAIN BOARDS AND FAUCET	EACH	7,763.00
416	MOP SINK FIBERGLASS W/ LEGS & SWING FAUCET	EACH	1,521.00
417	MOP SINK FLOOR MOUNTED WITH WALL FAUCET	EACH	1,678.00
418	36" X 36" FIBERGLASS SHOWER UNIT WITH FLOOR UNIT	EACH	4,406.00
419	FIBERGLASS ADA SHOWER STALL WITH ADA LIP AND SEAT	EACH	5,402.00
420	IN SINK GARBAGE DISPOSAL	EACH	881.00
421	EMERGENCY EYE WASH	EACH	8,287.00
422	FIXTURE HOLES THROUGH CONCRETE FLOOR	EACH	220.00
423	ADULT HANDICAP WATER CLOSET (INCLUDES GRAB BAR) STANDARD	EACH	997.00
424	ROUGH-IN GAS LINE	LINEAR FOOT	944.00
425	URINAL WALL MOUNTED	EACH	1,285.00
426	ROUGH-IN FOR FUTURE FUME HOOD (APPLIANCE, INSTALLATION AND HARDWARE BY OTHERS)	EACH	1,731.00
427	ROUGH-IN FOR FUTURE VENT (APPLIANCE, INSTALLATION AND HARDWARE BY OTHERS)	EACH	682.00
428	ACID WASTE PIPING (UTILITY CONNECTION, TANK AND ACCESSORIES NIC)	EACH FITTING	703.00

BID FORM-2: ATTACHMENT B - ADDENDUM #1

2021 DISTRICT-WIDE CONTRACT FOR THE PURCHASE, RELOCATION, DISMANTLING AND REMOVAL OF DIVISION OF THE STATE ARCHITECT (DSA) APPROVED PORTABLE BUILDINGS, SSPU #40-04/2020-21

429	UPGRADE CHEM-SURF RESISTANT SINGLE BOWL SINK	EACH	1,888.00
430	WATER CLOSET, FLOOR MOUNT, TANK TYPE	EACH	1,154.00
431	WATER CLOSET, FLOOR MOUNT, FLUSH VALVE	EACH	1,678.00
432	WATER CLOSET, WALL HUNG, FLUSH VALVE	EACH	2,203.00
433	WATER CLOSET, CHILD 10" HEIGHT, FLOOR MOUNTED, FLUSH VALVE	EACH	2,308.00
434	WATER CLOSET, CHILD 10" HEIGHT, FLOOR MOUNTED, TANK TYPE	EACH	1,574.00
435	URINAL WATERLESS	EACH	2,413.00
436	RECESSED ICE MAKER BOX	EACH	839.00
437	COPPER PIPE, TYPE "L" ROUGH IN AND FIXTURE FITTING	EACH	881.00
438	UPGRADE TO ELECTRONIC SENSOR FLUSH VALVE TOILET OR URINAL	EACH	913.00
439	UPGRADE TO ELECTRONIC SENSOR FAUCETS	EACH	734.00
440	ADD FOR POINT OF CONNECTIONS	EACH	944.00
441	PLUMBING MANIFOLD	PER FIXTURE	105.00
TOILET PARTITIONS AND ACCESSORIES			
442	STEEL ADA PRIVACY PARTITIONS WITH ENAMEL FINISH	EACH	2,308.00
443	STEEL STANDARD PRIVACY STALL WITH ENAMEL FINISH	EACH	2,308.00
444	STEEL PRIVACY SCREEN 54 X 58 WITH ENAMEL FINISH	EACH	787.00
445	STEEL URINAL SCREEN 24 X 42 WITH ENAMEL FINISH	EACH	787.00
446	UPGRADE SOLID PLASTIC PARTITIONS NON-ADA COMPARTMENT	EACH	734.00
447	UPGRADE SOLID PLASTIC PARTITIONS ADA COMPARTMENT	EACH	734.00
448	UPGRADE SOLID PLASTIC PARTITIONS URINAL SCREEN	EACH	315.00
449	FULL-HEIGHT PARTITIONS UPGRADE	EACH	2,518.00
450	GRAB BARS	EACH	210.00
451	LIQUID SOAP DISPENSER, SURFACE MOUNTED	EACH	199.00
452	TOILET PAPER DISPENSER, SURFACE MOUNTED, SINGLE ROLL	EACH	892.00
453	TOILET PAPER DISPENSER, SURFACE MOUNTED, MULTI-ROLL	EACH	1,574.00
454	TOILET PAPER DISPENSER, SEMI-RECESSED, MULTI-ROLL	EACH	1,888.00
455	PAPER TOWEL DISPENSER, SURFACE MOUNTED	EACH	525.00
456	PAPER TOWEL DISPENSER, RECESSED (FOLDED TOWELS)	EACH	787.00
457	PAPER TOWEL AND WASTE DISPENSER, RECESSED (4" WALL)	EACH	1,888.00
458	ELECTRIC HAND DRYER (WITH POWER CIRCUIT)	EACH	1,993.00
459	WASTE RECEPTACLE, SURFACE MOUNTED	EACH	944.00
460	SANITARY NAPKIN RECPTACLE, SURFACE MOUNTED	EACH	525.00
461	DIAPER CHANGING STATION, SURFACE MOUNTED	EACH	1,941.00
462	MOP AND BROOM HOLDER	EACH	472.00
CABINETRY			
463	PLUMBED SINK AND CABINET W/BUBBLER & FAUCET	EACH	3,671.00
464	BASE CABINET L36 X H36 X D24	EACH	1,049.00
465	BASE CABINET L48 X H36 X D24 (NO DOORS)	EACH	1,364.00
466	DRAWER BASE CAN L36 X H36 X D24	EACH	1,469.00
467	DRAWER BASE CAN L24 X H36 X D24	EACH	1,154.00
468	WALL HUNG CAB L30 X H30 X D12	EACH	734.00
469	OPEN UPPER CABINET L30 X H30 X D12	EACH	787.00
470	UPPER CABINET WITH DOORS L36 X H84 X D24	EACH	829.00
471	OPEN TALL STORAGE CABINET L36 X H84 X D24	EACH	1,154.00
472	LOCKABLE TALL STORAGE CABINET L36 X H84 X D24	EACH	1,469.00
473	TALL STORAGE WITH DOORS L36X H84 X D24	EACH	1,469.00
474	TALL TEACHER CABINET L48 X H84 X D24	EACH	1,678.00
475	16' TEACHING WALL	EACH	10,805.00
476	20' TEACHING WALL	EACH	15,735.00
477	ADD FOR WIC CERTIFICATION	EACH	525.00
478	BENCHES	EACH	787.00
479	LOCKERS	EACH	1,888.00
480	KITCHEN	EACH	20,875.00
481	WARDROBE RACK L60 WITH 15 HOOKS (INTERIOR)	EACH	1,101.00
482	WARDROBE RACK L60 WITH 15 HOOKS (EXTERIOR)	EACH	1,101.00
483	CUBBY STORAGE L48 X H66 X D12 (48 CUBICLES)	EACH	1,993.00

BID FORM-2: ATTACHMENT B - ADDENDUM #1

2021 DISTRICT-WIDE CONTRACT FOR THE PURCHASE, RELOCATION, DISMANTLING AND REMOVAL OF DIVISION OF THE STATE ARCHITECT (DSA) APPROVED PORTABLE BUILDINGS, SSPU #40-04/2020-21

484	LOW BOOK SHELVES L36 X H42 X D9	EACH	944.00
485	HIGH PRESSURE LAMINATE COUNTER TOP	LINEAR FOOT	105.00
486	EPOXY COUNTER TOP	LINEAR FOOT	262.00
487	CABINET BLOCKING UPPER	LINEAR FOOT	29.00
488	CABINET BLOCKING LOWER	LINEAR FOOT	29.00
489	DRAWERS IN LIEU OF SHELVING AND DOORS	LINEAR FOOT	89.00
490	PLASTIC LAMINATED COUNTER TOP ONLY WITH BACKSPLASH	LINEAR FOOT	93.00
491	UPGRADE TO CHEM-SURFACE RESISTANT COUNTER TOP WITH BACKSPLASH	LINEAR FOOT	146.00
492	CASEWORK NOT INCLUDED HEREIN	LINEAR FOOT	Cost + 24.9%
FIRE PROTECTION			
493	FIRE EXTINGUISHER WITH MOUNTING BRACKET	EACH	262.00
494	FIRE EXTINGUISHER IN RECESSED STEEL CABINET	EACH	682.00
495	FIRE EXTINGUISHER IN SEMI-RECESSED STEEL CABINET	EACH	577.00
496	FIRE SPRINKLER IN OPEN BUILDING (FLOW TEST, INSPECTION NIC)	SQUARE FOOT	47.00
497	FIRE SPRINKLER RISER	EACH	3,671.00
BUILDING AND INSTALLATION MISCELLANEOUS			
498	ONE HOUR RATED SEISMIC CLOSURE	SQUARE FOOT	262.00
499	PERIMETER SKIRTING	LINEAR FOOT	26.00
500	FIRE RATED PERIMETER SKIRTING	LINEAR FOOT	115.00
501	PLUMBING SUPPLY LINE CHLORINATION	PER FIXTURE	525.00
502	CONDENSATION DRAIN LINE	EACH	682.00
503	SPLASH BLOCK	EACH	210.00
504	EXPANDED METAL VENTS	SQUARE FOOT	21.00
SCIENCE LAB OPTIONS			
505	SCIENCE WORK STATION / ISLAND	EACH	7,867.00
506	SCIENCE ROOM SINK (NIC: ACID RESISTANT PLUMBING)	EACH	3,357.00
507	SCIENCE ROOM DRY SERVICE VALVE FOR GAS (NIC: GAS CONNECTION)	EACH	934.00
508	LAB FAUCET	EACH	1,941.00
509	ACID DILUTER (UNDER SINK, SINGLE STATION)	EACH	734.00
510	SINGLE-HOLE TOP-MOUNTED SINK FOR SINGLE HOLE FAUCET, STAINLESS STEEL, ACID RESISTANT ENAMEL FINISH	LINEAR FOOT	3,304.00
511	EPOXY TOP, BLACK COUNTER TOP	LINEAR FOOT	472.00
512	STANDARD 48" FUME HOOD	EACH	29,896.00
513	LABORATORY 48" FUME HOOD (ISOLATER SERIES WITH A TOP AND BOTTOM AIROFOIL AND AERODYNAMICALLY SHAPED FASCIA POSTS TO MINIMIZE TURBULENCE)	EACH	40,911.00
CEMENT BASED OR STUCCO EXTERIOR FINISHES			
514	CEMENT BOARD SIDING OVER 1/2" SHEATHING (4' X 8') (HARDIE PANEL, OR EQUALIVENT) - EXCLUDES REMOVAL OF EXISTING SIDING	SQUARE FOOT	9.00
515	REMOVAL OF EXISTING EXTERIOR SIDING	SQUARE FOOT	5.25
516	EXTERIOR PLASTER STUCCO, 3 COAT SYSTEM	SQUARE FOOT	20.00
517	ADD STUCCO DIAMOND WALL	SQUARE FOOT	1.25
518	STUCCO ACRYLIC	SQUARE FOOT	21.00
MISCELLANEOUS EXTERIOR FINISHES			
519	1/2" CDX PLYWOOD (FOR USE UNDER EXTERIOR CEMENTITIOUS PRODUCTS)	SQUARE FOOT	3.25
520	PAINT EXTERIOR OFF SITE (STANDARD PAINT)	SQUARE FOOT	4.75
521	ON-SITE PAINTING (STANDARD PAINT)	SQUARE FOOT	10.00
522	PAINT EXTERIOR OFF SITE (CUSTOM COLOR)	SQUARE FOOT	8.00
523	ON-SITE PAINTING (CUSTOM COLOR)	SQUARE FOOT	14.00
524	UPGRADE PAINT TO DUNN EDWARDS	SQUARE FOOT	3.25
525	METAL ROOF AND WALL CLOSURE BETWEEN BUILDINGS, UP TO 6"	LINEAR FOOT	10.50
526	FIXED WOOD CLOSURE PANEL BETWEEN BUILDINGS, UP TO 2'	EACH	472.00
527	OPERABLE WOOD CLOSURE PANEL BETWEEN BUILDINGS, UP TO 2'	EACH	682.00
RAMPS AND LANDING PURCHASE			
528	5 X 7 LANDING W/ 4 X 11 RAMP W/ HAND RAILS ATTACHED TO BUILDING - METAL	EACH	3,252.00
529	5 X 7 LANDING W/ 4 X 11 RAMP W/ HAND RAILS OFFSET FROM BUILDING - METAL	EACH	3,881.00

BID FORM-2: ATTACHMENT B - ADDENDUM #1

2021 DISTRICT-WIDE CONTRACT FOR THE PURCHASE, RELOCATION, DISMANTLING AND REMOVAL OF DIVISION OF THE STATE ARCHITECT (DSA) APPROVED PORTABLE BUILDINGS, SSPU #40-04/2020-21

530	5 X 7 LANDING W/ 4 X 11 RAMP W/ HAND RAILS ATTACHED TO BUILDING - ALUMINUM	EACH	6,084.00
531	5 X 7 LANDING W/ 4 X 11 RAMP W/ HAND RAILS OFFSET FROM BUILDING - ALUMINUM	EACH	6,714.00
532	34 X 6.6 LANDING W/ 5 X 7 LANDING W/ 4 X 14 RAMP W/ HAND RAIL - METAL	LINEAR FOOT	7,867.00
533	RAMP EXTENSION W/ HAND RAILS ATTACHED TO BUILDING - METAL	LINEAR FOOT	1,364.00
534	RAMP EXTENSION W/ HAND RAILS OFFSET FROM BUILDING - METAL	LINEAR FOOT	1,574.00
535	RAMP EXTENSION W/ HAND RAILS ATTACHED TO BUILDING - ALUMINUM	LINEAR FOOT	2,623.00
536	RAMP EXTENSION W/ HAND RAILS OFFSET FROM BUILDING - ALUMINUM	LINEAR FOOT	3,672.00
537	ADD A STEEL 3 STEP RISER W/ HAND RAILS - METAL	EACH	1,574.00
538	ADD A STEEL 3 STEP RISER W/ HAND RAILS - ALUMINUM	EACH	2,937.00
539	SWITCH BACK EXTENSION TO STANDARD METAL RAMP & LANDING - METAL	EACH	3,986.00
540	SWITCH BACK EXTENSION TO STANDARD METAL RAMP & LANDING - ALUMINUM	EACH	6,714.00
541	UPGRADE RAMP MATERIALS TO DIAMOND PLATE	SQUARE FOOT	73.00
542	CONCRETE 4 X 11 RAMP AND 5 X 7 LANDING W/ HAND RAIL	EACH	9,965.00
543	EXTEND CONCRETE RAMP OR LANDING W/ HAND RAIL	LINEAR FOOT	420.00
RAMPS AND LANDINGS ANNUAL LEASE			
544	5 X 7 LANDING W/ 4 X 11 RAMP W/ HAND RAILS ATTACHED TO BUILDING - METAL	PER YEAR	1,574.00
545	5 X 7 LANDING W/ 4 X 11 RAMP W/ HAND RAILS OFFSET FROM BUILDING - METAL	PER YEAR	1,888.00
546	5 X 7 LANDING W/ 4 X 11 RAMP W/ HAND RAILS ATTACHED TO BUILDING - ALUMINUM	PER YEAR	2,623.00
547	5 X 7 LANDING W/ 4 X 11 RAMP W/ HAND RAILS OFFSET FROM BUILDING - ALUMINUM	PER YEAR	3,042.00
548	34 X 6.6 LANDING W/ 5 X 7 LANDING W/ 4 X 14 RAMP W/ HAND RAIL - METAL	PER YEAR	4,721.00
549	RAMP EXTENSION W/ HAND RAILS ATTACHED TO BUILDING - METAL	PER YEAR	525.00
550	RAMP EXTENSION W/ HAND RAILS OFFSET FROM BUILDING - METAL	PER YEAR	734.00
551	RAMP EXTENSION W/ HAND RAILS ATTACHED TO BUILDING - ALUMINUM	PER YEAR	1,259.00
552	RAMP EXTENSION W/ HAND RAILS OFFSET FROM BUILDING - ALUMINUM	PER YEAR	1,888.00
553	ADD A STEEL 3 STEP RISER W/ HAND RAILS - METAL	PER YEAR	734.00
554	ADD A STEEL 3 STEP RISER W/ HAND RAILS - ALUMINUM	PER YEAR	1,574.00
555	SWITCH BACK EXTENSION TO STANDARD METAL RAMP & LANDING - METAL	PER YEAR	1,574.00
556	SWITCH BACK EXTENSION TO STANDARD METAL RAMP & LANDING - ALUMINUM	PER YEAR	1,888.00
MISCELLANEOUS TWO STORY - PURCHASE			
557	OMITTED - VIA ADDENDUM #1		N/A
558	OMITTED - VIA ADDENDUM #1		N/A
559	OMITTED - VIA ADDENDUM #1		N/A
560	OMITTED - VIA ADDENDUM #1		N/A
MISCELLANEOUS TWO STORY ANNUAL LEASE			
561	OMITTED - VIA ADDENDUM #1		N/A
562	OMITTED - VIA ADDENDUM #1		N/A
563	OMITTED - VIA ADDENDUM #1		N/A
564	OMITTED - VIA ADDENDUM #1		N/A
MISCELLANEOUS			
565	LIGHT WEIGHT CONCRETE WATER PROOF COATING	SQUARE FOOT	7.50
566	CONCRETE BOOM PUMP	EACH	8,916.00
567	CONCRETE ACCESS / VENT WELL	EACH	3,672.00
568	RODENT SLAB	SQUARE FOOT	7.00
569	VAPOR BARRIER	SQUARE FOOT	5.25
570	FLATWORK 4" THICK REINFORCED CONCRETE (200 SQUARE FOOT MINIMUM)	SQUARE FOOT	12.75
571	SURVEY (MINIMUM 4 HOURS)	PER HOUR	462.00
572	EXCAVATION FOR FOUNDATION	CUBIC YARD	577.00
573	SPOIL REMOVAL - GENERAL 40-YARD CONTAINER	CUBIC YARD	33.00
574	SPOIL REMOVAL / SITE DEBRIS / RECORDED	CUBIC YARD	55.00
575	DRYWELL FOR CONDENSATION LINES	EACH	839.00
576	EQUIPMENT RENTAL SMALL (8 HOUR MINIMUM)	HOURLY	734.00

BID FORM-2: ATTACHMENT B - ADDENDUM #1

2021 DISTRICT-WIDE CONTRACT FOR THE PURCHASE, RELOCATION, DISMANTLING AND REMOVAL OF DIVISION OF THE STATE ARCHITECT (DSA) APPROVED PORTABLE BUILDINGS, SSPU #40-04/2020-21

577	EQUIPMENT RENTAL MEDIUM (8 HOUR MINIMUM)	HOUR	839.00
578	EQUIPMENT RENTAL LARGE (8 HOUR MINIMUM)	HOUR	892.00
579	FORKLIFT AT JOB SITE (PER DAY)	PER DAY	682.00
580	DUMPSTER (40FT ROLL OFF) PER ROLL OFF/LOAD	PER LOAD	1,467.00
581	TEMP TOILET PER MONTH	EACH MO	315.00
582	DAILY CREW PER DIEM OUTSIDE 100 MILES	PER DAY	976.00
583	UNION RATE - PREVAILING WAGE LABOR PER HOUR (MINIMUM 4 HOURS)	PER HOUR	210.00
584	STANDARD - PREVAILING WAGE LABOR PER HOUR (MINIMUM 4 HOURS)	PER HOUR	184.00
585	CONTRACT AND PROJECT SUPERVISION	PER HOUR	147.00
586	ENGINEERING & DESIGN	PER HOUR	220.00
587	PERFORMANCE AND PAYMENT BONDS (% OF P.O. TOTAL)	PERCENT	2.6%
588	COURSE OF CONSTRUCTION / BUILDERS RISK MISC. INS. (% ABOVE COST)	PERCENT	10.5%
589	UNFORESEEN ITEMS NOT ITEMIZED (% ABOVE COST)	PERCENT	15.7%
590	DSA MEETING / TRIP COST	FEE	1,259.00
591	CALC FEES (STRUCTURAL, FIRE SPRINKLERS, HVAC, ETC.)	EACH	734.00
592	EXCESS LABOR DUE TO UNFORSEEN SITE CONDITIONS	PER DAY	944.00
593	GENERAL CLEANING	PER DAY	839.00
	DELIVERY SERVICE CAL TRANS APPROVED ROUTES RATES FOR UP TO 40' MODULE (ALSO FOR RETURN DELIVERY SERVICE)		
594	0-30	EACH	787.00
595	31-40	EACH	787.00
596	41-50	EACH	839.00
597	51-60	EACH	839.00
598	61-70	EACH	892.00
599	71-80	EACH	1,888.00
600	81-90	EACH	2,098.00
601	91-100	EACH	2,308.00
602	101-115	EACH	2,518.00
603	116-130	EACH	2,727.00
604	131-145	EACH	2,937.00
605	146-160	EACH	3,147.00
606	161-180	EACH	3,357.00
607	181-200	EACH	3,567.00
608	201-225	EACH	3,776.00
609	226-250	EACH	3,986.00
610	251-275	EACH	3,986.00
611	276-300	EACH	4,196.00
612	301-325	EACH	4,301.00
613	326-350	EACH	4,406.00
614	351-375	EACH	4,511.00
615	376-400	EACH	4,616.00
616	401-425	EACH	4,720.00
617	426-450	EACH	4,825.00
618	451-475	EACH	4,930.00
619	476-500	EACH	5,035.00
620	501-525	EACH	5,140.00
621	526-550	EACH	5,245.00
622	551-755	EACH	5,350.00
623	576-600	EACH	5,455.00
624	601-625	EACH	5,560.00
625	626-650	EACH	5,665.00
626	651-675	EACH	5,769.00
627	676-700	EACH	5,874.00
628	701-725	EACH	5,979.00
629	726-750	EACH	6,084.00
630	751-775	EACH	6,189.00
631	776-800	EACH	6,294.00

BID FORM-2: ATTACHMENT B - ADDENDUM #1

2021 DISTRICT-WIDE CONTRACT FOR THE PURCHASE, RELOCATION, DISMANTLING AND REMOVAL OF DIVISION OF THE STATE ARCHITECT (DSA) APPROVED PORTABLE BUILDINGS, SSPU #40-04/2020-21

632	801-825	EACH	6,504.00
633	ADD FOR 60' MODULE / OVERSIZE 12'+	EACH	2,098.00
634	PILOT CAR PER MODULE UP TO 50 MILES	EACH	315.00
635	POLE CAR PER MODULE UP TO 50 MILES	EACH	472.00
636	CABLE TRAILER UPGRADE	EACH	2,098.00
637	PERMITS AND FEES	EACH	524.00
	RELOCATION INSTALLATION SERVICES		
638	12 X 40 BUILDING RELOCATION	EACH	12,903.00
639	24 X 40 BUILDING RELOCATION	EACH	13,847.00
640	ADDITIONAL 12 X 40 MODULE RELOCATION	EACH	7,867.00
641	30 X 32 BUILDING RELOCATION	EACH	15,735.00
642	ADDITIONAL 10 X 32 MODULE RELOCATION	EACH	7,867.00
643	24 X 60 BUILDING RELOCATION	EACH	16,259.00
644	ADDITIONAL 12 X 60 MODULE RELOCATION	EACH	8,916.00
645	SIDE LOADS SERVICE AT SITE PER MODULE	EACH	525.00
646	REVERSE LOADS SERVICE AT SITE PER MODULE	EACH	525.00
647	MODULE ROLLING SERVICE AT SITE PER MODULE	EACH	577.00
648	MODULE SHUTTLE SERVICE AT SITE PER MODULE	EACH	472.00
649	CRANING AND RIGGING (4 HOUR MINIMUM) PER HOUR	EACH	1,469.00

THIS ENDORSEMENT CHANGES THE POLICY. PLEASE READ IT CAREFULLY.

ADDITIONAL INSURED – OWNERS, LESSEES OR CONTRACTORS – AUTOMATIC STATUS FOR OTHER PARTIES WHEN REQUIRED IN WRITTEN CONSTRUCTION AGREEMENT

This endorsement modifies the policy by adding the following terms and conditions.

CMMCGT

A. Section II - Who Is An Insured

Who Is An Insured

1. The policy shall cover the named insured and any other party who is an additional insured under the policy as a result of a written construction agreement between the named insured and the additional insured.
2. The policy shall cover the named insured and any other party who is an additional insured under the policy as a result of a written construction agreement between the named insured and the additional insured.

The policy shall cover the named insured and any other party who is an additional insured under the policy as a result of a written construction agreement between the named insured and the additional insured.

- a. The policy shall cover the named insured and any other party who is an additional insured under the policy as a result of a written construction agreement between the named insured and the additional insured.
- b. The policy shall cover the named insured and any other party who is an additional insured under the policy as a result of a written construction agreement between the named insured and the additional insured.

The policy shall cover the named insured and any other party who is an additional insured under the policy as a result of a written construction agreement between the named insured and the additional insured.

The policy shall cover the named insured and any other party who is an additional insured under the policy as a result of a written construction agreement between the named insured and the additional insured.

- a. The policy shall cover the named insured and any other party who is an additional insured under the policy as a result of a written construction agreement between the named insured and the additional insured.
- b. The policy shall cover the named insured and any other party who is an additional insured under the policy as a result of a written construction agreement between the named insured and the additional insured.

The policy shall cover the named insured and any other party who is an additional insured under the policy as a result of a written construction agreement between the named insured and the additional insured.

B. Who Is An Insured

Who Is An Insured

The policy shall cover the named insured and any other party who is an additional insured under the policy as a result of a written construction agreement between the named insured and the additional insured.

1. "Additional insured" means any party who is an additional insured under the policy as a result of a written construction agreement between the named insured and the additional insured.

- a. The policy shall cover the named insured and any other party who is an additional insured under the policy as a result of a written construction agreement between the named insured and the additional insured.

- b. The policy shall cover the named insured and any other party who is an additional insured under the policy as a result of a written construction agreement between the named insured and the additional insured.

The policy shall cover the named insured and any other party who is an additional insured under the policy as a result of a written construction agreement between the named insured and the additional insured.

2. "Additional insured" means any party who is an additional insured under the policy as a result of a written construction agreement between the named insured and the additional insured.

- a. The policy shall cover the named insured and any other party who is an additional insured under the policy as a result of a written construction agreement between the named insured and the additional insured.

FAITHFUL PERFORMANCE BOND – Bond # _____

KNOW ALL PERSONS BY THESE PRESENT:

WHEREAS, the Savanna School District of Orange County, California (hereinafter referred to as "DISTRICT"), awarded to _____ (hereinafter referred to as the "Contractor/Principal") the contract for the work described as 2021 District-Wide Contract for the Purchase, Lease, Relocate, Dismantling, and Removal of Division of the State (DSA) Approved Portable Buildings, Project No. SSPU, #40-04/2020-21.

WHEREAS, said Contractor/Principal is required under the terms of said contract to furnish a bond for the faithful performance of said contract which contract is incorporated herein by reference;

NOW, THEREFORE, we the undersigned Contractor, as Principal, and Surety, a California admitted surety insurer are held and firmly bound to the DISTRICT for \$ _____ which equals one hundred percent (100%) of the total amount payable by the DISTRICT under the terms of the contract for each and every purchase order over the amount of twenty-five thousand dollars (\$25,000.00) when the cost of the bond is specifically included in the scope and cost of the project on the line item included on the Bid Form-2 Quotation, executed against this unit price agreement, awarded by the DISTRICT to the Contractor/Principal, lawful money of the United States of America, for payment of which sum well and truly to be made, we bind ourselves, our heirs, executors, administrators and successors, jointly and severally, firmly by these presents.

THE CONDITION OF THIS OBLIGATION IS SUCH THAT, if the hereby bonded Contractor/Principal, its heirs, executors, administrators, successors, or assigns, shall in all things stand to and abide by and well and truly keep and perform all the undertakings, terms, covenants, conditions, and agreements in the said contract which is attached hereto and incorporated herein by reference and any alteration and/or amendments thereof, made as therein provided, including, but not limited to, the provisions regarding contract duration and liquidated damages, all within the time and in the manner therein designated in all respects according to their true intent and meaning, then this obligation shall become null and void; otherwise, it shall be and remain in full force and effect.

As a condition precedent to the satisfactory completion of the contract, the above obligation shall hold good for a period of one (1) year(s) after the acceptance of the work by DISTRICT, during which time if Contractor/Principal shall fail to make full, complete, and satisfactory repair and replacements and totally protect the DISTRICT from loss or damage made evident during the period of one (1) year(s) from the date of completion of the work, and resulting from or caused by defective materials or faulty workmanship, the above obligation in penal sum thereof shall remain in full force and effect. The obligation of Surety hereunder shall continue so long as any obligation of Contractor remains.

Whenever Contractor/Principal shall be, and is declared by the DISTRICT to be, in default under the contract, the DISTRICT having performed the DISTRICT's obligations thereunder, the Surety shall promptly remedy the default, or shall promptly:

1. Complete the contract in accordance with its terms and conditions; or

2. Obtain a bid or bids for completing the contract in accordance with its terms and conditions, and upon determination by Surety of the lowest responsive and responsible bidder, arrange for a contract between such bidder and the DISTRICT, and make available as work progresses sufficient funds to pay the cost of completion less the balance of the contract price, but not exceeding, including other costs and damages for which Surety may be liable hereunder, the amount set forth above. The term "balance of the contract price" as used in this paragraph shall mean the total amount payable to Contractor/Principal by the DISTRICT under the contract and any modifications thereto, less the amount previously properly paid by the DISTRICT to the Contractor/Principal.

Surety expressly agrees that the DISTRICT may reject any contractor or subcontractor which may be proposed by Surety in fulfillment of its obligations in the event of default by the Principal. Surety shall not utilize Contractor/Principal in completing the contract nor shall Surety accept a bid from Contractor/Principal for completion of the work if the DISTRICT, when declaring the Contractor/Principal in default, notifies Surety of the DISTRICT's objection to Contractor's/Principal's further participation in the completion of the work.

No right of action shall accrue on this bond to or for the use of any person or corporation other than the DISTRICT named herein or the successors or assigns of the DISTRICT. Any suit under this bond must be instituted within the applicable statute of limitations period.

FURTHER, the said Surety, for value received, hereby stipulates and agrees that no change, extension of time, alteration or modification of the Project documents, or of the work to be performed thereunder, shall in any way affect its obligations on this bond; and it does hereby waive notice of any change, extension of time, alteration or modification of the Project documents or of work to be performed thereunder.

Contractor/Principal and Surety agree that if the DISTRICT is required to engage the services of an attorney in connection with the enforcement of this bond, each shall pay DISTRICT's reasonable attorney's fees and costs incurred, with or without suit, in addition to the above amount.

IN WITNESS WHEREOF, we have hereunto set our hands and seals this _____ day of _____, 20__.

CORPORATE SEAL, IF
APPLICABLE, AND NOTARIAL
ACKNOWLEDGEMENT OF
CONTRACTOR

Contractor/Principal

By: _____
Signature

Print Name and Title

SEAL AND NOTARIAL
ACKNOWLEDGEMENT OF
SURETY

(Mailing Address, Telephone
No. and Email of Surety)

(Attach Attorney-in-Fact Certificate
and Required Acknowledgement)

Surety

By: _____
Signature

Print Name and Title

Contact Data for Local Agent:

Name

Street Address

City

Zip Code

Telephone No.

Email

PAYMENT BOND # _____

KNOW ALL PERSONS BY THESE PRESENT:

WHEREAS, the Savanna School District of Orange County, California ("hereinafter referred to as DISTRICT"), has awarded to _____, hereinafter referred to as the "Contractor/Principal" a contract for the work described as 2021 District-Wide Contract for the Purchase, Lease, Relocate, Dismantling, and Removal of Division of the State (DSA) Approved Portable Buildings, Project No. SSPU, #40-04/2020-21.

WHEREAS, said Contractor/Principal is required by Division 3, Part IV, Title XV, Chapter 7 (commencing at Section 3247) of the California Civil Code to furnish a bond in connection with said contract;

NOW, THEREFORE, we, the Contractor/Principal and _____, as Surety, a California admitted surety insurer, are held firmly bound unto the DISTRICT for \$ _____ which equals one hundred percent (100%) of the total amount payable by the DISTRICT under the terms of the contract for each and every purchase order over the amount of twenty-five thousand dollars (\$25,000.00) when the cost of the bond is specifically included in the scope and cost of the project on the line item included on the Bid Form-2 Quotation, executed against this unit price agreement awarded by the DISTRICT to the Contractor/Principal lawful money of the United States of America for the payment of which sum well and truly to be made, we bind ourselves, our heirs, executors, administrators, successors and assigns, jointly and severally, firmly by these presents.

THE CONDITION OF THIS OBLIGATION IS SUCH that if said Contractor/Principal, his/her or its heirs, executors, administrators, successors, or assigns, or a subcontractor, shall fail to pay any person or persons named in Civil Code Section 3181 or fail to pay for any materials, or other supplies, used in, upon, for, or about the performance of the work contracted to be done, or for any work or labor thereon of any kind, or for amounts due under the Unemployment Insurance Code, with respect to work or labor thereon of any kind, or shall fail to deduct, withhold, and pay over to the Employment Development Department, any amounts required to be deducted, withheld, and paid over by Section 13020 of the Unemployment Insurance Code with respect to work and labor thereon of any kind, then said Surety will pay for the same, in or to an amount not exceeding the amount hereinabove set forth, and also will pay in case suit is brought upon this bond, such reasonable attorney's fees as shall be fixed by the court, awarded and taxed as provided in Division 3, Part IV, Title XV, Chapter 7 (commencing at Section 3247) of the California Civil Code.

This bond shall inure to the benefit of any of the persons named in Section 3181 of the California Civil Code, so as to give a right of action to such person or their assigns in any suit brought upon this bond.

It is further stipulated and agreed that the Surety of this bond shall not be exonerated or released from the obligation of the bond by any change, extension of time for performance, addition, alteration or modification in, to, or of any contract, plans, specifications, or agreement pertaining or relating to any scheme or work of improvement hereinabove described or pertaining or relating to the furnishing of labor, materials, or equipment therefore, nor by any change or modification of any terms of payment or extension of the time for any payment pertaining or relating to any scheme or

work of improvement hereinabove described, nor by any rescission or attempted rescission of the contract, agreement or bond, nor by any conditions precedent or subsequent in the bond attempting to limit the right of recovery of claimants otherwise entitled to recover under any such contract or agreement or under the bond, nor by any fraud practiced by any person other than the claimant seeking to recover on the bond and that this bond be construed most strongly against the Surety and in favor of all persons for whose benefit such bond is given, and under no circumstances shall Surety be released from liability to those for whose benefit such bond has been given, by reason of any breach of contract between the DISTRICT and original contractor or on the part of any obligee named in such bond, but the sole conditions of recovery shall be that claimant is a person described in Section 3110 and 3112 of the California Civil Code, and has not been paid the full amount of his/her or its claim and that Surety does hereby waive notice of any such change, extension of time, addition, alteration or modification herein mentioned.

Any claims under this bond may be addressed to:

(Name and address of Surety)

(Name and address of agent or representative in California, if different from above)

(Telephone of Surety or agent or representative in California)

(Email for Surety or agent or representative in California)

IN WITNESS HEREOF, we have hereto set our hands and seals on this ____ day of _____, 20__.

CORPORATE SEAL, IF APPLICABLE, AND NOTARIAL ACKNOWLEDGEMENT OF CONTRACTOR

Contractor/Principal

By: _____
Signature

Print Name and Title

SEAL AND NOTARIAL ACKNOWLEDGEMENT OF SURETY

Surety

By: _____
Signature

Print Name and Title

(Mailing Address, Telephone and Email of Surety)

(Attach Attorney-in-Fact Certificate and Required Acknowledgement)

DRUG-FREE WORKPLACE CERTIFICATION

This Drug-Free Workplace Certification is required pursuant to Government Code Sections 8350, et seq., the Drug-Free Workplace Act of 1990. The Drug-Free Workplace Act of 1990 requires that every person or organization awarded a contract for the procurement of any property or services from any State agency must certify that it will provide a drug-free workplace by doing certain specified acts. In addition, the Act provides that each contract awarded by a State agency may be subject to suspension of payments or termination of the contract, and the contractor may be subject to debarment from future contracting, if the state agency determines that specified acts have occurred.

Pursuant to Government Code Section 8355, every person or organization awarded a contract from a State agency shall certify that it will provide a drug-free workplace by doing all of the following:

- a) publishing a statement notifying employees that the unlawful manufacture, distribution, dispensation, possession or use of a controlled substance is prohibited in the person's or organization's workplace and specifying actions which will be taken against employees for violations of the prohibition;
- b) establishing a drug-free awareness program to inform employees about all of the following:
 - 1) the dangers of drug abuse in the workplace;
 - 2) the person's or organization's policy of maintaining a drug-free workplace;
 - 3) the availability of drug counseling, rehabilitation and employee-assistance programs;
 - 4) the penalties that may be imposed upon employees for drug abuse violations;
- c) requiring that each employee engaged in the performance of the contract be given a copy of the statement required by subdivision (a) and that, as a condition of employment on the contract, the employee agrees to abide by the terms of the statement.

I, the undersigned, agree to fulfill the terms and requirements of Government Code Section 8355 listed above and will publish a statement notifying employees concerning (a) the prohibition of controlled substance at the workplace, (b) establishing a drug-free awareness program, and (c) requiring that each employee engaged in the performance of the contract be given a copy of the statement required by Section 8355(a) and requiring that the employee agree to abide by the terms of that statement.

I also understand that if the DISTRICT determines that I have either (a) made a false certification herein, or (b) violated this certification by failing to carry out the requirements of Section 8355, that the contract awarded herein is subject to suspension of payments, termination, or both. I further understand that, should I violate the terms of the Drug-Free Workplace Act of 1990, I may be subject to debarment in accordance with the requirements of Section 8350, et seq.

I acknowledge that I am aware of the provisions of Government Code Section 8350, et seq. and hereby certify that I will adhere to the requirements of the Drug-Free Workplace Act of 1990.

NAME OF CONTRACTOR

Signature

Print Name

Title

Date

WORKERS' COMPENSATION CERTIFICATE

Labor Code Section 3700.

"Every employer except the state shall secure the payment of compensation in one or more of the following ways:

(a) By being insured against liability to pay compensation in one or more insurers duly authorized to write compensation insurance in this state.

(b) By securing from the Director of Industrial Relations a certificate of consent to self-insure either as an individual employer or as one employer in a group of employers, which may be given upon furnishing proof satisfactory to the Director of Industrial Relations of ability to self-insure and to pay any compensation that may become due to his or her employees.

(c) For any county, city, city and county, municipal corporation, public district, public agency or any political subdivision of the state, including each member of a pooling arrangement under a joint exercise of powers agreement (but not the state itself), by securing from the Director of Industrial Relations a certificate of consent to self-insure against workers' compensation claims, which certificate may be given upon furnishing proof satisfactory to the director of ability to administer workers' compensation claims properly, and to pay workers' compensation claims that may become due to its employees. On or before March 31, 1979, a political subdivision of the state which, on December 31, 1978, was uninsured for its liability to pay compensation, shall file a properly completed and executed application for a certificate of consent to self-insure against workers' compensation claims. The certificate shall be issued and be subject to the provisions of Section 3702."

I am aware of the provisions of Labor Code Section 3700 which require every employer to be insured against liability for workers' compensation or to undertake self-insurance in accordance with the provisions of that code, and I will comply with such provisions before commencing the performance of the work of this contract.

Name of the Contractor

By: _____
Signature

Print Name

Title

Date

(In accordance with Article 5 [commencing at § 1860], Chapter 1, Part 7, Division 2 of the Labor Code, the above certificate must be signed and filed with the awarding body prior to performing any work under the contract.)

CERTIFICATION BY CONTRACTOR
CRIMINAL RECORDS CHECK (AB 1610, 1612 and 2102)

To the Governing Board of Savanna School District:

I, _____, of _____,
[Name of Contractor, or Subcontractor] [Name of Company]
certify that:

1. I have carefully read and understand the Notice of Contractors Regarding Criminal Records Checks (Education Code section 45125.1) required by the passage of AB 1610, 1612, and 2102.
2. Due to the nature of the work I will be performing on the 2021 District-Wide Contract for the Purchase, Lease, Relocate, Dismantling, and Removal of Division of the State (DSA) Approved Portable Buildings, Project SSPU, #40-04/2020-21 for the District, my employees may have contact with students of the District.
3. None of the employees who will be performing the work have been convicted of a violent or serious felony as defined in the Notice and in Penal Code section 1192.7, and this determination was made by a fingerprint check through the Department of Justice.

I declare under penalty of perjury that the foregoing is true and correct.

Executed at _____, California, on _____.
[city] [date]

[Signature]

[Typed or printed name]

[Title]

[Address & Telephone #]

[Email]

NOTICE TO CONTRACTORS REGARDING CRIMINAL RECORD CHECKS
(EDUCATION CODE SECTION 45125.1)

Education Code section 45125.1 provides that if the employees of any entity that has a contract with a school district may have any contact with pupils, those employees shall submit or have submitted their fingerprints in a manner authorized by the Department of Justice together with a fee determined by the Department of Justice to be sufficient to reimburse the Department for its costs incurred in processing the application.

The Department of Justice shall ascertain whether the individual whose fingerprints were submitted to it has been arrested or convicted of any crime insofar as that fact can be ascertained from information available to the Department. When the Department of Justice ascertains that an individual whose fingerprints were submitted to it has a pending criminal proceeding for a violent felony listed in Penal Code section 667.5(c), or a serious felony listed in Penal Code section 1192.7(c), or has been convicted of such a felony, the Department shall notify the employer designated by the individual of the criminal information pertaining to the individual. The notification shall be delivered by telephone and shall be confirmed in writing and delivered to the employer by first-class mail.

The contractor shall not permit an employee to come in contact with pupils until the Department of Justice has ascertained that the employee has not been convicted of a violent or serious felony. The contractor shall certify in writing to the governing board of the school district that none of its employees who may come in contact with pupils have been convicted of a violent or serious felony. The contractor shall provide a list of the names of its employees who may come in contact with pupils to the governing board of the school district.

Penal Code section 667.5(c) lists the following violent felonies: murder; voluntary manslaughter; mayhem; rape; sodomy by force; oral copulation by force; lewd acts on a child under the age of 14 years; any felony punishable by death or imprisonment in the state prison for life; any felony in which the defendant inflicts great bodily injury on another; any robbery perpetrated in an inhabited dwelling; arson; penetration of a person's genital or anal openings by foreign or unknown objects against the victim's will; attempted murder; explosion or attempt to explode or ignite a destructive device or explosive with the intent to commit murder; kidnapping; continuous sexual abuse of a child; and carjacking.

Penal Code section 1192.7 lists the following serious felonies: murder; voluntary manslaughter; mayhem; rape; sodomy by force; oral copulation by force; a lewd or lascivious act on a child under the age of 14 years; any felony punishable by death or imprisonment in the state prison for life; any felony in which the defendant personally inflicts great bodily injury on another, or in which the defendant personally uses a firearm; attempted murder; assault with intent to commit rape or robbery; assault with a deadly weapon on a peace officer; assault by a life prisoner on a nominate; assault with a deadly weapon by an inmate; arson; exploding a destructive device with intent to injure or to murder, or explosion causing great bodily injury or mayhem; burglary of an inhabited dwelling; robbery or bank robbery; kidnapping; holding of a hostage by a person confined in a state prison; attempt to commit a felony punishable by death or imprisonment in the state prison for life; any felony in which the defendant personally uses a dangerous or deadly weapon; selling or furnishing specified controlled substances to a minor; penetration of genital or anal openings by foreign objects against the victim's will; grand theft involving a firearm; carjacking; and a conspiracy to commit specified controlled substances offenses.

GUARANTEE

Guarantee for _____(Company). We hereby guarantee that the _____(Scope), which we have installed in the _____ project, done under the 2021 District-Wide Contract for the Purchase, Lease, Relocate, Dismantling, and Removal of Division of the State (DSA) Approved Portable Buildings, Project No. SSPU, #40-04/2020-21, has been done in accordance with the Project Documents and that the work as installed will fulfill the requirements included in the Project Documents. The undersigned agrees to repair or replace any or all of such work, together with any other adjacent work which may be displaced in connection with such repair or replacement, that may prove to be defective in workmanship or material within a period of one (1) years from the date of completion of the Project, ordinary wear and tear and unusual abuse or neglect excepted.

In the event of the undersigned's or undersigned surety's failure to commence and pursue with diligence said repairs or replacements within ten (10) calendar days after being notified in writing by the DISTRICT, the undersigned authorizes the DISTRICT to proceed to have said defects repaired or replaced and made good at the expense of the undersigned and surety who hereby agree to pay the costs and charges therefore immediately upon demand. (General Conditions Article 46(d))

Name of Contractor

By: _____
Signature of Contractor

Print Name

Title

Contractor shall provide copy of this Guarantee to Contractor's surety.

Guarantee (continued)

Name of Subcontractor
(if work performed by
subcontractor)

By: _____
Signature of Subcontractor

Print Name

Title

Representatives to be contacted for service:

Name: _____

Address: _____

Telephone Number: _____

Email: _____

**CONTRACTOR'S CERTIFICATE REGARDING
NON-ASBESTOS CONTAINING MATERIALS**

Bid No.: SSPU, #40-04/2020-21

Project: 2021 District-Wide Contract for the Purchase, Lease, Relocate, Dismantling, and Removal of
Division of the State (DSA) Approved Portable Buildings

Contractor: _____

Per Article 69 of the General Conditions, The undersigned hereby certifies to the District, subject to penalty for perjury pursuant to the laws of the State of California, that the following is true and correct:

- (a) The undersigned is a duly-authorized representative of the Contractor and, in that capacity, has executed this certification on behalf of the Contractor.
- (b) The Contractor is aware and acknowledges that, for purposes of this certification:
 - i. Asbestos is any of chrysotile, crocidolite, amosite, anthophyllite, tremolite, actinolite or other minerals generally known as asbestos; and
 - ii. An asbestos-containing material is any material or thing, or any component thereof, that contains, consists of, or is made up of greater than one-tenth of one percent (0.1%) asbestos.
- (c) The Contractor shall not use on, or incorporate into, the Project any asbestos or asbestos-containing materials, including, without limitation, in any tools, devices, clothing, or equipment used in the construction of any portion of the Project.
- (d) The Contractor has instructed its employees and subcontractors in regard to such prohibition against asbestos and asbestos-containing materials, and in regard to the hazards, risks and liabilities involved in the use of asbestos and asbestos-containing materials.
- (e) The Contractor acknowledges and agrees that:
 - i. Each dispute as to whether any material, equipment or other thing used on, or incorporated into, the Work contains asbestos or is an asbestos-containing material shall be settled by electron microscopy;
 - ii. The costs of any such tests shall be paid by the Contractor if the material is found to contain asbestos at a level greater than as specified herein; and
 - iii. The District shall reject any and all materials or other things incorporated into the Work that are determined to contain asbestos or asbestos-containing materials, and the Contractor, at no cost to the District, must remove, replace and/or repair as necessary any and all affected portions of the Work.

Name of Contractor

By: _____
Signature of Contractor

Print Name

Title

TOBACCO-FREE WORKPLACE CERTIFICATION

Bid No.: SSPU, #40-04/2020-21

Project: 2021 District-Wide Contract for the Purchase, Lease, Relocate, Dismantling, and Removal of Division of the State (DSA) Approved Portable Buildings

Contractor: _____

The undersigned hereby certifies to the District, subject to penalty for perjury pursuant to the laws of the State of California, that the following is true and correct:

(a) The undersigned is a duly-authorized representative of the Contractor and, in that capacity, has executed this certification on behalf of the Contractor.

(b) In accordance with the Information for Bidders, the Contractor and all sub-contractors shall ensure a tobacco-free workplace by providing the following provision, in writing, to each person providing any labor or services on or at the Project Site, including, without limitation, any delivery personnel:

All properties and facilities operated by the Savanna School District, including, without limitation, the Project Site, are tobacco-free work places. It is strictly forbidden while in, on or at any District property or facility (whether owned or leased) to smoke, chew or otherwise use tobacco products. The Contractor shall require each person (including, without limitation, any employee of the Contractor or any subcontractor or supplier) found in violation of these requirements to permanently leave the Project Site, and the Contractor shall not thereafter permit such person to be present in, on or at the Project Site.

Name of Contractor

By: _____
Signature of Contractor

Print Name

Title

Date

LEAD-CONTAINING MATERIALS NOTICE AND CERTIFICATION

Bid No.: SSPU, #40-04/2020-21

Project: 2021 District-Wide Contract for the Purchase, Lease, Relocate, Dismantling, and Removal of Division of the State (DSA) Approved Portable Buildings

NOTICE TO CONTRACTOR:

In accordance with the Information for Bidders and the Lead Safe Schools Protection Act; California law prohibits, in the construction of any new school facility or in the modernization or renovation of any existing school facility, the use of lead-containing or lead-based paint, plumbing, solders, and other materials that may constitute a potential source of lead contamination.

In the event the Contractor or its employees or subcontractors fail to comply with all applicable laws, rules and regulations related to lead-containing or lead-based paints and other materials, or fail to comply with any other requirements set forth in this Lead-Containing Materials Notice and Certification, the Contractor shall be held solely responsible for any and all costs associated with any investigative and/or corrective actions deemed necessary by the District, and shall indemnify, defend and hold harmless the District, pursuant to the indemnification provisions of the Contract for the Work, with respect to any and all claims, demands, actions, damages, costs, expenses and other liabilities arising therefrom.

CERTIFICATION BY CONTRACTOR:

The undersigned hereby certifies to the District, subject to penalty for perjury pursuant to the laws of the State of California, that the following is true and correct:

- (a) The undersigned is a duly-authorized representative of the Contractor and, in that capacity, has executed this certification on behalf of the Contractor;
- (b) The Contractor is aware and acknowledges that, in circumstances described in this Lead-Containing Materials Notice and Certification, lead-based paint and/or other lead-containing materials may be located on the Project Site;
- (c) The Contractor understands its obligation to comply with all applicable laws, rules and regulations relating to work with, and disposal of, lead-based paint and/or other lead-containing materials; and
- (d) In connection with the performance of the Work, the Contractor shall comply with all applicable laws, rules and regulations relating to work with, and disposal of, lead-based paint and/or other lead-containing materials, as well as the other requirements of this Lead-Containing Materials Notice and Certification.

Name of Contractor

By: _____
Signature of Contractor

Print Name

Title

DISABLED VETERANS BUSINESS ENTERPRISE (DVBE) CERTIFICATION

In accordance with Education Code Section 17076.11, the Savannah School District has a participation goal for Disabled Veteran Business Enterprises of at least three percent (3%) per year of the overall dollar amount of funds allocated by the District by the State Allocation Board pursuant to the Leroy F. Greene School Facilities Act of 1998 for construction or modernization of school buildings and expended each year by the District. At the time of execution of the contract, the Contractor will provide a statement to the District of anticipated participation of Disabled Veteran Business Enterprises in the contract. Note that this form may be used for this initial statement by filling out the statement below. Prior to, and as a condition precedent for final payment under the contract, the Contractor will provide appropriate documentation to the District identifying the amount paid to Disabled Veteran Business Enterprises pursuant to the contract, so that the District can assess its success at meeting this goal.

The Contractor may provide the anticipated participation of Disabled Veteran Business Enterprises in terms of percentage of its total contract or the dollar amount anticipated to be paid to Disabled Veteran Business Enterprises or by providing the names of the Disabled Veteran Business Enterprises that will participate in the contract. If there is a discrepancy between the anticipated goals and the actual goals at completion of the contract or a failure to meet the anticipated goal or dollar amounts, the District will require the Contractor to provide, at the completion of the contract, a detailed statement of the reason(s) for the discrepancy or failure to meet the anticipated goals or dollar amounts.

I certify that I have read the above and will comply with the anticipated participation of Disabled Veteran Business Enterprises in this contract.

At the time of contract execution, the anticipated DVBE participation in the 2021 District-wide Contract for the Purchase, Lease, Relocate, Dismantling, and Removal of Division of the State (DSA) Approved Portable Buildings, SSPU, #40-04/2020-21 is _____% or \$_____.

_____ Signature	_____ Typed or Printed Name
_____ Title	_____ Company
_____ Address	_____ City, State, Zip
_____ Telephone	
_____ E-mail	

**ESCROW AGREEMENT FOR
SECURITY DEPOSITS IN LIEU OF RETENTION**

This Escrow Agreement is made and entered into, as of _____, 20____, by and between Savanna School District, whose address 1330 S. Knott Ave, Anaheim, CA 92804, hereinafter called "DISTRICT;" _____, whose address is _____, hereinafter called "Contractor;" and, _____, whose address is _____, hereinafter called "Escrow Agent."

For the consideration hereinafter set forth, the DISTRICT, Contractor, and Escrow Agent agree as follows:

(1) Pursuant to Section 22300 of the Public Contract Code of the State of California, Contractor has the option to deposit securities with Escrow Agent as a substitute for retention earnings required to be withheld by DISTRICT pursuant to the Agreement entered into between the DISTRICT and Contractor for: 2021 District-Wide Contract for the Purchase, Lease, Relocate, Dismantling, and Removal of Division of the State (DSA) Approved Portable Buildings, Project No. SSPU, #40-04/2020-21 in the amount of _____,

dated _____ (hereinafter referred to as the "Agreement"). Alternatively, on written request of the Contractor, the DISTRICT shall make payments of the retention earnings directly to the Escrow Agent. When the Contractor deposits the securities as a substitute for retention earnings, the Escrow Agent shall notify the DISTRICT within ten (10) days of the deposit. The market value of the securities at the time of the substitution shall be at least equal to the cash amount then required to be withheld as retention under the terms of the Agreement between the DISTRICT and Contractor. Securities shall be held in the name of DISTRICT, and shall designate the Contractor as the beneficial owner.

(2) The DISTRICT shall make progress payments to the Contractor for those funds which otherwise would be withheld from progress payments, provided that the Escrow Agent holds securities in the form and amount specified above.

(3) When the DISTRICT makes payment of retentions earned directly to the Escrow Agent, the Escrow Agent shall hold them for the benefit of the Contractor until the time the escrow created under this Escrow Agreement is terminated. The Contractor may direct the investment of the payments into securities. All terms and conditions of this Escrow Agreement and the rights and responsibilities of the parties shall be equally applicable and binding when the DISTRICT pays the Escrow Agent directly.

(4) Contractor shall be responsible for paying all fees for the expenses incurred by Escrow Agent in administering the Escrow Account and all expenses of the DISTRICT. These expenses and payment terms shall be determined by the DISTRICT, Contractor and Escrow Agent.

(5) The interest earned on the securities or the money market accounts held in escrow and all interest earned on that interest shall be for the sole account of Contractor and shall be subject to withdrawal by Contractor at any time and from time to time without notice to the DISTRICT.

(6) Contractor shall have the right to withdraw all or any part of the principal in the Escrow Account only by written notice to Escrow Agent accompanied by written authorization from the DISTRICT to the Escrow Agent that DISTRICT consents to the withdrawal of the amount sought to be withdrawn by Contractor.

(7) The DISTRICT shall have a right to draw upon the securities in the event of default by the Contractor. Upon seven (7) days' written notice to the Escrow Agent from the DISTRICT of the default, the Escrow Agent shall immediately convert the securities to cash and shall distribute the cash as instructed by the DISTRICT.

(8) Upon receipt of written notification from the DISTRICT certifying that the Agreement is final and complete, and that the Contractor has complied with all requirements and procedures applicable to the Agreement, Escrow Agent shall release to Contractor all securities and interest on deposit less escrow fees and charges of the Escrow Account. The escrow shall be closed immediately upon disbursement of all monies and securities on deposit and payments of fees and charges.

(9) Escrow Agent shall rely on the written notifications from the DISTRICT and the Contractor pursuant to Sections (5) to (8), inclusive, of this Escrow Agreement and the DISTRICT and Contractor shall hold Escrow Agent harmless from Escrow Agent's release and disbursement of the securities and interest as set forth above.

(10) The names of the persons who are authorized to give written notice or to receive written notice on behalf of the DISTRICT and on behalf of Contractor in connection with the foregoing, and exemplars of their respective signatures are as follows:

On Behalf of: SAVANNA SCHOOL DISTRICT: On behalf of Contractor:

Title

Title

Name

Name

Address

Address

Email

Email

Telephone

Telephone

On behalf of Escrow Agent:

Title

Name

Address

Email

Telephone

At the time the Escrow Account is opened, the DISTRICT and Contractor shall deliver to the Escrow Agent a fully executed counterpart of this Escrow Agreement.

IN WITNESS WHEREOF, the parties have executed this Escrow Agreement by their proper officers on the date first set forth above.

SAVANNA SCHOOL DISTRICT

CONTRACTOR

Title

Title

Name

Name

Signature

Signature

Escrow Agent

Title

Name

Signature

TABLE OF CONTENTS TO THE GENERAL CONDITIONS

<u>ARTICLE</u>	<u>PAGE</u>
1. DEFINITIONS.....	1
2. STATUS OF CONTRACTOR.....	2
3. CHANGE IN NAME AND NATURE OF CONTRACTOR'S LEGAL ENTITY.....	2
4. CONTRACTOR'S SUPERVISION, PROSECUTION AND PROGRESS.....	2
5. SUBCONTRACTORS.....	3
6. PROHIBITED INTERESTS.....	4
7. DISTRICT'S INSPECTOR.....	4
8. ARCHITECT'S STATUS.....	5
9. NOTICE OF TAXABLE POSSESSORY INTEREST.....	5
10. ASSIGNMENT OF ANTITRUST ACTIONS.....	5
11. OTHER CONTRACTS.....	6
12. OCCUPANCY.....	6
13. DISTRICT'S RIGHT TO TERMINATE CONTRACT.....	7
14. BONDS.....	9
15. SUBSTITUTION OF SECURITIES.....	9
16. INSURANCE.....	10
17. DRAWINGS AND SPECIFICATIONS.....	13
18. OWNERSHIP OF DRAWINGS.....	14
19. DETAIL DRAWINGS AND INSTRUCTIONS.....	14
20. SHOP DRAWINGS.....	15
21. LAYOUT AND FIELD ENGINEERING.....	17
22. SOILS INVESTIGATION.....	17
23. TESTS AND INSPECTIONS.....	18
24. TRENCHES.....	18
25. DOCUMENTS ON WORK.....	19
26. STATE AUDIT.....	19
27. PREFERENCE FOR MATERIALS AND SUBSTITUTIONS...	19
28. SAMPLES.....	21
29. PROGRESS SCHEDULE.....	21
30. MATERIALS AND WORK.....	22
31. INTEGRATION OF WORK.....	23
32. OBTAINING OF PERMITS, LICNESES AND EASEMENT..	23
33. SURVEYS.....	24
34. EXISTING UTILITY LINES; REMOVAL, RESTORATION.....	24
35. WORK TO COMPLY WITH APPLICABLE LAWS AND REGULATIONS.....	24
36. ACCESS TO WORK.....	24
37. PAYMENTS BY CONTRACTOR.....	25
38. INSPECTORS FIELD OFFICE.....	25
39. UTILITIES.....	25
40. SANITARY FACILITIES.....	25
41. CLEANING UP.....	25

42.	PATENTS, ROYALTIES, INDEMNITIES.....	26
43.	GUARANTEE.....	26
44.	DUTY TO PROVIDE FIT WORKERS.....	27
45.	PREVAILING RATES OF WAGES; RECORDS, APPRENTICES.....	27
46.	HOURS OF WORK.....	28
47.	PAYROLL RECORDS.....	29
48.	NOT USED.....	30
49.	APPRENTICES.....	30
50.	LABOR-FIRST AID.....	31
51.	PROTECTION OF PERSONS AND PROPERTY.....	31
52.	NON-DISCRIMINATION.....	32
53.	SCHEDULE OF VALUES AND PERIODICAL ESTIMATES...	32
54.	CONTRACTOR CLAIMS.....	33
55.	DISPUTES-ARCHITECT'S DECISIONS.....	33
56.	PAYMENTS.....	34
57.	CHANGES AND EXTRA WORK.....	35
58.	COMPLETION.....	39
59.	ADJUSTMENTS TO CONTRACT PRICE.....	40
60.	CORRECTION OF WORK.....	40
61.	EXTENSION OF TIME - LIQUIDATED DAMAGES.....	40
62.	PAYMENTS WITHHELD.....	41
63.	TAXES.....	42
64.	NO ASSIGNMENT.....	42
65.	NOTICE.....	42
66.	NO WAIVER.....	43
67.	NON-UTILIZATION OF ASBESTOS MATERIAL.....	43
68.	LEAD.....	43
69.	CRIMINAL RECORDS CHECK.....	44
70.	<input type="checkbox"/> TOBACCO FREE POLICY.....	44
71.	<input type="checkbox"/> GOVERNING LAW.....	44

GENERAL CONDITIONS

GENERAL CONDITIONS

ARTICLE 1. DEFINITIONS

- (a) Action of the Governing Board is a vote of a majority of the members in a lawful meeting.
- (b) Addenda are the changes in plans, specifications, drawings, and/or Project Documents which have been authorized in writing by the DISTRICT or ARCHITECT, and which alter, explain, or clarify the Project Documents prior to the bid deadline.
- (c) Approval means written authorization by ARCHITECT, DISTRICT, or PROJECT MANAGER.
- (d) Agreement includes collectively all Project Documents.
- (e) Project Documents includes collectively, to wit: Notice Calling for Bids, Information for Bidders, Bid Form-1, Bid Form-2 and all attachments, Bid Security, Designation of Subcontractor form, Information Required of Bidder, Noncollusion Affidavit, Workers' Compensation Certificate, Request for Substitution at Time of Bid, Iran Contracting Act Certificate, Faithful Performance Bond, Payment Bond, Agreement, Escrow Agreement, Drug-Free Workplace Certification, Criminal Records Check Certification, Change Order forms, Contractors Request for Inspection, Request for Information (RFI) Form, Shop Drawing Transmittals form, Disabled Veterans Business Enterprise (DVBE) Certification, Insurance Certificates and Endorsements, Guarantee form, Contractor's Certificate Regarding Non-Asbestos Containing Materials, Tobacco Free Work Place Certification, Lead-Containing Materials Notice and Certification, General Conditions, Supplementary General Conditions, Drawings, Specifications, and all modifications, addenda and amendments thereto. The Project Documents are complementary, and what is called for by any one shall be as binding as if called for by all.
- (f) CONTRACTOR or DISTRICT are those mentioned as such in the Agreement. They are treated throughout the Project Documents as if they are of singular number and neuter gender.
- (g) DISTRICT is the Governing Board or its duly authorized representative.
- (h) Locality in which the work is performed means the county and city in which the work is done.
- (i) Project is the planned undertaking as provided for in the Project Documents by DISTRICT and CONTRACTOR. A project shall be each individual purchase order initiated under this Master Agreement.
- (j) Provide shall include "provide complete in place," that is, "furnish and install."
- (k) Safety Orders are those issued by the Division of Industrial Safety and OSHA safety and health standards for construction.
- (l) Standards, Rules, and Regulations referred to are recognized printed standards and shall be considered as one and a part of these specifications within limits specified.
- (m) Subcontractor, as used herein, includes those having a direct contractual relationship with CONTRACTOR and one who furnishes material worked to a special design according to plans, drawings, and specifications, but does not include one who merely furnishes material not so worked.

- (n) Surety is the person, firm, or corporation that executes as a California admitted surety insurer, the CONTRACTOR's Bid Security, faithful performance bond and payment bond.
- (o) Work of the CONTRACTOR or subcontractor includes labor or materials (including, without limitation, equipment and appliances) or both, incorporated in, or to be incorporated in the Project.
- (p) Workers includes laborer, worker, or mechanic.

ARTICLE 2. STATUS OF CONTRACTOR

- (a) CONTRACTOR is and shall at all times be deemed to be an independent contractor and shall be wholly responsible for the manner in which it performs the services required of it by the terms of the Project Documents. Nothing herein contained shall be construed as creating the relationship of employer and employee, or principal and agent, between the DISTRICT and CONTRACTOR or any of CONTRACTOR's agents or employees. CONTRACTOR assumes exclusively the responsibility for the acts of its employees as they relate to the services to be provided during the course and scope of their employment. CONTRACTOR, its agents and employees shall not be entitled to any rights or privileges of DISTRICT employees and shall not be considered in any manner to be DISTRICT employees. DISTRICT shall be permitted to monitor the activities of the CONTRACTOR to determine compliance with the terms of the Project Documents.
- (b) Contractors are required by law to be licensed and regulated by the Contractors' State License Board. Any CONTRACTOR not so licensed is subject to penalties under the law, and the contract will be considered void pursuant to Section 7028.7 of the Business and Professions Code. Any questions concerning a contractor may be referred to the Registrar, Contractors' State License Board, 9821 Business Park Drive, P. O. Box 26000, Sacramento, CA 95826.
- (c) Pursuant to Labor Code Section 1725.5; Contractors and all sub-contractors are required to be registered with the Department of Industrial Relations (DIR) and participate in their Labor Compliance Monitoring Program.

ARTICLE 3. CHANGE IN NAME AND NATURE OF CONTRACTOR'S LEGAL ENTITY

Before CONTRACTOR makes any change in the name or legal nature of the CONTRACTOR's entity, CONTRACTOR shall first notify the DISTRICT in writing and cooperate with DISTRICT in making such changes as the DISTRICT may request in the Project Documents.

ARTICLE 4. CONTRACTOR'S SUPERVISION, PROSECUTION AND PROGRESS

- (a) During progress of the work, CONTRACTOR shall keep on the work site a competent superintendent satisfactory to DISTRICT. Before commencing the work herein, CONTRACTOR shall give written notice to DISTRICT and ARCHITECT of the name, qualifications and experience of such superintendent. If Superintendent is found unsatisfactory by DISTRICT, CONTRACTOR shall replace the Superintendent with one acceptable to the DISTRICT. Superintendent shall not be changed except with written consent of DISTRICT, unless a superintendent proves to be unsatisfactory to CONTRACTOR and ceases to be in its employ, in which case, CONTRACTOR shall notify DISTRICT and ARCHITECT in writing and replace said Superintendent with one acceptable to the DISTRICT. Superintendent shall represent CONTRACTOR and all directions given to Superintendent shall be as binding as if given to CONTRACTOR.
- (b) CONTRACTOR shall supervise and direct the work competently and efficiently, devoting such attention thereto and applying such skills as may be necessary to perform the work in accordance with the Project Documents. CONTRACTOR shall carefully study and compare all

plans, drawings, specifications, and other instructions and shall at once report to ARCHITECT any error, inconsistency or omission which CONTRACTOR or its employees may discover. The CONTRACTOR represents itself to DISTRICT as a skilled, knowledgeable, and experienced CONTRACTOR. The CONTRACTOR shall carefully study and compare the Project Documents with each other, and shall at once report to the ARCHITECT any errors, inconsistencies, or omissions discovered. The CONTRACTOR shall be liable to the DISTRICT for damage resulting from errors, inconsistencies, or omissions in the Project Documents that the CONTRACTOR recognized and which CONTRACTOR knowingly failed to report and which a similarly skilled, knowledgeable, and experienced contractor would have discovered.

(c) The CONTRACTOR shall verify all indicated dimensions before ordering materials or equipment, or before performing work. The CONTRACTOR shall take field measurements, verify field conditions, and shall carefully compare such field measurements and conditions and other information known to the CONTRACTOR with the Project Documents before commencing work. Errors, inconsistencies or omissions discovered shall be reported to the DISTRICT at once. Upon commencement of any item of work, the CONTRACTOR shall be responsible for dimensions related to such item of work and shall make any corrections necessary to make work properly fit at no additional cost to DISTRICT. This responsibility for verification of dimensions is a non-delegable duty and may not be delegated to subcontractors or agents.

(d) Omissions from the plans, drawings or specifications, or the misdescription of details of work which are manifestly necessary to carry out the intent of the plans, drawings and specifications, or which are customarily performed, shall not relieve the CONTRACTOR from performing such omitted or misdescribed work, but they shall be performed as if fully and correctly set forth and described in the plans, drawings and specifications.

(e) The CONTRACTOR shall be solely responsible for the means, methods, techniques, sequences, and procedures of construction. The CONTRACTOR shall be responsible to see that the finished work complies accurately with the Project Documents.

ARTICLE 5. SUBCONTRACTORS

(a) CONTRACTOR agrees to bind every subcontractor by terms of the Project Documents as far as such terms are applicable to subcontractor's work. If CONTRACTOR shall subcontract any part of the work, CONTRACTOR shall be as fully responsible to DISTRICT for acts and omissions of any subcontractor and of persons either directly or indirectly employed by any subcontractor, as it is for acts and omissions of persons directly employed by CONTRACTOR. Nothing contained in Project Documents shall create any contractual relation between any subcontractor and DISTRICT, nor shall the contract documents be construed to be for the benefit of any subcontractor.

(b) DISTRICT's consent to any subcontractor shall not in any way relieve CONTRACTOR of any obligations under the Project Documents and no such consent shall be deemed to waive any provision of any Project Document.

(c) CONTRACTOR must submit with its bid, a Designation of Subcontractors pursuant to the Subletting and Subcontracting Fair Practices Act. If CONTRACTOR specifies more than one subcontractor for the same portion of work or fails to specify a subcontractor, and such portion of the work exceeds one-half of one percent of the total bid, CONTRACTOR agrees that it is fully qualified to perform and shall perform such work itself, unless CONTRACTOR provides for substitution or addition of subcontractors. Substitution or addition of subcontractors shall be permitted only as authorized under the Subletting and Subcontracting Fair Practices Act, Public Contract Code Section 4100, et. seq.

(d) In accordance with Business and Professions Code Section 7059, if CONTRACTOR is designated as a "specialty contractor" (as defined in Section 7058 of the Public Contract Code), all

of the work to be performed outside of the CONTRACTOR's license specialty shall be performed by a licensed subcontractor in compliance with the Subletting and Subcontracting Fair Practices Act, Public Contract Code Section 4100, et seq.

(e) A copy of each subcontract, if in writing, or, if not in writing, then a written statement signed by the CONTRACTOR giving the name of the subcontractor and the terms and conditions of such subcontract, shall be filed with the DISTRICT before the subcontractor begins work. Each subcontract shall contain a reference to the Agreement between the DISTRICT and the CONTRACTOR and the terms of that Agreement and all parts of the Project Documents shall be made a part of such subcontract insofar as applicable to the work covered thereby. Each subcontract will provide for termination in accordance with Article 13 of these General Conditions. Each subcontract shall provide for its annulment by the CONTRACTOR at the order of the ARCHITECT if in the ARCHITECT'S opinion the subcontractor fails to comply with the requirements of the Project Documents insofar as the same may be applicable to this work. Nothing herein contained shall relieve the CONTRACTOR of any liability or obligation hereunder.

(f) Pursuant to Labor Code Section 1725.5, all sub-contractors shall be registered with the Department of Industrial Relations (DIR) and participate in their Labor Compliance Monitoring program.

ARTICLE 6. PROHIBITED INTERESTS

No official of the DISTRICT who is authorized in such capacity and on behalf of DISTRICT to negotiate, make, accept, or approve, or to take part in negotiating, making, accepting or approving any architectural, engineering, inspection, construction or material supply contract or any subcontract in connection with construction of the Project, shall become directly or indirectly interested financially in this Project or in any part thereof. No officer, employee, architect, attorney, engineer or inspector of or for DISTRICT who is authorized in such capacity and on behalf of DISTRICT to exercise any executive, supervisory or other similar functions in connection with construction of Project shall become directly or indirectly interested financially in this Project or in any part thereof. CONTRACTOR shall receive no compensation and shall repay DISTRICT for any compensation received by CONTRACTOR hereunder, should CONTRACTOR aid, abet or knowingly participate in violation of this Article 6.

ARTICLE 7. DISTRICT'S INSPECTOR

(a) One or more Inspector(s), including special inspectors or in-plant inspectors, as required, will be employed by DISTRICT and will be assigned to the Project.

(b) No work shall be performed by the CONTRACTOR solely upon the instructions or comments by the Inspector. The Inspector has no authority to interpret the Project Documents or order extra work, and any extra work performed without the written instruction of the DISTRICT shall be at CONTRACTOR's sole cost and expense, and there will be no delay damages incurred by DISTRICT for such work.

(c) No work shall be carried on except with the knowledge and under the inspection of said Inspector(s). He/she shall have free access to any or all parts of work at any time. CONTRACTOR shall furnish Inspector reasonable opportunities for obtaining such information as may be necessary to keep Inspector fully informed respecting progress and manner of work and character of materials. Inspection of work shall not relieve CONTRACTOR from any obligation to fulfill the Project Documents. Inspector or ARCHITECT shall have authority to stop work whenever provisions of Project Documents are not being complied with and such noncompliance is discovered. CONTRACTOR shall instruct its employees accordingly.

(d) CONTRACTOR understands and agrees that the Inspector for the Project may also serve concurrently as inspector for other projects and may not therefore be available on site during the entire work day. It shall be the responsibility of CONTRACTOR to notify the Inspector not less than twenty-four (24) hours in advance of materials and equipment deliveries and required inspections.

ARTICLE 8. ARCHITECT'S STATUS

(a) The ARCHITECT shall be the DISTRICT's representative during on-site construction and shall observe the progress and quality of the work on behalf of the DISTRICT. ARCHITECT shall have the authority to act on behalf of DISTRICT only to the extent expressly provided in the Project Documents. ARCHITECT shall have authority to stop work whenever such stoppage may be necessary in ARCHITECT'S reasonable opinion to ensure the proper execution of the Project Documents.

(b) The ARCHITECT shall be, in the first instance, the judge of the performance of the work. ARCHITECT shall exercise authority under the Project Documents to enforce CONTRACTOR's faithful performance.

(c) The ARCHITECT shall have all authority and responsibility established by law. The ARCHITECT has the authority to enforce compliance with the Project Documents and the CONTRACTOR shall promptly comply with instructions from the ARCHITECT or an authorized representative of the ARCHITECT.

(d) On all questions related to the quantities, the acceptability of material, equipment or workmanship, the execution, progress or sequence of work, the interpretation of plans, specifications or drawings, and the acceptable performance of the CONTRACTOR pursuant to the decision of the ARCHITECT shall govern and shall be precedent to any payment unless otherwise ordered by the Governing Board. The progress and completion of the work shall not be impaired or delayed by virtue of any question or dispute arising out of or related to the foregoing matters and the instructions of the ARCHITECT relating thereto.

(e) General supervision and direction of the on-site work by the ARCHITECT shall in no way imply that the ARCHITECT or his or her representatives are in any way responsible for the safety of the CONTRACTOR or its employees or that the ARCHITECT or his or her representatives will maintain supervision over the CONTRACTOR's construction methods or personnel other than to ensure that the quality of the finished work is in accordance with the Project Documents.

ARTICLE 9. NOTICE OF TAXABLE POSSESSORY INTEREST

The terms of the Agreement may result in the creation of a possessory interest. If such a possessory interest is vested in a private party to the Agreement, the private party may be subjected to the payment of property taxes levied on such interest.

ARTICLE 10. ASSIGNMENT OF ANTITRUST ACTIONS

Public Contract Code Section 7103.5 provides:

In entering into a public works contract or a subcontract to supply goods, services, or materials pursuant to a public works contract, the contractor or subcontractor offers and agrees to assign to the awarding body (DISTRICT) all rights, title, and interest in and to all causes of action it may have under Section 4 of the Clayton Act (15 U.S.C. Section 15) or under the Cartwright Act (Chapter 2 (commencing with Section 16700) of Part 2 of Division 7 of the Business and Professions

Code), arising from purchases of goods, services, or materials pursuant to the public works contract or the subcontract. This assignment shall be made and become effective at the time the awarding body tenders final payment to the contractor, without further acknowledgment by the parties.

CONTRACTOR, for itself and all subcontractors, agrees to assign to DISTRICT all rights, title, and interest in and to all such causes of action CONTRACTOR and all subcontractors may have under the Agreement. This assignment shall become effective at the time DISTRICT tenders final payment to the CONTRACTOR, and CONTRACTOR shall require assignments from all subcontractors to comply herewith.

ARTICLE 11. OTHER CONTRACTS

(a) DISTRICT reserves the right to let other contracts in connection with this work. CONTRACTOR shall afford other contractors reasonable opportunity for introduction and storage of their materials and execution of their work and shall properly connect and coordinate its work with such other contractors.

(b) If any part of CONTRACTOR's work depends for proper execution or results upon work of any other contractor, the CONTRACTOR shall inspect and promptly report to ARCHITECT in writing any defects in such work that render it unsuitable for such proper execution and results. CONTRACTOR will be held accountable for damages to DISTRICT for that work which it failed to inspect or should have inspected. CONTRACTOR's failure to inspect and report shall constitute its acceptance of other contractor's work as fit and proper for reception of its work, except as to defects which may develop in other contractors' work after execution of CONTRACTOR's work.

(c) To ensure proper execution of its subsequent work, CONTRACTOR shall measure and inspect work already in place and shall at once report to the ARCHITECT in writing any discrepancy between executed work and Project Documents.

(d) CONTRACTOR shall ascertain to its own satisfaction the scope of the Project and nature of any other contracts that have been or may be awarded by DISTRICT in prosecution of the Project to the end that CONTRACTOR may perform this Agreement in the light of such other contracts, if any.

(e) Nothing herein contained shall be interpreted as granting to CONTRACTOR exclusive occupancy at site of Project. CONTRACTOR shall not cause any unnecessary hindrance or delay to any other contractor working on Project. If simultaneous execution of any contract for Project is likely to cause interference with performance of some other contract or contracts, DISTRICT shall decide which contractor shall cease work temporarily and which contractor shall continue or whether work can be coordinated so that contractors may proceed simultaneously.

(f) DISTRICT shall not be responsible for any damages suffered or extra costs incurred by CONTRACTOR resulting directly or indirectly from award or performance or attempted performance of any other contract or contracts on Project, or caused by any decision or omission of DISTRICT respecting the order of precedence in performance of contracts.

ARTICLE 12. OCCUPANCY

DISTRICT reserves the right to occupy buildings and/or portions of the site at any time before completion, and such occupancy shall not constitute final acceptance of any part of work covered by this Agreement, nor shall such occupancy extend the date specified for completion of the work. Beneficial occupancy of building(s) does not commence any warranty period nor shall it entitle CONTRACTOR to any additional compensation due to such occupancy.

ARTICLE 13. DISTRICT'S RIGHT TO TERMINATE AGREEMENT

(a) Termination for Cause. If the CONTRACTOR refuses or fails to complete the work or any separable part thereof with such diligence as will insure its completion within the time specified or any extension thereof, or fails to complete said work within such time, or if the CONTRACTOR should file a petition for relief as a debtor, or should relief be ordered against CONTRACTOR as a debtor under Title 11 of the United States Code, or if CONTRACTOR should make a general assignment for the benefit of its creditors, or if a receiver should be appointed on account of its insolvency, or if it should refuse or should fail to supply enough properly skilled workers or proper equipment, tools, and materials in the necessary quantity and quality to complete the work in the time specified, or if CONTRACTOR should fail to make prompt payment to subcontractors for materials or labor, or disregard laws or ordinances or instructions of DISTRICT, or if CONTRACTOR or its subcontractors should otherwise be guilty of a violation of any provision of this Agreement, then CONTRACTOR shall be deemed to be in default of the Agreement and DISTRICT may, without prejudice to any other right or remedy, serve written notice upon CONTRACTOR and its surety of DISTRICT's intention to terminate this Agreement, such notice to contain the reasons for such intention to terminate, and unless within ten (10) calendar days after the service of such notice such condition shall cease or such violation shall cease, or arrangements satisfactory to DISTRICT for the correction thereof be made and corrective action commenced in a diligent and workmanlike manner and pursued to satisfactory completion, this Agreement shall upon the expiration of said ten (10) calendar days, cease and terminate. In such case, CONTRACTOR shall be excluded from the worksite and not be entitled to receive any further payment until work is finished to DISTRICT's satisfaction.

(1) In the event of any such termination, surety shall have the right to take over and perform this Agreement, provided, however, that if surety within five (5) calendar days after service upon it of said notice of termination does not give DISTRICT written notice of its intention to take over and perform this Agreement or does not commence performance thereof within ten (10) calendar days after date of serving such notice of termination by DISTRICT on surety, DISTRICT may take over the work and prosecute same to completion by any means determined by DISTRICT including hiring another contractor for the account and at the expense of CONTRACTOR, and CONTRACTOR and its surety shall be liable to DISTRICT for any excess cost or other damages occasioned by the DISTRICT thereby. Time is of the essence in this Agreement. If the DISTRICT takes over the work as hereinabove provided, the DISTRICT may, without liability for so doing, take possession of and utilize in completing the work such materials, supplies, equipment and other property belonging to the CONTRACTOR as may be on the site of the work and necessary therefore.

(2) The expense of finishing the work, including compensation for additional architectural, managerial, and administrative services, shall be a charge against CONTRACTOR and CONTRACTOR agrees that the charge may be deducted from any money due or becoming due to CONTRACTOR from DISTRICT or CONTRACTOR shall pay the charge to the DISTRICT. Expense incurred by DISTRICT as herein provided, and damage incurred through CONTRACTOR's default, shall be certified to DISTRICT by ARCHITECT. The surety shall become liable for payment should CONTRACTOR fail to pay in full any cost incurred by the DISTRICT.

(b) Nonappropriation of Funds/Insufficient Funds. In the event that sufficient funds are not appropriated to complete the Project or the DISTRICT determines that sufficient funds are not available to complete the Project, DISTRICT may terminate or suspend the completion of the Project at any time by giving written notice to the CONTRACTOR. In the event that the DISTRICT exercises this option, the DISTRICT shall pay for any and all work and materials completed or delivered onto the site, and the value of any and all work then in progress and orders actually placed which cannot be canceled up to the date of notice of termination. The value of work and materials paid for shall include a factor of fifteen percent (15%) for the

CONTRACTOR's overhead and profit and there shall be no other costs or expenses paid to CONTRACTOR. All work, materials and orders paid for pursuant to this provision shall become the property of the DISTRICT. DISTRICT may, without cause, order CONTRACTOR in writing to suspend, delay or interrupt the Project in whole or in part for such period of time as DISTRICT may determine. Adjustment shall be made for increases in the cost of performance of the Agreement caused by suspense, delay or interruption.

(c) Termination for Convenience. The District may terminate performance of the Project called for by the Contract Documents in whole or, from time to time, in part, if the District determines that a termination is in the District's interest. The District shall terminate all or any part of the Project upon delivery to the Contractor of a "Notice of Termination" specifying that the termination is for the convenience of the District, the extent of termination, and the effective date of such termination. After receipt of Notice of Termination, and except as directed by the District's Representative, the Contractor shall, regardless of any delay in determining or adjusting any amounts due under this Termination for Convenience clause, immediately proceed with the following obligations:

- (1) Stop Work as specified in the Notice of Termination.
- (2) Complete any work specified in the Notice of Termination in a least cost/shortest time manner while still maintaining the quality called for under the Contract Documents.
- (3) Leave the Property upon which the Contractor was working and upon which the facility (or facilities) forming the basis of the Contract Documents is situated in a safe and sanitary manner such that it does not pose any threat to the public health or safety.
- (4) Terminate all subcontracts to the extent that they relate to the portions of the work terminated.
- (5) Place no further subcontracts or orders, except as necessary to complete the continued portion of the project.
- (6) Submit to the District's Representative, within ten (10) days from the Project termination date found in the Notice of Termination, all of the usual documentation called for by the Contract Documents to substantiate all costs incurred by the Contractor for labor, materials and equipment through the Project termination date, including termination costs related to demobilizing and closing out the project, found in the Notice of Termination. Any documentation substantiating costs incurred by the Contractor solely as a result of the District's exercise of its right to terminate this Contract pursuant to this clause, which costs the Contractor is authorized under the Contract Documents to incur, shall: (i) be submitted to and received by the District no later than thirty (30) days after the Project termination date found in the Notice of Termination; (ii) describe the costs incurred with particularity; and (iii) be conspicuously identified as "Termination Costs occasioned by the District's Termination for Convenience."

(d) Termination of the Contract for convenience shall not relieve the Surety of its obligation for any just claims arising out of or relating to the work performed on the Project.

(e) In the event that the District exercises its right to terminate this Contract for the District's convenience, the District shall pay the Contractor, upon the Contractor's submission of the documentation required by this provision, and other applicable provisions of the Contract Documents the following amounts:

- (1) All actual costs incurred according to the provisions of the Contract Documents including but not limited to insurance costs incurred in connection with the Project.
- (2) A reasonable allowance for profit on the cost of the work on the Project performed, provided Contractor establishes to the satisfaction of the District, that it is reasonably probable that the Contractor would have made a profit had the project been

completed and provided further, that the profit allowed shall in no event exceed five percent (5%) of costs. In no event shall the total amount exceed the original contract cost.

(3) A reasonable allowance for Contractor's administrative costs in determining the amount payable due to termination of the Contract under this Section 57.

(f) The foregoing provisions are in addition to and not a limitation of any other rights or remedies available to the DISTRICT.

ARTICLE 14. BONDS

When specifically included in the scope and cost of a line item quotation for a project, , CONTRACTOR shall furnish a surety bond in an amount equal to one hundred percent (100%) of contract price as security for faithful performance of this Agreement and shall furnish a separate bond in an amount of one hundred percent (100%) of the contract price as security for payment to persons performing labor and furnishing materials in connection with this Project. Bonding shall be considered for all purchase orders issued against the Master Agreement in the amount of \$25,000.00. Bonds shall be in the form set forth in these Project Documents.

ARTICLE 15. SUBSTITUTION OF SECURITIES

(a) Pursuant to the requirements of Public Contract Code Section 22300, upon CONTRACTOR's request, DISTRICT will make payment to CONTRACTOR of any earned retention funds withheld from payments under this Agreement if CONTRACTOR deposits with the DISTRICT or in escrow with a California or federally chartered bank acceptable to DISTRICT, securities eligible for the investment pursuant to Government Code Section 16430 or bank or savings and loan certificates of deposit, upon the following conditions:

(1) CONTRACTOR shall be the beneficial owner of any securities substituted for retention funds withheld and shall receive any interest thereon.

(2) All expenses relating to the substitution of securities under said Section 22300 and under this Article 15, including, but not limited to DISTRICT's overhead and administrative expenses, and expenses of escrow agent shall be the responsibility of the CONTRACTOR.

(3) If CONTRACTOR shall choose to enter into an escrow agreement, such agreement shall be in the form as set forth in Public Contract Code section 22300(f) attached hereto as part of the Project Documents and which shall allow for the conversion to cash to provide funds to meet defaults by the CONTRACTOR including, but not limited to, termination of the CONTRACTOR's control over the work, stop notices filed pursuant to law, assessment of liquidated damages or amount to be kept or retained under the provisions of the Project Documents.

(4) Securities, if any, shall be returned to CONTRACTOR only upon satisfactory completion of the Agreement.

(b) To minimize the expense caused by such substitution of securities, CONTRACTOR shall, prior to or at the time CONTRACTOR requests to substitute security, deposit sufficient security to cover the entire amount to be then withheld and to be withheld under the General Conditions of this Agreement . Should the value of such substituted security at any time fall below the amount for which it was substituted, or any other amount which the DISTRICT determines to withhold, CONTRACTOR shall immediately, and at CONTRACTOR's expense, deposit additional security qualifying under said Section 22300 until the total security deposited is no less than equivalent to the amount subject to withholding under the Agreement.

(c) In the alternative, under Section 22300, CONTRACTOR, at its own expense, may request DISTRICT to make payment of earned retention funds directly to the escrow agent. Also at the expense of CONTRACTOR, CONTRACTOR may direct investment of the payments into securities, and CONTRACTOR shall receive the interest earned on the investment upon the same conditions as shown in paragraph (a) for securities deposited by CONTRACTOR. Upon satisfactory completion of the Agreement, CONTRACTOR shall receive from the escrow agent all securities, interest and payments received by the escrow agent from DISTRICT, pursuant to the terms of Section 22300.

(d) If any provision of this Article 15 shall be found to be illegal or unenforceable, then, notwithstanding, this Article 15 shall remain in full force and effect, and such provision shall be deemed stricken.

ARTICLE 16. INSURANCE: The Contractor shall purchase and maintain, during the performance of all work under this Contract insurance in amounts as specified below:

(a) Commercial General Liability \$1,000,000 per occurrence/\$2,000,000 aggregate for bodily injury, personal injury, and property damage. Coverage for Commercial General Liability insurance shall be at least as broad as the following:

(1) Insurance Services Office Commercial General Liability coverage (Occurrence Form CG 0001)

(2) Commercial General Liability Insurance must include coverage for the following:

(i) Bodily Injury and Property Damage

(ii) Personal Injury/Advertising Injury

(iii) Premises/Operations Liability

(iv) Products/Completed Operations Liability

(v) Aggregate Limits that Apply per Project

(vi) Explosion, Collapse and Underground (UCX) exclusion deleted

(vii) Contractual Liability with respect to this Contract

(viii) Broad Form Property Damage

(ix) Independent Contractors Coverage

(3) All such policies shall name the Savanna School District, the board and each member of the board, its officers, employees, agents (excluding the Architect) and volunteers as Additional Insureds under the policy.

(4) The general liability program may utilize either deductibles or provide coverage excess of a self insured retention, subject to written approval by the District.

(b) Automobile Liability: \$1,000,000 per occurrence for bodily injury and property damage. At all times during the performance of the work under this Contract the Contractor shall maintain Automobile Liability Insurance for bodily injury and property damage including coverage for owned, non owned and hired vehicles, in a form and with insurance companies acceptable to the Savanna School District, including:

(1) Coverage for automobile liability insurance shall be at least as broad as Insurance Services Office Form Number CA 0001 (ed. 6/92) covering automobile liability, Code 1 (any auto).

(2) The automobile liability program may utilize deductibles, but not a self insured retention, subject to written approval by the Savanna School District.

(3) All such policies shall name the Savanna School District, the board and each member of the board, its officers, employees, agents (excluding the Architect) and volunteers as Additional Insureds under the policies.

(c) Workers' Compensation/Employer's Liability: \$1,000,000 per occurrence for employer's liability. Complete and submit the worker's compensation certificate included in the Project Documents upon award of the project. The Contractor shall provide, during the life of this contract, workers' compensation insurance in compliance with applicable statutory requirements and Employer's Liability Coverage for all of his employees engaged in work under this Contract, on or at the site of the project, and, in case any of his work is sublet, the Contractor shall require the subcontractor similarly to provide workers' compensation insurance for all the latter's employees. Any class of employee or employees not covered by a subcontractor's insurance shall be covered by the Contractor's insurance. In case any class of employees engaged in work under this contract, on or at the site of the project, is not protected under the Workers' Compensation Statutes, the Contractor shall provide or shall cause a subcontractor to provide, adequate insurance coverage for the protection of such employees not otherwise protected. The Contractor shall file with the District certificates of his insurance protecting workers. Company or companies providing insurance coverage shall be acceptable to the District, and in the following form and coverage.

(1) Statutory Workers' Compensation and Employer's Liability Coverage: Contractor shall maintain insurance to afford protection for all claims under California Workers' Compensation Act and other employee benefit acts, and in addition, shall maintain Employer's Liability Insurance for a minimum limit of \$1,000,000. The Workers' Compensation Policy shall include the following endorsements, copies of which shall be provided to District:

- i. The Voluntary Compensation Endorsement; and
- ii. Broad Form All States Endorsement; and
- iii. The Longshoremen's and Harbor Workers endorsement, where applicable to the work under this contract; and
- iv. Waiver of Subrogation Endorsement.

(2) If insurance is maintained, the workers' compensation and employer's liability program may utilize either deductibles or provide coverage excess of a self insured retention, subject to written approval by the Savanna School District.

(3) Before beginning work, the Contractor shall furnish to the District satisfactory proof that he/she has taken out for the period covered by the work under this Contract full compensation insurance for all persons employed directly by him/her or through subcontractors in carrying out the work contemplated under this Contract all in accordance with the "Workers' Compensation and Insurance Act," Division IV of the Labor Code of the State of California and any acts amendatory thereof.

(d) Builder's Risk "All Risk" Insurance: Amount of coverage to be negotiated for each individual purchase order initiated under the Master Agreement. When required by the District, Contractor shall include this cost in the line item bid/quotation and shall maintain builder's risk insurance on an "all risk" value basis upon the entire project which is the subject of the Contract. Coverage shall include completed work as well as work in progress. Such insurance shall include the Savanna School District as Loss Payee.

(1) Such insurance may have a deductible clause but not to exceed five thousand dollars, (\$5,000.00) for all risks.

(2) Such policies shall name the Savanna School District as Additional Insured.

(3) The insurer shall waive all rights of subrogation against the Savanna School District and shall provide the District with a Certificate of Insurance for Builder's Risk insurance coverage and evidence of waiver of rights of subrogation against the Savanna School District.

- (e) Evidence Required: Prior to execution of the Contract the Contractor shall file with the District evidence of insurance from an insurer or insurers certifying to the coverage of all insurance required herein. Such evidence shall include original copies of the ISO CG 2010 (ed. 11/85) (or insurer's equivalent) signed by the insurer's representative and Certificate of Insurance (ACORD Form 25 S or equivalent). All evidence of insurance shall be certified by a properly authorized officer, agent or qualified representative of the insurer and shall certify the names of the insured, any additional primary insureds, where appropriate, the type and amount of the insurance, the location and operations to which the insurance applies, and the expiration date of such insurance.
- (f) Policy Provisions Required: All policies shall contain a provision for 30 days advance written notice by the insurer(s) to the District of any cancellation. Statements that the carrier "will endeavor" and "that failure to mail such notice shall impose no obligation and liability upon the company, its agents or representatives," will not be acceptable on certificates. All policies shall contain a provision stating that the Contractor's policies are primary insurance and that the insurance of the Savanna School District or any named insureds shall not be called upon to contribute to any loss.
- (g) Qualifying Insurers: All policies required shall be issued by acceptable insurance companies, as determined by the Savanna School District, which satisfy the following minimum requirements:
- (1) Insurance carriers shall be qualified to do business in California and maintain an agent for process within the state. Such insurance carrier shall have not less than an "A" policyholder's rating and a financial rating of not less than "Class VII" according to the latest Best Key Rating Guide.
- (h) Additional Insurance Provisions:
- (1) The foregoing requirements as to the types and limits of insurance coverage to be maintained by Contractor and any approval of said insurance by the District, is not intended to and shall not in any manner limit or qualify the liabilities and obligations otherwise assumed by the Contractor pursuant to this Contract including but not limited to, the provisions concerning indemnification.
- (2) If at any time during the life of the Contract the Contractor fails to maintain in full force any insurance required by the Contract, including required limits, the District may acquire the necessary insurance for the Contractor and deduct the cost thereof from the appropriate Sublease Payments due the Contractor made by the District.
- (3) If coverage is written on a "claims made" basis, the Certificate of Insurance shall clearly so state. In addition to the coverage requirements specified above, such policy shall provide that:
- i. The policy retroactive date coincides with or precedes Contractor's commencement of work under this Contract (including subsequent policies purchased as renewals or replacements).
- ii. If insurance is terminated for any reason, Contractor shall purchase an extended reporting provision of at least two years to report claims arising in connection with the Contract.
- iii. The policy allows for reporting of circumstances or incidents that might give rise to future claims.
- iv. The District may require the Contractor to provide complete copies of all insurance policies in effect for the duration of the Project.
- v. Neither the District nor the Board, nor any member of the Board, nor any of the directors, officers, employees, agents or volunteers shall be personally responsible for any liability arising under or by virtue of the Contract.

(i) Sub-Contractor Insurance:

- (1) The Contractor must require in its subcontracts applicable to the Work that each subcontractor obtain and maintain insurance coverage in compliance with all of the preceding requirements, except that: (i) no subcontractor need carry a Builder's All-Risk Policy. The Contractor shall be responsible for ensuring that any and all subcontractors have such insurance in effect and for providing all documentation of the subcontractors' insurance coverage (i.e., copies of insurance policies and Certificates of Insurance) to the District within the time(s) required by this article of the General Conditions. The Contractor shall indemnify, defend and hold-harmless the District, with respect to any and all claims, demands, actions, costs, expenses and other liabilities arising from the failure of any subcontractor to have in effect the insurance required.

ARTICLE 17. DRAWINGS AND SPECIFICATIONS

- (a) Portable building drawings are to be prepared and approved by DSA as part of the Contractor's scope, and included in the line item Bid pricing Scope. Site work and utility plans will be prepared and approved through DSA by the District's Architect, under a separate contract with the District.
- (b) Drawings and Specifications are intended to delineate and describe the Project and its component parts to such a degree as will enable skilled and competent contractors to intelligently bid upon the work, and to carry said work to a successful conclusion
- (c) Drawings and Specifications are intended to comply with all laws, ordinances, rules and regulations of constituted authorities having jurisdiction, and where referred to in the Project Documents, said laws, ordinances, rules and regulations shall be considered as a part of the Agreement within the limits specified. The CONTRACTOR shall bear all expenses of correcting work done contrary to said laws, ordinances, rules and regulations and if the CONTRACTOR performed same (1) without first consulting the ARCHITECT for further instructions regarding said work, or (2) disregarded the ARCHITECT'S instructions regarding said work.
- (d) (c) Questions regarding interpretation of drawings and specifications shall be clarified by the ARCHITECT. Before commencing any portion of the work, CONTRACTOR shall carefully examine all drawings and specifications and other information given to CONTRACTOR. CONTRACTOR shall immediately notify ARCHITECT and DISTRICT in writing of any perceived or alleged error, inconsistency, ambiguity, or lack of detail or explanation in the drawings and specifications. If CONTRACTOR or its subcontractors, material or equipment suppliers, or any of their officers, agents, and employees performs, permits, or causes the performance of any work under the Project Documents, which it knows or should have known to be in error, inconsistent, or ambiguous, or not sufficiently detailed or explained, CONTRACTOR shall bear any and all costs arising therefrom including, without limitation, the cost of correction thereof. In the event ARCHITECT determines that CONTRACTOR's requests for clarification or interpretation are not justified or do not reflect adequate competent supervision or knowledge by the CONTRACTOR or his/her subcontractors, CONTRACTOR shall be required to pay ARCHITECT's reasonable and customary fees in processing and responding to such requests. Should the CONTRACTOR commence work or any part thereof without seeking clarification, CONTRACTOR waives any claim for extra work or damages as a result of any ambiguity, conflict or lack of information.
- (e) Figured dimensions on drawings shall govern, but work not dimensioned shall be as directed. Work not particularly shown or specified shall be the same as similar parts that are shown or specified. Large scale drawings shall take precedence over smaller scale

drawings as to shape and details of construction. Specifications shall govern as to materials, workmanship, and installation procedures. Drawings and specifications are intended to be fully cooperative and to agree. If CONTRACTOR observes that drawings and specifications are in conflict, CONTRACTOR shall promptly notify the ARCHITECT in writing, and any necessary changes shall be adjusted as provided in the Article entitled "Changes and Extra Work;" provided, however, that the specification calling for the higher quality material or workmanship shall prevail without additional cost to DISTRICT.

- (f) Materials or work described in words which so applied has a well known technical or trade meaning shall be deemed to refer to such recognized standards.
- (g) It is not the intention of the Agreement to go into detailed descriptions of any materials and/or methods commonly known to the trade under "trade name" or "trade term." The mere mention or notation of such "trade name" or "trade term" shall be considered a sufficient notice to CONTRACTOR that it will be required to complete the work so named with all its incidental and accessory items according to the best practices of the trade.
- (h) The naming of any material and/or equipment shall mean furnishing and installing of same, including all incidental and accessory items thereto and/or labor necessary to achieve full and complete functioning of the material and/or equipment as per best practices of the trade(s) involved, unless specifically noted otherwise.
- (i) ARCHITECT will furnish to CONTRACTOR one (1) complete set of blue-line prints for posting of changes. Additional blue-line prints shall be provided by ARCHITECT upon payment by CONTRACTOR. During the construction period, CONTRACTOR shall maintain the set of blue-line prints in a satisfactory record condition, and shall thoroughly and neatly post, as they occur, all additions, deletions, corrections and/or revisions in the actual construction of the Project. The record drawings must be posted monthly and be current prior to each submission of each certificate of payment.

ARTICLE 18. OWNERSHIP OF DRAWINGS

All plans, drawings, designs, specifications, and other incidental architectural and engineering work or materials and other Project Documents and copies thereof furnished by DISTRICT are DISTRICT'S property. They are not to be used in other work and are to be returned to DISTRICT on request at completion of work, and may be used by DISTRICT as it may require, without any additional costs to DISTRICT.

ARTICLE 19. DETAIL DRAWINGS AND INSTRUCTIONS

- (a) In case of ambiguity, conflict, or lack of information, ARCHITECT shall furnish additional instructions by means of drawings or otherwise, necessary for proper execution of work. All such drawings and instructions shall be consistent with Project Documents, true developments thereof, and reasonably inferable therefrom. Such additional instructions shall be furnished with reasonable promptness, provided that CONTRACTOR informs the ARCHITECT of the relationship of the request to the critical path of construction.
- (b) Work shall be executed in conformity therewith and CONTRACTOR shall do no work without proper drawings and instructions.
- (c) The ARCHITECT will furnish necessary additional details to more fully explain the work, which details shall be considered as part of the Project Documents.

(d) Should any details be more elaborate, in the opinion of the CONTRACTOR, than scale drawings and specifications warrant, CONTRACTOR shall give written notice thereof to the ARCHITECT within five (5) days of the receipt of same. In case no notice is given to the ARCHITECT within five (5) days, it will be assumed the details are reasonable development of the scale drawings. In case notice is given, then it will be considered, and if found justified, the ARCHITECT will either modify the drawings or shall recommend to DISTRICT a change order for the extra work involved.

(e) All parts of the described and shown construction shall be of the best quality of their respective kinds and the CONTRACTOR is hereby advised to use all diligence to become fully involved as to the required construction and finish, and in no case to proceed with the different parts of the work without obtaining first from the ARCHITECT such directions and/or drawings as may be necessary for the proper performance of the work.

(f) If it is found at any time, before or after completion of the work, that the CONTRACTOR has varied from the drawings and/or specifications, in materials, quality, form or finish, or in the amount or value of the materials and labor used, the ARCHITECT shall make a recommendation: (1) that all such improper work should be removed, remade and replaced, and all work disturbed by these changes be made good at the CONTRACTOR's expense; or (2) that the DISTRICT deduct from any amount due CONTRACTOR, the sum of money equivalent to the difference in value between the work performed and that called for by the drawings and specifications. ARCHITECT shall determine such difference in value. The DISTRICT, at its option, may pursue either recommendation made by the ARCHITECT.

ARTICLE 20. SHOP DRAWINGS

(a) CONTRACTOR shall check and verify all field measurements and shall submit to ARCHITECT within fourteen (14) calendar days of the date specified on the Notice to Proceed for each purchase order issued under this Contract three (3) hard copies, and one (1) electronic copy checked and approved by CONTRACTOR, of all shop or setting list drawings, schedules, and materials list required for the work of various trades. ARCHITECT shall review such drawings, schedules and materials list only for conformance with design concept of Project and compliance with information given in Project Documents, and return as approved or disapproved with guidance as to required corrections within fourteen (14) calendar days. CONTRACTOR shall make any corrections required by ARCHITECT, file three (3) corrected copies with ARCHITECT, and furnish such other copies as may be needed for construction within seven (7) calendar days. ARCHITECT'S approval of such drawings, schedules, or materials list shall not relieve CONTRACTOR from responsibility for deviations unless CONTRACTOR has in writing called ARCHITECT'S attention to such deviations at time of submission and secured ARCHITECT'S written approval, nor shall it relieve CONTRACTOR from responsibility for errors in shop drawings or schedules.

(b) All submittals of shop drawings, catalog cuts, data sheets, schedules and material lists shall be complete and shall conform to contract drawings and specifications.

(c) The term "shop drawing" as used herein shall be understood to include, but not be limited to, detail design calculations, fabrication and installation drawings, lists, graphs and operating instructions.

(d) Shop drawings shall be submitted at a time sufficiently early to allow review of same by the Division of State Architect (DSA) if required, and the ARCHITECT, and to accommodate the rate of construction progress required under the Project Documents. CONTRACTOR will be required to pay ARCHITECT's reasonable and customary fees in order to expedite review of shop drawings which are not submitted in a timely fashion.

(e) All shop drawing submittals shall be accompanied by an accurately completed transmittal form using the format bound herein. Any shop drawing submittal not accompanied by such a form, or where all applicable items on the form are not completed, will be returned for resubmittal. The CONTRACTOR may authorize a material or equipment supplier to deal directly with the ARCHITECT with regard to shop drawings, however, ultimate responsibility for the accuracy and completeness of the information contained in the submittal shall remain with the CONTRACTOR.

(f) Normally, a separate transmittal form shall be used for each specific item or class of material or equipment for which a submittal is required. Transmittal of shop drawings on various items using a single transmittal form will be permitted only when the items taken together constitute a manufacturer's "package" or are so functionally related that expediency indicates review of the group or package as a whole. At its option, the CONTRACTOR or Supplier may obtain from the ARCHITECT quantities of the shop drawing transmittal form at reproduction cost.

(g) CONTRACTOR's review and approval of shop drawings shall include the following stamp:

"The CONTRACTOR has reviewed and approved not only the field dimensions but the construction criteria and has also made written notation regarding any information in the shop drawings that does not conform to the Project Documents. This shop drawing has been coordinated with all other shop drawings received to date by CONTRACTOR and this duty of coordination has not been delegated to subcontractors, material suppliers, the ARCHITECT, or the engineers on this project.

Signature of CONTRACTOR"

(h) Within fourteen (14) calendar days after receipt of shop drawings, the ARCHITECT will return one or more prints of each drawing to CONTRACTOR with his or her comments noted thereon. The CONTRACTOR shall make a complete and acceptable submittal to the ARCHITECT by the second submission of drawings. The DISTRICT shall withhold funds due the CONTRACTOR to cover additional costs of the ARCHITECT'S review beyond the second submission and any other costs incurred by DISTRICT.

(i) If prints of the shop drawing are returned to the CONTRACTOR marked "NO EXCEPTIONS TAKEN," formal revision of said drawing will not be required. If prints of the drawing are returned to the CONTRACTOR marked "MAKE CORRECTIONS NOTED," formal resubmittal of said drawings will not be required. If prints of the drawing are returned to the CONTRACTOR marked "REVISE AND RESUBMIT," the CONTRACTOR shall revise said drawing and shall resubmit six (6) copies of the revised drawing to the ARCHITECT. If prints of the drawing are returned to the CONTRACTOR marked "REJECTED RESUBMIT," the CONTRACTOR shall resubmit six (6) new copies of the drawing to the ARCHITECT.

(j) Fabrication of an item shall not be commenced before the ARCHITECT has reviewed the pertinent shop drawings and returned copies to the CONTRACTOR marked with "NO EXCEPTIONS TAKEN," or "MAKE CORRECTIONS NOTED." Revisions indicated on shop drawings shall be considered as changes necessary to meet the requirements of the Project Documents and shall not be taken as the basis of claims for extra work. The review of such drawings by the ARCHITECT will be limited to checking for general agreement with the Project Documents, and shall in no way relieve the CONTRACTOR of responsibility for errors or omissions contained therein, nor shall such review operate to waive or modify any provision contained in the Project Documents. Fabricating dimensions, quantities of material, applicable code requirements, and other contract requirements shall be the CONTRACTOR's responsibility.

(k) No work represented by required shop drawings shall be purchased or commenced until the applicable submittal has been approved. The work shall conform to the approved shop drawings and all other requirements of the Project Documents. The CONTRACTOR shall not proceed with any related work which may be affected by the work covered under shop drawings until the applicable shop drawings have been approved, particularly where piping, machinery, and equipment and the required arrangements and clearances are involved.

(l) Except where the preparation of a shop drawing is dependent upon the approval of a prior shop drawing, all shop drawings pertaining to the same class or portion of the work shall be submitted simultaneously.

(m) Calculations of a structural nature must be approved by the Division of State Architect.

(n) THE CONTRACTOR SHALL HAVE NO CLAIM FOR DAMAGES OR EXTENSION OF TIME DUE TO ANY DELAY RESULTING FROM THE CONTRACTOR HAVING TO MAKE THE REQUIRED REVISIONS TO SHOP DRAWINGS UNLESS REVIEW BY THE ARCHITECT OF SAID DRAWINGS IS DELAYED BEYOND THE TIME PROVIDED HEREINBEFORE AND THE CONTRACTOR CAN ESTABLISH THAT THE ARCHITECT'S DELAY IN REVIEW ACTUALLY RESULTED IN A DELAY IN THE CONTRACTOR CONSTRUCTION SCHEDULE. CONTRACTOR SHALL NOT BE ENTITLED TO ANY CLAIM FOR DAMAGES RESULTING FROM DSA REVIEW EXTENDING BEYOND FIFTEEN (15) CALENDAR DAYS AFTER SUBMITTAL. HOWEVER, DISTRICT MAY CONSIDER AN EXTENSION OF TIME DUE TO ANY DELAY CAUSED BY DSA REVIEW.

ARTICLE 21. LAYOUT AND FIELD ENGINEERING

All field engineering required for laying out of this work and establishing grades for earthwork operations shall be furnished by CONTRACTOR at its expense. Such work shall be done by a qualified and experienced Civil Engineer/Professionally Licensed Surveyor, as approved by the ARCHITECT. Any required "Record" drawings of site development shall be prepared by the approved civil engineer.

ARTICLE 22. SOILS INVESTIGATION REPORT

(a) When a soils investigation report has been obtained from test holes at the site for a specific project, such report will be available for the CONTRACTOR's use in preparing its bid and work under this Agreement. Such report shall not be part of the Agreement. Any information obtained from such report or any information given on drawings as to surface and subsurface soil condition or to elevations of existing grades or elevations of underlying rock is approximate only, is not guaranteed and does not form a part of the Agreement. CONTRACTOR is required to make a visual examination of site and must make whatever test CONTRACTOR deems appropriate to determine surface and subsurface soil conditions. If, during the course of work under this Agreement, CONTRACTOR encounters subsurface or latent conditions which differ materially from those indicated in the soils investigation report, then CONTRACTOR shall notify the DISTRICT within five (5) working days of discovery of the condition.

WARNING: DISTRICT DOES NOT WARRANT THE SOILS AT THE PROJECT SITE NOR ANY INFORMATION CONTAINED IN ANY SOILS REPORT. SOILS INVESTIGATION REPORT IS PROVIDED FOR CONTRACTOR'S INFORMATION ONLY. CONTRACTOR HAS CONDUCTED AN INDEPENDENT INVESTIGATION OF THE PROJECT SITE AND THE SOILS CONDITIONS OF THE SITE. DISTRICT DOES NOT WARRANT THE SOILS CONDITIONS OF THE SITE AND CONTRACTOR IS FULLY RESPONSIBLE TO ASCERTAIN SITE CONDITIONS FOR THE PURPOSES OF DETERMINING CONSTRUCTION MEANS AND METHODS PRIOR TO COMMENCING CONSTRUCTION.

(b) CONTRACTOR agrees that no claim against DISTRICT will be made by CONTRACTOR for damages and hereby waives any rights to damages in the event that during progress of work CONTRACTOR encounters subsurface or latent conditions at the worksite materially different from those shown on drawings or indicated in specifications.

ARTICLE 23. TESTS AND INSPECTIONS

(a) Tests and inspections will comply with California Code of Regulations and with all other laws, ordinances, rules, regulations, or orders of public authorities having jurisdiction over the Project.

(b) If the Agreement, DISTRICT's instructions, laws, ordinances, or any public authority require any work to be specially tested or approved, CONTRACTOR shall give notice in accordance with such authority of its readiness for observation or inspection at least two (2) working days prior to being tested or covered up. If inspection is by authority other than DISTRICT, CONTRACTOR shall inform the DISTRICT's Inspector of the date fixed for such inspection. Required certificates of inspection shall be secured by CONTRACTOR. Observations by DISTRICT's Inspector shall be promptly made, and where practicable, at source of supply. If any work should be covered up without approval or consent of DISTRICT's Inspector, it must be uncovered for examination and satisfactorily reconstructed at CONTRACTOR's expense in compliance with the Agreement. Costs of tests, inspections and any materials found to be not in compliance with the Agreement shall be paid for by CONTRACTOR. Other costs for test and inspection shall be paid by the DISTRICT.

i. Utilize the Inspection Request Form included in the contract documents, for any tests or inspections needed for on-site work.

ARTICLE 24. TRENCHES

(a) CONTRACTOR shall provide adequate sheeting, shoring, and bracing, or equivalent method, for the protection of life and limb in trenches and open excavation which conform to applicable safety standards.

(b) If this Agreement involves the excavation of any trench or trenches five (5) feet or more in depth, and the Project cost is in excess of \$25,000, the CONTRACTOR shall, in advance of excavation, submit to the DISTRICT for acceptance or to whomever DISTRICT designates which may include a registered civil or structural engineer employed by the DISTRICT to whom authority to accept has been delegated, a detailed plan showing the design of shoring, bracing, sloping or other provisions to be made for worker protection from the hazard of caving ground during the excavation of such trench or trenches. If such plan varies from the Shoring System Standards established by the Construction Safety Orders of the Division of Industrial Safety, the plan shall be prepared by a registered civil or structural engineer employed by the CONTRACTOR, and all costs therefore shall be included in the price named in the Agreement for completion of the work as set forth in the Project Documents. In no case shall such plan be less effective than that required by the Construction Safety Orders. No excavation of such trench or trenches shall be commenced until said plan has been accepted by CAL-OSHA and a CAL-OSHA permit for such plan delivered to the DISTRICT. Labor Code Section 6500 and 6705; Health and Safety Code Section 17922.5)

(c) If this Agreement involves the digging of trenches or excavations that extend deeper than four feet below the surface, the following shall apply pursuant to Public Contract Code section 7104:

(1) The CONTRACTOR shall promptly, and before the following conditions are disturbed, notify the DISTRICT, in writing, of any:

(i) Material that the CONTRACTOR believes may be material that is hazardous waste, as defined in Section 25117 of the Health and Safety Code, that is required to be removed to a Class I, Class II, or Class III disposal site in accordance with provisions of existing law.

(ii) Subsurface or latent physical conditions at the site different from those indicated.

(iii) Unknown physical conditions at the site of any unusual nature, different materially from those ordinarily encountered and generally recognized as inherent in work of the character provided for in the contract.

(2) The DISTRICT shall promptly investigate the conditions, and if it finds that the conditions do materially so differ, or do involve hazardous waste, and cause a decrease or increase in the CONTRACTOR's cost of, or the time required for, performance of any part of the work shall issue a change order under the procedures described in the Project Documents.

(3) In the event a dispute arises between the DISTRICT and the CONTRACTOR, whether the conditions materially differ or involve hazardous waste, or cause a decrease or increase in the CONTRACTOR's cost of, or time required for, performance of any part of the work, the CONTRACTOR shall not be excused from any scheduled completion date provided for by the Project Documents, but shall proceed with all the work to be performed under the Project Documents. The CONTRACTOR shall retain any and all rights provided either by contract or by law which pertain to the resolution of disputes and protests between the contracting parties.

ARTICLE 25. DOCUMENTS ON WORK

CONTRACTOR shall keep on the job site at all times one legible copy of all Project Documents, including addenda and change orders, and all approved drawings, plans, schedules and specifications. Said Documents shall be kept in good order and available to ARCHITECT, ARCHITECT's representatives, and all authorities having jurisdiction. CONTRACTOR shall be acquainted with and comply with all California Code of Regulations provisions relating to conditions on this Project.

ARTICLE 26. STATE AUDIT

Pursuant to and in accordance with the provisions of Government Code Section 8546.7, or any amendments thereto, all books, records and files of the DISTRICT, the CONTRACTOR, or any subcontractor connected with the performance of this Agreement involving the expenditure of public funds in excess of Ten Thousand Dollars (\$10,000.00), including, but not limited to, the costs of administration of the Agreement, shall be subject to the examination and audit of the State Auditor at the request of the DISTRICT or as part of any audit of the DISTRICT for a period of three (3) years after final payment is made under this Agreement .

ARTICLE 27. PREFERENCE FOR MATERIALS AND SUBSTITUTIONS

(a) One Product Specified. Unless the Plans and Specifications state that no Substitution is permitted, whenever the Contract Documents indicate any specific article, device, equipment, product, material, fixture, patented process, form, method, construction, or any specific name, make, trade name, or catalog number, with or without the words, "or equal," such specification shall be read as if the language "or equal" is incorporated.

(b) Request for Substitution. As indicated in the Information for Bidders, the bidder may, unless otherwise stated, offer any material, process, article, etc., which is materially equal or better in every respect to that so indicated or specified (“Specified Item”) and will completely accomplish the purpose of the Contract Document. If bidder desires to offer a Substitution for a Specified Item, such bidder must make a request in writing on the District’s Substitution Request Form (“Request Form”) and submit the completed Request Form with the bidder’s bid. The Request Form must be accompanied by evidence as to whether the proposed substitution:

- 1) Is equal in quality, service, and ability to the Specified Item as demonstrated by a side by side comparison of key characteristics and performance criteria (CSI comparison chart);
- 2) Will entail no changes in detail, construction and scheduling of related work;
- 3) Will be acceptable in consideration of the required design and artistic effect;
- 4) Will provide no cost disadvantage to the District;
- 5) Will require no excessive or more expensive maintenance, including adequacy and availability of replacement parts; and
- 6) Will require no change in the Contract Time.

In completing the Request Form, bidder must state with respect to each requested substitution whether bidder will agree to provide the Specified Item in the event that the District denies bidder’s request for substitution of a Specified Item. In the event that bidder does not agree in the Request Form to provide the Specified Item and the District denies the requested Substitution, the bidder’s bid shall be considered non-responsive and the District may award the Contract to the next lowest bidder or in its sole discretion, release all bidders. In the event that bidder has agreed in the Request Form to provide the Specified Item and the District denies bidder’s requested substitution for a Specified Item, bidder shall execute the Agreement and provide the Specified Item without any additional cost or charge to the District, and if bidder fails to execute the Agreement with the Specified Item(s), bidder’s bid bond will be forfeited.

After the bids are opened, the apparent lowest bidder shall provide, within one (1) calendar days of opening such bids, any and all Drawings, Specifications, samples, performance data, calculations, and other information as may be required to assist the Architect and the District in determining whether the proposed substitution is acceptable. The burden of establishing these facts shall be upon the bidder.

After the District’s receipt of such evidence by bidder, the District will make its final decision as to whether the bidder’s request for Substitution for any Specified Items will be granted. The District shall have sole discretion in deciding as to whether a proposed request for Substitution is equal to or better than a Specified Item. Any request for Substitution which is granted by the District shall be documented and processed through a Change Order. The District may condition its approval of any Substitution upon delivery to the District of an extended warranty or other assurances of adequate performance of the Substitution. Any and all risks of delay due to DSA, or any other governmental agency having jurisdiction shall be on the bidder.

(c) In the event CONTRACTOR furnishes material, process, service or equipment other than what was specified by the DISTRICT and which has been accepted by the DISTRICT and which later is defective, then CONTRACTOR at its sole cost and expense shall furnish the DISTRICT specified material, process, service or equipment or fully replace with new the defective material process, service or equipment at DISTRICT’s discretion.

(d) In the event CONTRACTOR furnishes material, process service, or equipment more expensive than that specified, difference in cost of such material, process, service, or equipment so furnished shall be borne by CONTRACTOR. Any engineering, design fees, or approval agencies' fees required to make adjustments in material or work of all trades directly or indirectly affected by the approved substituted items shall be borne entirely by CONTRACTOR. Any difference in cost between an approved substitution which is lower in cost than the originally specified item shall be refunded or credited by CONTRACTOR to DISTRICT.

(e) Price, fitness and quality being equal with regard to supplies, the District may prefer supplies grown, manufactured, or produced in California and next prefer supplies partially manufactured grown, or produced in California provided the bids of said suppliers or the prices quoted by them do not exceed by more than 5% of the lowest bids/prices quoted by out of state suppliers, the major portion of the manufacture of the supplies is not done outside of California and the public good will be served thereby. (Government Code section 4330-4334)

ARTICLE 28. SAMPLES

(a) CONTRACTOR shall furnish for approval, within fourteen (14) calendar days following award of contract, all samples as required in specifications together with catalogs and supporting data required by ARCHITECT. This provision shall not authorize any extension of time for performance of the work. ARCHITECT shall review such samples, as to conformance with design concept of work and for compliance with information given in Project Documents and approve or disapprove same within fourteen (14) working days from receipt of same.

(b) Unless specified otherwise, sampling, preparation of samples and tests shall be in accordance with the latest standards of the American Society for Testing and Materials.

(c) Samples shall, upon demand of ARCHITECT or DISTRICT, be submitted for tests or examinations and considered before incorporation of same into the work. CONTRACTOR shall be solely responsible for delays due to samples not being submitted in time to allow for tests. Acceptance or rejection will be expressed in writing. Work shall be equal to approved samples in every respect. Samples which are of value after testing will remain the property of the CONTRACTOR.

ARTICLE 29. PROGRESS SCHEDULE

(a) Within five (5) calendar days after being awarded the contract, CONTRACTOR shall submit a progress schedule for DISTRICT's approval. The schedule shall indicate the beginning and completion dates of all phases of construction and shall use the "critical path method" (commonly called CPM) or equivalent scheduling methodology for the value reporting, planning and scheduling, of all work required under the Project Documents. The schedule will separately identify those milestones or events that must be completed before other portions of the work can be accomplished.

(b) The scheduling is necessary for the DISTRICT's adequate monitoring of the progress of the work and shall be prepared in accordance with the time frame described in Article 4 of the Agreement. The DISTRICT may disapprove such a schedule and require modification to it if, in the opinion of the ARCHITECT or DISTRICT, adherence to the progress schedule will cause the work not to be completed in accordance with the Agreement. CONTRACTOR shall adhere to any such modifications required by the DISTRICT.

(c) CONTRACTOR will exchange scheduling information with subcontractors and suppliers. CONTRACTOR will order work, equipment and materials with sufficient lead time to avoid interruption of the work.

(d) The CONTRACTOR shall submit to DISTRICT a monthly schedule to reflect the actual sequence of the work which shall be totally separate and apart from the original progress schedule.

(e) The CONTRACTOR shall also, if requested by the ARCHITECT or DISTRICT, provide revised schedules within ten (10) calendar days if, at any time, the ARCHITECT or DISTRICT, consider the completion date to be in jeopardy. The revised schedule shall be designed to show how the CONTRACTOR intends to accomplish the work to meet the original completion date. The form and method employed by the CONTRACTOR shall be the same as for the original progress schedule. The CONTRACTOR shall modify any portions of the schedule that become

infeasible because of "activities behind schedule" or for any other valid reason. CONTRACTOR will provide documents and justification for any schedule changes. An activity that cannot be completed by its original completion date shall be deemed to be behind schedule.

(f) CONTRACTOR shall submit a revised schedule within ten (10) consecutive calendar days of CONTRACTOR's request for any extension of time. Failure to submit such schedule will result in CONTRACTOR waiving his/her right to obtain any extension of time.

(g) IT IS AGREED THAT THE DISTRICT OWNS THE "FLOAT" ON THIS PROJECT. IF CONTRACTOR SUBMITS A REVISED SCHEDULE SHOWING AN EARLIER COMPLETION DATE FOR THE PROJECT, DISTRICT's ACCEPTANCE OF THIS REVISED SCHEDULE SHALL NOT ENTITLE CONTRACTOR TO ANY DELAY CLAIM OR DISRUPTION DAMAGES OR ANY OTHER DAMAGES DUE TO ANY SUCH REVISED SCHEDULE. NOTHING PROVIDED HEREIN SHALL BE CONSTRUED AS A DIRECT, INDIRECT OR IMPLICIT ACCELERATION ORDER TO THE CONTRACTOR.

(h) CONTRACTOR agrees that failure to timely submit the progress schedule, the monthly schedule or any revised progress schedule requested by the ARCHITECT or the DISTRICT may result in delay in payment to CONTRACTOR.

ARTICLE 30. MATERIALS AND WORK

(a) Except as otherwise specifically stated in this Agreement, CONTRACTOR shall provide and pay for all materials, supplies, tools, equipment, labor transportation, superintendence, temporary constructions of every nature, and all other services and facilities of every nature whatsoever necessary to execute and complete the Project within specified time.

(b) Unless otherwise specified, all materials shall be new and the best of their respective kinds and grades as noted or specified, and workmanship shall be of good quality.

(c) Materials shall be furnished in ample quantities and at such times as to insure uninterrupted progress of work and shall be stored properly and protected as required. DISTRICT has no obligation to pay for any prefabricated material stored offsite until delivered and installed to the jobsite and inspected and approved by the inspector of record.

(d) CONTRACTOR shall, after issuance of the Notice to Proceed by DISTRICT, place orders for materials and/or equipment as specified so that delivery of same may be made without delays to the work. CONTRACTOR shall, upon demand from the ARCHITECT, furnish to the ARCHITECT documentary evidence showing that orders have been placed.

(e) DISTRICT reserves the right, for any neglect in not complying with the above instructions, to place orders for such materials and/or equipment as it may deem advisable in order that the work may be completed at the date specified in the Agreement, and all expenses incidental to the procuring of said materials and/or equipment shall be paid for by the CONTRACTOR.

(f) No materials, supplies, or equipment for work under this Agreement shall be purchased subject to any chattel mortgage or under a conditional sale or other agreement by which an interest therein or in any part thereof is retained by seller or supplier. CONTRACTOR warrants good title to all material, supplies, and equipment installed or incorporated in work and agrees upon completion of all work to deliver premises, together with all improvements and appurtenances constructed or placed thereon by it, to DISTRICT free from any claims, liens, or charges. CONTRACTOR further agrees that neither it nor any person, firm, or corporation furnishing any materials or labor for any work covered by this Agreement shall have any right to lien upon premises or any improvement or appurtenance thereon, except that CONTRACTOR may install metering devices or other equipment of utility companies or of political subdivisions, title to which is commonly retained by utility company or political subdivision. In the event of

installation of any such metering device or equipment, CONTRACTOR shall advise DISTRICT as to owner thereof.

(g) Nothing contained in this Article 30, however, shall defeat or impair the rights of persons furnishing material or labor under any bond given by CONTRACTOR for their protection or any rights under any law permitting such persons to look to funds due CONTRACTOR in hand of DISTRICT, and this provision shall be inserted in all subcontracts and material contracts and notice of its provisions shall be given to all persons furnishing materials or labor when no formal contract is entered into for such materials or labor.

(h) The title to new materials and/or equipment and attendant liability for its protection and safety, shall remain in the CONTRACTOR until incorporated in the work and accepted by the DISTRICT; no part of said materials and/or equipment shall be removed from its place of onsite/offsite storage except for immediate installation in the work; and CONTRACTOR shall keep an accurate inventory of all said materials and/or equipment in a manner satisfactory to the DISTRICT or its authorized representative.

ARTICLE 31. INTEGRATION OF WORK

(a) CONTRACTOR shall do all cutting, fitting, patching, and preparation of work as required to make its several parts come together properly, and fit it to receive or be received by work of other contractors or existing conditions showing upon, or reasonably implied by, the drawings and specifications, and shall follow all directions given by the Architect.

(b) All costs caused by defective or ill-timed work shall be borne by CONTRACTOR.

(c) CONTRACTOR shall not endanger any work by cutting, excavating, or otherwise altering work and shall not cut or alter work of any other contractor without the written consent of the ARCHITECT. CONTRACTOR shall be solely responsible for protecting existing work on adjacent properties and shall obtain all required permits for shoring and excavations near property lines.

(d) When modifying existing work or installing new work adjacent to existing work, CONTRACTOR shall match, as closely as conditions of site and materials will allow, the finishes, textures, and colors of the original work, refinishing existing work as required, at no additional cost to DISTRICT.

(e) CONTRACTOR is aware that this Project may be split into several phases. If the Project is split into phases then CONTRACTOR has made allowances for any delays or damages which may arise from coordination with contractors for other phases. If any delays should arise from a contractor working on a different phase, CONTRACTOR's sole remedy for damages, including delay damages, shall be against the contractor who caused such damage and not the DISTRICT. CONTRACTOR shall provide access to contractors for other phases as necessary to prevent delays and damages to contractors working on other phases of construction.

ARTICLE 32. OBTAINING OF PERMITS, LICENSES AND EASEMENTS

(a) Permits, licenses, and certificates necessary for prosecution of work, shall be secured and paid for by CONTRACTOR, unless otherwise specified. All such permits, licenses, and certificates shall be delivered to the ARCHITECT before demand is made for the certificate of final payment. CONTRACTOR shall, and shall require subcontractors to, maintain contractors' licenses in effect as required by law.

(b) Easements for permanent structures or permanent changes in existing facilities shall be secured and paid for by DISTRICT, unless otherwise specified.

(c) Permits and charges for installation, and inspection thereof, of utility services by serving utilities shall be secured and paid for by DISTRICT.

ARTICLE 33. SURVEYS

Surveys to determine location of property lines and corners will be supplied by DISTRICT. Surveys to determine locations of construction, grading, and site work, shall be provided by CONTRACTOR.

ARTICLE 34. EXISTING UTILITY LINES; REMOVAL, RESTORATION

(a) Pursuant to Government Code Section 4215, the DISTRICT assumes the responsibility for removal, relocation, and protection of utilities located on the construction site at the time of commencement of construction under this Agreement with respect to any such utility facilities which are not identified in the plans and specifications. The CONTRACTOR shall not be assessed for liquidated damages for delay in completion of the Project caused by failure of the DISTRICT to provide for removal or relocation of such utility facilities. If the CONTRACTOR, while performing work under this Agreement, discovers utility facilities not identified by the DISTRICT in the plans or specifications, CONTRACTOR shall immediately notify the DISTRICT and the utility in writing. CONTRACTOR shall be compensated according to the provisions governing changes in the work.

(b) This Article 34 shall not be construed to preclude assessment against the CONTRACTOR for any other delays in completion of the work. Nothing in this Article shall be deemed to require the DISTRICT to indicate the presence of existing service laterals or appurtenances whenever the presence of such utilities on the construction site can be inferred from the presence of other visible facilities, such as buildings, meter junction boxes, on or adjacent to the site of the construction.

(c) As part of the work to be performed, CONTRACTOR shall provide the notices and proceed in accordance with Government Code Sections 4216.2, 4216.3 and 4216.4, and pay all fees charged pursuant to Government Code Section 4216, et seq.

ARTICLE 35. WORK TO COMPLY WITH APPLICABLE LAWS AND REGULATIONS

(a) CONTRACTOR shall give all notices and comply with all laws, ordinances, rules, and regulations applicable to the work as indicated and specified.

(b) If CONTRACTOR observes that drawings or specifications are at variance therewith, CONTRACTOR shall promptly notify ARCHITECT in writing and any changes deemed necessary by the ARCHITECT shall be adjusted as provided for changes in work. If CONTRACTOR performs any work which it knew, or through exercise of reasonable care should have known, to be contrary to such laws, ordinances, rules or regulations, and without such notice to ARCHITECT, CONTRACTOR shall bear all costs arising therefrom. Where plans, drawings or specifications state that materials, processes, or procedures must be approved by the Division of State Architect, State Fire Marshall, or other body or agency, CONTRACTOR shall be responsible for satisfying requirements of such bodies or agencies.

ARTICLE 36. ACCESS TO WORK

DISTRICT and its representatives shall at all times have access to work wherever it is in preparation or progress. CONTRACTOR shall provide safe and proper facilities for such access so that DISTRICT's representatives may perform their functions.

ARTICLE 37. PAYMENTS BY CONTRACTOR

CONTRACTOR shall pay:

- (1) For all transportation and utility services not later than the 20th day of the calendar month following that in which such services are rendered;
- (2) For all materials, tools, and other expendable equipment to the extent of ninety percent (95%) of cost thereof, not later than the 20th day of the calendar month following that in which such materials, tools, and equipment are delivered at site of Project and balance of cost thereof not later than the 30th day following completion of that part of work in or on which such materials, tools, and equipment are incorporated or used; and
- (3) To each of its subcontractors, not later than the 5th day following each payment to CONTRACTOR the respective amounts allowed CONTRACTOR on account of work performed by respective subcontractor to the extent of such subcontractor's interest therein.
- (4) Within seven (7) days from the time that all or any portion of the retentions are received by CONTRACTOR from DISTRICT, to each of its subcontractors from whom retention has been withheld, each subcontractor's share of the retention received. However, if a retention payment received by CONTRACTOR is specifically designated for a particular subcontractor, payment of the retention shall be made to the designated subcontractor, if the payment is consistent with the terms of the subcontract. CONTRACTOR may withhold from a subcontractor its portion of the retentions if a bona fide dispute exists between the subcontractor and the CONTRACTOR. The amount withheld from the retention shall not exceed one hundred fifty percent (150%) of the estimated value of the disputed amount.

ARTICLE 38. INSPECTOR'S FIELD OFFICE: Not required.

ARTICLE 39. UTILITIES

- (a) For all utilities, including but not limited to electricity, water, and gas, used on work, the CONTRACTOR may use DISTRICT's existing utilities by making prearranged payments to DISTRICT for utilities used by CONTRACTOR for the Project. Phone and data services must be provided by the Contractor.

ARTICLE 40. SANITARY FACILITIES

The CONTRACTOR shall provide sanitary temporary toilet facilities in no fewer numbers than required by law and such additional facilities as may be directed by the Inspector for the use of all workers. The toilet facilities shall be maintained in a sanitary condition at all times and shall be left at the site until removal is directed by the Inspector. Use of toilet facilities in the work under construction shall not be permitted. When required, this cost will be included as a line item cost in the unit bid.

ARTICLE 41. CLEANING UP

CONTRACTOR at all times shall keep work site free from debris such as waste, rubbish, and excess materials and equipment caused by this work. CONTRACTOR shall not leave debris under, in, or about the work site, but shall promptly remove same. Upon completion of work, CONTRACTOR shall clean interior and exterior of building, including fixtures, equipment, walls, floors, ceilings, roofs, window sills and ledges, horizontal projections, and any areas where debris has collected. CONTRACTOR shall clean and polish all glass, plumbing fixtures, and finish hardware and similar finish surfaces and equipment and remove temporary fencing, barricades,

planking, sanitary facilities and similar temporary facilities from site. If CONTRACTOR fails to clean up, the DISTRICT shall do so and the cost thereof shall be charged to the CONTRACTOR and deducted from any progress payment due.

ARTICLE 42. PATENTS, ROYALTIES, AND INDEMNITIES

The CONTRACTOR shall hold and save the DISTRICT and its governing board, officers, agents, and employees harmless from liability of any nature or kind, including cost and expense, for or on account of any patented or unpatented invention, process, article, or appliance manufactured or used in the performance of this Agreement, including its use by the DISTRICT, unless otherwise specifically provided in the Project Documents, and unless such liability arises from the sole negligence, or active negligence, or willful misconduct of the DISTRICT.

ARTICLE 43. GUARANTEE

(a) CONTRACTOR warrants that the work (which includes any equipment furnished by CONTRACTOR as part of the materials) shall: (a) be free from defects in workmanship and material; (b) be free from defects in any design performed by CONTRACTOR; (c) be new, and conform and perform to the requirements stated in the specifications and where detail requirements are not so stated, shall conform to applicable industry standards; and (d) be suitable for the use stated in the specifications.

(b) The warranty period for discovery of defective work shall commence on the date stamped on the Notice of Completion verifying County recordation and continue for the period set forth in the specifications or for one year if not so specified. If, during the warranty period, the work is not available for use due to defective work, such time of unavailability shall not be counted as part of the warranty period. The warranty period for corrected defective work shall continue for a duration equivalent to the original warranty period.

(c) District shall give CONTRACTOR prompt written notice after discovery of any defective work. CONTRACTOR shall correct any such defective work, as well as any damage to any other part of the work resulting from such defective work, and provide repair, replacement, or reimbursement, at its sole expense, in a manner approved by the DISTRICT and with due diligence and dispatch as required to make the work ready for use by DISTRICT, ordinary wear and tear, unusual abuse or neglect excepted. Such corrections shall include, but not be limited to, any necessary adjustments, modifications, changes of design (unless of DISTRICT's design), removal, repair, replacement or reinstallation, and shall include all necessary parts, materials, tools, equipment, transportation charges and labor as may be necessary, and cost of removal and replacement of work shall be performed at a time and in such a manner so as to minimize the disruption to DISTRICT's use of the work.

(d) In the event of failure of CONTRACTOR or Surety to commence and pursue with diligence said repairs or replacements within ten (10) calendar days after being notified in writing, DISTRICT is hereby authorized to proceed to have defects repaired or replaced and made good at expense of CONTRACTOR and Surety who hereby agree to pay costs and charges therefore immediately on demand.

(e) If, in the opinion of the DISTRICT, defective work creates a dangerous condition or requires immediate correction or attention to prevent further loss to the DISTRICT or to prevent interruption of operations of the DISTRICT, the DISTRICT will attempt to give the written notice required by this Article. If the CONTRACTOR or Surety cannot be contacted or neither complies with the DISTRICT's requirements for correction within a reasonable time as determined by the DISTRICT, the DISTRICT may, notwithstanding the provisions of this Article, proceed to make such correction or provide such attention and the costs of such correction or attention shall be charged against the CONTRACTOR and Surety. Such action by the DISTRICT will not relieve

the CONTRACTOR and Surety of the guarantees provided in this Article or elsewhere in the Project Documents.

(f) This Article does not in any way limit the guarantees on any items for which a longer guarantee is specified or on any items for which a manufacturer gives a guarantee for a longer period. CONTRACTOR shall furnish to DISTRICT all appropriate guarantee or warranty certificates upon completion of the Project or upon request by DISTRICT.

(g) All guarantees required under this Article shall be in writing on the Guarantee form included in the Project Documents.

(h) CONTRACTOR shall provide to DISTRICT instruction manuals for all items which require same.

(i) Nothing herein shall limit any other rights or remedies available to DISTRICT.

(j) The DISTRICT may collect its reasonable costs and attorneys' fees in any action to enforce this Article.

ARTICLE 44. DUTY TO PROVIDE FIT WORKERS

(a) CONTRACTOR and subcontractors shall at all times enforce strict discipline and good order among their employees and shall not employ on work any unfit person or anyone not skilled in work assigned to such person. It shall be the responsibility of CONTRACTOR to ensure compliance with this Article.

(b) Any person in the employ of the CONTRACTOR or subcontractors whom DISTRICT or ARCHITECT may deem incompetent, unfit, troublesome or otherwise undesirable shall be excluded from the work site and shall not again be employed on it except with written consent of DISTRICT.

ARTICLE 45. PREVAILING RATES OF WAGES; RECORDS, APPRENTICES

(a) The Contractor is aware of the requirements of California Labor Code Sections 1720 et seq. and 1770 et seq., as well as California Code of Regulations, Title 8, section 16000 et seq. ("Prevailing Wage Laws") which require the payment of prevailing wage rates and the performance of other requirements on certain "public works" and "maintenance" projects. Since this Master Agreement will involve multiple applicable "public works" or "maintenance" projects, as defined by the Prevailing Wage Laws, and since the total compensation is One Thousand Dollars (\$1,000.00) or more, Contractor agrees to fully comply with such Prevailing Wage Laws. The Contractor shall obtain a copy of the prevailing rates of per diem wages applicable to the work to be performed by subcontractors from the website of the Division of Labor Statistics and Research of the Department of Industrial Relations located at www.dir.ca.gov/dlsr/. Contractor shall make copies of the prevailing rates of per diem wages for each craft, classification or type of worker needed to perform work on the Project available to interested parties upon request, and shall post copies at the Contractor's principal place of business and at the Project site. When determining the bid prices, Contractor shall include to the extent possible anticipated general prevailing wage rates for the time when work on the Project will actually be performed.

(b) Per Senate Bill 854, beginning June 20, 2014, the cost for prevailing wage enforcement was shifted to contractors and subcontractors who must pay required fees to the Department of Industrial Relations (DIR). Effective July 1, 2014, contractors and subcontractors who wish to bid or work on public works projects were required to register with the Department of Industrial Relations and pay the required annual fee. Contractor must also comply with certain minimum requirements to be properly

registered with the Department of Industrial Relations. Effective January 1, 2015, all projects (including this one) were subject to compliance monitoring and enforcement by the Department of Industrial Relations. Effective March 1, 2015, contractor and subcontractors must prove compliance with these new requirements, including appropriate registration with the Department of Industrial Relations. Effective April 1, 2015, no public works contract shall be awarded to a contractor or subcontractor who has not registered with the Department of Industrial Relations, and no contractor or subcontractor shall perform work on a public works project unless the firm is properly registered with the Department of Industrial Relations.

- (c) The Contractor and each subcontractor shall forfeit as a penalty to the District not more than Two Hundred Dollars (\$200.00) for each calendar day, or portion thereof, for each worker paid less than the stipulated prevailing rate for any work done by him, or by any subcontract under him, in violation of the provisions of the California Labor Code. The difference between such stipulated prevailing wage rate and the amount paid to each worker for each calendar day or portion thereof for which each worker was paid less than the stipulated prevailing wage rate shall be paid to each worker by the Contractor.

- (d) As a further material part of this Contract, Contractor agrees to hold harmless and indemnify the District, its Board and each member of the Board, its officers, employees and agents from any and all claims, liability, loss, costs, damages, expenses, fines and penalties, of whatever kind or nature, including all costs of defense and attorneys' fees, arising from any alleged failure of Contractor or its subcontractors to comply with the prevailing wage laws of the State of California. If the District or any of the indemnified parties are named as a party in any dispute arising from the failure of Contractor or its subcontractors to pay prevailing wages, Contractor agrees that the District and the other indemnified parties may appoint their own independent counsel, and Contractor agrees to pay all attorneys' fees and defense costs of the District and the other indemnified parties as billed, in addition to all other damages, fines, penalties and losses incurred by the District and the other indemnified parties as a result of the action.

ARTICLE 46. HOURS OF WORK

- (a) As provided in Article 3, (commencing at Section 1810), Chapter 1, Part 7, Division 2 of the Labor Code, eight (8) hours of labor shall constitute a legal day's work. The time of service of any worker employed at any time by the CONTRACTOR or by any subcontractor on any subcontract under this Agreement upon the work or upon any part of the work contemplated by this Agreement shall be limited and restricted by the Agreement to eight (8) hours per day, and forty (40) hours during any one week, except as hereinafter provided. Notwithstanding the provisions hereinabove set forth, work performed by employees of CONTRACTOR in excess of eight (8) hours per day and forty (40) hours during any one week, shall be permitted upon this public work upon compensation for all hours worked in excess of eight (8) hours per day at not less than one and one-half times the basic rate of pay.

- (b) The CONTRACTOR shall keep and shall cause each subcontractor to keep an accurate record showing the name of and actual hours worked each calendar day and each calendar week by each worker employed by CONTRACTOR in connection with the work or any part of the work contemplated by this Agreement. The record shall be kept open at all reasonable hours to the inspection of the DISTRICT and to the Division of Labor Standards Enforcement, Department of Industrial Relations.

- (c) Pursuant to Labor Code Section 1813, the CONTRACTOR shall pay to the DISTRICT a penalty of Twenty-Five Dollars (\$25) for each worker employed in the execution of this Contract by the CONTRACTOR or by any subcontractor for each calendar day during which such worker

is required or permitted to work more than eight (8) hours in any one calendar day and 40 hours in any one calendar week in violation of the provisions of Article 3 (commencing at Section 1810), Chapter 1, Part 7, Division 2 of the Labor Code.

(d) Any work necessary to be performed after regular working hours, or on Sundays or other holidays shall be performed without additional expense to DISTRICT.

(e) City Ordinance Compliance: The contractor will verify and comply with all City Ordinances regarding noise and work hours. No work shall commence before 7am or continue after 7pm unless expressly permitted by City Ordinance. This includes workers arriving at the work site, and vehicles, or equipment being started, placed, or “warmed up.”

ARTICLE 47. PAYROLL RECORDS

(a) Pursuant to the provisions of Labor Code Section 1776, the CONTRACTOR shall keep and shall cause each subcontractor performing any portion of the work under this Agreement to keep an accurate payroll record, showing the name, address, social security number, work classification, straight time and overtime hours worked each day and week, and the actual per diem wages paid to each journeyman, apprentice, worker, or other employee employed by CONTRACTOR in connection with the work.

(b) The payroll records enumerated under subdivision (a) shall be certified and shall be available for inspection at all reasonable hours at the principal office of the CONTRACTOR on the following basis:

(1) A certified copy of an employee's payroll record shall be made available for inspection or furnished to the employee or his or her authorized representative on request.

(2) A certified copy of all payroll records enumerated in subdivision (a) shall be made available for inspection or furnished, at no cost, upon request to a representative of the DISTRICT, the Division of Labor Standards Enforcement, and the Division of Apprenticeship Standards of the Department of Industrial Relations (DIR). Further, the Contractor will comply with all certified payroll submittal and monitoring processes established as part of the DIR registration program.

(3) A certified copy of all payroll records enumerated in subdivision (a) shall be made available for inspection upon request by the public or copies thereof made; provided, however, that a request by the public shall be made through the District, the Division of Apprenticeship Standards, or the Division of Labor Standards Enforcement. If the requested payroll records have not been provided pursuant to paragraph (2), the requesting party shall, prior to being provided the records, reimburse the costs of preparation by the CONTRACTOR, subcontractors, and the entity through which the request was made. The public shall not be given access to the records at the principal office of the CONTRACTOR.

(4) The form of certification shall be as follows:

I, _____ (Name-print), the undersigned, am (position in business) with the authority to act for and on behalf of _____ (Name of business and/or CONTRACTOR), certify under penalty of perjury that the records or copies thereof submitted and consisting of _____ (description, number of pages) **are in compliance with Labor Code Sections 1771, 1811 and 1815** and are the originals or true, full and correct copies of the originals which depict the payroll record(s) of the actual disbursements by way of cash, check, or whatever form to the individual or individuals named.

Dated: _____ Signature:

(c) The certified payroll records shall be on forms provided by the Division of Labor Standards Enforcement or shall contain the same information as the forms provided by this division.

(d) CONTRACTOR or any subcontractor shall file a certified copy of the payroll records enumerated in subdivision (a) with the entity that requested the records within ten (10) days after receipt of a written request. In the event that the CONTRACTOR or any subcontractor fails to comply within the 10-day period, the CONTRACTOR or subcontractor shall, as a penalty to the DISTRICT, forfeit Twenty-Five Dollars (\$25) for each calendar day, or portion thereof, for each worker, until strict compliance is effectuated. Upon the request of the Division of Apprenticeship Standards or the Division of Labor Standards Enforcement, these penalties shall be withheld from progress payments then due. Labor Code Section 1776(g).

(e) Any copy of payroll records made available for inspection as copies and furnished upon request to the public by the DISTRICT, the Division of Apprenticeship Standards, or the Division of Labor Standards Enforcement shall be marked or obliterated in such a manner as to prevent disclosure of an individual's name, address, and social security number. The name and address of the CONTRACTOR shall not be marked or obliterated.

(f) Copies of payroll records for the prior pay period shall also be submitted to the District with each application for payment. The CONTRACTOR shall inform the DISTRICT of the location of the payroll records enumerated under subdivision (a), including the street address, city and county, and shall, within five (5) working days, provide a written notice of a change of location and address.

(g) It shall be the responsibility of the CONTRACTOR to ensure compliance with the provisions of this Article 47 and the provisions of Labor Code Section 1776.

ARTICLE 48. NOT USED.

ARTICLE 49. APPRENTICES

(a) The CONTRACTOR acknowledges and agrees that, if this Agreement involves a dollar amount greater than or a number of working days greater than that specified in Labor Code Section 1777.5, this Agreement is governed by the provisions of Labor Code Section 1777.5. It shall be the responsibility of the CONTRACTOR to ensure compliance with this Article 49 and with Labor Code Section 1777.5 for all apprenticing occupations.

(b) Apprentices of any crafts or trades may be employed and, when required by Labor Code Section 1777.5, shall be employed provided they are properly registered in full compliance with the provisions of the Labor Code.

(c) Every such apprentice shall be paid the standard wage paid to apprentices under the regulations of the craft or trade at which he or she is employed, and shall be employed only at the work of the craft or trade to which he or she is registered.

(d) Only apprentices, as defined in Section 3077, who are in training under apprenticeship standards and written apprentice agreements under Chapter 4 (commencing at Section 3070), Division 3 of the Labor Code, are eligible to be employed on public works. The employment and training of each apprenticeship shall be in accordance with the provisions of the apprenticeship standards and apprentice agreements under which he or she is training.

(e) Pursuant to Labor Code Section 1777.5, the CONTRACTOR and any subcontractors employing workers in any apprenticeship craft or trade in performing any work under this Agreement shall employ apprentices in at least the ratio set forth in Section 1777.5 and apply to the applicable joint apprenticeship committee for a certificate approving the CONTRACTOR or subcontractor under the applicable apprenticeship standards for the employment and training of apprentices.

(f) Every contractor and subcontractor shall submit contract award information to the applicable joint apprenticeship committee which shall include an estimate of journeyman hours to be performed under the Agreement, the number of apprentices to be employed and the approximate dates the apprentices will be employed.

(g) If the CONTRACTOR or subcontractor willfully fails to comply with Labor Code Section 1777.5, then, upon a determination of noncompliance by the Chief of the Division of Apprenticeship Standards, the CONTRACTOR or subcontractor shall be subject to the penalties imposed under Labor Code Section 1777.7. Interpretation and enforcement of these provisions shall be in accordance with the rules and procedures of the California Apprenticeship Council. (h)

The CONTRACTOR and all subcontractors shall comply with Labor Code Section 1777.6, which section forbids certain discriminatory practices in the employment of apprentices.

(h) CONTRACTOR shall become fully acquainted with the law regarding apprentices prior to commencement of the work. Special attention is directed to Sections 1777.5, 1777.6, and 1777.7 of the Labor Code, and Title 8, California Code of Regulations, Section 200, et seq. Questions may be directed to the State Division of Apprenticeship Standards, 455 Golden Gate Avenue, 8th Floor, San Francisco, California 94102, (415) 703-4920.

ARTICLE 50. LABOR - FIRST AID

The CONTRACTOR shall maintain emergency first aid treatment for CONTRACTOR's workers on the Project which complies with the Federal Occupational Safety and Health Act of 1970 (29 U.S.C.A., Sec. 651, et seq.).

ARTICLE 51. PROTECTION OF PERSONS AND PROPERTY

(a) The CONTRACTOR shall be responsible for all damages to persons or property that occur as a result of its fault or negligence in connection with the prosecution of this Agreement and shall take all necessary measures and be responsible for the proper care and protection of all materials delivered and work performed until completion and final acceptance by the DISTRICT. CONTRACTOR shall provide such heat, covering, and enclosures as are necessary to protect all work, materials, equipment, appliances, and tools against damage by weather conditions. All work shall be solely at the CONTRACTOR's risk with the exception of damage to the work caused by "acts of God" as defined in Public Contract Code Section 7105.

(b) CONTRACTOR shall take, and require subcontractors to take, all necessary precautions for safety of workers and shall comply with all applicable federal, state, local and other safety laws, standards, orders, rules, regulations, and building codes to prevent accidents or injury to persons on, about, or adjacent to the work site and to provide a safe and healthful place of employment. CONTRACTOR shall furnish, erect and properly maintain at all times, as directed by DISTRICT or ARCHITECT or required by conditions and progress of work, all necessary safety devices, safeguards, construction canopies, signs audible devices for protection of the blind, safety rails, belts and nets, barriers, lights, and watchmen for protection of workers and the public and shall post danger signs warning against hazards created by such features in the course of construction. CONTRACTOR shall designate a responsible employee, whose duty shall be to post information regarding protection and obligations of workers and other notices required under occupational safety and health laws, to comply with reporting and other occupational safety requirements, and to protect the life, safety and health of workers. Name and position of person so

designated shall be reported in writing to DISTRICT by CONTRACTOR. CONTRACTOR shall correct any violations of safety laws, standards, orders, rules, or regulations. Upon the issuance of a citation or notice of violation by the Division of Occupational Safety and Health, such violation shall be corrected immediately by the CONTRACTOR at CONTRACTOR's expense.

(c) In an emergency affecting safety of person or of work or of adjoining property, CONTRACTOR, without special instruction or authorization from ARCHITECT or DISTRICT, is hereby permitted to act, at its discretion, to prevent such threatened loss or injury; and CONTRACTOR shall so act if so authorized or instructed by Architect or DISTRICT. Any compensation claimed by CONTRACTOR on account of emergency work shall be determined by written agreement with the DISTRICT.

(d) CONTRACTOR shall take adequate precautions to protect existing roads, sidewalks, curbs, pavements, utilities, adjoining property and structures (including, without limitation, protection from settlement or loss of lateral support), and to avoid damage thereto, and repair any damage thereto caused by construction operations.

(e) CONTRACTOR shall (unless waived by the DISTRICT in writing):

(1) When performing new construction on existing sites, become informed and take into specific account the maturity of the students on the site; perform work which may interfere with school routine before or after school hours; enclose working area with a substantial barricade; not allow any unauthorized individuals on the site; require all workers on the Project to be conspicuously identified either by a firm logo on their clothing or prominent identification badge and arrange work to cause a minimum amount of inconvenience and danger to students and faculty in their regular school activities.

(2) Provide substantial barricades around any shrubs or trees indicated to be preserved.

(3) Deliver materials to building area over route designated by DISTRICT.

(4) When directed by DISTRICT, take preventive measures to eliminate objectionable dust.

(5) Enforce all instructions of DISTRICT and ARCHITECT regarding signs, advertising, fires, and smoking and require that all workers comply with all regulations while on construction site.

(6) Take care to prevent disturbing or covering any survey markers, monuments, or other devices marking property boundaries or corners. If such markers are disturbed by accident, they shall be replaced by an approved civil engineer at no cost to the DISTRICT.

ARTICLE 52. NON-DISCRIMINATION

In the performance of the terms of this Agreement, CONTRACTOR agrees that it will not engage in nor permit such subcontractor as it may employ to engage in unlawful discrimination in employment of persons because of the race, religious creed, color, national origin, ancestry, physical handicap, medical condition, marital status, age or sex of such persons.

ARTICLE 53. SCHEDULE OF VALUES AND PERIODICAL ESTIMATES

(a) For each project initiated under this Master Agreement, the Contractor will produce a line item quote correlated to the scope items listed on Bid Form-2. This will be used as the basis to issue purchase orders for individual projects.

(1) Within ten (10) calendar days of award of contract a detailed schedule of values giving complete breakdown of contract price for each component of the Project or site which shall include all subcontractor/supplier agreements showing dollar amounts of these agreements to justify the schedule of values, and contract price may be used as the schedule of values if agreed upon by both parties.

(2) A periodical itemized estimate of work done for purpose of making partial payments thereon. Change order work shall be clearly identified on a separate schedule of values.

(3) Within ten (10) calendar days of request of DISTRICT, a schedule of estimated monthly payments which shall be due CONTRACTOR under the Agreement.

(b) Values employed in making up any of these schedules are subject to the ARCHITECT's written approval and will be used only for determining basis of partial payments and will not be considered as fixing a basis for additions to or deductions from contract price.

ARTICLE 54. CONTRACTOR CLAIMS

If the CONTRACTOR shall claim compensation for any damage sustained by reason of the acts of the DISTRICT or its agents, CONTRACTOR shall, within five (5) calendar days after sustaining of such damage, make to the ARCHITECT a written statement of the damage sustained. On or before the 15th day of the month succeeding that in which such damage shall have been sustained the CONTRACTOR shall file with the DISTRICT an itemized statement of the details and amount of such damage, and unless such statement shall be made as thus required, CONTRACTOR's claims for compensation shall be forfeited and invalidated and it shall not be entitled to consideration for payment on account of any such damage.

ARTICLE 55. DISPUTES - ARCHITECT'S DECISIONS

(a) The ARCHITECT shall, within a reasonable time, make decisions on all matters relating to the CONTRACTOR's execution and progress of the work. The decisions of the ARCHITECT shall not be binding, but shall be advisory only on the CONTRACTOR for the purpose of CONTRACTOR's obligation to proceed with the work.

(b) Except for tort claims, all claims by the CONTRACTOR for a time extension, payment of money or damages arising from work done by, or on behalf of, the CONTRACTOR pursuant to the Agreement and payment of which is not otherwise expressly provided for or the claimant is not otherwise entitled to, or as to the amount of payment which is disputed by the DISTRICT of Three Hundred Seventy Five Thousand Dollars (\$375,000) or less shall be subject to the settlement procedures set forth in Public Contract Code Section 20104, et seq. which provisions are incorporated herein by reference.

(c) In the event of a dispute between the parties as to performance of the work, the interpretation of this Agreement or payment or nonpayment for work performed or not performed, the parties shall attempt to resolve the dispute. Pending resolution of the dispute, CONTRACTOR agrees to continue the work diligently to completion. If the dispute is not resolved, CONTRACTOR agrees it will neither rescind the Agreement nor stop the progress of the work, but CONTRACTOR's sole remedy shall be to submit such controversy to determination by a court of the State of California, in Orange County, having competent jurisdiction of the dispute, after the Project has been completed, and not before.

ARTICLE 56. PAYMENTS

(a) CONTRACTOR shall utilize form AIA G702, as the cover sheet for ALL APPLICATIONS FOR PAYMENT ON THIS PROJECT. AIA form G703 "Continuation Sheet," will be used as a billing back-up sheet and in calculating progress payments.

(b) Unless otherwise specified in writing, each month within thirty (30) days after receipt by the DISTRICT of the monthly progress schedule and an undisputed, properly submitted payment request from CONTRACTOR which has been certified for payment by the Inspector and the Architect, there shall be paid to CONTRACTOR a sum equal to ninety percent (95%) of value of work performed and of materials delivered to the jobsite and inspected and approved by the inspector of record and subject to or under the control of the DISTRICT and unused up to the last day of the previous month, less aggregate previous payments. Public Contract Code Section 20104.50 Monthly payments shall be made only on the basis of monthly estimates which shall be prepared by CONTRACTOR on a form approved by DISTRICT and filed before the fifth day of the month during which payment is to be made. Work completed as estimated shall be an estimate only and no inaccuracy or error in said estimate shall operate to release CONTRACTOR or Surety from any damages arising from such work or from enforcing each and every provision of this Agreement, and DISTRICT shall have the right subsequently to correct any error made in any estimate for payment. CONTRACTOR SHALL NOT BE ENTITLED TO HAVE ANY PAYMENT ESTIMATES PROCESSED OR BE ENTITLED TO HAVE ANY PAYMENT FOR WORK PERFORMED SO LONG AS ANY LAWFUL OR PROPER DIRECTION CONCERNING WORK, OR ANY PORTION THEREOF, GIVEN BY THE DISTRICT OR ARCHITECT SHALL REMAIN UNCOMPLIED WITH BY THE CONTRACTOR. CONTRACTOR AGREES TO THE FIVE PERCENT (5%) RETENTION ON ALL PROGRESS PAYMENTS. Public Contract Code Section 9203.

(c) DISTRICT has discretion to require from the CONTRACTOR any of the following information with the application for payment: (i) certified payroll covering the period of the prior application for payment; (ii) unconditional waivers and releases from all subcontractors/suppliers for which payment was requested under the prior application for payment; and/or (iii) receipts or bills of sale for any items. CONTRACTOR agrees that payment may be contingent upon District receiving any one or more of these documents.

(d) Before payment is made hereunder, a certificate in writing shall be obtained from the ARCHITECT stating that the work for which the payment is demanded has been performed in accordance with the terms of the Project Documents and that the amount stated in the certificate is due under the terms of the Project Documents, which certificate shall be attached to and made a part of the claim made and filed with the DISTRICT, provided that if the ARCHITECT shall, within three (3) days after written demand therefore, fail to deliver such certificate to the DISTRICT, the CONTRACTOR may file its claim with the DISTRICT without said certificate, but together with such claim shall be filed a statement that demand was made for such certificate and that the same was refused. Thereupon, the DISTRICT will either allow said claim as presented or shall, by an order entered on the minutes of said DISTRICT state the reasons for refusing to allow said claim. It is understood, moreover, that the certificate of the ARCHITECT shall not be conclusive upon the DISTRICT, but advisory only.

(e) Upon receipt of CONTRACTOR's payment request, DISTRICT shall review the payment request as soon as practicable after receipt for the purpose of determining that the payment request is proper. Any payment request determined not to be proper shall be returned to the CONTRACTOR as soon as practicable but not later than seven (7) days after receipt and shall be accompanied by a document setting forth in writing the reasons(s) why the payment request was not proper. Public Contract Code Section 20104.50

(f) NO PAYMENT BY DISTRICT HEREUNDER SHALL BE INTERPRETED SO AS TO IMPLY THAT DISTRICT HAS INSPECTED, APPROVED, OR ACCEPTED ANY PART OF THE WORK.

(g) Unless otherwise provided, on or before making request for final payment of the undisputed amount due under the Agreement, CONTRACTOR shall submit to DISTRICT, in writing a summary of all claims for compensation under or arising out of this Agreement which were timely filed. The acceptance by CONTRACTOR of the payment of the final amount shall constitute a waiver of all claims against DISTRICT under or arising out of this Agreement, except those previously made, in a timely manner and in writing, and identified by CONTRACTOR as unsettled at the time of CONTRACTOR's final request for payment.

(h) CONTRACTOR shall pay each of its subcontractors from whom retention has been withheld each subcontractor's share of the retention received within seven (7) days from the time that all or any portion of the retention are received by the CONTRACTOR subject to any limitations set forth in Public Contract Code Section 7107(e).

(i) The final payment of the five percent (5%) retention of the value of the work done under this Agreement, if unencumbered, shall be made thirty-five (35) days after recording by the DISTRICT of the Notice of Completion at the County Recorder's Office. APPROVAL OF COMPLETION OF THE PROJECT WILL BE MADE ONLY BY ACTION OF THE GOVERNING BOARD OF DISTRICT. Public Contract Code Section 7107.

ARTICLE 57. CHANGES AND EXTRA WORK

(a) DISTRICT may, as provided by law and without affecting the validity of this Agreement, order changes, modifications, deletions and extra work by issuance of written change orders from time to time during the progress of the Project, contract sum being adjusted accordingly. All such work shall be executed under conditions of the original Agreement except that any extension of time caused thereby shall be adjusted at time of ordering such change. DISTRICT has discretion to order changes on a "time and material" basis with adjustments to time made after CONTRACTOR has justified through documentation the impact on the critical path of the Project.

(b) Notwithstanding any other provision in the Project Documents, the adjustment in the contract sum, if any, and the adjustment in the contract time, if any, set out in a change order shall constitute the entire compensation and/or adjustment in the contract time due CONTRACTOR arising out of the change in the work covered by the change order unless otherwise provided in the change order. The amount of the compensation due CONTRACTOR shall be calculated pursuant to subparagraph (e) of this Article 57. The entire compensation shall not include any additional charges not set forth in subparagraph (e) and shall not include delay damages (due to processing of a change order, refusal to sign a change order) indirect, consequential, and incidental costs including any project management costs, extended home office and field office overhead, administrative costs and profit other than those amounts authorized under subparagraph (e) of this Article 57.

(c) In giving instructions, ARCHITECT shall have authority to make minor changes in work, not involving change in cost, and not inconsistent with purposes of the Project. The DISTRICT's Assistant Superintendent of Business Services may authorize changes in work involving a change in cost that does not exceed Fifteen Thousand Dollars \$15,000. Otherwise, except in an emergency endangering life or property, no extra work or change shall be made unless in pursuance of a written order from DISTRICT, authorized by action of the governing board, and no claim for addition to contract sum shall be valid unless so ordered.

(d) If the ARCHITECT determines that work required to be done constitutes extra work outside the scope of the Agreement, the ARCHITECT shall send a request for a detailed proposal to the CONTRACTOR. CONTRACTOR will respond with a detailed proposal within five (5)

calendar days of receipt of the Request for Proposal which shall include a complete itemized cost breakdown of all labor and materials showing actual quantities, hours, unit prices, and the wage rates required for the change. If the change order involves a change in construction time, a request for the time change shall accompany the change order cost breakdown. All such requests for time shall be specified by CONTRACTOR as either "work days" or "calendar days." Any request for time received with only the designation of "days" shall be considered calendar days. The term "work days" as used in this paragraph shall mean Monday through Friday, excluding Saturdays, Sundays and federal/State of California observed holidays. If the work is to be performed by a subcontractor, CONTRACTOR must include a bid from the subcontractor containing the same detailed information as required for CONTRACTOR. No extensions of time will be granted for change orders that, in the opinion of the ARCHITECT, do not affect the critical path of the Project.

(e) Value of any such extra work, change, or deduction shall be determined at the discretion of DISTRICT in one or more of the following ways:

(1) By mutual written acceptance of a lump sum proposal from CONTRACTOR properly itemized and supported by sufficient substantiating data to permit evaluation by DISTRICT and ARCHITECT.

(2) By unit prices contained in CONTRACTOR's original bid and incorporated in the Project Documents or fixed by subsequent agreement between DISTRICT and CONTRACTOR.

(3) By cost of material and labor and percentage for overhead and profit ("time and material"). If the value is determined by this method the following requirements shall apply:

(A) Daily Reports by Contractor.

(i) General. At the close of each working day, the CONTRACTOR shall submit a daily report to the ARCHITECT and the Inspector, on forms approved by the DISTRICT, together with applicable delivery tickets, listing all labor, materials, and equipment involved for that day, and for other services and expenditures when authorized concerning extra work items. An attempt shall be made to reconcile the report daily, and it shall be signed by the ARCHITECT and the CONTRACTOR. In the event of disagreement, pertinent notes shall be entered by each party to explain points which cannot be resolved immediately. Each party shall retain a signed copy of the report. Reports by Subcontractors or others shall be submitted through the CONTRACTOR.

(ii) Labor. The report shall show names of workers, classifications, and hours worked and hourly rate. Project Superintendent expenses are not allowed.

(iii) Materials. The report shall describe and list quantities of materials used and unit cost.

(iv) Equipment. The report shall show type of equipment, size, identification number, and hours of operation, including loading and transportation, if applicable, and hourly/daily cost.

(v) Other Services and Expenditures. Other services and expenditures shall be described in such detail as the DISTRICT may require.

(B) Basis for Establishing Costs

(i) Labor. The costs of labor will be the actual cost for wages prevailing locally for each craft classification or type of workers at the time the extra work is done, plus employer payments of payroll taxes and insurance, health and welfare, pension, vacation, apprenticeship funds, and other direct costs resulting from federal, state or local laws, as well as assessments or benefits required by lawful collective bargaining agreements. The use of labor classification which would increase the extra work cost will not be permitted unless the CONTRACTOR establishes the necessity for such additional costs. Labor costs for equipment operators and helpers shall be reported only when such costs are not included in the invoice for equipment rental.

(ii) Materials. The cost of materials reported shall be at invoice or lowest current price at which such materials are locally available and delivered to the work site in the quantities involved, plus sales tax, freight and delivery. The DISTRICT reserves the right to approve materials and sources of supply, or to supply materials to the CONTRACTOR if necessary for the progress of the work. No markup shall be applied to any material provided by the DISTRICT.

(iii) Tool and Equipment Rental. No payment will be made for the use of tools which have a replacement value of \$100 or less or where an invoice is not provided.

Regardless of ownership, the rates to be used in determining equipment rental costs shall not exceed listed rates prevailing locally at equipment rental source, or distributors, at the time the work is performed. The rental rates paid shall include the cost of fuel, oil, lubrication, supplies, small tools, necessary attachments, repairs and maintenance of any kind, depreciation, storage, insurance, and all incidentals. Necessary loading and transportation costs for equipment used on the extra work shall be included.

If equipment is used intermittently and, when not in use, could be returned to its rental source at less expense to the DISTRICT than holding it at the work site, it shall be returned, unless the CONTRACTOR elects to keep it at the work site at no expense to the DISTRICT.

All equipment shall be acceptable to the ARCHITECT, in good working condition, and suitable for the purpose for which it is to be used. Manufacturer's ratings and manufacturer's approved modifications shall be used to classify equipment and it shall be powered by a unit of at least the minimum rating recommended by the manufacturer.

(iv) Other Items. The DISTRICT may authorize other items which may be required on the extra work. Such items include labor, services, material and equipment which are different in their nature from those required by the work and which are of a type not ordinarily available from the CONTRACTOR or any of the subcontractors. Invoices covering all such items in detail shall be submitted with the request for payment.

(v) Invoices. Vendors' invoices for material, equipment rental, and other expenditures, shall be submitted with the request for payment. If the request for payment is not substantiated by invoices or other documentation, the DISTRICT may establish the cost of the item involved at the lowest price which was current at the time of the report.

(C) The following form shall be used as applicable by the DISTRICT and CONTRACTOR to communicate proposed additions and deductions to the Agreement.

EXTRA CREDIT

- i. Material/Equipment (attach itemized quantity and unit cost plus sales tax) _____

- ii. Labor (attach itemized hours and rates) _____

- iii. Subtotal _____

- iv. If subcontractor performed work, add Subcontractor's overhead and profit to portions performed by it, not to exceed 15% of Item iii. above _____

- v. Subtotal _____

- vi. General Contractor's Overhead and Profit, not to exceed 15% of Item v if Contractor performed the work. If subcontractor performed the work, not to exceed 5% of Item v. Of portions performed by Contractor and subcontractors, portions performed by Contractor shall not exceed 15% of Item V, and portions performed by Subcontractor shall not exceed 5% of Item v. _____

- vii. Subtotal _____

- viii. Bond and Liability Insurance Premium, if in fact additional bonds or insurance were actually purchased, not to exceed 1% of Item vii. _____

- ix. Total _____

(4) IT IS EXPRESSLY UNDERSTOOD THAT THE VALUE OF SUCH EXTRA WORK OR CHANGES, AS DETERMINED BY ANY OF THE AFOREMENTIONED METHODS, EXPRESSLY INCLUDES ANY AND ALL OF CONTRACTOR'S COSTS AND EXPENSES, BOTH DIRECT AND INDIRECT, RESULTING FROM ADDITIONAL TIME REQUIRED ON THE PROJECT, OR RESULTING FROM DELAYS TO THE PROJECT. ANY COSTS OR EXPENSES NOT INCLUDED ARE DEEMED WAIVED. FOR PURPOSES OF DETERMINING THE COST, IF ANY, OF ANY EXTRA WORK, CHANGE, ADDITION OR OMISSION HEREUNDER, ALL TRADE DISCOUNTS, REBATES, REFUNDS, AND ALL RETURNS FROM THE SALE OF SURPLUS MATERIALS AND EQUIPMENT SHALL ACCRUE AND BE CREDITED TO CONTRACTOR, AND CONTRACTOR SHALL ENSURE THAT SUCH DISCOUNTS, REBATES, REFUNDS, AND RETURNS MAY BE SECURED,

AND THE AMOUNT THEREOF SHALL BE ALLOWED AS A REDUCTION OF CONTRACTOR'S COST IN DETERMINING THE ACTUAL COST OF CONSTRUCTION FOR PURPOSES OF ANY EXTRA WORK, CHANGE, ADDITION OR OMISSIONS IN THE WORK AS PROVIDED HEREIN.

(f) If the CONTRACTOR should claim that any instruction, request, drawing, specification, action, condition, omission, default, or other situation obligates the DISTRICT to pay additional compensation to CONTRACTOR or to grant an extension of time, or constitutes a waiver of any provision in the Agreement, CONTRACTOR shall notify the DISTRICT, in writing, of such claim within five (5) calendar days from the date CONTRACTOR has actual or constructive notice of the factual basis supporting the claim. The notice shall state the factual bases for the claim and cite in detail the Project Documents (including plans and specifications) upon which the claim is based. The CONTRACTOR's failure to notify the DISTRICT within such five (5) day period shall be deemed a waiver and relinquishment of such a claim. If such notice be given within the specified time, the procedure for its consideration shall be as stated above in these General Conditions.

(g) “PROHIBITED USAGE OF CONTRACTOR QUALIFYING LANGUAGE STAMPS ON DISTRICT DRAWINGS OR CONTRACT FORMS.” Contractor shall not countersign or endorse any form, drawing, change order, contract or other documents with any conditions not mutually agreed to in advance by the DISTRICT and the CONTRACTOR. Endorsement of a contract, change order, specification, drawing or form with the following: “This change order is being executed without waiver of the right to seek additional compensation for such services,” shall be of no legal force or effect.

ARTICLE 58. COMPLETION

(a) The DISTRICT shall accept completion of the Project and have the Notice of Completion recorded with the County within ten (10) days of acceptance of completion of the Project when the entire work, including punch list items, shall have been completed to the satisfaction of the DISTRICT. Civil Code Section 3093. The work may only be accepted as complete by action of the DISTRICT's Governing Board.

(b) However, the DISTRICT, at its sole option, may accept completion of the Project and have the Notice of Completion recorded when the entire work including individual portions of the work shall have been completed to the satisfaction of the DISTRICT, except for minor corrective items, as distinguished from incomplete items.

(c) A final walk through of the Project to determine completion and to record the Notice of Completion shall occur only upon a valid claim by CONTRACTOR that the Project is complete except for minor corrective items. Any erroneous claims of completion by CONTRACTOR resulting in a premature walk through shall be at CONTRACTOR's sole cost and expense and DISTRICT shall make adjustments to the contract price by reducing the amount thereof to pay for any costs incurred by the DISTRICT due to the erroneous claims by the CONTRACTOR that the Project is complete. Minor corrective items shall be identified in the final walk through of the Project.

(d) If the CONTRACTOR fails to complete the minor corrective items prior to the expiration of the thirty-five (35) day period immediately following recording of the Notice of Completion, the DISTRICT shall withhold from the final payment an amount equal to one hundred fifty percent (150%), as determined by the DISTRICT, of the amount of each item until such time as the item is completed. Public Contract Code Section 7107. At the end of such 35-day period, if there are items remaining to be corrected, the DISTRICT may elect to proceed as provided in Article 59 (b) entitled "Adjustments to Contract Price."

ARTICLE 59. ADJUSTMENTS TO CONTRACT PRICE

- (a) If CONTRACTOR defaults or neglects to carry out the work in accordance with the Project Documents or fails to perform any provision thereof, DISTRICT may, after ten (10) days written notice to the CONTRACTOR and without prejudice to any other remedy it may have, make good such deficiencies.
- (b) The DISTRICT shall adjust the total contract price by reducing the amount thereof by the cost of making good such deficiencies. If DISTRICT deems it inexpedient to correct work not done in accordance with the Project Documents, an equitable reduction in the contract price shall be made therefore.

ARTICLE 60. CORRECTION OF WORK

- (a) CONTRACTOR shall promptly remove all work identified by DISTRICT as failing to conform to the Project Documents, whether incorporated or not. CONTRACTOR shall promptly replace and re-execute its own work to comply with Project Documents without additional expense to DISTRICT and shall bear the expense of making good all work of other contractors destroyed or damaged by such removal or replacement.
- (b) If CONTRACTOR does not remove such work within a reasonable time, fixed by written notice, DISTRICT may remove it and may store the material at CONTRACTOR's expense. If CONTRACTOR does not pay expenses of such removal within ten (10) days' time thereafter, DISTRICT may, upon ten (10) days written notice, sell such materials at auction or at private sale and shall account for net proceeds thereof, after deducting all costs and expenses that should have been borne by CONTRACTOR.

ARTICLE 61. EXTENSION OF TIME - LIQUIDATED DAMAGES

- (a) The CONTRACTOR and DISTRICT hereby agree that the exact amount of damages for failure to complete the work within the time specified (for each individual purchase order initiated against this Master Agreement) is extremely difficult or impossible to determine. CONTRACTOR shall be assessed liquidated damages for each and every day the work (for each individual purchase order initiated against this Master Agreement) required under the Project Documents remains unfinished past the time for completion, as set forth in the Agreement, and any extensions of time granted by the DISTRICT to the CONTRACTOR under the terms of the Project Documents. The CONTRACTOR will pay to the DISTRICT or DISTRICT may retain from amounts otherwise payable to the CONTRACTOR, said amount for each day after failure to meet the requirements of the contract completion as scheduled in the Agreement. Government Code Section 53069.85 For purposes of this article, the work shall be considered "complete" in accordance with the provisions of Article 58, "COMPLETION", except that the work may be considered complete without formal acceptance by the DISTRICT Governing Board so long as the Governing Board, at its next regularly scheduled meeting, accepts the work.
- (b) CONTRACTOR shall not be charged for liquidated damages, as set forth above, because of any delays in completion of work which are not the fault or negligence of CONTRACTOR, including but not restricted to acts of God. CONTRACTOR shall within ten (10) days of beginning of any such delay, notify DISTRICT in writing of causes of delay. CONTRACTOR shall provide documentation and justification to substantiate the delay and its relation to the Project's critical path. DISTRICT shall ascertain the facts and extent of delay and grant extension of time for completing work when, in its judgment, the findings of fact justify such an extension. The DISTRICT's finding of fact thereon shall be final and conclusive on the parties hereto. Extension of time shall apply only to that portion of work affected by the delay, and shall not apply to other portions of work not so affected.

ARTICLE 62. PAYMENTS WITHHELD

(a) In addition to amount which DISTRICT may retain under Article entitled "COMPLETION" and Article entitled "PAYMENTS," DISTRICT may withhold a sufficient amount or amounts of any payment or payments otherwise due to CONTRACTOR, as in its judgment may be necessary to cover:

- (1) Payments which may be past due and payable for just claims against CONTRACTOR or any subcontractors, or against and about the performance of work on the Project, including, without limitation, payments made pursuant to the Article entitled "PAYMENTS BY CONTRACTOR."
- (2) The cost of defective work which CONTRACTOR has not remedied.
- (3) Liquidated damages assessed against CONTRACTOR.
- (4) Penalties for violation of labor laws.
- (5) The cost of materials ordered by the DISTRICT pursuant to Article 30 entitled "MATERIALS AND WORK."
- (6) The cost of completion of this Agreement if there exists a reasonable doubt that this Agreement can be completed for the balance then unpaid to CONTRACTOR.
- (7) Damage to DISTRICT, another contractor, or subcontractor.
- (8) Site clean-up as provided in Article 41 entitled "CLEANING UP."
- (9) Payments to indemnify, defend, or hold harmless the DISTRICT.
- (10) Any payments due to the District including but not limited to payments for failed tests, utilities or imperfections.
- (11) Extra services for ARCHITECT, or PROJECT MANAGER.
- (12) Extra services for the INSPECTOR including but not limited to reinspection required due to CONTRACTOR's failed tests, or installation of unapproved or defective materials, and CONTRACTOR's premature or invalid requests for inspection, and CONTRACTOR's failure to attend the inspection.
- (13) Failure of CONTRACTOR to submit on a timely basis, proper and sufficient documentation required by the Project Documents, including without limitation, monthly progress schedules, shop drawings, submittal schedules, schedule of values, product data and samples, proposed product lists, executed change orders and verified reports.
- (14) Any other obligation(s) of the DISTRICT which the DISTRICT is authorized and/or compelled by law to perform.

(b) If the above grounds are in the opinion of the DISTRICT removed by or at the expense of CONTRACTOR, payment shall be made for amounts withheld because of them.

(c) DISTRICT may apply such withheld amount or amounts to payment of such claims or obligations at its discretion. In so doing, DISTRICT shall make such payments on behalf of CONTRACTOR. If any payment is so made by DISTRICT, then such amount shall be considered as a payment made under contract by DISTRICT to CONTRACTOR and DISTRICT shall not be liable to CONTRACTOR for such payments made in good faith. Such payments may be made

without prior judicial determination of claim or obligations. DISTRICT will render CONTRACTOR an accounting of such funds disbursed on behalf of CONTRACTOR.

(d) As an alternative to payment of such claims or obligations, DISTRICT, in its sole discretion, may reduce the total contract price as provided in Article 59 entitled "ADJUSTMENTS TO CONTRACT PRICE."

ARTICLE 63. TAXES

(a) CONTRACTOR will pay all applicable federal, state and local taxes on all materials, labor, or services furnished by it, and all taxes arising out of its operations under the Project Documents.

(b) If under federal excise tax law any transaction hereunder constitutes a sale on which a federal excise tax is imposed and the sale is exempt from such excise tax because it is a sale to a state or local government for its exclusive use, the DISTRICT, upon request, will execute documents necessary to show (1) that the DISTRICT is a political subdivision of the State for the purposes of such exemption and (2) that the sale is for the exclusive use of the DISTRICT. No excise tax for such materials shall be included in any bid price.

ARTICLE 64. NO ASSIGNMENT

The CONTRACTOR shall not assign, transfer, convey, sublet or otherwise dispose of this Agreement or of its rights, title or interest in or to the same or any part thereof. If the CONTRACTOR shall assign, transfer, convey, sublet or otherwise dispose of the Agreement or its right, title or interest therein, or any part thereof, such attempted or purported assignment, transfer, conveyance, sublease or other disposition shall be null, void and of no legal effect whatsoever; and the Agreement may, at the option of the DISTRICT, be terminated, revoked and annulled, and the DISTRICT shall thereupon be relieved and discharged from any and all liability and obligations growing out of the same to the CONTRACTOR, and to its purported assignee or transferee.

ARTICLE 65. NOTICE

Any notice from one party to the other or otherwise under the Agreement shall be in writing and shall be dated and signed by party giving such notice or by a duly authorized representative of such party. Any such notice shall not be effective for any purpose whatsoever unless served in one of the following manners:

(1) If notice is given to DISTRICT, by personal delivery thereof to DISTRICT, or by depositing same in United States mail, enclosed in a sealed envelope addressed to DISTRICT, and sent by registered or certified mail with postage prepaid;

(2) If notice is given to CONTRACTOR, by personal delivery thereof to said CONTRACTOR, or to CONTRACTOR's superintendent at site of Project, or by depositing same in United States mail, enclosed in a sealed envelope addressed to said CONTRACTOR at its regular place of business or at such address as may have been established for the conduct of work under this Agreement, and sent by registered or certified mail with postage prepaid;

(3) If notice is given to surety or other persons, by personal delivery to such surety or other person, or by depositing same in United States mail, enclosed in a sealed envelope, addressed to such surety or person at the address of such surety or person last communicated by surety or other person to party giving notice, and sent by registered or certified mail with postage prepaid.

ARTICLE 66. NO WAIVER

The failure of the DISTRICT in any one or more instances to insist upon strict performance of any of the terms of this Agreement or to exercise any option herein conferred shall not be construed as a waiver or relinquishment to any extent of the right to assert or rely upon any such terms or option on any future occasion.

ARTICLE 67. NON-UTILIZATION OF ASBESTOS MATERIAL

(a) The CONTRACTOR will be required to execute and submit the Certificate Regarding Non-Asbestos Containing Materials.

(b) Should asbestos containing materials be installed by the CONTRACTOR or any SUB-CONTRACTOR in violation of this certification, or if removal of asbestos containing materials is part of the Project, decontaminations and removals will meet the following criteria:

(1) □ Decontamination and removal of work found to contain asbestos or work installed with asbestos containing equipment shall be done only under the supervision of a qualified consultant, knowledgeable in the field of asbestos abatement and accredited by the Environmental Protection Agency (EPA).

(2) The asbestos removal contractor shall be an EPA accredited contractor qualified in the removal of asbestos and shall be chosen and approved by the asbestos consultant who shall have sole discretion and final determination in this matter.

(3) The asbestos consultant shall be chosen and approved by the DISTRICT who shall have sole discretion and final determination in this matter.

(4) The work will not be accepted until asbestos contamination is reduced to levels deemed acceptable by the asbestos consultant.

(c) Cost of all asbestos removal, including, but not necessarily limited to the cost of the asbestos removal contractor, the cost of the asbestos consultant, analytical and laboratory fees, time delays and additional costs as may be incurred by the DISTRICT shall be borne entirely by the CONTRACTOR.

(d) Hold Harmless: Interface of work for the Project with work containing asbestos shall be executed by the CONTRACTOR at his/her risk and at his/her discretion with full knowledge of the currently accepted standards, hazards, risks and liabilities associated with asbestos work and asbestos containing products. By execution of the Agreement, the CONTRACTOR acknowledges the above and agrees to hold harmless the DISTRICT, its Governing Board, employees, agents, and ARCHITECT and assigns for all asbestos liability which may be associated with this work. The CONTRACTOR further agrees to instruct his/her employees and all SUB-CONTRACTORS with respect to the above mentioned standards, hazards, risks and liabilities.

ARTICLE 68. LEAD

(a) The CONTRACTOR will be required to execute and submit the Lead Containing Materials Notice and Certification.

(b) Pursuant to the Lead-Safe Schools Protection Act (Education Code Sections 32240, et seq.) and other applicable law, the CONTRACTOR or any SUB-CONTRACTOR shall not use lead-based paint, lead plumbing and solders, or other potential sources of lead contamination in the construction of any new school facility or the modernization or renovation of any existing school facility.

ARTICLE 69. CRIMINAL RECORDS CHECK

Education Code Section 45125.1 provides that if the employees of any entity that has a contract with a school district may have any contact with pupils, those employees shall submit or have submitted their fingerprints in a manner authorized by the Department of Justice together with a fee determined by the Department of Justice to be sufficient to reimburse the Department for its costs incurred in processing the application. The CONTRACTOR or any SUB-CONTRACTOR shall not permit an employee to come in contact with DISTRICT pupils until the Department of Justice has ascertained that the employee has not been convicted of a violent or serious felony. The CONTRACTOR or any SUB-CONTRACTOR shall certify in writing to the Governing Board of the DISTRICT that none of its employees who may come in contact with pupils have been convicted of a violent or serious felony. Criminal Records Check Certification by CONTRACTOR and SUB-CONTRACTOR is included in the Project Documents.

ARTICLE 70. TOBACCO FREE POLICY

(a) The CONTRACTOR will be required to execute and submit the Tobacco Free Work Place Certification.

(b) CONTRACTOR has been advised and is aware that DISTRICT has adopted a Board Policy which prohibits the use of tobacco products, including smokeless tobacco, anywhere on DISTRICT property. CONTRACTOR shall be responsible for the enforcement of DISTRICT's tobacco-free policy among all CONTRACTOR's employees and subcontractors while on DISTRICT property. CONTRACTOR understands and agrees that should any employee or subcontractor of CONTRACTOR violate the DISTRICT's Board Policy after having already been warned once for violating DISTRICT's tobacco-free policy, CONTRACTOR shall remove the individual for the duration of the Project. CONTRACTOR shall not be entitled to any additional compensation and/or time in completing the Project for such removal.

ARTICLE 71. GOVERNING LAW

The laws of the State of California shall govern the Project and the Agreement.

□□□□

SHOP DRAWING TRANSMITTAL
General Conditions Article 20

The procedure governing shop drawing and material samples or submittals is contained in the General Conditions. In addition, all Supplementary General Conditions, and Specifications must be followed by the CONTRACTOR.

Failure to comply with all requirements will constitute grounds for return of the shop drawing for proper resubmittal. CONTRACTOR shall sequentially number each submittal.

Date: _____ Submittal No.: _____

From: _____ To: _____

Project Name: 2021 District-Wide Contract for the Purchase, Lease, Relocation, Dismantling,
and Removal of Division of the State Architect (DSA) Approved Portable
Buildings Project No: SSPU, #40-04/2020-21

This is a(n): Original _____

 Submittal _____

 2nd Submittal _____

 [] Submittal _____

Subject of Submittal:	Equipment Designation:	Specification Section(s):
-----------------------	------------------------	---------------------------

Complete either (a) or (b)

Check One:

- (a) We have verified that the material or equipment contained in this submittal meets all the requirements specified or shown (no exceptions). _____

- (b) We have verified that the material or equipment contained in this submittal meets all the requirements specified or shown, except for the following deviations (List deviations on attached sheet). _____

The CONTRACTOR has reviewed and approved not only the field dimensions but the construction criteria and has also made written notation regarding any information in the shop drawings that does not conform to the Project Documents. This shop drawing has been coordinated with all other shop drawings received to date by CONTRACTOR and this duty of coordination has not been delegated to subcontractors, material suppliers, the ARCHITECT, or the engineers on this Project.

Signature of Contractor or
Supplier

CHANGE ORDER (Additive) NO. _____
General Conditions Article 57

PROJECT: 2021 District-Wide Contract for the Purchase, Lease, Relocation, Dismantling,
and Removal of Division of the State Architect (DSA) Approved Portable Buildings
Project No: SSPU, #40-04/2020-21

TO: _____

You are hereby directed to provide the extra work necessary to comply with this Change Order.

DESCRIPTION OF CHANGE: _____

COST (This cost shall not be exceeded.):

Original contract price:	\$ _____
Previous Change Orders	\$ _____
Change Order amount:	\$ _____
New contract price:	\$ _____

TIME FOR COMPLETION:

Original completion date:	_____
Previous Change Orders	_____
Time for completion of Change Order:	_____
New completion date:	_____

Contractor agrees to perform the above-described work in accordance with the above terms and in compliance with applicable sections of the Project Documents. The amount of the charges under this Change Order is limited to the charges allowed under Article 59 of the General Conditions. The adjustment in the contract sum, if any, and the adjustment in the contract time, if any, set out in this Change Order shall constitute the entire compensation and/or adjustment in the contract time due Contractor arising out of the change in the work covered by this Change Order, unless otherwise provided in this Change Order.

No additions or deletions to this Change Order shall be allowed, except with written permission of District. Contractor accepts the terms and conditions stated above as full and final settlement of any and all claims arising from this Change Order.

(continued on next page)

This Change Order is hereby agreed to, accepted and approved.

CONTRACTOR

DISTRICT (Savanna S.D.)

By: _____
Signature

By: _____
Signature

Print Name

Print Name

Title

Title

Date

Date

PROGRAM MANAGER

Note: DSA and Architect's approval lines will be added when applicable to individual projects issued under the Master Agreement.

By: _____
Signature

Print Name

Title

Date

CHANGE ORDER (Deductive) NO. _____
General Conditions Article 57

PROJECT: 2021 District-Wide Contract for the Purchase, Lease, Relocation, Dismantling,
and Removal of Division of the State Architect (DSA) Approved Portable Buildings
Project No: SSPU, #40-04/2020-21

TO: _____

You are hereby directed to comply with this Change Order.

DESCRIPTION OF CHANGE: _____

COST (This cost shall be deleted.):

Original contract price:	\$ _____
Previous Change Orders	\$ _____
Change Order amount:	\$ _____
New contract price:	\$ _____

TIME FOR COMPLETION:

Original completion date:	_____
Previous Change Orders	_____
Time for completion of Change Order:	_____
New completion date:	_____

Contractor agrees to deduct the above-described work in accordance with the above terms and in compliance with applicable sections of the Project Documents. Contractor agrees to the adjustment in the contract sum, if any, and the adjustment in the contract time, if any, set out in this Change Order.

No additions or deletions to this Change Order shall be allowed, except with written permission of District. Contractor accepts the terms and conditions stated above as full and final settlement of any and all claims arising from this Change Order.

(continued on next page)

This Change Order is hereby agreed to, accepted and approved.

CONTRACTOR

DISTRICT (Savanna S.D.)

By: _____
Signature

By: _____
Signature

Print Name

Print Name

Title

Title

Date

Date

PROGRAM MANAGER

Note: DSA and Architect's approval lines will be added when applicable to individual projects issued under the Master Agreement.

By: _____
Signature

Print Name

Title

Date

LEASE AGREEMENT

XXXX

BASIC LEASE INFORMATION

A. PARTIES:

Lessor: _____

Lessee: _____ District

B. DATE OF LEASE: [Insert Date]

C. BASIC LEASE PROVISIONS:

1. Property: ____ () relocatable building(s), serial number(s) _____, of approximately _____ () square feet, per Proposal dated _____, 2020, pursuant to the Savanna School District's 2021 District-wide contract for the Purchase, Lease, Relocation, Dismantling and Removal of Division of the State Architect (DSA) Approved Portable Buildings Bid No. SSPU #40-04/2020-21 incorporated herein by reference.

2. Term: _____.

3. Commencement Date: [insert date]

4. Expiration Date: [insert date]

5. Permitted Use: Classroom/Educational Use.

6. Location of Installation: _____.

7. Base Rent: Annual Rent of \$_____.
Monthly Rent of \$_____.

8. Address for Notices:

Lessor: _____

Lessee: _____

9. Delivery and installation fee: Delivery \$_____ / Installation \$_____.

10. Dismantle and Return fee: Dismantle \$_____ / Return \$_____.

11.□ Improvements (if applicable): _____

This Lease Agreement ("Lease") is made as of _____, 2020, by and between _____ ("Lessor"), and _____ District, a public educational institution ("Lessee"). The parties shall be referred to herein individually as "Party" and cumulatively as "Parties."

1. LEASE

Subject to the terms and conditions set forth in this Lease, and the Savanna School District contract awarded pursuant to Bid #SSPU #40-04/2020-21, Lessor leases to Lessee the Property (as defined in Paragraph [C.1.] of the Basic Lease Information).

2. TERM; DELIVERY OF PROPERTY; CONDITION OF THE PROPERTY; LESSOR'S WORK

2.1. Term. The Lease Term ("Term") shall be _____ as set forth in Paragraph [C.2.] of the Basic Lease Information, commencing on the Commencement Date, as set forth in Paragraph [C.3.], and ending on the Expiration Date set forth in Paragraph [C.4.].

2.2. Delivery of Property. Lessor shall deliver the Property to Lessee subject to Section [2.3.] below. In the event of any delay in the delivery of the Property to Lessee, this Lease shall not be void or voidable, however, Lessor shall be liable to Lessee for any loss or damage resulting from such delay and the Base Rent set forth in Paragraph [C.7.] of the Basic Lease Information shall be adjusted due to the delay.

2.3. Condition of the Property. Lessor represents and warrants that the Property is suitable for the conduct of Lessee's business. Lessor shall have no obligation to make or pay for any improvements or renovations to the Property to prepare the Property for Lessee's occupancy, unless so agreed upon between the Parties in writing. The taking of possession of the Property by Lessee shall conclusively establish that the Property is in good order, condition and repair.

2.4. Lessor's Work. Upon delivery of the Property to Lessee, Lessor shall install the Property at the Location as set forth in Paragraph [C.6.] of the Basic Lease Information. Lessor shall provide all labor, materials, and services required for the construction and installation of the Property per any approved plans as set forth in the Basic Lease Information Paragraph [C.1.]. The Property shall be fully furnished with all electrical and heating, ventilation and air conditioning (HVAC) required by the Lessee. Lessor's work shall not include any site work, including, but not limited to connection of utilities, ramp extensions and inspections. Lessee shall pay to Lessor a delivery and installation fee, per Paragraph [C.9] of the Basic Lease Information. The fee shall be paid by Lessee with the first lease payment due or as otherwise agreed in writing. Upon termination of this Lease as provided for herein, Lessor shall dismantle said Property from the Location. Lessee shall pay to Lessor a dismantle and return fee per Paragraph [C.10.] of the Basic Lease Information.

3. BASE RENT

Lessee shall pay on the Commencement Date, without prior notice, deduction or offset, the amounts set forth as Base Rent in Paragraph [C.7] of the Basic Lease Information.

4. USE OF PROPERTY

The Property shall be used for classroom or normal educational purposes by Lessee and such ancillary uses as shall be reasonably required in connection therewith and for no other use or uses without the prior express written consent of Lessor.

5. PROHIBITED USES

Lessee shall not use or allow the Property to be used in violation of any law or rule or regulation, or for any improper or unlawful use. Lessee shall not do or permit to be done anything that will cause cancellation of any fire, casualty, liability, or other insurance policy insuring the Property. Lessee shall not cause, maintain or permit any nuisance in, on or about the Property. In addition, Lessee shall not remove the Property from the Location set forth in Paragraph [C.6.] of the Basic Lease Information without the prior written approval of Lessor. Moreover, any and all delivery, installation, dismantling or removal of the Property shall be done solely by Lessor, unless otherwise authorized in writing by Lessor.

6. LESSEE'S MAINTENANCE AND REPAIR

6.1. Lessee's Maintenance and Repair Obligation. Lessee, at Lessee's sole cost and expense, shall keep the Property in good condition and repair, normal wear and tear and damage by fire or other casualty excepted. Only minor routine maintenance shall be performed on the Property by Lessee, such as electrical connections, replacing light bulbs, and custodial services.

6.2. Lessor's Right to Make Repairs. Lessee shall give Lessor prompt written notice of any damage to or defective condition in any part of the Property. Upon such notice, the Parties shall come to an agreement as to the necessity and extent of repairs required for the Property. If Lessee was required to make such repairs as required by the Lease, Lessor may, after written notice to Lessee and Lessee's failure to repair within ten (10) business days of receipt of Lessor's notice, make such repairs. Lessee shall reimburse Lessor upon receipt of an invoice, all costs incurred by Lessor in performing any such repair on account of Lessee.

7. LESSEE'S FURNISHINGS AND ALTERATIONS

7.1. Lessee's Furnishings. Lessee shall be permitted to install any and all school furniture and furnishings ("Furnishings") in the Property as is required for usual school purposes. All Furnishings shall be installed at Lessee's sole expense and shall remain the sole property and responsibility of Lessee.

7.2. Removal of Furnishings. Any Furnishings installed by Lessee shall be removed by Lessee, at Lessee's sole cost, at the expiration or sooner of this Lease and the Property shall be restored by Lessee to its condition prior to the installation of the Furnishings, ordinary wear and tear excepted.

7.3 Unpermitted Furnishings. Aside from Furnishings authorized in Section [7.1] above, Lessee shall not be permitted to make any other alterations to the Property without the prior written consent of Lessor.

7.4 Lessee's Alterations. Lessee, at Lessee's sole cost and expense, shall be permitted to make alterations to the Property upon prior written approval by Lessor. Such alterations shall include, but not be limited to, changes to the layout of the Property, installation of low voltage electrical outlets, and installation of partition walls that are necessary for the Lessee's educational purposes.

8. LESSEE'S INSURANCE

Lessee will cause its own all risk insurance property policies to be extended to cover the Property with endorsements in the name of the Lessor as its interest may appear. Lessee will also cause Lessor to be named as additional insured in its public liability policy to the extent of the Lessee's operations of the said Property for as long as this Lease is in force.

9. INDEMNIFICATION

9.1. Indemnification of Lessor. Lessee shall indemnify, defend, protect, and hold harmless Lessor from any and all claims, losses, costs, damages, expenses and liabilities (including without limitation court costs and reasonable attorneys' fees) ("Claims") to the extent arising from any negligent acts or negligent omissions of Lessee arising out of this Lease, or any breach by Lessee of the terms and conditions of this Lease.

9.2. Indemnification of Lessee. Lessor shall indemnify, defend, protect, and hold harmless Lessee from any and all claims, losses, costs, damages, expenses and liabilities (including without limitation court costs and reasonable attorneys' fees) ("Claims") to the extent arising from any negligent acts or negligent omissions of Lessor arising out of this Lease or any breach by Lessor of the terms and conditions of this Lease.

9.3. Survival. The provisions of this Section 9 shall survive the expiration or earlier termination of this Lease with respect to any claims or liability arising in connection with any event occurring prior to such expiration or termination.

10. DESTRUCTION OF PROPERTY

Lessee shall promptly notify Lessor in writing of any destruction of or irreparable damage to the Property resulting from fire or any other casualty. Lessor and Lessee shall mutually agree on the appropriate course of action regarding the Lease. Lessor shall not be obligated to repair or replace any of Lessee's Furnishings, such as movable furniture, equipment, trade fixtures and other personal property, due to destruction of or irreparable damage to the Property.

11. SURRENDER OF PROPERTY; OWNERSHIP AND REMOVAL OF FURNISHINGS

On the Expiration Date as set forth in Paragraph [C.4.] of the Basic Lease Information, or earlier termination of this Lease, Lessee shall surrender the Property to Lessor vacant and broom-clean, except for reasonable wear and tear. Lessee shall remove all Lessee's Furnishings prior to the Expiration Date or termination of the Lease.

12. COMPLIANCE WITH LAWS

Lessor and Lessee shall comply with any law, statute, zoning restriction, ordinance, rule, regulation or requirement of duly constituted public authorities now in force or which may hereafter be in force ("Applicable Laws") relating to or affecting the construction, condition, use or occupancy of the Property.

13. DEFAULT BY LESSEE AND REMEDIES UPON DEFAULT

13.1. Events of Default. The occurrence of any of the following shall constitute an "event of default" on the part of Lessee:

(i) Nonpayment of Rent. Failure to pay any installment of Rent due and payable in this Lease on the date when payment is due after reasonable efforts by Lessor have been exhausted to collect;

(ii) Other Obligations. Failure to perform any material obligation under this Lease and such failure continues for a period of thirty (30) calendar days after Lessor's written notice of such failure.

13.2 Remedies Upon Default. If an event of default by Lessee occurs, Lessee shall be deemed in breach of the Lease and Lessor shall have, in addition to any other remedies available to Lessor at law or in equity, the right to terminate this Lease, in which event Lessee shall immediately surrender the Property to Lessor, and if Lessee fails to do so, Lessor may, without prejudicing any of the remedies that Lessor may have under this Lease, at law or in equity, take possession of the Property.

13.3. Waiver of Breach. The waiver by Lessor of any breach by Lessee of any of the provisions of this Lease shall not constitute a continuing waiver or a waiver of any subsequent default or breach by Lessee either of the same or a different provision of this Lease. The subsequent acceptance of Rent by Lessor shall not be deemed to be a waiver of any preceding breach at the time of acceptance of such payment. No term of this Lease shall be deemed to have been waived by Lessor unless the waiver is in writing signed by Lessor.

14. DEFAULT BY LESSOR AND REMEDIES UPON DEFAULT

14.1 Event of Default by Lessor. Lessor shall be in default if Lessor fails to perform any material obligation under this Lease, and such failure continues for a period of thirty (30) calendar days after Lessee's written notice of such failure.

14.2 Remedies Upon Default. If an event of default by Lessor occurs, Lessor shall be deemed in breach of the Lease and Lessee shall have, in addition to any other remedies available to Lessee at law or in equity, the right to terminate this Lease, in which event Lessor shall immediately dismantle and remove the Property at Lessor's sole cost and expense, and if Lessor fails to do so, Lessee may, without prejudicing any of the remedies that Lessee may have under this Lease, at law or in equity, take possession of the Property, dismantle, remove and store the Property at Lessor's cost and expense.

14.3 Waiver of Breach. The waiver by Lessee of any breach by Lessor of any of the provisions of this Lease shall not constitute a continuing waiver or a waiver of any subsequent default or breach by Lessor either of the same or a different provision of this Lease. No term of this Lease shall be deemed to have been waived by Lessee unless the waiver is in writing signed by Lessee.

15. NOTICES

Notices in Writing; Method of Delivery. Except as otherwise expressly provided by law, any and all notices given under this Lease shall be in writing, to either Party at the appropriate address set forth in the Basic Lease Information, or to such other place as either party may from time to time designate in a written notice to the other, and shall be deemed duly given when personally delivered or sent by United States certified or registered mail, postage prepaid, return receipt requested, with notice effective three (3) days after the date it is posted.

16. ATTORNEY'S FEES

If any litigation is commenced between Lessor and Lessee, each Party shall be responsible for its own attorney's fees and costs.

17. MISCELLANEOUS

17.1. Force Majeure. Acts of God, an inability to obtain services, labor, or materials or reasonable substitutes therefor due to governmental actions, civil commotions, and other causes beyond the reasonable control of the Party obligated to perform, (collectively, a "Force Majeure") shall excuse the performance of such Party for a period equal to any such prevention, delay or stoppage to perform under the Lease.

17.2. Binding Effect. This Lease shall be binding on and shall inure to the benefit of the heirs, executors, administrators and successors of the Parties.

17.3 No Assignment. This Lease shall not be assigned or transferred by either Party.

17.4 Venue. The venue for resolution of any dispute between the Parties concerning this Lease shall be the County of Orange. The Parties hereby expressly waive all rights they may have to a change of venue.

17.5 Time of Essence. Time is expressly declared to be of the essence in this Lease.

17.6 Severability. If any term or condition of this Lease shall, to any extent, be invalid or unenforceable, the remainder of this Lease, or the application of such term or condition to persons or circumstances other than those with respect to which it is invalid or unenforceable, shall not be affected thereby, and each term and condition of this Lease shall be valid and enforceable to the fullest extent permitted by law.

17.7 Entire Agreement. It is understood and acknowledged that there are no oral agreements between Lessor and Lessee respecting the leasing of the Property and this Lease constitutes the Parties' entire agreement with respect to the leasing of the Property. Any agreement or understanding or representations respecting the Property or their leasing by Lessor to Lessee not expressly set forth in this Lease are null and void. None of the terms, covenants, conditions or provisions of this Lease can be modified or deleted except in writing signed by Lessor and Lessee.

IN WITNESS WHEREOF the Parties hereto have caused this Lease to be executed and authorized as indicated immediately below.

LESSOR

LESSEE

_____ DISTRICT

By: _____
Name: [Signer's Name]
Title: [Signer's Title]

By: _____
Name: [Signer's Name]
Title: [Signer's Title]

TECHNICAL SPECIFICATIONS – RELOCATABLE BUILDINGS,
CLASSROOMS AND RESTROOMS

A. GENERAL REQUIREMENTS

1. Summary: These specifications describe new and used prefabricated, relocatable buildings of classroom, restroom, and other School type buildings based on pre-approved DSA drawings or specifications. No changes to these pre-approved specifications will be permitted without prior written approval from the District.

2. DSA Pre-Approval: All refurbished buildings provided shall have adequate documentation of prior DSA approval, either PC, stockpile, or site-specific A# sufficient to allow District's Architect of Record for new site to obtain DSA approval for placement at school sites specific to this contract. It shall be the sole responsibility of the successful bidder to provide the above-stated documentation as a condition of sale, lease or lease purchase of buildings.

3. Applicable Documents: The following documents shall be the latest issue as adopted by the State of California at the time of the bid opening, and shall form a part of this specification to the extent they are applicable.
 - a. California Administrative Code (CAC)
 - b. Title 5 - Education Code
 - c. Title 19 - Public Safety
 - d. Title 20 - Public Utilities
 - e. Title 21 - Public Works Title 24 - Building Code
 - f. Title 25 - Housing Community Development
 - g. American Welding Society - Standard Qualification
 - h. Procedures American Wood Preservative Association
 - i. ASHRAE
 - j. California Electrical Code
 - k. California Building Code, Title 24, including California Energy Code

- l. ASTM C635 - Metal Suspension Systems for Acoustical Tile and lay-in Panel
 - m. State of California Specification 7220-XXX-01, Carpet
 - n. Interpretations of Regulation (IR) issued by the Division of the State Architect
 - o. Americans with Disabilities Act (ADA)
 - p. National Fire Protection Association NFPA 90A
 - q. National Warm Air Heating and Air Condition Association
 - r. National Electrical Code
 - s. Uniform Building Code
4. Site Specific Plan Approval by the Division of the State Architect: The Contractor shall submit one (1) digital copy (PDF) plans and specifications including as applicable, to the District's Architect within twenty-one (21) business days for each building type (cumulative) after receipt of District executed contract/purchase order for buildings.
- a. All plans, specifications and calculations must be signed by contractors(s), P.O.R., who shall be licensed by the State of California. For modifications to the base bid; the time frame for submittal shall be negotiated between District, Architect and Contractor. Any notations or corrections required by the District Architect shall be incorporated into the plans and specifications, and they shall be returned to the District Architect within fifteen (15) business days in the form of one (1) digital copy (PDF).
 - b. After corrections (if any) as noted by the District Architect have been made, the District Architect shall obtain approval from the DSA. If the DSA requires changes in the plans or specifications, the Contractor shall accomplish the changes and resubmit the corrected documents to the District Architect within fifteen (15) business days.
 - c. The District, after the Architect receives DSA approval, shall furnish one pdf set of electronic plans and specifications for each DSA approval number and for each site to the Contractor, for the Contractor's use. Contractor shall print and distribute to sub-contractors and suppliers as needed.

- d. District will make any payment required in obtaining DSA approvals. The time to complete the project will be increased day for day, for each and every day required for DSA approval.

Inspection: Inspection of prefabricated buildings is divided into two (2) separate functions: (1) In-Plant Inspection and (2) On-Site Inspection. All requirements of Title 19 and 24 of the State of California Code of Regulations relating to inspection and verified reports shall be compiled with and shall include:

- a. The District shall retain and pay for all Inspectors.
- b. Inspection, material testing and DSA documentation (i.e.: Form SSS-6) shall be accomplished under the supervision of the District Architect. The Contractor shall notify the District Architect and the designated inspectors at least forty-eight (48) hours prior to commencing work. The In-Plant Inspector shall be responsible for, and be approved to inspect all phases of work under-taken in the factory or plant.
- c. The manufacturer shall provide the Inspector with full access to all plant operations involving work under this contract and shall advise the Inspector in advance of the time and place when operations that the Inspector wants to observe take place. Before building(s) are removed from the plant for delivery to the site or storage facility, or from storage facility to the site, the Inspector and District Architect shall determine that they are acceptable and issue a written release, which shall be in the form of a Verified Report (Form SSS-6).
- d. The Site Inspector (Inspector of Record) shall do all on-site inspection. Only the work, which the manufacturer or his subcontractors perform at the site, shall be subject to the inspection of the Site Inspector. The manufacturer will furnish the Site Inspector with such information as may be necessary to keep him fully informed as to progress of work and dates when site work will occur. The Contractor shall notify the District at least forty-eight (48) hours prior to commencing on-site work. The on-site Inspector of Record shall be responsible for and approved to inspect all phases of work under his control.
- e. The Division of the State Architect may require special testing and or inspections. All costs for these tests and or inspections shall be borne by the District.

5. □ Site Readiness Preparation: All site conditions not under Contractor's direct control are to be the District' responsibility. It is the District's responsibility to notify the Contractor when the site is ready for delivery. In the event buildings are delivered to any site that is not in condition to receive buildings, the District shall be responsible for all cost incurred, including, but not limited to: relocation fees, storage fees, security, acts of vandalism, redelivery costs, crane costs, set up, Contractor down time, and Contractor's costs.
6. □ Building Additive Alternates: All additive alternates shall meet or exceed the specifications for the base buildings, unless otherwise noted in this section. If a specification for an alternate cannot be found in the bid documents, an interpretation of what is normal and customary in the modular and construction industry shall prevail.

B. GENERAL SCOPE REQUIREMENTS

1. □ General: The Base Building for new construction, except where noted in building specific specifications, will include 50# PSF wood floor, 20# PSF roof, 2 x 4 wood studs, 22 gauge single slope roof with 5' front overhangs and 2'6" rear overhangs, R-13 floor/ wall insulation and R-19 attic insulation, 3.5 ton wall mount heat pump (wood foundation included – no carpet, no ramps, no landing/ramps included).
2. □ Two Story Relocatable Building: Provide two story relocatable modular building as per approved PC. The overall construction of the unit shall meet the specifications of the base bid classroom units, except as noted. Incorporate shear, brace or moment frame design or any other structural design that is acceptable to the DSA. Construction shall be Type II or V (One Hour) or Type II or V (Sprinkler). Fire sprinkler shall be a wet pipe system constructed to NFPA 13 using “Pipe Method” for sizing pipe.
3. □ High Performance Building: Provide a high-performance learning environment as per approved A# with low and no-VOC finishes, paints and adhesives and sound absorbing surfaces throughout the building, fully day-lit with large high performance windows at the front and rear along with clerestory windows and tubular skylights, barrel radius roof design with exposed modline trusses, net zero option.

4. Not in contract/provided by District:

- a. Utilities: The electrical service drop connection(s) and plumbing connection(s) to the building(s) are not part of the base bid. Fire alarm system, program bell, clock system, public address system, intercom system, TV system, wiring (and conduit, or boxes except as noted on the manufacturer's approved drawings) are also not part of the base bid.
- b. Building Pad: The site will be turf-free, cleared and graded to within two inches (2") of level grade in any direction for each building. Any cost extra due to the site not meeting this two inch grade will be the responsibility of the District. The District will provide a survey locating the building corners and the finish floor elevation
- c. Delivery Access: The District will insure that the site is accessible for standard industry vehicles and equipment required for placement of relocatable units. District will prepare approaches to the site as required. The Contractor will be provided unobstructed delivery access to the location of each building.
- d. Soils Conditions: Each site will have a minimum soil bearing capacity of 1,000 PSF with a moisture density ratio of 90% minimum. However Contractor has the option to use an existing or new soils report to configure building placement, footings and or foundations per approved drawings.
- e. All signage that may be required by DSA, District or other agencies is not in the base bid.

5. Design Requirements: The modules are to be designed so that one or more modules may be joined together to form a complete building; to maintain a positive alignment of floors, walls, ceilings and roof and to permit simple nondestructive detachment for future relocation.

- a. Each module shall be permanently identified with a metal identification tag 3"x1 1/2" minimum size with the following information: Design wind load, Design roof live load, and the Design floor live load. This tag may be in addition to or combined with the identification tag required by the Division of the State Architect.

- b.□Each module shall be capable of resisting all vertical and lateral loads during transportation and relocation. When modules are assembled, joints shall be sealed with removable closing strips or other method to present a weather tight and finished appearance.
- c.□Each module shall be sufficiently rigid to be jacked up at the front and back corners for relocation without damage or the module shall have lift lugs at the front and back located as required so that the module may be jacked up for relocation in one piece without damage. These requirements shall be met without additional supports of any type.

C. TECHNICAL SCOPE REQUIREMENTS

1.□Dimensions: All buildings will meet a square footage tolerance of plus or minus five (5) square feet. The classroom buildings shall occupy a minimum area of nine hundred sixty (960) square feet. The classroom buildings shall be: 24'x40', 24'x60, 30'x32', 36'x40', or 48'x40', (additional Modules shall be 12'x40', 12'x60' or 10'x32'). The restroom buildings shall be 8.5'x15.5' and 8'6"x21'6", 8.5'x30' or 12'x40'. All other building types shall be per individual specifications.

- a.□Fascia and required overhangs are not included in the calculation of the square footage the building occupies. Each floor shall have a full length 26-gauge gutter and 24-gauge downspouts shall be furnished at the end of each overhang where drainage occurs.
- b.□The interior height, floor to ceiling shall be a minimum of eight feet six inches plus/minus one inch (8'6 +/- 1"). Ceiling height for restrooms shall be a minimum of eight feet plus/minus one inch (8'0 +/- 1"). The module shall be clear span type except as provided for in snow load buildings.

2.□Load Criteria: Design criteria for base bid buildings will be: per submitted PC or stockpile plans:

Soil Bearing Pressure	=	1,000 psf (Wood Foundations)
		1,500 psf (Concrete Foundations)
Continuous Footing Width	=	12" (minimum)

Isolated Footing Width	=	36” square (minimum)
Footing Depth	=	12” below lowest adjacent grade
Liquefaction Potential	=	None
Seismic Settlement	=	None
Differential Settlement	=	None
Soil Corrosivity	=	Low (No Special Measures / Protection Required)
Mapped Seismic Hazards	=	None
Wind Speed	=	129 (Ultimate, 3 Second Gust) (at new buildings)
Wind Exposure	=	C
Floor Live Load	=	50 psf (50+15 psf at partition locations)
Roof Live Load	=	20 psf
Roof Snow Load	=	None

a. Modules delivered to locations requiring roof live loads or wall wind loads greater than the minimums required by Title 24 CAC or design details specified herein shall meet the live load and wind load criteria required in the location in which the building is installed. The District will be responsible for the extra cost of manufacturing the building to meet these roof and wind loads.

3. Wood Pad Foundations: All material for use in ground contact shall be stamped "For Ground Contact". Each piece of pressure treated material shall be stamped with appropriate AWA stamp. Wood shall be of a naturally decay resistance species or pressure impregnated with an effective preservative when embedded in, or laid on a concrete slab that is in contact with the earth, or resting on concrete or masonry walls that are 12" or less above the ground. Ends of wood joints that are 1" or less above finished outside grade, or abut or are incased in concrete or masonry shall have a minimum treatment of an effective preservative. Foundation grade redwood or All Heart foundation grade cedar will be considered naturally decay resistant when grade marked at the mill.

a. Installation shall be permitted on turf free soil having suitable design-bearing capacity. The buildings shall be securely fastened to the foundations. The foundations and the method of fastening shall be subject to approval by the DSA (and/or per approved plans).

4. Concrete Foundations: Concrete foundations may be requested by the District(s) as indicated on the Bid Form. The Contractor shall prepare the design of concrete foundations. Such design shall vary in accordance with the site soil conditions, 1500 PSF is the minimum required. The footing design shall provide for shims and blocks necessary to permit installation on sites not level, but within the 1/2" allowable tolerance. The District and/or District Onsite Contractors will be responsible for all surveying, staking the building comers, setting the finish floor elevation, excavation, removal of spoils and backfill (unless included as a line item in the contract scope.) Ramp(s) and landing(s) are not included when the Contractor provides a concrete foundation.

- a. The eighteen-inch (18") option shall be per the specifications with the 18" clearance under building from purlins to the ground.
- b. The foundation and the method of fastening the units shall be as previously approved by the DSA.
- c. High strength grout shall be Embecco non-shrink, metallic aggregate grout or equal.
- d. The design concrete foundations will be as follows:
 - i. All work and materials shall conform to Title 24, California Code of Regulations, and Chapter 19 and the American Concrete Institute (ACI): Building Code requirements for reinforced concrete, AC131883, and the American Society for Testing and Materials (ASTM): The Specifications and standards hereinafter referenced to shall be of the latest edition.
 - ii. Design mixes shall be as specified in Title 24. Concrete strength at 28 days shall be as follows: Slab - 2,500 psi; Lightweight - 3,000 psi.
 - iii. Forms shall be substantial, plumb, level, square, true to line, water tight and accurate to the dimensions required.
- e. The Architect shall approve location of Mechanical and Electrical openings in the concrete and the installation of sleeves as may be required; and openings provided for under floor crawl access wells, or vent wells for under floor ventilation.
- f. Variance in concrete slab surface shall be no more than 1/16" inch in 10 feet.

5. Framing: Roof Walls and Floor: The buildings shall be a shear wall, brace frame or moment-resistant rigid steel frame or any other structure acceptable to DSA. Steel frame

building/steel frame construction shall meet the minimum design requirements of stud spacing, etc. as per latest edition of C.B.C. listed below. All work and materials shall conform to the "Specification for the Design, Fabrication, and Erection of Structural Steel for Buildings" and "Code of Standard Practice for Steel Buildings and Bridges," American Institute of Steel Construction: Title 24, CCR and Uniform Building Code, 1995 Edition. Structural steel shall be made either the open-hearth or electric furnace process only and shall conform to the "Specification for Structural Steel" ASTM Designation A36, current edition.

- a. Roof framing, floor framing and wall framing shall be per Manufacturers' PC or Stockpile Plans and per all applicable codes.
- b. All structural members below the sub floor, i.e. Girders, joists, headers, blocking, shall be steel. Minimum joist spacing shall be 48".
- c. All work shall conform to the requirements of the AISC Standard Specifications, the applicable regulatory agency and the American Iron and Steel Institute Specifications for Design or Light Gauge Steel Structural Members. Welding: Shall comply with the pertinent provisions of the applicable regulatory agency. All welding shall be done by operators who are qualified as prescribed in the "Qualification Procedure" of the American Welding Society to perform the type of work required
- d. Steel shall be coated with one shop coat of manufacturer's standard chassis paint and or equal.
- e. Plywood: American Plywood Association PS 1-83. Each sheet shall be grade marked by the American Plywood Association, and shall conform to the requirements of Standard Grade Group 1 or better grade stamped and identified under the procedures and qualification set forth by PSI-83.
 - i. Plywood Sub floor: 1-1/8". Provide seamless woven polyflex bottom board for moisture protection.
 - ii. Optional plywood roof deck: 3/4" plywood square edge or equal.
 - iii. Siding: Standard: 5/8" Duratemp, Optional: 5/8" Exterior Siding, or 5/8" CDX plywood interior shear plywood, or dens glass fiberboard when applying alternate exterior applications.

- f. Building tolerances:
 - i. Framing members: 1/4 inch from level, 1/4 inch per 10 feet from plum.
 - ii. Siding and roofing: 1/4 inch from true position

- 6. Moisture Barrier: All weather-exposed surfaces shall have a weather-resistive barrier to protect the interior wall covering. Such barrier shall be equal to that provided for in CBC Standard No. 17-1 for Kraft waterproof building paper of CBC Standard No. 32-1 for asphalt-saturated rag felt. Barrier shall be free from holes and breaks other than those created by fasteners and construction system due to attaching of the building siding, and shall be applied over studs or sheathing of all exterior walls. Such barrier shall be applied under siding weatherboard fashion, lapped not less than two inches (2") at horizontal joints and not less than six inches (6") at vertical joints.

- 7. Siding: All siding shall be APA or comparable rated exterior type. Each panel shall be identified with the grade mark of the grading association and shall meet the requirements of Product Standards PS 1-95. Siding shall be 19/32" (minimum) thick. with one (1) of the following styles: plain, V-grooved, grooved, or reverse board and batten.

- 8. (Optional) Exterior Coverings: When included in the line item scope, submittals will be provided of color chips from manufacturer's standard colors to the District Architect for color choice, for:
 - a. STO Dry Vit Synthetic Coatings
 - b. Portland Cement Plaster

- 9. Skirting: Skirting shall be plain ungrooved or grooved. Material shall be used where the long direction of the sheet runs horizontal. All edges and the bottom of the skirting shall be supported and the entire space below the building shall be closed off. Maintain 1-1/2" minimum clearance from the bottom of plywood skirting to finish grade. Provide expanded galvanized metal fresh air vents to compromise a minimum net area meeting a 1 to 150 vent to area ratio.
 - a. Contractor's bid shall reflect the maximum pad slope (2") provided by the District.
 - b. Ramp & Landing Skirting: Ramp and Landing (when used) shall be fully skirted with

the same material used for building skirt. All edges of the skirting shall be supported and protected from weather. Foundation members shall be as for building foundation.

10. **Roofing:** roofing system per UBC Standards (Class A). Design and installation of the deck and roof substrate shall result in the roof draining freely. Roof shall have a minimum pitch of 1/4" per foot.

a. Pre finished, unpenetrated interlocking roof panels mechanically crimped at top to prevent against water infiltration, standing seam or ribbed type, 22-gauge panels

b. Gutters will be 26 ga steel and downspouts will be 24 ga steel at the overhangs of the building where drainage occurs. No splash blocks are included.

c. All fasteners shall be caulked against weather using material resistant to deterioration under ultraviolet light.

d. Roofing Snow Loads: In addition to all standard roofing items, provide full-length silicone or equal sealant at each interlock.

e. Roof Overhang: The roof overhang shall be per the manufacturer's PC or stockpile.

11. **Metal Exterior Doors:** Construct per ANSI A250.8 and A2SOA as minimum requirement: Flush doors 3070, 1-3/4" thick, with 18 gauge steel face sheets and sound-deadening material on interior to effectively reduce metallic ring. Factory to prepare and reinforce for indicated finish hardware, including reinforcement on both faces for closers. Chemically treat doors for paint adhesion, and apply one (1) complete shop coat of metal primer and then paint to match exterior. Curries 607, Amweid SLE or equal doors to be used. All doors to have Pemco 315CN36 door bottoms or equal and Ives 8400 10"x 2" LDW kick plates or equal.

12. **Pressed Metal Frames:** Knock down per CS242 as minimum requirement manufacturer's standard 16-gauge steel, depth to suit wall thickness. Provide one (1) compression anchor minimum per jamb and adjustable floor anchor at bottom of each jamb. Prepare and reinforce for required hardware, including strike box and reinforcement for closers on all frames. Chemically treat frames for paint adhesion, and apply one (1) complete shop coat of metal primer and paint to match exterior. Curries, Amweld 2600 or equal.

13. Hardware, Exterior Doors:

- a. Butt Hinges: Size and number per PC stockpile standards. Use solid brass or bronze butts for exterior doors, with set screw in barrel and ball bearing design. Hager or equal.
- b. Closures: Size and number as recommended by manufacturer per PC or stockpile.
- c. Lockset: Classroom and student restroom lever handle lockset, Schlage ND75PD, Tell LC2400 or equal. Staff restroom lockset, Schlage 85PD or Tell equal.
- d. Threshold: Threshold shall be PEMKO 271, Hager 413SA or comparable, 5" aluminum with PEMKO 216 AV, 783SAV or comparable equal, bottom door.
- e. Weather-stripping: All exterior doors shall be weather-stripped with Hager 891SAV or equal, at door jambs and head.

14. Entry Landing and Ramp (at raised wood foundation units): Each module shall have a landing(s) and ramp(s) to conform to Title 24 CAC Section 2-3307. The landing(s) structure including handrail and wheel guides is to be prefabricated metal in sections that are demountable for moving and reinstallation at a new site. There shall be sufficient cross bracing under the ramp surface to prevent bounce or oil canning of the ramp surface. Design shall such that the building contractor can make height adjustments at the installation site. The base bid ramp shall be no more than 4 feet wide and 11 feet long and have a 5' x 7' landing. The district will be responsible for the transition at the toe of the ramp to final finish grade.

- a. All ramps and landings shall have a metal surface with a nonskid finish applied. All metal ramp surfaces shall be painted as indicated in Section 3.3.19. Ramps shall have handrails per approved drawings and shall extend beyond the toe of the ramp as required by DSA. Wall mounted handrails shall be of similar construction to the integral ramp handrail. Foundation members shall be as for building foundation. Only the foundation pad resting on grade may extend beyond the outside face of the skirt 1" maximum.

15. Interior Wall Finish: Reference Brand: Vinyl Covered Tack board as manufactured by Domtar, Gypsum America, Inc. or Chatfield-Clark or equal.

- a. At Classroom: All interior walls shall be vinyl covered tack board applied in one continuous length from floor to ceiling. Tack board backing shall be applied over 1/2" sheetrock. The vinyl coating shall weigh a minimum of 8 ounces per square yard. The vinyl wall-covered panel shall have a Class I flame spread rating.
 - b. At Restroom Buildings (rooms): All interior walls shall be finished with FRP or equivalent to the ceiling over a water resistant gypsum wallboard.
16. Suspended Acoustical Ceiling and Acoustical Panels: Ceilings that support light fixtures or grills shall have a minimum classification of Heavy Duty per ASTM C635-07. Grid shall be direct hung in strict accordance with Title 21 CAC and Title 24 CAC and IR No. 47-4 issued by DSA and/or per DSA's approved PC/stockpile. Acoustical panels shall be 5/8" minimum thick mineral fiberboard or vinyl-faced fiberglass lay in panels, square edge, ASTM flame spread index Class C.
17. Lighting: The Contractor shall furnish a fluorescent lighting system or equal with overall illumination at desk level (30" above the floor) of an average of 50-foot candles. The maximum brightness of lighting sources at time of installation shall not exceed 50-foot lamberts. Night lighting shall be provided at exit(s), with internal photocell as provided in PC/stockpile.
18. Electrical: Provide 110/220 volt single phase service with one 100 amp panel box with nipple out per classroom. Provide panel schedule with electrical load calculations on drawings. Six (6) duplex convenience outlets grounding type shall be provided in each two-module classroom. Additional modules shall have two (2) outlets, one (1) at each end wall. Four outlets maximum per circuit shall be allowed. All receptacles to be 20 amp 120 volt two pole 3 wire commercial grade ivory. Owner to provide meter, grounding and hookup.
- a. A 12" diameter electric wall clock shall be installed in the classroom building near the center of the rear wall approximately seven (7) feet above the floor.
 - b. Light switches shall be Hubbell specification grade or equal.
 - c. All material and equipment to be used shall be new and shall comply with

requirements of either the National Electric Code or California Electric Code and the Title 24.

- d. All electrical wiring 110 V and greater shall be in conduit systems and shall meet or exceed the requirements of NEC minimum size conduit 1/2".
- e. Acceptable Conduit: Electrical metallic tubing (EMT); galvanized thin wall. Flex (Interior); galvanized steel. Flex (Exterior); galvanized steel with factory-applied PVC jacket.
- f. Wiring shall be No. 12 minimum copper type TW, THW, THHN, or THWN, stranded or solid as applicable. Conduit fill shall not exceed requirements of T-24, Part 3. A separate green grounding conductor shall be pulled throughout the entire system. Take care to avoid damage to wire or insulation during pull-in. Use powdered soapstone or a pulling compound such as "Yellow 77" lubricant, if necessary.

19. **Windows:** Provide 8040 anodized aluminum frame window units in opposite walls. Window frame shall be the fifty percent (50%) double sliding sash type (XOX); Windows shall not be mounted to the exterior plywood surface. All operable sashes shall have screens and positive locks. All operable windows will be provided with screens.

- a. Glazing specifications:
 - i. U Factor = 0.510 (Max)
 - ii. SHGC = 0.360 (Max)
 - iii. VT= 0.50 (Min)

20. **Painting:** All exposed surfaces shall be painted except aluminum window frames and thresholds. Material shall be of the grade specified or equal.

- a. Exterior - Wood siding, trim and skirting -Semi-Gloss latex: Apply one primer coat and at least one finish coat. Prime coat shall be brushed on or sprayed and back brushed into all grooves in the siding as needed. If necessary, in the opinion of the inspector, an extra coat shall be applied to all grooves so that the finish coat will have a uniform appearance. Allow prime coat to dry according to manufacturer's recommendation. The district will select color after award of the bid from paint manufacturer's standard colors.

- i. Semi-Gloss Trim: per manufacture standard

- ii. Semi-Gloss Body: per manufacture standard
- b. Interior Trim - All trim not pre-coated shall be painted with two (2) coats of semi-gloss latex over prime Coat.
 - i. Semi-Gloss trim: per manufacture standard
- c. Metal - All metal surfaces shall be painted with two (2) coats of alkyd-finish coat.
 - i. Gloss Trim and Door: per manufacture standard
- d. Exterior - Cement Plaster: per the 2016 California Building Code: Section 2512.8
ALTERNATE METHOD OF APPLICATION, including Section 2512.8.2 CURING

21. **Flooring and Accessories:**

- a. Carpeting: All classroom buildings have the upgrade option to be carpeted with Tandus Powerbond Cushion RS, "Color Spectrum" in main area and a minimum of a 6' x 6' walk off area at exit doors with Tandus Powerbond Cushion RS "Abrasive Action" or equal. Color to be selected by the District after award of the bid.
 - b. Resilient Sheet Vinyl: All restroom buildings shall have Armstrong "Classic" vinyl Carlon, or equal. Install per manufacturer's instructions. Noted sheet vinyl is the minimum standard of quality acceptable and, if used, shall be provided with integral 6" minimum cove base. Single occupancy restroom with 2 fixtures or less the vinyl shall be laid flat with 6" resilient top set base.
 - c. Resilient Top set Cove Base: Best quality, molded rubber, 1/8" thick, 4" high, molded top-set cove. Solid color as manufactured by Burke Rubber Co. No. 502-P or comparable.
 - d. Adhesives: As recommended by floor covering and base manufacturer. Furnish and apply per manufacturers written instructions. Shall be non-toxic and water based.
22. **Insulation:** Wall insulation shall have a rating of R-13 at 2 x 4 walls, floor insulation shall have a rating of R-19, and ceiling insulation shall have a rating of R-30. R-13 rated insulation shall be provided in all interior wall cavities.
23. **Heating, Ventilation and Air Conditioning:** At the restroom building, the contractor shall provide power ventilation. At the classroom building, the contractor shall provide a

HVAC heat pump that is tested and approved per manufacture standard. The Heat Pump(s) are to be all electric wall mounted blow-through single zone unit with housing, outside air intake hood with volume damper, indoor fan direct drive, Freon 22 hermetic compressor with crankcase heater, indoor coil, outdoor fan, outdoor coil, controls, mounting brackets and thermostat with auto changeover. All return air is direct to the air handler.

- a. Heat pump(s) shall be factory assembled, piped, wired, and tested operating refrigerant charge. Unit shall be UL and C.E.C. listed. Heat pump unit(s) shall be suitable for outdoor installation. Filters shall be UL Listed Class 2 throwaway type (SFM listing 3175-140:006) and shall have 25% efficiency based on ASHRAE Test Standard 52-76. (Standard of quality shall be Farr 30/30 or approved equal. Reference brands Marv Air or comparable)
- b. All units shall be 230/208 volt, single phase system, UL approved or comparable and meet current energy standards.
- c. The system shall maintain an automatically controlled indoor classroom temperature of 78 degrees F in summer and 68 degrees in winter with a 45 percent relative humidity when the outdoor dry bulb temperature of 66 degrees F average. The systems must maintain the above temperatures when the damper is adjusted to use 15 CFM per occupant of outside air.
- d. Heat pump units shall be sized according to the attached floor plans and per manufacture standard, Manufacturer may in accessible concealed portions of duct system use either rigid 1" fiberglass or insulated "Flex duct" with vapor barrier. All ductwork within 2' of the HVAC unit and all interface connections shall be metal Ductwork and reinforcement shall be designed for .3 inches static pressure.
- e. Registers and Diffusers: Provide four-way throw air diffusers per manufacture/PC stockpile standard and approved drawings.
- f. Thermostat: Provide electronic programmable thermostat with occupant override. White Rodgers IF-95 or equal is required. Thermostat shall have the following functions:
 - i. Five (5) and two (2) weekday/weekend programming with four (4) separate time/temperature settings per 24 hour period.

- ii. Keyboard lockout switch.
 - iii. Programmable display.
 - iv. Two-hour override minimum.
 - v. Status-indicated LEDs.
 - vi. Battery backup. Thermostat
- g. Calculations shall be based on an occupancy for 24'x40' building of forty-eight (48) occupants and an interior space of approximately 9,000 cubic feet. Calculations shall be modified accordingly with increase in size of building. The mechanical ventilation system shall provide a required rate = 15 CFM/occupant.
- h. Manufacturer's literature, operating instructions and guarantee shall be delivered to the school office at the time the building is delivered.
- i. Units shall be installed in strict accordance with manufacturer's instructions with particular attention to required flashing.
24. Plumbing Fixtures and Trim – Restroom Building: Fixture count and type per bid document floor plans and per DSA approved manufacture's PC or existing stockpile.
- a. Angle stops shall be 'A" Brasscraft SCR-19, lock-shield, loose key or equal.
 - b. Water Closet: Kohler K-4405 or wellworthK-4408 (floor mounted), Sloan Regal 111-YB flush valve, and Olsonite OCC white open-front seat or equals.
 - c. Lavatory: Kohler "Hudson" china only with Chicago faucet 333-E2805-665PSHAB push button single punch or Chicago faucet 3300-ABCP (ADA) 4" with wall brackets or equal. As a minimum provide: 2 each in Boys & girls @ restroom units.
 - d. Urinal (restroom unit only); Kohler "Dexter" K-5016-ET-O, wall mounted, Sloan Royal flush valve. As a minimum provide: Boys - One (1) handicap and one (1) non-handicap.
 - e. Toilet Partitions and Urinal Screen; Enameled steel toilet compartments, floor mounted, overhead braced.
 - f. Stainless Steel Handicapped Compliance Grab Bars: Two per each enclosure.
 - g. Mirror; 18"x36" Stainless steel mirror, JS #100 or equal, one (1) for each lavatory.
25. Fire Alarm: Contractor shall install exterior-accessed single gang junction box at rear of building (near the electrical distribution panel) with 3/4" conduit stubbed up wall to above

ceiling for future connection, which is not part of the base bid and can be added by change order. Contractor shall also install 3/4" conduit from fire alarm pull station junction box mounted near the front exit door, up to (1) exterior horn box, (1) interior horn/strobe box, (2) ceiling mounted smoke detector boxes, and (1) attic mounted heat detector box, accordingly, also for future connection. Wiring, devices, programming and additional conduit are not part of the base bid, but can be added by change order. A weatherproof metal plate will cover all exterior boxes. Horn/strobe box shall be mounted near the doorway area at 80" above finished floor/grade.

26. Fire Extinguishers: Each portable classroom shall be equipped with a pressure-type fire extinguisher with 2A10BC UL rating, to be mounted on the interior wall of the building near the doorway at a height of four (4') feet, to handle. Fire extinguishers shall be totally charged and have a dial indicating the state of charge.

27. Marker Boards: Each classroom shall have two (2) each 4 x 8 marker boards installed side by side to make a 4 x 16 panel, centered on one (1) of the long walls. A full-length map rail shall be provided with cork inset and end stops. The map rail and chalk rail are to incorporate a channel to wrap around the panel. Three (3) map hooks with clips per panel shall be provided. One (1) flag holder, 1/2" size shall be provided for each classroom. Whiteboards shall be institutional quality prefabricated writing board with Panelyte Glossy "Dry Wipe" high pressure laminate.

28. Energy Conservation: Energy calculations shall be provided (if required) for building location and will comply with Title 24 CBC, Part 6 California Energy Code.

D. INSTALLATION ON SITE

1. Erection at Site: Once delivery of modules to the site is made, erection shall commence within forty-eight (48) hours and be pursued in a timely manner until complete. All modules called for at that site shall be scheduled for delivery and erection in one continuous time frame (Saturdays, Sundays, and holidays excluded.)

a. When the Contractor considers the Work complete, the Contractor shall notify the Architect and Inspector. Architect/Inspector shall provide Contractor within five (5)

days of Contractors request, a complete and final punch list. Contractor shall begin work within five (5) days of receipt of final punch list and completed within fifteen (15) days of the commencement of work. Contractor shall notify Architect/Inspector of punch list completion in writing and shall schedule a walk through and sign off of the building within five (5) days after notification. Upon Contractors completion of Punch List to the reasonable satisfaction of the Architect and Inspector, Contractor shall be considered complete. No additional Punch Lists may be created by the Architect or Inspector.

- b. Power shall be connected to the building (which is not part of the base bid and can be added by change order) within fifteen (15) days of installation or shall be deemed accepted by district.
- 2. Clean Up: Because of the nature of the sites, i.e., school grounds, the contractor shall lock up all materials and equipment at the end of the day's work. All scrap material shall be removed from the site at the end of each day's work. Toxic chemicals of any kind shall not be allowed on school grounds.
- 3. Utility Hook Up: All utility connections shall be located as indicated on site plans to accommodate hook-up at the site at the locations indicated on the plans. Utilities hook-up, which is not part of the base bid and can be added by change order. The District's Architect will provide the plan(s).
- 4. Grounding of Building Components: Bonding of all metal portions of the building for ground, i.e., frame, ramp, etc. is the responsibility of the contractor to the satisfaction of the site inspector. Grounding of total building, including ground rod, wire, connections, etc. shall be installed by the district and ready for testing, which is not part of the base bid and can be added by change order, in the presence of site inspector. Testing shall be conducted per IR No. 8-1 as issued by DSA.
- 5. Certification of Compliance: The Contractor will provide to the District for each building delivered, a letter or certification that said building was built and installed in compliance with the project's technical specification as well as with all local codes, laws, and regulations applicable to relocatable buildings.

END OF TECHNICAL SPECIFICATION

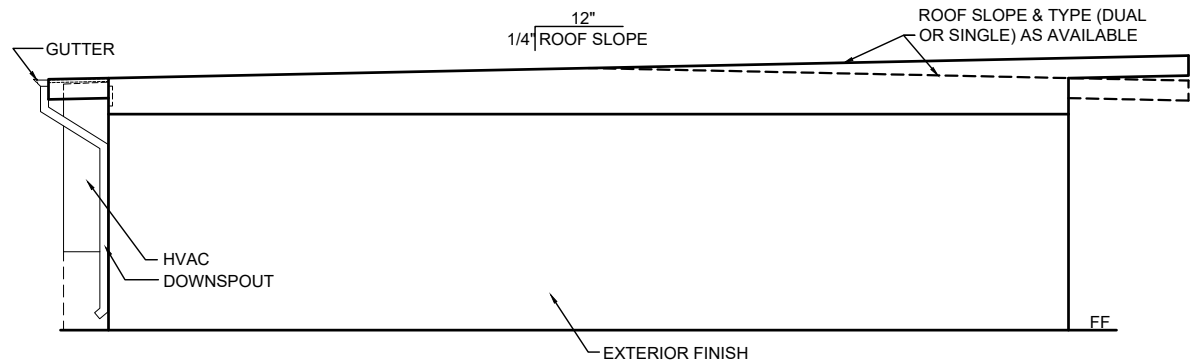
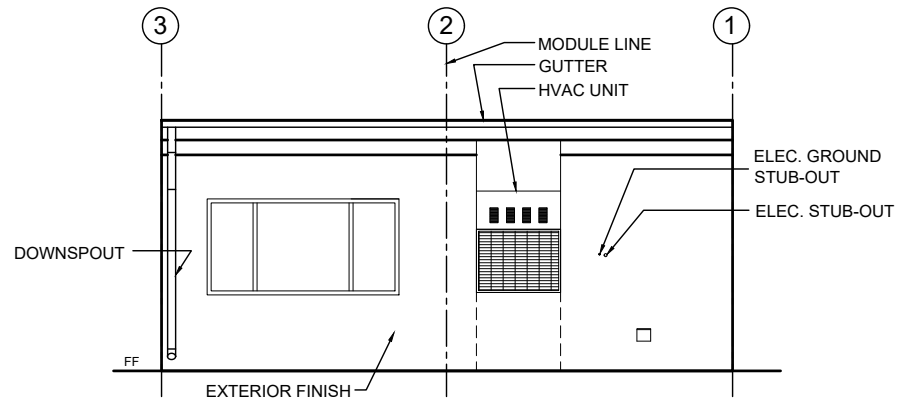
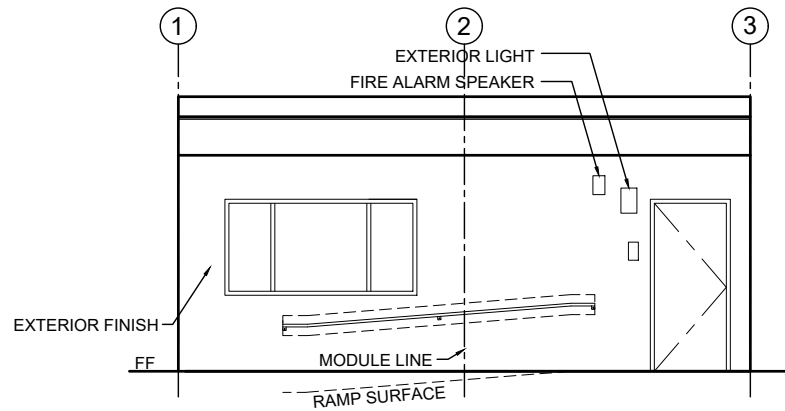
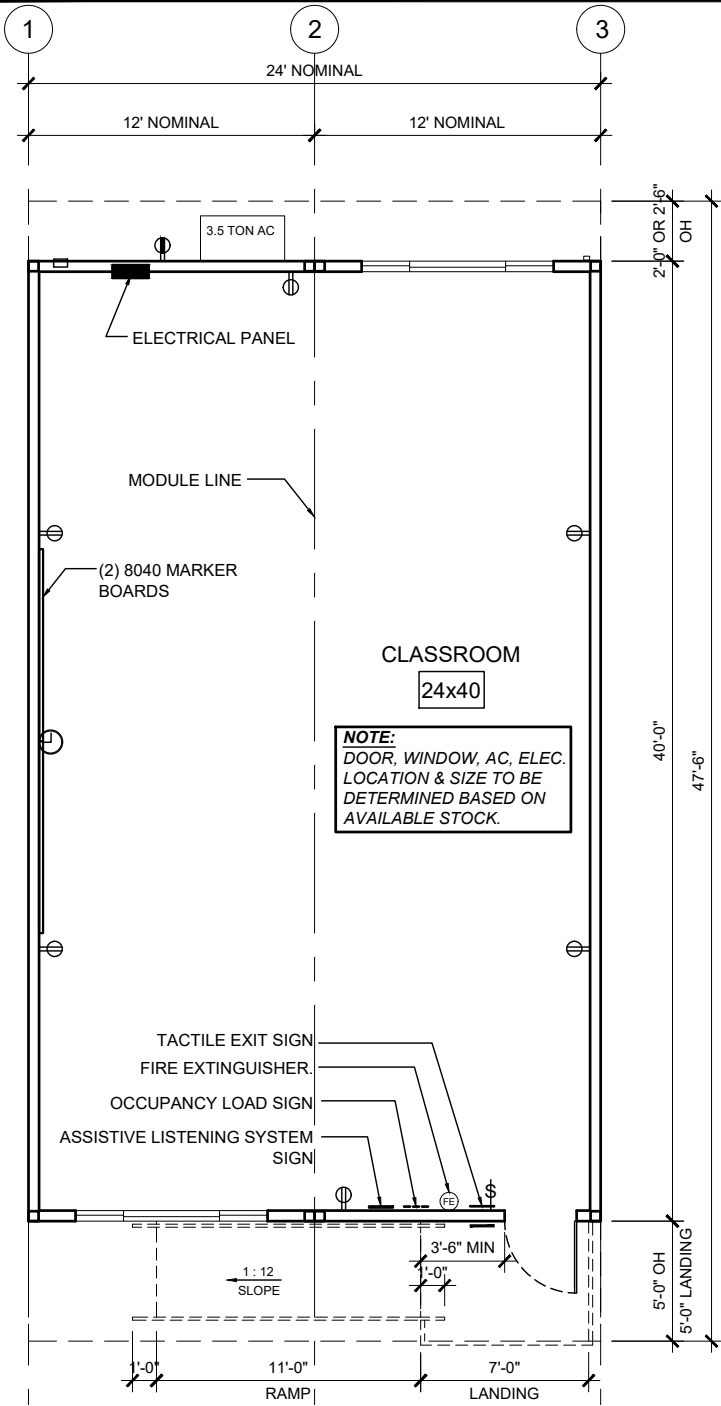

MODEL "A" 24x40 REFURBISHED CLASSROOM

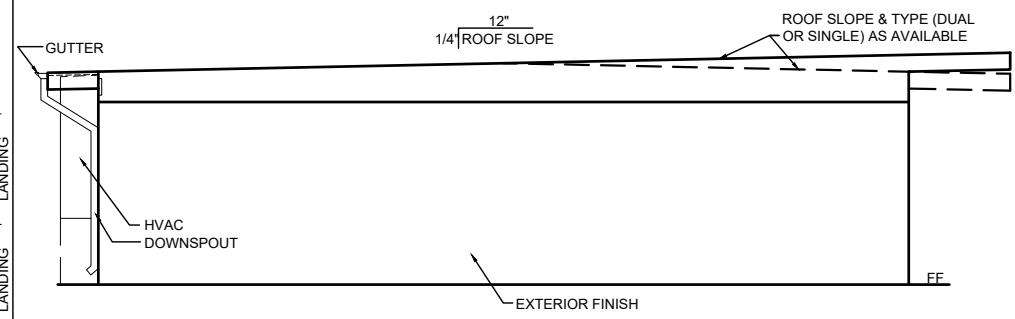
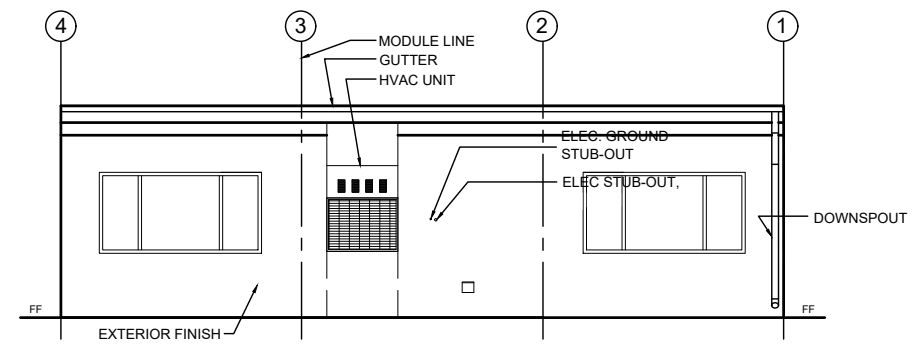
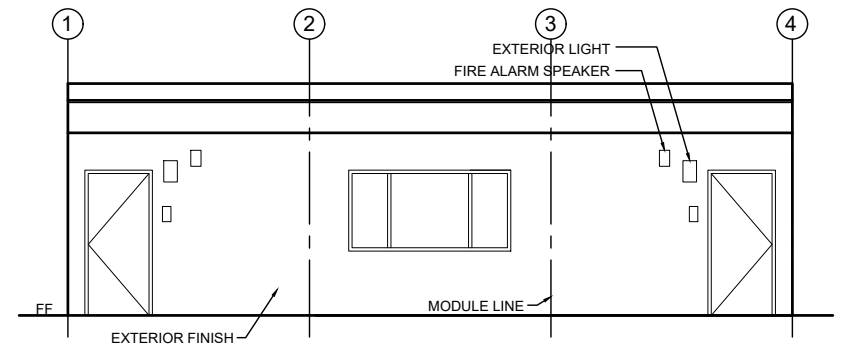
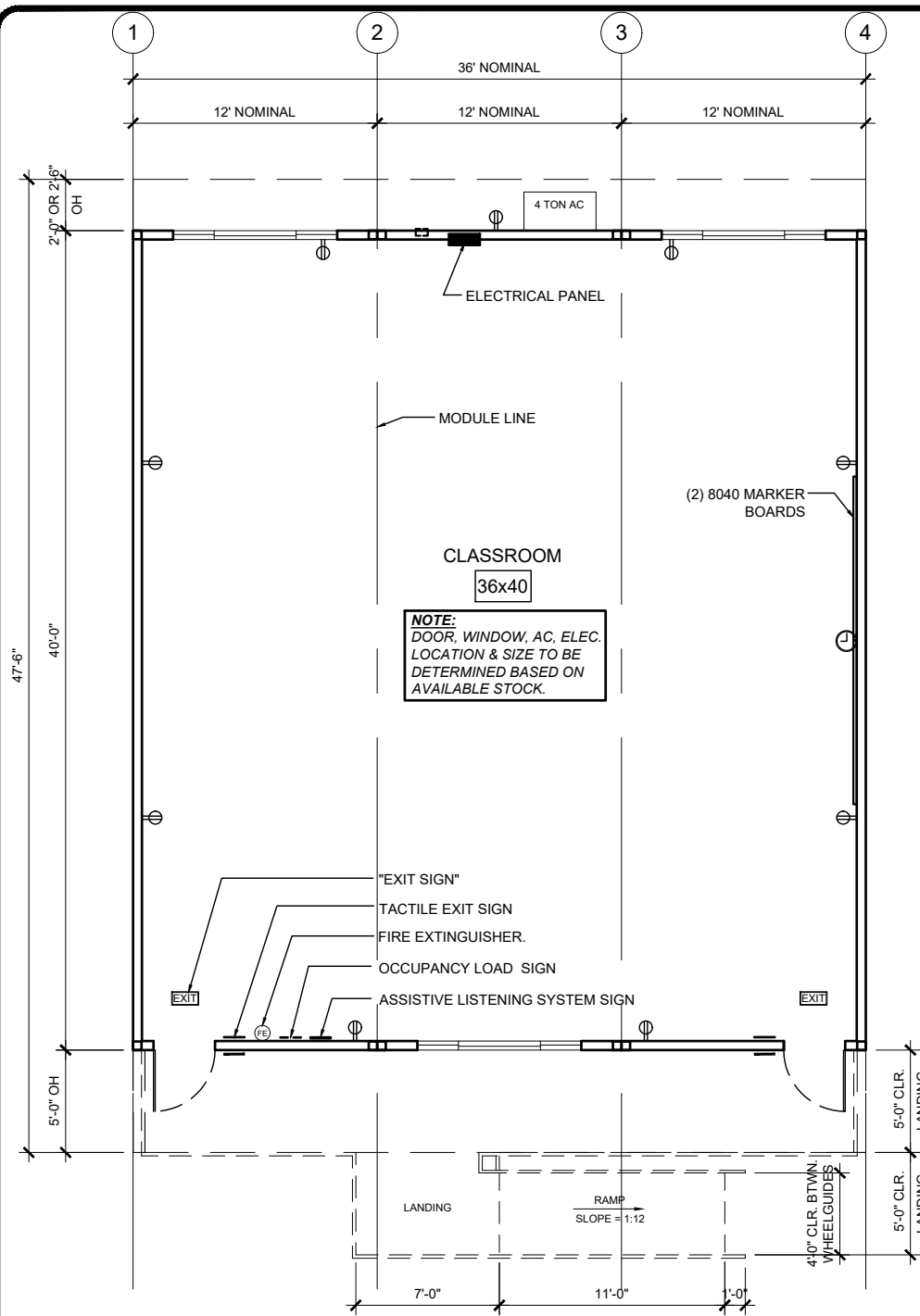

MODEL "B" 36x40 REFURBISHED CLASSROOM

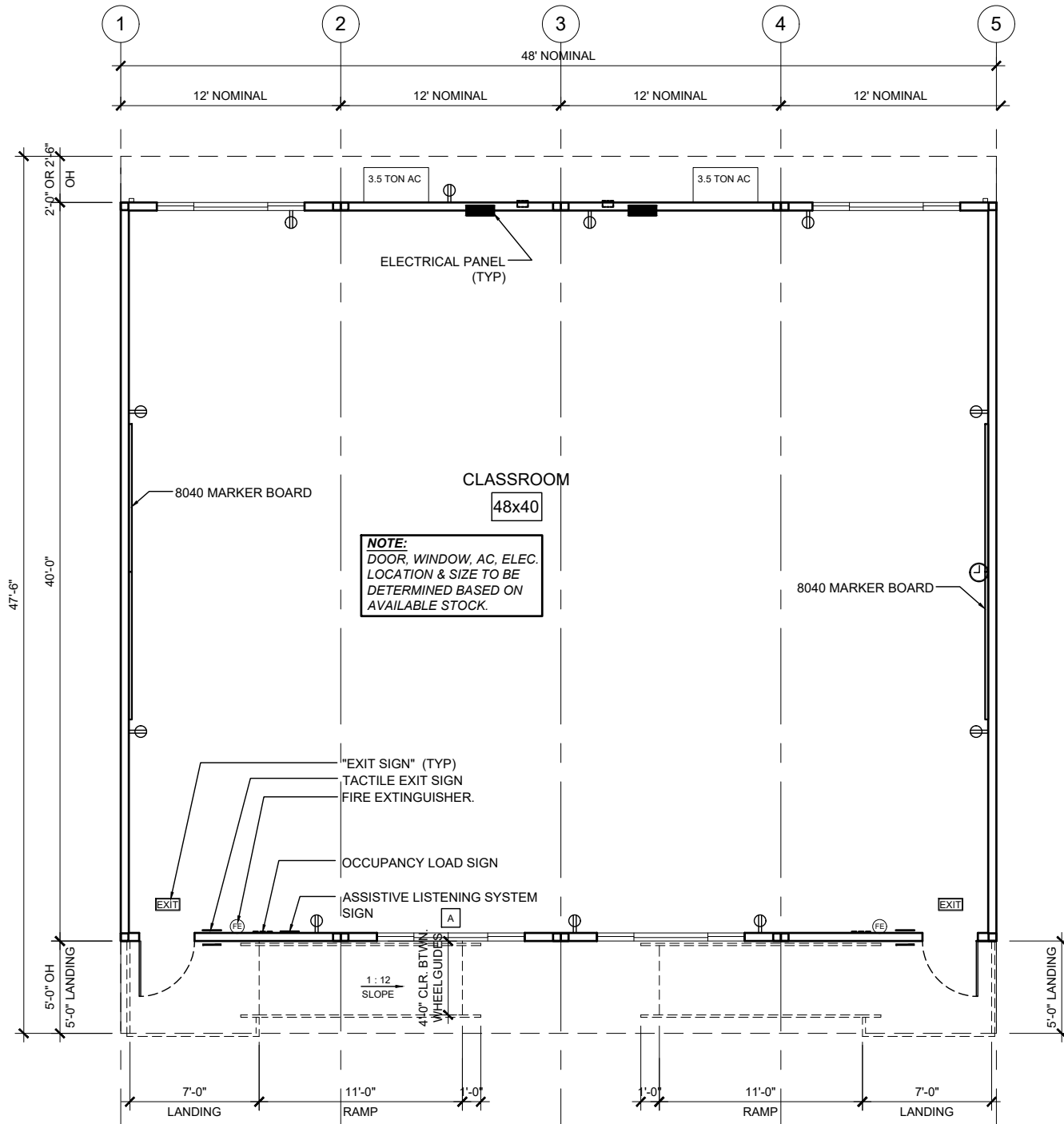

MODEL "C" 48x40 REFURBISHED CLASSROOM (FLOOR PLAN)

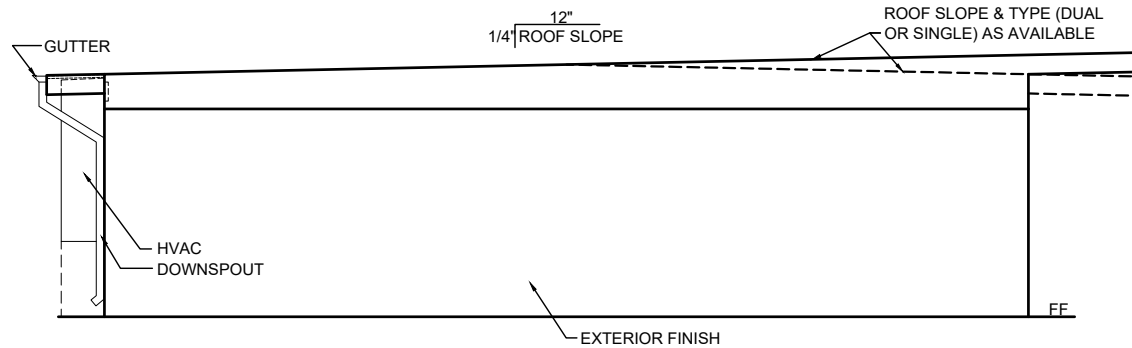
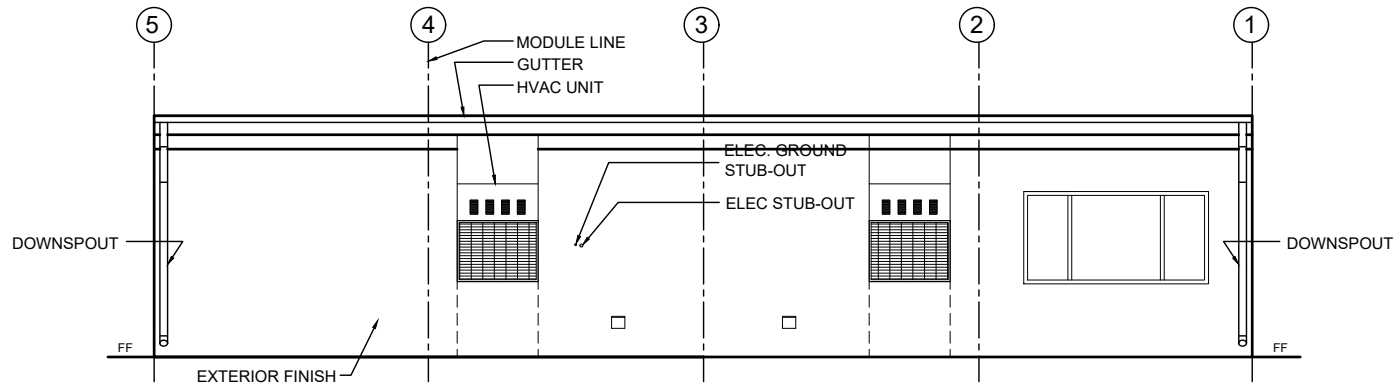
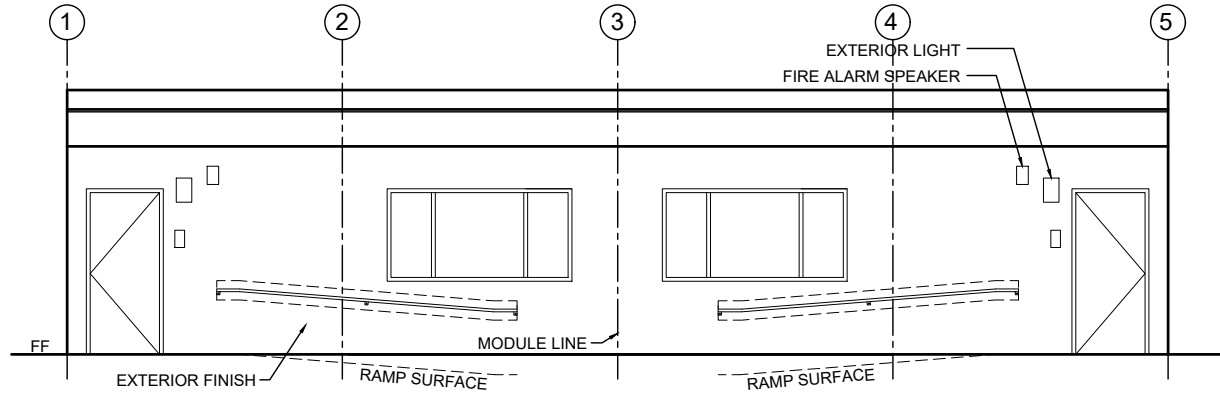

MODEL "C" 48x40 REFURBISHED CLASSROOM (EXT.ELEV.)

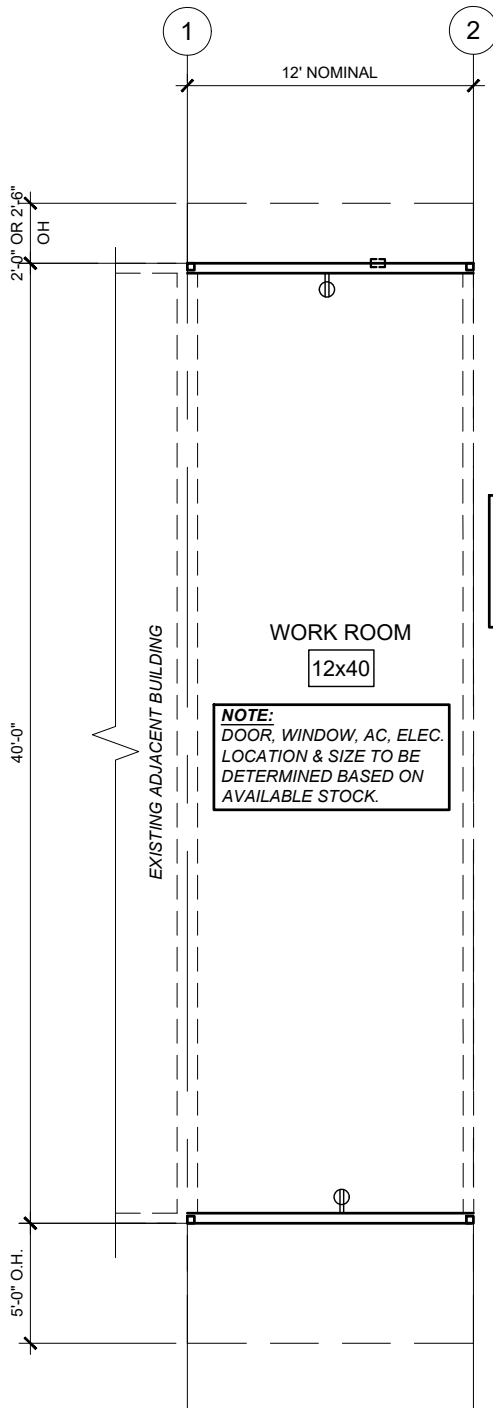

NOTE:
MODULE MAY BE
INSTALLED BETWEEN
EXISTING MODULES OR
AT THE END FOR
BUILDING EXPANSION

NOTE:
DOOR, WINDOW, AC, ELEC.
LOCATION & SIZE TO BE
DETERMINED BASED ON
AVAILABLE STOCK.

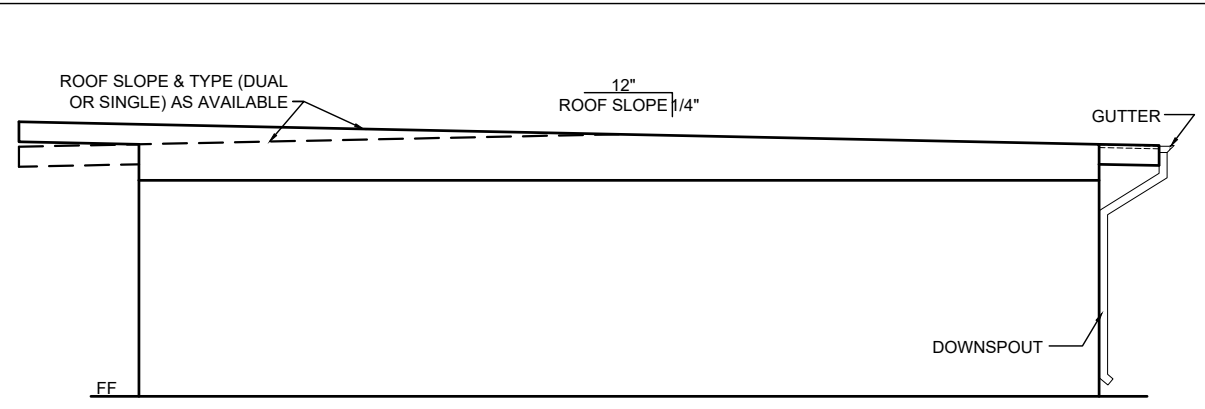
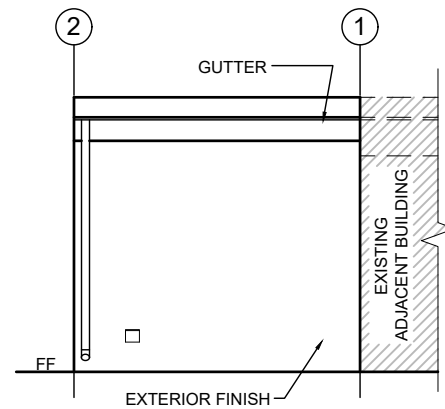
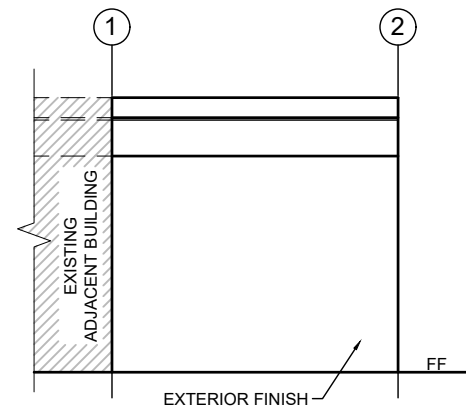

MODEL "D" 12x40 REFURBISHED ADD-ON MODULE

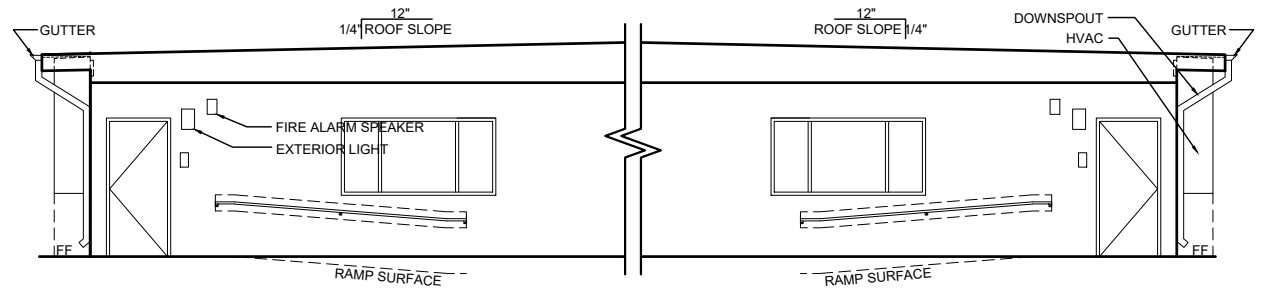
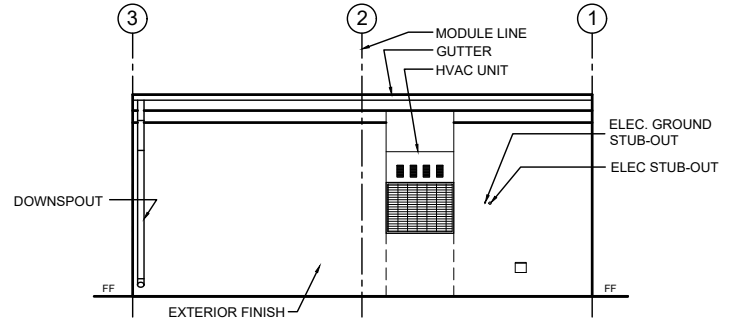
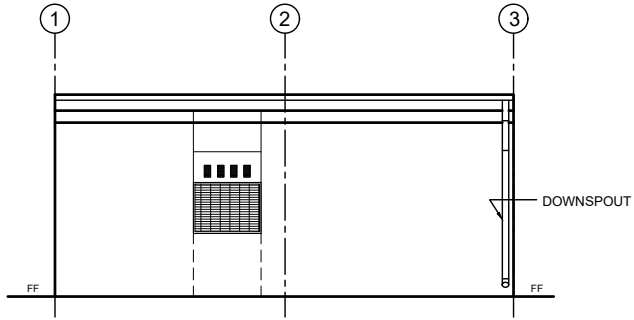
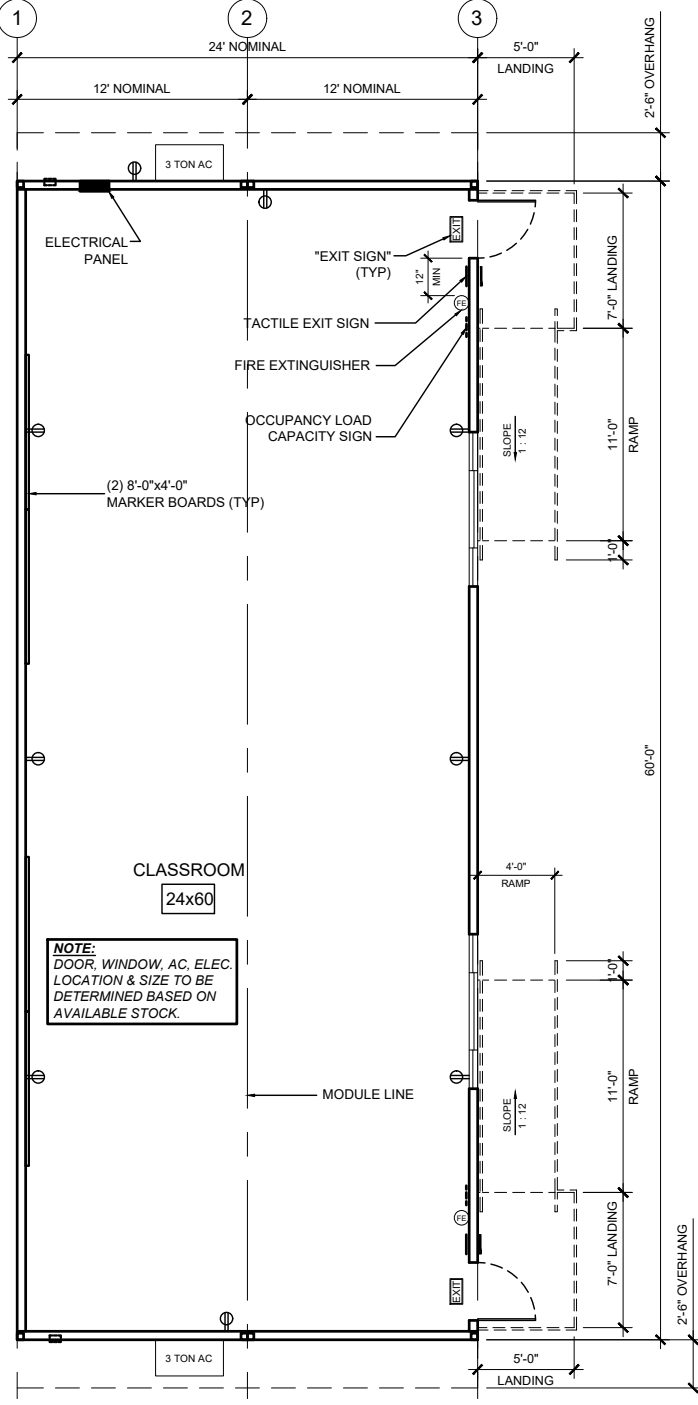

MODEL "E" 24x60 REFURBISHED CLASSROOM

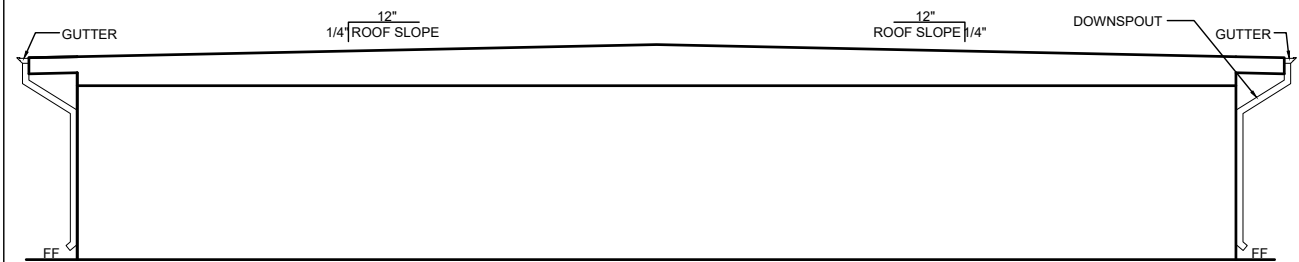
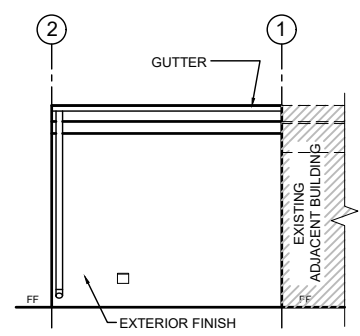
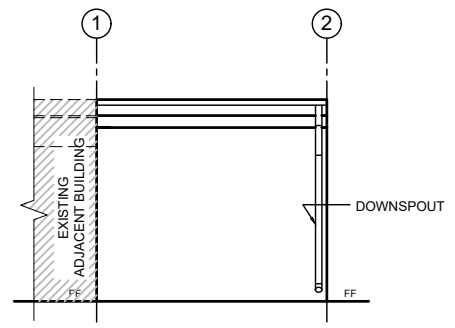
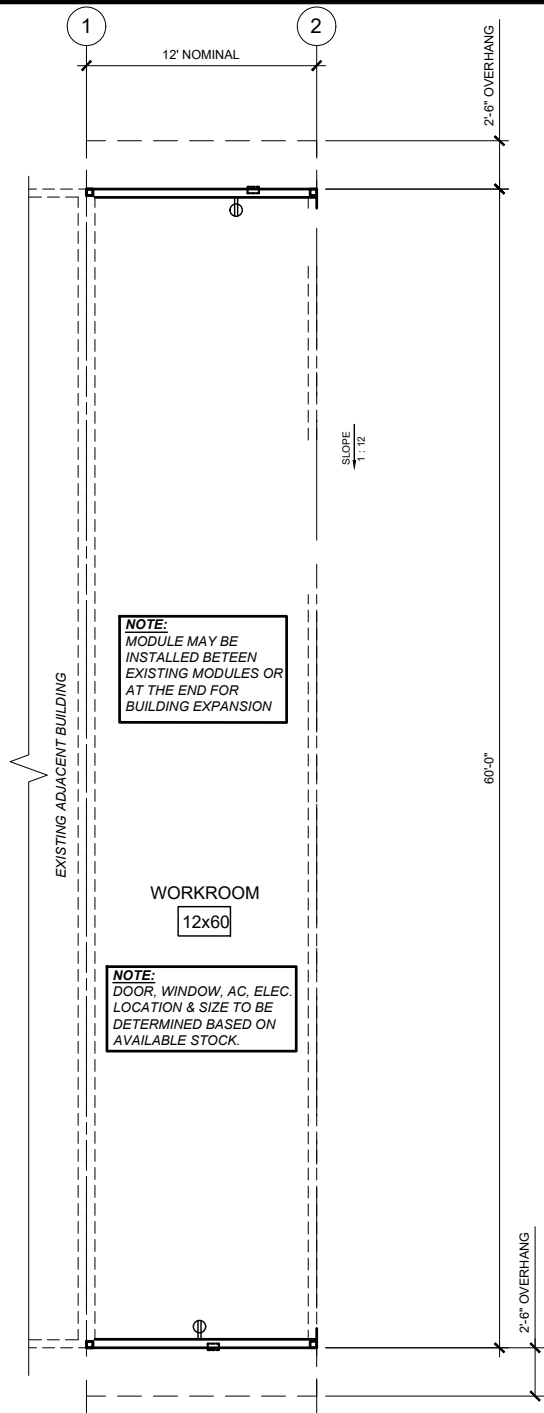

MODEL "F" 12x60 REFURBISHED ADD-ON MODULE

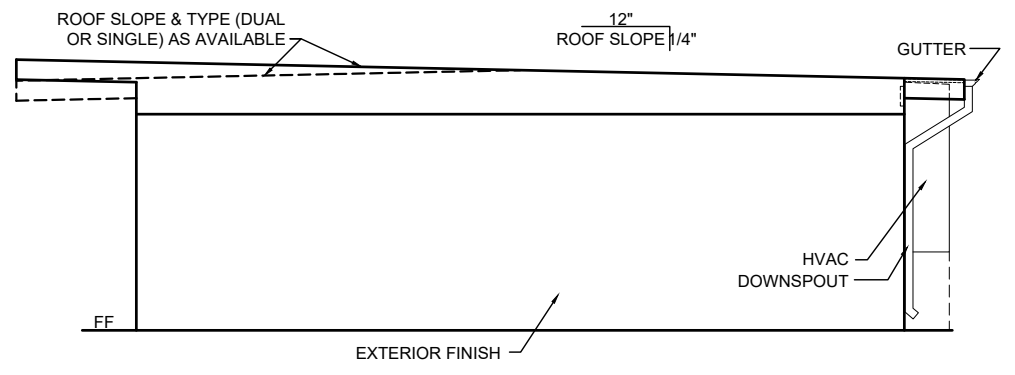
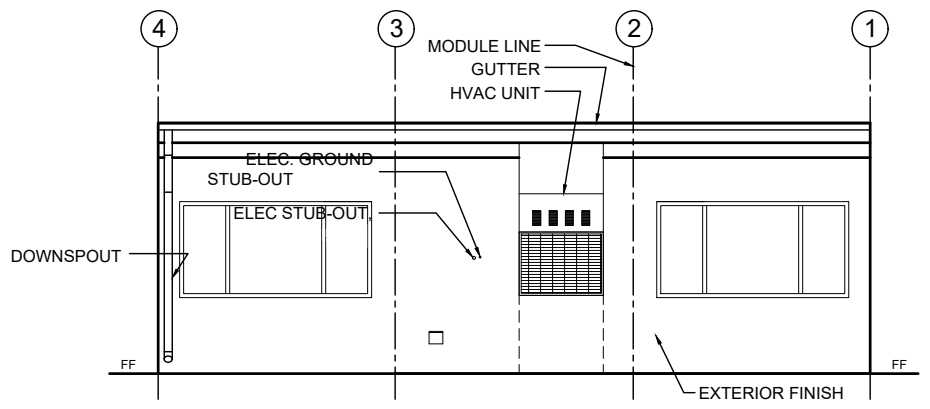
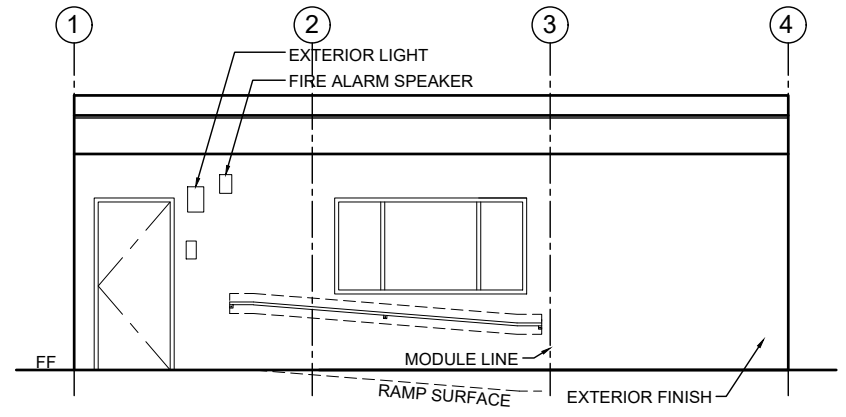
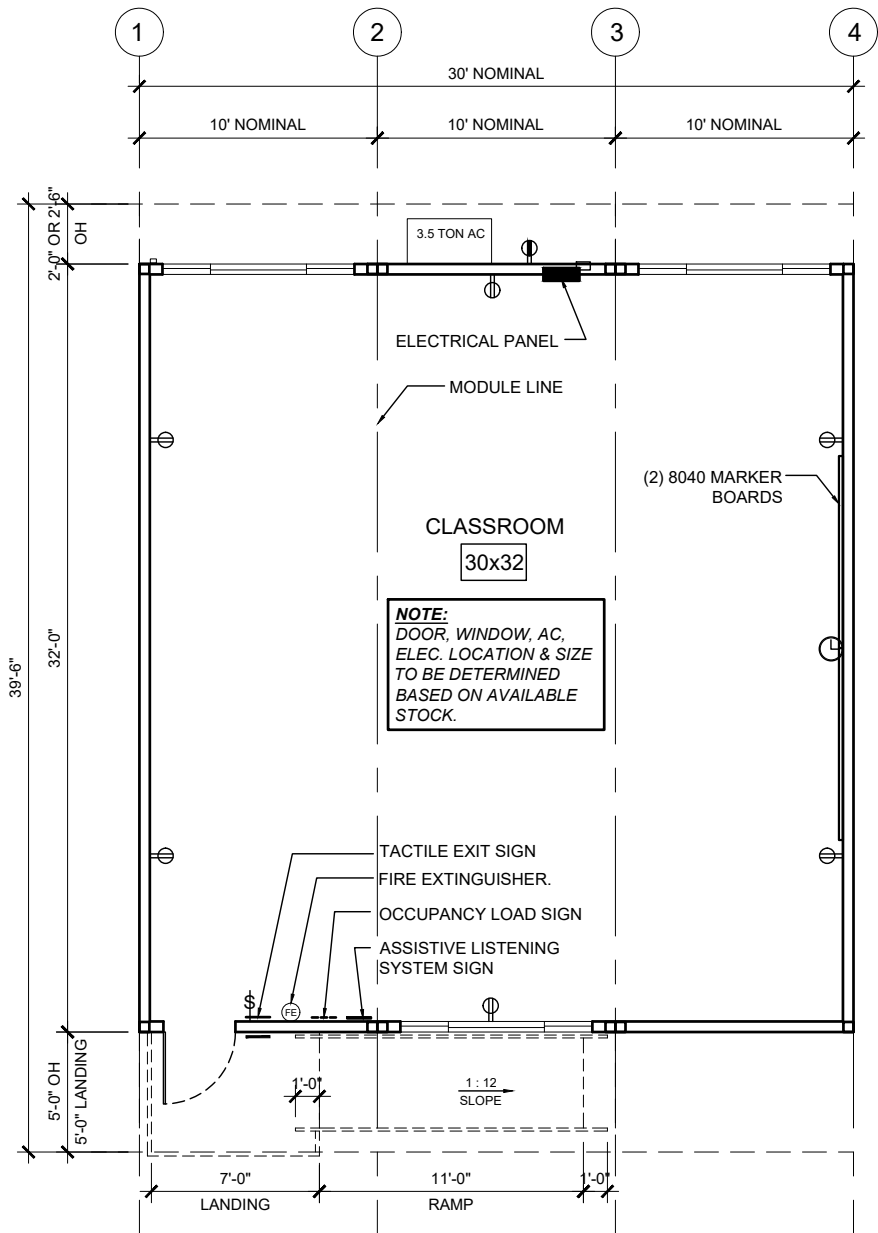

MODEL "G" 30x32 REFURBISHED CLASSROOM

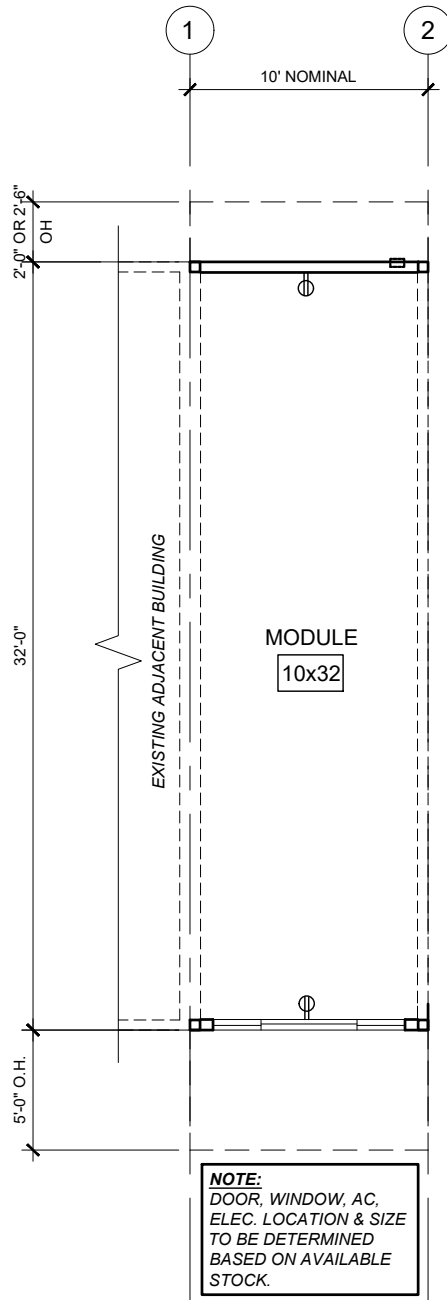

NOTE:
MODULE MAY BE
INSTALLED BETWEEN
EXISTING MODULES OR
AT THE END FOR
BUILDING EXPANSION

NOTE:
DOOR, WINDOW, AC,
ELEC. LOCATION & SIZE
TO BE DETERMINED
BASED ON AVAILABLE
STOCK.

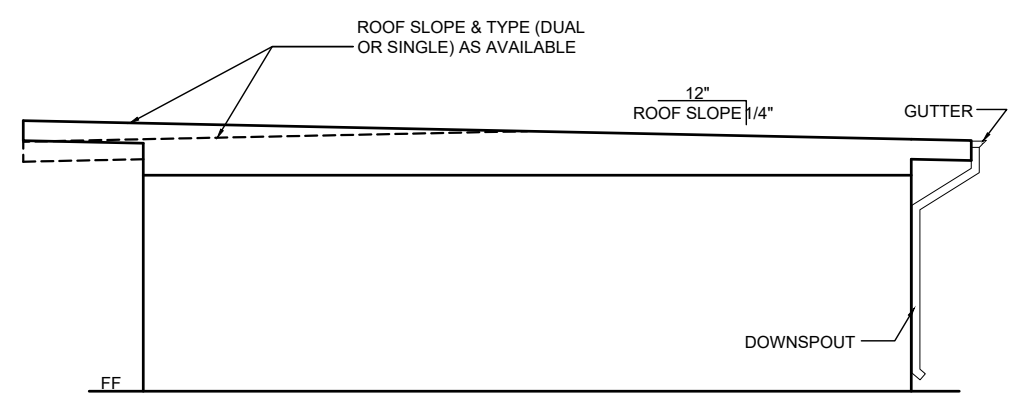
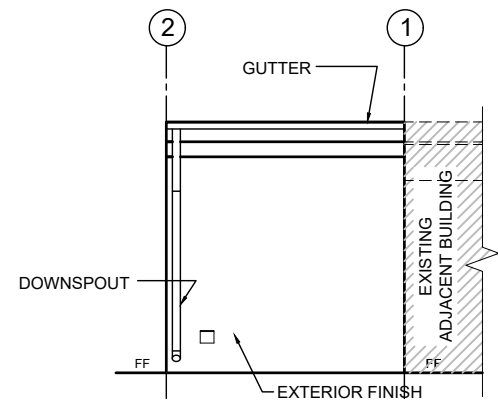
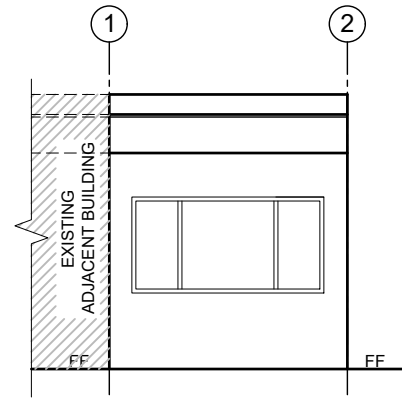

MODEL "H" 10x32 REFURBISHED ADD-ON MODULE

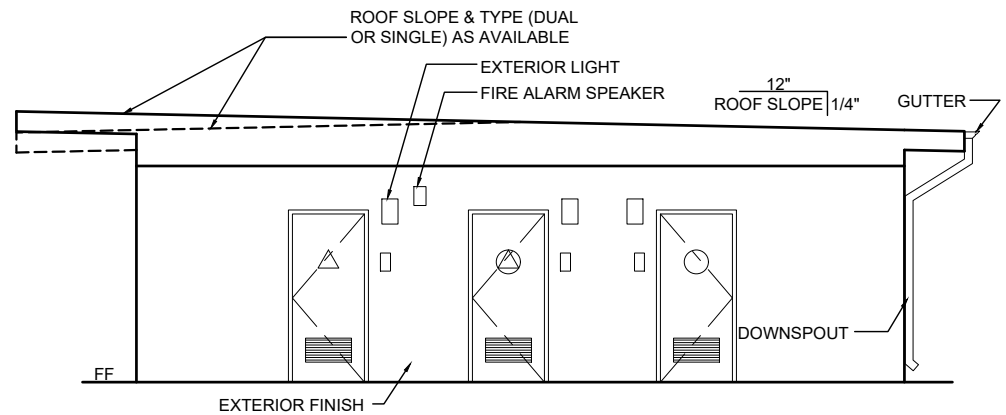
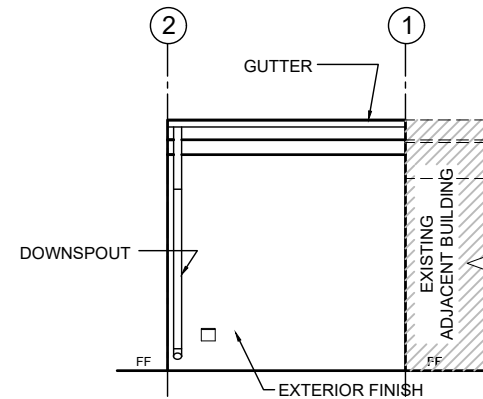
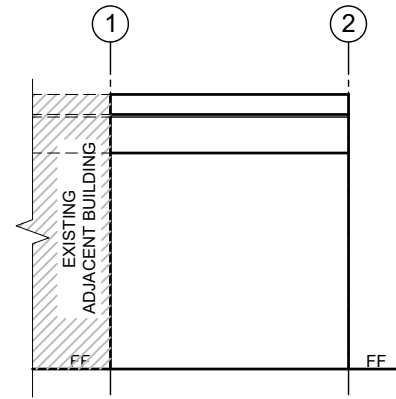
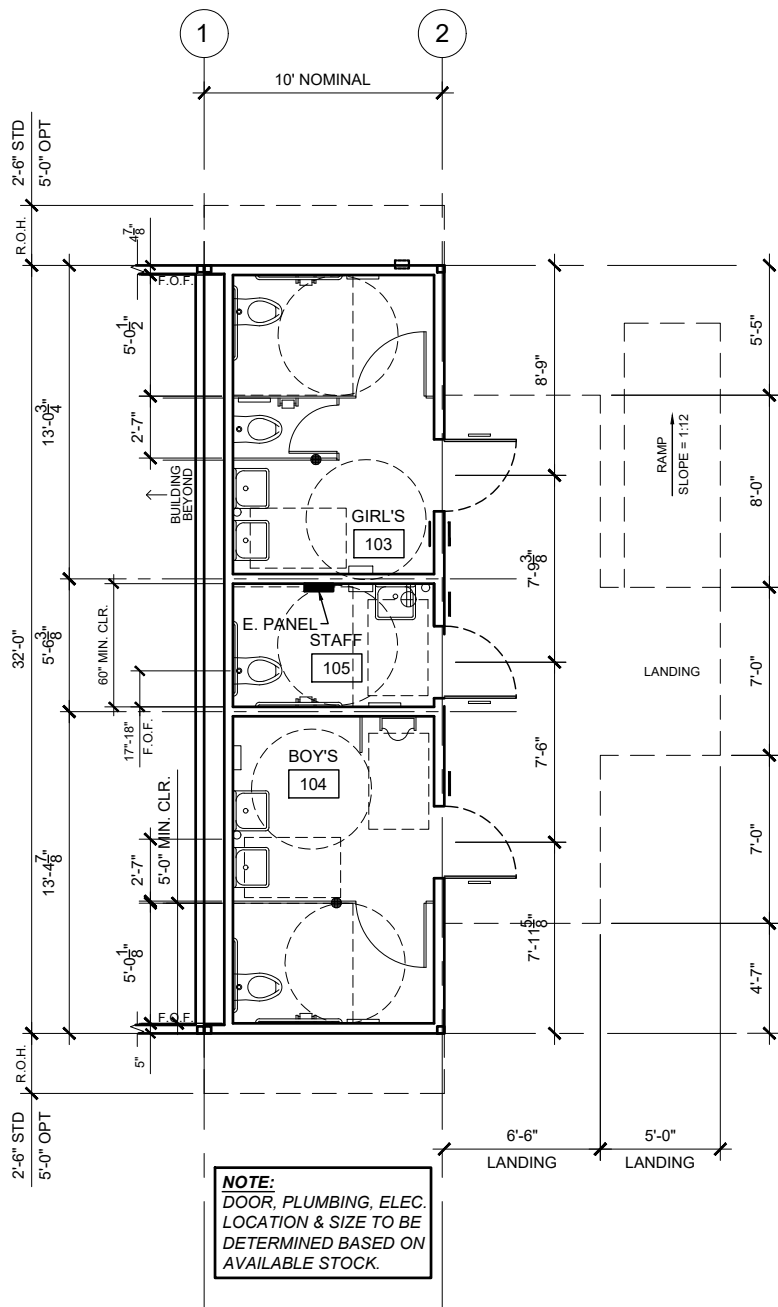

MODEL "I" 10x32 REFURBISHED RESTROOM MODULE

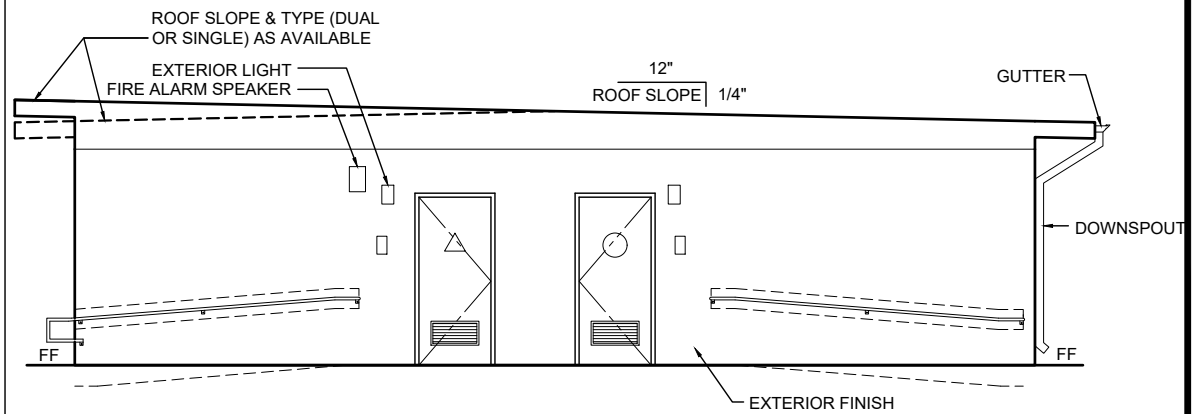
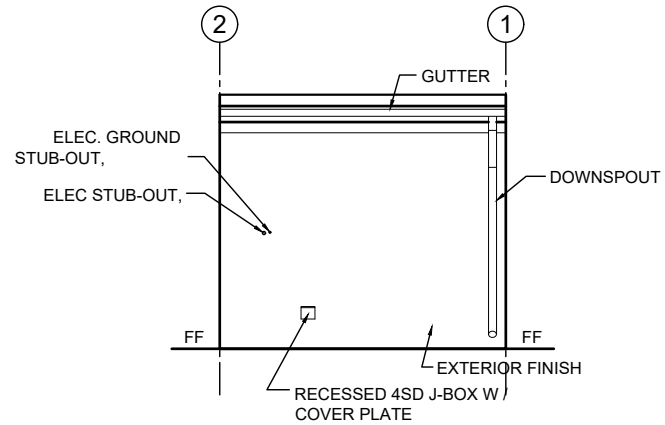
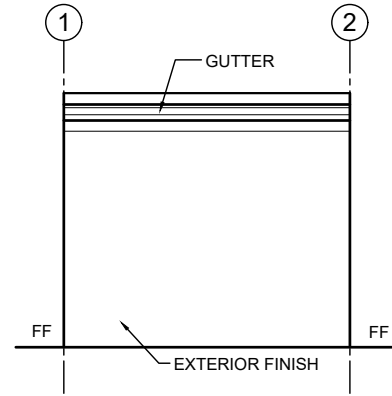
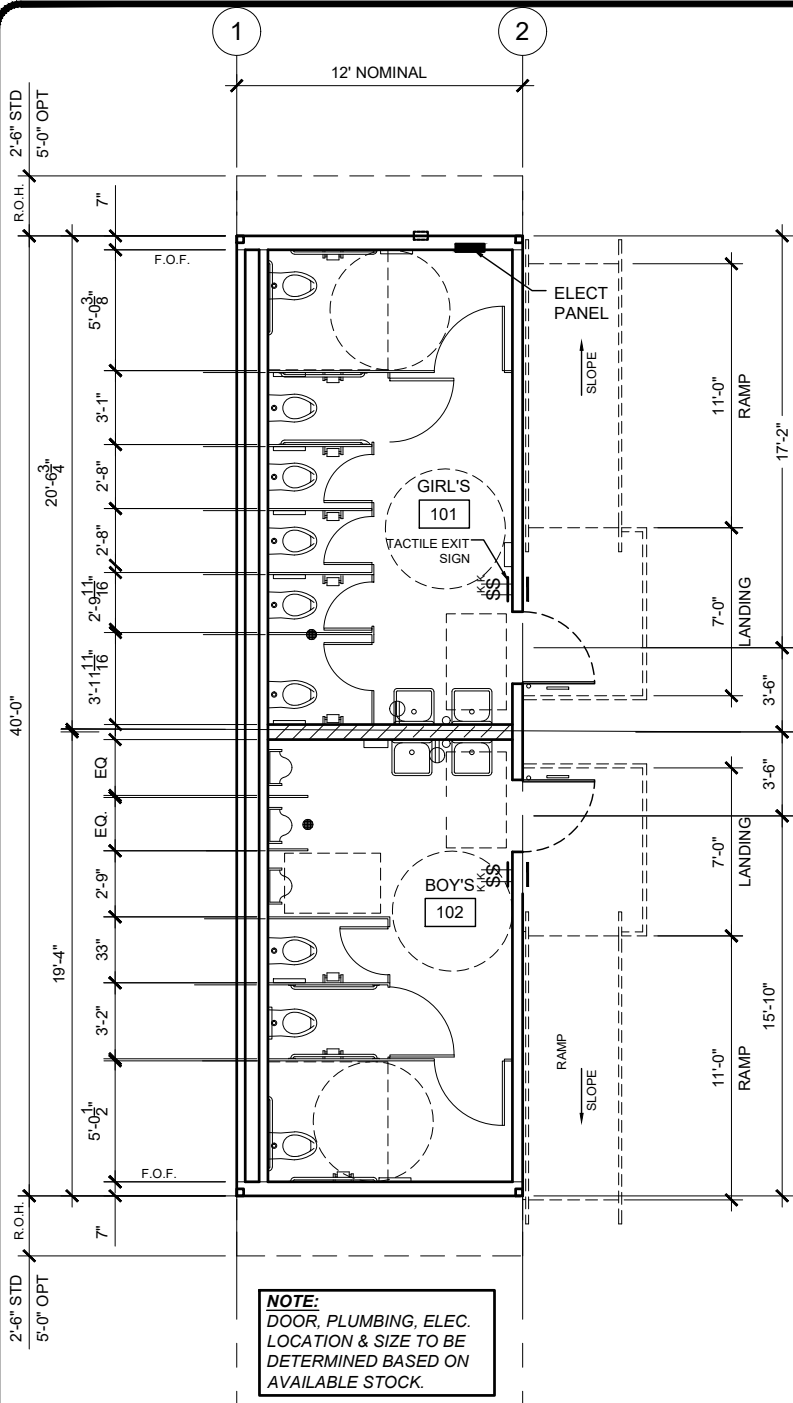

MODEL "J" 12x40 REFURBISHED RESTROOM B/G

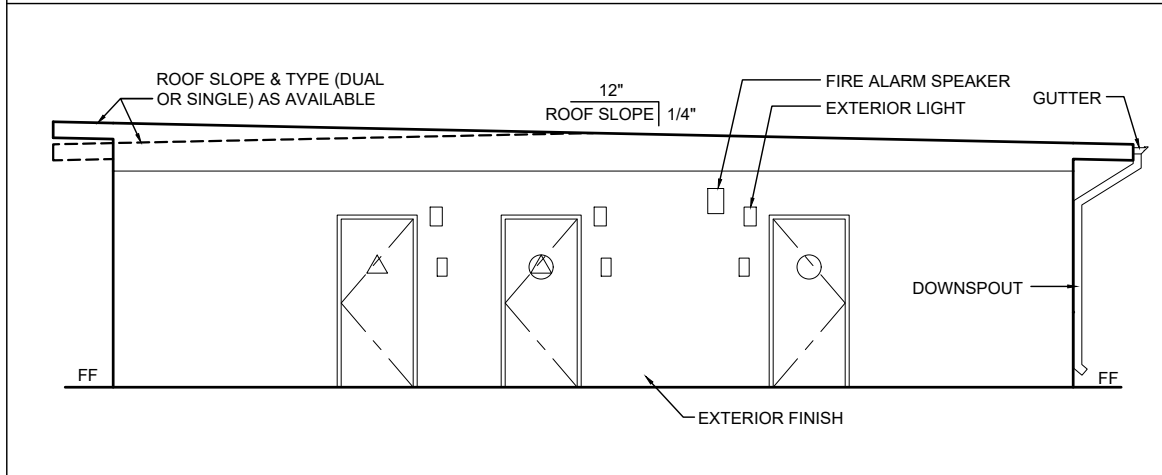
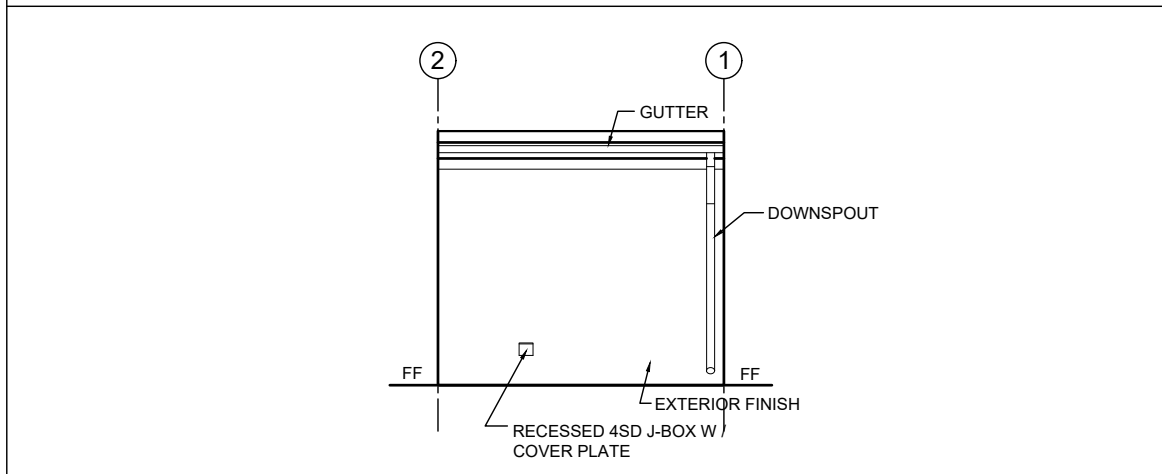
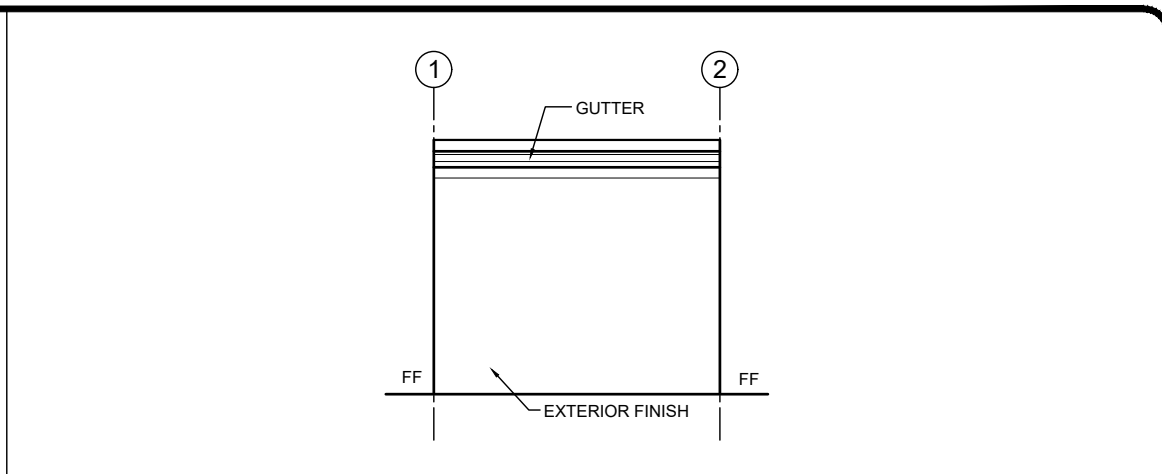
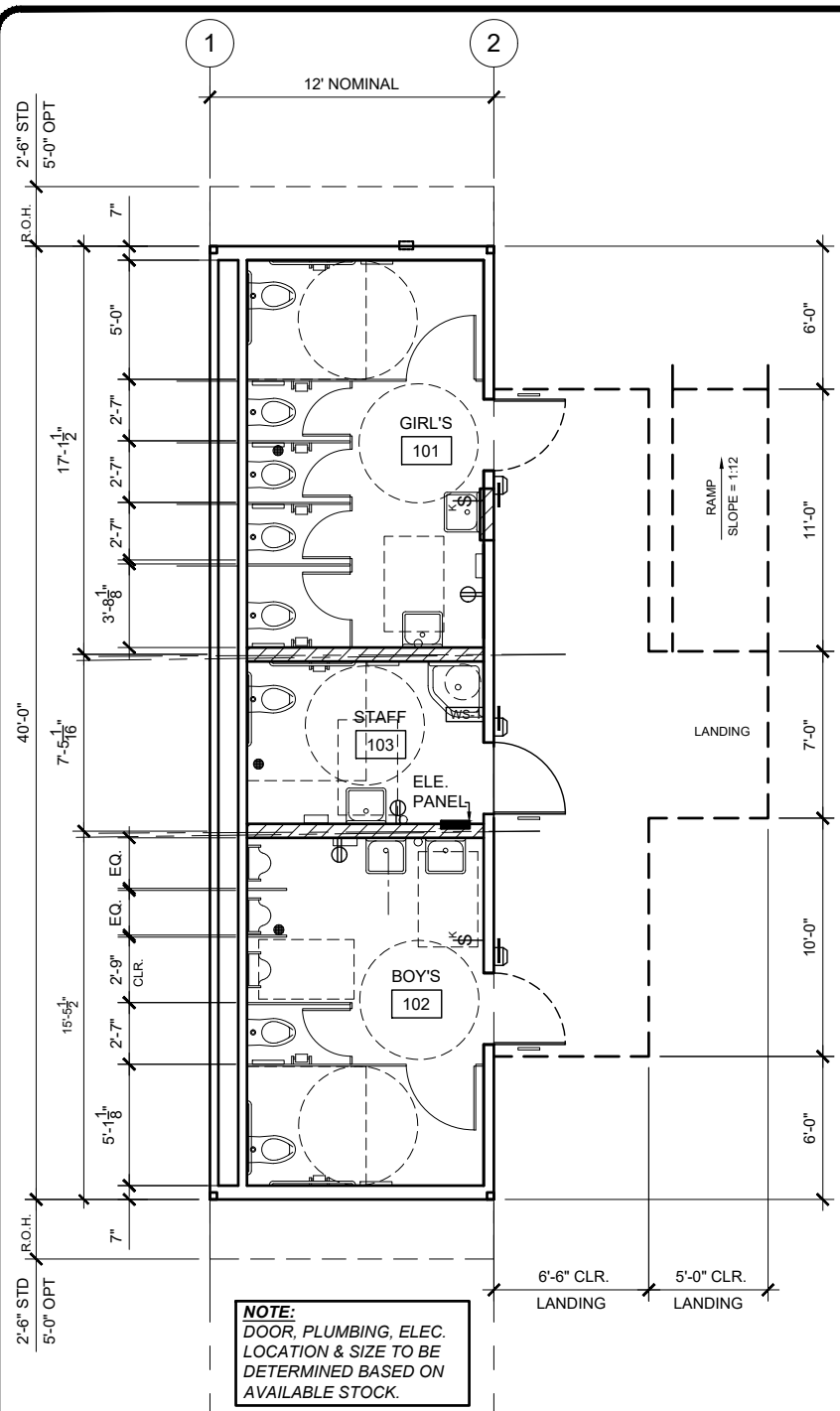

MODEL "K" 12x40 REFURBISHED RESTROOM B/S/G

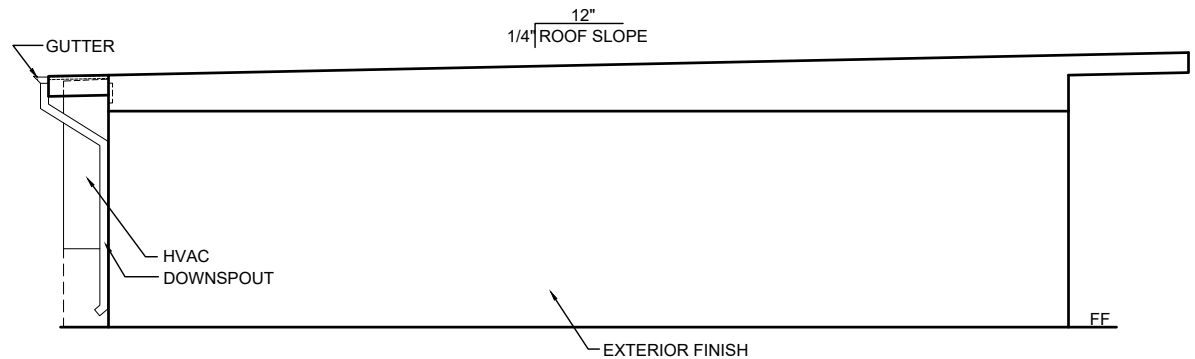
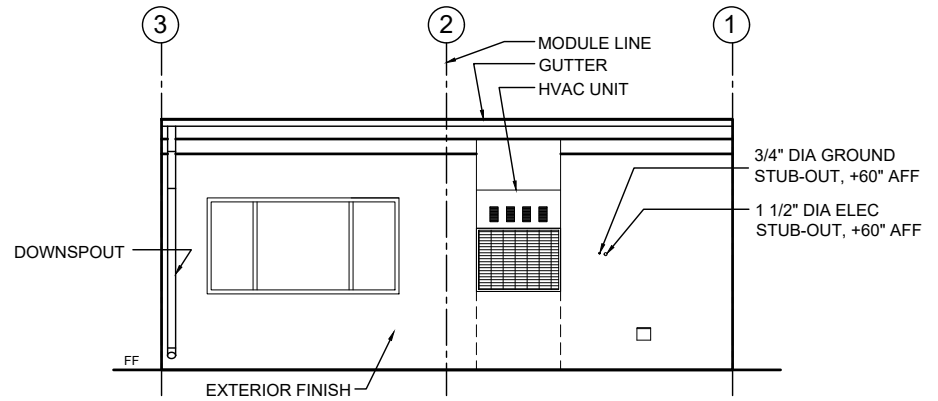
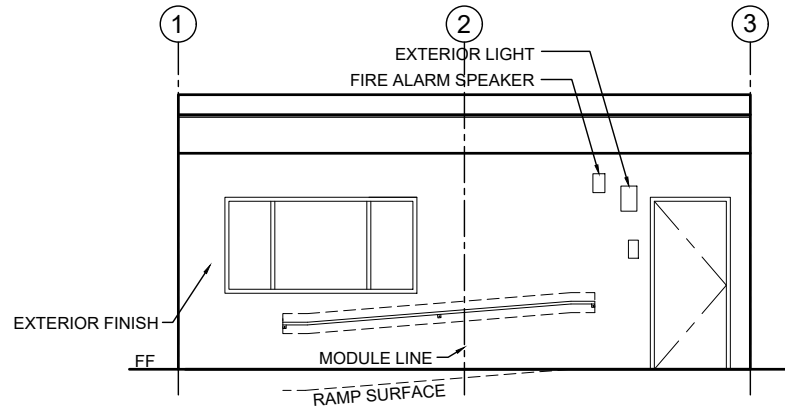
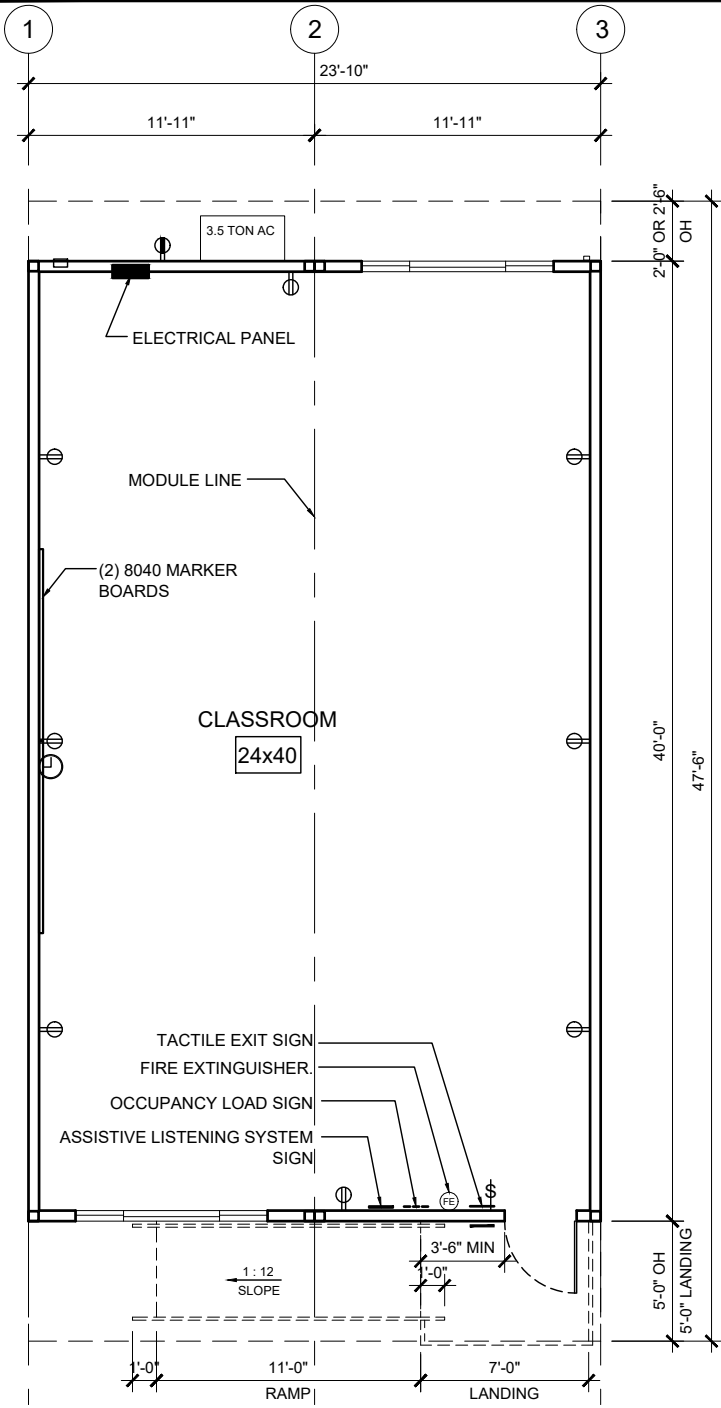

MODEL "M" 24x40 NEW CLASSROOM

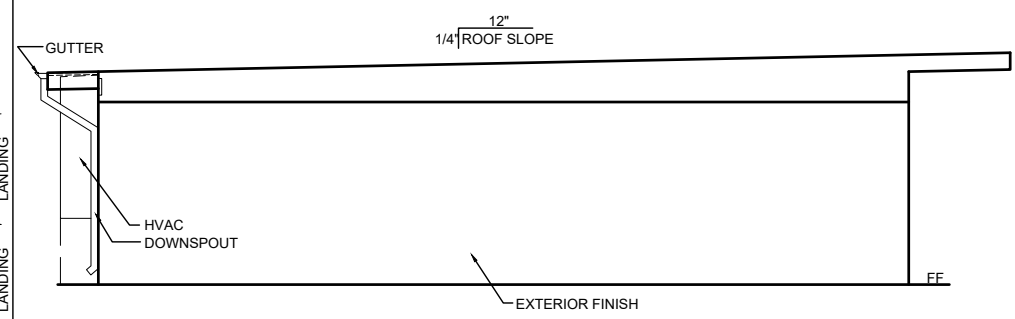
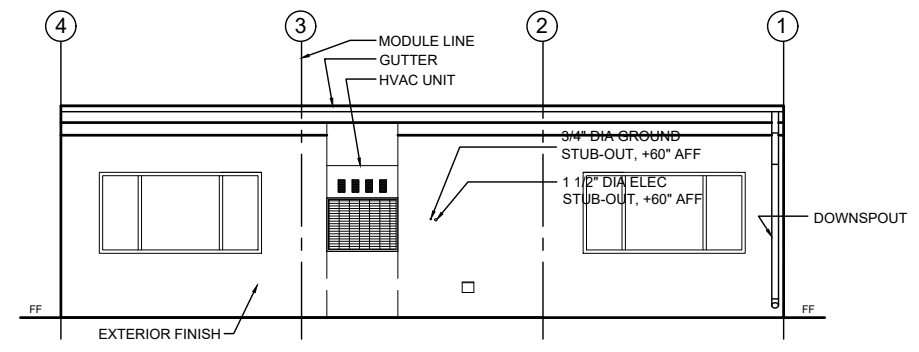
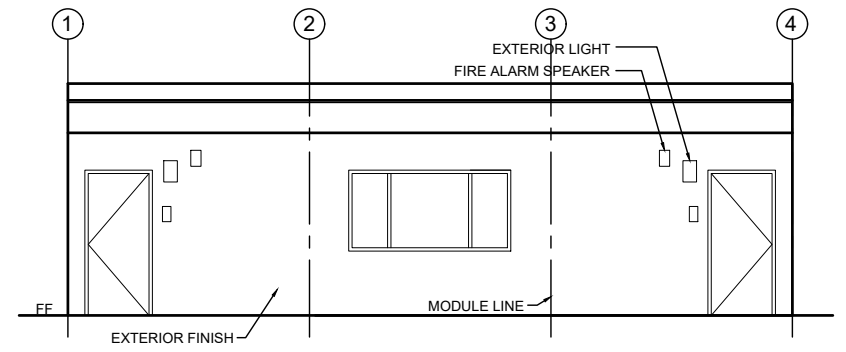
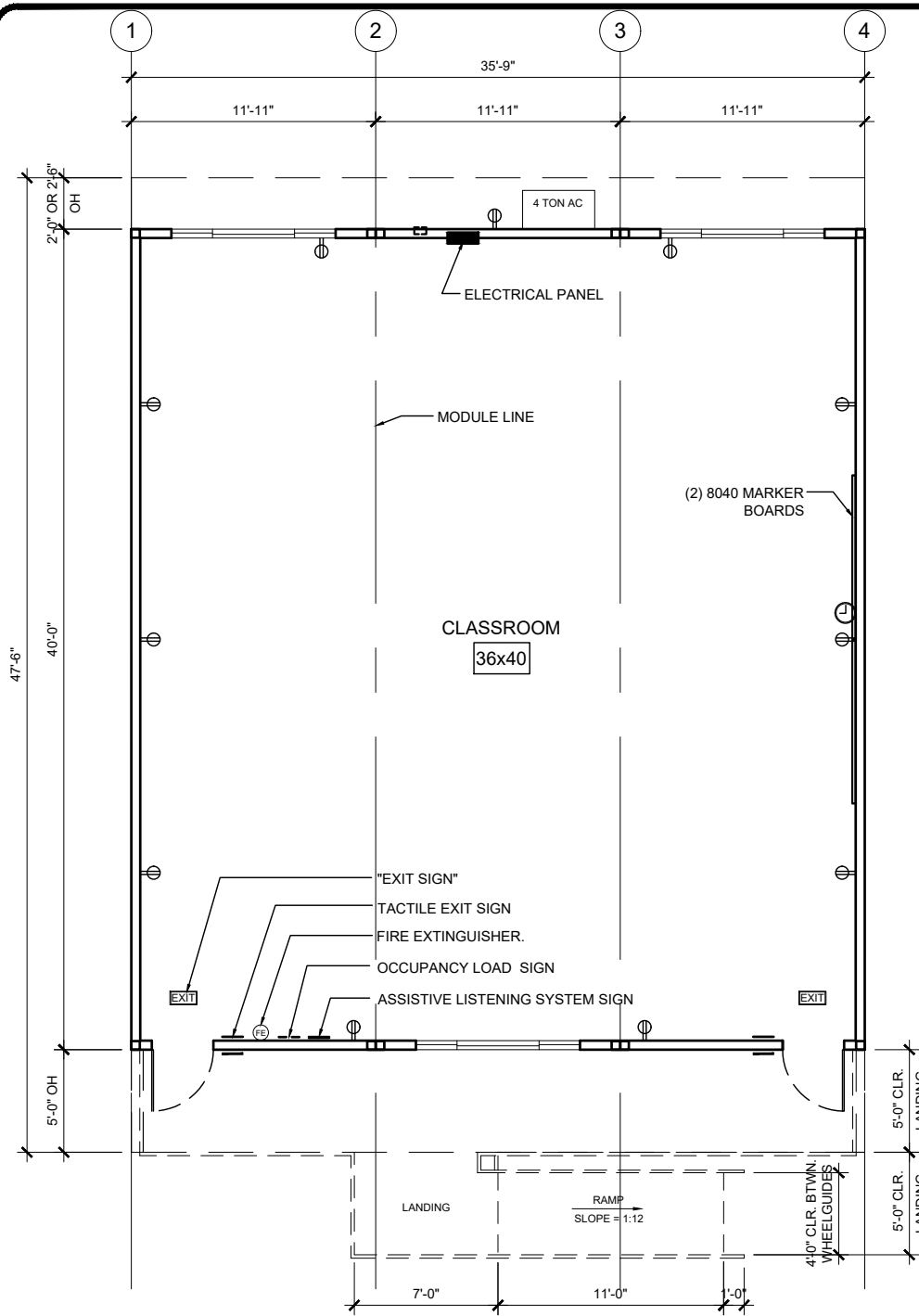

MODEL "N" 36x40 NEW CLASSROOM

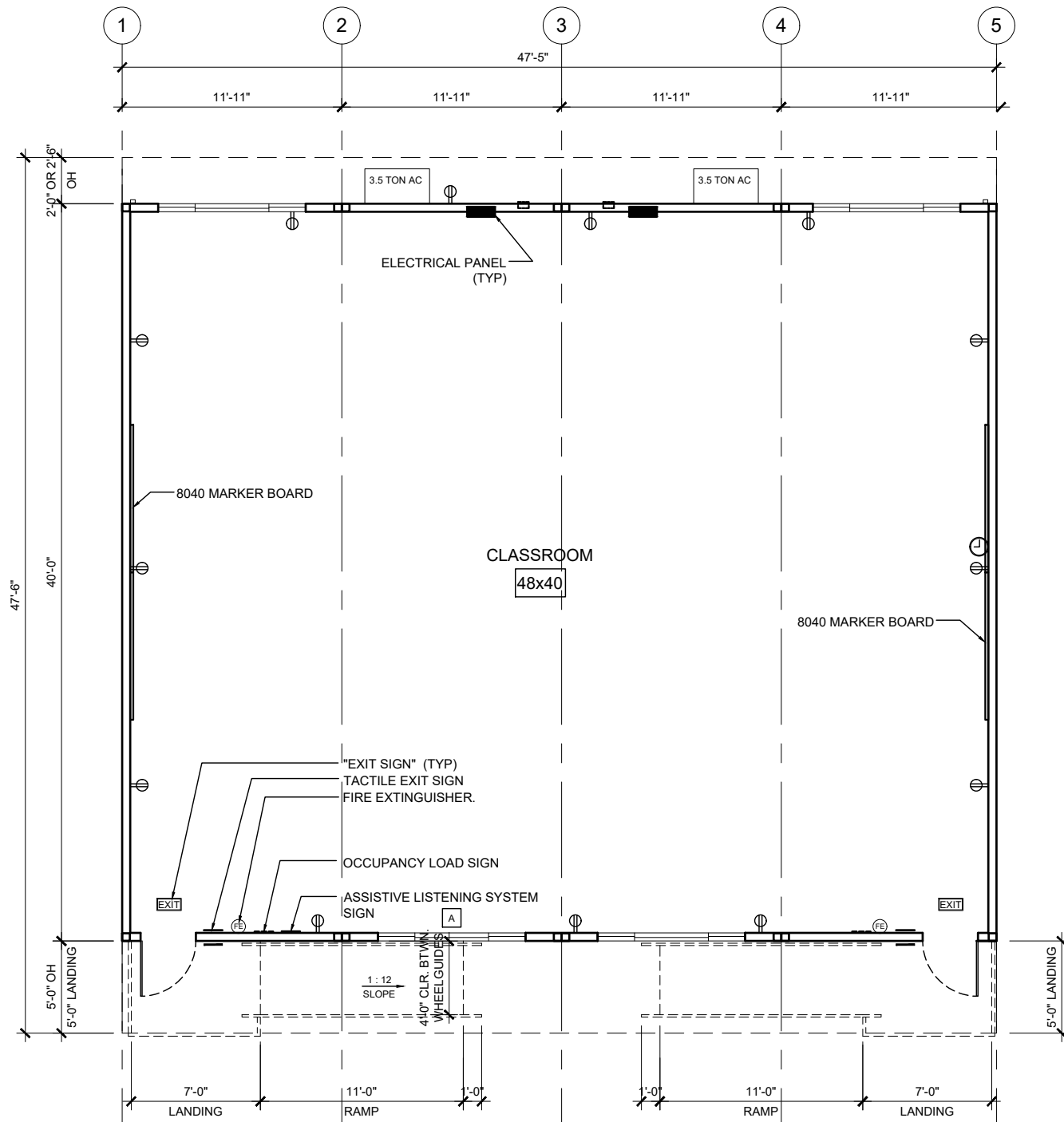

MODEL "O" 48x40 NEW CLASSROOM (FLOOR PLAN)

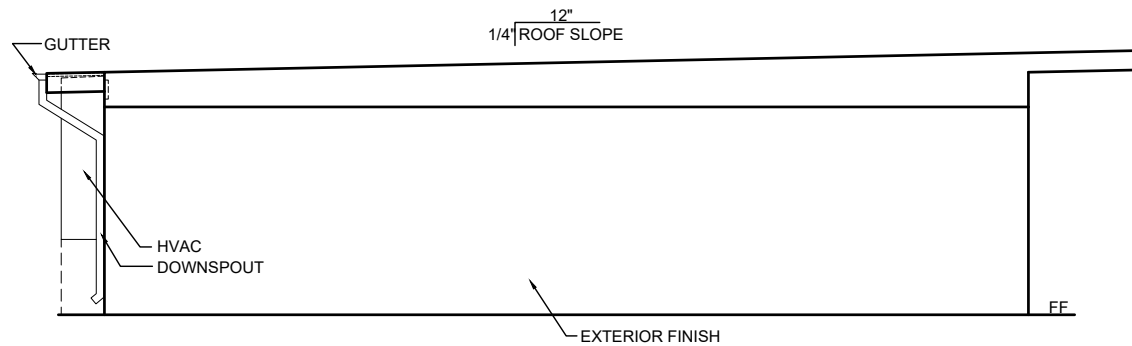
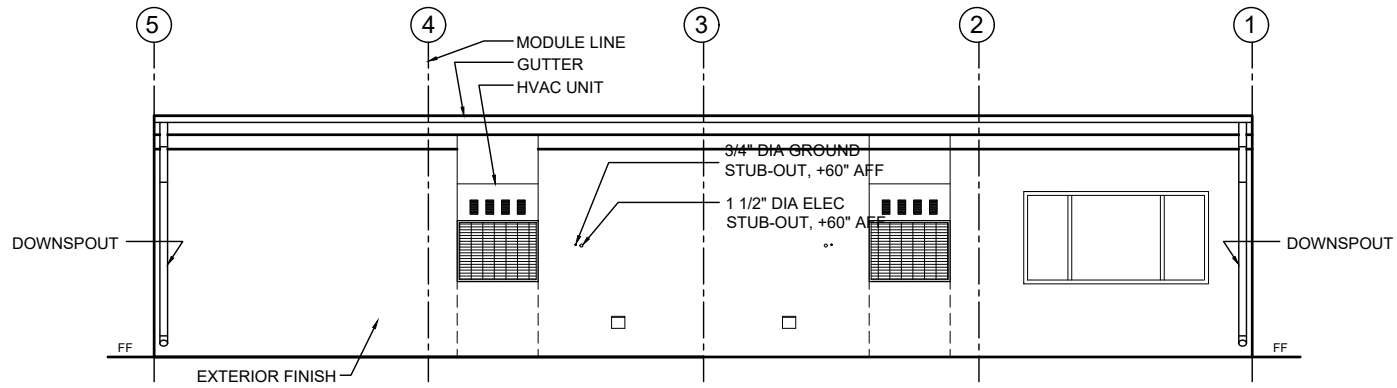
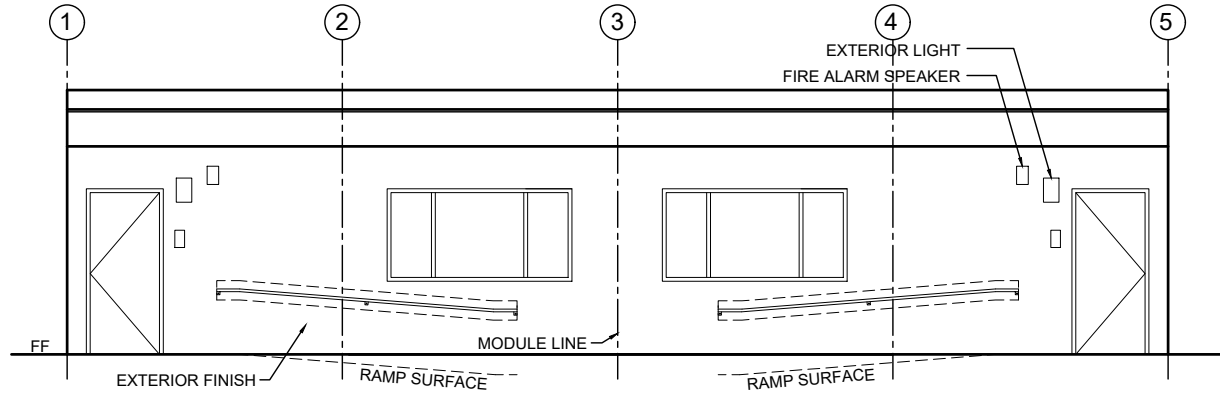

MODEL "O" 48x40 NEW CLASSROOM (EXT.ELEV.)

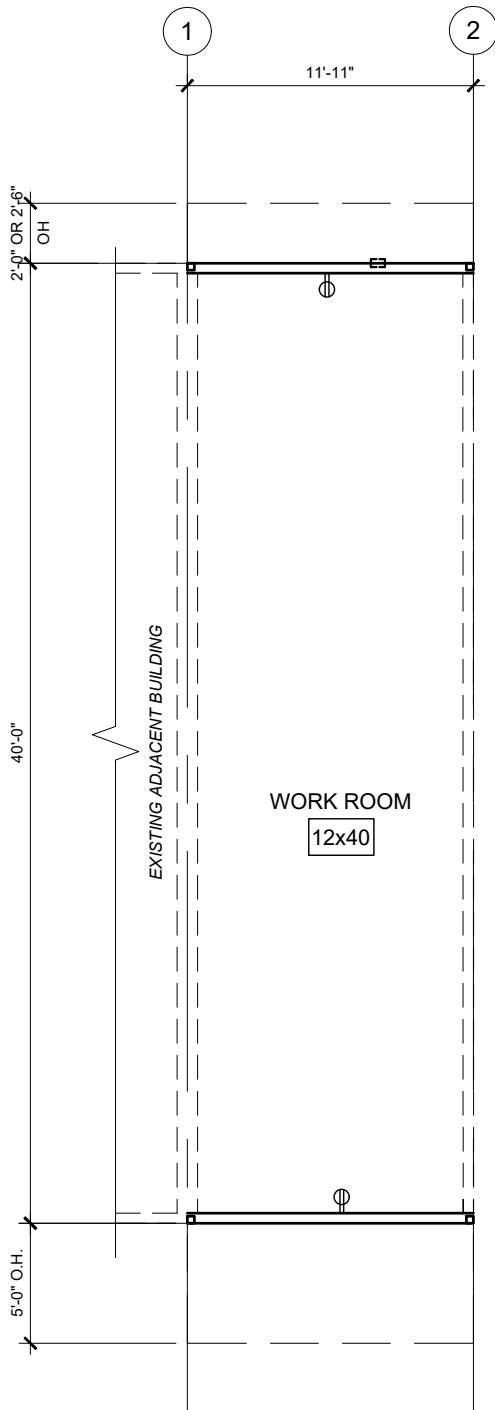

NOTE:
 MODULE MAY BE
 INSTALLED BETWEEN
 EXISTING MODULES OR
 AT THE END FOR
 BUILDING EXPANSION

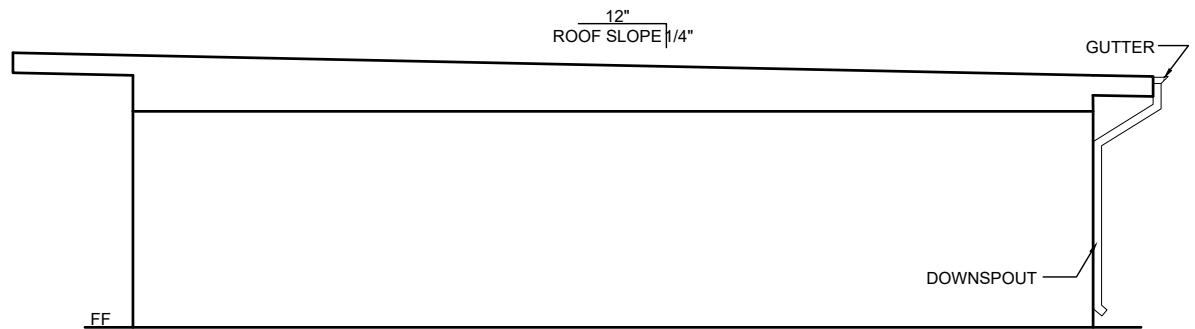
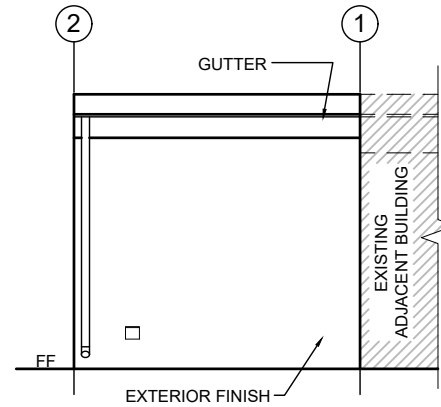
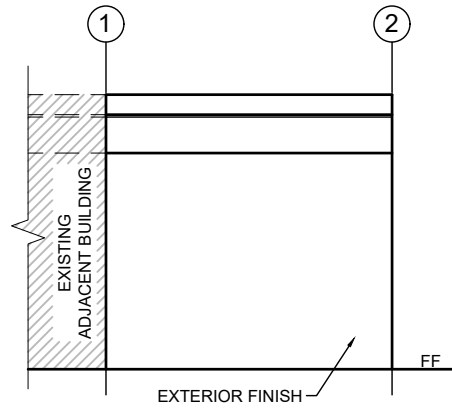

MODEL "P" 12x40 NEW ADD-ON MODULE

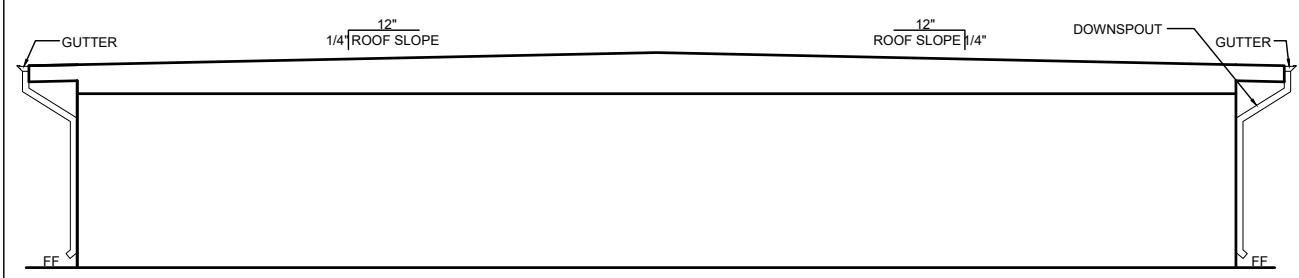
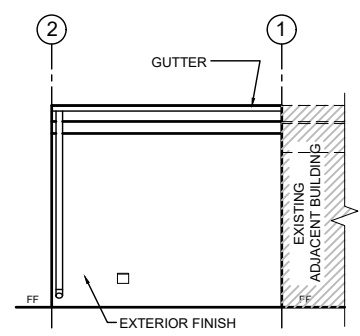
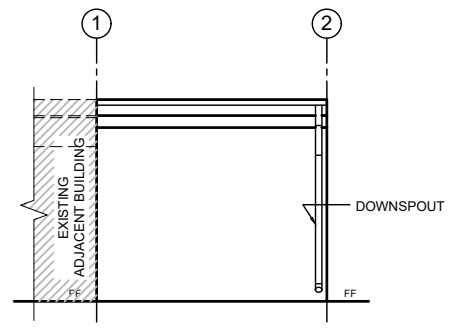
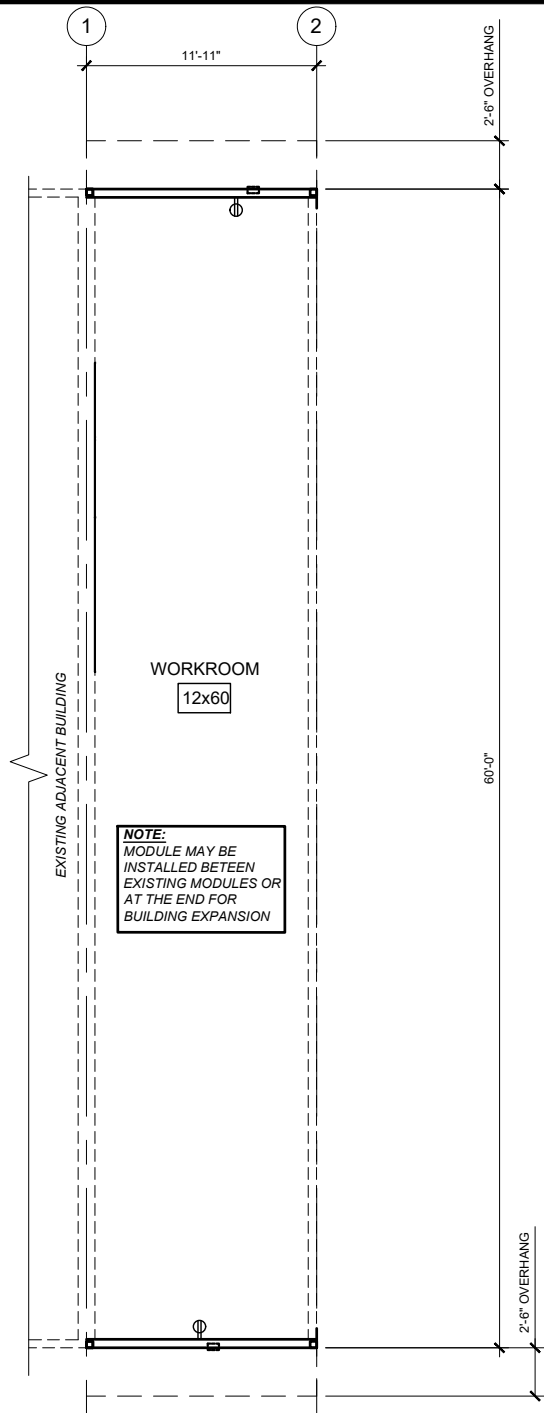

MODEL "R" 12x60 NEW ADD-ON MODULE

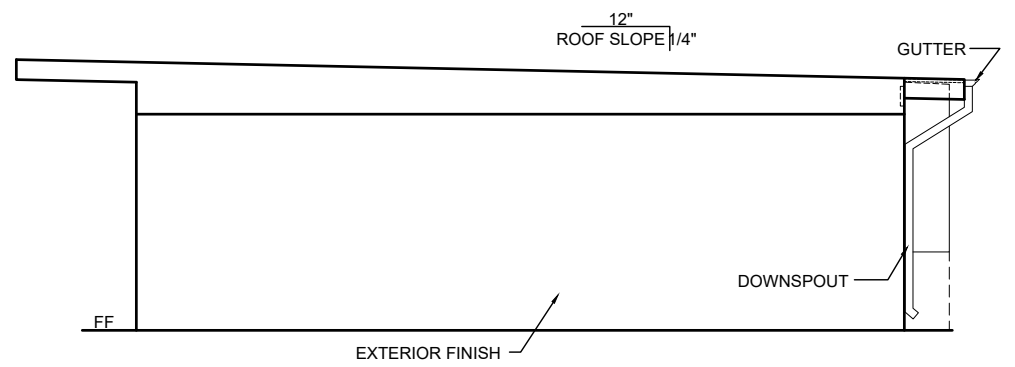
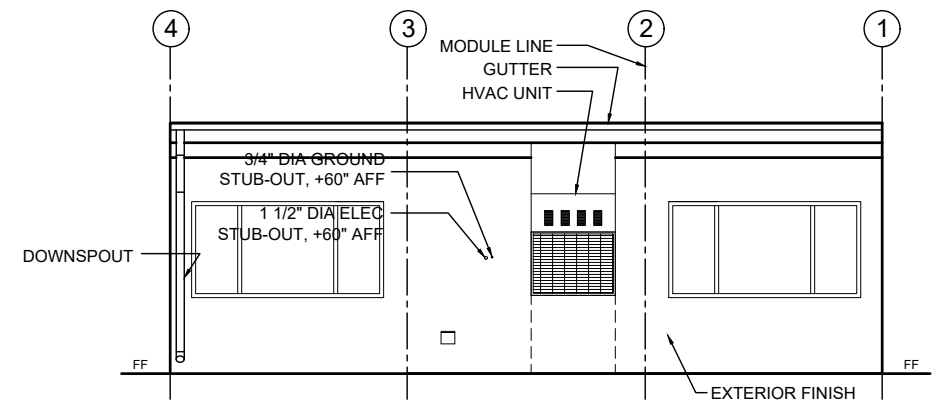
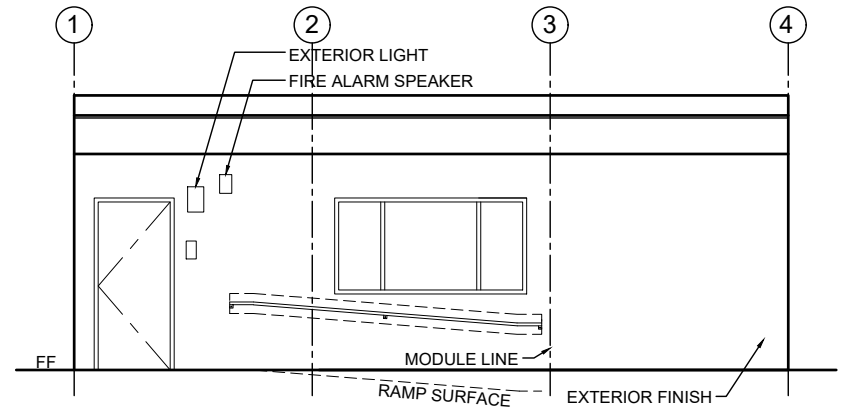
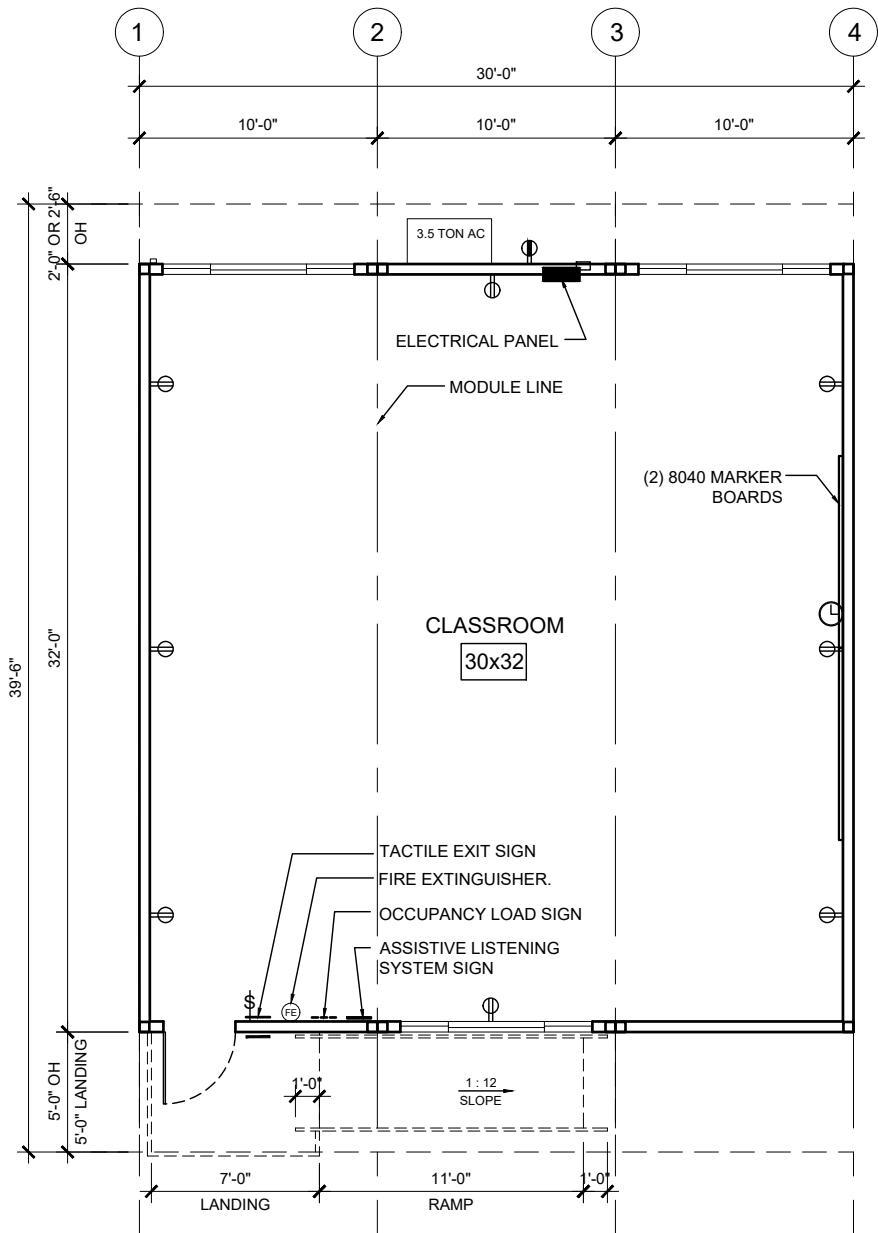

MODEL "S" 30x32 NEW CLASSROOM

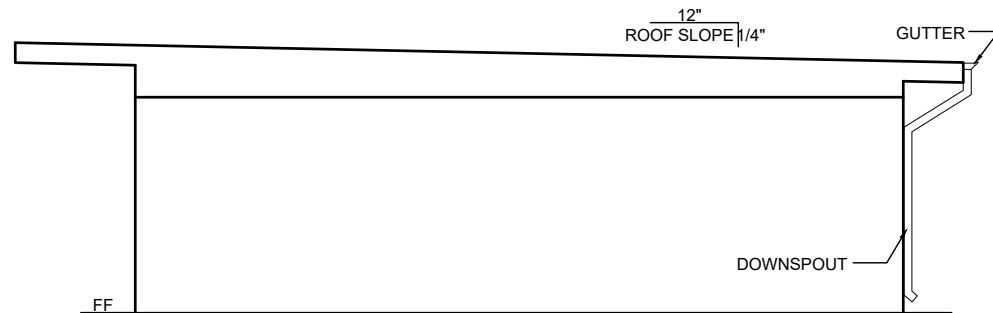
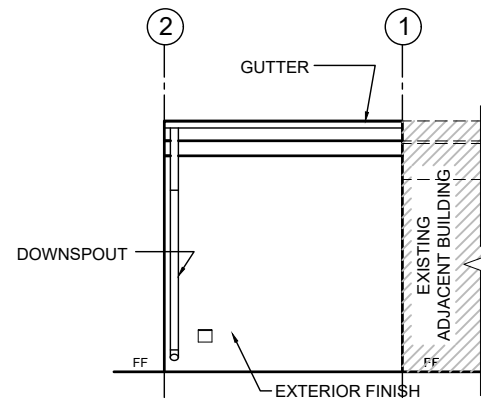
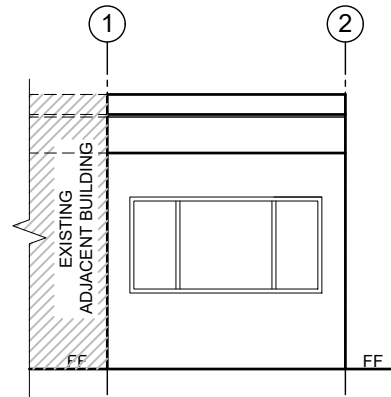
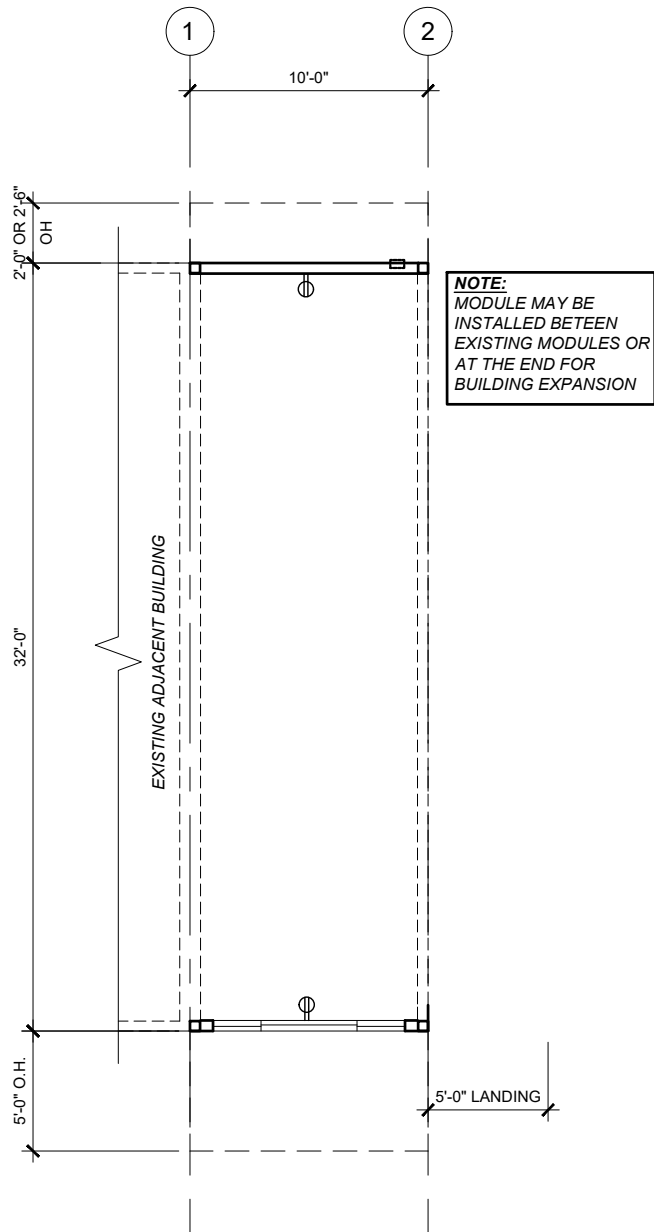

MODEL "T" 10x32 NEW ADD-ON MODULE

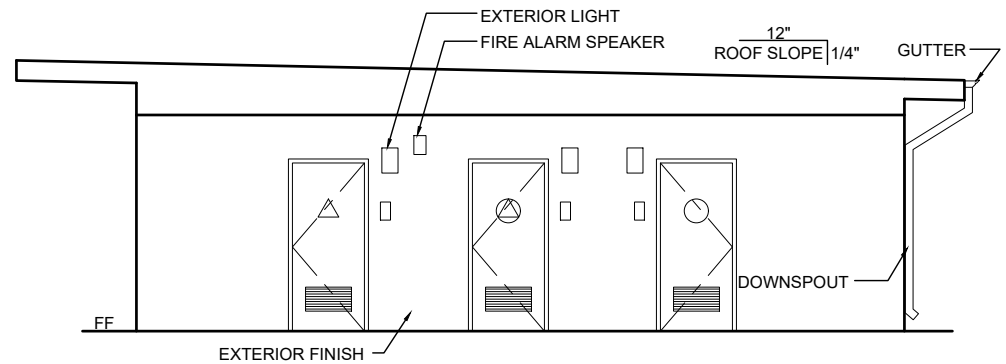
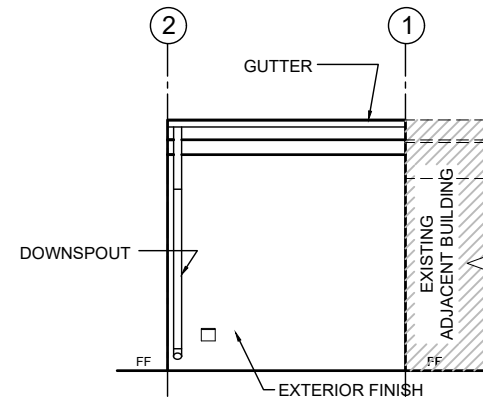
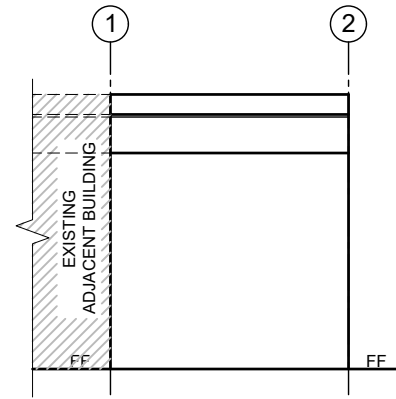
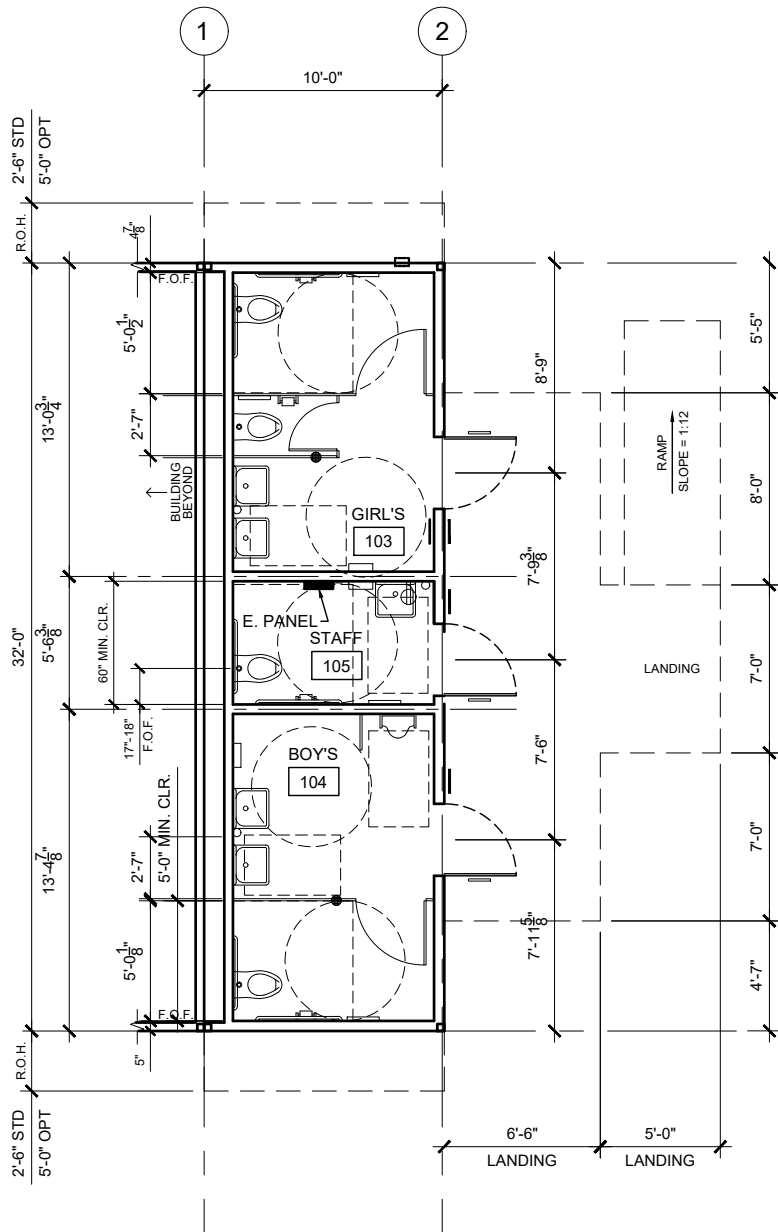

MODEL "U" 10x32 NEW RESTROOM MODULE

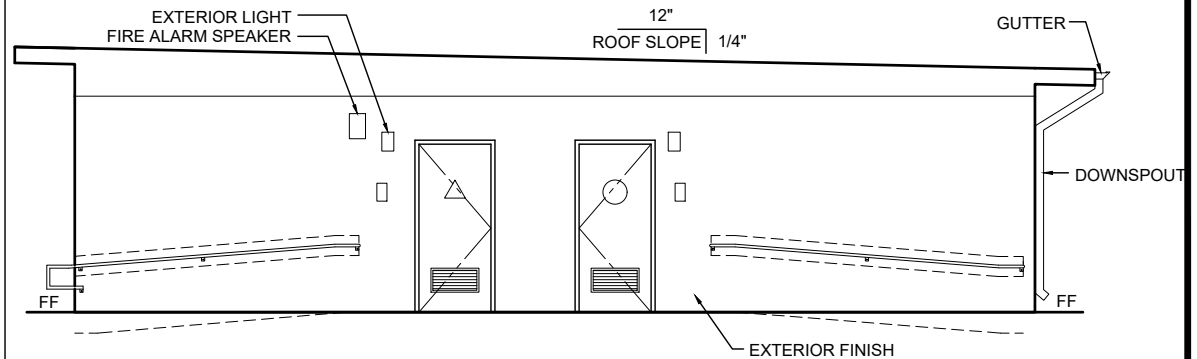
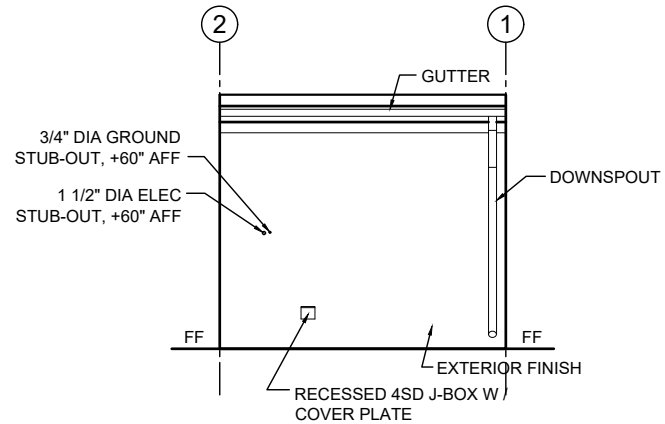
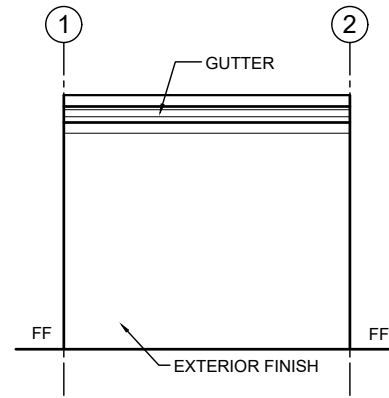
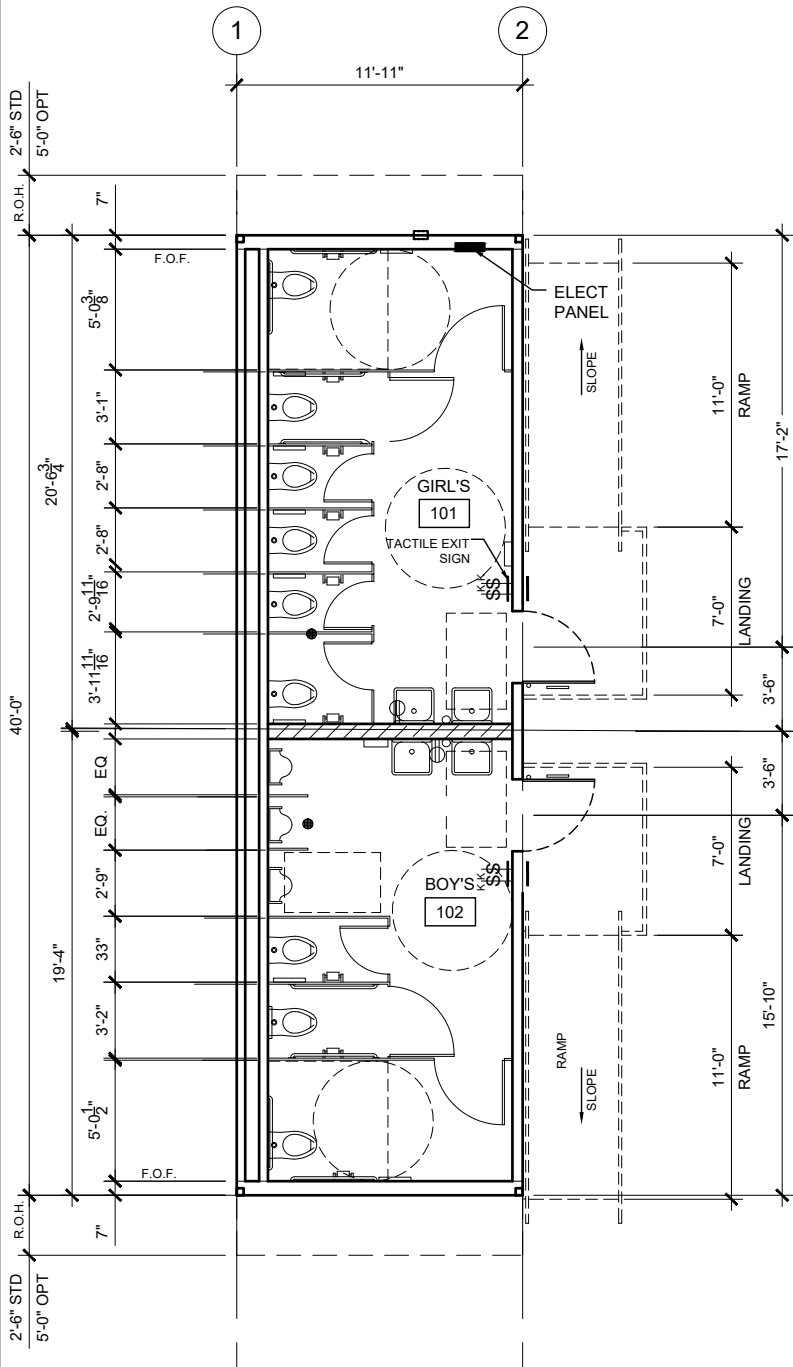

MODEL "V" 12x40 NEW RESTROOM B/G

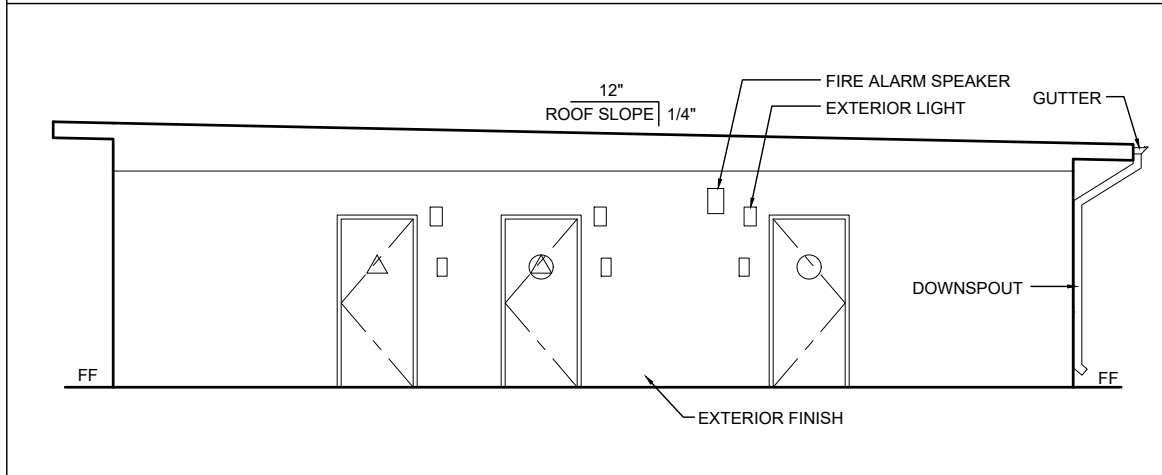
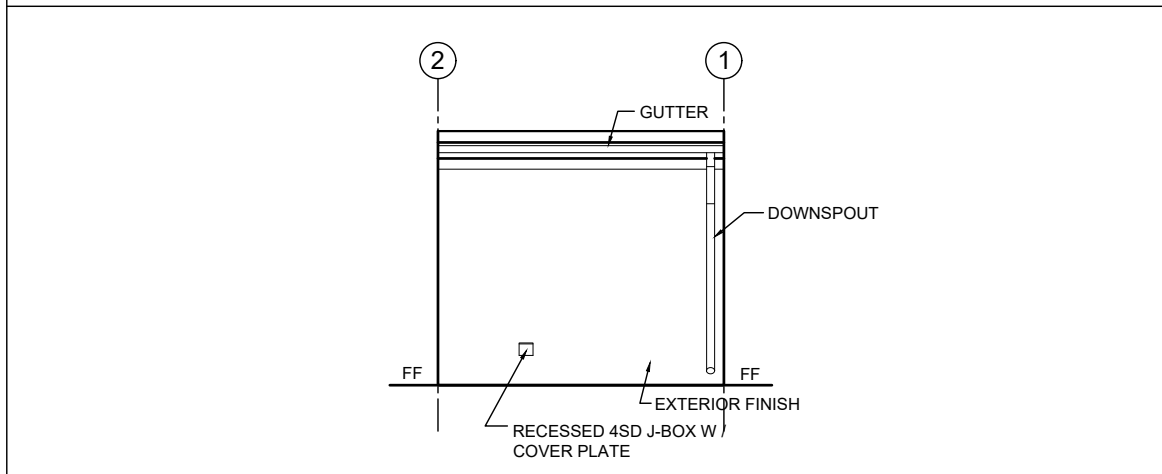
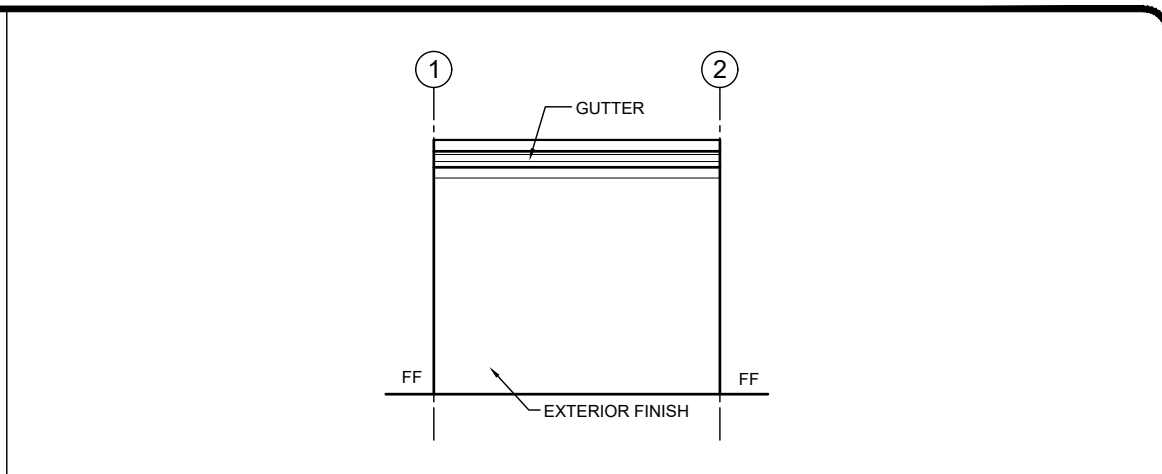
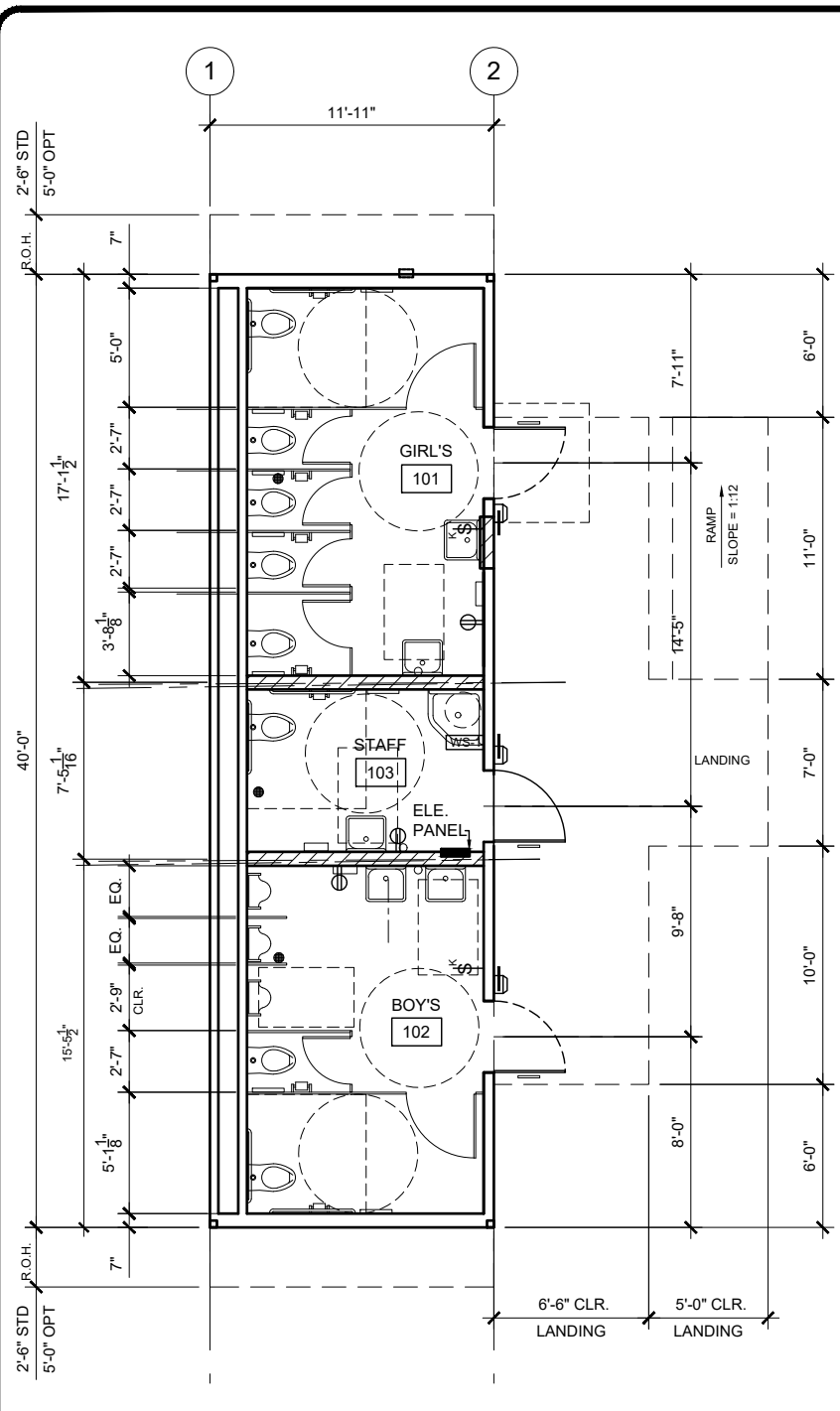

MODEL "W" 12x40 NEW RESTROOM B/S/G

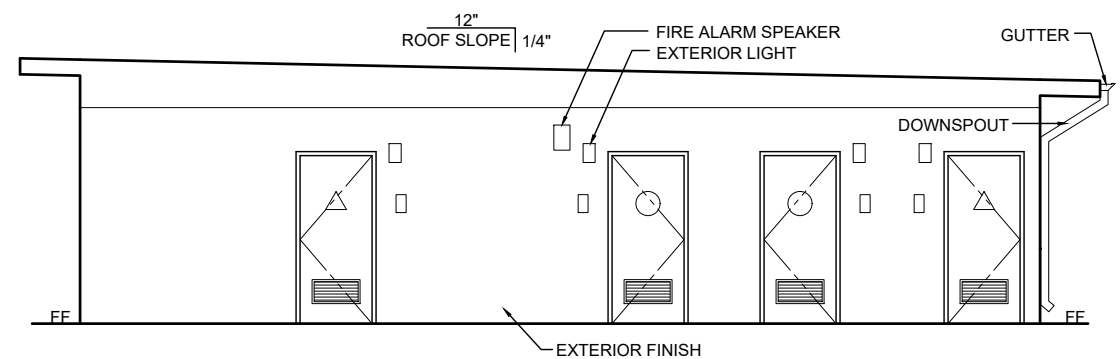
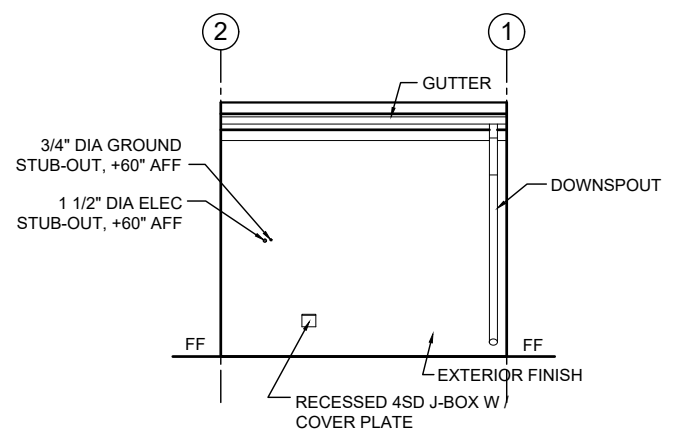
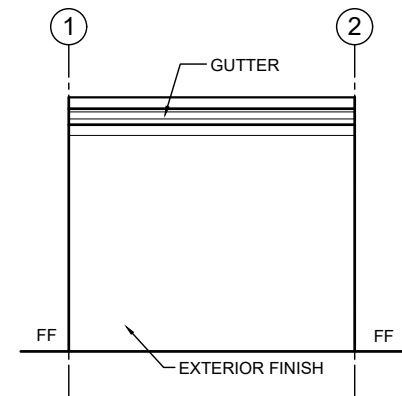
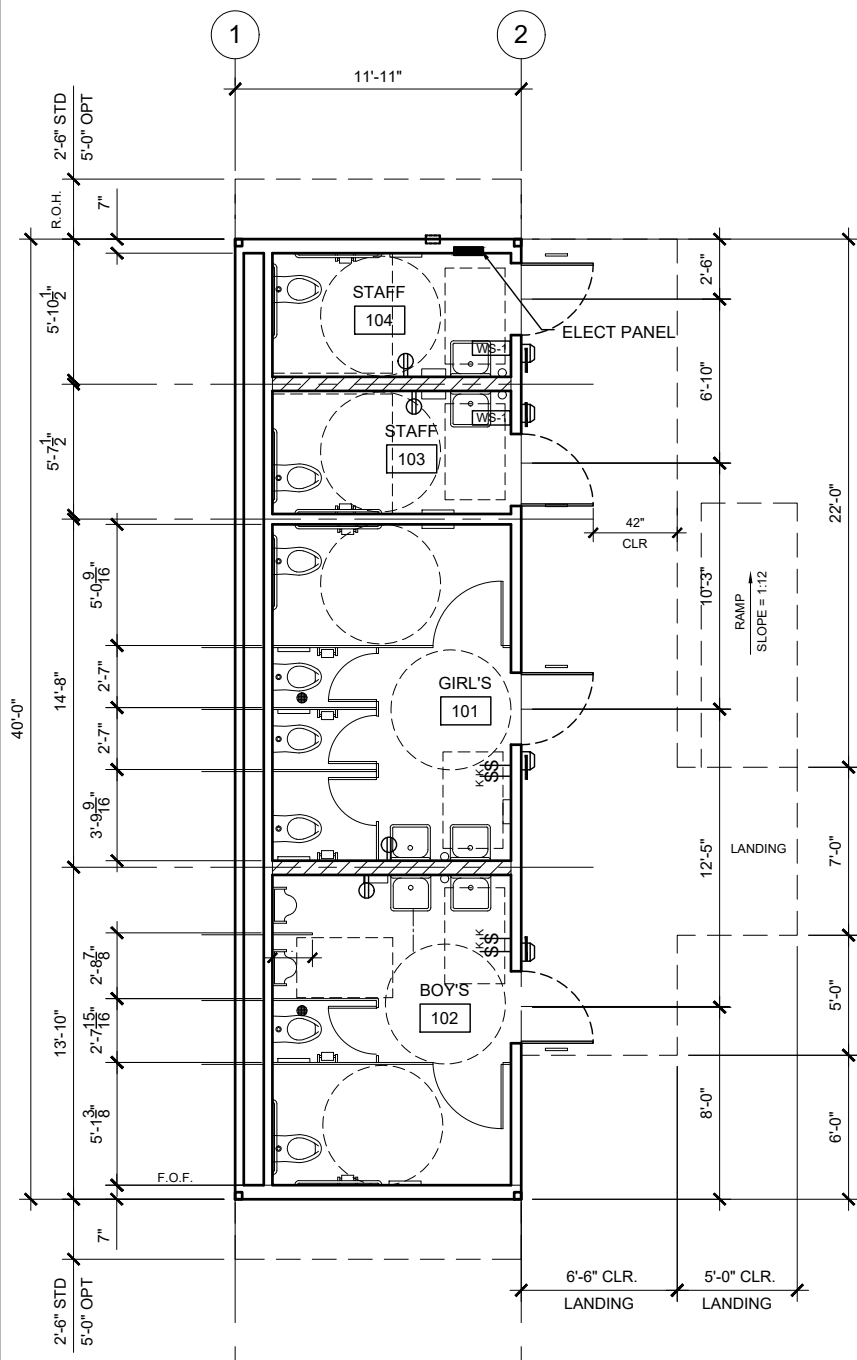

MODEL "X" 12x40 NEW RESTROOM B/G/S/S

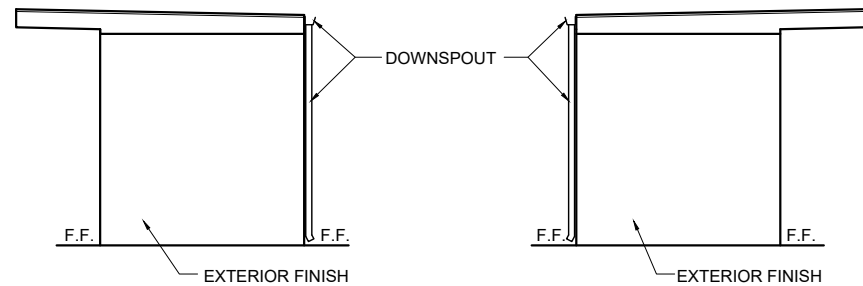
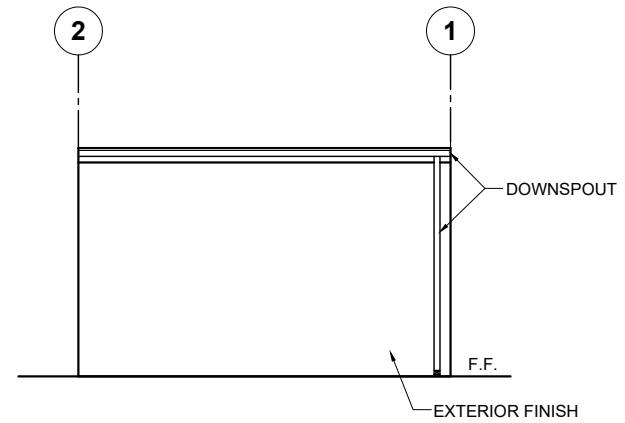
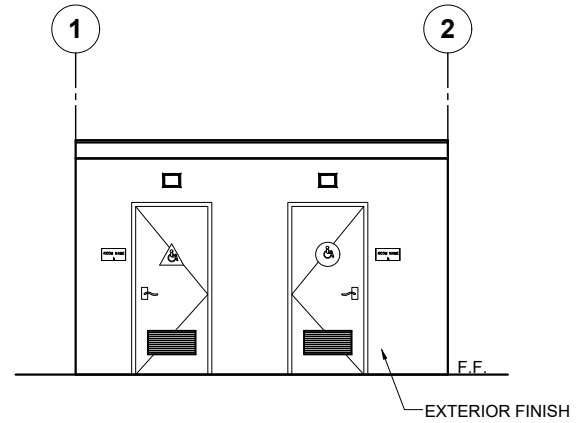
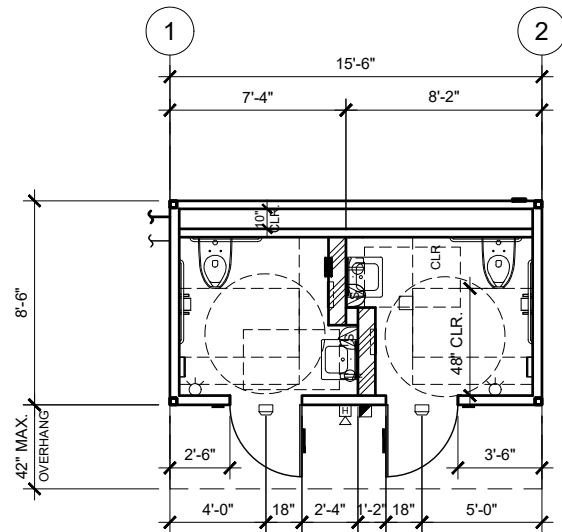

MODEL "Y" 8'-6"x15'-6" NEW RESTROOM B/G

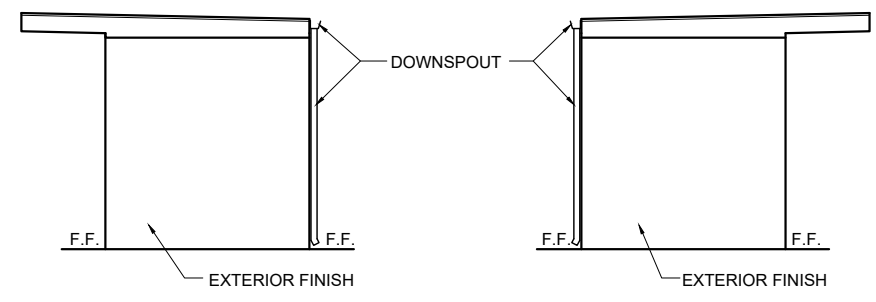
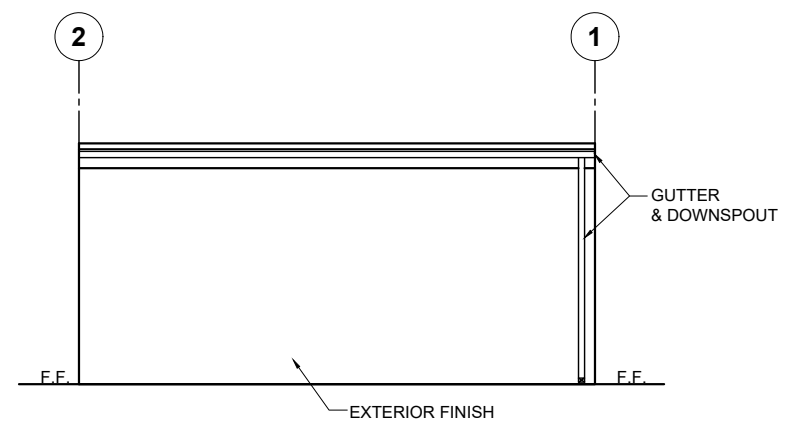
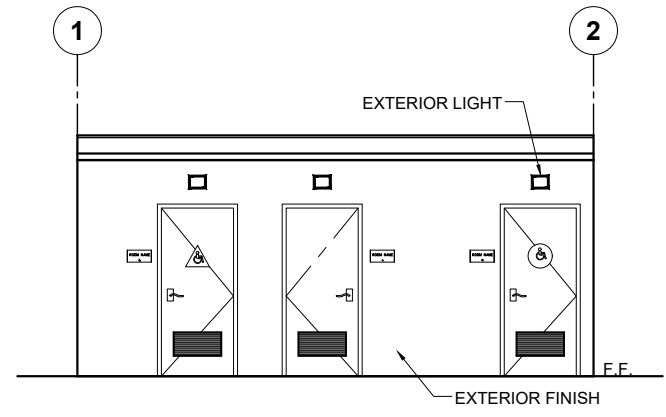
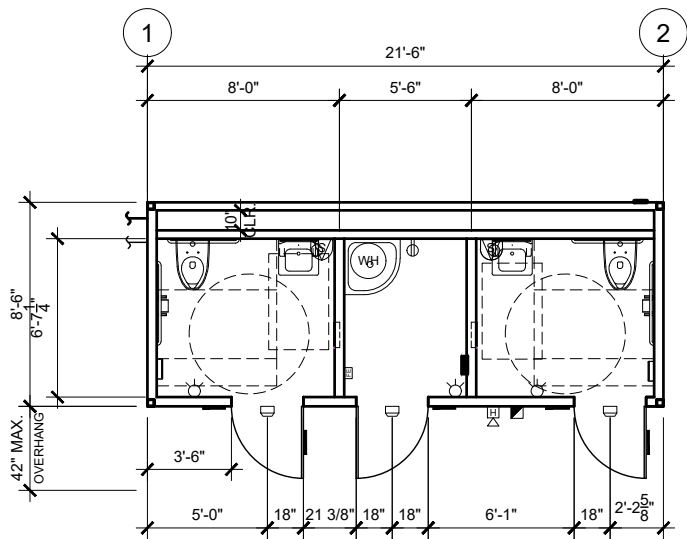

MODEL "Z" 8'-6"x21'-6" NEW RESTROOM B/S/G

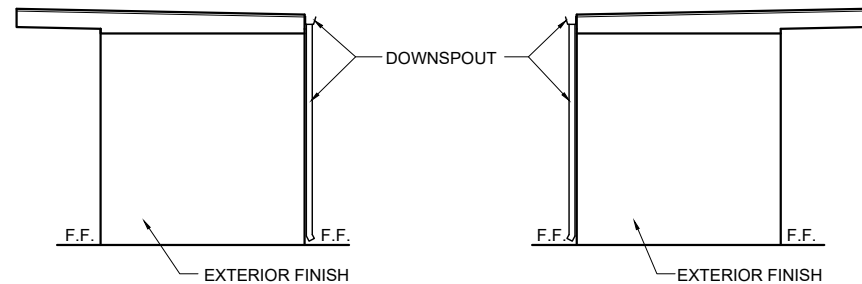
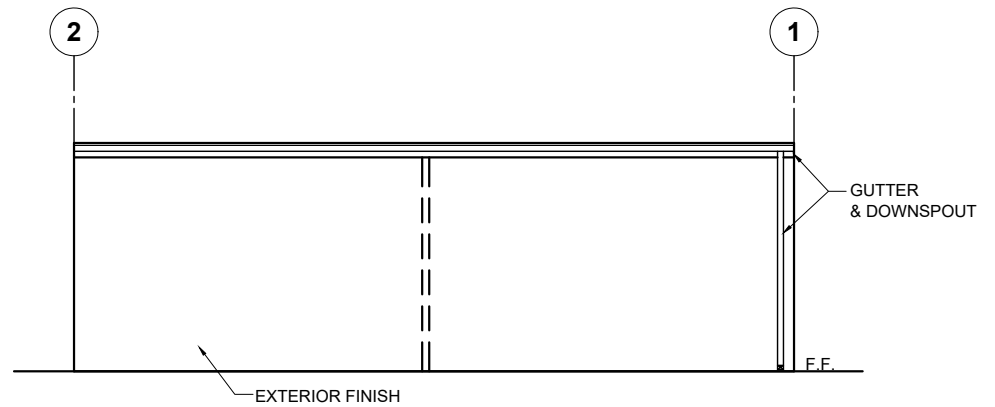
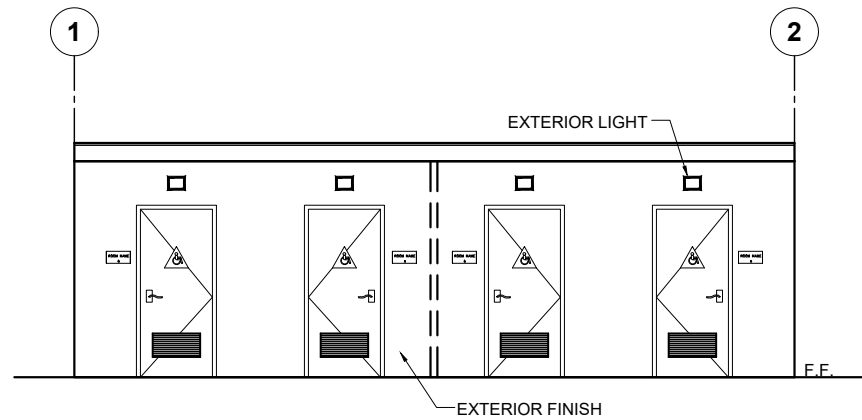
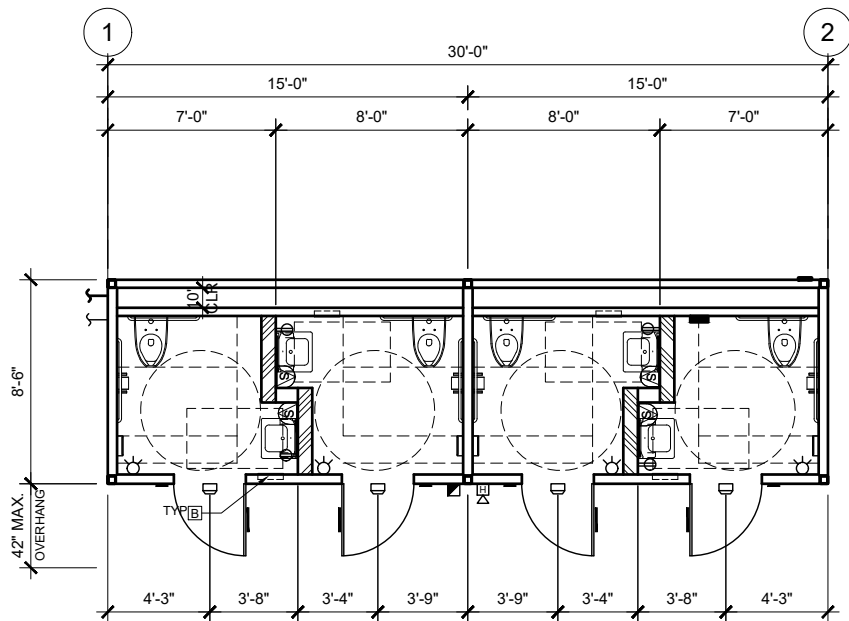

MODEL "AA" 8'-6"x30'-0" NEW RESTROOM B/G/S/S

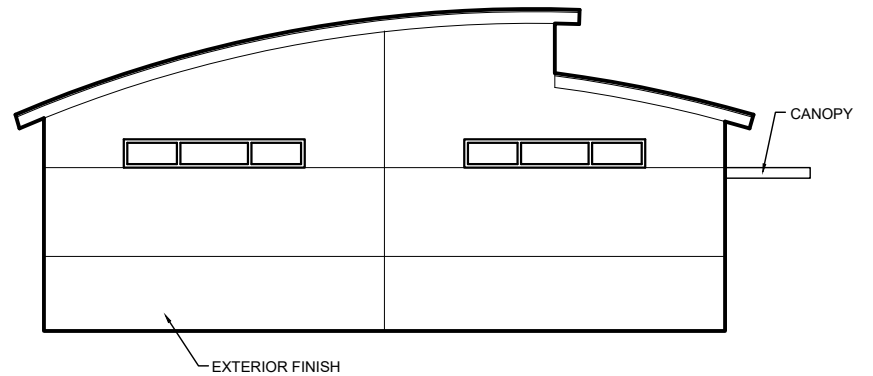
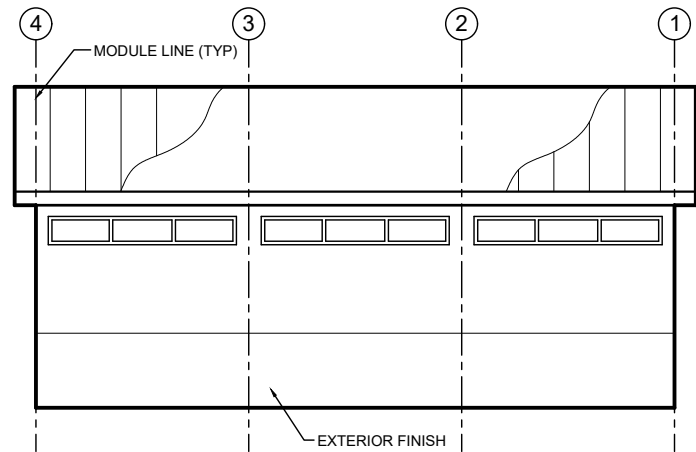
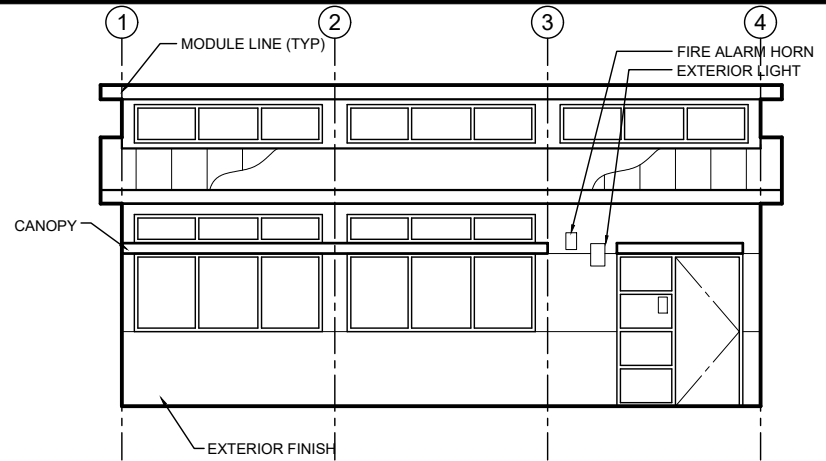
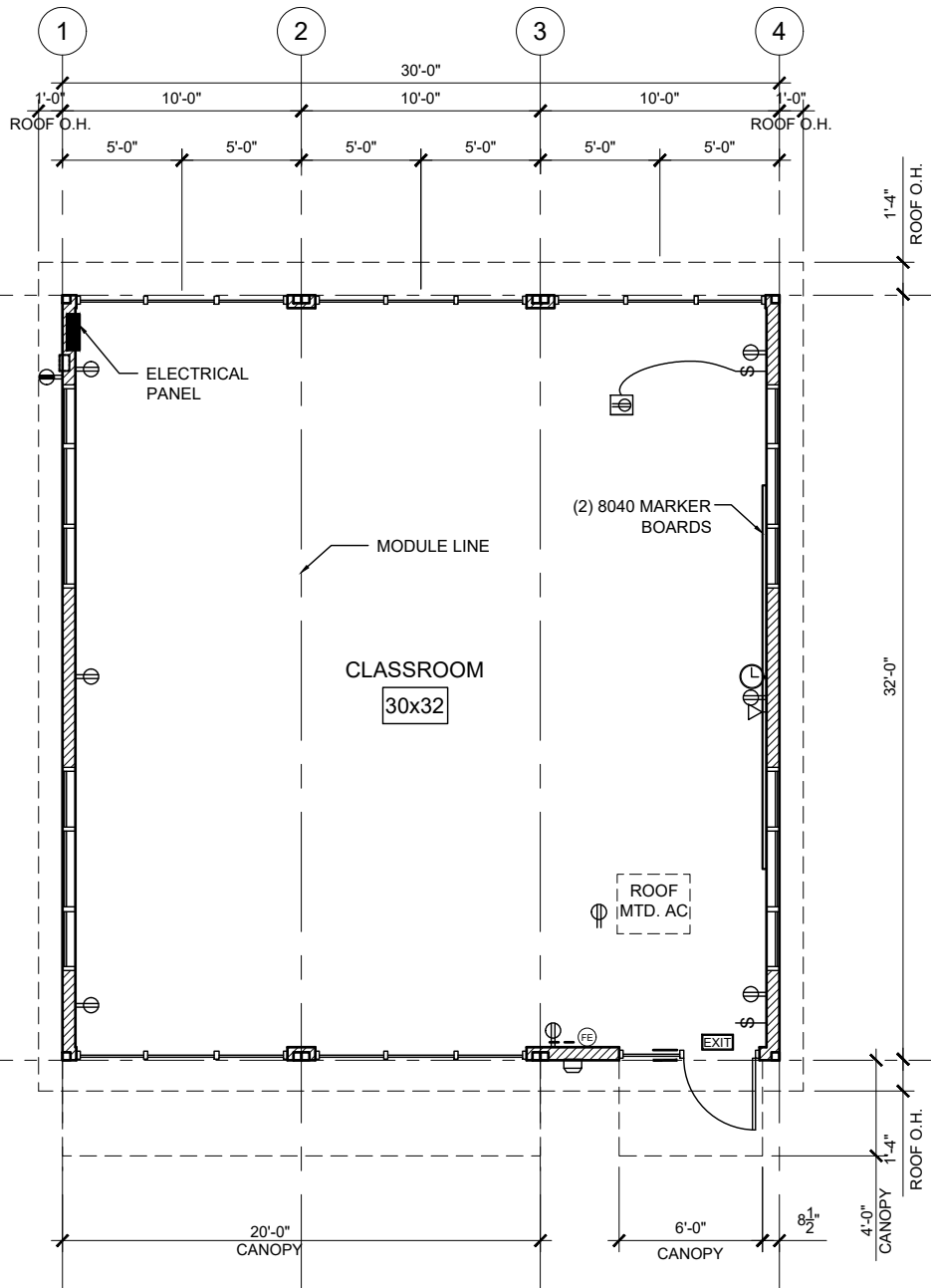

MODEL "AB" 30x32 NEW HIGH PERFORMANCE CLASSROOM

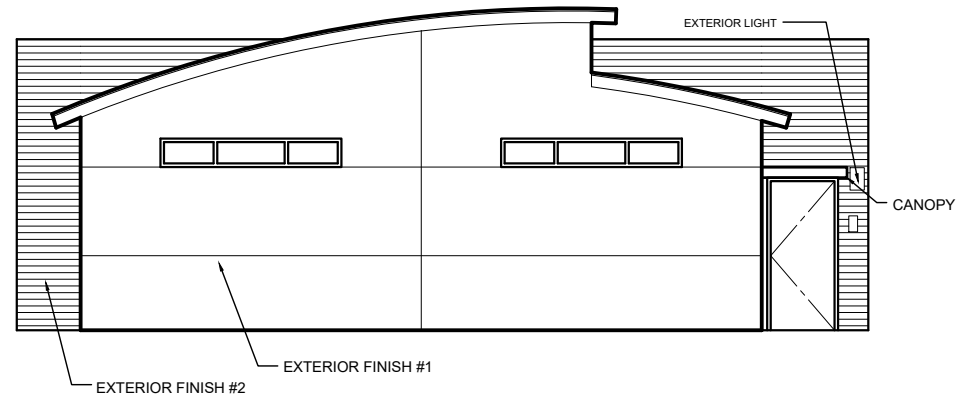
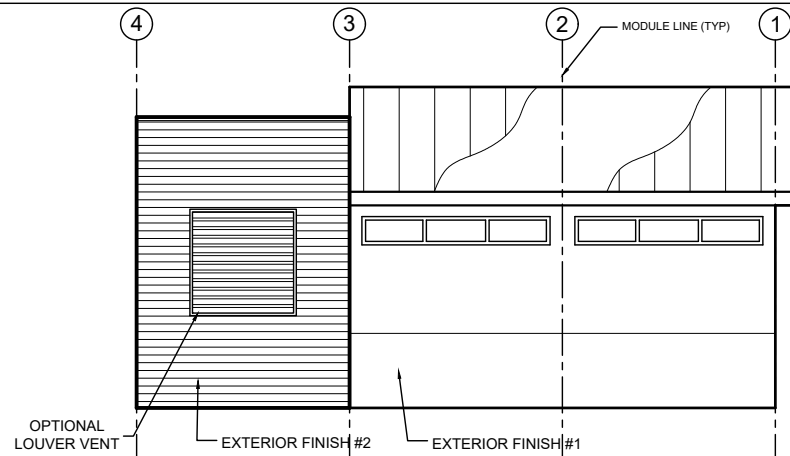
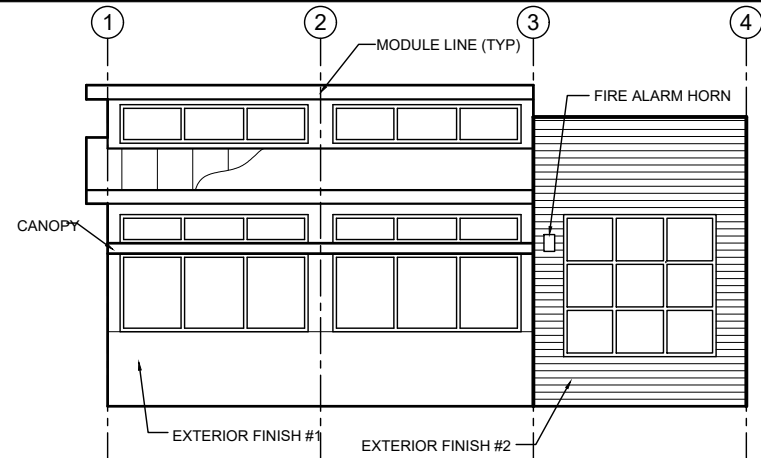
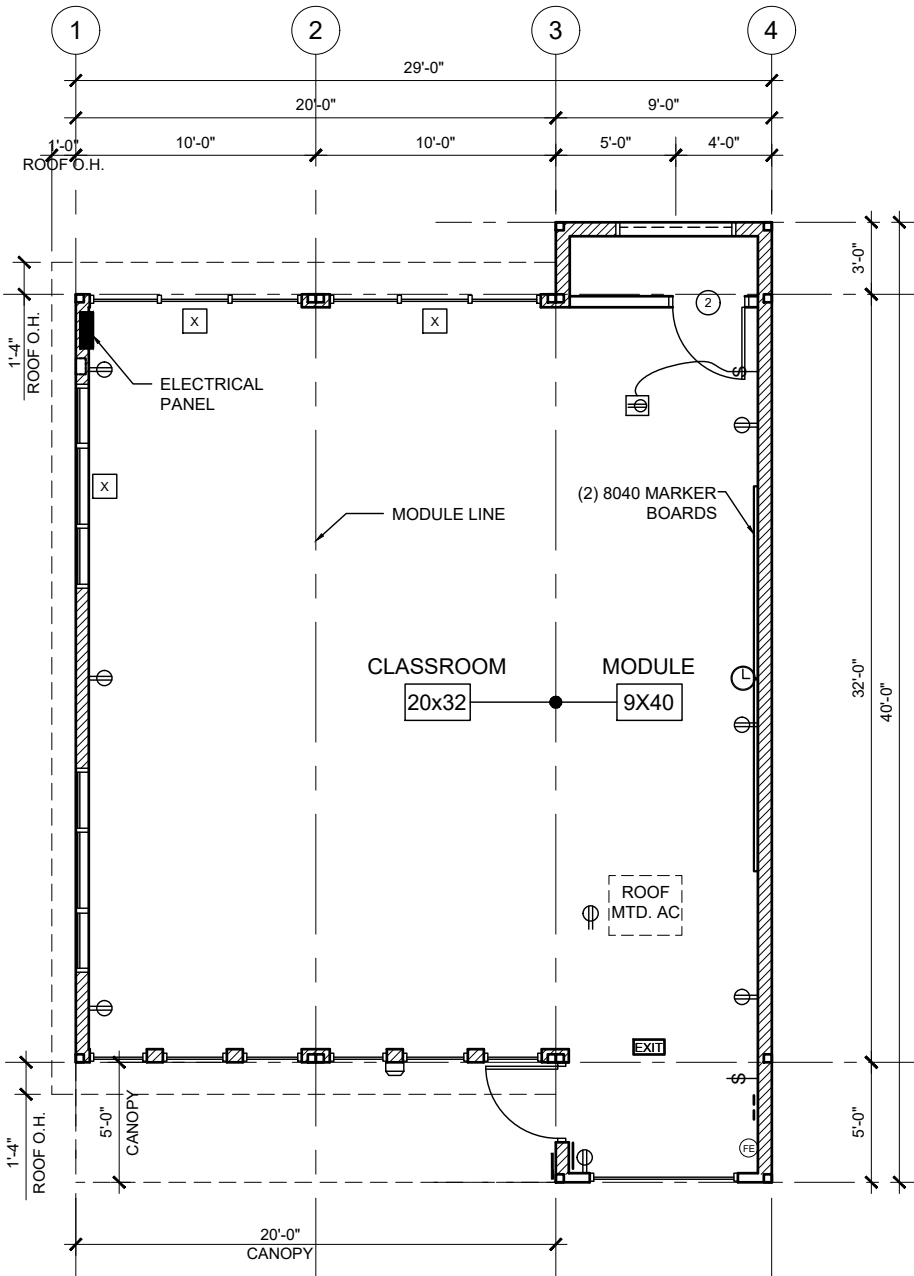

MODEL "AC" 20x32 & 9x40 NEW HIGH PERFORMANCE CLASSROOM

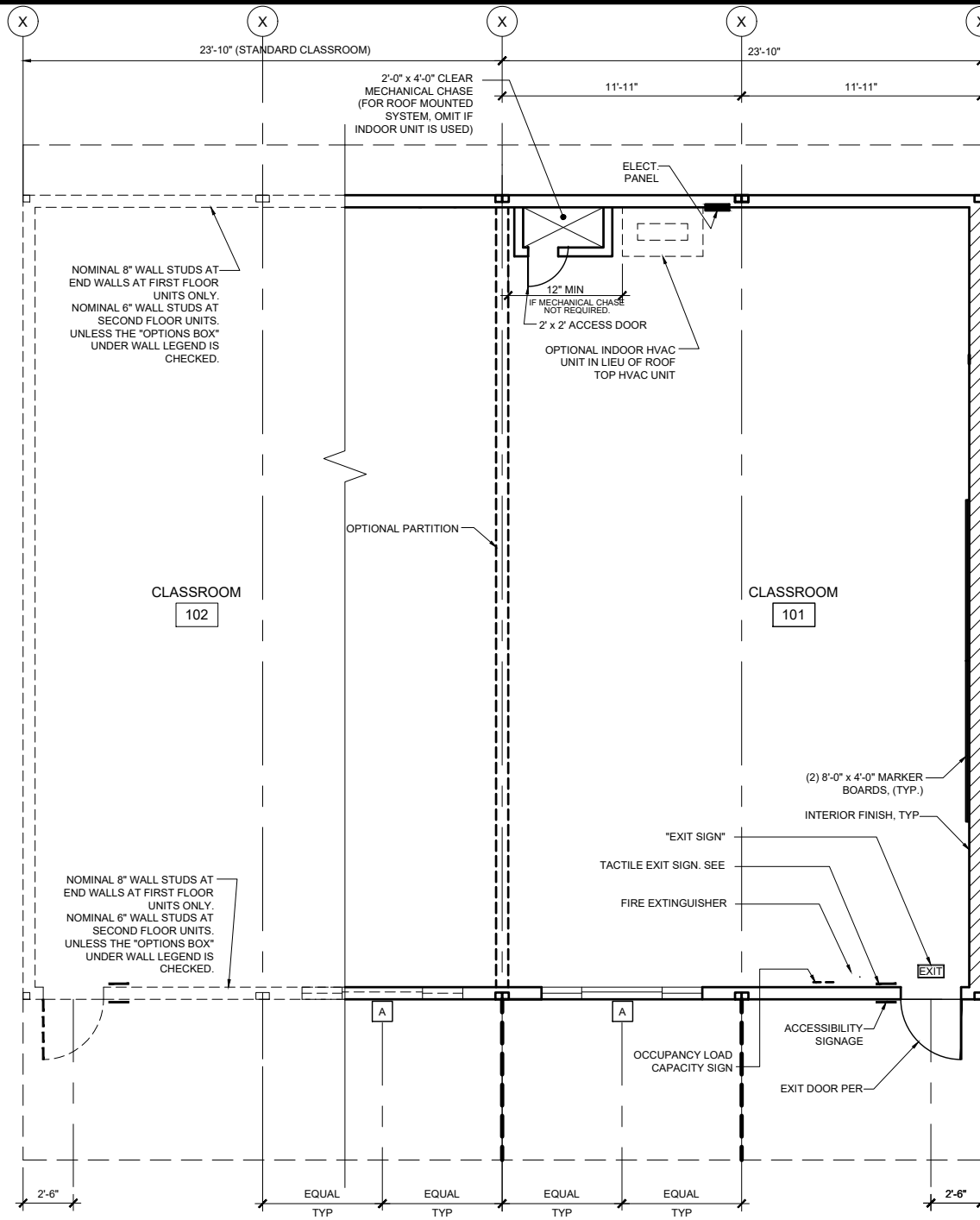

NOTE:
FLOOR PLAN LAYOUT
SHOWN IS TYPICAL FOR
1st AND 2nd FLOOR

MODEL "AD" 48x40 TWO STORY NEW CLASSROOM (FLOOR PLAN)

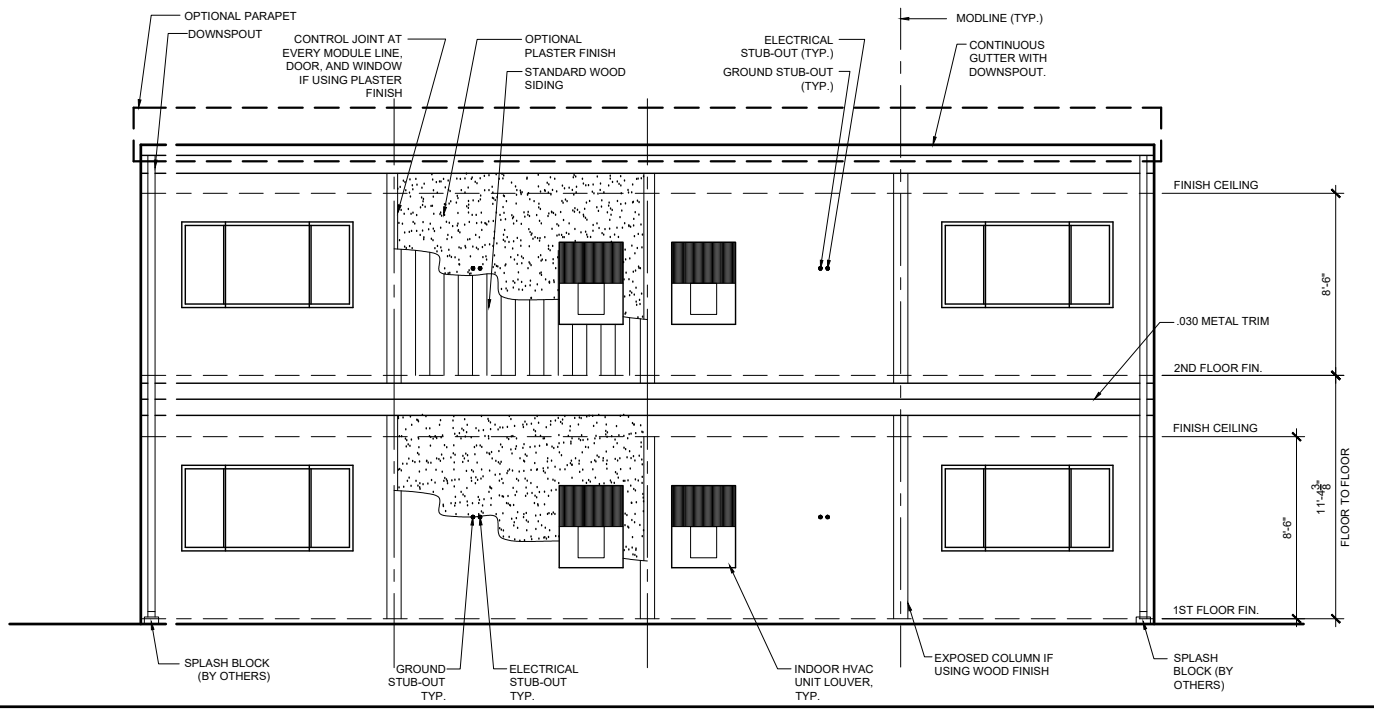
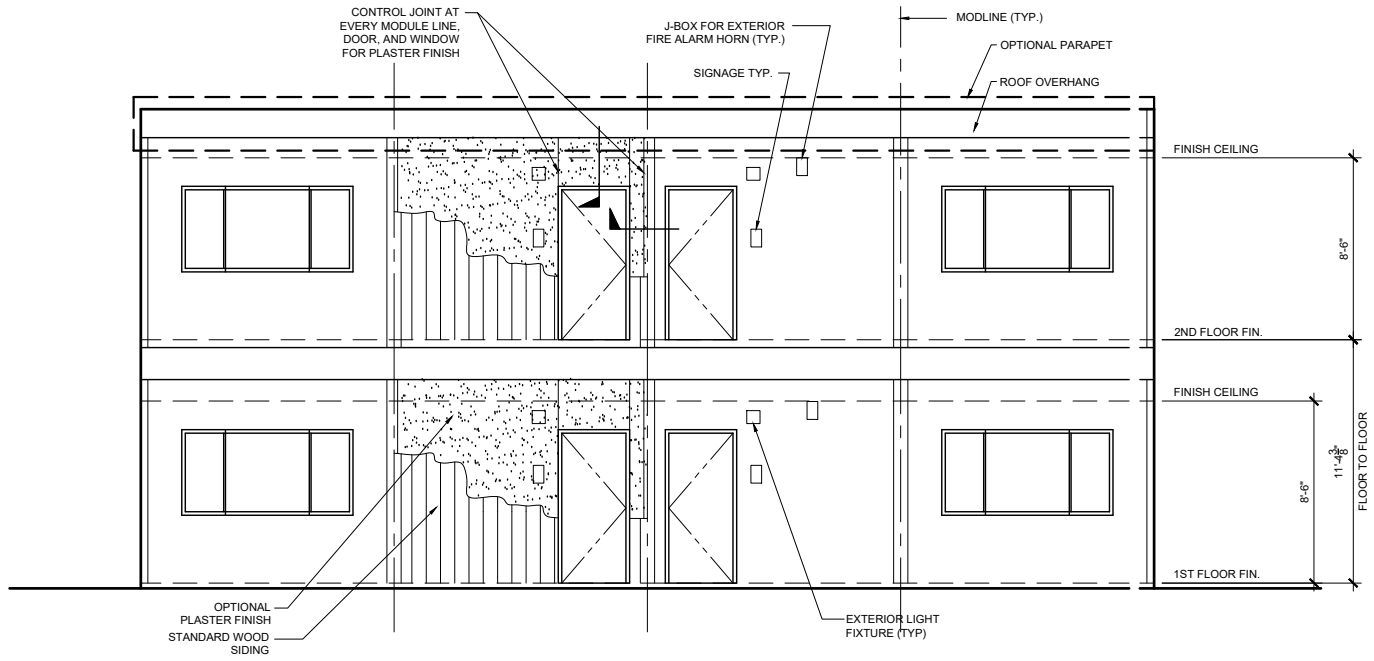

MODEL "AD" 48x40 NEW -STORY CLASSROOM (EXT.ELEV.)

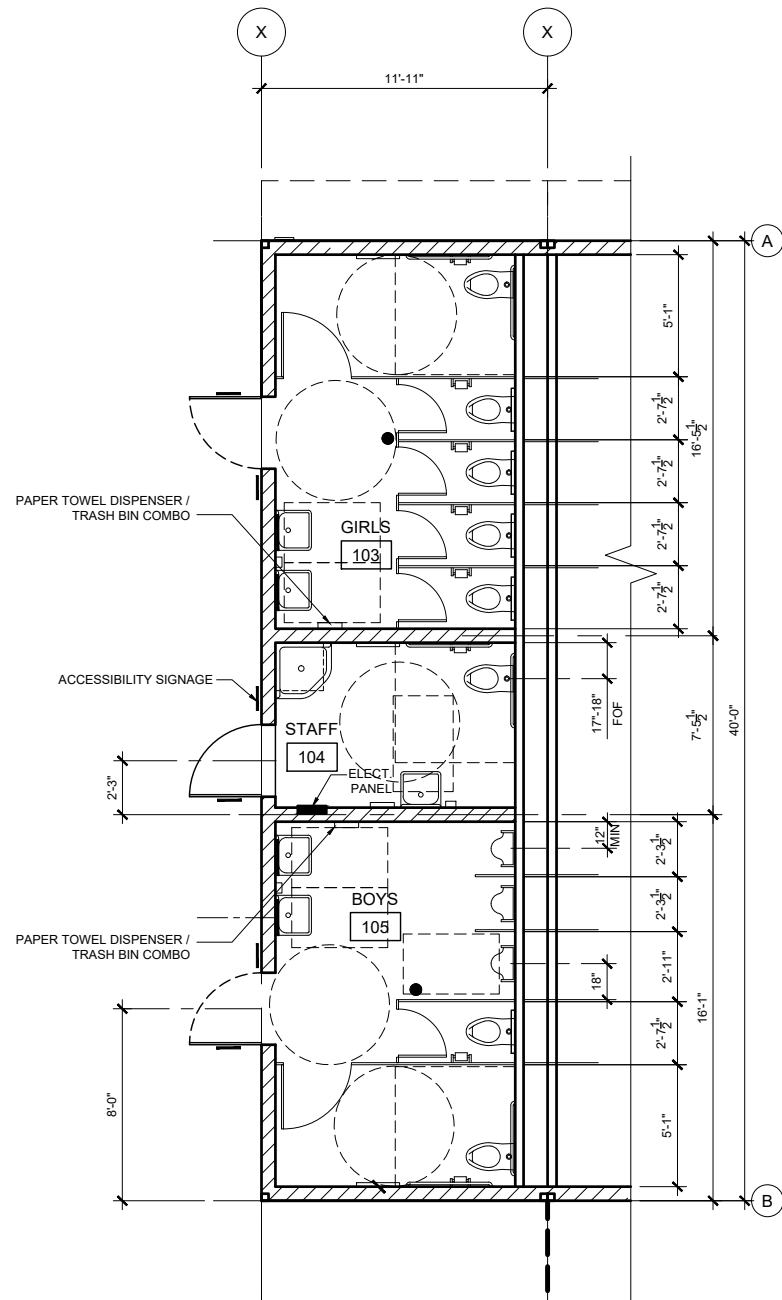

MODEL **"AE"** 12x40 TWO STORY NEW ADD-ON RESTROOM MODULE (FLOOR PLAN)

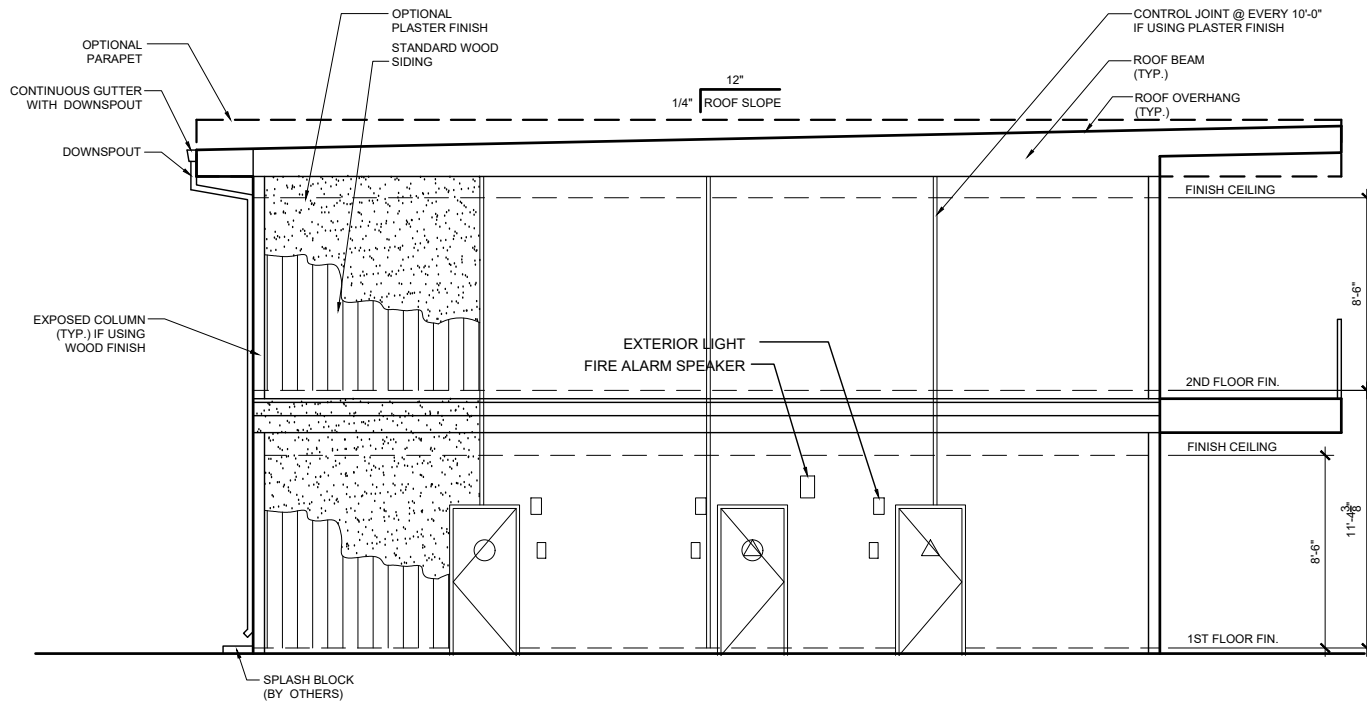
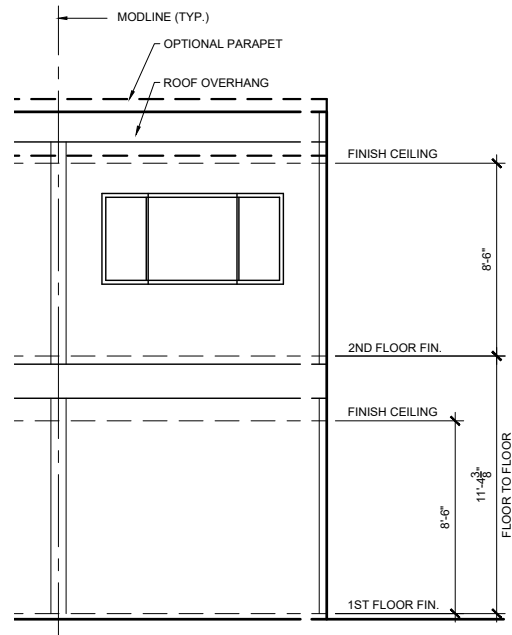

MODEL **"AE"** 12x40 TWO STORY NEW ADD-ON RESTROOM MODULE (EXT. ELEV.)



Elite Modular Leasing & Sales, Inc.

June 1st, 2022 (Updated)
May 12, 2022

Lowell Joint School District
11019 Valley Home Ave
Whittier, CA 90603

Attn: David Bennett (dbennett@ljsd.org)
Assistant Superintendent, Facilities and Operations

Re: Maybrook Site Interim Housing Project Phase II

The following proposal is based upon Lowell Joint SD utilizing the Open Piggyback Contract Bid SSPU, #40-04/2020-21 with Savanna School District as outlined below:

One Year Straight Lease Proposal of (7) 24' x 40' and (4) 48' x 40' Refurbished Classrooms @ Maybrook Phase II

Item I – Pricing (1) 24' x 40' Standard Refurbished Open Classroom (1-year Straight Lease with Wood Foundation and Standard Ramp / Landing)

a)	24' x 40' Annual Rental (Item A-4)	\$ 9,336.00 (per year)
b)	Ramp Landing Annual Rental (Item 544)	\$ 1,573.50 (per year)
c)	Delivery (Item 598 x2)	\$ 1,784.00
d)	Installation (Item A-2A)	\$ 5,140.00
e)	Dismantle (Item A-2B)	\$ 4,091.00
f)	Return (Item 598 x2)	\$ 1,784.00
g)	All Applicable Taxes & Skirting	\$ INCLUDED

Item I-A – Pricing (1) Refurbished 48' x 40' Open Classroom (1-year Straight Lease with Wood Foundation and Standard Ramp–Landing System)

a)	12' x 40', Annual Lease (Item C-4)	\$19,092.00 (per year)
b)	Ramp Landing Annual Rental (Item 544 x2)	\$ 3,148.00 (per year)
c)	Delivery (Item 598 x4)	\$ 3,568.00
d)	Installation (Item C-2A)	\$ 7,868.00
e)	Dismantle (Item C-2B)	\$ 6,819.00
f)	Return (Item 598 x4)	\$ 3,568.00
g)	Sales Tax & Skirting	INCLUDED



Elite Modular Leasing & Sales, Inc.

Item II – Project Totals for a 1-Year Straight Lease (Per Item I above for (7) 24'x40' Classroom & Item 1-A above for (4) 48'x40' Classrooms

Annual rental (Lease payment only)	\$165,330.00 (per year)
Delivery & Installation (Due at delivery)	\$ 94,212.00
Dismantle and Return (Due when buildings returned)	\$ 82,673.00

General Note: Lease payments are annual in advance and will be invoiced along with delivery & installation prior to the scheduled delivery and due upon completion of installation.
Lease Agreements will be provided for signature.
Executed Lease Agreements and Insurance Certificates must be received prior to the start of delivery. Estimated Lease start date is July 1, 2023.

Item III – Additive Alternate – Add NEW standard carpet and base for (7) 24' x 40' & (4) 48 'x 40' Classrooms

- a) Carpet & top set base (Item 161 x 14,400 sf) \$ 68,400.00 (Add)
District may elect to provide carpet and top set base from a local source.

Item IV – Estimated 2022-2023 Critical Path Schedule

- 6-3-22 – Elite Modular receives Signed Proposal or Letter of Intent confirmation to proceed pending final board approval of project
- Mid-Summer – Elite Modular sends DSA Stockpile placeholder drawings to AOR and receives preliminary site plan showing location of classrooms
- Spring 2023 – Elite Modular prepares buildings
- Summer 2023 – Elite Modular delivery & installation (pending actual site readiness by district)

Item V – Inclusions

- DSA Stockpiled approved Rigid Frame building design
- Standard delivery and installation (based on a minimum 2' separation between buildings)
- Installation of Elite Modular's standard ramps and landings
- Prevailing wage site labor rates (Elite Modular and their sub-contractors are registered with the DIR) Standard work week hours (Monday – Friday)
- DSA Stockpile placeholder approved drawings to Architect for DSA relocation to site submittal and approval (CCD will be required to include actual buildings selected and available for 2023 delivery and installation)
- Elite Modular standard wood foundation system (based on a 2-3' building separation)
- Elite Modular standard wall mount HVAC
- Elite Modular standard lights and electrical



Elite Modular Leasing & Sales, Inc.

- Standard NEW carpet and top set base **if ADDITIVE ALTERNATE** is selected
- Exterior color selection per Elite Modular standards (wood siding)
- Elite Modular Standard door hardware for all buildings (per code)
- Refurbished DSA Modular Buildings as available in stock (selection by Elite Modular)

Note: All building hardware, lights, interior and exterior colors, etc. is per Elite Modular standards

Item VI – Exclusions

- DSA submittal, and final site & building approval
- On site / In plant DSA Inspection's and fees as applicable
- DSA Inspections, lab and stockpile fees (Elite Modular to invoice District for reimbursement of applicable fees upon completion of installation)
- AOR / DSA submittal, and final site & building approval
- PLA, PSA or skilled & trained workforce labor compliance agreements
- Weekend, Holiday or non-standard work hours – All work and trades, other than building delivery
- Crane, Shuttle, Rolling, Reverse, Side unload or special unloading of modules (if required due to poor site access)
- **City Permits, Pilot Cars, Traffic Control**
- Access in-out of site for all equipment, trucking & workmen
- Level asphalt or dirt pad for building & ramp with no more than 6" diagonal fall from front to rear of building, starting at the front corner opposite the door, based on Elite Modular wood foundation requirements for minimum and maximum foundation heights
- Transition of ramp toe to grade based on existing site elevations at time of delivery
- Ramp modifications required due to levelness of site pad and direction of slope
- Verification of site pad elevations and marking location of building corners prior to delivery
- Any additional cost related to site delays, pad elevations or readiness of site to receive buildings and start installation
- Custom installation of wood foundation due to access between buildings or pad type other than dirt or asphalt
- 2' or greater filler panels between buildings (or custom size if applicable)
- Connection of site utilities, FA & low voltage systems
- Low voltage systems, components, wire, lighting control and programming (including fire alarm)
- Floor preparation as required and finish flooring (carpet) and base
(Included if additive alternate is selected)
- HVAC, Cabinetry & building signage
- Bonds
- Fire sprinklers or rated building (if required)
- Site wind load requirements exceeding Elite Modular standard wind load design per original DSA approved stockpile drawings based on the stock classrooms selected for this project
- WUI compliant buildings (if required)
- Anything not specifically included is excluded



Elite Modular Leasing & Sales, Inc.

If the above is acceptable, please sign below, provide a PO or an email confirmation to proceed subject to final board approval by 6-3-22 (or sooner) to lock in the schedule as outlined above including the building selection and development of the DSA stockpile drawings package for submittal to the AOR.

Sincerely,
Elite Modular Leasing and Sales, Inc.

Lou Menezes

Lou Menezes
Strategic Account Manager

ACCEPTED _____ DATE _____

BY _____

TITLE _____

ESTIMATED SITE READY DATE _____
(Month/Year)

Jeremy Goldenetz

Jeremy Goldenetz
Director of Business Development
Ca Education

ADDITIVE ALTERNATE #III ADD CARPET & BASE

(Please check one) YES _____ NO _____

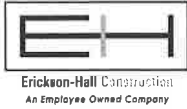

PCCO #001

Erickson-Hall Construction Co.
500 Corporate Drive
Escondido, California 92029
Phone: (760) 796-7700
Fax: (760) 796-7750

Project: 4204 - Meadow Green ES
12025 Grovedale Drive
Whittier, 90604

Prime Contract Change Order #001: Builders Risk Premium

TO:	Lowell Joint School District 11537 Grovedale Dr. Whittier, California 90604	FROM:	Erickson-Hall Construction Co 500 Corporate Drive Escondido, California 92029
PCCO NUMBER/REVISION:	001 / 0	CONTRACT FOR:	4204:Meadow Green ES Prime Contract
DATE CREATED:	6/07/2022	SUBMITTED DATE:	
SCHEDULE IMPACT:		TOTAL AMOUNT:	\$94,950.00

DESCRIPTION:
The following pricing is for the builders risk premium for the Meadow Green ES project.

ATTACHMENTS:
[4204 - Change Order #01 - Builders Risk Premium.pdf](#)

Potential Change Orders in this Change Order

PCO #	Title	Schedule Impact	Amount
002	Builders Risk Premium		\$94,950.00
Total:			\$94,950.00

The original (Contract Sum)	\$5,732,107.00
Net change by previously authorized Change Orders	\$0.00
The contract sum prior to this Change Order was	\$5,732,107.00
The contract sum would be changed by this Change Order in the amount of	\$94,950.00
The new contract sum including this Change Order will be	\$5,827,057.00

Execution of this Potential Change Order will revise the contract value as indicated and may change the contract duration.
Contractor reserves it's right to request additional time and/or cost once the full extent or cumulative nature of the contract change(s) become known.

Ghataode Bannon Architects
760 W 16th Street Unit B
Costa Mesa, California 92627

Lowell Joint School District
11537 Grovedale Dr.
Whittier, California 90604

Erickson-Hall Construction Co
500 Corporate Drive
Escondido, California 92029

SIGNATURE DATE

SIGNATURE DATE

 6/7/2022

SIGNATURE DATE



Erickson-Hall Construction Co.
 500 Corporate Drive
 Escondido, California 92029
 Phone: (760) 796-7700
 Fax: (760) 796-7750

Project: 4204 - Meadow Green ES
 12025 Grovedale Drive
 Whittier, 90604

Potential Change Order #002: Builders Risk Premium

TO:	Lowell Joint School District 11537 Grovedale Dr. Whittier, California 90604	FROM:	Erickson-Hall Construction Co 500 Corporate Drive Escondido, California 92029
PCO NUMBER/REVISION:	002 / 0	CONTRACT:	4204 - Meadow Green ES Prime Contract
REFERENCE:		SUBMITTED DATE:	
CHANGE TYPE:		SCHEDULE IMPACT:	

POTENTIAL CHANGE ORDER TITLE: Builders Risk Premium

POTENTIAL CHANGE ORDER DESCRIPTION:

Builders Risk Premium
 The following pricing is for the builders risk premium for the Meadow Green ES project.

ATTACHMENTS:

#	Cost Code	Description	Type	Amount
1	4204-01 - Electrical & FA	Builders Risk Insurance	Commitment	\$4,932.00
2	4204-02 - Rough Carpentry	Builders Risk Insurance	Commitment	\$9,802.00
3	4204-03 - Painting	Builders Risk Insurance	Commitment	\$4,337.00
4	4204-06 - HVAC	Builders Risk Insurance	Commitment	\$6,290.00
5	4204-08 - Survey	Builders Risk Insurance	Commitment	\$1,250.00
6	4204-09 - Concrete	Builders Risk Insurance	Commitment	\$5,083.00
7	4204-05 - Roofing	Builders Risk Insurance	Commitment	\$15,057.00
8	4204-04 - Plumbing	Builders Risk Insurance	Commitment	\$6,027.00
9	4204-12 - Steel	Builders Risk Insurance	Commitment	\$1,021.00
10	4204-13 - Acoustical Panel Ceilings	Builders Risk Insurance	Commitment	\$507.00
11	4204-14 - Demo	Builders Risk Insurance	Commitment	\$3,700.00
12		Builders Risk Insurance		\$31,527.00
13	100-00 - General Conditions	Contractor OH&P (5%)	Other	\$4,477.00
14	100-00 - General Conditions	Contractor Bond (1%)	Other	\$940.00
			Grand Total:	\$94,950.00

Ghataode Bannon Architects
 760 W 16th Street Unit B
 Costa Mesa, California 92627

Lowell Joint School District
 11537 Grovedale Dr.
 Whittier, California 90604

Erickson-Hall Construction Co
 500 Corporate Drive
 Escondido, California 92029

 SIGNATURE DATE

 SIGNATURE DATE

 SIGNATURE DATE



ERICKSON - HALL
CONSTRUCTION CO.

Change Order Request

School: Meadow Green Elementary School

Project Name: Meadow Green Elementary School - HVAC and REROOF
Project No.: 4204

DSA Application No.: 03-121823

Architect: Ghataode Bannon Architects.
Project Manager: Lowell Joint School District
Contractor: Erickson-Hall Construction Co.

COP No.: 1
Date: 6/7/2022
Reference RFIs: N/A
Reference RFP / Bulletin No.: N/A

DESCRIPTION: The following pricing is for the builders risk premium for the Meadow Green ES project.

Subcontractor Costs (used when work is subcontracted)

Subcontractor	Description	Material	Labor	Equipment	Totals
Alliant Construction Services	Builders Risk Premium	\$ 31,527.00	\$ -	\$ -	\$ 31,527.00
Champion Electric, Inc.	Builders Risk Insurance	\$ 4,932.00	\$ -	\$ -	\$ 4,932.00
Core Contracting, Inc.	Builders Risk Insurance	\$ 9,802.35	\$ -	\$ -	\$ 9,802.35
Cramer Painting, Inc.	Builders Risk Insurance	\$ 4,337.00	\$ -	\$ -	\$ 4,337.00
Elite Air Conditioning, Inc.	Builders Risk Insurance	\$ 6,290.00	\$ -	\$ -	\$ 6,290.00
J&B Surveying, Inc.	Builders Risk Insurance	\$ 1,250.00	\$ -	\$ -	\$ 1,250.00
KAR Construction, Inc.	Builders Risk Insurance	\$ 5,082.80	\$ -	\$ -	\$ 5,082.80
Letner Roofing, Co.	Builders Risk Insurance	\$ 15,057.00	\$ -	\$ -	\$ 15,057.00
Pro-Craft Construction, Inc.	Builders Risk Insurance	\$ 6,027.00	\$ -	\$ -	\$ 6,027.00
South Bay Iron, Inc.	Builders Risk Insurance	\$ 1,021.00	\$ -	\$ -	\$ 1,021.00
Southcoast Acoustical Interiors, Inc	Builders Risk Insurance	\$ 507.00	\$ -	\$ -	\$ 507.00
T 3 Contractors Corp	Builders Risk Insurance	\$ 3,700.00	\$ -	\$ -	\$ 3,700.00
Subtotals		\$ 89,533.15	\$ -	\$ -	\$ 89,533.15
Subcontractor OH and Profit (10%)					\$0.00
Tired Subcontractor Cost					N/A
Subcontractor Profit of Tired Subcontractor (5%)					N/A
Subcontractor Bond (1%)					\$0.00
Subcontractor Subtotal					\$89,533.15
Contractor OH and Profit (5%)					\$4,476.66
Contractor/Subcontractor Subtotal					\$94,009.81
Contractor Bond (1%)					\$940.10
Subcontractor Total + Contractor Mark-ups					\$94,949.91

Contractor Costs (used when work is self-performed)

Contractor	Description	Material	Labor	Equipment	Totals
					\$ -
					\$ -
					\$ -
Subtotals		\$ -	\$ -	\$ -	\$ -
Contractor OH and Profit (10%)					\$ -
Contractor totals					\$ -
Contractor Bond (1%)					\$ -
Contractor Subtotal					\$ -

TOTAL COSTS FOR COP No. 1 \$ 94,950

Contractor Time

TOTAL TIME FOR COP No. 1 0 days

Construction Contingency Errors and Omission Contingency DSA Contingency Gas Line Contingency IDF Contingency

Michael Arnold

From: Jim Castle <jcastle@alliant.com>
Sent: Tuesday, May 24, 2022 4:43 PM
To: Michael Arnold
Cc: Justin Sinnott
Subject: Re: 4204 Meadow Green ES - Insurance
Attachments: image001.jpg; Meadow Green - Builders Risk App.pdf

Michael:

Just got the premium indication on the Builders Risk. Based on the information provided, the premium for the All-Risk excluding Earthquake and flood would be \$31,527 with a \$25,000 deductible.

Optional Coverages:

Earthquake: \$6,879 with a 5% of the values at risk at the time of the loss deductible, subject to a minimum of \$250,000.

Flood: \$1,146 with a \$100,000 deductible.

Your normal insurance loads would cover the cost of the rest of the coverage provided by the OCIP.

Let me know if you have any questions.

Thanks,

Jim Castle



Champion Electric Inc.

3950 Garner Rd.
Riverside, CA 92501
Telephone: (951)-591-5374
Contact: Roger Hernandez
E-mail: Rhernandez@championelec.com

Erickson-Hall Construction Co.

500 Corporate Drive
Escondido, CA 92029
Telephone: 760-803-0077
Contact: Mike Arnold
E-mail: marnold@ericksonhall.com

COST PROPOSAL

CCN # PCO 001
Date: 5/26/2022
Project Name: Meadow Green
Page Number: 1

DETAILS OF PROPOSAL

Description of Work:

OCIP Removal

Conditions:

Upon review of the above stated direction we have identified cost impacts that must be addressed. We are submitting this proposal for your acceptance in response to this direction. This proposal is valid for a period of thirty (30) days upon receipt. As part of this proposal a time extension of one (1) working days are required to be added to our contract to mitigate impacts to the original contract schedule. If a time extension is not acceptable we reserve the right to void this proposal and resubmit a new cost that accounts for acceleration, trade stacking, delays and other issues as may be required. This proposal is based upon information provided by the owner to accomplish completion of this change and we accept no responsibility for inadequate engineering or incomplete information. Excluded from this quote is any demo, patching, repairing, and or painting of finished surfaces unless specifically stated otherwise. We reserve the right to re-evaluate this pricing if conditions or information changes from time of submission to notice to proceed. Upon acceptance of this proposal please expedite our notice to proceed so work may begin as soon as possible. Please contact the undersigned if there are any questions in regards to this proposal.

PROPOSAL TOTAL

\$4,932.00

Signature: _____



1068 LA MIRADA COURT | VISTA, CA 92081
760-683-8308

CHANGE ORDER REQUEST

No: COR 1
Date: 5/26/22

To: **Mike Arnold**
Company: **Erickson Hall Construction**
Address: **500 Corporate Dr**
City: **Escondido, CA 92029**
Phone: **760-796-7700**
Fax:

Job Name: **Meadow Green ES HVAC & Roof Upgrades**
Address: **12025 Grovedale Dr.**
City: **Whittier, CA 90604**

Scope: This is the added cost to change the insurance requirments from OCIP to contractor provided insurance for the project.					
ITEM	DESCRIPTION	QTY	UNIT	UNIT PRICE	TOTAL
1	Project Insurance	1	LS	\$ 8,823.00	\$ 8,823.00
				SUBTOTAL	\$ 8,823.00
				OHP&I 10%:	\$ 882.30
				BOND 1%:	\$ 97.05
				TOTAL:	\$ 9,802.35

GRAND TOTAL: \$ 9,802.35



Cramer Painting Inc.
 4080 Mission Boulevard
 Montclair CA 91763
 909 397-5770

License: 363459

Change Order

Order#: 2

Order Date: 06/01/2022

To: ERICKSON-HALL CONSTRUCTION CO
 500 Corporation Drive
 Escondido CA 92029

Project: 202205
 Meadow Green ES HVAC
 12025 Grovedale Drive
 Whittier CA 90604

The contractor agrees to perform and the owner agrees to pay for the following changes to this contract.

In Reference/Response To:

Sent To:

Add'l Costs for Insurance

Description of Work	Amount Requested
Additional Costs for Insurance	4,337.00

Notes

CO is for adding insurance if no longer OCIP project

Negative changes will lower the overall contract price requiring no additional payment by owner.

Requested Amount of Change 4,337.00

The original Contract Sum was	182,500.00
Net change by previous Change Orders	0.00
The Contract Sum prior to this Change Order	182,500.00
The Contract Sum will be changed by this Change Order	4,337.00
The new Contract Sum including this Change Order will be	186,837.00
The Contract Time will be changed by	0 Days

Owner: _____ Date: _____

Contractor: _____ Date: _____



ELITE AIR CONDITIONING, INC.

May 27, 2022

Attn: Mike Arnold

Erickson-Hall Construction Co., Inc.

JOB NAME: Meadow Green ES HVAC Replacement
LOCATION: Whittier, CA
DESCRIPTION: OCIP
RFI NUMBER:
EACI C.O. #: 2

Our price for the referenced change is as follows:

TOTAL NET CHANGE TO CONTRACT \$ 6,290.00
ADDED DAYS FOR THIS ADDITIONAL WORK -0- Days

This price is based on the usual cost elements such as labor, materials, and markup and does not include any amount for interference, disruptions, rescheduling and change in the sequence of work, delays and / associated acceleration. We expressly reserve the right to submit our request for any of these items should we be faced with performing our work under any of these conditions.

This change proposal is limited to modifications involving our original scope of work. This cost proposal supersedes all previously submitted cost proposals relating to this same work.

This quote is valid for 30 calendar days from the above date and void thereafter.

Work included:

- 1.) Replace OCIP with Contractor insurance.
- 2.) Sales tax as applicable.

Respectfully submitted,
ELITE AIR CONDITIONING, INC.
Nick Evans

LICENSE #985559
DIR # 100000924

OFFICE (951) 272-8960 * FAX (951) 220-7352
PO BOX 7514 * NORCO, CA. 92860

J&B ENGINEERS, SURVEYORS

PLANNING ▼ ENGINEERING ▼ SURVEYING ▼ MAPPING

MINORITY BUSINESS ENTERPRISE (MBE)
Cert No. AZ01675

RCE 29118
DIR Number: 1000005072

SMALL BUSINESS ENTERPRISE (SBE)
Cert. No. 58347

Date: May 27, 2022
Attn: Erickson Hall
Re: Meadow Green ES - Proposal

Page one of one

Good morning,

A. Additional Insurance

1.1 Insurance costs for project duration. \$ 1,250.00

TOTAL ADDED AMOUNT: \$ 1,250.00

Note: The scope of services cannot be changed or reduced without written authorization from J&B Engineers, Surveyors.



CONSTRUCTION, INC.

1306 W. BROOKS STREET * ONTARIO, CA 91762-3611 * BUS: 909-988-5054 * FAX: 909-983-4106 * ST. LIC. #595709

Lowell Joint School District
11019 Valley Home Ave.
Whittier, CA 90603

5/31/2022

Sent Via E-Mail and or Facsimile

ATTN.: Project Manager
RE: Meadow Green ES HVAC & Roof Upgrades
SUB: Change Order Request # 1 - Insurance Premium

KAR Construction, Inc.

Labor		\$	-
Equipment		\$	-
Material		\$	-
Subtotal		\$	-
Contractors Overhead & Profit	10%	\$	-
Contractors Subtotal		\$	5,082.80

Subcontractor Work

Insurance Premium		\$	-
		\$	-
Subcontractors Subtotals		\$	-
Contractors Overhead & Profit	5%	\$	-
Subtotals		\$	-
Subtotal Contractors/ Subcontractors		\$	5,082.80
Bond	0%	\$	-
Total Change Request		\$	5,082.80

K.A.R. Construction, Inc.

Kyle Billings

Kyle Billings, Project Manager



**CHANGE ORDER
PRICING # 8707-1**

Est. 1957
Lic. No. 689961

1490 N GLASSELL STREET
ORANGE, CA 92867
Phone: 714-633-0030 Fax: 714-633-0280

To: ERICKSON - HALL CONSTRUCTION CO.
500 CORPORATE DRIVE,
ESCONDIDO, CA, 92029-1517
Phone: 760/796-7700 Fax: 760/796-7750

Owner/Arch Reference #
Brief Description OCIP
Change Order Type CHANGE IN CONTRACT SCOPE
Submitted Date 5/27/2022

JOB: MEADOW GREEN E.S. ROOF
UPGRADE

Accepted Date
Status PENDING
Approved CO NO

JOB NO: 8707

Item No.	Description	Qty/Unit	Unit Cost	Amount
1	OCIP Cost	1.00 lsum	\$15,057.00	\$15,057.00

Original Contract Sum	\$		\$836,000.00
Pending Change Orders	\$	15,057.00	
Approved Change Orders to Date	\$		0.00
Contract Sum prior to this Change Order	\$		\$836,000.00
Contract Sum increased/(decreased) by this Change Order	\$		\$15,057.00
Contract Sum including this Change Order	\$		\$851,057.00

Approved by: _____

Submitted by: German Gonzalez

Signature: _____ Date: _____

Signature: _____ Date: 05/31/2022



South Bay Iron, INC.
 2751 Lynwood Road
 Lynwood, CA 90262
 Phone: 562-458-4472
 Fax: 562-268-2581
southbayiron@msn.com

Change Order- SB01- 2207

TO: Mike Arnold COMPANY: Erickson-Hall Construction CO.	DATE: 05/31/2022
ADDRESS: 5000 Corporate Drive Escondido, CA. 92029	
ATTN: Mike Arnold	FAX NO: N/A
FROM: Kimberly Ellis	NO OF PAGES: 1
JOB# 2207	Description/ Vendor PO Number: CO
JOB NAME: Meadow Green ES HVAC & Roof Upgrades	JOB LOCATION: 12025 Grovedale Drive Whittier, CA 90604

**NOTE: FAILURE TO RESPOND IN THE GIVEN TIME COULD DELAY THE PROJECT SCHEDULE.
PLEASE RESPOND WITHIN 48 HOURS**

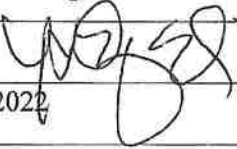
Description: Insurance Cost	
SUBMITTED BY: Kimberly Ellis	Accepted By:
TITLE: Office Manager	TITLE:
SIGNATURE: 	SIGNATURE:
DATE: 05/31/2022	DATE:
COMPANY: South Bay Iron, INC	COMPANY: Rossin Steel, INC
CONTRACT AMOUNT: Time and Material	\$14,068.00
ADD CREDITS (+/-): \$0.00	\$1,021.00
REVISED CONTRACT AMOUNT: Billed upon completion based on full Time and Material	\$15,089.00

Southcoast Acoustical Interiors Inc.
 14980 Hilton Drive
 Fontana, Ca. 92336
 909.428.2600

PROJECT: Meadow Green

CHANGE ORDER SAI# 001

To: Erickson-Hall Construction
500 Corporate Drive
Escondido, Ca. 92029
 Phone:
 Fax:

Date: 5/25/2022
 Job Name: Meadow Green

Description / Building #: _____
Provide Contractors Liability and Workers Compensation insurance in lieu of OCIP

					<u>EXTRA</u>
A.	Material				\$ -
	Fuel				\$ -
	Tax				\$ -
B.	Labor				
Reg.	<u>0</u>	hrs @	\$78.34 /hr	=	<u>\$0.00</u>
	<u>0</u>	hrs @	\$0.00 /hr	=	<u>\$0.00</u>
	<u>0</u>	hrs @	\$0.00 /hr	=	<u>\$0.00</u>
	<u>0</u>	hrs @	\$0.00 /hr	=	<u>\$0.00</u>
C.	Equipment				
	Insurance Contract				\$ <u>507.00</u>
	Insurance Alternate				\$ 1,060.00
D.	Subtotal				\$ <u>1,567.00</u>
E.	Subcontractor's Overhead & Profit - 15%				
	Bond - 1.5%				
F.	TOTAL				\$ <u>1,567.00</u>
Total this change order:					\$ <u>1,567.00</u>

The work covered by this Change Order shall be performed under the terms and conditions of the existing contract, unless otherwise stated. Work will not commence without approval & signature.

Signature / Date

Signature / Date

 Subcontractor

 General Contractor



951-977-8370
 17130 Van Buren Blvd #53
 Riverside, CA 92504
 www.t3contractors.com

CHANGE ORDER REQUEST

T3 Demo COR #: T3-001 Submitted by: CHAD THOMPSON
 T3 Demo Job #: 2022-03-010 Customer Job #: _____ Customer COR Ref: OCIP
 Customer: ERICKSON-HALL CONSTRUCTION Attention: SUMMER
 Phone #: 760.796.7700 Fax #: _____
 Job Name/Address: MEADOW GREEN ELEMENTARY SCHOOL
 Submission Date: 5/27/2022

As of submittal date, this scope of work is: Not Performed

Description of change order work:

ADDED COST TO PROVIDE INSURANCE TO PROJECT PREVIOUSLY COVERED BY OCIP

Date	Category		Amount	Rate	Total
	WORKERS COMP	Base Rate + Labor=	\$ 75,000.00	15%	\$11,250.00
	GENERAL LIABILITY	Contract=	\$ 185,000.00	2%	\$3,700.00

SUBTOTAL \$14,950.00

BOND 1% \$149.50

CHANGE ORDER REQUEST TOTAL: \$15,099.50

By signing below, you authorize T3 Contractors to proceed with the work described above at the amount listed and verify that you are authorized to do so. If the work has already been performed or is in progress, your signature acknowledges that your company authorized T3 Contractors to proceed with the work described above.

Title: _____

Date: _____

**Amendment #1 to Meadow Green Elementary School
Construction Services Agreement
between
Lowell Joint School District and
Erickson Hall Construction Company, Inc.**

THIS AMENDMENT NO. 1 to the Construction Services Agreement, hereinafter referred to as "Agreement," is made and entered into this ____ day of _____, 2022 by and between Lowell Joint School District, hereinafter referred to as "District", and Erickson Hall Construction Company, Inc., hereinafter referred to as "Contractor." All other capitalized terms referenced in the Agreement are unchanged.

INSURANCE

Amendment #1 removes the Owner Controlled Insurance Program (OCIP) from the Construction Services Agreement and places the requirement to procure and maintain insurance on the Contractor. All other references to the OCIP in the Agreement are also deleted and not applicable.

Section 35 of the Construction Services Agreement shall be replaced with the following:

35. INSURANCE

- 35.1 Insurance Requirements. Before the commencement of the Work, the Contractor shall purchase from and maintain in a company or companies lawfully authorized to do business in California as admitted carriers with a financial rating of at least an A status as rated in the most recent edition of Best's Insurance Reports or as otherwise amended in these Contract Documents, such insurance as will protect the District from claims set forth below, which may arise out of or result from the Contractor's operations under the Contract and for which the Contractor may be legally liable, whether such operations are by the Contractor, by a Subcontractor, by anyone directly or indirectly employed by any of them, or by anyone for whose acts any of them may be liable:
1. Claims for damages because of bodily injury, sickness, disease, or death of any person District would require indemnification and coverage for employee claim;
 2. Claims for damages insured by usual personal injury liability coverage, which are sustained by a person as a result of an offense directly or indirectly related to employment of such person by the Contractor or by another person;
 3. Claims for damages because of injury or destruction of tangible property, including loss of use resulting therefrom, arising from operations under the Contract Documents;
 4. Claims for damages because of bodily injury, death of a person, or property damage arising out of the ownership, maintenance, or use of a motor vehicle, all mobile equipment, and vehicles moving under their own power and engaged in the Work;
 5. Claims involving contractual liability applicable to the Contractor's obligations under the Contract Documents, including liability assumed by and the indemnity and defense obligations of the Contractor and the Subcontractors; and
 6. Claims involving Completed Operations, Independent Contractors' coverage, and Broad Form property damage, without any exclusions for collapse, explosion, demolition, underground coverage, and excavating. (XCU)
 7. Claims involving sudden or accidental discharge of contaminants or pollutants.

35.2 Subcontractor Insurance Requirements. The Contractor shall require its Subcontractors to take out and maintain similar public liability insurance and property damage insurance required under this Article in like amounts. A “claims made” or modified “occurrence” policy shall not satisfy the requirements of this Article without prior written approval of the District.

35.3 Additional Insured Endorsement Requirements. The Contractor shall name, on any policy of insurance required under this Article, the District, Architect, Inspector, the State of California, their officers, employees, agents and independent contractors as additional insureds. Subcontractors shall name the Contractor, the District, Architect, Inspector, the State of California, their officers, employees, agents and independent contractors as additional insureds. The Additional Insured Endorsement included on all such insurance policies shall be an ISO CG 20 10 (11/85); or an ISO CG 20 10 (10/01) and CG 20 37 (10/01); or an ISO CG 20 10 (10/01) and CG 2038 (04/13) or their equivalent as determined by the District in its sole discretion, and must state that coverage is afforded the additional insured with respect to claims arising out of operations performed by or on behalf of the insured. If the additional insureds have other insurance which is applicable to the loss, such other insurance shall be on an excess or contingent basis. The insurance provided by the Contractor pursuant to this Article must be designated in the policy as primary to any insurance obtained by the District. The amount of the insurer’s liability shall not be reduced by the existence of such other insurance.

35.4 Specific Insurance Requirements

35.4.1 Contractor shall take out and maintain and shall require all Subcontractors, if any, whether primary or secondary, to take out and maintain:

35.4.2 Comprehensive General Liability Insurance with a combined single limit per occurrence of not less than \$2,000,000.00 or Commercial General Liability Insurance (including automobile insurance) which provides limits of not less than:

1.	Per occurrence (combined single limit)	\$2,000,000.00
2.	Project Specific Aggregate (for this Project only)	\$2,000,000.00
3.	Products and Completed Operations	\$2,000,000.00
4.	Personal and Advertising Injury Limit	\$2,000,000.00

35.4.3 Insurance Covering Special Hazards. The following Special hazards shall be covered by riders or riders to above mentioned public liability insurance or property damage insurance policy or policies of insurance, in amounts as follows:

1.	Automotive and truck where operated in amounts	\$1,000,000.00
2.	Material Hoist where used in amounts	\$1,000,000.00
3.	Explosion, Collapse and Underground (XCU coverage)	\$1,000,000.00
4.	In addition, provide Excess Liability Insurance coverage in the amount of Five Million Dollars (\$5,000,000.00).	

35.5 Workers’ Compensation Insurance. During the term of this Contract, the Contractor shall provide workers’ compensation insurance (not less than \$1M) for all of the Contractor’s

employees engaged in Work under this Contract on or at the Site of the Project and, in case any of the Contractor's Work is subcontracted, the Contractor shall require the Subcontractor to provide workers' compensation insurance (not less than \$1M) for all the Subcontractor's employees engaged in Work under the subcontract. Any class of employee or employees not covered by a Subcontractor's insurance shall be covered by the Contractor's insurance. In case any class of employees engaged in Work under this Contract on or at the Site of the Project is not protected under the Workers' Compensation laws, the Contractor shall provide or cause a Subcontractor to provide adequate insurance coverage for the protection of those employees not otherwise protected. The Contractor shall file with the District certificates of insurance and in comply with Labor Code § 3700.

35.6 Builder's Risk/All Risk

35.6.1 *Course-of-Construction Insurance Requirements.* The Contractor, during the progress of the Work and until final acceptance of the Work by District upon completion of the entire Contract, shall maintain Builder's Risk, Course of Construction or similar first party property coverage issued on a replacement value basis consistent with the total replacement cost of the structures where work is being performed inclusive of all Work for the Project included within the Contract Documents. Coverage is to insure against all risks of accidental direct physical loss, and must include, by the basic grant of coverage or by endorsement, the perils of vandalism, malicious mischief (both without any limitation regarding vacancy or occupancy), fire, sprinkler leakage, civil authority, sonic boom, earthquake, flood, collapse, wind, lightning, smoke and riot. The coverage must include debris removal, demolition, increased costs due to enforcement of building ordinance and law in the repair and replacement of damage and undamaged portions of the property, and reasonable costs for the Architect's and engineering services and expenses required as a result of any insured loss upon the Work and Project which is the subject of the Contract Documents, including the underlying structure where Work is being performed, completed Work and Work in progress, to the full insurable value thereof. Such insurance shall include the District and the Architect as additional named insureds, and any other person with an insurable interest as designated by the District.

The Contractor shall submit to the District for its approval all items deemed to be uninsurable. The risk of the damage to the Work due to the perils covered by the "Builder's Risk/All Risk" Insurance, as well as any other hazard which might result in damage to the Work, is that of the Contractor and the surety, and no claims for such loss or damage shall be recognized by the District nor will such loss or damage excuse the complete and satisfactory performance of the Contract by the Contractor.

35.7 Fire Insurance. Before the commencement of the Work, the Contractor shall procure, maintain, and cause to be maintained at the Contractor's expense, fire insurance on all Work subject to loss or damage by fire. The amount of fire insurance shall be sufficient to protect the Project against loss or damage in full until the Work is accepted by the District.

35.8 Other Insurance. The Contractor shall provide all other insurance required to be maintained under applicable laws, ordinances, rules, and regulations.

35.9 Proof of Insurance. The Contractor shall not commence Work nor shall it allow any Subcontractor to commence Work under this Contract until all required insurance and

certificates have been obtained and delivered in duplicate to the District for approval subject to the following requirements:

35.9.1 Certificates and insurance policies shall include the following clause:

1. "This policy shall not be non-renewed, canceled, or reduced in required limits of liability or amounts of insurance until notice has been mailed to the District. Date of cancellation or reduction may not be less than thirty (30) days after the date of mailing notice."
2. Certificates of insurance shall state in particular those insured, the extent of insurance, location and operation to which the insurance applies, the expiration date, and cancellation and reduction notices.
3. Certificates of insurance shall clearly state that the District and the Architect are named as additional insureds under the policy described and that such insurance policy shall be primary to any insurance or self-insurance maintained by District.
4. The Contractor and its Subcontractors shall produce a certified copy of any insurance policy required under this Article upon written request of the District.

35.10 Compliance. In the event of the failure of Contractor to furnish and maintain any insurance required by this Article 34, the Contractor shall be in default under the Contract. Compliance by Contractor with the requirement to carry insurance and furnish certificates or policies evidencing the same shall not relieve the Contractor from liability assumed under any provision of the Contract Documents, including, without limitation, the obligation to defend and indemnify the District and the Architect.

35.11 No Waiver Created through Payments. The making of any payments under this CSA or the Sublease shall not be construed as creating an insurable risk interest by or for the District or be construed as relieving the Contractor or his Subcontractors of responsibility for loss from any direct physical loss, damage, or destruction occurring prior to Completion of the Project.

35.12 Waiver of Subrogation. Contractor waives (to the extent permitted by law) any right to recover against the District for damages to the Work, any part thereof, or any and all claims arising by reason of any of the foregoing, but only to the extent that such damages and/or claims are covered by property insurance and only to the extent of such coverage (which shall exclude deductible amounts) by insurance actually carried by the District.

The provisions of this section are intended to restrict each party to recovery against insurance carriers only to the extent of such coverage and waive fully and for the benefit of each, any rights and/or claims which might give rise to a right of subrogation in any insurance carrier. The District and the Contractor shall each obtain in all policies of insurance carried by either of them, a waiver by the insurance companies thereunder of all rights of recovery by way of subrogation for any damages or claims covered by the insurance.

35.13 Performance and Payment Bonds

35.13.1 *Bond Requirements*. Prior to commencing any portion of the Work, the Contractor shall furnish separate payment and performance bonds for its portion of the Work which shall cover 100% faithful performance of and payment of all obligations arising under the Contract Documents and/or guaranteeing the payment in full of all claims for labor performed and

materials supplied for the Work. All bonds shall be provided by a corporate surety authorized and admitted to transact business in California as sureties.

To the extent, if any, that the Contract Price is increased in accordance with the Contract Documents, the Contractor shall, upon request of the District, cause the amount of the bonds to be increased accordingly and shall promptly deliver satisfactory evidence of such increase to the District. To the extent available, the bonds shall further provide that no change or alteration of the Contract Documents (including, without limitation, an increase in the Contract Price, as referred to above), extensions of time, or modifications of the time, terms, or conditions of payment to the Contractor will release the surety. If the Contractor fails to furnish the required bonds, the District may terminate the Contract for cause.

- 35.13.2 *Surety Qualification.* Only bonds executed by admitted Surety insurers as defined in Code of Civil Procedure § 995.120 shall be accepted. Surety must be a California-admitted surety and listed by the U.S. Treasury with a bonding capacity in excess of the Project cost.
- 35.13.3 *Alternate Surety Qualifications.* If a California-admitted surety insurer issuing bonds does not meet these requirements, the insurer will be considered qualified if it is in conformance with § 995.660 of the California Code of Civil Procedure and proof of such is provided to the District.
- 35.13.4 Contractor is hereby authorized to obtain a performance and payment bond from any Subcontractors selected by Contractor at its discretion and cost. Any bonds required by this subsection shall comply with the requirements set forth above.

District

Contractor

By: _____
Signature

By: _____
Signature

Jim Coombs
Print Name

Print Name

Superintendent
Title

Title



Mr. David Bennett
Lowell Joint School District
Facilities Development & Planning
11019 Valley Home Ave
Whittier, CA 90603

June 6, 2022

Subject: Proposal for Limited Geotechnical Study
Proposed Seismic of Building C
Rancho Starbuck Intermediate School
16430 Woodbrier Drive, Whittier, CA 90604
(Proposal No. 22-0384)

Dear Mr. Bennett:

Koury Engineering & Testing, Inc. (Koury) is pleased to present this proposal to perform a geotechnical study for the proposed seismic retrofitting of the one-story Building C located in the western part of the campus between Buildings A and B. The purpose of our study is to evaluate the subsurface soil conditions at the site in order to provide geotechnical recommendations for design and construction of the proposed improvements per CGS & DSA requirements. The following sections describe our understanding of the project, our proposed scope of services and fee, and an estimated schedule for completion of our study. Our proposal is based on the following:

- YourRequest for Proposal No. 2122-13, dated October 8, 2021;
- A Drawing showing the outline of the building to be retrofitted provided by GHATAODE BANNON ARCHITECTS, LLP; and
- Similar past projects performed for various School Districts under CGS & DSA jurisdictions.

BACKGROUND AND PROJECT UNDERSTANDING

Based on the RFP, the District is planning to seismically upgrade Building C at Rancho Starbuck Intermediate School. The improvement at the site may include adding new foundations, new slab on grade, moment frames, walls, ADA ramps, and pavement.

Based on our review of the available geologic information, we anticipate the subsurface conditions at the site to consist of artificial fill underlain by formational material consisting of siltstone, sandstone, shale, and conglomerate. The historical high groundwater level has been mapped at a depth of about 10 feet in the eastern portion of the campus, outside the building footprint. The building footprint is not reported as being located within an area identified by the State of California as subject to liquefaction hazard.

For building design or retrofitting, Site-Specific Ground Motion Studies are normally required when the seismic parameter S_1 is 0.75 or greater. For this site, the value of S_1 is 0.605 and, therefore, is not subject to CGS requirements for Site-Specific Ground Motion Study. The site modified peak ground acceleration PGAM is 0.81g.

Architectural and structural design details were not available for the preparation of this proposal. For the purpose of this proposal, we have assumed maximum column loads of about 30 kips and wall loads on the order of 2 kips per lineal foot.



Rancho Starbuck Intermediate School SI

SCOPE OF SERVICES AND METHODOLOGY

Based on our understanding of the project and the existing site conditions, Koury proposes the following tasks to provide geotechnical recommendations for the design and construction of the proposed improvements.

Task 1 – Background Review

We will review geologic maps and existing studies and project plans covering the site. We will also perform a site reconnaissance to observe existing access conditions and select proposed borings locations.

We will mark the locations of our proposed borings and notify Underground Service Alert of our intent to dig in accordance with State law. We request that all available information identifying the type and location of utility lines and other man-made objects beneath the proposed improvement areas be provided to us at least one week prior to marking our boring locations. Furthermore, we request that a maintenance supervisor or someone familiar with the layout of utilities meet with us to review the proposed exploration test locations.

A reasonable effort will be made during the marking of the exploration point locations to avoid utility line conflicts. However, our scope of work does not include time for the repair and/or replacement of utility lines that may be accidentally broken and/or damaged by our drilling activities that is not the result of our negligence. Koury will not be responsible for the repair of utilities damaged by our field activities, if the utilities are not marked or located differently than shown on the plans.

Task 2 – Field Exploration

Based on the plan provided to us for this proposal, we understand that three borings have been requested, and one of these borings will need to extend to a depth of 50 feet. Based on our review of the site google images, it does not appear that the boring locations are readily accessible with track or truck-mounted auger drilling equipment. We are, therefore, proposing to drill the three borings using hand-held drilling equipment. The three borings will be drilled to refusal of the hand auger equipment or 15 feet, whichever comes first. In addition, we propose to drill one boring as close to the building as possible using either track or truck-mounted hollow stem auger equipment; this boring will be drilled to a depth of 50 feet or refusal, whichever occur first.

Our typical sampling intervals will be 2, 5, 8 and 10 feet, then every 5 feet thereafter to full depths explored. The number of blows necessary to drive a Standard Penetration Test (SPT) sampler and/or a modified-California sampler will be recorded. The depth to groundwater will be measured at the completion of drilling, if encountered.

At the completion of drilling, each hole will be backfilled and then patched with ready-to-use concrete mix (Quickrete), where applicable. Koury's subcontractor will clean up the exploration locations by sweeping the boring areas. During the field investigation, Koury will use traffic cones, signages, and other control signs to protect the work area and for public safety.

Task 3 - Laboratory Testing

Laboratory tests will be performed on selected soil samples to evaluate the physical and engineering characteristics of the subsurface soils. The laboratory tests to be performed may include the following:

- Moisture content and unit weight;
- #200 sieve wash and/or gradation for soil classification;
- Direct shear to evaluate the shear strength of the soil;



Rancho Starbuck Intermediate School SI

- Expansion index or plasticity index/Atterberg Limits, if clay is encountered at shallow depth;
- R-value testing, if applicable;
- Consolidation to evaluate the compressibility of the soils; and
- Corrosivity/resistivity and pH for evaluation of the corrosion potential.

The selected type and frequency of laboratory testing will depend on the nature of the soils encountered, and the density and cohesion of the soils as determined by the blow counts recorded during sampling.

Task 4 – Geotechnical Engineering Analysis and Report Preparation

The results of our field exploration, laboratory tests, engineering analysis will be summarized in a written report prepared under the supervision of a Registered Geotechnical Engineer and/or Certified Engineering Geologist. We can provide an electronic copy (pdf file) of a draft site data report in general compliance with CGS Note 48 and with DSA IR-4 & IR 4.13 for review and comments, if requested. Upon receipt of any review comments, we will review the comments and incorporate them into our final report, where applicable. One pdf copy of the final report will be provided for your use. We anticipate that our report will include the following items

- Vicinity map and site plan showing the approximate boring locations;
- Geology and Fault Location Maps;
- Logs of borings;
- Results of laboratory tests;
- Discussion of general site surface and subsurface conditions, including groundwater;
- Evaluation of known active faults and potentially active faults near the site;
- Evaluation of the suitability of the site for rehabilitation from a geotechnical standpoint;
- Evaluation of the potential for liquefaction;
- Seismic hazard analysis to estimate the earthquake magnitude, peak ground acceleration and provide CBC seismic factors;
- Recommendations for site preparation, earthwork, fill and compaction requirements;
- Temporary excavation recommendations and shoring, if applicable;
- Recommendations for shallow foundations, including allowable bearing pressures, lateral pressures and embedment depths;
- Recommendations for support of slab-on-grade;
- Anticipated total and differential settlements due to static and seismic loads;
- Evaluation of onsite soil suitability and recommendations for import material, if applicable;
- Preliminary recommendations for pavement design and construction;
- Preliminary evaluation of the expansion and corrosion potential of onsite soils, and mitigation recommendations where applicable;
- Review of plans and specifications related to geotechnical engineering; and
- Response to CGS and DSA review comments

ASSUMPTIONS

The scope of work described above and the associated fee assumes the following:

- Permission to access the site will be provided and the site is accessible with drilling equipment;
- Utility plans for the site will be provided to Koury prior to marking the locations of the borings;
- Cost estimate does not include delays in the field, other than delays caused by Koury, including “right-of-entry” for Koury, and its subcontractors in order to complete the work proposed herein;
- Drilling of the borings can be performed during daylight hours, and from Monday through Friday between 7:00 a.m. and 5:00 p.m.;



Rancho Starbuck Intermediate School SI

- If the field work needs to be performed on weekends, there will be an additional fee. A separate line item for this service is provided in the Fee section of the proposal;
- In accordance with the law and industry standards, Koury will notify Underground Service Alert (811 USA) and have public utilities marked prior to digging. Koury will take reasonable precautions to avoid damage to these marked services (utilities). Koury cannot be liable for unidentified (hidden) underground utilities. Koury does not assume or accept responsibility for damage done to unidentified underground utilities while performing their services. Underground utilities include but are not limited to: natural gas or propane lines, irrigation/sprinkler lines, electrical power, sewage, communication, oil, water and storm drains. We understand C Below has been successful in locating many utilities not identified by DigAlert, you could call 1-888-90-BELOW for further information.
- No analysis for hazardous material content or groundwater testing is included as part of this proposal;
- No percolation testing is included;
- No Site-Specific Ground Motion Study is included except as an option;
- The fee proposal for Phase I assumes participation in no more than 1 meeting for coordination with project design team;
- The fee for plan review is provided as a separate line item;
- Post-report services are not included except for report clarification; and
- Except for report clarification and responses to CGS and DSA comments, additional work that may be requested is not included.

SCHEDULE

Koury is prepared to begin the fieldwork about two weeks following the notice to proceed, thus allowing time to mark and clear the exploration point locations and to mobilize subcontractors for borings. The fieldwork is anticipated to take about two days to complete. Our report should be available approximately five weeks following the completion of the fieldwork. The schedule can be accelerated if needed to meet specific District deadlines.

FEE

Koury proposes to provide the services described above for a fixed fee as described below. Our fee estimate can be roughly broken down as follows:

Phase I - Geotechnical Study

Task/ Description	Fee
Field Exploration – 4 borings (subcontracted)	\$ 3,550.00
Field Services - boring layout, utility clearance, and field personnel	\$ 1,550.00
Laboratory Testing	\$ 2,200.00
Engineering Analyses	\$ 950.00
Report Preparation (draft and final)	\$ 3,850.00
Response to CGS/DSA Review Comments	\$ 700.00
Review of Plans and Specifications (not exceeding 2 sets of review)	\$ 650.00
Total	\$ 13,450.00



Rancho Starbuck Intermediate School SI

Optional Tasks

Task/ Description	Fee
Additional charge for field exploration if done on weekends	\$ 1,400.00
Site Specific Ground Motion Study	\$ 2,600.00

CLOSURE

Our work will be performed in a manner consistent with that level of care and skill ordinarily exercised by other members of Koury's profession practicing in the same locality, under similar conditions and at the date the services are provided. Our scope of work does not include environmental assessment or environment sampling.

In accordance with the law and industry standards, Koury Engineering & Testing, Inc. ("KET") will notify Underground ServiceAlert (811 DigAlert) and have public utilities marked prior to digging. KET will take reasonable precautions to avoid damage to these marked services (utilities). KET cannot be liable for unidentified (hidden) underground utilities. KET does not assume or accept responsibility for damage done to underground utilities while performing their services. Underground utilities include but are not limited to: natural gas or propane lines, sprinkler lines, electrical power, sewage, communication, oil, water and storm drains. Damage and/or repair will be at owner's expense.

We understand C Below has been successful in locating many utilities not identified by DigAlert , you could call 1-888-90-BELOW for further information.

If you have any questions, please feel free to contact me.

Regards,

Koury Engineering & Testing, Inc.

Holly Kirk
Business Development Manager
909.573.6718
hollyk@kouryengineering.com



KOURY
PASSION INTEGRITY QUALITY

Rancho Starbuck Intermediate School SI

General Conditions

1. Indemnification

In the event of any claim against KET by any party other than Client, Client agrees to hold KET, including its shareholders, officers, directors, employees, agents, and representatives, free and harmless of any from, and to indemnify and defend KET against, any and all liability, claims, causes of action, demands, judgments, losses, damages, expenses, or cost (including, but not limited to, all costs and fees of litigation) of every kind, nature and description, including but not limited to, any and all demands arising by reason of injury or death to person or damage to property, real or personal, including loss of use thereof, economic loss or loss damages otherwise arising directly or indirectly out of the obligations herein undertaken, or out of operations conducted by client, however caused or alleged to have been caused, even if due to acts, errors, omissions or negligence, active, affirmative or passive of KET, except for such losses or damages arising out of or caused by the sole negligence or willful misconduct of KET.

2. Limitation of Liability

Client and KET agree to limit the liability, including but not limited to, for consequential damages, of KET, including its shareholders, officers, directors, employees, agents and representatives for any acts, errors, omissions, breaches of contract, or negligence, active, affirmative, passive, concurrent or sole, on the part of KET, arising directly or indirectly from the performance of the professional services under this agreement, to Client to \$10,000 or an amount equal to KET's fee, whichever is greater.

Client agrees and understands that, in order to provide the professional services requested at the agreed upon fees, this agreement does not provide full liability of KET losses or damages which may arise directly or indirectly under this agreement. Client further understands that should Client require KET to accept exposure to greater liability under this agreement, Client has the opportunity to negotiate in advance a higher limitation of liability, or to eliminate entirely such limit of liability, but that the higher fees commensurate with this higher risk of liability to KET shall be subject to agreement. Client agrees that this provision limiting KET's liability cannot be modified, altered, or varied except by written instrument signed by Client and KET.

Client understands and agrees that KET is not an insurer; that this agreement does not provide Client with insurance coverage by KET or anyone acting on its behalf; that all fees hereunder are based solely on the value of the professional services to be provided by KET; that insurance, if any, shall be obtained by Client at Client's sole expense

3. Warranty of Authority to Sign

The person signing this contract warrants that he/she has the authority to sign on behalf of the client for whose benefit Consultant's services are rendered. If such person does not have such authority, he/she is personally liable for all breaches of this contract and that, in any action against him/her of such warranty, a reasonable attorney's fee shall be included in judgment rendered.

4. Dominant Terms

The terms and conditions of this Agreement shall take precedents over any terms and conditions which may appear in Client's purchase order, approval or acceptance. Any terms and conditions of Client's purchase order, approval or acceptance which are not identical to the terms and conditions of this Agreement are null and void, are not part of the agreement between KET and Client and are not binding upon KET. The terms and conditions of this agreement may not be varied or changed, nor any of its provisions waived, except by written agreement, signed by an authorized representative of KET. If Client's terms are different, a statement of worth will be provided with updated terms and conditions.

Charges For Service and Contract Terms Prevailing Wage Projects

The charges for services and General Terms and Conditions set forth below will govern the provision of services and will constitute the contract terms between the Owner or Owner's Representative (Client) and Koury Engineering and Testing, Inc (KET) unless the Client and KET have executed a written contract with respect to such services, in which case the terms and provisions of the written contract shall control.

1. Anticipated Costs

- 1.1. KET estimates a budget to assist the client with code required inspections and testing based upon information provided by the client. KET's ability to perform within the estimated budget depends heavily on the accuracy of the information provided, as well as the cooperation and assertiveness of client's management staff.
- 1.2. Project actual budget totals may vary. Estimated budget hours are based on 40 hours a week, 8 hours a day, Monday-Friday. Client shall monitor the percentage of work remaining to assure inspections and testing is not greater than the estimated budget and adjusts the contractor's labor and scheduling to maintain the work completion schedule.
- 1.3. A call scheduling inspection and testing beyond KET's estimated budget is deemed acceptance that Client will pay for additional services beyond KET's estimated budget.
- 1.4. Client recognizes and agrees that any "anticipated costs," "budget estimates," or the like that may be prepared by KET are NOT "guaranteed maximums," "lump sums;" or "not-to-exceed totals". Client will be invoiced for all work performed and only for work performed based on KET's working conditions and hours as an attachment to their contract.
- 1.5. Client recognizes, if shop steel fabrication service is required, KET's estimate of hours, unless otherwise noted, is for one steel fabrication facility only.
- 1.6. Additionally, any weekly overtime hours, Saturday or Sunday, double shift, and/or night shift differential for shop steel inspection are NOT included in KET's proposal.
- 1.7. An Administration fee of 4% will be applied on monthly invoice and a 3% credit card processing fee is applied when invoice is paid by credit card.

2. Minimum Charges

- 2.1. 2-hour minimum: Inspector shows up; no work requested or performed.
- 2.2. 4-hour minimum: 1 to 4 hours.
- 2.3. 8-hour minimum: Work over 4 hours.
- 2.4. NOTE: Less than 24 hour call-out notice may necessitate premium charges.

3. Working Hours

- 3.1. Regular Time: First 8 hours, Monday-Friday
- 3.2. Time and One-Half Hours: Hours over 8 -12 Monday-Friday, and first 12 Hours on Saturday; Double Time: All hours worked after 12, Monday-Saturday, Sunday, and Holidays.
- 3.3. KET observes the following holidays: New Year's Day, Memorial Day, Independence Day, Labor Day, Veterans Day, Thanksgiving Day, Day after Thanksgiving, and Christmas Day.
- 3.4. Overtime hours shall be billed in one hour increments. One half (.5) hour of overtime is billed as one (1) hour of overtime.
- 3.5. NOTE: Day shift hours are between 5:00am and 5:00pm.

4. Shift Differential

- 4.1. Second (Swing Shift)-Eight (8) hours will be charged for 7.5 hours worked. Time worked in excess of 7.5 hours will be billed at time and one-half rate.
- 4.2. Third (Graveyard Shift)-Eight (8) hours will be charged for 7 hours worked. Time worked in excess of 7 hours will be billed at time and one-half times the hourly rate.

5. Travel Time and Mileage

- 5.1. Travel time costs for soil monitoring and soil technicians will be invoiced at regular contracted billing rate; overtime applies.
- 5.2. Mileage costs for soil monitoring and soil technicians will be invoiced at \$0.75 per mile.
- 5.3. Portal-to-Portal travel time and mileage costs will apply for Engineers, Site Supervisors, Technicians (including Utility Locating and NDT) and Consultants at the contracted billing rate, mileage will be invoiced at \$0.75 per mile. Portal-to-Portal is recognized as KET's office to work site and return.
- 5.4. For projects in excess of 100 miles from a KET office, travel time, mileage and subsistence allowance will be charged in addition to hours worked from KET's closest office.

6. Scheduling and Cancellations

- 6.1. A 24-hour notice is required when scheduling an inspection or technician. If same day scheduling or scheduling after 2:00pm the preceding day is requested, a premium expedite fee of \$75 per inspector or technician will apply.
- 6.2. If inspection service is not canceled with KET's dispatch department by 2:00pm for the next day for ICC, LA City or LA County jurisdictions, a premium cancellation fee will apply at the rate of \$75 per inspector or technician.

7. Expedite Fee

- 7.1. All expedited and rush requests for, lab work, test results, report reviews, etc. will be charged an expedite fee at 1.5 times the Master Fee Schedule of Rates.

8. Escalation Clause

- 8.1. The prices quoted below for all services will change July 1st each year in accordance with the wage listed by the Director of Industrial Relations which is tied to Operating Engineers Local 12. The charges for services set forth in this Schedule of Fees will be adjusted by changes in our general administrative and overhead expenses each year thereafter. These adjusted charges shall become the agreed upon basis for charges by Koury to the Client.

9. Certified Payroll

- 9.1. Certified payroll requests will have a processing fee applied for each project, billed at \$150 per payroll week.

10. Laboratory Testing

- 10.1. A soils sample pick-up charge will be invoiced at regular billing rate with a 2-hour minimum.
- 10.2. Unless otherwise agreed, all samples or test specimens will be disposed of or destroyed upon completion of testing. If Client requires samples to be retrieved or stored, arrangements can be made at an additional cost. Quotation will be provided for such services.
- 10.3. Samples requiring more than one person to handle due to oversize or weight, will incur an extra handling charge. Quotation will be provided for such services.

11. Reimbursable Expenses

- 11.1. Outside Services performed by others and direct costs incurred on the Client's behalf, will be charged at cost plus 20%.
- 11.2. Project exclusive equipment or material will be invoiced at cost plus 20%.
- 11.3. Business licenses or inspection jurisdiction fees for project specific requirements will be invoiced at cost plus 20%.
- 11.4. If free parking is not available, parking charges will be charged to the Client at cost plus 20%.
- 11.5. Incidentals, including airfare, car rental, food, lodging, and parking, will be charged at cost plus 20% for out of area inspections unless provided by Client.

12. Terms of Payment

- 12.1. Client agrees invoices rendered for professional or technical services will be prepared bi-weekly and are due upon presentation.
- 12.2. All invoice errors or necessary corrections shall be submitted to KET within Fifteen (15) days of receipt of invoice; thereafter customer acknowledges invoice is correct and valid for payment due to KET.
- 12.3. Invoices will be deemed delinquent if not paid within thirty (30) days from date of invoice, and will be subject to a late payment charge of 1.5% of the invoice total for each month unpaid.
- 12.4. In the event, an attorney is needed for collection, Client is responsible for reimbursing attorney's fees and or court costs.
- 12.5. KET reserves the right to terminate services to a client without notice if client's account is past due more than thirty (30) days. Upon such termination of services, the entire amount accrued for all services performed shall immediately become due and payable to KET. Client waives any and all claims against KET, its subsidiaries, affiliates, servants, and agents in connection with termination of work/services pursuant to this agreement.

13. Insurance

- 13.1. KET carries all insurance required by law. Additional costs for waiver of subrogation, extra insurance certificates, coinsurance endorsements or additional insurance will be invoiced to the client at \$150 each.

14. Final Reports

- 14.1. When final report is required, KET must first review all inspection and material testing reports; KET will address and clear up any unresolved issues on these reports, typically with the Architect or Engineer of Record.
- 14.2. Depending on the project complexity and length of KET services performed, this process can require a minimum of ten (10) business days for completion. If there are exceptions, the final report review can require an extended length of time to complete.
- 14.3. Report fee is as negotiated per contract. An additional charge will incur for every report processed per permit number associated with the project. Engineer will be billed at \$190 per hour.
- 14.4. Client is required to send KET written request for all final project reports via fax, email, or US mail.
- 14.5. Final reports are as stated, but not limited to: Final Material Compliance Report and Final Grading / Compaction Report.
- 14.6. KET will release final report to client once account, including cost of final report, is paid in full.

15. Service Authorization

- 15.1. Verbal request will be considered authorization to perform billable work. Client shall designate member(s) of staff who have authority to request services and notify KET in writing to their authorized representative. Otherwise all service requests are billable

16. Proposal Valid Duration

- 16.1. Proposed Master Fee Schedule of Rates, Terms & Conditions and General Conditions stated within are valid for 30 days from proposal date.



KOURY
PASSION INTEGRITY QUALITY

Rancho Starbuck Intermediate School SI

The Master Fee Schedule of Rates, Terms & Conditions and General Conditions set forth will be governed by State of California laws, provision of services and will constitute as contract agreement between Client and Koury Engineering & Testing, Inc. (KET) unless the Client and KET have executed a written contract with respect to such services, in which case the written contract shall control.

Client's Signature

Koury Representative Signature

Title

Title

Date

Date



KOURY
PASSION INTEGRITY QUALITY

Corporate Office:
14280 Euclid Ave
Chino, CA 91710

Branch Office:
17800 S. Main St. Ste. 302
Gardena, CA 90248



LOWELL JOINT SD
PURCHASE ORDER DETAIL REPORT
 BOARD OF TRUSTEES MEETING 06/27/2022

FROM 05/01/2022 TO 05/31/2022

<u>PO NUMBER</u>	<u>VENDOR</u>	<u>PO TOTAL</u>	<u>ACCOUNT AMOUNT</u>	<u>ACCOUNT NUMBER</u>	<u>OBJECT DESCRIPTION</u>
R99A0012	OCDE	22,200.00	22,200.00	0174250056 5800	Prof/ConsultingServ&Oper Exp
R99A0013	MAGIC JUMP RENTALS	4,324.50	4,324.50	0109110014 5800	Prof/ConsultingServ&Oper Exp
R99A0014	MAGIC JUMP RENTALS	2,909.70	2,909.70	0109110014 5800	Prof/ConsultingServ&Oper Exp
R99F0132	DANIELS TIRE SERVICE INC.	484.32	484.32	0100000098 5631	Repairs/Vehicles
R99F0133	BUG FLIP	245.00	100.00	0100000121 5570	Pest Control
			90.00	0100000138 5570	Pest Control
			30.00	0100000141 5570	Pest Control
			25.00	0100000142 5570	Pest Control
R99F0134	THE HOME DEPOT PRO INSTITUTION	2,611.90	814.13	0100000089 4300	Materials and Supplies
			282.71	0100000091 4300	Materials and Supplies
			51.16	0100000092 4300	Materials and Supplies
			161.65	0100000093 4300	Materials and Supplies
			632.60	0100000094 4300	Materials and Supplies
			34.59	0100000095 4300	Materials and Supplies
			148.77	0100000096 4300	Materials and Supplies
			137.14	0100000098 4300	Materials and Supplies
			311.94	0100000098 4320	FS Inventory/Supplies
			37.21	0100000108 4300	Materials and Supplies
R99F0135	AMERICAN EXPRESS	297.68	297.68	0100000098 4300	Materials and Supplies
R99F0136	LOWES	162.66	40.07	0100000093 4300	Materials and Supplies
			122.59	0100000098 4300	Materials and Supplies
R99F0137	F.M. THOMAS AIR CONDITIONING	3,011.01	720.00	0100000091 5630	Repairs or Maintenance
			2,291.01	0100000096 5630	Repairs or Maintenance
R99M0248	AMERICAN EXPRESS	210.29	210.29	0100000071 4300	Materials and Supplies
R99M0249	AMERICAN EXPRESS	346.59	346.59	0109110014 4300	Materials and Supplies
R99M0251	AMERICAN EXPRESS	192.00	192.00	0130100032 4300	Materials and Supplies

LOWELL JOINT SD
PURCHASE ORDER DETAIL REPORT
 BOARD OF TRUSTEES MEETING 06/27/2022

FROM 05/01/2022 TO 05/31/2022

<u>PO NUMBER</u>	<u>VENDOR</u>	<u>PO TOTAL</u>	<u>ACCOUNT AMOUNT</u>	<u>ACCOUNT NUMBER</u>	<u>OBJECT DESCRIPTION</u>
R99M0252	AMERICAN EXPRESS	700.84	700.84	0100000317 4300	Materials and Supplies
R99M0253	AMERICAN EXPRESS	178.50	178.50	0105110043 4300	Materials and Supplies
R99R0439	IPRINT TECHNOLOGIES	76.07	76.07	0156400017 4300	Materials and Supplies
R99R0440	BUENA PARK PLAQUE & TROPHY	196.25	196.25	0100000065 4300	Materials and Supplies
R99R0441	BUENA PARK PLAQUE & TROPHY	280.04	280.04	0100000317 4300	Materials and Supplies
R99R0442	BENCHMARK EDUCATION COMPANY	49,593.46	5,600.00 43,993.46	0140350030 5800 0163000003 4130	Prof/Consulting Serv&Oper Exp Textbooks
R99R0443	CALIFORNIA DEPT OF SOCIAL SERV	968.00	968.00	0190200006 5800	Prof/Consulting Serv&Oper Exp
R99R0444	THE ART OF EDUCATION UNIVERSIT	3,183.25	3,183.25	0163000002 5810	Licenses/Technology
R99R0445	SAVVAS LEARNING COMPANY LLC	504,987.15	504,987.15	0163000002 4130	Textbooks
R99R0446	AMERICAN EXPRESS	26,642.64	26,642.64	0163000002 4130	Textbooks
R99R0447	AMERICAN EXPRESS	47.38	47.38	0156400013 4300	Materials and Supplies
R99R0448	J TAYLOR EDUCATION INC	727.65	727.65	0174250054 4300	Materials and Supplies
R99R0449	MONOPRICE INC.	213.70	213.70	0108880039 4300	Materials and Supplies
R99R0450	CENGAGE LEARNING	9,487.73	9,487.73	0163000002 4130	Textbooks
R99R0451	STUDIES WEEKLY	13,180.83	13,180.83	0163000002 4130	Textbooks
R99R0452	WARD'S MEDIA TECH	30,200.76	4,684.52 348.94	0132130005 4400 0132130005 5810	Non Capitalized Equipment Licenses/Technology
			4,684.52	0132130006 4400	Non Capitalized Equipment
			348.94	0132130006 5810	Licenses/Technology
			4,684.52	0132130007 4400	Non Capitalized Equipment
			348.94	0132130007 5810	Licenses/Technology
			4,684.52	0132130008 4400	Non Capitalized Equipment
			348.94	0132130008 5810	Licenses/Technology
			4,684.52	0132130009 4400	Non Capitalized Equipment

LOWELL JOINT SD
PURCHASE ORDER DETAIL REPORT
 BOARD OF TRUSTEES MEETING 06/27/2022

FROM 05/01/2022 TO 05/31/2022

<u>PO NUMBER</u>	<u>VENDOR</u>	<u>PO TOTAL</u>	<u>ACCOUNT AMOUNT</u>	<u>ACCOUNT NUMBER</u>	<u>OBJECT DESCRIPTION</u>
R99R0452	*** CONTINUED ***		348.94	0132130009 5810	Licenses/Technology
			4,684.52	0132130029 4400	Non Capitalized Equipment
			348.94	0132130029 5810	Licenses/Technology
R99R0453	SECRETARY OF STATE	40.00	40.00	0100000009 5810	Licenses/Technology
R99R0454	IMAGINE LEARNING LLC	51,718.50	51,718.50	0174250018 5810	Licenses/Technology
R99R0455	TRINIDAD, GINA	359.69	359.69	0105110043 4300	Materials and Supplies
R99R0456	ENHANCED VISION	3,643.76	3,643.76	0165010001 4300	Materials and Supplies
R99R0457	ASCD	89.00	89.00	0100590006 5810	Licenses/Technology
R99R0458	DELL MARKETING L.P.	3,801.99	182.69	0126000003 4300	Materials and Supplies
			748.76	0126000003 4400	Non Capitalized Equipment
			624.25	0126000004 4300	Materials and Supplies
			2,246.29	0126000004 4400	Non Capitalized Equipment
R99R0459	HOUGHTON MIFFLIN HARCOURT	3,589.12	3,589.12	0163000002 4130	Textbooks
R99R0460	SCHOLASTIC	4,129.79	4,129.79	0109110014 4300	Materials and Supplies
R99R0461	IMPERIAL BAND INSTRUMENTS	56.26	16.26	0105110041 4300	Materials and Supplies
			40.00	0105110041 5630	Repairs or Maintenance
R99R0462	ACTION TROPHY	40.59	40.59	0100000317 4300	Materials and Supplies
R99R0463	BUENA PARK PLAQUE & TROPHY	80.81	80.81	0100000317 4300	Materials and Supplies
R99R0464	JAMES HARDWARE COMPANY	195.85	29.21	0100000100 4300	Materials and Supplies
			25.50	0100000105 4300	Materials and Supplies
			141.14	0100000108 4300	Materials and Supplies
R99R0465	SENTRY SIGNS & PRINTING	121.28	121.28	0100000058 4300	Materials and Supplies
R99R0466	FULLERTON JOINT UNION HS DIST	381.50	381.50	0100510008 4300	Materials and Supplies
R99R0467	HOUGHTON MIFFLIN HARCOURT	14,295.47	14,295.47	0163000002 4130	Textbooks

LOWELL JOINT SD
PURCHASE ORDER DETAIL REPORT
 BOARD OF TRUSTEES MEETING 06/27/2022

FROM 05/01/2022 TO 05/31/2022

<u>PO NUMBER</u>	<u>VENDOR</u>	<u>PO TOTAL</u>	<u>ACCOUNT AMOUNT</u>	<u>ACCOUNT NUMBER</u>	<u>OBJECT DESCRIPTION</u>
R99R0468	PLUMBING WHOLESALE OUTLET	697.05	126.71	0100000089 4300	Materials and Supplies
			570.34	0100000098 4300	Materials and Supplies
R99R0469	IMPERIAL BAND INSTRUMENTS	61.33	61.33	0105110036 4300	Materials and Supplies
R99R0470	IMPERIAL BAND INSTRUMENTS	359.02	231.77	0105110041 4300	Materials and Supplies
			127.25	0105110041 5630	Repairs or Maintenance
R99R0471	ANYWHERE CART	367.14	367.14	0108880039 4300	Materials and Supplies
R99R0472	THE SHERWIN-WILLIAMS CO.	624.07	216.88	0100000094 4300	Materials and Supplies
			171.03	0100000098 4300	Materials and Supplies
			118.08	0100000102 4300	Materials and Supplies
			59.04	0100000103 4300	Materials and Supplies
			59.04	0100000105 4300	Materials and Supplies
R99T0064	VERIZON WIRELESS-LA	983.24	983.24	0156400013 4300	Materials and Supplies
R99T0065	VIG SOLUTIONS	295.00	295.00	0108880020 4300	Materials and Supplies
R99T0066	DATA IMPRESSIONS	16,671.38	2,563.35	0130100044 4300	Materials and Supplies
			14,108.03	0130100044 4400	Non Capitalized Equipment
R99U0010	CHARTER COMMUNICATIONS	25,000.00	25,000.00	0108880045 5910	Communications
R99Y0006	GOTO COMMUNICATIONS INC.	10,000.00	10,000.00	0108880045 5910	Communications
S99R0010	MYSTERY SCIENCE	1,325.00	1,325.00	0100590006 5300	Dues and Memberships
S99R0011	BREAKOUT INC.	99.00	99.00	0100590006 5810	Licenses/Technology
S99T0001	RAPTOR	3,750.00	625.00	0108880026 5810	Licenses/Technology
			625.00	0108880027 5810	Licenses/Technology
			625.00	0108880028 5810	Licenses/Technology
			625.00	0108880029 5810	Licenses/Technology
			625.00	0108880030 5810	Licenses/Technology
			625.00	0108880031 5810	Licenses/Technology
Fund 01 Total:					
					820,435.74

LOWELL JOINT SD
PURCHASE ORDER DETAIL REPORT
BOARD OF TRUSTEES MEETING 06/27/2022

FROM 05/01/2022 TO 05/31/2022

<u>PO</u> <u>NUMBER</u>	<u>VENDOR</u>	<u>PO</u> <u>TOTAL</u>	<u>ACCOUNT</u> <u>AMOUNT</u>	<u>ACCOUNT</u> <u>NUMBER</u>	<u>OBJECT DESCRIPTION</u>
----------------------------	---------------	---------------------------	---------------------------------	---------------------------------	---------------------------

Total Amount of Purchase Orders: 820,435.74

LOWELL JOINT SD
Consolidated Check Register
 from 5/1/2022 to 5/31/2022

Check	Payee ID	Payee Name	Reference	Subs	Check Date	Cancel Date	Type	Status	Check Amount
99	00001395	CANNINGS HARDWARE LA HABRA	491955	OH	05/04/2022		MW	IS	67.14
99	00001396	T-MOBILE	0321042022	OH	05/04/2022		MW	IS	869.40
99	00001397	COLLEEN PATTERSON	LOWELL0401022	OH	05/05/2022		MW	IS	437.50
99	00001398	DIANA GONZALEZ	4/26-4/29/22 MIL	OH	05/05/2022		MW	IS	102.02
99	00001399	iPRINT TECHNOLOGIES	6020045	OH	05/05/2022		MW	IS	70.56
99	00001400	iPRINT TECHNOLOGIES	885495	OH	05/05/2022		MW	IS	132.30
99	00001401	JONES SCHOOL SUPPLY COMPANY	1874001	OH	05/05/2022		MW	IS	563.36
99	00001402	KALEO IGARTA	CUE 3/17-3/18	OH	05/05/2022		MW	IS	107.52
99	00001403	LEES, DEBRA	029	OH	05/05/2022		MW	IS	1,400.00
99	00001404	LESLIE MANGOLD	050222	OH	05/05/2022		MW	IS	37.60
99	00001405	MYSTERY SCIENCE	168397	OH	05/05/2022		MW	IS	1,324.94
99	00001406	NCS PEARSON INC.	17961380	OH	05/05/2022		MW	IS	208.73
99	00001407	OCDE	94R13770	OH	05/05/2022		MW	IS	22,200.00
99	00001408	PATTY JACOBSEN	PURCH EXP	OH	05/05/2022		MW	IS	704.16
99	00001409	SUSAN TOLMOSOFF	050222	OH	05/05/2022		MW	IS	37.70
99	00001410	WARE DISPOSAL	956815	OH	05/05/2022		MW	IS	1,637.94
99	00001411	ADMINISTRATIVE SERV. CO-OP	13733	OH	05/05/2022		MW	IS	4,650.00
99	00001412	DIVISION OF THE STATE ARCHITECT	03-13087	OH	05/05/2022		MW	IS	27,290.52
99	00001413	ABES PLUMBING INC.	21114	OH	05/06/2022		MW	IS	575.00
99	00001414	BISHOP CO.	INV-717240	OH	05/06/2022		MW	IS	90.37
99	00001415	BLICK ART MATERIALS	8455143	OH	05/06/2022		MW	IS	165.36
99	00001416	BUENA PARK PLAQUE & TROPHY	18573	OH	05/06/2022		MW	IS	465.49
99	00001417	CRISTIAN BOGDAN	MILEAGE-APR202	OH	05/06/2022		MW	IS	31.76
99	00001418	DASH MEDICAL GLOVES	INV1260879	OH	05/06/2022		MW	IS	425.86
99	00001419	DATA IMPRESSIONS	19120-IN	OH	05/06/2022		MW	IS	1,217.70
99	00001420	DELTA DENTAL OF CALIFORNIA	BE004950328	OH	05/06/2022		MW	IS	1,951.21
99	00001421	iPRINT TECHNOLOGIES	886949	OH	05/06/2022		MW	IS	650.48
99	00001422	iPRINT TECHNOLOGIES	888498	OH	05/06/2022		MW	IS	76.09
99	00001423	iPRINT TECHNOLOGIES	886949	OH	05/06/2022		MW	IS	70.66
99	00001424	JIM COOMBS	PD-SUPT 4/26/22	OH	05/06/2022		MW	IS	198.82
99	00001425	JOHN ZAPPULLA	MILEAGE APR	OH	05/06/2022		MW	IS	65.76
99	00001426	LEADER SERVICES	CDS5854	OH	05/06/2022		MW	IS	884.42
99	00001427	MARY JO EVANOFF	PD-TABLE	OH	05/06/2022		MW	IS	472.10
99	00001428	MJ'S ART STAMPS	2331	OH	05/06/2022		MW	IS	55.90

LOWELL JOINT SD
Consolidated Check Register
 from 5/1/2022 to 5/31/2022

Check	Payee ID	Payee Name	Reference	Subs	Check Date	Cancel Date	Type	Status	Check Amount
99 00001429	B9903229	HAULAWAY STORAGE CONTAINERS	2054906	OH	05/06/2022		MW	IS	539.96
99 00001430	V9900085	HOWARD TECHNOLOGY SOLUTION	22-00463335 & 34	OH	05/06/2022		MW	IS	2,160.55
99 00001431	F9900014	BUG FLIP	477634	OH	05/09/2022		MW	IS	245.00
99 00001432	V9903399	CALIFORNIA DEPT OF SOCIAL SERV	LICENSE FEE	OH	05/09/2022		MW	IS	968.00
99 00001433	U9900003	MCI A VERIZON COMPANY	409076224	OH	05/09/2022		MW	IS	4.53
99 00001434	U9900004	SOUTHERN CALIFORNIA EDISON	0401043022	OH	05/09/2022		MW	IS	7,508.98
99 00001435	U9900005	SOUTHERN CALIFORNIA GAS CO	0324042222	OH	05/09/2022		MW	IS	203.82
99 00001436	U9900006	SUBURBAN WATER SYSTEMS	181003191166	OH	05/09/2022		MW	IS	9,649.62
99 00001437	F9900014	BUG FLIP	APRIL2022	OH	05/09/2022		MW	IS	180.00
99 00001438	F9900045	LADY BUGS ENVIRONMENTAL TERMIT	146511	OH	05/09/2022		MW	IS	55.00
99 00001439	N9900009	P & R PAPER SUPPLY COMPANY	APRIL2022	OH	05/09/2022		MW	IS	3,434.99
99 00001440	N9900013	SOUTHERN CALIFORNIA PIZZA	APRIL2022	OH	05/09/2022		MW	IS	15,688.00
99 00001441	V9903348	BROTHERS AUTOMOTIVE INC	508	OH	05/10/2022		MW	IS	1,127.29
99 00001442	F9900023	DANIELS TIRE SERVICE INC.	140103326	OH	05/10/2022		MW	IS	484.32
99 00001443	F9900059	THE HOME DEPOT PRO INSTITUTION	681653804	OH	05/10/2022		MW	IS	2,611.87
99 00001444	B9900010	ERICKSON-HALL CONSTRUCTION	PAY APP# 12-APR	OH	05/10/2022		MW	IS	475,670.70
99 00001445	B9900011	GHATAODE BANNON ARCHITECTS	4723	OH	05/10/2022		MW	IS	28,672.88
99 00001446	B9900013	HAUFFE COMPANY	432	OH	05/10/2022		MW	IS	14,112.00
99 00001447	V9900201	BSN SPORTS LLC dba US GAMES	915517632	OH	05/11/2022		MW	IS	961.38
99 00001448	V9903371	CHRIS BECERRA CONSULTING SERVI	FEB-APR 2022 SVCOH	OH	05/11/2022		MW	IS	6,000.00
99 00001449	V9903403	DANA MORRISON	EXP REIMB-CUE	OH	05/11/2022		MW	IS	100.52
99 00001450	V9903402	HEAR NOW	22080	OH	05/11/2022		MW	IS	775.00
99 00001451	E9900115	KRISTA VAN HOOGMOED	050622	OH	05/11/2022		MW	IS	133.22
99 00001452	E9900138	MARIKATE ELMQUIST	REIMB-DOJ FEES	OH	05/11/2022		MW	IS	102.00
99 00001453	V9903326	MELARAGNO, ALBERT	040222-PROF SVCSOH	OH	05/11/2022		MW	IS	175.00
99 00001454	E9900148	MICHELLE MCNEFF	CUE CONF-3/18	OH	05/11/2022		MW	IS	89.92
99 00001455	F9900050	NEW MANAGEMENT INC	6731	OH	05/11/2022		MW	IS	69.46
99 00001456	V9900131	NIGRO & NIGRO	15947	OH	05/11/2022		MW	IS	6,210.00
99 00001457	V9903367	OAK HALL INDUSTRIES L.P.	3696149	OH	05/11/2022		MW	IS	5,156.37
99 00001458	V9900151	RAPTOR	INV31683	OH	05/11/2022		MW	IS	545.74
99 00001459	E9900172	RHONDA OVERYBY	031122 REIMB	OH	05/11/2022		MW	IS	123.20
99 00001460	S9900004	RIFTON EQUIPMENT	S341K-1	OH	05/11/2022		MW	IS	28.65
99 00001461	V9900159	RIVERSIDE INSIGHTS	INV111226	OH	05/11/2022		MW	IS	5,020.00
99 00001462	V9900163	ROCHESTER 100 INC.	INV012816	OH	05/11/2022		MW	IS	290.00

LOWELL JOINT SD
Consolidated Check Register
 from 5/1/2022 to 5/31/2022

Check	Payee ID	Payee Name	Reference	Subs	Check Date	Cancel Date	Type	Status	Check Amount
99	00001463	RUSSELL, EILEEN	MARCH 2022	OH	05/11/2022		MW	IS	375.00
99	00001464	SANCHEZ, EFRAIN	000254	OH	05/11/2022		MW	IS	250.00
99	00001465	SCHOOL SPECIALTY	308103943081	OH	05/11/2022		MW	IS	1,114.04
99	00001466	SENTRY SIGNS & PRINTING	1890	OH	05/11/2022		MW	IS	595.35
99	00001467	STUDIES WEEKLY	431957	OH	05/11/2022		MW	IS	107.82
99	00001468	SUPER DUPER PUBLICATIONS	2721681A	OH	05/11/2022		MW	IS	502.74
99	00001469	TECHNICOLOR PRINTING	6700	OH	05/11/2022		MW	IS	1,060.39
99	00001470	TREASURE BAY, INC.	TB-13882	OH	05/11/2022		MW	IS	3,439.38
99	00001471	WALTERS WHOLESALE ELECTRIC	S120157851.001	OH	05/11/2022		MW	IS	2,198.74
99	00001472	YUMI YAMAMOTO	REIMB-3/29/22	OH	05/11/2022		MW	IS	12.44
99	00001473	SCHOOL SERVICES OF CALIFORNIA	W120019-IN	OH	05/11/2022		MW	IS	260.00
99	00001474	HANCOCK PARK & DELONG INC	5812	OH	05/11/2022		MW	IS	3,500.00
99	00001475	VOID.CONTIVoid - Continued Stub	CONTINUE	OH	05/12/2022		VM	VD	0.00
99	00001476	AMERICAN EXPRESS	TARGET-02314846	OH	05/12/2022		MW	IS	27,856.71
99	00001477	ANGIE HUTCHERSON	MAR/APR 2022	OH	05/12/2022		MW	IS	370.86
99	00001478	DIANA GONZALEZ	MILEAGE-5/3/22	OH	05/12/2022		MW	IS	25.51
99	00001479	JEFF SCHREIHART	PURCH REIMB	OH	05/12/2022		MW	IS	79.76
99	00001480	RIFTON EQUIPMENT	S344K-1	OH	05/12/2022		MW	IS	3,530.77
99	00001481	RUSSELL, EILEEN	APRIL 2022	OH	05/12/2022		MW	IS	300.00
99	00001482	SCHOOL LIFE	INV-200055736	OH	05/12/2022		MW	IS	331.23
99	00001483	SCHOOL SERVICES OF CALIFORNIA	0133034-IN	OH	05/12/2022		MW	IS	340.00
99	00001484	SCHOOL SPECIALTY	308103955360	OH	05/12/2022		MW	IS	1,184.80
99	00001485	SENTRY SIGNS & PRINTING	3520/3268	OH	05/12/2022		MW	IS	509.68
99	00001486	SPARKLETT'S	15734879050822	OH	05/12/2022		MW	IS	174.77
99	00001487	THERAPY SHOPPE	382402	OH	05/12/2022		MW	IS	22.48
99	00001488	THINKING MAPS	INV0062781	OH	05/12/2022		MW	IS	11,000.00
99	00001489	VIG SOLUTIONS	10924	OH	05/12/2022		MW	IS	4,605.28
99	00001490	Continental Sales	APRIL2022	OH	05/12/2022		MW	IS	10,282.94
99	00001491	DRIFTWOOD DAIRY	APRIL2022	OH	05/12/2022		MW	IS	13,366.26
99	00001492	GOLD STAR FOODS	APRIL2022	OH	05/12/2022		MW	IS	20,456.30
99	00001493	RMA GROUP	79084	OH	05/12/2022		MW	IS	11,744.00
99	00001494	SILVER CREEK INDUSTRIES	PAY APP#5	OH	05/12/2022		MW	IS	171,188.62
99	00001495	BIANCA GALANG	MAR22 CUE CONF	OH	05/13/2022		MW	IS	197.12
99	00001496	BREE KOSAREFF	21-22 CLSRM	OH	05/13/2022		MW	IS	243.89

LOWELL JOINT SD
Consolidated Check Register
 from 5/1/2022 to 5/31/2022

Check	Payee ID	Payee Name	Reference	Subs	Check Date	Cancel Date	Type	Status	Check Amount
99 00001497	E9900030	BRENDA RODRIGUEZ	21-22 CLSRM	OH	05/13/2022		MW	IS	301.56
99 00001498	E9900059	DIANA JACOBS	MAR 2022 CUE	OH	05/13/2022		MW	IS	272.97
99 00001499	F9900031	F.M. THOMAS AIR CONDITIONING	43743	OH	05/13/2022		MW	IS	2,502.00
99 00001500	U9900002	FRONTIER	0502060122	OH	05/13/2022		MW	IS	74.87
99 00001501	V9903376	GoTo Communications Inc.	IN7101131338	OH	05/13/2022		MW	IS	4,425.03
99 00001502	E9900073	HEATHER PFAFF	21-22 CLSRM	OH	05/13/2022		MW	IS	151.33
99 00001503	V9903410	JAUREGUI, KRISTEN JOY	21-22 CLSRM	OH	05/13/2022		MW	IS	242.94
99 00001504	E9900098	KARI DANIEL	MAR2022 CUE	OH	05/13/2022		MW	IS	170.47
99 00001505	V9903413	KATLYN CHENG	21-22 CLSRM	OH	05/13/2022		MW	IS	153.03
99 00001506	E9900122	LECIA GUNSALUS	21-22 CLSRM	OH	05/13/2022		MW	IS	189.58
99 00001507	E9900138	MARIKATE ELMQUIST	REIMB-FAM	OH	05/13/2022		MW	IS	283.71
99 00001508	V9903412	NATALY BENTON	21-22 CLSRM SPPL	OH	05/13/2022		MW	IS	204.30
99 00001509	E9900157	NICOLE ULLOA	21-22 CLSRM	OH	05/13/2022		MW	IS	214.84
99 00001510	E9900174	ROBERT LAUPRECHT	21-22 CLSRM	OH	05/13/2022		MW	IS	52.69
99 00001511	E9900184	SHAINA MONTIEL	21-22 CLSRM	OH	05/13/2022		MW	IS	46.20
99 00001512	U9900004	SOUTHERN CALIFORNIA EDISON	0406050522	OH	05/13/2022		MW	IS	8,652.31
99 00001513	U9900005	SOUTHERN CALIFORNIA GAS CO	0331042922	OH	05/13/2022		MW	IS	304.75
99 00001514	U9900006	SUBURBAN WATER SYSTEMS	180071326904	OH	05/13/2022		MW	IS	4,205.09
99 00001515	E9900217	YOVANNA RIVERA	21-22CLSRM SUPP	OH	05/13/2022		MW	IS	31.48
99 00001516	E9900218	YUMI YAMAMOTO	MAR22LIB REIMB	OH	05/13/2022		MW	IS	78.86
99 00001517	V9903406	SECRETARY OF STATE	RENEWAL2245896	OH	05/16/2022		MW	IS	40.00
99 00001518	U9900008	T-MOBILE	0404050322	OH	05/17/2022		MW	IS	750.00
99 00001519	V9903373	WESTERN TURF EQUIPMENT	4594	OH	05/17/2022		MW	IS	13,380.00
99 00001520	V9903400	CHARTER COMMUNICATIONS	12181040922	OH	05/19/2022		MW	IS	8,991.59
99 00001521	S9990002	GALLAGHER PEDIATRIC THERAP	9785	OH	05/19/2022		MW	IS	1,828.95
99 00001522	V9900095	JONES SCHOOL SUPPLY COMPANY	1874499	OH	05/19/2022		MW	IS	170.61
99 00001523	V9903295	MAX-ABILITY	103430	OH	05/19/2022		MW	IS	902.95
99 00001524	E9900003	ADRIANA PONCE	EXP	OH	05/20/2022		MW	IS	87.58
99 00001525	V9900201	BSN SPORTS LLC dba US GAMES	916890247	OH	05/20/2022		MW	IS	692.00
99 00001526	V9903264	DIANA GONZALEZ	MILEAGEREIMB5/OH	OH	05/20/2022		MW	IS	25.50
99 00001527	E9900073	HEATHER PFAFF	042822PKG REIMB	OH	05/20/2022		MW	IS	15.00
99 00001528	F9900040	JAMES HARDWARE COMPANY	2204-008582	OH	05/20/2022		MW	IS	195.85
99 00001529	V9903416	JOHNSON, BRIAN	LJYT-CNTRT	OH	05/20/2022		MW	IS	3,500.00
99 00001530	V9903417	JOHNSON, CALLIE	LJYT-MACY	OH	05/20/2022		MW	IS	2,000.00

LOWELL JOINT SD
Consolidated Check Register
 from 5/1/2022 to 5/31/2022

Check	Payee ID	Payee Name	Reference	Subs	Check Date	Cancel Date	Type	Status	Check Amount
99 00001531	V9903279	LOPEZ, ALEJANDRO	APRIL2022 SVC	OH	05/20/2022		MW	IS	357.15
99 00001532	V9900116	MAGIC JUMP RENTALS	338705	OH	05/20/2022		MW	IS	4,324.50
99 00001533	V9900116	MAGIC JUMP RENTALS	338491	OH	05/20/2022		MW	IS	2,909.70
99 00001534	V9903415	NEAVEZ, MARY MADELINE	00000001	OH	05/20/2022		MW	IS	1,500.00
99 00001535	V9900154	READYREFRESH BY NESTLE	02E0032621385	OH	05/20/2022		MW	IS	73.85
99 00001536	V9903343	ROCKY MOUNTAIN SHIRT CO	11269	OH	05/20/2022		MW	IS	804.00
99 00001537	V9903330	SCHOLASTIC	W5087151BF	OH	05/20/2022		MW	IS	4,129.79
99 00001538	V9900172	SCHOOL SERVICES OF CALIFORNIA	0133365-IN	OH	05/20/2022		MW	IS	340.00
99 00001539	V9900179	SOUTHWEST SCHOOL SUPPLY	R99X0002MG-MA	OH	05/20/2022		MW	IS	7,503.84
99 00001540	V9903397	THE ART OF EDUCATION UNIVERSIT	319856	OH	05/20/2022		MW	IS	3,183.25
99 00001541	I9900011	TRINIDAD, GINA	041322-R99R0455	OH	05/20/2022		MW	IS	357.24
99 00001542	U9900010	WARE DISPOSAL	977921	OH	05/20/2022		MW	IS	2,825.47
99 00001543	V9900160	RMA GROUP	79328	OH	05/20/2022		MW	IS	15,125.50
99 00001544	V9903404	IMAGINE LEARNING LLC	858964	OH	05/23/2022		MW	IS	51,718.50
99 00001545	V9900131	NIGRO & NIGRO	16381	OH	05/23/2022		MW	IS	6,210.00
99 00001546	I9900002	BYRON FERGUSON DBA ALL AMERICA	1003-RS SPORTS	OH	05/24/2022		MW	IS	1,100.00
99 00001547	F9900047	LOWES	926912	OH	05/24/2022		MW	IS	162.66
99 00001548	V9903419	NANCY KEMP	INV. 1	OH	05/24/2022		MW	IS	250.00
99 00001549	V9900175	SENTRY SIGNS & PRINTING	3716	OH	05/24/2022		MW	IS	121.28
99 00001550	V9900007	ACTION TROPHY	91575	OH	05/25/2022		MW	IS	40.59
99 00001551	E9900009	AMANDA MALM	CUE 3/17-3/19	OH	05/25/2022		MW	IS	81.55
99 00001552	E9903276	ANDREW RUDDOCK	SCIENCEPROJECT	OH	05/25/2022		MW	IS	48.68
99 00001553	V9900028	BUENA PARK PLAQUE & TROPHY	18858	OH	05/25/2022		MW	IS	80.81
99 00001554	V9903362	DELL MARKETING L.P.	10577874836	OH	05/25/2022		MW	IS	1,416.04
99 00001555	F9900031	F.M. THOMAS AIR CONDITIONING	43784	OH	05/25/2022		MW	IS	3,011.01
99 00001556	U9900002	FRONTIER	MAY22	OH	05/25/2022		MW	IS	1,018.09
99 00001557	V9900076	FULLERTON JOINT UNION HS DIST	70RJ0140	OH	05/25/2022		MW	IS	381.50
99 00001558	V9903376	GoTo Communications Inc.	IN7101087749	OH	05/25/2022		MW	IS	386.69
99 00001559	V9903282	GOVCONNECTION INC.	72605679	OH	05/25/2022		MW	IS	2,612.92
99 00001560	E9900221	JENNIFER JACKSON	STAFFAPPRECTN	OH	05/25/2022		MW	IS	80.57
99 00001561	E9900165	REBECCA CHAMPION	CUE 3/17-3/19	OH	05/25/2022		MW	IS	164.15
99 00001562	E9900172	RHONDA OVERYB	CUE 3/17-3/19	OH	05/25/2022		MW	IS	500.76
99 00001563	U9900004	SOUTHERN CALIFORNIA EDISON	0413051222	OH	05/25/2022		MW	IS	13,603.22
99 00001564	U9900005	SOUTHERN CALIFORNIA GAS CO	0415051622	OH	05/25/2022		MW	IS	848.57

LOWELL JOINT SD
Consolidated Check Register
 from 5/1/2022 to 5/31/2022

Check	Payee ID	Payee Name	Reference	Subs	Check Date	Cancel Date	Type	Status	Check Amount
99	00001565	WHITNEY TAKACS	STAFF-TOP100	OH	05/25/2022		MW	IS	222.42
99	00001566	ARAIZA, ISABEL	APRIL/MAY 2022	OH	05/26/2022		MW	IS	500.00
99	00001567	BRENT ALLSMAN	JUNE	OH	05/26/2022		MW	IS	557.02
99	00001568	CAROLYN KANE	JUNE	OH	05/26/2022		MW	IS	1,290.56
99	00001569	CLAUDIA SCHALCHLIN	JUNE	OH	05/26/2022		MW	IS	570.78
99	00001570	DATA IMPRESSIONS	19346-IN	OH	05/26/2022		MW	IS	33,119.75
99	00001571	DIANA GONZALEZ	W/E 5/20/22MILEG	OH	05/26/2022		MW	IS	127.53
99	00001572	EDDY VEGA	JUNE	OH	05/26/2022		MW	IS	557.02
99	00001573	EMILY WAKEFIELD	JUNE	OH	05/26/2022		MW	IS	570.78
99	00001574	GAYLE ROGERS	JUNE	OH	05/26/2022		MW	IS	232.94
99	00001575	JULIE ROTH	JUNE	OH	05/26/2022		MW	IS	570.78
99	00001576	MARGARET DUMADAG	JUNE	OH	05/26/2022		MW	IS	557.02
99	00001577	NANCY WHITE	JUNE	OH	05/26/2022		MW	IS	1,290.56
99	00001578	PENNY MAYERCHECK	JUNE	OH	05/26/2022		MW	IS	1,290.56
99	00001579	PLUMBING WHOLESAL OUTLET	100582186.001	OH	05/26/2022		MW	IS	697.05
99	00001580	RONALD RANDOLPH	JUNE	OH	05/26/2022		MW	IS	614.88
99	00001581	SHELLEY MARKER	JUNE	OH	05/26/2022		MW	IS	570.78
99	00001582	SOUTHWEST SCHOOL SUPPLY	SUPT-R99X0020	OH	05/26/2022		MW	IS	15,573.03
99	00001583	SOUTHWEST SCHOOL SUPPLY	PINV0922320,0953	OH	05/26/2022		MW	IS	474.77
99	00001584	BRUCE PATTILLO	JUNE	OH	05/26/2022		MW	IS	557.02
99	00001585	ALLIANCE OF SCHOOLS FOR COOPER	050122VL	OH	05/31/2022		MW	IS	1,277.12
99	00001586	ASCD	14216216	OH	05/31/2022		MW	IS	89.00
99	00001587	IMPERIAL BAND INSTRUMENTS	68504	OH	05/31/2022		MW	IS	56.26
99	00001588	IMPERIAL BAND INSTRUMENTS	68576	OH	05/31/2022		MW	IS	61.32
99	00001589	INTERQUEST DETECTION	145-0422A	OH	05/31/2022		MW	IS	215.00
99	00001590	LA HABRA COLLABORATIVE	10025	OH	05/31/2022		MW	IS	1,000.00
99	00001591	LAKESHORE LEARNING MATERIALS	827001042222	OH	05/31/2022		MW	IS	521.66
99	00001592	MONOPRICE INC.	22535134	OH	05/31/2022		MW	IS	8.38
99	00001593	MONOPRICE INC.	22615183	OH	05/31/2022		MW	IS	215.12
99	00001594	OCDE	94RI4424	OH	05/31/2022		MW	IS	53.60

Issued: 1,195,415.85

LOWELL JOINT SD
Consolidated Check Register
 from 5/1/2022 to 5/31/2022

Check	Payee ID	Payee Name	Reference	Subs Check Date	Cancel Date	Type	Status	Check Amount
99 Bank Total:								1,195,415.85

Grand Total: 1,195,415.85

LOWELL JOINT SCHOOL DISTRICT
EMPLOYER-EMPLOYEE RELATIONS/PERSONNEL REPORT 2021/2022 #12

June 27, 2022

I. CERTIFICATED EMPLOYEES

A. RESIGNATION

NAME	EFFECTIVE DATE	END DATE	SITE	COMMENT
Solis, Ashley	07/07/2022		JO	Resignation. Elementary Teacher.

B. SUBSTITUTE CHANGE OF PAY

NAME	EFFECTIVE DATE	END DATE	SITE	COMMENT
deBruijn, Lisa	06/09/2022	06/30/2022	DO	Substitute Teacher Summer School to be paid at a daily rate of \$200

C. MANAGEMENT 2022-2023**

NAME	EFFECTIVE DATE	EFFECTIVE DATE	CLASS/COL/STEP	SITE	COMMENTS
Coombs, Jim	07/01/2022	06/30/2025		DO	Contract 2022-2025. Longevity \$4000.00
Reynolds, Andrea	07/01/2022		Range 8	DO	Contract. Longevity \$6000.00
McDonald, Sheri	07/01/2022		Column 7	DO	Contract. Longevity \$4,000.00
Bennett, David	07/01/2022		Range 7	DO	Contract.

D. CERTIFICATED SALARIES 2022-2023**

NAME	EFFECTIVE DATE	EFFECTIVE DATE	CLASS/COL/STEP	SITE	COMMENTS
Morrison, Dana	08/15/2022	06/02/2023	C 5/S1	EP	Correction EER #11 2021-2022
Liles, Amy	08/15/2022	06/02/2023	C5/S23	JO	80% Tenured 20% Leave of Absence – Tenured at 100% Correction EER #11 2021-2022
Cazares, Ariana	08/15/2022	06/02/2023	C5/S9	RS	Correction EER #11 2021-2022
Gonzalez, Trisha	08/03/2022	06/14/2023	C3/S8	DO	Nurse Salary Schedule

E. 2022-2023 CONTRACTS**

NAME	EFFECTIVE DATE	CLASS/COL/STEP	SITE	COMMENTS
Montemayor, Kathleen	08/15/2022	C4/S3	JO	5 th grade teacher. Temporary Contract. Correction EER #11 2020-2021
Petersen, Kaycee	08/15/2022	C5/S1	JO	4 th grade 50% teacher Temporary Contract.

F. EXTRA DUTY / STIPENDS 2022-2023

NAME	EFFECTIVE DATE	END DATE	SITE	COMMENT
Coleman, Rachel	07/11/2022	07/12/2022	EP	To be paid for training for EL Boot camp. Not to exceed \$35 an hour at El Portal. To be paid from ELO-G Funds
Coleman, Rachel	07/25/2022	08/05/2022	EP	To be paid for EL Boot camp teacher. Monday through Friday 7:30 – 12:30 at \$35 an hour at El Portal. To be paid from ELO-G Funds

Palmer, Margaret	08/15/2022	06/02/2023	OL	To be paid \$300.00 per month, not to exceed \$3000.00 for serving as an Intervention Coordinator. To be paid from Supplemental Funds.
Brander, Holly	07/01/2022	06/30/2023	DO	To be paid a total of \$3,750.00 for an additional 10 workdays. To be paid from ELO- G Funds
Champion, Rebecca	07/01/2022	06/30/2023	DO	To be paid a total of \$7,500.00 for an additional 20 workdays. To be paid from ELO-G Funds
Castillo, Barbara	07/01/2022	06/30/2023	DO	To be paid a total of \$7,500.00 for an additional 20 workdays. To be paid from ELO-G Funds
Campbell, Kaitlyn	08/15/2022	06/03/2023	EP	To be paid \$300.00 per month, not to exceed \$3,000.00 for serving as an Intervention Coordinator. To be paid from EP Site Title 1
Morrison, Dana	08/15/2022	06/03/2023	EP	To be paid \$150.00 per month, not to exceed \$1,500.00 for serving as an Intervention Coordinator. To be paid from Supplemental Funds
McNeff, Michelle	11/01/2022	06/03/2023	EP	To be paid \$150 per month, not to exceed \$1500.00 \$150.00 for serving as an Intervention Coordinator (November - May) To be paid from Supplemental Funds

* It is further recommended that these individuals be approved for substitute teaching at the rate of \$200.00 per day and/or \$35.00 an hour rate (not to exceed six hours) as applicable and to include: Professional Development, Saturday School, Site Support Duties and Intervention

**It is further recommended that the individuals listed in Certificated Salaries for 2022-2023 is approved to instruct in the Intervention Programs. The rate of pay is \$35.00/hour and will be paid from Title I or LCFF Supplemental Grant Funds.

**It is further recommended that individuals listed in Certificated Salaries for 2022-2023 serve as home school teachers, if needed, for the 2022-2023 school year at a rate of \$35.00/hour, not to exceed five hours per week, per student. Mileage will be paid at the IRS Standard Mileage Rate for the 2022-2023 school year.

Allsman, Brent	Charman, Lauren	Jones, Lilian	Moreno, Christina	Silva, Kathie
Christine Ontiveros	Childress, Whittany	Kjer, Kevin	Nordell, Karen	Stephenson, Rebecca
Gonzalez, Ilene	Cifuentes, Carlos	Kushi, Yumi	Opfer, Debbie	Stoermer, Bryce
Hernandez, Rebecca	Conforti, Tammy	Larsen, Danica	Opfer, Debbie	Tyner, Bonnie
Alvarez, Sidney	Dankert, Marian	Lawton, Amber	Petersen, Kaycee	Van Eck, Christina
Anderson, Tammy	Davis, Eloisa	Lees, Debra	Peterson, Monica	Vega, Sandy
Beiderwell, Elizabeth	Davis, Summer	Lower, Corissa	Pilkington, Felicia	Wallace, Gregory
Belk-Dumont, Juliette	DeBruijn, Lisa	Marin, Claudia	Praefke, Amy	Warner, Ellie
Bishop, Davette C	Fuller, Duke	McCoy, Stacey	Prosser, Brynn	Windust, Julie
Bradshaw, Casey	Garcia, Patricia	McCullough, Jennifer	Quinlan, Dyana	Wu, Crystal
Brooks, Edward	Gonzalez, Leslie	Melgar, Tania	Rouse, Christine	Zarate, Laurie
Buckner, Iris	Green, Georgia	Mgrdichian, Jennifer	San Martin, Jerry	Zavala, Kimberly
Butler, Nicole	Haworth, Acacia	Milton, Lisa	Sauceda, Antoinette	Zazueta, Jacqueline
Campbell, Kevin	Jacobsen, Brennan	Milward, Cathe	Schulze, Jennifer	Montemayor, Kathleen
Carr, Candice	Jarvis, Melanie	Morales, Ivan	Scott, Susan	

G. SUBSTITUTE CHANGE OF PAY

deBruijn, Lisa	07/01/2022	07/07/2022	DO	Substitute Teacher Summer School to be paid at a daily rate of \$200
deBruijn, Lisa	07/11/2022	07/12/2022	DO	To be paid for training for EL Boot camp. Not to exceed \$35 an hour. To be paid from ELO-G Funds
deBruijn, Lisa	07/25/2022	08/05/2022	DO	To be paid for EL Boot camp substitute teacher. Monday through Friday 7:30 – 12:30 at \$35 an hour at El Portal. To be paid from ELO-G Funds
Montemayor, Kathleen	07/11/2022	07/12/2022	DO	To be paid for training for EL Boot camp. Not to exceed \$35 an hour. To be paid from ELO-G Funds

Montemayor, Kathleen	07/25/2022	08/05/2022		To be paid for EL Boot camp Substitute Teacher. Monday through Friday 7:30 – 12:30 at \$35 an hour at El Portal. To be paid from ELO-G Funds
Gonzalez, Leslie	07/11/2022	07/12/2022	DO	To be paid for training for EL Boot camp. Not to exceed \$35 an hour. To be paid from ELO-G Funds
Gonzalez, Leslie	07/25/2022	08/05/2022	DO	To be paid for EL Boot camp teacher. Monday through Friday 7:30 – 12:30 at \$35 an hour at El Portal. To be paid from ELO-G Funds
Charman, Lauren	07/11/2022	07/12/2022	DO	To be paid for training for EL Boot camp. Not to exceed \$35 an hour at El Portal. To be paid from ELO-G Funds
Charman, Lauren	07/25/2022	08/05/2022	DO	To be paid for EL Boot camp teacher. Monday through Friday 7:30 – 12:30 at \$35 an hour at El Portal. To be paid from ELO-G Funds

* It is further recommended that these individuals be approved for substitute teaching at the rate of \$200.00 per day and/or \$35.00 an hour rate (not to exceed six hours) as applicable and to include: Professional Development, Saturday School, Site Support Duties and Intervention

**It is further recommended that the individuals listed in Certificated Salaries for 2022-2023 is approved to instruct in the Intervention Programs. The rate of pay is \$35.00/hour and will be paid from Title I or LCFF Supplemental Grant Funds.

**It is further recommended that individuals listed in Certificated Salaries for 2022-2023 serve as home school teachers, if needed, for the 2022-2023 school year at a rate of \$35.00/hour, not to exceed five hours per week, per student. Mileage will be paid at the IRS Standard Mileage Rate for the 2022-2023 school year.

Employment of substitutes effective 08/15/2022 for the 2022-2023 school year @ 200 per day and \$100.00 per half day rate and \$35.00 per hour* (not to exceed six hours) as applicable and to include: professional development, Saturday school, and site support duties, and \$250.00 long term sub rate.

II. CLASSIFIED EMPLOYEES June 27, 2022

A. MONTHLY – GENERAL FUND

B. HOURLY – GENERAL FUND

<u>NAME/ EMPLOYEE ID#</u>	<u>EFFECTIVE DATE</u>	<u>END DATE</u>	<u>RANGE/ STEP</u>	<u>SITE</u>	<u>COMMENTS</u>
Anderson, Adriana	08/15/2022		R7/S5	EP	New Hire-Cafeteria Worker
Bargas, Kerri	06/16/2022		R7/S8	Nut Serv.	Resignation-Cafeteria Worker
Bolendo, Sharlecia "Lisa"	07/05/2022		R23/S4	DO	New Hire-Fiscal Clerk-Special Programs
Caciappo, Sherrie	06/08/2022		R7/S6	Nut Serv.	Resignation-Cafeteria Worker
Caciappo, Sherrie	08/15/2022		R14/S1	DO	Substitute-Instructional Aide
Cardenas, Lauren	08/15/2022		R7/S5	MG	New Hire-Cafeteria Worker
Castro, Claudia	06/09/2022	06/30/2022	R14/S1	DO	IA/Substitute/Summer
Castro, Claudia	07/01/2022	08/15/2022	R14/S1	DO	IA/Substitute/Summer
Castro, Claudia	06/09/2022	06/30/2022	R16/S1	DO	Clerk//Substitute/Summer
Castro, Claudia	07/01/2022	08/15/2022	R15/S1	DO	Health Tech/Substitute/Summer
Costello, Jennifer	07/01/2020		R7/S6	MG	Step Increase CW-per AR
Costello, Jennifer	07/01/2021		R7/S7	MG	Step Increase CW-per AR
Costello, Jennifer	07/01/2022		R7/S8	MG	Step Increase CW-per AR
Costello, Jennifer	08/15/2022		R14/S5	MG	New Hire-Promotion to Sat Cafeteria Worker
Estrada, Liz	06/09/2022	06/30/2022	R14/S6	DO	IA/Substitute/Summer
Estrada, Liz	07/01/2022	08/15/2022	R14/S6	DO	IA/Substitute/Summer
Garcia, Hector	07/27/2022	07/29/2022	R20/S6	M&O	FMLA-Groundskeeper

Hernandez, Darlene	06/6/2022	06/30/2022	R23/S8	DO	Fiscal Clerk Decrease in hours-FT 40 hours to PT 32 hours
Hernandez, Darlene	07/1/2022		R23/S8	DO	Fiscal Clerk Decrease in hours-FT 40 hours to PT 32 hours
Hutcherson, Angie	08/08/2022	10/24/2022	R15/S8	MG	Leave of Absence-Instructional Aide
Lopez, Donna	07/01/2022	08/05/2022	R15/S8	EP	IA/Summer Assignment
Ramos, Adriana	06/01/2022			DO	Remove-sub who never started
Reyatt, Manjit	08/15/2022	11/01/2022	NDA/01/01	MG	Leave of Absence-Noon Duty Aide
Rickenbacker, Kim	08/03/2023		R23/S4	EP	New Hire-Office Manager
Rodriguez, Beatriz	07/05/2022		R23/S4	DO	New Hire-Fiscal Clerk for DO
Sanchez, Kris	06/10/2022	06/30/2022	R14/S5	DO	CW/Substitute Summer
Sanchez, Kris	07/01/2022	08/15/2022	R14/S5	DO	CW/Substitute Summer
Sanchez, Kris	06/06/2022	06/30/2022	R14/S5	DO	SCW/Substitute Summer
Sanchez, Kris	07/01/2022	08/15/2022	R14/S5	DO	SCW/Substitute Summer
Serrano, Tena	06/06/2022	06/30/2022	R18/S8	DO	Systems Aide/Summer Assignment
Serrano, Tena	07/01/2022	08/15/2022	R18/S8	DO	Systems Aide/Summer Assignment
Van Hoogmoed, Danielle	06/06/2022	06/30/2022	R30/S1	DO	IA/Substitute/Summer Assignment
Van Hoogmoed, Danielle	07/01/2022	08/15/2022	R30/S1	DO	IA/Substitute/Summer Assignment

C. CLASSIFIED JOB DESCRIPTIONS

- Classified Preschool Teacher with updated Salary Schedule



LOWELL JOINT SCHOOL DISTRICT

PRESCHOOL TEACHER

Classified Salary Schedule

Range 20

JOB SUMMARY:

Under the direction of an assigned supervisor, participate with teachers and other staff in the development, implementation, evaluation and maintenance of a quality State Preschool Program; provide a safe and nurturing environment for the growth and development of children cared for in the Preschool; involve parents and families in student activities.

DISTINGUISHING CHARACTERISTICS:

This classification is distinguished from other teaching classifications in that the primary responsibility is working with students in the State preschool program.

ESSENTIAL FUNCTIONS:

The duties listed below are intended only as illustrations of the various types of work that may be performed. The omission of specific statements of duties does not exclude them from the position if the work is similar, related, or a logical assignment to the class.

- Participate with teachers and other staff in the development, implementation, evaluation and maintenance of a quality State Preschool Program; evaluate program goals, objectives and curriculum; provide a safe and nurturing environment for the growth and development of children cared for in the Preschool.
- Develop and submit lesson plans in accordance with established policies and format; plan and provide instruction and activities to children indoors and outdoors; lead and supervise various activities; take attendance.
- Provide an environment to develop maximum physical, emotional and cognitive development of children; test and evaluate children's progress.
- Involve parents and families in student activities; participate in parent conferences as assigned; provide information and referral services as needed; explain policies, procedures, rules and regulations as needed.
- Provide work direction and guidance to assistants, volunteers and others as required; notify staff of information pertinent to the needs of individual students.
- Model standards of behavior and use a positive approach while working with children, staff and parents; model family-style meals with students.
- Maintain and assure a clean, safe, attractive and positive learning environment; perform light housekeeping duties; consider the use of materials and equipment appropriate for preschool-aged children.
- Maintain and prepare a variety of records and reports; update and organize cum folders and records; conduct and record complex student observations and skill assessments.
- Prepare calendar of events; prepare related schedules and materials for parents.
- Administer routine first aid to students as needed; administer medication and medical procedures in accordance with specific medical instructions.
- Operate a variety of audio-visual, office and instructional equipment; operate kitchen equipment and utensils.
- Perform duties required by Preschool Exemplary Program performance standards and assure compliance with current regulations, licensing and requirements.
- Assist with setting up and cleaning up breakfast, snack and lunch materials; assist students with cleanliness, brushing teeth and toileting as needed.
- Routinely squat, crouch, sit on small chairs, and hard surfaces/floors with students.
- Participate in in-services and training sessions as assigned; attend staff and other meetings as assigned.
- Perform related duties as assigned.

QUALIFICATION GUIDELINES:

Knowledge of:

- Current concepts used in Early Childhood Education.
- Program policies, practices and philosophy.
- Parent involvement techniques.
- Basic child psychology and development. Lesson planning formats and policies.
- Health, safety and nutrition requirements of children. Appropriate safety precautions and procedures.
- Methods of observing, evaluating and recording child behavior. Oral and written communication skills.
- Interpersonal skills using tact, patience and courtesy.

Ability to:

- Plan, develop and implement educational experiences for children cared for in the State Preschool program.
- Develop and maintain effective relationships with children.
- Maintain records and prepare reports.
- Interact with children and adults in an effective manner.
- Implement learning activities for children.
- Maintain a healthy and safe environment.
- Plan and organize work.
- Meet schedules and time lines.
- Establish and maintain cooperative and effective working relationships with others.
- Squat, crouch or sit on small chairs low to the ground or hard floors.
- Train and provide work direction and guidance to others.
- Communicate effectively both orally and in writing.
- Establish and maintain cooperative and effective working
- Lift and move items weighing up to 50 pounds.

Education/Training/Licenses/Experience:

A permit issued by the Commission on Teacher Credentialing authorizing service in the care, development and instruction of children in a child care and development program. This can be either of the following permits:

- Regular Children's Center Instructional Permit
- Limited Children's Center Instructional Permit
- Emergency Children's Center Instructional Permit
- Child Development Master Teacher Permit
- Child Development Teacher Permit
- Child Development Associate Teacher Permit

OR

A current credential issued by the Commission on Teacher Credentialing authorizing teaching service in elementary school or a single subject credential in home economics, and 12 units in ECE and/or CD or two years of experience in early childhood education or a child care and development program.

One year working with children in an instructional capacity. First Aid and CPR certificates.

PHYSICAL STANDARDS AND WORKING CONDITIONS:

The physical and mental demands and work environment described here are representative of those that must be met by employees to successfully perform the essential functions of this class. Reasonable accommodations may be made to enable individuals with disabilities to perform the essential functions. These physical demands are generic in nature and tasks may vary dependent on specific trade and or specialized work assignment.

Physical Demands:

Physical demands of this position include sitting and standing for extended periods of time. The employee may frequently move or lift children weighing up to 50 pounds unassisted. Occasional bending at the waist is required, as is kneeling, crouching, squatting, pushing and pulling. Employees may reach overhead as well as above the shoulders and horizontally.

Mental Demands:

Employee must be able to comprehend and follow written and oral instructions; interpret policies and procedures; and interact cooperatively with District staff, parents, and the general public.

Work Environment:

While performing the duties of this job, the employee works in several environments including classroom, indoor and outdoor environments and on or near student playground equipment.

The information contained in the physical standards description is for compliance with ADA and is not an exhaustive list of duties performed. Individuals who hold this position may perform additional duties and additional duties may be assigned.

LOWELL JOINT SCHOOL DISTRICT
August 8, 2022

To: President Salinas and Members, Board of Trustees

From: Jim Coombs, Superintendent of Schools

Subject: 2022/23 Budget Update

INFORMATION

Education Code Section 42147(h) states: "Not later than 45 days after the Governor signs the annual Budget Act, the school district shall make available for public review any revisions in revenues and expenditures that it has made to its budget to reflect the funding made available by that Budget Act." While this language does not specifically require that districts revise their budgets at this time, it does require making the revisions public if the district decides to make revisions based on the Enacted State Budget.

The Governor signed the 2022-23 State Budget into law on June 27, 2022, beginning the 45-day period, which ends on August 11, 2022. The Board adopted the district budget on June 27, 2022. Due to significant differences between the State Enacted Budget and the proposed budget in the May Revision, which was used to present the 2022/23 Adopted Budget, updates to the Board of Trustees and the public of the significant changes are advisable. Many of these numbers are estimates at this time, and the district's First Interim budget presented on December 12, 2022, will reflect the most current figures available.

AR

Superintendent's Comment:

INFORMATION.

GPR
Mapping
Potholing
Utility Locating
CCTV Pipe Inspection

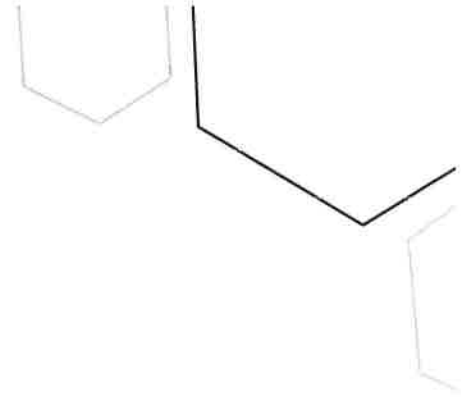

BELOW
SUBSURFACE IMAGING

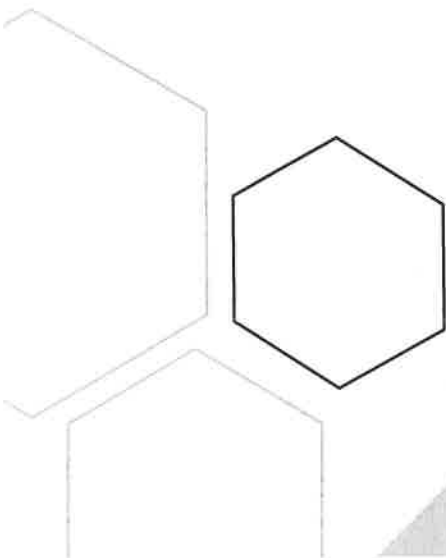

www.cbelow.com
1-888-90-BELOW
14280 Euclid Ave.
Chino, CA 91710
CL# 959964



Estimate
Job 22-5479
Quote No. Q-14143
Date: 06-16-2022
Expires on: 07-16-2022
Payment Prevailing Wage | Net 30

C Below | Subsurface Imaging
Call Before you cut, core, drill or dig.

14280 Euclid Ave Chino, CA 91710
Phone: (888) 902-3569 Fax: (909)606-6555
www.cbelow.com

Bill To

Ghataode Bannon Architects, LLP
760 W. 16th Street, Unit B
Costa Mesa
CA
92627

Opportunity Name

**Rancho Starbuck Utility Locating, Mapping and
CCTV**
Primary

Primary Contact

J. Ben Regalado
714-665-8030
bregalado@gbarchitects.net

Jobsite Address

Sales Rep	Ext.	Email	Cell
Victoria Franco	210	victoriaf@cbelow.com	

C Below, Inc. submits this proposal for the Rancho Starbuck Utility Locating, Mapping and CCTV project. Our proposal is based on the enclosed estimated hourly breakdown and the C Below Schedule of Fees. In order to successfully complete the outlined scope of services in this proposal our field technicians will need uninterrupted clear access to the work area and the appropriate project documentation. We appreciate the opportunity to provide you with our services and look forward to helping assure a safe and successful project.



14280 Euclid Avenue
Chino, CA 91710

Utility Locating Scope of Work

C Below will provide a comprehensive Utility Investigation of the outlined area shown on Exhibit A (last page of proposal).

The purpose of this investigation is to find all utilities outlined below to quality level (QL) B per ASCE 38-02. (see attached documentation on available quality levels).

C Below will exhaust any and all utility locating methods, plus "tribal knowledge", to positively identify the horizontal and vertical locations of the utility lines.

This includes utilizing the equipment listed below:

- *Electromagnetic Locator (Locator)*
- *Locatable CCTV Push Camera. No video will be provided unless specifically included in your quote. (Push Cam)*
- *Ground Penetrating Radar (GPR).*
- *Locatable Duct Rodder (Ram Rod).*
- *Crawler Camera and lateral Launch Equipment if specifically included in your quote. (Crawler)*

Deliverables- Utility locations along with depth estimates will be marked directly on the surface (Please reference your Markings Card for explanations of these.



14280 Euclid Avenue
Chino, CA 91710

Mapping Scope of Work

At the completion of this project the client will be provided a comprehensive 2D utility map in CAD and PDF. Client shall provide CAD background for utilities to be added to. While our maps do include utility depth estimates from the surface, survey elevations are not included unless specifically requested at the time of this estimate.

PHASE 1 | Utility Mark Out w/ Waterbased Paint. Utility marks will remain on the site unless the client has hired C Below to remove the markings.

PHASE 2 | C Below's Mapping Team will pick up the markings with the depth estimates from PHASE 1. Mapping shall be completed within a reasonable time frame to assure integrity of marks.

PHASE 3 | Quality review with the Lead Technicians and the Mapping Team to ensure the quality of the deliverable and applicable notes.



14280 Euclid Avenue
Chino, CA 91710

CCTV Scope of Work

C Below will perform CCTV pipe inspection on Sewer and/or Storm Drain lines within the marked area of investigation on the attached exhibit.

CCTV cannot be performed on blocked lines, laterals that are inaccessible, or lines that are full. It is recommended that Jetting be performed on lines that are blocked only to assist with our CCTV inspection.

CCTV Inspection does not include removal of toilets for access or mapping of line locations.

Client will be provided with a digital file and report of the inspection. Line sizes in these reports are estimates of the interior and may vary.



Estimate
Job 22-5479
Quote No. Q-14143
Date: 06-16-2022
Expires on: 07-16-2022
Payment Prevailing Wage | Net 30

Product Line Items

Product	Quantity	Sales Price	Total Price
Admin	2	\$95.00	\$190.00
CCTV Report	1	\$250.00	\$250.00
CCTV Robotic Camera Pipe Inspection	8	\$385.00	\$3,080.00
Drafting	4	\$125.00	\$500.00
Locating Locating Technician	28	\$175.00	\$4,900.00
Locating Supervising Technician	28	\$195.00	\$5,460.00
Mapping	12	\$230.00	\$2,760.00
Mobilization Crew	5	\$225.00	\$1,125.00
Mobilization Single Tech	2	\$135.00	\$270.00
Project Coordinator	4	\$95.00	\$380.00
Total USD			\$18,915.00

Product Descriptions

Product Item	Description
Admin	Project Administration.
CCTV Report	CCTV Report including observations and photos.
CCTV Robotic Camera Pipe Inspection	Robotic Pipe Inspection. Includes locating and video.
Drafting	Drafting for utility findings.
Locating Locating Technician	Locating Locating Technician
Locating Supervising Technician	Locating Supervising Technician
Mapping	Mapping of utility findings.
Mobilization Crew	Mobilization Crew
Mobilization Single Tech	Mobilization Single Tech



Estimate
Job 22-5479
Quote No. Q-14143
Date: 06-16-2022
Expires on: 07-16-2022
Payment Prevailing Wage | Net 30

Project Coordinator	Project Coordinator
---------------------	---------------------

Quality Level Definitions

Quality Level D is the most basic level of information for utility locations. It comes solely from existing utility records or verbal recollections, both typically unreliable sources. It may provide an overall "feel" for the congestion of utilities, but is often highly limited in terms of comprehensiveness and accuracy. QL-D is useful primarily for project planning and route selection activities.

Quality Level C involves surveying visible utility facilities (e.g., manholes, valve boxes, etc.) and correlating this information with existing utility records (QL-D information). When using this information, it is not unusual to find that many underground utilities have been either omitted or erroneously plotted. Its usefulness, therefore, is primarily on rural projects where utilities are not prevalent, or are not too expensive to repair or relocate.

Quality Level B involves the application of appropriate surface geophysical methods to determine the existence and horizontal position of virtually all utilities within the project limits. It addresses problems caused by inaccurate utility records, abandoned or unrecorded facilities, and lost references. Decisions regarding location of storm drainage systems, footers, foundations and other design features can be made to successfully avoid conflicts with existing utilities. Slight adjustments in design can produce substantial cost savings by eliminating utility relocations.

Quality Level A is the highest level of accuracy and involves the full use of the subsurface utility investigation method. It provides information for the precise plan and profile mapping of underground utilities through the nondestructive exposure of underground utilities, and also provides the type, size, condition, material and other characteristics of underground features.

Service Exceptions and Limitation

Locating Exceptions

Our services do not include the location of irrigation lines and associated control valves. We are able to locate sewer and storm drain lines if access is made available. We do not locate abandoned/extra conduits containing no interior cable and we do not locate fiber optic lines or lines without a metallic shield or lacking a tracer wire. C Below has the ability to locate nonmetallic lines but it is outside our normal scope of services. Should the need arise to locate these types of lines, please contact us for an additional quote.

GPR Exceptions

There needs to be at least 8 inches clearance around the perimeter of the scanning area to accommodate the GPR antenna; especially at structure intersections. Scanning surfaces need to be relatively flat with no water present. GPR can penetrate 12 inches of concrete or masonry, but accuracy decreases with increased steel congestion. Indications show up on the radar screen as hyperbolas. The center of the hyperbola is the center of the indication. GPR data, under most circumstances, does not allow for the interpretation of an indications size, only the center location of the indication and embedment depth. Indications such as reinforcing steel or conduit spaced closer than 2 inches on center may show up as one indication.

Mapping Exceptions

Please be sure to provide any project documents prior to dispatch. A workable CAD file is required if mapping is to be performed. JPG, TIFF, PDF files are not preferred and may affect the quality of the final product. If no CAD file can be provided, additional costs may apply. A complete and editable background must be provided by the client to ensure the quality of the final product.

Potholing Exceptions

For billing purposes, C Below defines a standard pothole with the dimensions of 1' X 1' X 5' deep. Deviations from this standard definition require rate increases for additional time and materials to facilitate the client requests. Because potholing rates and other associated costs are based on the assumption of 8 hour work days, additional fees may apply if work is limited to less than 8 hours per day. These fees may include, but are not limited to: additional traffic control, travel time, and disposal fees. Standard pothole pricing includes holes at locations with a soil surface or an asphalt surface up to 6-inches thick. Additional fees will apply if the asphalt surface is over 6" thick or the proposed hole location has a concrete surface. If during the potholing operation the soil is found to have large aggregate or other debris over 3-inches in diameter, ground water, roots or hazardous materials, additional fees will apply. For further clarification please speak to your C Below representative. Optional Services include: hot patching per City requirements, slurry backfill, standard or engineered traffic control plans, trenching or excavation beyond standard pothole dimensions.

CCTV Exceptions

All lines designated by the client for need of inspection must have clear unobstructed access points. Information gathered during the inspection must be agreed upon prior to dispatch. For added scope of water jetting additional fees apply.

Traffic Control

Standard Traffic Control includes one lane closure with minimal signage not spanning an intersection. Extensive Traffic Control includes multiple lane closures, arrow boards, multiple signage requirements, spanning of intersections, flaggers, and other non-standard setups.

General Terms and Conditions for Services

Provided by C Below, Inc.

For the remainder of this document, C Below, Inc. will be referred to as CBI and the Owner or Owner's representative will be referred to as the CLIENT.

ANTICIPATED COSTS

CBI's estimated budget is based upon information provided by the Client. Our ability to perform within the estimated budget depends heavily on the accuracy of the information provided, as well as the cooperation and attentiveness of the Client's management staff. Our accounting department will provide the Client with a percentage of the estimated budget used on each invoice. The Client's management staff shall monitor the percentage of work remaining to assure CBI's services are not greater than the estimated budget. If CBI performs less work than the estimated budget, the Client's costs will be less. Likewise, if the duration of our services exceeds our estimated budget, the Client will incur more cost. Verbal requests made by project representatives to perform services beyond our estimated budget are considered authorization to perform billable work. Project actual budget totals may vary. Estimated budget hours are based on a 40-hour/Monday - Friday workweek, 8-hours per day, excluding weekends, holidays and overtime. The Client agrees that any "budget estimates", "anticipated costs" or other like documentation prepared by CBI is NOT a "not to exceed budget", "guaranteed maximum" or "lump sum". The Client will be invoiced for all work performed based on CBI's Schedule of Fees and these Terms & Conditions.

MINIMUM CHARGES

All locating services are based on a minimum of four hours. Over four hours shall be a minimum of eight hours. If a technician is scheduled to perform a service and no work is performed, a two hour minimum charge shall apply (show-up charge).

WORKING HOURS

CBI's regular workweek is Monday - Friday. Normal work hours are 7:00 am – 5:00 pm. For work performed Monday – Friday, overtime hours (1.5 times the contracted hourly rate) apply after eight hours worked per day. Premium time hours (2 times the contracted hourly rate) apply after twelve hours worked per day. Work performed on Saturday shall be billed at 1.5 times the contracted hourly rate. Work performed on Sundays and Holidays shall be billed at 2.0 times the contracted hourly rate. Holidays observed by CBI are New Year's Day, Memorial Day, Independence Day, Labor Day, Veterans Day, Thanksgiving, the day after Thanksgiving and Christmas. Overtime hour charges shall be in one-hour increments.

SCHEDULING & CANCELLATION

A minimum of 24-hours notice is required when scheduling CBI's services. If services are requested the same day or after 2:00 pm the preceding day, a premium expedite fee of \$75 per technician will apply. If services are canceled less than 24-hours before the scheduled start time, a fee of \$75 per technician will apply.

PREVAILING WAGE

The prices quoted within are NOT Prevailing Wage or Union unless specifically stated on the first page of this document. If this project requires Prevailing Wage, our hourly rates will increase the proportional percentage increase every July 1 in accordance with the wage listed by the Director of Industrial Relations which is tied to any applicable union or collective bargaining agreement documented annual increases plus corresponding changes in our general administration and overhead expenses. These adjustments shall become the agreed upon basis for charges by CBI to the Client.

CERTIFIED PAYROLL

Certified payroll requests will have a processing fee applied for each project, billed on every invoice in the amount of \$75.00.

C.O.D.

Projects totaling less than \$5,000.00 in services for Clients that have not submitted credit approval through the CBI accounting department shall be performed on Cash on Delivery (C.O.D.) basis. Prior to the start of our services the CBI technician will collect a check from the Client. For all other projects, please see the TERMS OF PAYMENT section of this document.

TERMS OF PAYMENT

The Client agrees invoices rendered for professional or technical services will be prepared bi-monthly and are due upon presentation. Invoices will be deemed past due if unpaid within thirty (30) days from date of invoice, and will be subject to a monthly finance charge of 1.5% of invoice total for each month unpaid. All invoice errors or necessary corrections shall be submitted to CBI within fifteen (15) days of receipt of the invoice; thereafter the Client acknowledges the invoice is correct and valid for payment due to CBI. CBI reserves the right to terminate services to the Client without notice if the Client's account is not paid currently. Upon such termination of services, the entire amount accrued for all services performed shall immediately become due and payable to CBI. The Client waives any and all claims against CBI, its subsidiaries, affiliates, servants and agents in connection with termination of work/services pursuant to this agreement. In the event CBI deems it necessary to refer a past due account to an attorney or to file suit for collections, the Client agrees to pay all actual expenses and costs incurred there by, including CBI staff costs, actual attorney fees & costs, and all related costs in such litigation. Jurisdiction and venue of all such actions and any other actions arising from this agreement or the provision of services by CBI shall be in San Bernardino County, State of California.

INSURANCE

CBI carries all insurance required by law. Additional insurance coverage can be obtained at an additional cost to the Client. These costs can be obtained by quotation from CBI. CBI will process Waiver of Subrogation, Additional Insured's, and Additional insurance certificates upon request from the Client. An additional charge of \$150 will apply for each document required and will be invoiced to the Client.

REIMBURSABLE EXPENSES

Outside services performed by others and direct costs expended on the Client's behalf, are charged at cost plus 15%. Equipment and materials purchased/rented by CBI exclusively for the project will be invoiced at cost plus 15%. Business license fees for project specific requirements will be invoiced at cost plus 15%.

SERVICE AUTHORIZATION

Verbal request will be considered authorization to perform billable work. The Client shall designate member(s) of their staff who have authority to request our services and notify CBI in writing as to their authorized representative. Otherwise all service requests are billable.

PROPOSAL VALID DURATION

Proposed Master Fee Schedule of Rates, Term & Conditions and General Conditions stated within are valid for 30 days from proposal date.

CONTRACTUAL ADDITIONS

C Below will undertake professional responsibility for only the services provided pursuant to this Agreement, and only pursuant to the terms and conditions of this Agreement. In particular, and without limitation, C Below will not be responsible for delays or other matters beyond its reasonable control; for inaccurate or incomplete information provided to it by Client, co-consultants or other reasonably reliable sources; for site conditions of which it was not actually informed; for unauthorized modifications to or deviations from C Below's instruments of service or the use of unfinalized instruments of service for any purposes including bidding or cost estimating; for hazardous materials or toxic substances at the Project site; for the specification of products or equipment for purposes consistent with the manufacturer's published literature; for materials and equipment decisions made by others; for the services and instruments of service provided by others even if incorporated into C Below's instruments of service for ease of reference or otherwise; for the performance of the Project's contractors and materials suppliers; for construction means, methods, techniques, sequences or procedures, including without limitation investigation or demolition procedures and safety precautions and programs; and for the actions or inactions of others including utility companies, other consultants and governmental or quasigovernmental agencies.

The services being provided for by C Below do not relieve the Client of the responsibility of having to comply with California Government Code §§4216 - 4216.9. It is expressly understood by the Client that C Below's services are not a substitute for compliance with California government Code §§4216 - 4216.9.

In recognition of the relative risks, rewards and benefits of the project to both the Client and C Below, the risks have been allocated such that the Client agrees that, to the fullest extent permitted by law, C Below's total liability to the Client and to any other third party for any and all injuries, claims, losses, expenses, damages or claims expenses arising out of this agreement from any cause or causes, shall not exceed C Below's fee or \$5,000.00, whichever is less. Such causes include, but are not limited to, C Below's negligence, strict liability, breach of contract or breach of warranty.

The Client waives all rights against C Below for damages caused by fire, water, wind or any other perils to the extent covered by any type of property insurance applicable to the claimed damage or loss. This waiver of subrogation shall be effective even though that person or entity would otherwise have a duty of indemnification.

The Client shall ensure that all of its contractors and subcontractors maintain General Liability Insurance (minimum of \$1,000,000 per occurrence limits of coverage). Modified occurrence policies are not acceptable; any coverage exclusion in addition to standard ISO coverage forms must be noted and approved by C Below. The Client will require and make certain that its contractors and subcontractors list C Below as an additional insured using ISCO CG2010 1985 Form B or equivalent with no limitation to "ongoing operations" for each project C Below performs services for the Client. The additional insured endorsement or certificate must also contain a statement that "the protection afforded the additional insured hereunder shall be primary and any other coverage available to the additional insured shall be excess and non-contributing."



14280 Euclid Ave
Chino, CA 91710
1-888-90-BELOW
Fax: (909) 606-6555

UTILITY LOCATING

Utility locating is an imperative first step prior to geotechnical excavation during pre-construction. Damaged lines are not only expensive to repair but can be extremely dangerous. Starting your project with the knowledge of the types and locations of underground utilities on the job site is an important and cost-effective way to ensure a safe and successful project.

C Below has the ability to locate horizontal and vertical locations for all underground utilities including: water, gas, power, waste, communications and cable/TV.

Our technicians will mark all indications directly on the surface of all surveyed areas using the American Public Works Association (APWA) Uniform Color Code. All utility locating marks are made in accordance with the Common Ground Alliance (CGA) Best Practices.

Once lines have been found, there are several options a technician can use for marking the utility locations. Spray paint is the most common but flags or whiskers are also utilized in areas that have heavy traffic, or where sprinklers may cause the paint to become unreadable prior to excavation. Computer-aided design or CAD drawings of our findings can also be provided upon request.

Our utility locating services shall include only those materials commonly used for locating and marking indications. Clear access to scanning areas need to be provided by the client. Should the area to be scanned not be accessible from the ground, the client will provide the means (man lift, scaffold, etc.) for our technician to properly perform their work.

For utility locating we locate all underground utilities using a standard electromagnetic utility locator. With this method, we are able to find: main water supply lines and associated branch lines made of metal (conductive) or water lines installed with a "tracer wire", all sewer and waste lines by electromagnetic location, power lines, telecommunication lines, gas lines with tracer wires.

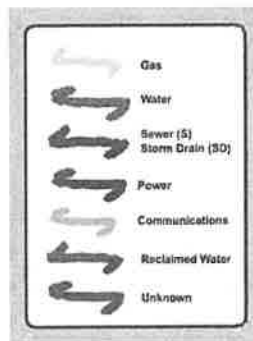

EXCEPTIONS

Our services do not include the location of irrigation lines and associated control valves. We are able to locate sewer lines if access is made available. We do not locate abandoned/extra conduits containing no interior cable and we do not locate fiber optic lines or lines without a metallic shield or lacking a tracer wire. C Below has the ability to locate nonmetallic lines but it is outside our normal scope of services. Should the need arise to find these types of lines, please contact us for an additional quote.





14280 Euclid Ave
Chino, CA 91710
1-888-90-BELOW
Fax: (909) 606-6555

GROUND PENETRATING RADAR (GPR)

C Below uses GPR for locating reinforcing steel, prestressing strand, conduit and other indications in concrete and masonry structures. We use this method because it is one of the safest, fastest and most accurate methods currently available. With the ability to penetrate up to 18 inches of concrete, our technicians can map all indications directly on the scanning surface prior to coring, cutting or drilling. The survey results can also be saved and printed in 3-Dimensional detail providing a subsurface map for our client.

With such a large penetration range, GPR can be used with access to only one side of the scanning area with no need to place film on the opposite surface (as is needed with other methods). Our technicians determine the thickness of concrete and masonry structures to determine the spacing and depth of indications. In certain cases, the size of the indication can be estimated.

As these indications are found, they are displayed to the technician in real-time. They are displayed on the GPR monitor when changes in the conductivity of the scanned area represent locations of rebar, conduit, pipe, voids, and other objects located beneath the surface. Once located, the indication is marked in accordance with the APWA Uniform Color Code.

GPR is incredibly versatile and offers ease of use on job sites. It emits about 1% the power of a cell phone signal to perform its functions. Other methods require a safety perimeter around work areas. We prefer to use GPR because we are able to work in occupied sites and buildings where temporary evacuation is not an option. The equipment is very portable and can be moved to location quickly, making scanning of multiple areas a fast, efficient and manageable process. The practicality of this service supersedes traditional methods of utility locating, but it can also be used in conjunction with them.

With the ability to locate nonmetallic utilities up to 12 feet deep, you can be sure most lines will be identified.

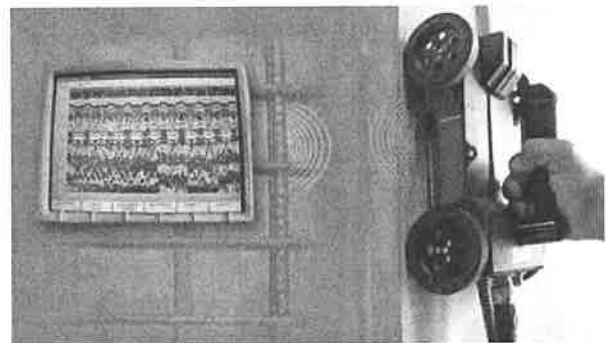

EXCEPTIONS

There needs to be at least 8 inches clearance around the perimeter of the scanning area to accommodate the GPR antenna; especially at structure intersections. Scanning surfaces need to be relatively flat with no water present. GPR can penetrate 16 inches of concrete or masonry, but accuracy decreases with increased steel congestion. Size of indications are hard to determine as GPR readings are presented in a fashion that communicates location rather than the indication's expanse.

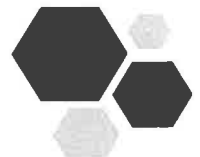



14280 Euclid Ave
Chino, CA 91710
1-888-90-BELOW
Fax: (909) 606-6555

UNDERGROUND MAPPING

C Below will provide our client with electronic and/or printed documentation of our utility investigation when mapping is added to our locating scope of work. Utility locations will be plotted in a client provided site drawing with clear, easy to read detail. Each utility is labeled and color coded in accordance with the indications marked in the field. We prepare CAD drawings to ensure the industry's most accurate drawings. The details of these drawings are based upon client specifications. Some of these options include depth, pipe diameter and materials, connection points, and all unknown utilities.

In addition to 36" x 24" prints, our drawings can also be saved in PDF format for simple distribution and viewing. Our detailed drawings can be used to provide designers and contractors with an overview of what to expect when performing site work. All mapping is done under the supervision of a licensed civil engineer.



ADDITIONAL SURVEYING SERVICES

In addition to mapping our utility location markings, we offer a full range of surveying services.

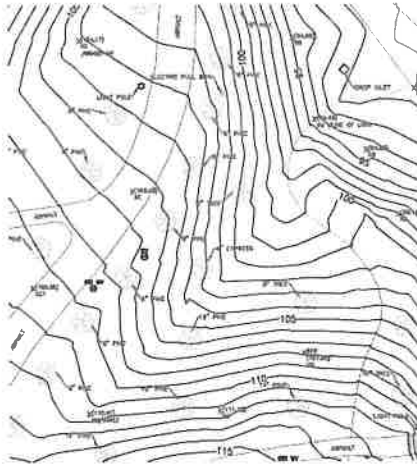

- ADA**
- BOUNDARY**
- A.L.T.A./N.S.P.S**
- TOPOGRAPHIC**
- CROSS-SECTIONS**
- ENCUMBRANCE MAPS**
- ORTHO AERIAL PHOTOS**

EXCEPTIONS

Please be sure to provide any project documents prior to dispatch. A workable CAD file is required if mapping is to be performed. JPG, TIFF, PDF files are not preferred and may affect the quality of the final product. If no CAD file can be provided, additional costs may apply. A complete and editable background must be provided by the client to ensure the quality of the final product.



POTHOLING

Potholing is also known as vacuum excavation and is used for the purpose of identifying the axis of an underground utility. When the utility is revealed, the type of material and utility size are documented. The data collected during these excavations are beneficial in all phases of construction. Based upon the soils conditions or scope, C Below will choose to use air or water to create the pothole. Potholes made to expose facilities encased in concrete, will stop at the encasement. The top of the encasement will then be recorded as the top of the facility.

After documenting our findings, each pothole will be backfilled, compacted, and a perm-a-patch or hot patch will be provided depending upon client specifications.

A potholing report complete with photographs are provided at the conclusion of the job documenting the location, utility found, depth to top of pipe, utility size, material and the soil conditions. If no utility is found within the predetermined depth of the pothole, it will be considered a dry hole. Additional holes may be necessary to provide a positive location of the utility.



C Below technicians performing potholing

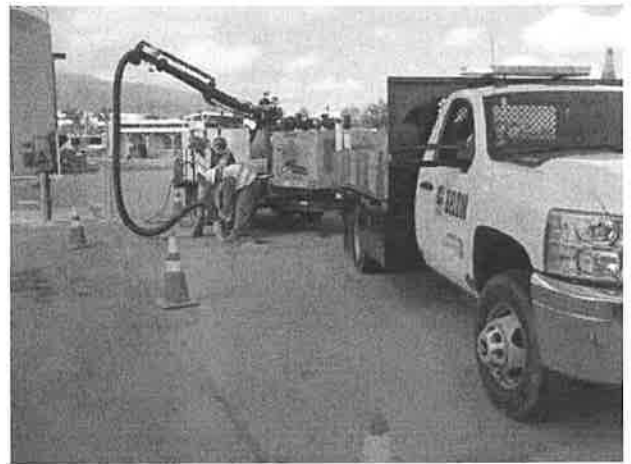

Potholing equipment

PRICING & EXCEPTIONS

For billing purposes, C Below defines a standard pothole with the dimensions of 1' X 1' X 5' deep. Deviations from this standard definition require rate increases for additional time and materials to facilitate the client requests. Because potholing rates and other associated costs are based on the assumption of 8 hour work days, additional fees may apply if work is limited to less than 8 hours per day. These fees may include, but are not limited to: additional traffic control, travel time, and disposal fees. Standard pothole pricing includes holes at locations with a soil surface or an asphalt surface up to 6-inches thick. Additional fees will apply if the asphalt surface is over 6" thick or the proposed hole location has a concrete surface. If during the potholing operation the soil is found to have large aggregate or other debris over 3-inches in diameter, ground water, roots or hazardous materials, additional fees will apply. For further clarification please see rate sheet for 'Out of Scope Hole' and the table below. Optional Services include: hotpatching per City requirements, stamped traffic control plans by an engineer, routine traffic control plans.





14280 Euclid Ave
Chino, CA 91710
1-888-90-BELOW
Fax: (909) 606-6555

CCTV PIPE INSPECTION AND CRAWLER CAM

C Below provides video pipe inspection that will give vital information to help properly maintain utility and pipe facilities. We perform this service on sanitary sewer and storm drain lines specifically identified by the client or client's representative. CCTV pipe inspection includes trained personnel and the use of a push camera and/or crawler camera depending on the size of the line.

During this inspection, videos are recorded in full color MP4 files that can be viewed easily on all computers. Captions can be added to the video to help identify the technician findings. Our push cameras can video lines as small as 3" in diameter while our crawler cameras can do pipes upwards of 72". The video technology offers high quality assessment of all piping, including joints. We offer quick results with the ability to transfer video feed via USB and Bluetooth technology.

Standard details recorded during the inspection include: obstructions or blockages, root intrusion, structural damage, pipe offsets and flow conditions. Problem areas found will be identified on the surface for easy identification.

In the event that any blockage is found, we are able to provide water jetting to clear the obstructions. Sanitary Sewer and Storm Drain lines may contain debris and blockages that limit the ability to perform CCTV Pipe Inspection. C Below can arrange for an outside contractor to jet all lines prior to CCTV pipe inspection to ensure the full length of the pipe can be filmed.



CCTV Crawler Cam

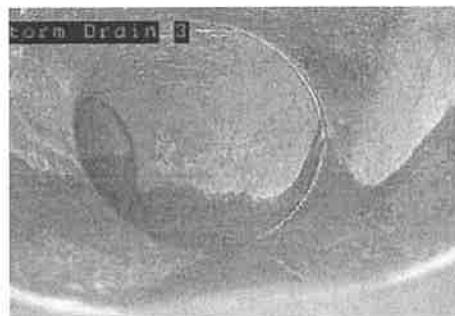

Intact and damaged storm drains as recorded by our CCTV

EXCEPTIONS

All lines designated by the client for need of inspection must have clear unobstructed access points. Information gathered during the inspection must be agreed upon prior to dispatch. For added scope of water jetting additional fees apply



Exhibit A

Area of Investigation

Legend

Woodbrier Dr

Wood

Woodbrier Dr

Google Earth

300 ft

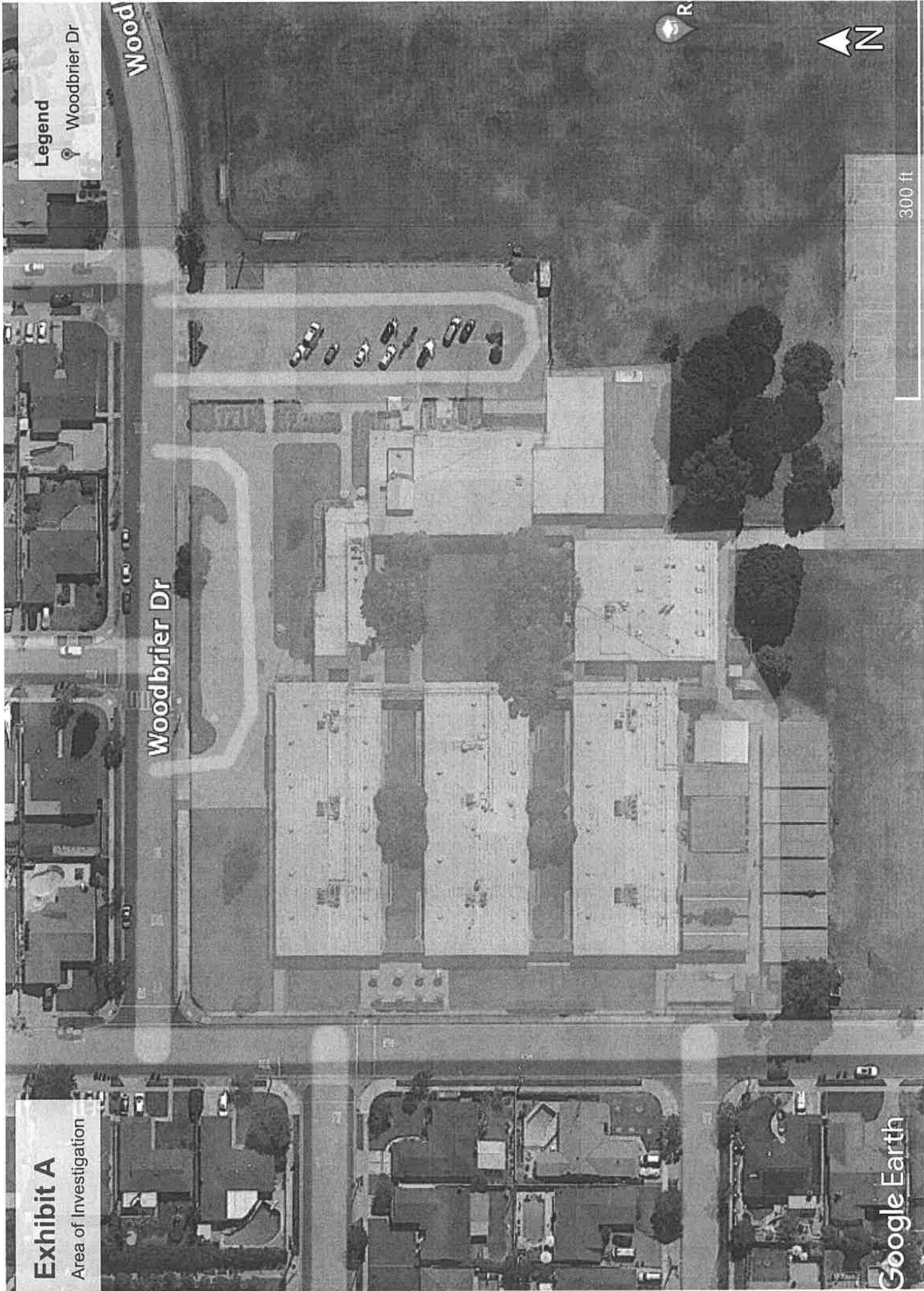



Job 22-5479
Quote No. Q-14143
Date: 06-16-2022
Expires on: 07-16-2022
Payment Prevailing Wage | Net 30

Please review all pages in this agreement on our services capabilities and limitations before signing. Should you have any questions about our services, please contact your sales representative before signing this agreement.

Signature:

Effective Date:

Name (Print):

Title:

Client Billing Information

Bill to Name

Attention

Address

City

State

Zip

Email

C Below Signature:

Effective Date:

C Below Name (Print): Ashley Salvino

Title: Vice President of Operations

Please sign and email to Victoria Franco at victoriaf@cbelow.com.

After C Below receives this signed agreement, **Dispatch** will be notified immediately to begin the scheduling process. Service availability changes throughout the day. Service date and time can only be confirmed by dispatch after receiving this agreement.

THANK YOU FOR YOUR BUSINESS!

LOWELL JOINT SCHOOL DISTRICT
August 8, 2022

To: President Salinas and Members, Board of Trustees

From: Jim Coombs, Superintendent of Schools

Subject: Ratification of Additional Professional Services Agreement
with A-Tech Consulting for Hazardous Materials Monitoring,
at Meadow Green Elementary School

ACTION/
(RATIFICATION)

Background:

On June 11, 2018, the Lowell Joint School District Board of Trustees approved Resolution 2018-19 No. 724 ordering a School Bond Election. On November 6, 2018, the voters in the Lowell Joint School District passed measure LL. A part of Measure LL includes the repairs and upgrades to District facilities. This expenditure is subject to the purview of the Citizens Bond Oversight Committee.

Current Considerations:

Unlike the Public Works competitive bidding process, Professional Service providers can be selected on the basis of their qualifications, services they provide and their value to the District.

In March 2019, the District issued an RFQ for Hazardous Materials Surveying and Testing providers. Based on the results of the scoring, A-Tech Consulting was selected to provide the District with environmental testing and identification services prior to the Meadow Green Elementary HVAC, Roofing and Fire Alarm project. On June 13, 2022, the Board of Trustees approved a Professional Services Agreement with A-Tech to perform Hazardous Materials Assessment Services at Meadow Green Elementary School for \$14,487.

In order to complete a thorough sampling, the District is requesting that A-Tech conduct the Asbestos Clearance Monitoring as well. The increase in scope resulted in an additional fee of \$4,475. This increased the total amount of the proposal to \$18,962.

Financial Implications

Financial Impact:	\$4,475.00
Funding Source:	Measure LL General Obligation Fund – Fund 21.0

Superintendent's Comment:

APPROVAL RECOMMENDED.

Recommendation:

It is recommended that the Board of Trustees ratify the additional Professional Services Agreement with A-Tech Consulting for Hazardous Materials Monitoring at Meadow Green Elementary School, effective August 9, 2022 through August 8, 2023, not to exceed \$4,475.00 (21.0-00000-0-00000-85000-6282-0040000) Measure LL (21.0 Bond Fund), and that the Superintendent or designee be authorized to execute the necessary documents.

Superintendent's Comment:

APPROVAL RECOMMENDED.



July 11, 2022

Lowell Joint School District
11019 Valley Home Avenue
Whittier, California 90603

Attn: Mr. David Bennett

Re: Meadow Green Elementary School
12025 Grovedale Drive, Admin Building, Various Areas
Whittier, California 90604

Dear Mr. Bennett,

Thank you for allowing A-Tech Consulting, Inc. (*A-Tech*) the opportunity to provide you with a cost proposal. This proposal is in response to your request that *A-Tech* conducts the Asbestos Project Monitoring and Asbestos Clearance Monitoring at the above referenced site.

The professional services provided by *A-Tech* will consist of the following:

ASBESTOS PROJECT MONITORING

- Full-time, on-site project observation of the project by a Cal-OSHA certified asbestos CSST or CAC, as required by law.
- Provide on-site air analysis (set up microscope on-site) per regulated area upon completion of removal and ensure that no fibers migrate from regulated areas.
- Air sample analysis to be performed by a NIOSH 582 Equivalency certified microscopist.
- Background, General and Clearance air sampling, in accordance with EPA protocols and analyzed by Phase Contrast Microscopy (PCM) using NIOSH 7400 "A" counting rules.
- Review and verification of asbestos abatement contractor's pre-project submittals (e.g. certifications, medical surveillance, SDS, respiratory protection plan, safety minutes, etc.) and act as a liaison between regulatory agencies, contractors and client.
- Closeout documentation detailing all abatement, monitoring and clearance results including air monitoring report and a clearance certificate OR clearance documentation including a clearance letter and air sampling logs.

ASBESTOS (TEM) CLEARANCE SAMPLING

- Visual clearance inspection of all completed abated areas. "White Glove" method clearance inspection will be conducted in accordance with AHERA regulations.
- Asbestos (TEM) clearance sampling by a state certified asbestos consultant or certified site surveillance technician, utilizing AHERA regulated sampling protocols.
- Samples to be collected by a high-volume air sampling pump calibrated with a rotameter, utilizing 25 mm MCE filters with pore size <0.45 microns utilizing aggressive air sampling (leaf blower and/or fans) protocol as required in the AHERA regulations.
- Analysis of samples by an NVLAP accredited laboratory, utilizing Transmission Electron Microscopy (TEM), in accordance with current AHERA/ASHARA regulatory requirements. The quoted sample analysis is based on 24 Hour laboratory analysis.
- Clearance documentation detailing all materials removed, locations of removal, air sampling logs and laboratory reports.



PRICING

Based on the information gathered, we propose to provide the following professional consulting services:

ASBESTOS PROJECT MONITORING AND ASBESTOS CLEARANCE

Item	Price		Qty	Line Total
Asbestos Project Monitoring, (8-Hour Shift)	\$1,250.00/Shift	X	3	\$3,750.00
Asbestos TEM Samples (TEM-AHERA)	\$145.00/Sample	X	5	\$725.00
			Total	\$4,475.00

I trust that this proposal will meet with your approval and look forward to working with you. Should you have any questions, please feel free to contact me at (714) 434-6360 office.

Sincerely,

A-Tech Consulting, Inc.

Joseph A. Williams, CAC, DPH
CAC #14-5269 DPH #19524
joew@atechinc.net

To proceed with scheduling, kindly reply to PM@atechinc.net and accounting@atechinc.net

LOWELL JOINT SCHOOL DISTRICT
August 8, 2022

To: President Salinas and Members, Board of Trustees

From: Jim Coombs, Superintendent of Schools ACTION

Subject: Approval of Prime Contract Change Order #002, to Increase the Guaranteed Maximum Price with Erickson Hall Construction Company, Inc. to Replace the Main Switch Board at the Meadow Green Elementary School Project

Background:

On June 11, 2018, the Lowell Joint School District Board of Trustees approved Resolution 2018-19 No. 724 ordering a School Bond Election. On November 6, 2018, the voters in the Lowell Joint School District passed measure LL. A part of Measure LL includes the repairs and upgrades to District facilities. This expenditure is subject to the purview of the Citizens Bond Oversight Committee.

On April 4, 2022, the Board of Trustees approved a Resolution for the Guaranteed Maximum Price (GMP), and the Lease-Leaseback Contract with Erickson Hall Construction Company for the HVAC, Roof Replacement, Fire Alarm, and Related Work at Meadow Green Elementary School.

Current Considerations:

On April 4, 2022, the Board of Trustees approved the Guaranteed Maximum Price of \$5,732,107 with Erickson Hall Construction Company, Inc., HVAC, roofing, and associated electrical project at Meadow Green Elementary School. The increased loads to the existing electrical switch board place it very close to its maximum capacity. This change order adds the material and labor for the purchase and installation of a new electrical main switch board.

Financial Implications:

Financial Impact:	\$71,686.00
Funding Source:	Measure LL General Obligation Fund – Fund 21.0

Recommendation:

It is recommended that the Board of Trustees approve Prime Contract Change Order #002 to increase the Guaranteed Maximum Price with Erickson Hall Construction Company, Inc. for

Superintendent's Comment:

APPROVAL RECOMMENDED.

the replacement of the main switch board at the Meadow Green Elementary School Project, effective August 9, 2022 through August 8, 2023, not to exceed \$71,686 (21.0-00000-0-00000-85000-6210-008000) Measure LL (21.0 Bond Fund), and that the Superintendent or designee be authorized to execute the necessary documents.

Superintendent's Comment:

APPROVAL RECOMMENDED.



PCCO #002

Erickson-Hall Construction Co.
 500 Corporate Drive
 Escondido, California 92029
 Phone: (760) 796-7700
 Fax: (760) 796-7750

Project: 4204 - Meadow Green ES
 12025 Grovedale Drive
 Whittier, 90604

Prime Contract Change Order #002: Replace MSB per RFI 002 and RFI 006

TO:	Lowell Joint School District 11537 Grovedale Dr. Whittier, California 90604	FROM:	Erickson-Hall Construction Co 500 Corporate Drive Escondido, California 92029
PCCO NUMBER/REVISION:	002 / 0	CONTRACT FOR:	4204:Meadow Green ES Prime Contract
DATE CREATED:	7/21/2022	SUBMITTED DATE:	
SCHEDULE IMPACT:		TOTAL AMOUNT:	\$71,686.00

DESCRIPTION:
 The following pricing is for replacing the existing main switchboard and installing a new Eaton switchboard per the response of RFI 002 and RFI 006. Included in the cost is the credit for the two breakers per E002, the demolition of the existing gear and the installation of the new switchboard. Excluded in the cost is the coordination with Southern California Edison and any changes associated with their design.

ATTACHMENTS:

Potential Change Orders in this Change Order

PCO #	Title	Schedule Impact	Amount
CO #2	Replace MSB per RFI 002 and RFI 006		\$71,686.00
Total:			\$71,686.00

The original (Contract Sum)	\$5,732,107.00
Net change by previously authorized Change Orders	\$94,950.00
The contract sum prior to this Change Order was	\$5,827,057.00
The contract sum would be changed by this Change Order in the amount of	\$71,686.00
The new contract sum including this Change Order will be	\$5,898,743.00

Execution of this Potential Change Order will revise the contract value as indicated and may change the contract duration.
 Contractor reserves it's right to request additional time and/or cost once the full extent or cumulative nature of the contract change(s) become known.

Ghataode Bannon Architects
 760 W 16th Street Unit B
 Costa Mesa, California 92627

Lowell Joint School District
 11537 Grovedale Dr.
 Whittier, California 90604

Erickson-Hall Construction Co
 500 Corporate Drive
 Escondido, California 92029

SIGNATURE

DATE

SIGNATURE

DATE

SIGNATURE

7/21/2022

DATE



PCO #CO #2

Erickson-Hall Construction Co.
500 Corporate Drive
Escondido, California 92029
Phone: (760) 796-7700
Fax: (760) 796-7750

Project: 4204 - Meadow Green ES
12025 Grovedale Drive
Whittier, 90604

Potential Change Order #CO #2: Replace MSB per RFI 002 and RFI 006

TO:	Lowell Joint School District 11537 Grovedale Dr. Whittier, California 90604	FROM:	Erickson-Hall Construction Co 500 Corporate Drive Escondido, California 92029
PCO NUMBER/REVISION:	CO #2 / 0	CONTRACT:	4204 - Meadow Green ES Prime Contract
REFERENCE:		SUBMITTED DATE:	
CHANGE TYPE:		SCHEDULE IMPACT:	

POTENTIAL CHANGE ORDER TITLE: Replace MSB per RFI 002 and RFI 006

POTENTIAL CHANGE ORDER DESCRIPTION:

Replace MSB per RFI 002 and RFI 006

The following pricing is for replacing the existing main switchboard and installing a new Eaton switchboard per the response of RFI 002 and RFI 006. Included in the cost is the credit for the two breakers per E002, the demolition of the existing gear and the installation of the new switchboard. Excluded in the cost is the coordination with Southern California Edison and any changes associated with their design.

ATTACHMENTS:

4204 - Change Order #02 - Replace MSB per RFI 002 and RFI 006.pdf

#	Cost Code	Description	Type	Amount
1	4204-01 - Electrical & FA	Furnish all labor and material to remove and replace a new switchboard per RFI 002 and RFI 006.	Commitment	\$67,596.00
2	100-00 - General Conditions	Contractor OH&P (5%)	Other	\$3,380.00
3	100-00 - General Conditions	Contractor Bond (1%)	Other	\$710.00
			Grand Total:	\$71,686.00

Ghataode Bannon Architects
760 W 16th Street Unit B
Costa Mesa, California 92627

Lowell Joint School District
11537 Grovedale Dr.
Whittier, California 90604

Erickson-Hall Construction Co
500 Corporate Drive
Escondido, California 92029

SIGNATURE

DATE

SIGNATURE

DATE

SIGNATURE

DATE



ERICKSON - HALL
CONSTRUCTION CO.

Change Order Proposal

School: Meadow Green Elementary School

Project Name: Meadow Green Elementary School - HVAC and REROOF
Project No.: 4204

DSA Application No.: 03-121823

Architect: Ghataode Bannon Architects.
Project Manager: Lowell Joint School District
Contractor: Erickson-Hall Construction Co.

COP No.: 2
Date: 7/21/2022
Reference RFIs: RFI 002 and 006
Reference RFP / Bulletin No.: N/A

DESCRIPTION: The following pricing is for replacing the existing main switchboard and installing a new Eaton switchboard per the response of RFI 002 and RFI 006. Included in the cost is the credit for the two breakers per E002, the demolition of the existing gear and the installation of the new switchboard. Excluded in the cost is the coordination with Southern California Edison and any changes associated with their design.

Subcontractor Costs (used when work is subcontracted)

Subcontractor	Description	Material	Labor	Equipment	Totals
Champion Electric, Inc.	Replace Existing Main Switchboard with New	\$ 50,688.45	\$ 9,004.72	\$ 1,150.00	\$ 60,843.17
					\$ -
					\$ -
					\$ -
					\$ -
	Subtotals	\$ 50,688.45	\$ 9,004.72	\$ 1,150.00	\$ 60,843.17
	Subcontractor OH and Profit (10%)				\$ 6,084.32
	Tired Subcontractor Cost				N/A
	Subcontractor Profit of Tired Subcontractor (5%)				N/A
	Subcontractor Bond (1%)				\$ 669.27
	Subcontractor Subtotal				\$ 67,596.76
	Contractor OH and Profit (5%)				\$ 3,379.84
	Contractor/Subcontractor Subtotal				\$ 70,976.60
	Contractor Bond (1%)				\$ 709.77
	Subcontractor Total + Contractor Mark-ups				\$ 71,686.37

Contractor Costs (used when work is self-performed)

Contractor	Description	Material	Labor	Equipment	Totals
					\$ -
					\$ -
					\$ -
	Subtotals	\$ -	\$ -	\$ -	\$ -
	Contractor OH and Profit (10%)				\$ -
	Contractor totals				\$ -
	Contractor Bond (1%)				\$ -
	Contractor Subtotal				\$ -

TOTAL COSTS FOR COP No. 2 \$ 71,686

Contractor Time

TOTAL TIME FOR COP No. 2 0 days

Contractor: Erickson-Hall Construction Co.
Submitted by _____

Date: _____

District Approval:
Signature _____

Date: _____



Champion Electric Inc.

3950 Garner Rd.
Riverside, CA 92501
Telephone: (951)-591-5374
Contact: Roger Hernandez
E-mail: Rhernandez@championelec.com

Erickson-Hall Construction Co.

500 Corporate Drive
Escondido, CA 92029
Telephone: 760-803-0077
Contact: Mike Arnold
E-mail: marnold@ericksonhall.com

COST PROPOSAL

CCN # PCO 004 - REPLACE MSB R1
Date: 7/7/2022
Project Name: Meadow Green
Page Number: 1

DETAILS OF PROPOSAL

Description of Work:

Demo existing main switchboard and replace with new Eaton Pow-R-Line Xpert Switchboard 1200A. This includes a \$1,900 credit for the 2 breakers that were to be replaced per the drawings.

This price is contingent on being able to reuse the existing conductors and any conduit going into the existing gear. If any conductors do not reach the new breakers, new conductors or splicing would be required.

This does not include any work or material that Edison may require.

Conditions:

Upon review of the above stated direction we have identified cost impacts that must be addressed. We are submitting this proposal for your acceptance in response to this direction. This proposal is valid for a period of ten (10) business days upon receipt. As part of this proposal a time extension of ten (10) working days are required to be added to our contract to mitigate impacts to the original contract schedule. If a time extension is not acceptable we reserve the right to void this proposal and resubmit a new cost that accounts for acceleration, trade stacking, delays and other issues as may be required. This proposal is based upon information provided by the owner to accomplish completion of this change and we accept no responsibility for inadequate engineering or incomplete information. Excluded from this quote is any demo, patching, repairing, and or painting of finished surfaces unless specifically stated otherwise. We reserve the right to re-evaluate this pricing if conditions or information changes from time of submission to notice to proceed. Upon acceptance of this proposal please expedite our notice to proceed so work may begin as soon as possible. Please contact the undersigned if there are any questions in regards to this proposal.

PROPOSAL TOTAL

\$67,596.00

Signature: _____

CCN # PCO 004 - REPLACE MSB R1
 Date: 7/7/2022
 Project Name: Meadow Green
 Page Number: 2

ITEMIZED BREAKDOWN

Description	Qty	Labor	Total Mat.	Total Hrs.
5/8x3 1/2" WEDGE ANCHO	16	25.00	25.92	4.00
1200A 4-SECT SERVICE S	1	40.00	0.00	40.00
DEMO SWITCHGEAR	1	40.00	0.00	40.00
Totals			25.92	84.00

SUMMARY

GENERAL MATERIALS		25.92
DISTRIBUTION		45,950.00
MATERIAL TAX (@ 10.250 %)		4,712.53
TOTAL MATERIAL		50,688.45
JOURNEYMAN (35.00 Hrs @ \$98.24)		3,438.40
FOREMAN (54.00 Hrs @ \$103.08)		5,566.32
TOTAL LABOR		9,004.72
FORKLIFT (per Day)		1,150.00
TOTAL EQUIPMENT		1,150.00
MARKUP (@ 10.000 %)		6,084.32
TOTAL MARKUP		6,084.32
SUB-TOTAL		66,927.49
Warranty 1% of Labor and Material		669.27
FINAL ADJUSTMENT (@ 1.000 %)		-0.76
FINAL AMOUNT		\$67,596.00

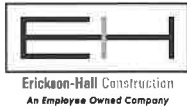

REQUEST FOR INFORMATION

Erickson-Hall Construction Co.
500 Corporate Drive
Escondido, California 92029
Phone: (760) 796-7700
Fax: (760) 796-7750

Project: 4204 - Meadow Green ES
12025 Grovedale Drive
Whittier, 90604

HIGH PRIORITY

Panel Clarification

TO:	David Bannon (Ghataode Bannon Architects)	FROM:	Jourdan Thomas (Champion Electric Inc) 3950 Garner Road Riverside, California 92501
DATE INITIATED:	06/08/2022	STATUS:	Open
LOCATION:		DUE DATE:	06/15/2022
COST IMPACT:	TBD	SCHEDULE IMPACT:	TBD
DRAWING NUMBER:	E002, E002A	SPEC SECTION:	
LINKED DRAWINGS:		REFERENCE:	Gear Submittal (noted R&R); EHCC-2
RECEIVED FROM:	Jourdan Thomas (Champion Electric Inc)		

COPIES TO:

Mike Arnold (Erickson-Hall Construction Co), Kevin Cenicerros (Erickson-Hall Construction Co), Gissell Gonzalez (Ghataode Bannon Architects), Bob Lathrop Jr. (Erickson-Hall Construction Co), Ben Regalado (Ghataode Bannon Architects)

Question from Jourdan Thomas (Champion Electric Inc) at 10:13 AM on 06/08/2022

Pertaining to the previous Gear Submittal, a few panels require clarification. Panels LD and LE have different notes on new single sheet E002A, in contrast to original single line E002. Are these panels still to be replaced? Please advise.

In addition, panel PD5 has the same note of "Replace" on both single line sheets. However, sheet E002 also includes additional notes, "Provide circuit breaker and hardware" and Existing Main Service Gear to be Reused". Do changes need to be provided for panel PD5? Or does the information in the initial submittal suffice?

*Note: The comments from the initial submittal do not mention the above noted panels.

Attachments:

[RFI #6.pdf](#)

Awaiting an Official Response

All Replies:

Intent is to replace LD, LE, and PD5.
Replacement panels need to contain branch circuit breakers to match existing respective panels.
Provide changes as indicated within the "delta 1" clouded areas of attached Sheet E002A.

SZ / FBA Engineering 6-16-2022

SHOP DRAWING REVIEW COMMENTS

PROJECT: Meadow Green Elementary School
Lowell Joint School District
FBA #107512

SUBMITTAL: Submittal 26 06 25-1.0
Specification Section #260625
Distribution Switchboards

- I. *Review of CONTRACTOR'S submittals is for general conformance with the design concept of the project and general compliance with the information given in the Contract Documents. Any action shown is subject to the requirements of the Plans and Specifications. CONTRACTOR is responsible for quantities; dimensions which shall be confirmed and correlated at the job site; fabrication processes and techniques of construction; coordination of work with that of all other trades and satisfactory performance of their work.*

REVIEW COMMENTS:

1. Distribution Panel DB1:
 - a. Change main circuit breaker and bus rating to 1000amp.
 - b. Change five 200 amp feeder circuit breakers to 250 amp.
2. Panel A:
 - a. Change bussing to 400 amp.
 - b. Change main circuit breaker to 250 amp.
 - c. Change 30A-3P branch circuit breaker at positions 37, 39, 41 to 40A-3P for service to HVAC unit AC-B8.
3. Panel B:
 - a. Change bussing to 400 amp.
 - b. Change main circuit breaker to 250 amp.
 - c. Change 30A-3P branch circuit breaker at positions 37, 39, 41 to 40A-3P for service to HVAC unit AC-B7.
4. Panel C:
 - a. Change bussing to 400 amp.
 - b. Change main circuit breaker to 250 amp.
5. Panel D:
 - a. Change bussing to 400 amp.
 - b. Change main circuit breaker to 250 amp.
 - c. Change 45A-3P branch circuit breaker at positions 1, 3, 5 to 50A-3P for service to HVAC unit AC-D1.
 - d. Change 45A-3P branch circuit breaker at positions 7, 9, 11 to 50A-3P for service to HVAC unit AC-D2.
 - e. Change 30A-3P branch circuit breaker at positions 19, 21, 23 to 40A-3P for service to HVAC unit AC-D4.
 - f. Change 30A-3P branch circuit breaker at positions 25, 27, 29 to 40A-3P for service to HVAC unit AC-D5.
 - g. Add 70A-3P branch circuit breaker (for backfeed connection to existing Panel LD per forthcoming change order)..

1075/012

6. Panel E:
- a. Change 30A-3P branch circuit breaker at positions 7, 9, 11 to 40A-3P for service to HVAC unit AC-E2.
 - b. Change 35A-3P branch circuit breaker at positions 20, 22, 24 to 40A-3P for service to HVAC unit AC-A1.
 - c. Delete 125A-3P circuit breaker serving Panel LK.
 - d. Delete 200A main circuit breaker and instead provide main lugs only.
 - e. Change all branch circuit breakers to type that is series rated with upstream feeder breaker for 42KAIC. (Upstream circuit breaker is in main switchboard and is part of forthcoming change order to replace main switchboard).
7. Amp ratings of safety switches shall be as required to accommodate fuse sizes indicated on nameplate of respective HVAC unit served.

--- End of Comments ---

CONTRACTOR ACTION:

- | | |
|---|--|
| <input type="checkbox"/> NO EXCEPTION TAKEN | <input checked="" type="checkbox"/> SEE COMMENTS ABOVE |
| <input type="checkbox"/> MAKE CORRECTIONS NOTED | <input type="checkbox"/> |
| <input type="checkbox"/> RESUBMITTAL NOT REQUIRED | <input checked="" type="checkbox"/> REVISE AND RESUBMIT AS NOTED |

**FBA Engineering
Consulting Electrical Engineers**

By: Stephen Zajicek PE **Date:** May 25, 2022



REQUEST FOR INFORMATION

Erickson-Hall Construction Co.
500 Corporate Drive
Escondido, California 92029
Phone: (760) 796-7700
Fax: (760) 796-7750

Project: 4204 - Meadow Green ES
12025 Grovedale Drive
Whittier, 90604

Circuit Breakers Loads

TO:	David Bannon (Ghataode Bannon Architects)	FROM:	Christian Mejia (Erickson-Hall Construction Co) 500 Corporate Drive Escondido, California 92029
DATE INITIATED:	05/12/2022	STATUS:	Open
LOCATION:		DUE DATE:	05/19/2022
COST IMPACT:	TBD	SCHEDULE IMPACT:	TBD
DRAWING NUMBER:	E002, E002	SPEC SECTION:	26 00 00 - GENERAL ELECTRICAL SPECIFICATIONS
LINKED DRAWINGS:		REFERENCE:	
RECEIVED FROM:	Mike Arnold (Erickson-Hall Construction Co)		
COPIES TO:	Mike Arnold (Erickson-Hall Construction Co), Kevin Cenicerros (Erickson-Hall Construction Co), Gissell Gonzalez (Ghataode Bannon Architects), Bob Lathrop Jr. (Erickson-Hall Construction Co), Ben Regalado (Ghataode Bannon Architects)		

Question from Christian Mejia (Erickson-Hall Construction Co) at 07:05 AM on 05/12/2022

Please confirm that the breakers size and wires gauge size are capable to carry the load for the HVAC units for Buildings A-B, C, D and E.

Attachments:
[RFI #002.pdf](#)

Awaiting an Official Response

All Replies:

Please refer to shop drawing review comments for 26 06 25-1 Distribution Switchboards dated 5/25/2022 and revised single-line diagram scheduled to be issued 5/31/2022.

D.Bannon
5/27/2022

SHOP DRAWING REVIEW COMMENTS

PROJECT: Meadow Green Elementary School
Lowell Joint School District
FBA #107512

SUBMITTAL: Submittal 26 06 25-1.0
Specification Section #260625
Distribution Switchboards

- i. *Review of CONTRACTOR'S submittals is for general conformance with the design concept of the project and general compliance with the information given in the Contract Documents. Any action shown is subject to the requirements of the Plans and Specifications. CONTRACTOR is responsible for quantities; dimensions which shall be confirmed and correlated at the job site; fabrication processes and techniques of construction; coordination of work with that of all other trades and satisfactory performance of their work.*

REVIEW COMMENTS:

1. Distribution Panel DB1:
 - a. Change main circuit breaker and bus rating to 1000amp.
 - b. Change five 200 amp feeder circuit breakers to 250 amp.
2. Panel A:
 - a. Change bussing to 400 amp.
 - b. Change main circuit breaker to 250 amp.
 - c. Change 30A-3P branch circuit breaker at positions 37, 39, 41 to 40A-3P for service to HVAC unit AC-B8.
3. Panel B:
 - a. Change bussing to 400 amp.
 - b. Change main circuit breaker to 250 amp.
 - c. Change 30A-3P branch circuit breaker at positions 37, 39, 41 to 40A-3P for service to HVAC unit AC-B7.
4. Panel C:
 - a. Change bussing to 400 amp.
 - b. Change main circuit breaker to 250 amp.
5. Panel D:
 - a. Change bussing to 400 amp.
 - b. Change main circuit breaker to 250 amp.
 - c. Change 45A-3P branch circuit breaker at positions 1, 3, 5 to 50A-3P for service to HVAC unit AC-D1.
 - d. Change 45A-3P branch circuit breaker at positions 7, 9, 11 to 50A-3P for service to HVAC unit AC-D2.
 - e. Change 30A-3P branch circuit breaker at positions 19, 21, 23 to 40A-3P for service to HVAC unit AC-D4.
 - f. Change 30A-3P branch circuit breaker at positions 25, 27, 29 to 40A-3P for service to HVAC unit AC-D5.
 - g. Add 70A-3P branch circuit breaker (for backfeed connection to existing Panel LD per forthcoming change order)..

1075/012

6. Panel E:
- a. Change 30A-3P branch circuit breaker at positions 7, 9, 11 to 40A-3P for service to HVAC unit AC-E2.
 - b. Change 35A-3P branch circuit breaker at positions 20, 22, 24 to 40A-3P for service to HVAC unit AC-A1.
 - c. Delete 125A-3P circuit breaker serving Panel LK.
 - d. Delete 200A main circuit breaker and instead provide main lugs only.
 - e. Change all branch circuit breakers to type that is series rated with upstream feeder breaker for 42KAIC. (Upstream circuit breaker is in main switchboard and is part of forthcoming change order to replace main switchboard).
7. Amp ratings of safety switches shall be as required to accommodate fuse sizes indicated on nameplate of respective HVAC unit served.

--- End of Comments ---

CONTRACTOR ACTION:

- | | |
|---|--|
| <input type="checkbox"/> NO EXCEPTION TAKEN | <input checked="" type="checkbox"/> SEE COMMENTS ABOVE |
| <input type="checkbox"/> MAKE CORRECTIONS NOTED | <input type="checkbox"/> |
| <input type="checkbox"/> RESUBMITTAL NOT REQUIRED | <input checked="" type="checkbox"/> REVISE AND RESUBMIT AS NOTED |

**FBA Engineering
Consulting Electrical Engineers**

By: Stephen Zajicek PE **Date:** May 25, 2022

REVISIONS

1	ISSUED FOR PERMITS
2	ISSUED FOR PERMITS
3	ISSUED FOR PERMITS
4	ISSUED FOR PERMITS
5	ISSUED FOR PERMITS
6	ISSUED FOR PERMITS
7	ISSUED FOR PERMITS
8	ISSUED FOR PERMITS
9	ISSUED FOR PERMITS
10	ISSUED FOR PERMITS

MEADOW GREEN ELEMENTARY SCHOOL
 HVAC & ROOF UPGRADES
 1205 GROVEDALE DR., WHITTIER, CA 90604
 LOWELL JOINT SCHOOL DISTRICT



BBA GARRHOAD BRANNON ARCHITECTS
 Architects - Planning - Interior Design
 121 W. 10TH STREET, SUITE 200
 COSTA MESA, CA 92626
 TEL: 714.440.8877

SINGLE LINE NOTES

1. PROVIDE ALL HOME RUN TO LOAD.

2. PROVIDE CIRCUIT BREAKER AND FUSE.

3. EXISTING MAIN SERVICE CABLE TO BE RELOCATED.

4. EXISTING CIRCUIT BREAKER AND FUSE.

5. EXISTING PANEL TO BE REPLACED WITH NEW, RECOMMEND.

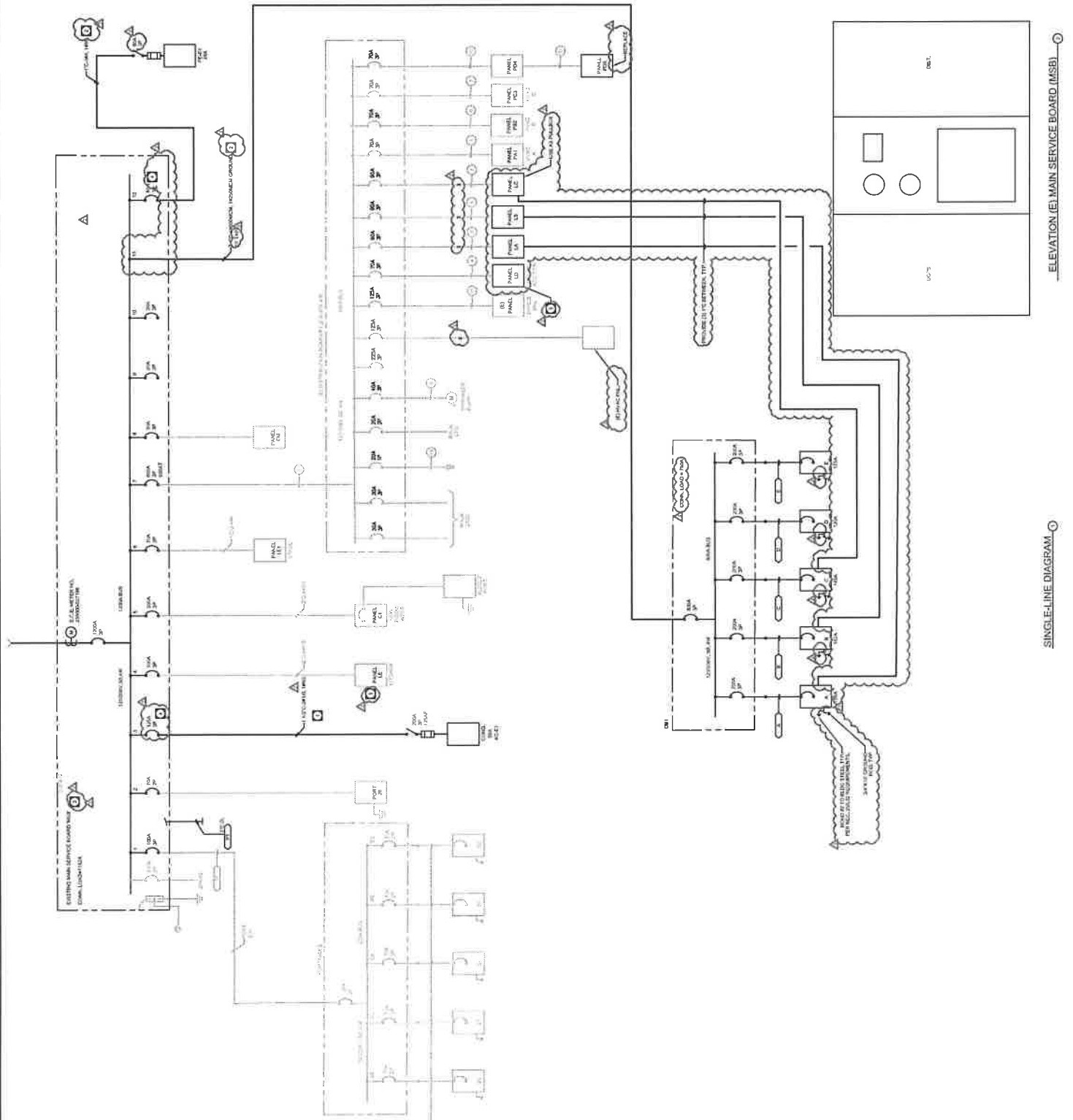

- EXISTING FEEDER SCHEDULE
- 1. 2-2-2-48 THRU
 - 2. PC-1000
 - 3. PC-1000
 - 4. PC-1000
 - 5. PC-1000
 - 6. PC-1000
 - 7. PC-1000
 - 8. PC-1000
 - 9. PC-1000
 - 10. PC-1000
 - 11. PC-1000
 - 12. PC-1000
 - 13. PC-1000
 - 14. PC-1000
 - 15. PC-1000
 - 16. PC-1000
 - 17. PC-1000
 - 18. PC-1000
 - 19. PC-1000
 - 20. PC-1000

ELEVATION (E) MAIN SERVICE BOARD (MSB)

SINGLE-LINE DIAGRAM

REVISIONS

1. RECONNECT AND REMOVE EXISTING LOADS UNCHANGED AND PANELS FROM MAIN METER SECTION OF SWITCHBOARD.
2. MAIN METER SECTION OF SWITCHBOARD.
3. RECONNECT AND REMOVE EXISTING LOADS UNCHANGED AND PANELS FROM MAIN METER SECTION OF SWITCHBOARD.
4. CHANGE SCHEMATIC OF SWITCHBOARD TO REFLECT CHANGES TO EXISTING AND REMOVED LOADS AND TERMINATION OF EXISTING PANELS TO NEW MAIN METER SECTION.
5. COORDINATE WITH CITY CONTRACTOR TO RECONNECT EXISTING SERVICE TO NEW MAIN METER SECTION.
6. VERIFY EXISTING SERVICE PANELS TO REMAIN ON EXISTING MAIN METER SECTION AND VERIFY ALL EXISTING AND REMOVED LOADS TO NEW MAIN METER SECTION.
7. VERIFY EXISTING SERVICE PANELS TO REMAIN ON EXISTING MAIN METER SECTION AND VERIFY ALL EXISTING AND REMOVED LOADS TO NEW MAIN METER SECTION.
8. RECONNECT EXISTING FEEDER CIRCUITS FROM EXISTING MAIN METER SECTION AND RECONNECT TO NEW MAIN METER SECTION.
9. PROVIDE TERMINATION FACILITIES FOR FEEDER LEAVING MAIN METER SECTION MAINS SAME ROOM.
10. RECONNECT AND REMOVE EXISTING FEEDER CIRCUITS FROM EXISTING MAIN METER SECTION TO NEW MAIN METER SECTION.
11. REMOVE EXISTING FEEDER CIRCUITS FROM EXISTING MAIN METER SECTION TO NEW MAIN METER SECTION.
12. VERIFY EXISTING SERVICE PANELS TO REMAIN ON EXISTING MAIN METER SECTION AND VERIFY ALL EXISTING AND REMOVED LOADS TO NEW MAIN METER SECTION.
13. VERIFY EXISTING SERVICE PANELS TO REMAIN ON EXISTING MAIN METER SECTION AND VERIFY ALL EXISTING AND REMOVED LOADS TO NEW MAIN METER SECTION.
14. RECONNECT AND REMOVE EXISTING FEEDER CIRCUITS FROM EXISTING MAIN METER SECTION TO NEW MAIN METER SECTION.
15. RECONNECT AND REMOVE EXISTING FEEDER CIRCUITS FROM EXISTING MAIN METER SECTION TO NEW MAIN METER SECTION.
16. RECONNECT AND REMOVE EXISTING FEEDER CIRCUITS FROM EXISTING MAIN METER SECTION TO NEW MAIN METER SECTION.
17. RECONNECT AND REMOVE EXISTING FEEDER CIRCUITS FROM EXISTING MAIN METER SECTION TO NEW MAIN METER SECTION.
18. RECONNECT AND REMOVE EXISTING FEEDER CIRCUITS FROM EXISTING MAIN METER SECTION TO NEW MAIN METER SECTION.
19. RECONNECT AND REMOVE EXISTING FEEDER CIRCUITS FROM EXISTING MAIN METER SECTION TO NEW MAIN METER SECTION.
20. RECONNECT AND REMOVE EXISTING FEEDER CIRCUITS FROM EXISTING MAIN METER SECTION TO NEW MAIN METER SECTION.
21. RECONNECT AND REMOVE EXISTING FEEDER CIRCUITS FROM EXISTING MAIN METER SECTION TO NEW MAIN METER SECTION.
22. RECONNECT AND REMOVE EXISTING FEEDER CIRCUITS FROM EXISTING MAIN METER SECTION TO NEW MAIN METER SECTION.
23. RECONNECT AND REMOVE EXISTING FEEDER CIRCUITS FROM EXISTING MAIN METER SECTION TO NEW MAIN METER SECTION.
24. RECONNECT AND REMOVE EXISTING FEEDER CIRCUITS FROM EXISTING MAIN METER SECTION TO NEW MAIN METER SECTION.
25. RECONNECT AND REMOVE EXISTING FEEDER CIRCUITS FROM EXISTING MAIN METER SECTION TO NEW MAIN METER SECTION.
26. RECONNECT AND REMOVE EXISTING FEEDER CIRCUITS FROM EXISTING MAIN METER SECTION TO NEW MAIN METER SECTION.
27. RECONNECT AND REMOVE EXISTING FEEDER CIRCUITS FROM EXISTING MAIN METER SECTION TO NEW MAIN METER SECTION.

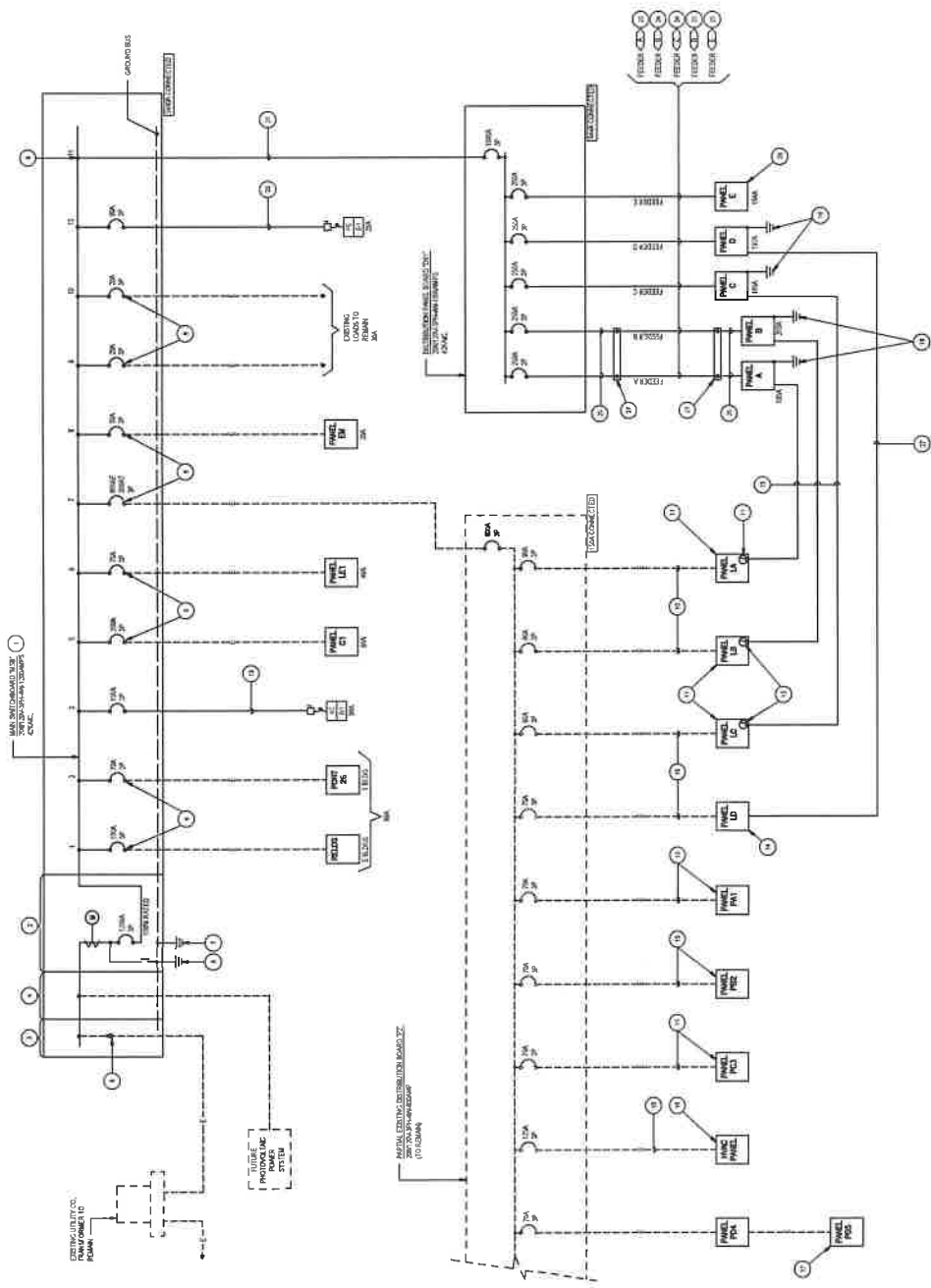

LOAD SUMMARY

1	2000 VA
2	2000 VA
3	2000 VA
4	2000 VA
5	2000 VA
6	2000 VA
7	2000 VA
8	2000 VA
9	2000 VA
10	2000 VA
11	2000 VA
12	2000 VA
13	2000 VA
14	2000 VA
15	2000 VA
16	2000 VA
17	2000 VA
18	2000 VA
19	2000 VA
20	2000 VA
21	2000 VA
22	2000 VA
23	2000 VA
24	2000 VA
25	2000 VA
26	2000 VA
27	2000 VA

THIS DRAWING IS THE PROPERTY OF PEBA ENGINEERING. IT IS TO BE USED ONLY FOR THE PROJECT AND SITE SPECIFICALLY IDENTIFIED.

LOWELL JOINT SCHOOL DISTRICT
August 8, 2022

To: President Salinas and Members, Board of Trustees

From: Jim Coombs, Superintendent of Schools

Subject: Approval of Change Order for Additional Professional
Services Agreement with RMA Group for Monitoring, Testing, and
Inspecting at Jordan Elementary School

ACTION/
(RATIFICATION)

Background:

On June 11, 2018, the Lowell Joint School District Board of Trustees approved Resolution 2018-19 No. 724 ordering a School Bond Election. On November 6, 2018, the voters in the Lowell Joint School District passed measure LL. A part of Measure LL includes the repairs and upgrades to District facilities. This expenditure is subject to the purview of the Citizens Bond Oversight Committee.

Current Considerations:

Unlike the Public Works competitive bidding process, Professional Service providers can be selected on the basis of their qualifications, services they provide and their value to the District.

In October, 2018, the District issued an RFQ for Materials testing and Geotechnical firms. Based on the results of the scoring, RMA Group was one of the firms selected by the District to provide geological inspection and testing services. In August, 2020 the Board of Trustees approved an agreement with RMA District requested a proposal from RMA Group for a geotechnical engineering investigation for the Jordan Elementary School modernization and Portables to Permanent Buildings Project. Subsequently, RMA Group provided the investigation and report.

In June of 2021, the Board of Trustees approved an agreement with the RMA Group to provide geological inspection and testing services at Jordan Elementary School. During the project, there were additional areas where earthwork monitoring/testing, and masonry testing were required. The increase in scope resulted in an additional fee of \$10,452. This increased the total amount of the proposal to \$126,316.

Financial Implications

Financial Impact: \$126,316.00

Superintendent's Comment:

APPROVAL RECOMMENDED.

Funding Source:

Measure LL General Obligation Fund – Fund 21.0

Recommendation:

It is recommended that the Board of Trustees ratify an additional Professional Services Agreement with RMA Group for Monitoring, Testing, and Inspecting at Jordan Elementary School, effective May 3, 2022 through May 1, 2023, not to exceed \$10,452 (21.0-00000-0-00000-85000-6282-0040000) Measure LL (21.0 Bond Fund), and that the Superintendent or designee be authorized to execute the necessary documents.

Superintendent's Comment:

APPROVAL RECOMMENDED.



Project No: 21-0851-0

June 24, 2022

Lowell Joint School District
11537 Grovedale Dr
Whittier, CA 90604

Attention: David Bennett

Subject: Change Order Proposal to complete Inspection and Testing Services
Jordan Elementary School 03-121043
10654 Jordan Rd
Whittier, CA

We have prepared this change order to request a contract modification to complete our scope on the Jordan Elementary School HVAC, Roofing, Fire Alarm & (N) Modular Buildings project. Due to additional work that will exceed RMA Group's original scope of work amount, RMA Group will need to perform the following additional work that remains on the project

SCOPE OF WORK

Our scope of work will consist of the following:

**Earthwork Monitoring and Testing
Special Inspection and Testing of Masonry**

We propose to perform these services on an hourly or test rate basis in accordance to the unit cost contained in the current active master agreement, for an additional estimated amount of \$10,452.00. This will increase the total contract from \$115,864.00 to \$126,316.00. In witness thereof, the parties have caused this agreement to be duly executed the day and year first above written.

CLIENT

By: _____

Title: _____

Date: _____

RMA Group

 _____

Prisila Neri
Title: Project Manager



ESTIMATE WORKSHEET
Compaction Testing of Trench Backfill

Item	Quantity	Unit	Unit Price	Total
Soils Engineering Technician	24	HR	\$94.50	\$2,268.00
Subtotal:				\$2,268.00

ESTIMATE WORKSHEET
Structural Steel Shop and Field Welding

Item	Quantity	Unit	Unit Price	Total
AWS Certified Welding Inspector- Field	52	HR	\$94.50	\$4,914.00
AWS Certified Welding Inspector- Shop	20	HR	\$94.50	\$1,890.00
Subtotal:				\$6,804.00

ESTIMATE WORKSHEET
Project Administration, Engineering Oversight, and Reporting

Item	Quantity	Unit	Unit Price	Total
Project Manager - Office	2	HR	\$155.00	\$310.00
Project Engineer - Office	4	HR	\$170.00	\$680.00
Administrative	2	HR	\$60.00	\$120.00
Staff Engineer - Office	2	HR	\$135.00	\$270.00
Subtotal:				\$1,380.00

LOWELL JOINT SCHOOL DISTRICT
August 8, 2022

To: President Salinas and Members, Board of Trustees

From: Jim Coombs, Superintendent of Schools

Subject: Award District-Wide Solid/Organic Waste and Recycling Services to WARE Disposal, Inc. (RFP# 202122-03) ACTION

To comply with State of California Mandatory Commercial Organics and Recycling requirements (Assembly Bills AB 1826 Solid waste: organic waste and AB 341 Solid waste: diversion) and other applicable codes and regulations to reduce volume of waste and consolidate services, District staff issued Request for Proposals (RFP) #202122-03 for district-wide solid/organic waste and recycling services. A pre-bid job-walkthrough was conducted on April 25, 2022 and two (2) contractors participated.

Proposals were due on May 4, 2022 and the District received proposals from the two (2) contractors as shown below:

- American Reclamation, Inc.
- WARE Disposal, Inc.

After review and scoring of the proposals in the categories below, it was determined that WARE Disposal, Inc. provided the best value to the District.

- Mandatory Requirements
- Firm Personnel, Capacity, Methodology
- Relevant Experience and Past Performance
- References
- Safety
- Price

It is recommended that the Board of Trustees award district-wide solid/organic waste and recycling services to WARE Disposal, Inc., and that the Superintendent or designee be authorized to execute the necessary documents.

Superintendent's Comment:

APPROVAL RECOMMENDED.

LOWELL JOINT SCHOOL DISTRICT
August 8, 2022

To: President Salinas and Members, Board of Trustees

From: Jim Coombs, Superintendent of Schools

Subject: Approval of Ratified Consultant Agreement with Debra Lees to provide support for the Lowell Sustainable Science Literacy Garden at the Maybrook Campus during 2022-2023 School Year. ACTION/
(RATIFICATION)

Arrangements have been made with Mrs. Debra Lees to provide support for the Lowell Joint Sustainable Science Literacy Garden at the Maybrook Campus for the 2022-2023 school year. Mrs. Lees will be paid a total of \$1,512.00 a month, and will not exceed \$15,120.00 for the school year. Funding for this expenditure will be covered by Title IV Student Support and Academic Enrichment Funds.

It is recommended that the ratified consultant agreement with Mrs. Debra Lees to provide support for the Lowell Joint Sustainable Science Literacy Garden at the Maybrook Campus for the 2022/2023 school year, at the not to exceed amount of \$15,120.00, to be paid from the Title IV Student Support and Academic Enrichment funds, and that the Superintendent or designee be authorized to execute the agreement.

Superintendent's Comment:

APPROVAL RECOMMENDED.

LOWELL JOINT SCHOOL DISTRICT
August 8, 2022

To: President Salinas and Members, Board of Trustees

From: Jim Coombs, Superintendent of Schools

Subject: Approval of Memorandum of Understanding With Walnut Valley Consortium Induction Program, Effective July 1, 2022 through June 30, 2023 ACTION/
(RATIFICATION)

This Memorandum of Understanding (MOU) describes how the *Walnut Valley Consortium Induction Program* (Walnut Valley Unified School District, Lead Educational Agency) will collaborate with the Lowell Joint SD to provide clear credentialing services to the administrators and teachers of Lowell Joint SD who hold a preliminary credential, either through teacher induction or the Clear Administrative Services Credential (CASC) induction program.

The intent of this MOU is to document that Lowell Joint SD is partnering with the Walnut Valley Consortium and agrees to provide resources necessary to conduct relevant activities as outlined in Section A. Lowell Joint SD will comply with the *California Commission on Teacher Credentialing* procedures and relevant regulations, and agrees to pay all associated fees as outlined in Section A.

This MOU will be effective July 1, 2022, unless terminated upon mutual consent of both parties, or through June 30, 2023, at a cost of \$3000 per qualified teacher to the district, to be paid from the General Fund/Educator Effectiveness Grant.

It is recommended the Memorandum of Understanding with Walnut Valley Consortium Induction Program, Effective July 1, 2022 through June 30, 2023, at a cost of \$3000 per qualified teacher to the district, to be paid from the General Fund/Educator Effectiveness Grant, be approved, and that the Superintendent or designee be authorized to execute the necessary documents.

Superintendent's Comment:

APPROVAL RECOMMENDED.

LOWELL JOINT SCHOOL DISTRICT
August 8, 2022

To: President Salinas and Members, Board of Trustees

From: Jim Coombs, Superintendent of Schools

Subject: Approval of Memorandum of Understanding Educational Fieldwork Agreement with University of Redlands, Effective July 1, 2022 through June 30, 2024 ACTION/
(RATIFICATION)

The purpose of this Agreement is to provide educational fieldwork experiences to students enrolled in the Professional Educational curriculum and/or the Communication Sciences and Disorders graduate curriculum of the University. This Agreement is entered into pursuant to the applicable provisions of the California Educational Code, including, but not limited to, Section 11006.

This MOU will be effective July 1, 2022, unless terminated upon mutual consent of both parties, or through June 30, 2024, at no cost to the district.

It is recommended the Memorandum of Understanding Educational Fieldwork Agreement with University of Redlands, effective July 1, 2022 through June 30, 2024 be approved, and that the Superintendent or designee be authorized to execute the necessary documents.

Superintendent's Comment:

APPROVAL RECOMMENDED.

LOWELL JOINT SCHOOL DISTRICT
August 8, 2022

To: President Salinas and Members, Board of Trustees

From: Jim Coombs, Superintendent of Schools

Subject: Approval of Consultant Agreement with Mrs. Linda Takacs to ACTION
 Serve as the Director, Lowell Joint Induction Program for the
 2022-2023 School Year

Arrangements have been made with Mrs. Linda Takacs to coordinate, lead, and provide coaching for our Lowell Joint Teacher and Administrative Induction program for the 2022-2023 school year. Mrs. Takacs' contract for an amount not to exceed \$35,000.00 for the school year. Funding for this expenditure to be paid from the General Fund/Educator Effectiveness Grant.

It is recommended that the consultant agreement with Mrs. Takacs to serve as the director of the Lowell Joint induction program for the 2022-2023 school year, not to exceed \$35,000.00, be approved, and that the Superintendent or designee be authorized to execute the necessary documents.

Superintendent's Comment:

APPROVAL RECOMMENDED.

LOWELL JOINT SCHOOL DISTRICT
August 8, 2022

To: President Salinas and Members, Board of Trustees

From: Jim Coombs, Superintendent of Schools

Subject: Purchase Order Report 2022/23 #1

ACTION/
(RATIFICATION)

In accordance with the law, Purchase Order Report 2022/23 #1 is recommended for approval.
The report lists all purchase orders issued June 01, 2022, through June 30, 2022.

AR

Attachment

Superintendent's Comment:

APPROVAL RECOMMENDED.

X-B1-1

LOWELL JOINT SD

PURCHASE ORDER DETAIL REPORT
BOARD OF TRUSTEES MEETING 08/08/2022

FROM 06/01/2022 TO 06/30/2022

<u>PO NUMBER</u>	<u>VENDOR</u>	<u>PO TOTAL</u>	<u>ACCOUNT AMOUNT</u>	<u>ACCOUNT NUMBER</u>	<u>PSEUDO / OBJECT DESCRIPTION</u>
R99A0016	OCDE	4,200.00	4,200.00	0174250056 5800	ELO#2-LG5A1 / Prof/ConsultingServ&Oper Exp
R99B0045	KING OFFICE SERVICES	16,500.00	16,500.00	2100000011 6282	BF-Unrest-Not Applicable / Consultant/Contractor
R99B0046	DIVISION OF THE STATE ARCHITECT	9,140.00	9,140.00	2100000015 6217	BF-Unrest-Not Applicable / DSA Fees
R99F0138	PDO EQUIPMENT RENTAL	330.00	330.00	0100000098 5610	GF-Unrest-Not Applicable / Rentals & Leases
R99F0139	ORBIT EVENT RENTALS	3,610.00	3,610.00	0100000094 4300	GF-Unrest-Not Applicable / Materials and Supplies
R99F0140	ICS SERVICE COMPANY	1,819.10	403.50	0100000089 5630	GF-Unrest-Not Applicable / Repairs or Maintenance
			240.00	0100000090 5630	GF-Unrest-Not Applicable / Repairs or Maintenance
			455.60	0100000091 5630	GF-Unrest-Not Applicable / Repairs or Maintenance
			240.00	0100000093 5630	GF-Unrest-Not Applicable / Repairs or Maintenance
			480.00	0100000096 5630	GF-Unrest-Not Applicable / Repairs or Maintenance
R99F0141	EAST WHITTIER GLASS & MIRROR	175.00	175.00	0100000093 5630	GF-Unrest-Not Applicable / Repairs or Maintenance
R99F0142	EAST WHITTIER GLASS & MIRROR	200.00	200.00	0100000093 5630	GF-Unrest-Not Applicable / Repairs or Maintenance
R99F0143	F.M. THOMAS AIR CONDITIONING	5,945.14	5,945.14	0100000094 5630	GF-Unrest-Not Applicable / Repairs or Maintenance
R99F0144	F.M. THOMAS AIR CONDITIONING	1,432.44	1,432.44	0100000094 5630	GF-Unrest-Not Applicable / Repairs or Maintenance
R99F0145	BUG FLIP	215.00	100.00	0100000121 5570	GF-Unrestricted / Pest Control
			60.00	0100000138 5570	GF-Unrestricted / Pest Control
			30.00	0100000141 5570	GF-Unrestricted / Pest Control
			25.00	0100000142 5570	GF-Unrestricted / Pest Control
R99F0146	CANNINGS HARDWARE LA HABRA	74.56	74.56	0100000098 4300	GF-Unrest-Not Applicable / Materials and Supplies
R99F0147	CINTAS FIRE PROTECTION	471.34	235.67	0100000092 5630	GF-Unrest-Not Applicable / Repairs or Maintenance
			235.67	0100000094 5630	GF-Unrest-Not Applicable / Repairs or Maintenance
R99F0148	GLASBY MAINTENANCE SUPPLY	20,566.66	2,893.88	0185100004 4300	RRMA-Cust/Jordan / Materials and Supplies
			4,125.15	0185100005 4300	RRMA-Cust-Macy / Materials and Supplies
			465.13	0185100007 4300	RRMA-Cust/Olita / Materials and Supplies
			7,132.14	0185100008 4300	RRMA-Cust/RS / Materials and Supplies
			4,515.82	0185100022 4300	RRMA-Custodial/Maybrook / Materials and Supplies

LOWELL JOINT SD

PURCHASE ORDER DETAIL REPORT
BOARD OF TRUSTEES MEETING 08/08/2022

FROM 06/01/2022 TO 06/30/2022

PO NUMBER	VENDOR	PO TOTAL	ACCOUNT AMOUNT	ACCOUNT NUMBER	PSEUDO / OBJECT DESCRIPTION
R99F0148	*** CONTINUED ***		1,434.54	1851000003 4300	RRMA-Cust/EP / Materials and Supplies
R99F0149	F.M. THOMAS AIR CONDITIONING	4,142.49	4,142.49	0100000094 5630	GF-Unrest-Not Applicable / Repairs or Maintenance
R99F0150	AMERICAN TIME	218.99	218.99	0100000098 4300	GF-Unrest-Not Applicable / Materials and Supplies
R99F0151	BUG FLIP	120.00	90.00	0100000105 5570	GF-Unrest-Not Applicable / Pest Control
			30.00	0100000106 5570	GF-Unrest-Not Applicable / Pest Control
R99F0152	THE SHERWIN-WILLIAMS CO.	1,001.37	1,001.37	0100000098 4300	GF-Unrest-Not Applicable / Materials and Supplies
R99F0153	THE SHERWIN-WILLIAMS CO.	10,771.42	10,771.42	4000000027 6400	CapAssst/Fac&Ops / Equipment
R99F0154	SOUTHEAST CONSTRUCTION PRODUCT	40.68	18.25	0100000090 4300	GF-Unrest-Not Applicable / Materials and Supplies
			22.43	0100000098 4300	GF-Unrest-Not Applicable / Materials and Supplies
R99F0155	LOWES	16.44	16.44	0100000095 4300	GF-Unrest-Not Applicable / Materials and Supplies
R99F0156	CITY OF LA HABRA	2,865.51	2,048.93	0100000098 4360	GF-Unrest-Not Applicable / Tires, Fuel and Oil
			816.58	0100000108 4360	GF-Unrest-Not Applicable / Tires, Fuel and Oil
R99F0157	THE HOME DEPOT PRO INSTITUTION	2,972.03	64.66	0100000090 4300	GF-Unrest-Not Applicable / Materials and Supplies
			1,043.83	0100000094 4300	GF-Unrest-Not Applicable / Materials and Supplies
			1,863.54	0100000098 4300	GF-Unrest-Not Applicable / Materials and Supplies
R99F0158	WALTERS WHOLESALE ELECTRIC	2,634.91	100.85	0100000093 4300	GF-Unrest-Not Applicable / Materials and Supplies
			2,534.06	0100000098 4300	GF-Unrest-Not Applicable / Materials and Supplies
R99M0250	AMERICAN EXPRESS	457.46	457.46	0108880020 4300	GF-Technology-Not Applicable / Materials and Supplies
R99M0254	AMERICAN EXPRESS	189.63	189.63	0105110043 4300	ClsAdminRS-LCAP G1/A8 / Materials and Supplies
R99M0255	AMERICAN EXPRESS	429.92	429.92	010880006 4300	GF-TechAllocMG / Materials and Supplies
R99M0256	AMERICAN EXPRESS	2,841.60	2,841.60	0140350029 5200	TII-EdServ-G4A1 / Travel and Conferences
R99M0257	AMERICAN EXPRESS	94,798.84	94,798.84	0163000002 4130	GF-Lottery-Not Applicable / Textbooks
R99M0258	AMERICAN EXPRESS	120.00	120.00	0140350029 5200	TII-EdServ-G4A1 / Travel and Conferences

LOWELL JOINT SD

PURCHASE ORDER DETAIL REPORT
BOARD OF TRUSTEES MEETING 08/08/2022

FROM 06/01/2022 TO 06/30/2022

PO NUMBER	VENDOR	PO TOTAL	ACCOUNT AMOUNT	ACCOUNT NUMBER	PSEUDO / OBJECT DESCRIPTION
R99R0473	FULLERTON JOINT UNION HS DIST	1,161.00	1,161.00	250000014 5800	DM-Unrest-NotApplic / Prof/ConsultingServ&Oper Exp
R99R0474	LUX BUS AMERICA	1,000.00	1,000.00	0105110036 4300	GF-SiteAllocRS-LCAPGL1-Act8 / Materials and Supplies
R99R0475	COLLEGE BOARD	2,091.00	2,091.00	0105110043 4300	ClsAdmRS-LCAP G1/A8 / Materials and Supplies
R99R0476	BUENA PARK PLAQUE & TROPHY	80.81	80.81	0100000317 4300	GF_UNRESTRICTED_SUPPT / Materials and Supplies
R99R0477	PARENTPOWERED PBC	1,745.00	1,745.00	0190200006 5810	EarlyLit/L-G2A4 / Licenses/Technology
R99R0478	WALTERS WHOLESALE ELECTRIC	2,493.04	2,336.46	0100000098 4300	GF-Unrest-Not Applicable / Materials and Supplies
			156.58	0100000098 4380	GF-Unrest-Not Applicable / Tools/M&O
R99R0479	HEAR NOW	407.93	407.93	016500063 5850	GF-SPECIAL ED / Const/Insd Contractors(NonEmp)
R99R0480	TRINIDAD, GINA	617.58	617.58	0105110043 4300	ClsAdmRS-LCAP G1/A8 / Materials and Supplies
R99R0481	GLASBY MAINTENANCE SUPPLY	14,038.17	3,102.96	0185100004 4300	RRMA-Cust/Jordan / Materials and Supplies
			2,396.39	0185100005 4300	RRMA-Cust/Macy / Materials and Supplies
			1,315.93	0185100006 4300	RRMA-Cust/MG / Materials and Supplies
			869.09	0185100007 4300	RRMA-Cust/Olita / Materials and Supplies
			900.69	0185100008 4300	RRMA-Cust/RS / Materials and Supplies
			3,588.70	0185100009 4300	RRMA-Cust/D.O. / Materials and Supplies
			670.49	0185100022 4300	RRMA-Custodial/Maybrook / Materials and Supplies
			1,193.92	1851000003 4300	RRMA-Cust/EP / Materials and Supplies
R99R0482	SPORTS JACKETS UNLIMITED	460.85	460.85	0100000317 4300	GF_UNRESTRICTED_SUPPT / Materials and Supplies
R99R0483	J.W.PEPPER & SON INC.	280.01	280.01	0105110036 4300	GF-SiteAllocRS-LCAPGL1-Act8 / Materials and Supplies
R99R0484	LA HABRA AREA CHAMBER OF COMME	150.00	150.00	0100000317 4300	GF_UNRESTRICTED_SUPPT / Materials and Supplies
R99R0485	IMPERIAL BAND INSTRUMENTS	686.32	176.32	0105110041 4300	GF-SiteAllocRS / Materials and Supplies
			510.00	0105110041 5630	GF-SiteAllocRS / Repairs or Maintenance
R99R0486	IMPERIAL BAND INSTRUMENTS	165.49	65.49	0105110041 4300	GF-SiteAllocRS / Materials and Supplies
			100.00	0105110041 5630	GF-SiteAllocRS / Repairs or Maintenance
R99R0487	INLAND EMPIRE TRAILERS	4,340.00	4,340.00	0100000108 4400	GF-Unrest-Not Applicable / Non Capitalized Equipment

LOWELL JOINT SD

PURCHASE ORDER DETAIL REPORT

BOARD OF TRUSTEES MEETING 08/08/2022

FROM 06/01/2022 TO 06/30/2022

PO NUMBER	VENDOR	PO TOTAL	ACCOUNT AMOUNT	ACCOUNT NUMBER	PSEUDO / OBJECT DESCRIPTION
R99R0488	SAVVAS LEARNING COMPANY LLC	246,557.30	246,557.30	0163000002 4130	GF-Lottery-Not Applicable / Textbooks
R99R0489	RANCHERS IRRIGATION SUPPLY	281.69	261.55	0100000094 4300	GF-Unrest-Not Applicable / Materials and Supplies
			20.14	0100000095 4300	GF-Unrest-Not Applicable / Materials and Supplies
R99R0490	LOWES	271.30	271.30	0100000094 4300	GF-Unrest-Not Applicable / Materials and Supplies
R99R0491	TRINIDAD, GINA	1,488.38	1,488.38	0105110043 4300	ClsAdmnRS-LCAP G1/A8 / Materials and Supplies
R99R0492	BUG FLIP	1,280.00	165.00	0100000117 5570	GF-Unrestricted / Pest Control
			265.00	0100000121 5570	GF-Unrestricted / Pest Control
			165.00	0100000137 5570	GF-Unrestricted / Pest Control
			165.00	0100000138 5570	GF-Unrestricted / Pest Control
			165.00	0100000141 5570	GF-Unrestricted / Pest Control
			355.00	0100000142 5570	GF-Unrestricted / Pest Control
R99R0493	IMPERIAL SPRINKLER SUPPLY	3,714.31	3,714.31	0100000108 4300	GF-Unrest-Not Applicable / Materials and Supplies
R99R0494	DANGELO COMPANY	38.87	38.87	0100000098 4300	GF-Unrest-Not Applicable / Materials and Supplies
R99R0495	UNITED REFRIGERATION INC.	3,421.96	3,421.96	0100000098 4300	GF-Unrest-Not Applicable / Materials and Supplies
R99R0496	UNITED REFRIGERATION INC.	3,408.07	698.62	0100000094 4300	GF-Unrest-Not Applicable / Materials and Supplies
			2,709.45	0100000098 4300	GF-Unrest-Not Applicable / Materials and Supplies
R99R0497	IMPERIAL BAND INSTRUMENTS	23.14	23.14	0105110036 4300	GF-SiteAllocRS-LCAPGL1-Act8 / Materials and Supplies
R99R0498	THE SHERWIN-WILLIAMS CO.	505.99	59.04	0100000092 4300	GF-Unrest-Not Applicable / Materials and Supplies
			118.08	0100000093 4300	GF-Unrest-Not Applicable / Materials and Supplies
			275.92	0100000094 4300	GF-Unrest-Not Applicable / Materials and Supplies
			52.95	0100000098 4300	GF-Unrest-Not Applicable / Materials and Supplies
R99R0499	CASBO	3,500.00	3,500.00	0100000071 5300	GF-Unrest-Not Applicable / Dues and Memberships
R99R0500	GARDENA VALLEY PRINTING	327.00	327.00	0105110044 4300	GF-SiteAlloc RS / Materials and Supplies
R99R0501	ICS SERVICE COMPANY	379.10	163.50	0100000089 5630	GF-Unrest-Not Applicable / Repairs or Maintenance
			215.60	0100000093 5630	GF-Unrest-Not Applicable / Repairs or Maintenance

LOWELL JOINT SD

PURCHASE ORDER DETAIL REPORT
BOARD OF TRUSTEES MEETING 08/08/2022

FROM 06/01/2022 TO 06/30/2022

PO NUMBER	VENDOR	PO TOTAL	ACCOUNT AMOUNT	ACCOUNT NUMBER	PSEUDO / OBJECT DESCRIPTION
R99R0502	PLUMBING WHOLESALE OUTLET	625.67	29.12	0100000092 4300	GF-Unrest-Not Applicable / Materials and Supplies
			255.20	0100000093 4300	GF-Unrest-Not Applicable / Materials and Supplies
			341.35	0100000098 4300	GF-Unrest-Not Applicable / Materials and Supplies
R99R0503	DANGELO COMPANY	459.25	459.25	0100000093 4300	GF-Unrest-Not Applicable / Materials and Supplies
R99R0507	SCHOOL FIX	612.96	612.96	0100000092 4300	GF-Unrest-Not Applicable / Materials and Supplies
R99R0508	PDQ EQUIPMENT RENTAL	382.11	382.11	0100000098 5610	GF-Unrest-Not Applicable / Rentals & Leases
R99R0509	TOM'S PLUMBING SERVICE	2,425.00	1,850.00	0100000089 5630	GF-Unrest-Not Applicable / Repairs or Maintenance
			575.00	0100000093 5630	GF-Unrest-Not Applicable / Repairs or Maintenance
R99R0510	PLUMBING WHOLESALE OUTLET	395.35	29.12	0100000092 4300	GF-Unrest-Not Applicable / Materials and Supplies
			24.88	0100000093 4300	GF-Unrest-Not Applicable / Materials and Supplies
			341.35	0100000098 4300	GF-Unrest-Not Applicable / Materials and Supplies
R99R0513	LA HABRA AREA CHAMBER OF COMME	50.00	50.00	0100000317 4300	GF_UNRESTRICTED_SUPPT / Materials and Supplies
R99R0514	OCDE	75.00	75.00	0100000071 5200	GF-Unrest-Not Applicable / Travel and Conferences
R99T0067	MONOPRICE INC.	236.03	236.03	0108880039 4300	GF-Technology-Not Applicable / Materials and Supplies
R99T0069	POWER SCHOOL GROUP LLC	1,387.62	1,387.62	0108880020 5810	GF-Technology-Not Applicable / Licenses/Technology
S99R0012	CODESP	2,200.00	2,200.00	0100000071 5300	GF-Unrest-Not Applicable / Dues and Memberships
S99R0013	LAKESHORE LEARNING MATERIALS	374.50	374.50	0156400007 4300	GF-Medi-Cal-Not Applicable / Materials and Supplies
S99R0016	COASTAL ENTERPRISES	4,644.41	4,644.41	0109110014 4300	GF-DonRS / Materials and Supplies
S99R0017	REHABMART	1,238.22	1,238.22	0165010001 4300	GF-SpEd-LowIncid-Not Applicabl / Materials and Supplies
S99R0019	SCHOOL SPECIALTY LLC	33,192.23	33,192.23	0126000006 4300	ELOP/Site Admin. / Materials and Supplies
S99R0020	SOUTHERN CALIFORNIA SCIENCE OL	120.00	120.00	0105110044 4300	GF-SiteAlloc RS / Materials and Supplies
S99R0021	DEMCO	337.18	337.18	0105110044 4300	GF-SiteAlloc RS / Materials and Supplies
S99S0002	CDW GOVERNMENT INC.	1,075.58	1,075.58	0108880006 4300	GF-TechAllocMG / Materials and Supplies
S99T0002	LIBRARY WORLD INC	2,970.00	495.00	0108880055 5810	GF-Technology-Not Applicable / Licenses/Technology

LOWELL JOINT SD
PURCHASE ORDER DETAIL REPORT
 BOARD OF TRUSTEES MEETING 08/08/2022

FROM 06/01/2022 TO 06/30/2022

<u>PO NUMBER</u>	<u>VENDOR</u>	<u>PO TOTAL</u>	<u>ACCOUNT AMOUNT</u>	<u>ACCOUNT NUMBER</u>	<u>PSEUDO / OBJECT DESCRIPTION</u>
*** CONTINUED ***					
S99T0002			495.00	0108880056 5810	GF-Technology-Not Applicable / Licenses/Technology
			495.00	0108880057 5810	GF-Technology-Not Applicable / Licenses/Technology
			495.00	0108880058 5810	GF-Technology-Not Applicable / Licenses/Technology
			495.00	0108880059 5810	GF-Technology-Not Applicable / Licenses/Technology
			495.00	0108880060 5810	GF-Technology-Not Applicable / Licenses/Technology
S99T0003	INCIDENT IQ LLC	6,914.00	6,914.00	0108880020 5810	GF-Technology-Not Applicable / Licenses/Technology
S99T0004	CDW GOVERNMENT INC.	617.31	617.31	0100890005 4300	GF-TechAllocIt / Materials and Supplies
S99T0005	DATA IMPRESSIONS	16,844.71	2,741.44	0108880033 5810	GF-Technology-Not Applicable / Licenses/Technology
			2,426.44	0108880034 5810	GF-Technology-Not Applicable / Licenses/Technology
			2,493.99	0108880035 5810	GF-Technology-Not Applicable / Licenses/Technology
			2,903.45	0108880036 5810	GF-Technology-Not Applicable / Licenses/Technology
			2,475.95	0108880037 5810	GF-Technology-Not Applicable / Licenses/Technology
			3,803.44	0108880038 5810	GF-Technology-Not Applicable / Licenses/Technology
S99T0006	APPLE INC.	2,042.52	2,042.52	0156400013 4300	GF-Medi-Cal-Not Applicable / Materials and Supplies
S99T0007	GIGAKOM	98,635.89	12,701.90	0108880014 6400	GF-Technology-Not Applicable / Equipment
			12,701.90	0108880015 6400	GF-Technology-Not Applicable / Equipment
			6,350.95	0108880016 6400	GF-Technology-Not Applicable / Equipment
			12,701.88	0108880017 6400	GF-Technology-Not Applicable / Equipment
			6,350.95	0108880018 6400	GF-Technology-Not Applicable / Equipment
			47,828.31	0108880019 6400	GF-Technology-Not Applicable / Equipment
S99T0008	STS EDUCATION	27,342.01	10,665.59	0108110004 4400	RS/TechAllocation / Non Capitalized Equipment
			16,676.42	0132170002 4400	ELOG-GEERUI/RS / Non Capitalized Equipment
		Fund 01 Total:			
					648,211.51
		Fund 18 Total:			2,628.46
		Fund 21 Total:			25,640.00
		Fund 25 Total:			1,161.00

LOWELL JOINT SD

PURCHASE ORDER DETAIL REPORT

BOARD OF TRUSTEES MEETING 08/08/2022

FROM 06/01/2022 TO 06/30/2022

<u>PO NUMBER</u>	<u>VENDOR</u>	<u>PO TOTAL</u>	<u>ACCOUNT AMOUNT</u>	<u>ACCOUNT NUMBER</u>	<u>PSEUDO / OBJECT DESCRIPTION</u>
		Fund 40 Total:	10,771.42		
		Total Amount of Purchase Orders:	688,412.39		

LOWELL JOINT SCHOOL DISTRICT
August 8, 2022

To: President Salinas and Members, Board of Trustees

From: Jim Coombs, Superintendent of Schools

Subject: Consolidated Check Register Listing Report
2022/23 #1

ACTION/
(RATIFICATION)

The Consolidated Check Register Listing Report 2022/23 #1 is recommended for approval.
The consolidated check register lists all warrants issued June 1, 2022, through June 30, 2022.

AR

Attachment

Superintendent's Comment:

APPROVAL RECOMMENDED.

X-B2-1

LOWELL JOINT SD
Consolidated Check Register
 from 6/1/2022 to 6/30/2022

Check	Payee ID	Payee Name	Reference	Subs	Check Date	Cancel Date	Type	Status	Check Amount
99 00001595	V9900010	ALLIANCE OF SCHOOLS FOR COOPER	050122VSR	OH	06/01/2022		MTW	IS	38,197.81
99 00001596	U9900001	CITY OF LA HABRA WATER DEPARTM	0402050222	OH	06/01/2022		MTW	IS	817.98
99 00001597	U9900005	SOUTHERN CALIFORNIA GAS CO	0415051622MYB	OH	06/01/2022		MTW	IS	27.54
99 00001598	U9900009	VERIZON WIRELESS-LA	9906660385	OH	06/01/2022		MTW	IS	1,763.18
99 00001599	U9900010	WARE DISPOSAL	956813	OH	06/01/2022		MTW	IS	4,063.65
99 00001600	F9900014	BUG FLIP	MAY2022	OH	06/01/2022		MTW	IS	180.00
99 00001601	N9900006	FORM PLASTICS COMPANY	APRMAY2022	OH	06/01/2022		MTW	IS	3,186.95
99 00001602	F9900045	LADY BUGS ENVIRONMENTAL TERMIT	23243	OH	06/01/2022		MTW	IS	55.00
99 00001603	N9900011	SANDLER BROTHERS	0236164-IN	OH	06/01/2022		MTW	IS	323.70
99 00001604	U9900004	SOUTHERN CALIFORNIA EDISON	0422052222	OH	06/02/2022		MTW	IS	1,843.77
99 00001605	U9900005	SOUTHERN CALIFORNIA GAS CO	0422052322	OH	06/02/2022		MTW	IS	167.80
99 00001606	V9900376	GoTo Communications Inc.	IN7101176669	OH	06/03/2022		MTW	IS	4,463.89
99 00001607	I9900007	LEES, DEBRA	MAY 2022	OH	06/03/2022		MTW	IS	1,400.00
99 00001608	F9900060	THE SHERWIN-WILLIAMS CO.	5450-06	OH	06/03/2022		MTW	IS	624.07
99 00001609	V99003422	Lux Bus America	50537	OH	06/07/2022		MTW	IS	1,000.00
99 00001610	E9900140	MARY JO EVANOFF	MAY-REIMBURS	OH	06/07/2022		MTW	IS	372.28
99 00001611	F9900052	PDQ EQUIPMENT RENTAL	734323	OH	06/07/2022		MTW	IS	330.00
99 00001612	F9900069	WALTERS WHOLESAL ELECTRIC	SI24071424002	OH	06/07/2022		MTW	IS	2,484.47
99 00001613	N9900004	DRIFTWOOD DAIRY	MAY2022	OH	06/07/2022		MTW	IS	14,030.51
99 00001614	N9900009	P & R PAPER SUPPLY COMPANY	MAY2022	OH	06/07/2022		MTW	IS	6,457.02
99 00001615	N9900013	SOUTHERN CALIFORNIA PIZZA	MAY2022	OH	06/07/2022		MTW	IS	16,546.40
99 00001616	V9900003	ACCO BRANDS USA LLC	4719696715	OH	06/08/2022		MTW	IS	390.29
99 00001617	V9900007	ACTON TROPHY	91632	OH	06/08/2022		MTW	IS	160.21
99 00001618	V99003352	ACTIVE EDUCATION	2201	OH	06/08/2022		MTW	IS	6,656.00
99 00001619	I9900001	ANGIE HUTCHERSON	MAY/JUNE 2022	OH	06/08/2022		MTW	IS	740.04
99 00001620	V9900015	APPLE INC.	AJ02331778	OH	06/08/2022		MTW	IS	174.20
99 00001621	V9900024	BEARCOM	5367775	OH	06/08/2022		MTW	IS	1,229.25
99 00001622	V9900028	BUENA PARK PLAQUE & TROPHY	19249	OH	06/08/2022		MTW	IS	80.81
99 00001623	V9900037	CENGAGE LEARNING	77771274	OH	06/08/2022		MTW	IS	9,568.60
99 00001624	V9900371	CHRIS BECERRA CONSULTING SERVI	MAY 2022 SVCS	OH	06/08/2022		MTW	IS	7,125.00
99 00001625	V9900040	COLLEGE BOARD	EP00133455	OH	06/08/2022		MTW	IS	2,091.00
99 00001626	I9900009	DYLAN ROCKENBACH	MEADOWGRN-21/	OH	06/08/2022		MTW	IS	1,617.00
99 00001627	E9900066	EMILY MONTES	COFA-5/16/22	OH	06/08/2022		MTW	IS	62.14
99 00001628	V99003282	GOVCONNECTON INC.	72824758	OH	06/08/2022		MTW	IS	877.97

LOWELL JOINT SD
Consolidated Check Register
 from 6/1/2022 to 6/30/2022

Check	Payee ID	Payee Name	Reference	Subs	Check Date	Cancel Date	Type	Status	Check Amount
99 00001629	V9903402	HEAR NOW	22202	OH	06/08/2022		MTW	IS	370.00
99 00001630	V9900084	HUGHTON MIFFLIN HARCOURT	955564418	OH	06/08/2022		MTW	IS	3,931.26
99 00001631	E9900084	JIM COOMBS	MGMTRTREAT.HOH	OH	06/08/2022		MTW	IS	843.42
99 00001632	V9903316	NAPA AUTO PARTS	43022	OH	06/08/2022		MTW	IS	30.83
99 00001633	V9903389	PEAR-PRESIDENT'S EDUCATION AWA	477173	OH	06/08/2022		MTW	IS	181.43
99 00001634	V9900148	QUADIEN'T FINANCE USA INC.	QUAD ACCT#3175	OH	06/08/2022		MTW	IS	6,619.40
99 00001635	V9900149	QUADIEN'T LEASING USA INC.	N9419644	OH	06/08/2022		MTW	IS	1,167.58
99 00001636	V9900179	SOUTHWEST SCHOOL SUPPLY	R99X0023SUMME	OH	06/08/2022		MTW	IS	1,940.20
99 00001637	V9900180	SPARKLETT'S	15734879060522	OH	06/08/2022		MTW	IS	162.28
99 00001638	V9903359	WESTONE AUDIO	60755709	OH	06/08/2022		MTW	IS	199.00
99 00001639	B9990010	ERICKSON-HALL CONSTRUCTION	PAY APP# 13	OH	06/08/2022		MTW	IS	339,571.32
99 00001640	B9990011	GHATAODE BANNON ARCHITECTS	4805	OH	06/08/2022		MTW	IS	16,872.80
99 00001641	V9900160	RMA GROUP	79744	OH	06/08/2022		MTW	IS	15,280.75
99 00001642	V9900076	FULLERTON JOINT UNION HS DIST	70RJ0120	OH	06/08/2022		MTW	IS	1,161.00
99 00001643	V9900013	AMERICAN EXPRESS	ZOOM-MAY 2022	OH	06/09/2022		MTW	IS	6,317.68
99 00001644	V9900053	DATA IMPRESSIONS	19286-IN	OH	06/09/2022		MTW	IS	18,515.75
99 00001645	V9903271	J TAYLOR EDUCATION INC	0522-17	OH	06/13/2022		MTW	IS	727.65
99 00001646	V9903428	LACOE SFS	SUBSCRIP'TION	OH	06/13/2022		MTW	IS	5,316.00
99 00001647	V9900125	MYSTERY SCIENCE	SP-9528	OH	06/13/2022		MTW	IS	5,365.50
99 00001648	U9900001	CITY OF LA HABRA WATER DEPARTM	04020502220L	OH	06/16/2022		MTW	IS	3,506.93
99 00001649	U9900002	FRONTIER	JUNE22	OH	06/16/2022		MTW	IS	65.82
99 00001650	S9990002	GALLAGHER PEDIATRIC THERAP	9849	OH	06/16/2022		MTW	IS	2,649.53
99 00001651	F9900033	GLASBY MAINTENANCE SUPPLY	324277	OH	06/16/2022		MTW	IS	14,038.17
99 00001652	U9900003	MCI A VERIZON COMPANY	409078455	OH	06/16/2022		MTW	IS	4.72
99 00001653	E9900147	MICHELLE BOHEN	061322	OH	06/16/2022		MTW	IS	75.40
99 00001654	V9903405	PARENTPOWERED PBC	1100	OH	06/16/2022		MTW	IS	1,745.00
99 00001655	U9900004	SOUTHERN CALIFORNIA EDISON	0511060922	OH	06/16/2022		MTW	IS	17,465.98
99 00001656	U9900005	SOUTHERN CALIFORNIA GAS CO	0429053122	OH	06/16/2022		MTW	IS	205.56
99 00001657	U9900006	SUBURBAN WATER SYSTEMS	181003219784	OH	06/16/2022		MTW	IS	23,040.59
99 00001658	U9900008	T-MOBILE	0504060322	OH	06/16/2022		MTW	IS	819.36
99 00001659	U9900010	WARE DISPOSAL	995613	OH	06/16/2022		MTW	IS	3,252.47
99 00001660	N9900015	Continental Sales	MAY2022	OH	06/16/2022		MTW	IS	16,722.00
99 00001661	N9900007	GOLD STAR FOODS	MAY2022	OH	06/16/2022		MTW	IS	23,111.71
99 00001662	E9900004	ALAN MAO	MISC-CHROME/BK	OH	06/17/2022		MTW	IS	140.47

LOWELL JOINT SD
Consolidated Check Register
 from 6/1/2022 to 6/30/2022

Check	Payee ID	Payee Name	Reference	Subs	Check Date	Cancel Date	Type	Status	Check Amount
99 00001663	V9903424	ANYWHERE CART	169622	OH	06/17/2022		MTW	IS	367.13
99 00001664	R9900001	BRENT ALLSMAN	JULY2022	OH	06/17/2022		MTW	IS	557.02
99 00001665	R9903247	CAROLYN KANE	JULY2022	OH	06/17/2022		MTW	IS	1,290.56
99 00001666	R9900003	CLAUDIA SCHALCHLIN	JULY2022	OH	06/17/2022		MTW	IS	570.78
99 00001667	E9903244	CRISTIAN BOGDAN	MILEAGE	OH	06/17/2022		MTW	IS	36.97
99 00001668	V9900048	CSM CONSULTING INC.	14952	OH	06/17/2022		MTW	IS	5,675.92
99 00001669	E9900051	DAVID BENNETT	LUNCH 6-30-2022	OH	06/17/2022		MTW	IS	208.34
99 00001670	R9900014	EDDY VEGA	JULY2022	OH	06/17/2022		MTW	IS	557.02
99 00001671	R9900006	EMILY WAKEFIELD	JULY2022	OH	06/17/2022		MTW	IS	570.78
99 00001672	R9900007	GAYLE ROGERS	JULY2022	OH	06/17/2022		MTW	IS	232.94
99 00001673	V9903282	GOVCONNECTION INC.	72865528	OH	06/17/2022		MTW	IS	4,731.82
99 00001674	F9900038	ICS SERVICE COMPANY	34316	OH	06/17/2022		MTW	IS	1,819.10
99 00001675	V9900088	IMPERIAL BAND INSTRUMENTS	M63881	OH	06/17/2022		MTW	IS	693.99
99 00001676	V9900088	IMPERIAL BAND INSTRUMENTS	M67350	OH	06/17/2022		MTW	IS	345.38
99 00001677	V9900088	IMPERIAL BAND INSTRUMENTS	56101	OH	06/17/2022		MTW	IS	165.48
99 00001678	E9900087	JOHN ZAPPULLA	MILEAGE-MAY	OH	06/17/2022		MTW	IS	45.50
99 00001679	R9903248	JULIE ROTH	JULY2022	OH	06/17/2022		MTW	IS	570.78
99 00001680	E9900099	KARI HEINRICH	ESY SUPPLIES	OH	06/17/2022		MTW	IS	47.63
99 00001681	V9900099	LA HABRA AREA CHAMBER OF COMME	REGISTRATION	OH	06/17/2022		MTW	IS	150.00
99 00001682	R9900013	MARGARET DUMADAG	JULY2022	OH	06/17/2022		MTW	IS	557.02
99 00001683	V9900123	MONORICE INC.	22665823	OH	06/17/2022		MTW	IS	247.04
99 00001684	R9900009	NANCY WHITE	JULY2022	OH	06/17/2022		MTW	IS	1,290.56
99 00001685	V9900134	OCDE	94RL4998	OH	06/17/2022		MTW	IS	4,200.00
99 00001686	R9900010	PENNY MAYERCHECK	JULY2022	OH	06/17/2022		MTW	IS	1,290.56
99 00001687	V9900142	POWER SCHOOL GROUP LLC	307632	OH	06/17/2022		MTW	IS	1,387.62
99 00001688	R9900011	RONALD RANDOLPH	JULY2022	OH	06/17/2022		MTW	IS	614.88
99 00001689	R9900012	SHELLEY MARKER	JULY2022	OH	06/17/2022		MTW	IS	570.78
99 00001690	V9900200	UNUM LIFE INSURANCE COMPANY	BL0160188JUN22	OH	06/17/2022		MTW	IS	542.73
99 00001691	U9900010	WARE DISPOSAL	995603	OH	06/17/2022		MTW	IS	854.45
99 00001692	R9900002	BRUCE PATULLO	JULY2022	OH	06/17/2022		MTW	IS	557.02
99 00001693	V9903306	GAMETIME	0178270 0178274	OH	06/17/2022		MTW	IS	127,811.72
99 00001694	B9990013	HAUFFE COMPANY	436	OH	06/17/2022		MTW	IS	14,112.00
99 00001695	V9903394	AMSCOPE	474250	OH	06/20/2022		MTW	IS	338.73
99 00001696	F9900014	BUG FLIP	478226	OH	06/20/2022		MTW	IS	1,280.00

LOWELL JOINT SD
Consolidated Check Register
 from 6/1/2022 to 6/30/2022

Check	Payee ID	Payee Name	Reference	Subs	Check Date	Cancel Date	Type	Status	Check Amount
99 00001697	V9903431	CALPERS	100000016838395	OH	06/20/2022		MTW	IS	440,000.00
99 00001698	V9903362	DELL MARKETING I.P.	10592040642	OH	06/20/2022		MTW	IS	3,805.27
99 00001699	V9900056	DELTA DENTAL OF CALIFORNIA	BE004987453	OH	06/20/2022		MTW	IS	1,951.21
99 00001700	F9900039	IMPERIAL SPRINKLER SUPPLY	5092615	OH	06/20/2022		MTW	IS	3,714.32
99 00001701	V9900094	J.W.PEPPER & SON INC.	364231739	OH	06/20/2022		MTW	IS	282.14
99 00001702	V9903291	JEANETTE TREVINO	REIMBURSEMENT	OH	06/20/2022		MTW	IS	26.95
99 00001703	F9900047	LOWES	961011	OH	06/20/2022		MTW	IS	271.30
99 00001704	V9903429	RANCHERS IRRIGATION SUPPLY	5158	OH	06/20/2022		MTW	IS	281.69
99 00001705	V9900154	READYREFRESH BY NESTLE	02F0032621385	OH	06/20/2022		MTW	IS	73.85
99 00001706	V9900169	SCHOOL DATEBOOKS	S22-0226708	OH	06/20/2022		MTW	IS	803.68
99 00001707	V9900172	SCHOOL SERVICES OF CALIFORNIA	0133680-IN	OH	06/20/2022		MTW	IS	340.00
99 00001708	V9903299	SCHOOL SPECIALTY LLC	208129990810	OH	06/20/2022		MTW	IS	1,592.52
99 00001709	V9900179	SOUTHWEST SCHOOL SUPPLY	STHWST	OH	06/20/2022		MTW	IS	8,117.36
99 00001710	V9903425	SPORTS JACKETS UNLIMITED	4557	OH	06/20/2022		MTW	IS	460.85
99 00001711	V9900183	STUDIES WEEKLY	437629	OH	06/20/2022		MTW	IS	13,056.07
99 00001712	I9900011	TRINIDAD, GINA	RS-86137-017	OH	06/20/2022		MTW	IS	2,095.83
99 00001713	V9900204	VIG SOLUTIONS	11048	OH	06/20/2022		MTW	IS	325.24
99 00001714	V9903396	WARD'S MEDIA TECH	154391	OH	06/20/2022		MTW	IS	30,200.78
99 00001715	V9903430	DANGELO COMPANY	S1466487.001	OH	06/24/2022		MTW	IS	38.87

Issued: 1,342,256.27
 99 Bank Total: 1,342,256.27
 Grand Total: 1,342,256.27

LOWELL JOINT SCHOOL DISTRICT
August 8, 2022

To: President Salinas and Members, Board of Trustees

From: Jim Coombs, Superintendent of Schools

Subject: Approval of Contract with Whittier Christian High School, for Student transportation to and from the Meadow Green and Maybrook Campuses during Meadow Green Modernization (Bond Fund) ACTION

Background:

On November 6, 2018, the voters in the Lowell Joint School District passed measure “LL”. As part of housing students and staff during the renovations of their own home campus, it became necessary to engage a cooperative taxi service that was already providing shuttle services for the Special Education department, to provide transportation services for some Jordan students to Maybrook and back to Jordan during the Jordan modernization project June 2021 to March 2022.

With the mobilization of Erickson Hall Construction Company onto the Meadow Green campus on June 13, 2022, it will become necessary for Meadow Green students to be transported to and from the Meadow Green and Maybrook campus’s during the 2022/2023 school year during the Meadow Green modernization project.

Current Considerations:

As part of the Meadow Green/Maybrook planning process, the District became aware of a need for increased transportation services for Meadow Green students over the Jordan students and sought comprehensive and cost effective pricing from other various providers.

Whittier Christian High School has provided the District with a proposal for 62 students to be transported from the Meadow Green campus to the Maybrook campus and back to Meadow Green on one bus for 180 days for a fee of \$300 per day for a total of \$54,000 for the base line contract.

In addition to the base line contract, Whittier Christian High School may provide transportation during the 30 additional “intersession” days required of the ELOP program for a total of 210 days at a rate of \$300 per day.

The District is asking that the Board of Trustees approve a contract for a not to exceed amount of \$68,250 to accommodate any unforeseen issues for the 22/23 school year should there be any change in student enrollment or need. Any encumbered funds remaining on the purchase order at the end of the District fiscal year would be liquidated and returned to the Bond Fund.

Financial Implications

Superintendent’s Comment:

APPROVAL RECOMMENDED.

Financial Impact: \$68,250

Funding Source: Measure LL General Obligation Fund - Fund 21.0

Recommendation:

It is recommended that the Board of Trustees approve a Contracted Services Agreement with Whittier Christian High School, for student transportation to and from the Meadow Green and Maybrook Campuses, effective August 9, 2022 through August 15, 2023, not to exceed \$68,250 Measure LL General Obligation Fund (21.0) and that the Superintendent or designee be authorized to execute the necessary documents.

Superintendent's Comment:

APPROVAL RECOMMENDED.

LOWELL JOINT SCHOOL DISTRICT
August 8, 2022

To: President Salinas and Members, Board of Trustees

From: Jim Coombs, Superintendent of Schools

Subject: Approval of Agreement with Administrative Services Cooperative, Inc. for Student Transportation Services for the 2022/2023 School Year Not to Exceed \$150,000 ACTION

A bid for transportation services of our special education student was conducted and awarded to Administrative Services Cooperative, Inc. beginning with the 2018/19 school year. This bid is renewable annually up to a total of five years. The pricing for the 2022/23 school year is increasing approximately eleven percent due to increased gas prices and Los Angeles Department of Transportation fee increases.

The previous year expenses were approximately \$110,000, so the projected costs for 2022/23 would be approximately \$123,000. To allow for increased ridership due to a growing special education population, it is recommended to approve this contract for a not to exceed amount of \$150,000. This fee includes extended school year (ESY) transportation.

It is recommended that the Agreement with Administrative Services Cooperative, Inc. for Student Transportation Services for the 2022/2023 School Year Not to Exceed \$150,000, be approved and that the Superintendent or designee be authorized to execute the necessary documents.

AR

Superintendent's Comment:

APPROVAL RECOMMENDED.

L OWELL JOINT SCHOOL DISTRICT
August 8, 2022

To: President Salinas and Members, Board of Trustees

From: Jim Coombs, Superintendent of Schools

Subject: Approval of Agreement with Geraldine Chinarian, ACTION
for Specialized Consulting Services

The District has a need of specialized consulting services in the area of fiscal services and related areas. Ms. Chinarian is retired from Anaheim Union High School District after twenty one years of service. Ms. Chinarian has over thirty years experience in school finance and worked in the position of Budget Manager for Anaheim Union for 17 years. Anaheim Union's budget size was \$479 million. Ms. Chinarian was responsible for the budget preparation of the Adopted Budget and Interim Budgets. Ms. Chinarian will assist the staff in the fiscal services department with understanding the salaries and benefits budget preparation process, and it's interaction with the position control system in the Orange County financial systems we are learning to use since transitions from Los Angeles County Office of Education to Orange County Department of Education. This assistance will occur during the 2022/23 fiscal year. The hourly rate for these services will be \$100. Four hundred (400) hours are estimated at this time to assist in these areas. The term of this agreement will be August 9, 2022, through June 30, 2023.

It is recommended that the agreement with Geraldine Chinarian, be approved, not to exceed four hundred (400) hours, and that the Superintendent or designee be authorized to execute the necessary documents.

AR

Superintendent's Comment:

APPROVAL RECOMMENDED.

LOWELL JOINT SCHOOL DISTRICT
August 8, 2022

To: President Salinas, and Members, Board of Trustees

From: Jim Coombs, Superintendent of Schools

Subject: Budget Adjustments 2021/22 – Estimated Actuals ACTION

With the change of fiscal oversight from Los Angeles County Office of Education to Orange County Department of Education (OCDE), budget transfers are not required to be submitted to OCDE. With each Budget Report presented to the board, the standardized report format usually shows the changes between the Board approved budget and the new Projected Budget in Column (E) Difference. The only time this budget report does not show this difference column is when the Adopted Budget and the Estimated Actuals are presented when adopting a new fiscal year budget. Therefore, we are presenting these budget differences to the board for approval to document these changes.

Budget Adjustments for 2021/22 Estimated Actuals budget changes from Second Interim budget are attached and recommended for approval of the following adjustments:

- Fund 01.0 General Fund/Unrestricted and Restricted
- Fund 13.0 Cafeteria/Restricted
- Fund 14.0 Deferred Maintenance/Restricted
- Fund 21.0 Building Fund
- Fund 25.0 Capital Facilities Fund/Restricted
- Fund 40.0 Special Reserve for Capital Outlay Projects/Restricted

It is recommended that Budget Adjustments for 2021/22 Estimated Actuals be approved, and that the Superintendent or designee be authorized to execute and file the necessary documents.

AR

Attachments

Superintendent's Comment:

APPROVAL RECOMMENDED.

Lowell Joint School District

2021-22 Estimated Actuals Budget Adjustment Summary

Fund 01 - General Fund - Unrestricted/Restricted

Description	Object	SI21-22	EA21-22	Change
Revenues	8000	\$38,075,453	\$38,877,856	\$802,403
Certificated Salaries	1000	\$16,405,949	\$16,678,209	\$272,260
Classified Salaries	2000	\$5,537,734	\$5,470,263	-\$67,471
Employee Benefits	3000	\$9,611,346	\$9,768,375	\$157,029
Books and Supplies	4000	\$3,915,824	\$3,912,047	-\$3,777
Services & Other Operating Exp.	5000	\$3,490,495	\$2,954,136	-\$536,359
Capital Outlay	6000	\$78,390	\$78,389	-\$1
Other Outgo	7100-7299 7400-7499	\$387,200	\$363,537	-\$23,663
Other Outgo	7300-7399	-\$50,000	-\$45,800	\$4,200
Total Expenditures				-\$197,782
Fund Balance Adjustment Total				\$1,000,185

Lowell Joint School District

2021-22 Estimated Actuals Budget Adjustment Summary

Fund 13 - Cafeteria Fund

Description	Object	SI21-22	EA21-22	Change
Revenues	8000	\$898,516	\$1,987,019	\$1,088,503
Certificated Salaries	1000	-	-	
Classified Salaries	2000	\$552,123	\$540,772	-\$11,351
Employee Benefits	3000	\$189,786	\$182,661	-\$7,125
Books and Supplies	4000	\$501,653	\$651,548	\$149,895
Services & Other Operating Exp.	5000	\$30,286	\$18,228	-\$12,058
Capital Outlay	6000	\$100,000	\$0	-\$100,000
Other Outgo	7000	\$50,000	\$45,800	-\$4,200
Total Expenditures				\$15,161
Fund Balance Adjustment Total				\$1,073,342

Lowell Joint School District

2021-22 Estimated Actuals Budget Adjustment Summary

Fund 14 - Deferred Maintenance Fund

Description	Object	SI21-22	EA21-22	Change
Revenues	8000	\$55,632	\$91,513	\$35,881
Certificated Salaries	1000	-	-	
Classified Salaries	2000	\$58,944	\$58,944	\$0
Employee Benefits	3000	\$49,398	\$42,398	-\$7,000
Books and Supplies	4000	\$5,000	\$5,000	\$0
Services & Other Operating Exp.	5000	\$446,018	\$500,000	\$53,982
Capital Outlay	6000	\$224,534	\$224,534	\$0
Other Outgo	7000	\$0	\$0	\$0
Total Expenditures				\$46,982
Fund Balance Adjustment Total				-\$11,101

Lowell Joint School District

2021-22 Estimated Actuals Budget Adjustment Summary

Fund 21 - Building Fund

Description	Object	SI21-22	EA21-22	Change
Revenues	8000	\$120,000	\$161,338	\$41,338
Certificated Salaries	1000	-	-	
Classified Salaries	2000	\$82,516	\$82,516	\$0
Employee Benefits	3000	\$36,994	\$36,994	\$0
Books and Supplies	4000	\$0	\$0	\$0
Services & Other Operating Exp.	5000	\$516,466	\$511,974	-\$4,492
Capital Outlay	6000	\$12,356,977	\$11,600,021	-\$756,956
Other Outgo	7000	\$0	\$0	\$0
Total Expenditures				-\$761,448
				Fund Balance Adjustment Total \$802,786

Lowell Joint School District

2021-22 Estimated Actuals Budget Adjustment Summary

Fund 25 - Capital Facilities Fund

Description	Object	SI21-22	EA21-22	Change
Revenues	8000	\$25,400	\$36,709	\$11,309
Certificated Salaries	1000	-	-	
Classified Salaries	2000	\$0	\$0	\$0
Employee Benefits	3000	\$0	\$0	\$0
Books and Supplies	4000	\$0	\$0	\$0
Services & Other Operating Exp.	5000	\$330	\$1,000	\$670
Capital Outlay	6000	\$1,000,000	\$1,000,000	\$0
Other Outgo	7000	\$0	\$0	\$0
Total Expenditures				\$670
Fund Balance Adjustment Total				\$10,639

Lowell Joint School District

2021-22 Estimated Actuals Budget Adjustment Summary

Fund 40 - Capital Outlay Projects

Description	Object	SI21-22	EA21-22	Change
Revenues	8000	\$4,049,552	\$4,191,356	\$141,804
Certificated Salaries	1000	-	-	
Classified Salaries	2000	-	-	
Employee Benefits	3000	-	-	
Books and Supplies	4000	\$5,366	\$19,400	\$14,034
Services & Other Operating Exp.	5000	\$225,184	\$164,244	-\$60,940
Capital Outlay	6000	\$129,000	\$157,582	\$28,582
Other Outgo	7000	\$0	\$0	\$0
Total Expenditures				-\$18,324
			Fund Balance Adjustment Total	\$160,128

LOWELL JOINT SCHOOL DISTRICT

August 8, 2022

To: President Salinas and Members, Board of Trustees

From: Jim Coombs, Superintendent of Schools

Subject: Employer-Employee Relations/Personnel Report 2022/2023 #1
Which Includes Hiring, Resignations, Contract Adjustments,
and Retirements for Certificated, Classified, and Confidential
Employees

ACTION/
(RATIFICATION)

The attached Employer-Employee Relations/Personnel Report 2022/2023 #1, which includes hiring, resignations, contract adjustments, and retirements for certificated, classified, and confidential employees has been completed without irregularities and in compliance with the law, District policy, administrative regulations, rules, procedures, and direction of the supervisor and all information has been fully disclosed.

It is recommended that Employer-Employee Relations/Personnel Report 2022/2023 #1, which includes hiring, resignations, contract adjustments, and retirements for certificated, classified, and confidential employees, be ratified.

Attachment

JC/me

Superintendent's Comment:

APPROVAL RECOMMENDED.

LOWELL JOINT SCHOOL DISTRICT
EMPLOYER-EMPLOYEE RELATIONS PERSONNEL REPORT 2022/2023 #1

August 8, 2022

I. CERTIFICATED EMPLOYEES

A. RESIGNATION				
NAME	<u>EFFECTIVE DATE</u>	SITE	COMMENTS	
Garduno, Adam	07/07/2022	RS	Resignation. Rancho Starbuck Teacher.	
B. 2022/2023 CONTRACTS				
NAME	<u>EFFECTIVE DATE</u>	<u>CLASS/COL/STEP</u>	SITE	COMMENTS
Woo, Chuck	08/15/2022	C4/S6	RS	Temporary Contract. Rancho Starbuck Math Teacher Teacher

* It is further recommended that these individuals be approved for substitute teaching at the rate of \$200.00 per day and/or \$35.00 an hour rate (not to exceed six hours) as applicable and to include: Professional Development, Saturday School, Site Support Duties and Intervention Programs. The rate of pay is \$35.00/hour and will be paid from Title I or LCFF Supplemental Grant Funds.

**It is further recommended that the individuals listed in Certificated Salaries for 2022-2023 is approved to instruct in the Intervention Programs. The rate of pay is \$35.00/hour and will be paid from Title I or LCFF Supplemental Grant Funds.

**It is further recommended that individuals listed in Certificated Salaries for 2022-2023 serve as home school teachers, if needed, for the 2022-2023 school year at a rate of \$35.00/hour, not to exceed five hours per week, per student. Mileage will be paid at the IRS Standard Mileage Rate for the 2022-2023 school year.

II. CLASSIFIED EMPLOYEES August 8, 2022

<u>NAME/ EMPLOYEE ID#</u>	<u>EFFECTIVE DATE</u>	<u>END DATE</u>	<u>RANGE/ STEP</u>	<u>SITE</u>	<u>COMMENTS</u>
Alarid, Emily	07/25/2022	08/05/2022		DO	Bootcamp: CW 11:00-1:00
Alcantara, Marissa	07/18/2022			MG	Resignation: Noon Duty Aide
Allsman, Katelyn	07/25/2022	08/05/2022	R14/S1	DO	Bootcamp: Noon Duty Aide 11:45-1:15
Anderson, Adriana	07/25/2022	08/05/2022		DO	Bootcamp: CW 10:00-12:00
Ayers, Becca	08/15/2022	12/23/2022		OL	Unpaid Leave of Absence - IA
Barber, Stephanie	07/17/2022			DO	Resignation: Admin Asst. Bus Serv.
Barber, Stephanie	07/18/2022			DO	Substitute: Admin Asst. Bus Serv.
Bautista, Selah	07/18/2022		R21/S7	DO	New Hire: Secretary of Guidance SPED
Castro, Claudia	08/10/2022		R16/S1	JO	New Hire: Clerk Typist
Cramer, Samantha	08/08/2022		R20/S1	TBD	New Hire: Classified Preschool Teacher
Duran, Julie	07/13/2022		R21/S1	DO	Substitute: Admin Asst. Bus Serv.
Edwards, Sarah	07/01/2022	06/30/2023	R28/S3	RS	Maintenance Lockers
Estrada, Liz	07/25/2022	08/05/2022	R14/S6	DO	Bootcamp: IA 7:30-12:30
Felix, Lisa	08/15/2022		R20/S4	MA	New Hire-Librarian/Media Tech
Garcia, Gabriella	03/15/2022	03/25/2022			Resignation: IA, Sped, ABA Substitute
Hernandez, Darlene	07/01/2022	08/14/2022	R14/S1	DO	IA/Substitute/Summer
Hernandez, Darlene	08/15/2022		R14/S1	DO	Substitute Instructional Aide
Hutcheson, Janel	06/06/2022	06/30/2022	R28/S1	RS	Maintenance Lockers
Lepe, Caroline	07/25/2022	08/05/2022	R14/S4	DO	Bootcamp: IA 7:30-12:30
Lopez, Donna	07/25/2022	08/05/2022	R15/S8	DO	Bootcamp: IA Sub 7:30-12:30
Lord, Dixie	06/10/2022	06/30/2022	R28/S3	RS	Maintenance Lockers
Miza, Kelly	08/16/2022	06/02/2023		EP	IA/RSP: Increase hours to 5.50

Muravez, Alicia	07/25/2022	08/05/2022		DO	Bootcamp: SCW 9:30-12:30
Nunez, Marie	07/25/2022	08/08/2022	R1/S1	DO	Bootcamp: Noon Duty Aide 11:45-1:15
Padilla, Myra	06/13/2022		R23/S7	DO	Step Increase-Fiscal Clerk
Perez, Stephanie	08/08/2022		R20/S1	TBD	New Hire-Classified Preschool Teacher
Pullen, Darleene	08/16/2022	06/02/2023		MG	IA/RSP: Increase hours to 5.50
Palmer, Mary	08/16/2023	06/02/2023		RS	IA/RSP: Increase hours to 5.50
Reyatt, Manjit	08/17/2022	11/01/2022	NDA/01/01	MG	Unpaid Leave of Absence-Noon Duty Aide. Correction of EER #12 21-22
Rickenbacker, Kim	08/03/2022		R23/S4	EP	New Hire-Office Manager Correction of Date
Rodia, Sue	08/16/2022	06/02/2023		OL	IA/RSP: Increase hours to 5.50
Roe, Amy	07/11/2022		R	OL	Resignation: Instructional Assistant
Sanchez, Kris	07/25/2022	08/05/2022		DO	Bootcamp: SCW 9:30-12:30
Serrano, Tena	06/09/2022	06/30/2022	R18/S8	RS	Maintenance Lockers
Valdez, Faith	08/16/2022	06/02/2023		MA	IA/RSP: Increase hours to 5.50
Watson, Jill	8/16/2022	06/02/2023		JO	IA/RSP: Increase hours to 5.50
Winik, Rebecca	08/16/2022	06/02/2023		RS	IA/RSP: Increase hours to 5.50
Ybarra, Mariana	07/25/2022	08/05/2022	R14/S8	DO	Bootcamp: IA 7:30-12:30

CLASSIFIED JOB DESCRIPTIONS

Addition:

- Child Development (1)
- Child Development (2)
- Child Development (3)
- Health Technician
- Licensed Vocational Nurse



LOWELL JOINT SCHOOL DISTRICT CHILD DEVELOPMENT ASSISTANT I

Classified Salary Schedule
Range 14

JOB SUMMARY:

Under supervision, assist in the supervision, management, safety and well-being of students during a child development program, which may include a district preschool program and/or a district school age before and after school program.

DISTINGUISHING CHARACTERISTICS:

This classification is distinguished from other Instructional Assistant classifications in that the primary responsibility is working with students in the Child Development department.

ESSENTIAL FUNCTIONS:

The duties listed below are intended only as illustrations of the various types of work that may be performed. The omission of specific statements of duties does not exclude them from the position if the work is similar, related, or a logical assignment to the class.

- Assist teachers in a learning environment designed to develop the physical, cognitive, emotional, creative and social skills of child development students.
- Assist in the preparation of a variety of instructional materials and learning aids designed for learning of child development students.
- Supervise small groups or individual students under the directions of the assigned supervisor; monitor students on the playground.
- Demonstrate standards of behavior and utilize a positive approach while working with children.
- Assist with snacks and other meals as appropriate; set up plates and meals; clean serving area after meals; assist students with cleanliness, brushing teeth and toileting as needed.
- Maintain and assure a clean, safe, attractive and positive learning environment; perform light housekeeping duties, including cleaning the classroom after students leave and preparing for the next day.
- May set up and operate simple audio-visual equipment, assisting students to learn with the use of computers and other teaching aids.
- Assist in administering routine first aid to students as needed; assist in toileting, administering medication and medical procedures in accordance with specific medical instructions as assigned
- Participate in meetings and in-service training programs as assigned.
- Assist with classroom preparation and materials, maintaining a clean and safe learning environment.
- Routinely squat, crouch, sit on small chairs, and hard surfaces with students.
- Perform other related duties as assigned.

QUALIFICATION GUIDELINES:

Knowledge of:

- Basic concepts used in Early Childhood Education/Child Development
- Program policies, practices and procedures.
- Safe classroom and playground practices.
- Health and safety precautions and procedures
- Basic first aid procedures and health and safety regulations.
- Interpersonal relations skills using tact, patience and courtesy.

Ability to:

- Appropriately manage student behavior and guide students toward acceptable social behavior.
- Implement learning activities for children while maintaining a healthy and safe environment.
- Monitor and assist students.
- Squat, crouch or sit on small chairs low to the ground or hard floors.
- Demonstrate understanding, patient and receptive attitude toward students and staff.
- Work confidentially with discretion and independently with little supervision.
- Communicate clearly and concisely, both orally and in writing.
- Establish and maintain cooperative and effective working relationships with others.
- Perform routine clerical duties.
- Lift and move items weighing up to 50 pounds.

Education/Training/Licenses/Experience:

Graduation from high school or its equivalent and must successfully pass the District's local assessment test.

PHYSICAL STANDARDS AND WORKING CONDITIONS:

The physical and mental demands and work environment described here are representative of those that must be met by employees to successfully perform the essential functions of this class. Reasonable accommodations may be made to enable individuals with disabilities to perform the essential functions. These physical demands are generic in nature and tasks may vary dependent on specific trade and or specialized work assignment.

Physical Demands:

Physical demands of this position include sitting and standing for extended periods. The employee may frequently move or lift children weighing up to 50 pounds unassisted. Occasional bending at the waist is required, as is kneeling, crouching, squatting, pushing and pulling. Employees may reach overhead as well as above the shoulders and horizontally.

Mental Demands:

Employee must be able to comprehend and follow written and oral instructions; interpret policies and procedures; and interact cooperatively with District staff, parents, and the public.

Work Environment:

While performing the duties of this job, the employee works in several environments including classroom, indoor and outdoor environments and on or near student playground equipment.

The information contained in the physical standards description is for compliance with ADA and is not an exhaustive list of duties performed. Individuals who hold this position may perform additional duties and additional duties may be assigned.

WORK PERIOD:

10 months per year, 5 days per week, up to 3.75 hours/day



LOWELL JOINT SCHOOL DISTRICT CHILD DEVELOPMENT ASSISTANT 2

Classified Salary Schedule
Range 15

JOB SUMMARY:

Under supervision, assist in the supervision, management, safety and well-being of students during a child development program, which may include a district preschool program and/or a district school age before and after school program.

DISTINGUISHING CHARACTERISTICS:

This classification is distinguished from other Instructional Assistant classifications in that the primary responsibility is working with students in the Child Development department.

ESSENTIAL FUNCTIONS:

The duties listed below are intended only as illustrations of the various types of work that may be performed. The omission of specific statements of duties does not exclude them from the position if the work is similar, related, or a logical assignment to the class.

- Assist teachers in a learning environment designed to develop the physical, cognitive, emotional, creative and social skills of child development students.
- Assist in the preparation of a variety of instructional materials and learning aids designed for learning of child development students.
- Supervise small groups or individual students under the directions of the assigned supervisor; monitor students on the playground.
- Demonstrate standards of behavior and utilize a positive approach while working with children.
- Assist with snacks and other meals as appropriate; set up plates and meals; clean serving area after meals; assist students with cleanliness, brushing teeth and toileting as needed.
- Maintain and assure a clean, safe, attractive and positive learning environment; perform light housekeeping duties, including cleaning the classroom after students leave and preparing for the next day.
- May set up and operate simple audio-visual equipment, assisting students to learn with computers and other teaching aids.
- Assist in administering routine first aid to students as needed; assist in toileting, administering medication and medical procedures in accordance with specific medical instructions as assigned
- Participate in meetings and in-service training programs as assigned.
- Assist with classroom preparation and materials, maintaining a clean and safe learning environment.
- Routinely squat, crouch, sit on small chairs, and hard surfaces with students.
- Perform other related duties as assigned.

QUALIFICATION GUIDELINES:

Knowledge of:

- Basic concepts used in Early Childhood Education/Child Development
- Program policies, practices and procedures.
- Safe classroom and playground practices.
- Health and safety precautions and procedures
- Basic first aid procedures and health and safety regulations.
- Interpersonal relations skills using tact, patience and courtesy.

Ability to:

- Appropriately manage student behavior and guide students toward acceptable social behavior.
- Implement learning activities for children while maintaining a healthy and safe environment.
- Monitor and assist students.
- Squat, crouch or sit on small chairs low to the ground or hard floors.
- Demonstrate understanding, patient and receptive attitude toward students and staff.
- Work confidentially with discretion and independently with little supervision.
- Communicate clearly and concisely, both orally and in writing.
- Establish and maintain cooperative and effective working relationships with others.
- Perform routine clerical duties.
- Lift and move items weighing up to 50 pounds.

Education/Training/Licenses/Experience:

1. Graduation from high school or its equivalent. Must also successfully pass the District's local assessment test.
2. 12 college level units in Early Childhood Education, Child Development, or related field.

PHYSICAL STANDARDS AND WORKING CONDITIONS:

The physical and mental demands and work environment described here are representative of those that must be met by employees to successfully perform the essential functions of this class. Reasonable accommodations may be made to enable individuals with disabilities to perform the essential functions. These physical demands are generic in nature and tasks may vary dependent on specific trade and or specialized work assignment.

Physical Demands:

Physical demands of this position include sitting and standing for extended periods. The employee may frequently move or lift children weighing up to 50 pounds unassisted. Occasional bending at the waist is required, as is kneeling, crouching, squatting, pushing and pulling. Employees may reach overhead as well as above the shoulders and horizontally.

Mental Demands:

Employee must be able to comprehend and follow written and oral instructions; interpret policies and procedures; and interact cooperatively with District staff, parents, and the public.

Work Environment:

While performing the duties of this job, the employee works in several environments including classroom, indoor and outdoor environments and on or near student playground equipment.

The information contained in the physical standards description is for compliance with ADA and is not an exhaustive list of duties performed. Individuals who hold this position may perform additional duties and additional duties may be assigned.

WORK PERIOD:

10 months per year, 5 days per week, up to 3.75 hours/day



LOWELL JOINT SCHOOL DISTRICT CHILD DEVELOPMENT ASSISTANT 3

Classified Salary Schedule
Range 17

JOB SUMMARY:

Under supervision, assists in the supervision, management, safety and well-being of students during a child development program, which may include a district preschool program and/or a district school age before and after school program.

DISTINGUISHING CHARACTERISTICS:

This classification is distinguished from other Instructional Assistant classifications in that the primary responsibility is working with students in the Child Development department.

ESSENTIAL FUNCTIONS:

The duties listed below are intended only as illustrations of the various types of work that may be performed. The omission of specific statements of duties does not exclude them from the position if the work is similar, related, or a logical assignment to the class.

- Assist teachers in a learning environment designed to develop the physical, cognitive, emotional, creative and social skills of child development students.
- Assist in the preparation of a variety of instructional materials and learning aids designed for learning of child development students.
- Supervise small groups or individual students under the directions of the assigned supervisor; monitor students on the playground.
- Demonstrate standards of behavior and utilize a positive approach while working with children.
- Assist with snacks and other meals as appropriate; set up plates and meals; clean serving area after meals; assist students with cleanliness, brushing teeth and toileting as needed.
- Maintain and assure a clean, safe, attractive and positive learning environment; perform light housekeeping duties, including cleaning the classroom after students leave and preparing for the next day.
- May set up and operate simple audio-visual equipment, assisting students to learn with computers and other teaching aids.
- Assist in administering routine first aid to students as needed; assist in toileting, administering medication and medical procedures in accordance with specific medical instructions as assigned
- Participate in meetings and in-service training programs as assigned.
- Assist with classroom preparation and materials, maintaining a clean and safe learning environment.
- Routinely squat, crouch, sit on small chairs, and hard surfaces with students.
- Perform other related duties as assigned.

QUALIFICATION GUIDELINES:

Knowledge of:

- Basic concepts used in Early Childhood Education/Child Development
- Program policies, practices and procedures.
- Safe classroom and playground practices.
- Health and safety precautions and procedures
- Basic first aid procedures and health and safety regulations.
- Interpersonal relations skills using tact, patience and courtesy.

Ability to:

- Appropriately manage student behavior and guide students toward acceptable social behavior.
- Implement learning activities for children while maintaining a healthy and safe environment.
- Monitor and assist students.
- Squat, crouch or sit on small chairs low to the ground or hard floors.
- Demonstrate understanding, patient and receptive attitude toward students and staff.
- Work confidentially with discretion and independently with little supervision.
- Communicate clearly and concisely, both orally and in writing.
- Establish and maintain cooperative and effective working relationships with others.
- Perform routine clerical duties.
- Lift and move items weighing up to 50 pounds.

Education/Training/Licenses/Experience:

1. Graduation from high school or its equivalent. Must successfully pass the District's local assessment test.
2. 24 college level units, 12 of which need to be in Early Childhood Education, Child Development, or related field.
3. At least one year of experience working with children in a child development program or equivalent.

PHYSICAL STANDARDS AND WORKING CONDITIONS:

The physical and mental demands and work environment described here are representative of those that must be met by employees to successfully perform the essential functions of this class. Reasonable accommodations may be made to enable individuals with disabilities to perform the essential functions. These physical demands are generic in nature and tasks may vary dependent on specific trade and or specialized work assignment.

Physical Demands:

Physical demands of this position include sitting and standing for extended periods. The employee may frequently move or lift children weighing up to 50 pounds unassisted. Occasional bending at the waist is required, as is kneeling, crouching, squatting, pushing and pulling. Employees may reach overhead as well as above the shoulders and horizontally.

Mental Demands:

Employee must be able to comprehend and follow written and oral instructions; interpret policies and procedures; and interact cooperatively with District staff, parents, and the public.

Work Environment:

While performing the duties of this job, the employee works in several environments including classroom, indoor and outdoor environments and on or near student playground equipment.

The information contained in the physical standards description is for compliance with ADA and is not an exhaustive list of duties performed. Individuals who hold this position may perform additional duties and additional duties may be assigned.

WORK PERIOD:

10 months per year, 5 days per week, up to 3.75 hours/day

HEALTH TECHNICIAN



Classified Salary Schedule
Range 16

JOB SUMMARY:

Under direct supervision, performs a variety of clerical work of average difficulty including word processing, data entry, and other general office duties and performs related duties as required.

ESSENTIAL FUNCTIONS:

The duties listed below are intended only as illustrations of the various types of work that may be performed. The omission of specific statements of duties does not exclude them from the position if the work is similar, related, or a logical assignment to the class.

- Administers first aid and contacts appropriate emergency assistance and routine first aid procedures; attends to sick and injured students as necessary and administers medication according to physician's instructions and in accordance with the Education Code.
- May perform specialized physical health care services including, but not limited to, insulin and/or glucagon administration, catheterization, gastrostomy feeding, suctioning, ostomy care, postural drainage, and tracheotomy care, in accordance to training and supervision by the district school nurse.
- Assists the District's credentialed school nurse with routine health testing programs including, vision, dental, health, and hearing screening.
- May administer various forms of medication upon prior parental/physician authorization.
- Performs general medical/clerical work, records various types of data, and maintains confidential records.
- Maintains school health office, including keeping records of first aid supplies and ordering as needed.
- May assist parents in the completion of health records and forms and explains basic aspects of various health programs and required immunizations; follows up on student health records to assure compliance with State laws.
- May participate in workshops and in-services as required. Checks for lice on an as needed basis. Performs other related duties as assigned.
- Performs a variety of clerical tasks, including word-processing, data entry, proofreading, filing, and the recording of information. Checks and reviews a variety of data for completeness and conformance with established regulations and procedures.
- Answers the telephone and responds accordingly with routine information and data.
- Makes appointments and receives visitors by answering routine inquiries, providing them with information and data, and by directing them to the appropriate office.
- Provides information regarding school matters over the counter and by telephone.
- Compiles information and prepares reports and summaries.
- Performs other related duties as assigned.

QUALIFICATION GUIDELINES:

Knowledge of:

- Diabetes Management
- First Aid techniques and practices
- General needs and behavior of children, including basic elements of child growth and development
- Basic aspects of various health programs and equipment; health and safety regulations
- Operation of standard office equipment, including a computer, typewriter, and copy machine
- Proper English usage and communication skills
- Telephone etiquette
- Appropriate safety precautions and procedures.
- Modern office practices and procedures, including filing systems, telephone techniques and etiquette.
- Record keeping and methods of collecting and organizing data and information.
- Correct English usage, grammar, spelling, and proofreading.
- Oral and written communication skills and interpersonal skills using tact, patience and courtesy.
- General knowledge of modern office equipment and computer programs.

Ability to:

- Administer First Aid and CPR
- Understand and follow oral and written instructions
- Remain calm in emergency situations
- Analyze situations accurately
- Make good judgments and work independently with minimal supervision, meeting schedules and time lines.
- Maintain confidentiality
- Learn specialized physical health care services
- Deal effectively with students, staff and parents
- Efficiently prioritize and organize job responsibilities.
- Operate standard office machines including a computer using presentation, word processing, spreadsheet, and database software applications.
- Understand, interpret, explain, and apply school and District policies and procedures.
- Communicate clearly and effectively, both orally and in writing, with administrators, students, staff, parents and the public.
- Establish and maintain cooperative and effective working relationships with others.

Education/Training/Experience:

Some previous experience working with children in an educational, health care or child care setting, or any combination of training and experience that could likely provide the desired knowledge and abilities; high school diploma or its equivalent; some experience in a medical setting and one year clerical experience preferred; First Aid and CPR Certification desirable

Licenses/Certificates/Special Requirements:

A valid California Driver's License and the ability to maintain insurability under the District's Vehicle Insurance Policy.

PHYSICAL STANDARDS AND WORKING CONDITIONS:

The physical and mental demands and work environment described here are representative of those that must be met by employees to successfully perform the essential functions of this class. Reasonable accommodations may be made to enable individuals with disabilities to perform the essential functions. These physical demands are generic in nature and tasks may vary dependent on specific trade and or specialized work assignment.

Physical Demands:

Ability to lift up to 50 pounds without assistance, and be physically able to assist students who may have physical disabilities. Dexterity of hands and fingers to work with students. Standing or sitting for an extended period of time. Reaching overhead, above the shoulders and horizontally to work with and assist students. Some walking and standing on various surfaces as well as bending and reaching at the waist, below and above shoulder level, kneeling, and crouching. Repetitive use of fingers and hands to operate a keyboard and other office equipment is necessary; hearing and speaking ability sufficient to provide information via phone, intercom and personal contact is also needed. Specific vision abilities including close vision, depth perception and the ability to focus are required in order to read materials and assist students.

Work Environment:

While performing the duties of this job the employee works in several environments including a school office, classroom, indoor and outdoor environments and on or near student playground equipment as needed. The employees' primary responsibility is working with students in the health office. Employees in this position may have a higher level of exposure to infection and physical injury from students. This position may also involve the following: frequent interruption and direct contact with staff and the public; a high volume of responsibilities that may require working without direct and/or constant supervision; and working in a school office environment where the noise level is usually moderate.

The information contained in the physical standards description is for compliance with ADA and is not an exhaustive list of duties performed. Individuals who hold this position may perform additional duties and additional duties may be assigned.

WORK PERIOD:

10 months per year, 5 days per week, 3.75 hours per day

Health Technician-sb

Board Approved: To be approved August 8, 2022

Revised: July 2022

Reviewed: June 2022



LOWELL JOINT SCHOOL DISTRICT

LICENSED VOCATIONAL NURSE

Classified Salary Schedule
Range 23

JOB SUMMARY:

Under the general oversight of the Director of Special Education, and the supervision of the credentialed school nurse and consistent with licensing requirements, applicable laws and regulations, provides a variety of health services to students; maintains health records, referrals and reports; administers routine first-aid, assists in screening ill, injured, and medically fragile students in accordance with State law and District regulations; and with health testing programs and other health related services as required.

ESSENTIAL FUNCTIONS:

The duties listed below are intended only as illustrations of the various types of work that may be performed. The omission of specific statements of duties does not exclude them from the position if the work is similar, related, or a logical assignment to the classification.

- Performs and administers routine first aid procedures; attends to sick and injured students.
- Provides support for regular check-in and preventive support services for the needs of foster youth, adopted, homeless or McKinney Vento students.
- Performs specialized physical health care services including, but not limited to, blood glucose testing, catheterization, gastrostomy feeding, suctioning, ostomy care, postural drainage, and tracheotomy care, under the supervision of the credentialed school nurse.
- Maintains a variety of health related records both manual and electronic (e.g. confidential student health records, emergency medical records, accident reports, health & disability records, medication records, etc.) for the purpose of providing information required by regulatory requirements.
- Assists the District's credentialed school nurse with routine health testing programs including, vision, dental, health, and hearing screening, for the purpose of coordinating screenings, contacting parents and recording results of screenings
- Administer various forms of medication upon prior parental/physician authorization.
- Performs general medical/clerical work, records various types of data, maintains confidential records.
- Assists parents in the completion of health records and forms and explains basic aspects of various health programs and required immunizations; follows up on student health records to assure compliance with State laws.
- Assists students when necessary with daily living self-care skills, including diapering, toileting, feeding and other self-help skills.
- Contacts parents regarding student's health or emotional needs.
- May participate in workshops and in-services as required.
- Attends specialized trainings to help support foster youth, adopted, homeless or McKinney Vento students
- Performs other related duties as assigned.

QUALIFICATION GUIDELINES:

Knowledge of:

- First Aid practices and health and safety regulations
- Appropriate safety precautions and procedures
- Needs of medically fragile students
- Correct medical procedures for specialized health needs
- General needs and behavior of children, including basic elements of child growth and development
- Basic aspects of various health programs and equipment

- General knowledge of Modern office equipment and computer software programs such as word processing and database entry
- Modern office practices and procedures, including filing systems, telephone techniques and etiquette
- Record keeping and methods of collecting and organizing data and information
- Correct English usage, grammar, spelling and proofreading
- Oral and written communication skills

Ability to:

- Administer First Aid and CPR to ill or injured students
- Organize and perform duties with a minimum of supervision
- Remain calm in emergency situations
- Analyze situations accurately
- Make good judgments without immediate supervision
- Maintain confidentiality
- Learn specialized physical health care services
- Efficiently prioritize and organize job responsibilities.
- Communicate clearly and effectively, both orally and in writing, with students, staff, parents and the public
- Use interpersonal techniques with tact, patience and courtesy
- Maintain reliable, consistent, punctual regular attendance

Education/Training/Experience:

High school diploma or its equivalent. Some previous nursing experience in a hospital, clinic, or school environment, preferably including experience in dealing with preschool and school age children. Must have valid California Licensed Vocational Nurse license, First Aid Certification and a CPR Certification before start of employment. Valid California Driver's License.

PHYSICAL STANDARDS AND WORKING CONDITIONS:

The physical and mental demands and work environment described here are representative of those that must be met by employees to successfully perform the essential functions of this class. Reasonable accommodations may be made to enable individuals with disabilities to perform the essential functions. These physical demands are generic in nature and tasks may vary dependent on specific trade and or specialized work assignment.

Physical Demands:

Ability to lift up to 50 pounds without assistance, and be physically able to assist students who may have physical disabilities. Dexterity of hands and fingers to work with students. Standing or sitting for an extended period of time. Reaching overhead, above the shoulders and horizontally to work with and assist students. Some walking and standing on various surfaces as well as bending and reaching at the waist, below and above shoulder level, kneeling, and crouching. Repetitive use of fingers and hands to operate a keyboard and other office equipment is necessary; hearing and speaking ability sufficient to provide information via phone, radio, intercom and personal contact is also needed. Specific vision abilities including close vision, depth perception and the ability to focus are required in order to read materials and assist students.

Work Environment:

While performing the duties of this job the employee works in several environments including a school office, classroom, indoor and outdoor environments and on or near student playground equipment as needed. Employees in this position may have a higher level of exposure to infection and physical injury from students. This position may also involve the following: frequent interruption and direct contact with staff and the public; a high volume of responsibilities that may require working without direct and/or constant supervision; and working in a school office environment where the noise level is usually moderate.

The information contained in the physical standards description is for compliance with ADA and is not an exhaustive list of duties performed. Individuals who hold this position may perform additional duties and additional duties may be assigned.

WORK PERIOD: 10 months per year, 5 days per week, 8.0 hours per day

Nurse's Assistant

LOWELL JOINT SCHOOL DISTRICT
August 8, 2022

To: President Salinas and Members, Board of Trustees

From: Jim Coombs, Superintendent of Schools

Subject: Approval of Memorandum of Understanding By and
Between the Orange County Department of
Education and Lowell Joint School District for
MHSSA Partnership during the 2021 - 2024 School
Years

ACTION

The purpose of this Memorandum of Understanding (MOU) is to facilitate participation in the Mental Health Student Services Act (MHSSA) grant through a partnership with the Orange County Department of Education. The purpose of this grant is for our District to expand access to mental health services for children and youth, including campus-based mental health services. There is no cost to the District for participation.

It is recommended that the Memorandum of Understanding by and between the Orange County Department of Education and Lowell Joint School District for MHSSA Partnership during the 2021 - 2024 school years be approved and that the Superintendent or designee be authorized to execute the necessary documents.

Superintendent's Comment:

APPROVAL RECOMMENDED

LOWELL JOINT SCHOOL DISTRICT
August 8, 2022

To: President Salinas and Members, Board of Trustees

From: Jim Coombs, Superintendent of Schools

Subject: Approval of Agreement #10001508 with the Orange
County Department of Education to provide NGSS
Professional Learning during the 2022/23 School
Year

ACTION

Arrangements have been made with Orange County Department of Education to provide NGSS (Next Generation Science Standards) teacher and district support for approximately 140 staff members TK-8th during the 2022/23 school year. The cost of the training will not exceed \$2,700.00 to be paid by Educator Effectiveness funds.

It is recommended that the Agreement with Orange County Department of Education for NGSS Professional Learning during the 2022-23 school year for a total not to exceed \$2,700.00 be approved and that the Superintendent or designee be authorized to execute the necessary documents.

Superintendent's Comment:

APPROVAL RECOMMENDED.

GREAT FUTURES START HERE.



BOYS & GIRLS CLUBS
OF LA HABRA

Serving the community since 1955

MEMBER OF BOYS & GIRLS CLUBS OF AMERICA
MEMBER OF LA HABRA COMMUNITY COLLABORATIVE
MEMBER OF BOYS & GIRLS CLUBS OF ORANGE COUNTY PROFESSIONAL ASSN.
MEMBER OF BOYS & GIRLS CLUBS OF ORANGE COUNTY AREA COUNCIL

CORPORATE BOARD OF DIRECTORS

CINDY SINGER
President

*DAWN F. STILLE
Treasurer

BELINDA L. KAHN
Secretary

JACK BROWN

JOAN S. CAVANAGH

RANDY CLAYTON

MICHAEL DOWNING

HENRY ESPARZA

KATHY FELIX

RAY FERNANDEZ

*RICHARD HERMANN

JONATHAN HUGHES

*JASON JAMISON

*RICHARD JONES

*CHRISTINE KENNEDY

*WARREN KRAFT

*DAVID LITTLE

TOM MAUK

*DAVE McCAULEY

*DAREN NIGSARIAN

*KENT ROBERTS

*STEVE SIMONIAN

JANE WILLIAMS

HONORARY
BOARD MEMBERS

CARLENE COOK

CARLOS ROMO

MARK A. CHAVEZ

CPO/Executive Director

*Denotes Past Presidents

Administrative Offices
1211 Fahringer Way
La Habra, CA 90831
Phone: 562-691-2413
Fax: 562-697-0882
www.ourchildrensfuture.org
www.bgclubslahabra.com

MEMORANDUM OF UNDERSTANDING

BGC La Habra

After-School Campus Sites – Lowell Joint USD – K-6 Schools

The memorandum of Understanding is made and entered into by the Boys & Girls Clubs of La Habra and Lowell Joint School District, specifically "After-school programming in K-6 Schools in La Habra, California." This collaboration and partnership's purpose is that of recreation, enrichment, safety, educational activities. This project is consistent with the mission of the Boys & Girls Clubs of La Habra of assisting young people to positively contribute to their community. The Boys & Girls Clubs of La Habra has been involved in several collaborations and active in the community of over 67 years. This is a fee based program.

The Boys & Girls Clubs of La Habra agree to provide after school programming and educational services which include, but are not limited to:

- On-campus afterschool services from 1:30-6:00 Monday - Friday
- Community mobilization
- Snacks provided daily
- Tutoring/Homework help
- Safety & Supervision
- Enrichment
- Start August 17, 2022 – June 4, 2023

The Lowell Join School District agrees to allow Boys & Girls Clubs of La Habra personnel, director, to visit and provide services. We will work closely with the schools' teachers and keep all lines of communications open with each principal.

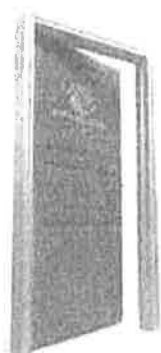

UNITS

ARBOLITA EL CERRITO EL PORTAL IMPERIAL LADERA PALMA LA HABRA
LAS LOMAS LAS POSITAS SIERRA VISTA WALNUT WASHINGTON

This Memorandum of Understanding is effective upon Lowell Joint School District approval.

Signed: Mark A. Chavez Date: 7/25/22
Mark A. Chavez
Executive Director
Boys & Girls Clubs of La Habra

Signed: Jim Coombs Date: 7/25/22
Jim Coombs
Superintendent of Schools
Lowell Joint School District

7/28/22

Addendum

Boys & Girls Clubs of La Habra addendum to the Memorandum of Understanding with the Lowell Joint Unified School District signed by Jim Coombs, Superintendent on July 25, 2022.

Starting and ending dates are August 17, 2022 – June 2, 2023

7/28/22

Addendum no. 2

Boys & Girls Clubs of La Habra addendum to the Memorandum of Understanding with the Lowell Joint Unified School District, signed by Jim Coombs, Superintendent on July 25, 2022.

Time of service for all 5 Lowell Elementary schools for 22/23 school year. Mondays, TK/Kinder are out at 1:15; on minimum days/early release TK/k dismiss at 12:40 and everyone else at 1:05

LOWELL JOINT SCHOOL DISTRICT
August 8, 2022

To: President Salina and Members, Board of Trustees

From: Jim Coombs, Superintendent of Schools

Subject: Approval of Agreement #13249 with Thinking Maps Inc. to Provide Professional Development During the 2022-23 School Year ACTION

Arrangements have been made with Thinking Maps Inc. to provide a full day of on-site Professional Development on November 1, 2022 per Agreement #13249. Kathryn Knecht, Lauren Loper, Sarah McNeil, and Leanna Brown of Thinking Maps Inc. will provide this training at a cost NTE \$8,800.00. Funding for this expenditure will be covered by Title II.

It is recommended that the agreement with Thinking Maps Inc. to provide on-site Professional Development during the 2022-23 school year at a cost of \$8,800 for Agreement #13249 be approved and that the Superintendent or designee be authorized to execute the necessary documents.

Superintendent's Comment:

APPROVAL RECOMMENDED.

X-D4-1

LOWELL JOINT SCHOOL DISTRICT
August 8, 2022

To: President Salina and Members, Board of Trustees
From: Jim Coombs, Superintendent of Schools
Subject: Approval of Agreement #13256 with Thinking
Maps Inc. to Provide Professional Development
During the 2022-23 School Year

ACTION

Arrangements have been made with Thinking Maps Inc. to provide a full day of on-site Professional Development on April 7, 2023 per Agreement #13256. Kathryn Knecht, Lauren Loper, Stefanie Hardgrave, and TBD of Thinking Maps Inc. will provide this training at a cost NTE \$10,000.00. Funding for this expenditure will be covered by Title II.

It is recommended that the agreement with Thinking Maps Inc. to provide on-site Professional Development during the 2022-23 school year at a cost of \$10,000 for Agreement #132564271 be approved and that the Superintendent or designee be authorized to execute the necessary documents.

Superintendent's Comment:

APPROVAL RECOMMENDED.

X-D5-1

