



A PROUD TRADITION | A BRIGHT FUTURE

REGULAR BOARD MEETING

Thursday, December 15, 2016

7:00 PM

James Steenbergen, President • Kathryn Kaminski, Vice President • Kay Danziger, Secretary
Anna Gonzales • Dr. Tyson Harrell • Melisa Roberts • Frank Torres

**LAMAR CISD BOARD OF TRUSTEES
REGULAR BOARD MEETING
BRAZOS CROSSING ADMINISTRATION BUILDING
3911 AVENUE I, ROSENBERG, TEXAS
DECEMBER 15, 2016
7:00 PM**

AGENDA

1. Call to order and establishment of a quorum
2. Opening of meeting
3. Recognitions/awards
4. Introductions
5. Audience to patrons
6. Approval of minutes
 - A. November 15, 2016 - Special Meeting (Workshop) 6
 - B. November 17, 2016 - Regular Board Meeting 11
7. Board members reports
 - A. Meetings and events
8. Superintendent reports
 - A. Meetings and events
 - B. Information for immediate attention
9. Public Hearing on Financial Integrity Rating System of Texas (FIRST) for fiscal year 2014 - 2015
10. **ACTION ITEMS**
 - A. **Goal: Instructional**
 1. Consider approval of out-of-state student trip requests, including but not limited to:
 - a. George Ranch High School Band 18
 - B. **Goal: Planning**
 1. Consider approval of budget amendment requests 19
 2. Consider ratification of Financial and Investment Reports 21
 3. Consider approval of an Order Authorizing the Issuance of Lamar Consolidated Independent School District Unlimited Tax Schoolhouse Bonds, Series 2017; Approving the Preparation of an Official Statement; and Enacting Other Provisions Relating Thereto 25
 4. Consider approval of Master Interlocal Agreement with Region 10 Education Service Center for products and services related to Eduphoria 65
 5. Consider approval of donations to the district, including, but not limited to: 68
 - a. Frost Elementary School
 - b. Meyer Elementary School

6. Consider approval of Board Policies	69
7. Consider approval of Attendance Boundary Committee	70
8. Consider approval of CenterPoint Energy aerial easement for Bentley Elementary School	76
9. Consider approval of Texas Education Agency code compliance review for Carter Elementary School	83
10. Consider approval of traffic study for Carter Elementary School	86
11. Consider approval of materials testing for Terry High School baseball complex renovations	90
12. Consider approval of donation deed	102
13. Consider approval of final payment for the Fulshear High School, Leaman Junior High School, and renovations to the Transportation Facility	114
14. Consider approval of revised District records retention schedule for General Records (GR), School District Records (SD), and Records of Elections and Voter Registration (EL)	116
11. INFORMATION ITEMS	
A. Goal: Communications	
1. School Board Recognition Month	117
B. Goal: Personnel	
1. Report on Board Member Training	119
C. Goal: Planning	
1. Stewardship Report	120
2. Lamar Education Awards Foundation (LEAF) Update	121
3. Tax Collection Report	122
4. Payments for Construction Projects	128
5. Bond Update	
a. 2011	131
b. 2014	139
6. Projects funded by 2011 available bond funds	152
7. Transportation Update	153
8. Maintenance and Operations vehicle purchases	155
12. CLOSED SESSION	
A. Adjournment to closed session pursuant to Texas Government Code Sections 551.071, 551.072, 551.074, and 551.082, the Open Meetings Act, for the following purposes: (Time_____)	
1. Section 551.074 - For the purpose of considering the appointment, employment, evaluation, reassignment, duties, discipline or dismissal of a public officer or employee or to hear complaints or charges against a public officer or employee.	156
a. Approval of personnel recommendations for employment of professional personnel	

- b. Employment of professional personnel (Information) 157
- c. Employee resignations and retirements (Information) 158
- d. Consider employment of Athletic Director 159
- 2. Section 551.072 - For the purpose of discussing the purchase, exchange, lease or value of real property
 - a. Land
- 3. Section 551.071 - To meet with the District's attorney to discuss matters in which the duty of the attorney to the District under the Texas Disciplinary Rules of Professional Conduct of the State Bar of Texas clearly conflicts with the Open Meetings Act, including the grievance/complaint hearing.
 - a. Any item listed on the agenda
 - b. Discuss pending, threatened, or potential litigation, including school finance litigation

RECONVENE IN OPEN SESSION

Action on Closed Session Items
Future Agenda Items
Upcoming Meetings and Events

ADJOURNMENT: (Time _____)

If during the course of the meeting covered by this notice, the Board should determine that a closed session of the Board should be held or is required in relation to an item noticed in this meeting, then such closed session as authorized by Section 551.001 et seq. of the Texas Government Code (the Open Meetings Act) will be held by the Board at that date, hour or place given in this notice or as soon after the commencement of the meeting covered by this notice as the Board may conveniently meet in such closed session concerning any and all subjects and for any and all purposes permitted by Section 551.071-551.084, inclusive, of the Open Meetings Act, including, but not limited to:

Section 551.084 - For the purpose of excluding witness or witnesses from a hearing during examination of another witness.

Section 551.071 - For the purpose of a private consultation with the Board's attorney on any or all subjects or matters authorized by law.

Section 551.072 - For the purpose of discussing the purchase, exchange, lease or value of real property.

Section 551.073 - For the purpose of considering a negotiated contract for a prospective gift or donation.

Section 551.074 - For the purpose of considering the appointment, employment, evaluation, reassignment, duties, discipline or dismissal of a public officer or employee or to hear complaints or charges against a public officer or employee.

Section 551.082 - For the purpose of considering discipline of a public school child or children or to hear a complaint by an employee against another employee if the complaint or charge directly results in a need for a hearing.

Section 551.076 - To consider the deployment, or specific occasions for implementation, of security personnel or devices.

Section 551.083 - For the purpose of considering the standards, guidelines, terms or conditions the Board will follow, or instruct its representatives to follow, in consultation with representatives of employee groups in connection with consultation agreements provided for by Section 13.901 of the Texas Education Code.

Section 551.0821 – For the purpose of deliberating a matter regarding a public school student if personally identifiable information about the student will necessarily be revealed by the deliberation.

Should any final action, final decision or final vote be required in the opinion of the Board with regard to any matter considered in such closed session, then such final action, final decision or final vote shall be at either:

- a. the open meeting covered by this notice upon the reconvening of this public meeting, or
- b. at a subsequent public meeting of the Board upon notice thereof, as the Board may determine.

CERTIFICATE AS TO POSTING OR GIVING OF NOTICE

On this 9th day of December 2016 at 3:00 p.m., this notice was posted on a bulletin board located at a place convenient to the public in the central administrative offices of the Lamar Consolidated Independent School District, 3911 Avenue I, Rosenberg, Texas 77471, and in a place readily accessible to the general public at all times.



Karen Vacek
Secretary to Superintendent

Special Meeting

Be It Remembered

The State of Texas §
County of Fort Bend §
Lamar Consolidated Independent School District §

Notice of Special Meeting Held

On this the 15th day of November 2016, the Board of Trustees of the Lamar Consolidated Independent School District of Fort Bend County, Texas met in Special Session (Workshop) in Rosenberg, Fort Bend County, Texas.

1. CALL TO ORDER AND ESTABLISHMENT OF A QUORUM

This meeting was duly called to order by the President of the Board of Trustees, Mr. James Steenbergen, at 6:30 p.m.

Members Present:

James Steenbergen	President
Kathryn Kaminski	Vice President
Kay Danziger	Secretary
Anna Gonzales	Member
Tyson Harrell	Member
Melisa Roberts	Member

Members Absent:

Frank Torres	Member
--------------	--------

Others Present:

Thomas Randle	Superintendent
Kevin McKeever	Administrator for Operations
Jill Ludwig	Chief Financial Officer
Linda Lane	Interim Executive Director of Elementary Education
Leslie Haack	Executive Director of Secondary Education
Kathleen Bowen	Chief Human Resources Officer
Mike Rockwood	Executive Director of Community Relations
Valerie Vogt	Academic Administrator

BUSINESS TRANSACTED

Business properly coming before the Board was transacted as follows: to witness—

2. Discussion of November 17th Regular Board Meeting Agenda Items

The Board reviewed the November 17th Regular Board Meeting agenda items.

Minutes of Special Board Meeting November 15, 2016 – page 17

10. ACTION ITEMS

10. A GOAL: INSTRUCTIONAL

10. A-1 Consider approval of the 2017-2018 Student Course Selection Catalog

Ms. Roberts asked if it is when the catalogs are offered to the campuses, that they choose courses based upon their staff and amount of staff they have. Ms. Haack said it is during open enrollment in January when course selection begins for the next school year. All courses are available online and the students select their courses. After Spring Break, course enrollment reports are run. Campuses then know how many students have selected certain courses. That is when they adapt the hiring and staffing to accommodate the growth. Ms. Roberts asked if we have a lot of courses that require the Distance Learning Courses where the kids and teachers are on different campuses. Ms. Haack said we do not have very many, and this year it will only be a Computer Science course. Ms. Roberts asked if feedback will be given on how these students are performing in comparison to the ones that have teachers in the classroom. Ms. Haack said yes they monitor this.

Mr. Steenbergen asked why the Texas Virtual Schools Network was removed. Ms. Haack said the service has been discontinued. He asked about courses previously listed under Public Service, and said that he found those courses distributed elsewhere. Ms. Haack said the Health Science courses moved because TEA is redoing where the courses fall in the endorsements. Mr. Steenbergen asked why Finance was removed under Business & Industry. Ms. Haack said that was probably a course discontinued by TEA and picked up with a different course title.

10. A-3 Consider updates to board policy EIC (LOCAL) related to GPA and class rank provisions

Ms. Danziger asked when the changes will take place. Ms. Haack said this is for our current juniors and beyond.

10. B GOAL: PLANNING

10. B-3 Consider approval of districtwide department process audit

Mr. Steenbergen asked what is the source of funding for this item. Ms. Ludwig said it is from the general fund by budget amendment.

Ms. Kaminski asked if this will include special education or if that an extra expense. Mr. Steenbergen said it was not included in this amount. Ms. Kaminski asked if they should anticipate an increase in the amount. Mr. Steenbergen said yes if the Board chooses to put special education in the audit.

10. B-8 Consider approval of design development for the band hall expansion at Terry High School

Dr. Harrell said he appreciated the alternate bid for the drop off zone. He asked if there are any other features the staff wanted. Mr. Hoyt said they would love a bigger space, this is currently sized for about 35 students. However, based on the budget, this is the largest they can make the band hall.

Minutes of Special Board Meeting November 15, 2016 – page 18

Mr. Steenbergen asked why it cost \$500 per square foot, when you can build an elementary school for more like \$200 per square foot. Mr. Hoyt said it is because it is a small project, primarily high volume space in a small area.

Ms. Danziger asked if the Lamar Consolidated High School expansion is in the existing parking lot. Mr. Kunz said yes it is. Some of the parking places will be recaptured by closing off another area.

Mr. Steenbergen asked what the possible cost of the loading drive might be. Mr. Kunz said right now they have estimated around \$30,000.

11. INFORMATION ITEMS

11. A GOAL: INSTRUCTIONAL

11. A-1 College-Readiness testing report, 2015-2016

Mr. Brian Moore presented to the Board.

Ms. Roberts asked if the percent of students that passed actually decreased. Mr. Moore said slightly by 2%. Ms. Roberts asked about the increase of students that actually took the course. Mr. Moore said approximately 20%. Dr. Harrell said overall more kids passed, but it was because more were encouraged to take the course.

Ms. Roberts asked if the SAT is for seniors in the spring. Mr. Moore said it started with juniors. Ms. Danziger asked if we pay for the students to take the test. Mr. Moore said yes, and that for the SAT School Day the District pays the cost. The District receives a substantial discount and helps the students in taking a qualifying test and increases the number of students who become prepared for post-secondary readiness. Ms. Roberts asked if students can use this test as the only one to take. Mr. Moore said if they score high enough, yes. Ms. Roberts asked if they get this option with the ACT. Mr. Moore said just the SAT.

Ms. Gonzales asked if we are encouraging the kids that are in intermediate and junior high schools to take the AP classes. Mr. Moore said yes. Ms. Vogt said they identify the students early by running profiles for the principals. Ms. Gonzales asked what qualifies a student to take AP classes. Ms. Vogt said it is open enrollment for anyone. They work with the parents and students to inform them and get a commitment to take AP classes.

Mr. Steenbergen said he still has a little disconnect. He said he would have expected if we are targeting the students and they have the capability that we would not have seen a decrease in passing rate even though we increased the number taking the exam. Ms. Vogt said if they are in an AP course, they are encouraged to take the exam. The students were not picked according to if we thought they would pass the test. She explained that just taking that AP exam is an education in itself. It helps prepare them for the types of exams they will take when they go into college level classes.

Ms. Roberts said this is a common question that she personally experienced. Students at a younger age can take AP courses and because of their lack of experience, a lot of them went in and did not pass with a 3 or above. But the experience was outside of anything that had ever done before. Those students are

Minutes of Special Board Meeting November 15, 2016 – page 19

young and may not have been successful this year, but they will be more prepared in the future.

Ms. Gonzales asked about the 6th graders who choose to take PAP courses and are not doing well. She asked if they are being discouraged to enroll in general classes after PAP classes. Ms. Vogt said no, part of the information to the parents is that it is better to make a “C” in rigorous course than an “A” in an easy class.

11. B GOAL: PLANNING

11. B-1 Board Policies for First Reading

Mr. Steenbergen asked about where EHBAF (LOCAL) talks about the people who can actually hear the confidential recordings, and that if it is escalated to the Board it does not say the Trustees would be able to review these. Dr. Randle said that not many of these have been escalated to the Board. Special Education has different routes that are normally taken. He said he would have the Executive Director clarify.

Mr. Steenbergen asked about CDC (LOCAL) and why are they changing to \$5,000 and why quarterly for donations. Ms. Ludwig said it is mainly for efficiency. The capitalization threshold is \$5,000.

Ms. Roberts asked about DK (LOCAL) in regards to parent notification on classrooms. Dr. Bowen said with the changing of NCLB, there is state criteria that supersedes parent notifications. Ms. Roberts has a concern about those courses especially in Junior High School where students are taking courses that affect their GPA and are not being taught by a certified teacher. She feels parents need to be notified sooner, primarily because they count towards their GPA. Dr. Bowen said FMLA notifications are sent out when the teacher goes out, unless it is an emergency.

11. B-4 Tax Collection Report

Mr. Steenbergen asked about the 2015 and prior years collection rate of 23.24%, he wanted to know what is our probability of getting the rest of this money. Ms. Ludwig said that the budget is based on historical trends, so very good.

11. B-9 Energy Management Report

Mr. Steenbergen asked Mr. McKeever how many times the Board has asked about this report. He then went on to say that this might be a report that will be removed.

3. AUDIENCE TO PATRONS

None

ADJOURNMENT TO CLOSED SESSION PURSUANT TO TEXAS GOVERNMENT CODE SECTIONS 551.071, 551.072, 551.074, and 551.082, THE OPEN MEETINGS ACT, FOR THE FOLLOWING PURPOSES:

1. Section 551.074 – For the purpose of considering the appointment, employment, evaluation, reassignment, duties, discipline or dismissal of a public officer or employee or to hear complaints or charges against a public officer or employee.

Minutes of Special Board Meeting November 15, 2016 – page 20

- a. Approval of personnel recommendations for employment of professional personnel
- b. Employment of professional personnel (Information)
- c. Employee resignations and retirements (Information)
2. Section 551.072 – For the purpose of discussing the purchase, exchange, lease or value of real property
 - a. Land
3. Section 551.071 – To meet with the District's attorney to discuss matters in which the duty of the attorney to the District under the Texas Disciplinary Rules of Professional Conduct of the State Bar of Texas clearly conflicts with the Open Meetings Act, including the grievance/complaint hearing.
 - a. Any item listed on the agenda
 - b. Discuss pending, threatened, or potential litigation, including school finance litigation

The Board did not convene in Closed Session.

ADJOURNMENT

The meeting adjourned at 7:19 p.m.

LAMAR CONSOLIDATED INDEPENDENT SCHOOL DISTRICT

Signed:

James Steenbergen
President of the Board of Trustees

Kay Danziger
Secretary of the Board of Trustees

Regular Meeting

Be It Remembered

The State of Texas §
County of Fort Bend §
Lamar Consolidated Independent School District §

Notice of Regular Meeting Held

On this the 17th day of November 2016, the Board of Trustees of the Lamar Consolidated Independent School District of Fort Bend County, Texas met in Regular Session in Rosenberg, Fort Bend County, Texas.

1. CALL TO ORDER AND ESTABLISHMENT OF A QUORUM

This meeting was duly called to order by the President of the Board of Trustees, Mr. James Steenbergen, at 7:00 p.m.

Members Present:

James Steenbergen	President
Kay Danziger	Secretary
Anna Gonzales	Member
Tyson Harrell	Member
Melisa Roberts	Member

Members Absent:

Kathryn Kaminski	Vice President
Frank Torres	Member

Others Present:

Thomas Randle	Superintendent
Kevin McKeever	Administrator for Operations
Jill Ludwig	Chief Financial Officer
Linda Lane	Interim Executive Director of Elementary Education
Leslie Haack	Executive Director of Secondary Education
Kathleen Bowen	Chief Human Resources Officer
Mike Rockwood	Executive Director of Community Relations
David Jacobson	Chief Technology Information Officer
Michelle Morris	Attorney

BUSINESS TRANSACTED

Business properly coming before the Board was transacted as follows: to witness—

2. OPENING OF MEETING

A moment of silence was observed and the pledge of allegiance was recited.

3. STUDENT REPORTS

a. Authors in the Classroom

The following 4th grade students in Ms. Cruikshak's class from Jane Long Elementary School talked about their interaction with a New York Times author:

Cesar Alanis
Leah Rebecca Almazan
Lana Garza
Adrian Riley
Ariana Alas

4. RECOGNITIONS/AWARDS

Mr. Steenbergen recognized LEAF and the fact they distributed almost \$350,000 today.

5. INTRODUCTIONS

None

6. AUDIENCE TO PATRONS

None

7. APPROVAL OF MINUTES

A. October 18, 2016 SPECIAL MEETING (WORKSHOP)

It was moved by Ms. Danziger and seconded by Ms. Gonzales that the Board of Trustees approve the minutes of October 18, 2016 Special Meeting (Workshop). The motion carried unanimously.

B. October 20, 2016 REGULAR BOARD MEETING

It was moved by Ms. Gonzales and seconded by Ms. Roberts that the Board of Trustees approve the minutes of October 20, 2016 Regular Board Meeting. The motion carried unanimously.

8. BOARD MEMBER REPORTS

a. Meetings and Events

Ms. Danziger reported the Technology Committee met. She reported the status of projects going on throughout the District. She also reported the Facilities Committee met, and reported the status of projects going on throughout the District. She said that LEAF in 17 years is only \$72,000 short of \$3m that has been distributed to our staff. She also said that today every school received at least one grant. She participated in the Lunches of Love walk on Saturday, where they raised \$56,000. She said this will cover 32,000 weekend care packages which will be about 16 weeks. She wanted to note that the LCISD Bus Babes were there in full attendance.

Mr. Steenbergen attended a TxDOT meeting about the expansion of Crabb River Road. He said it will be 2017 before they start this work and the overpass at the railroad tracks

Minutes of Regular Board Meeting November 17, 2016 – page 23

has been designed but has not been funded. He and Ms. Danziger attended the Gulf Coast Area Association of School Boards meeting.

9. SUPERINTENDENT REPORTS

a. Meetings and Events

Dr. Randle reported that they had Student Advisory meetings, where 48 students from all color tracks were in attendance.

On December 9th, Brazos Crossing will transform into Whoville and the Seguin Early Childhood students will come for a field trip.

b. Information for Immediate Attention

ACTION ITEMS FOR CONSENT OF APPROVAL: 10. A-1 – 10. A-4; 10. B-1 – 10. B-16; and 10. C-1

It was moved by Ms. Danziger and seconded by Dr. Harrell that the Board of Trustees approve these action items as presented. The motion carried unanimously.

10. A GOAL: INSTRUCTIONAL

10. A-1 Approval of the 2017-2018 Student Course Selection Catalog

Approved the 2017-2018 Student Course Selectin Catalog.

10. A-2 Approval of district instructional materials adoption committee

Approved the District Instructional Materials Adoption Committee members as submitted.

10. A-3 Updates to board policy EIC (LOCAL) related to GPA and class rank provisions

Approved the revision of EIC (LOCAL) to clarify the calculation of GPA and Class Rank related to students graduating under the current four-by-four structure and the new House Bill 5 endorsement structure. (See inserted pages 23- A – 23-D.)

10. A-4 Approval of out-of-state student trip requests, including but not limited to:

a. George Ranch High School Choir

Approved the out-of-state travel for the George Ranch High School Choir to travel to New York City, New York, to participate in a Broadway in the Classroom Clinic on April 20-23, 2017.

b. George Ranch High School Speech and Debate Team

Approved the out-of-state travel for George Ranch High School Speech and Debate team to travel to Cambridge, Massachusetts, to compete in the Harvard Speech and Debate Tournament on February 10–13, 2017.

Minutes of Regular Board Meeting November 17, 2016 – page 24

10. B GOAL: PLANNING

10. B-1 Approval of budget amendment requests

Approved budget amendment requests as attached. (See inserted page 24-A.)

10. B-2 Ratification of Financial and Investment Reports

Ratified the Financial and Investment Reports as presented.

10. B-3 Approval of districtwide department process audit

Approved McConnell & Jones, LLP for the districtwide department process audit in the amount of \$217,956, approve budgetary amendments as necessary, and authorized the Board President to execute the agreement.

10. B-4 Approval of donations to the district, including, but not limited to:

- a. Campbell Elementary School
- b. Common Threads

Approved donations to the District.

10. B-5 Approval of moving services for Bentley Elementary School

Approved Roadrunner Moving & Storage for providing staff and moving supplies for Bentley Elementary in the amount of \$1,690 and authorized the Board President to execute the agreement. (See inserted pages 24-B – 24-C.)

10. B-6 Approval of geotechnical study for the Terry High School baseball complex renovations

Approved Terracon, Inc. for the geotechnical study for the Terry High School baseball complex renovations in the amount of \$700 and authorized the Board President to execute the agreement. (See inserted pages 24-D – 24-E.)

10. B-7 Approval of design development for the band hall expansion at Lamar Consolidated High School

Approved the design development for the band hall expansion at Lamar Consolidated High School, as presented by VLK Architects.

10. B-8 Approval of design development for the band hall expansion at Terry High School

Approved the design development for the band hall expansion at Terry High School, as presented by VLK Architects.

10. B-9 Approval of geotechnical study for the Foster High School water plant upgrades

Approved Terracon, Inc. for the geotechnical study for the Foster High School water plant upgrades in the amount of \$4,100 and authorized the Board President to execute the agreement. (See inserted pages 24-F – 24-L.)

Minutes of Regular Board Meeting November 17, 2016 – page 25

10. B-10 Approval of pollution hazard survey for the Foster High School water plant upgrades

Approved HVJ Associates, Inc. for the pollution hazard survey for the Foster High School water plant upgrades in the amount of \$4,350 and authorized the Board President to execute the agreement. (See inserted pages 25-A – 25-B.)

10. B-11 Approval of CSP #03-2017VRG for the replacement chillers

Approved American Mechanical Services, LLC for the construction of the replacement chillers in the amount of \$970,800 and authorized the Board President to execute the agreement.

10. B-12 Approval of the districtwide site lighting service order for KCI

Approved the service order for KCI Technologies for districtwide site lighting in the amount of 6% of the total construction cost plus additional services and authorized the Board President to execute the agreement. (See inserted pages 25-C – 25-F.)

10. B-13 Approval of out-of-district MUD agreement for Bentley Elementary School and Agricultural Barn #2

Approved the out-of-district agreement with Fort Bend County MUD No. 142 for Bentley Elementary School and Agricultural Barn #2 and authorized the Board President to execute the agreement. (See inserted pages 25-G – 25-W.)

10. B-14 Approval of encroachment agreement for Huggins Elementary School driveway improvements

Approved the encroachment agreement with Copano NGL Services LLC for Huggins Elementary School driveway improvements and authorized the Board President to execute the agreement. (See inserted pages 25-X – 25-BB.)

10. B-15 Approval of donation deed

Approved the donation deed of 0.1088 acres to Fort Bend County for the deceleration lane on FM 1093 and authorized the Board President to execute the agreement. (See inserted pages 25-CC – 25-LL.)

10. B-16 Approval of final payment for the Williams Elementary water line and forced main connections

Approved the final payment of \$30,079.86 to Joslin Construction for the construction of the Williams Elementary water line and forced main project.

10. C GOAL: TECHNOLOGY

10. C-1 Approval of districtwide interactive whiteboard buildout

Approved the interactive whiteboard buildout project Phase II in the amount of \$112,308.62 for hardware, services, and supplies, and authorized the Superintendent to execute the agreements.

11. INFORMATION ITEMS

11. A GOAL: INSTRUCTIONAL

11. A-1 College-Readiness testing report, 2015-2016

11. B GOAL: PLANNING

11. B-1 Board Policies for First Reading

11. B-2 Parent Involvement Update

11. B-3 Program Grant to Foster High School

11. B-4 Tax Collection Report

11. B-5 Payments for Construction Projects

11. B-6 Bond Update

a. 2011

b. 2014

11. B-7 Projects funded by 2011 available bond funds

11. B-8 Transportation Update

11. B-9 Energy Management Report

Mr. Steenbergen asked for consensus from the Board to remove this report. They all agreed.

ADJOURNMENT TO CLOSED SESSION PURSUANT TO TEXAS GOVERNMENT CODE SECTIONS 551.071, 551.072, 551.074, and 551.082, THE OPEN MEETINGS ACT, FOR THE FOLLOWING PURPOSES:

1. Section 551.074 – For the purpose of considering the appointment, employment, evaluation, reassignment, duties, discipline or dismissal of a public officer or employee or to hear complaints or charges against a public officer or employee.
 - a. Approval of personnel recommendations for employment of professional personnel
 - b. Employment of professional personnel (Information)
 - c. Employee resignations and retirements (Information)
2. Section 551.072 – For the purpose of discussing the purchase, exchange, lease or value of real property
 - a. Land
3. Section 551.071 – To meet with the District’s attorney to discuss matters in which the duty of the attorney to the District under the Texas Disciplinary Rules of Professional Conduct of the State Bar of Texas clearly conflicts with the Open Meetings Act, including the grievance/complaint hearing.
 - a. Any item listed on the agenda
 - b. Discuss pending, threatened, or potential litigation, including school finance litigation

Minutes of Regular Board Meeting November 17, 2016 – page 27

The Board did not convene in Closed Session.

FUTURE AGENDA ITEMS

None

UPCOMING MEETINGS AND EVENTS

Leaman Junior High and Fulshear High School dedication is on December 2nd at 10 a.m.
Whoville will be at Brazos Crossing on December 9th at 9 a.m.

ADJOURNMENT

The meeting adjourned at 7:26 p.m.

LAMAR CONSOLIDATED INDEPENDENT SCHOOL DISTRICT

Signed:

James Steenbergen
President of the Board of Trustees

Kay Danziger
Secretary of the Board of Trustees

CONSIDER APPROVAL OF OUT-OF-STATE STUDENT TRIP REQUESTS

RECOMMENDATION:

That the Board of Trustees approve out-of-state travel for the George Ranch High School Band to travel to Orlando, Florida from June 4-10, 2017.

IMPACT/ RATIONALE:

The George Ranch High School Band requests to travel to Orlando, Florida from June 4 - 10, 2017 by charter bus. The estimated cost for each student and chaperone will be approximately \$1,250 (based on quad occupancy). This cost includes four nights lodging, daily meals per student/chaperone, admission to the Disney and Universal theme parks, and ground transportation. All costs will be covered by individuals attending and fundraisers to be held. Anticipated number of students attending will be 104, four directors, and 12 parent chaperones. The George Ranch Band will march at one of the Disney Theme Parks, and participate in Disney's "You're Instrumental" Recording Clinic as part of the Disney Magic Music Days educational performance program.

BACKGROUND INFORMATION:

This will be the second out-of-state travel for the George Ranch High School Band. They traveled to Orlando, Florida in June, 2013.

Submitted by: Leslie Haack, Executive Director of Secondary Education
Ramiro Estrada, Director of Fine Arts

Recommended for approval:



Dr. Thomas Randle
Superintendent

CONSIDER APPROVAL OF BUDGET AMENDMENT REQUESTS

RECOMMENDATION:

That the Board of Trustees consider approval of budget amendment requests as attached.

IMPACT/RATIONALE:

The proposed budget amendments require school board approval because budgeted funds are being reallocated between functional categories and/or new budgets are being established.

PROGRAM DESCRIPTION:

Budget amendments are mandated by the state for budgeted funds reallocated from one functional level, and state and/or federal project to another. These budget changes are usually the result of unexpected levels of expenditures in certain categories and amendments are for legal compliance. Other budget amendments are determined by the School board.

Since the operating budget for Lamar CISD is adopted at the functional level, budget revisions are required for reallocations between functional levels or when new budgets are being established. All necessary budget amendments must be formally adopted by the School Board and recorded in the Board minutes. (TEA Financial Accountability System Resource Guide, Financial Accounting & Reporting, Update 15.0)

Submitted by: Jill Ludwig, CPA, RTSBA, Chief Financial Officer
Yvonne Dawson, RTSBA, Budget and Treasury Officer

Recommended for approval:



Dr. Thomas Randle
Superintendent

Leaman Junior High is requesting two budget changes:

The first budget change is to pay for the band teacher to attend the Texas Music Educators Association Conference in San Antonio, Texas.

199-36	Cocurricular/Extracurricular Activities	(500.00)
199-13	Curriculum and Instr. Staff Development	500.00

The second budget change is to purchase instructional supplies for band.

199-36	Cocurricular/Extracurricular Activities	(400.00)
199-11	Classroom Instruction	400.00

CONSIDER RATIFICATION OF FINANCIAL AND INVESTMENT REPORTS

RECOMMENDATION:

That the Board of Trustees ratify the Financial and Investment Reports as presented.

PROGRAM DESCRIPTION:

Financial reporting is intended to provide information useful for many purposes. The reporting function helps fulfill government's duty to be publicly accountable, as well as to help satisfy the needs of users who rely on the reports as an important source of information for decision making.

Financial reports and statements are the end products of the accounting process. You will find attached the following reports:

- Ratification of November 2016 Disbursements, all funds
 - List of disbursements for the month by type of expenditure
- Financial Reports
 - Year-to-Date Cash Receipts and Expenditures, General Fund only
 - Investment Report

Submitted by: Jill Ludwig, CPA, RTSBA, Chief Financial Officer
 Michele Reynolds, CPA, Director of Finance

Recommended for ratification:

Dr. Thomas Randle
Superintendent

SCHEDULE OF NOVEMBER 2016 DISBURSEMENTS

IMPACT/RATIONALE:

All disbursements made by the Accounting Department are submitted to the Board of Trustees for ratification on a monthly basis. Disbursements made during the month of November total \$35,405,414 and are shown below by category:

<u>3-Digit Object</u>	<u>Description</u>	<u>Disbursements</u>
611/612	Salaries and Wages, All Personnel	15,888,469
614	Employee Benefits	743,598
621	Professional Services	16,105
623	Education Services Center	1,700
624	Contracted Maintenance and Repair Services	376,374
625	Utilities	126,031
626	Rentals and Operating Leases	780,109
629	Miscellaneous Contracted Services	353,931
631	Supplies and Materials for Maintenance and Operations	412,732
632	Textbooks and Other Reading Materials	579,896
633	Testing Materials	765
634	Food Service	617,079
639	General Supplies and Materials	4,395,477
641	Travel and Subsistence -- Employee and Student	122,988
642	Insurance and Bonding Costs	39,335
649	Miscellaneous Operating Costs/Fees and Dues	78,984
659	Other Debt Services Fees	500
661	Land Purchase and/or Improvements	30,450
662	Building Purchase, Construction, and/or Improvements	6,053,521
663	Furniture & Equipment - \$5,000 or more per unit cost	4,762,683
129	Misc. Receivable/Alternative Certification Fees	4,000
131	Inventory Purchases	16,331
573/575/592	Miscellaneous Refunds/Reimbursements to Campuses	4,356
	Total	35,405,414

PROGRAM DESCRIPTION:

The report above represents all expenditures made during the month of November 2016. The detailed check information is available upon request.

Submitted by,



Michele Reynolds,
Director of Finance

Recommended for approval:

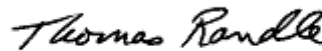

Dr. Thomas Randle
Superintendent

**LAMAR CONSOLIDATED I.S.D.
GENERAL FUND
YEAR TO DATE CASH RECEIPTS AND EXPENDITURES
(BUDGET AND ACTUAL)
AS OF NOVEMBER 30, 2016**

CASH RECEIPTS	AMENDED BUDGET	ACTUAL	BUDGET VARIANCE	PERCENT ACTUAL/ BUDGET
5700-LOCAL REVENUES	147,829,278.00	4,193,622.00	(143,635,656.00)	2.8%
5800-STATE PROGRAM REVENUES	97,669,179.00	56,768,298.00	(40,900,881.00)	58.1%
5900-FEDERAL PROGRAM REVENUES	1,725,000.00	42,879.00	(1,682,121.00)	2.5%
7900- OTHER RESOURCES	-	192,187.00	192,187.00	
TOTAL- REVENUES	247,223,457.00	61,196,986.00	(186,026,471.00)	24.8%
EXPENDITURES				
6100-PAYROLL COSTS	207,682,712.00	52,974,560.00	154,708,152.00	25.5%
6200-PROFESSIONAL/CONTRACTED SVCS.	23,875,896.00	3,960,927.00	19,914,969.00	16.6%
6300-SUPPLIES AND MATERIALS	12,370,392.00	2,519,967.00	9,850,425.00	20.4%
6400-OTHER OPERATING EXPENDITURES	5,054,390.00	1,014,760.00	4,039,630.00	20.1%
6600-CAPITAL OUTLAY	1,781,031.00	277,193.00	1,503,838.00	15.6%
TOTAL-EXPENDITURES	250,764,421.00	60,747,407.00	190,017,014.00	24.2%

Lamar CUSD
Local Investment Pools
as of November 30, 2016

ACCOUNT NAME	BEGINNING BALANCE	TOTAL DEPOSIT	TOTAL WITHDRAWAL	TOTAL INTEREST	MONTH END BALANCE
TexPool accounts are as follows:					
Food Service	2,820,469.77	0.00	300,000.00	835.31	2,521,305.08
General Account	82,181,989.94	0.00	20,648,750.00	24,088.88	61,557,328.82
Health Insurance	7,200,678.15	1,260,416.67	2,250,000.00	2,326.29	6,213,421.11
Workmen's Comp	430,492.40	38,333.33	60,000.00	142.72	408,968.45
Property Tax	583,850.48	2,462,853.70	0.00	415.24	3,047,119.42
Vending Contract Sponsor	476,947.59	0.00	0.00	156.27	477,103.86
Deferred Compensation	2.55	0.00	0.00	0.00	2.55
Debt Service Series 2007	18,927.53	0.00	0.00	6.20	18,933.73
Capital Projects Series 2005	228,084.64	0.00	0.00	74.75	228,159.39
Student Activity Funds	41,016.22	0.00	0.00	13.42	41,029.64
Taylor Ray Donation Account	2,566.55	0.00	0.00	0.90	2,567.45
Capital Projects Series 2007	209,808.00	0.00	0.00	68.72	209,876.72
Common Threads Donation	53,409.78	0.00	0.00	17.50	53,427.28
Debt Service Series 2008	18,073.16	0.00	0.00	5.91	18,079.07
Capital Projects 2012A	2,370,141.10	0.00	0.00	776.62	2,370,917.72
Debt Service 2012A	18,514.54	0.00	0.00	6.10	18,520.64
Debt Service 2012B	9,443.25	0.00	0.00	3.05	9,446.30
Debt Service 2014A	514,032.98	0.00	0.00	168.45	514,201.43
Debt Service 2014B	180,162.30	0.00	0.00	59.03	180,221.33
Debt Service 2013	7,998.26	0.00	0.00	2.65	8,000.91
Debt Service 2013A	553,754.37	0.00	0.00	181.45	553,935.82
Debt Service 2015	25,330.64	0.00	0.00	8.29	25,338.93
Capital Projects 2015	447,084.29	0.00	447,083.29	58.89	59.89
Debt Service 2016A	114.38	0.00	0.00	0.00	114.38
Lone Star Investment Pool Government Overnight Fund					
Capital Projects Fund	5,037.92	0.00	0.00	1.65	5,039.57
Workers' Comp	723,300.47	0.00	0.00	236.37	723,536.84
Property Tax Fund	32,268.63	0.00	0.00	10.55	32,279.18
General Fund	2,596,650.04	0.00	0.00	848.57	2,597,498.61
Food Service Fund	90,797.34	0.00	0.00	29.67	90,827.01
Debt Service Series 1996	0.01	0.00	0.00	0.00	0.01
Capital Project Series 1998	703.01	0.00	0.00	0.23	703.24
Debt Service Series 1990	0.04	0.00	0.00	0.00	0.04
Debt Service Series 1999	2.43	0.00	0.00	0.00	2.43
Capital Project Series 1999	0.01	0.00	0.00	0.00	0.01
Capital Projects 2007	385.37	0.00	0.00	0.13	385.50
Capital Projects 2008	0.31	0.00	0.00	0.00	0.31
Capital Projects 2012A	43.01	0.00	0.00	0.01	43.02
Capital Projects 2014A	822,134.45	0.00	0.00	268.67	822,403.12
Capital Projects 2014B	17.08	0.00	0.00	0.01	17.09
Capital Projects 2015	26,715,348.74	0.00	0.00	8,730.39	26,724,079.13
Debt Service Series 2015	1,891,438.34	0.00	0.00	618.11	1,892,056.45
MBIA Texas CLASS Fund					
General Account	15,448,924.51	0.00	0.00	10,588.41	15,459,512.92
Capital Project Series 1998	910.78	0.00	0.00	0.60	911.38
Capital Projects Series 2007	1.00	0.00	0.00	0.00	1.00
Debt Service Series 2007	1.00	0.00	0.00	0.00	1.00
Capital Projects Series 2012A	11,121,275.84	0.00	0.00	7,622.30	11,128,898.14
Capital Projects 2015	14,649,927.49	0.00	0.00	10,040.77	14,659,968.26
Debt Service 2015	948,328.73	0.00	0.00	649.98	948,978.71
TEXSTAR					
Capital Projects Series 2007	745.48	0.00	0.00	0.29	745.77
Debt Service Series 2008	13.86	0.00	0.00	0.00	13.86
Capital Projects Series 2008	1,042,056.61	0.00	39,858.20	349.03	1,002,547.44
Debt Service Series 2012A	40.45	0.00	0.00	0.00	40.45
Debt Service Series 2012B	1,708.55	0.00	0.00	0.60	1,709.15
Capital Projects Series 2012A	12.21	0.00	0.00	0.00	12.21
Debt Service 2013	4,526.02	0.00	0.00	1.52	4,527.54
Capital Projects 2014A	139.59	0.00	0.00	0.01	139.60
Capital Projects 2014B	78,037.16	0.00	0.00	26.59	78,063.75
Debt Service 2015	3,310,686.02	0.00	0.00	1,127.75	3,311,813.77
Capital Projects 2015	47,844,341.50	0.00	0.00	16,297.37	47,860,638.87
TEXAS TERM/DAILY Fund					
Capital Projects Series 2007	1,009,086.87	0.00	0.00	370.73	1,009,457.60
Capital Projects Series 2008	141.32	0.00	0.00	0.05	141.37
Capital Projects Series 2012A	399,021.14	0.00	399,020.14	55.76	56.76
Capital Projects Series 2014A	4,363,755.24	0.00	4,146,223.57	317.20	217,848.87
Capital Projects Series 2014B	5,202,334.78	0.00	2,314,955.50	1,220.97	2,888,600.25
Debt Service 2015	135,196.48	0.00	0.00	49.67	135,246.15
Capital Projects 2015	21,724,781.14	0.00	6,515,815.95	5,824.06	15,214,789.25
			AVG. RATE OF RETURN	CURRENT MONTH EARNINGS	
TEXPOOL ACCOUNT INTEREST			0.40	\$29,416.64	
LONE STAR ACCOUNT INTEREST			0.40	\$10,744.36	
MBIA TEXAS CLASS ACCOUNT INTEREST			0.90	\$28,902.06	
TEXSTAR ACCOUNT INTEREST			0.43	\$17,803.16	
TEXAS TERM/DAILY ACCOUNT INTEREST			0.45	\$7,838.44	
TOTAL CURRENT MONTH EARNINGS					\$94,704.66
EARNINGS 9-01-16 THRU 10-30-16					\$202,410.92
TOTAL CURRENT SCHOOL YEAR EARNINGS					\$297,115.58

CONSIDER APPROVAL OF AN ORDER AUTHORIZING THE ISSUANCE OF LAMAR CONSOLIDATED INDEPENDENT SCHOOL DISTRICT UNLIMITED TAX SCHOOLHOUSE BONDS, SERIES 2017; APPROVING THE PREPARATION OF AN OFFICIAL STATEMENT; AND ENACTING OTHER PROVISIONS RELATING THERETO

RECOMMENDATION:

That the Board of Trustees approve the Order Authorizing the Issuance of Lamar Consolidated Independent School District Unlimited Tax Schoolhouse Bonds, Series 2017.

IMPACT/RATIONALE:

The voters of Lamar Consolidated Independent School District authorized the issuance of \$240,647,552 in schoolhouse bonds in an election held November 4, 2014. Based on the requirements of the project schedule, administration and the District's financial advisor recommend selling the remaining \$95.048 million of the authorization. The Bonds will be sold as traditional fixed rate bonds. Attached is a schedule of events surrounding the sale and delivery of the Bonds.

A draft of the Order Authorizing the Issuance of Lamar Consolidated Independent School District Unlimited Tax Schoolhouse Bonds, Series 2017 is attached. Within the order there are certain parameters that must be met to allow the Authorized Officer to execute the transaction. Those parameters are:

- the price to be paid for the Series 2017 Bonds shall not be less than 100% of the aggregate original principal amount of the Bonds plus accrued interest thereon from their date to the date of delivery;
- the true interest cost (TIC) of the Bonds shall not exceed 5.00%, which amount is less than the maximum rate allowed under Section 1204.006 of the Texas Government Code, as amended;
- the aggregate principal amount of the Series 2017 Bonds issued shall not exceed the total maximum principal amount of \$95,047,552; and
- no bond shall mature later than December 31, 2049.

A copy of the entire Preliminary Official Statement (prospectus) will be available when complete. Mr. Terrell Palmer (FirstSouthwest, a Division of Hilltop Securities), Mr. Jonathan Frels (Bracewell LLP), and District personnel will be present at the meeting to answer questions.

PROGRAM DESCRIPTION:

It is required that the Board of Trustees approve the Order authorizing the sale of the new money bonds. Since this is the final sale of bonds authorized in 2014, the underwriting team approved by the Board of Trustees will remain in place for this transaction. The underwriting team has the ability to assess the District's goals, the skills to effectively market the bonds, and the ability to risk its own capital, if necessary. The underwriting team consists of underwriters, a sales force, and bankers. Underwriters set the price on the bonds, the sales force sells the bonds to the public, and the bankers ensure that the goals of the District are achieved. The underwriting team for this sale was selected using a Request for Proposal process. The District's financial advisory firm will assist the District with the sale of schoolhouse bonds.

Submitted by: Jill Ludwig, CPA, RTSBA, Chief Financial Officer

Recommended for approval:



Dr. Thomas Randle
Superintendent

FINANCING TIMETABLE

as of 11/16/2016

Lamar Consolidated Independent School District Unlimited Tax Schoolhouse Bonds, Series 2017

Nov 2016							Dec 2016							Jan 2017							Feb 2017						
S	M	T	W	T	F	S	S	M	T	W	T	F	S	S	M	T	W	T	F	S	S	M	T	W	T	F	S
		1	2	3	4	5				1	2	3	1	2	3	4	5	6	7				1	2	3	4	
6	7	8	9	10	11	12	4	5	6	7	8	9	10	8	9	10	11	12	13	14	5	6	7	8	9	10	11
13	14	15	16	17	18	19	11	12	13	14	15	16	17	15	16	17	18	19	20	21	12	13	14	15	16	17	18
20	21	22	23	24	25	26	18	19	20	21	22	23	24	22	23	24	25	26	27	28	19	20	21	22	23	24	25
27	28	29	30				25	26	27	28	29	30	31	29	30	31					26	27	28				

Holiday
 Board Meeting

Date	Event	Responsibility
Mon 10/31	Apply for PSF guarantee	FA
Wed 11/16	Send information request to LCISD	FA
Mon 11/21	Receive preliminary approval for PSF guarantee	LCISD
Wed 11/30	Return requested information to FA	LCISD
Mon 12/5	Distribute first draft of Preliminary Official Statement ("POS")	FA
Mon 12/12	Return comments on POS	All
Thu 12/15	Board Meeting: Adopt bond order; approve parameters for sale of bonds; select underwriters; authorize distribution of POS	LCISD
Fri 12/16	Submit credit package to rating agencies	FA
Fri 12/16	Distribute revised draft of POS	FA
Week of 1/2	Conduct conference calls with rating agencies	LCISD, FA
Wed 1/4	Return comments on POS	All
Fri 1/6	Distribute final draft of POS	FA
Wed 1/11	Conduct due diligence conference call	All
Fri 1/13	Return final comments on POS	All
Fri 1/13	Receive ratings on bonds	LCISD, FA
Tue 1/17	Distribute POS	FA
Tue 1/24	Price Bonds	UW
Wed 1/25	Distribute draft of final Official Statement ("OS")	FA
Mon 1/30	Return comments on OS	All
Tue 1/31	Print and distribute OS	FA
Mon 2/13	Distribute draft of closing memorandum	FA
Mon 2/20	Distribute closing memorandum	FA
Wed 2/22	Closing	All

LCISD = Issuer = Lamar Consolidated Independent School District
 BC = Bond Counsel = Bracewell LLP
 FA = Financial Advisor = FirstSouthwest, a Division of Hilltop Securities Inc.
 UC = Underwriter's Counsel = TBD
 UW = Underwriters = TBD

ORDER
AUTHORIZING THE ISSUANCE OF

LAMAR CONSOLIDATED INDEPENDENT SCHOOL DISTRICT
UNLIMITED TAX SCHOOLHOUSE BONDS
SERIES 2017

Adopted: December 15, 2016

TABLE OF CONTENTS

Page

ARTICLE I
DEFINITIONS AND OTHER PRELIMINARY MATTERS

Section 1.01. Definitions2
 Section 1.02. Other Definitions4
 Section 1.03. Findings4
 Section 1.04. Table of Contents, Titles and Headings4
 Section 1.05. Interpretation5

ARTICLE II
SECURITY FOR THE BONDS

Section 2.01. Tax Levy5

ARTICLE III
AUTHORIZATION; GENERAL TERMS AND PROVISIONS
REGARDING THE BONDS

Section 3.01. Authorization5
 Section 3.02. Date, Denomination, Maturities, and Interest6
 Section 3.03. Medium, Method and Place of Payment6
 Section 3.04. Execution and Registration of Bonds7
 Section 3.05. Ownership8
 Section 3.06. Registration, Transfer and Exchange8
 Section 3.07. Cancellation9
 Section 3.08. Replacement Bonds9
 Section 3.09. Book–Entry Only System10
 Section 3.10. Successor Securities Depository; Transfer Outside Book–Entry Only
 System11
 Section 3.11. Payments to Cede & Co11

ARTICLE IV
REDEMPTION OF BONDS BEFORE MATURITY

Section 4.01. Limitation on Redemption11
 Section 4.02. Optional Redemption11
 Section 4.03. Mandatory Sinking Fund Redemption11
 Section 4.04. Partial Redemption12
 Section 4.05. Notice of Redemption to Owners12
 Section 4.06. Payment Upon Redemption13
 Section 4.07. Effect of Redemption13
 Section 4.08. Lapse of Payment13

ARTICLE V
PAYING AGENT/REGISTRAR

Section 5.01.	Appointment of Initial Paying Agent/Registrar	13
Section 5.02.	Qualifications	14
Section 5.03.	Maintaining Paying Agent/Registrar.....	14
Section 5.04.	Termination	14
Section 5.05.	Notice of Change to Owners	14
Section 5.06.	Agreement to Perform Duties and Functions	14
Section 5.07.	Delivery of Records to Successor	14

ARTICLE VI
FORM OF THE BONDS

Section 6.01.	Form Generally	14
Section 6.02.	CUSIP Registration	15
Section 6.03.	Legal Opinion.....	15

ARTICLE VII
SALE AND DELIVERY OF BONDS; DEPOSIT OF PROCEEDS

Section 7.01.	Sale of Bonds, Official Statement	15
Section 7.02.	Control and Delivery of Bonds	17
Section 7.03.	Deposit of Proceeds.....	17

ARTICLE VIII
PARTICULAR REPRESENTATIONS AND COVENANTS

Section 8.01.	Payment of the Bonds	17
Section 8.02.	Other Representations and Covenants.....	17
Section 8.03.	Federal Income Tax Exclusion.....	17

ARTICLE IX
DISCHARGE

Section 9.01.	Discharge.....	20
---------------	----------------	----

ARTICLE X
PERMANENT SCHOOL FUND GUARANTEE

Section 10.01.	Permanent School Fund Guarantee	20
----------------	---------------------------------------	----

ARTICLE XI
CONTINUING DISCLOSURE UNDERTAKING

Section 11.01.	Annual Reports.....	20
Section 11.02.	Event Notices.	21
Section 11.03.	Limitations, Disclaimers and Amendments	22

ARTICLE XII
MISCELLANEOUS

Section 12.01.	Changes to Order.....	24
Section 12.02.	Partial Invalidity	24
Section 12.03.	No Personal Liability	24
Section 12.04.	Related Matters.....	24
Section 12.05.	Force and Effect	24

Exhibit A – Form of Bond

AN ORDER AUTHORIZING THE ISSUANCE OF LAMAR CONSOLIDATED INDEPENDENT SCHOOL DISTRICT UNLIMITED TAX SCHOOLHOUSE BONDS, SERIES 2017; APPROVING THE PREPARATION OF AN OFFICIAL STATEMENT; AND ENACTING OTHER PROVISIONS RELATING THERETO

WHEREAS, the Lamar Consolidated Independent School District (the “District”) desires to issue schoolhouse bonds voted by the voters of the District pursuant to the Constitution and laws of the State of Texas, including particularly Chapter 45 of the Texas Education Code, as amended (“Chapter 45”) at an election held within the District on November 4, 2014 (the “Election”); and

WHEREAS, at said Election, the voters authorized the amount of schoolhouse bonds set forth below in the following schedule, such schedule also showing amounts previously issued pursuant to such voted authorization; and

Election	Amount Voted	Amount Previously Issued	Authorized but Unissued Balance
November 4, 2014	\$240,647,552	\$145,600,000	\$95,047,552

WHEREAS the Board of Trustees of the District (the “Board”) does hereby determine that the schoolhouse bonds in an amount not to exceed the remaining authorized but unissued balance from the November 4, 2014 election, including any premium charged against voted authority, should be issued as the final installment of the \$240,647,552 schoolhouse bonds voted the Election; and

WHEREAS, the actual amount issued from the Election pursuant to this Order and the balance that remains after the issuance of the schoolhouse bonds authorized in this Order will be indicated in the Pricing Certificate (as defined herein); and

WHEREAS, the Board has found and determined that it is necessary and in the best interest of the District and its citizens that it authorize by this Order the issuance and delivery of such schoolhouse bonds for the construction, acquisition and equipment of school buildings in the District, for the purchase of the necessary sites for school buildings and the purchase of new school buses; and

WHEREAS, the schoolhouse bonds are authorized to be issued pursuant to Chapter 45; and

WHEREAS, the District has a principal amount of at least \$100,000,000 in a combination of outstanding long-term indebtedness and long-term indebtedness proposed to be issued, and some amount of such long-term indebtedness is rated in one of the four highest rating categories for long-term debt instruments by a nationally recognized rating agency for municipal securities without regard to the effect of any credit agreement or other form of credit enhancement entered into in connection with the obligation, and therefore qualifies as an “Issuer” under Chapter 1371 of the Texas Government Code, as amended (“Chapter 1371”); and

WHEREAS, pursuant to Chapter 1371, the District desires to delegate the authority to effect the sale of the Bonds (as hereinafter defined) to the Authorized Officer; and

WHEREAS, the meeting at which this Order is being considered is open to the public as required by law, and the public notice of the time, place and purpose of said meeting was given as required by Chapter 551, Texas Government Code; NOW, THEREFORE

BE IT ORDERED BY THE BOARD OF TRUSTEES OF LAMAR CONSOLIDATED INDEPENDENT SCHOOL DISTRICT:

ARTICLE I

DEFINITIONS AND OTHER PRELIMINARY MATTERS

Section 1.01. Definitions. Unless otherwise expressly provided in this Order, or unless the context clearly requires otherwise, the following terms shall have the meanings specified below:

“Authorized Officer” means the Superintendent or the Chief Financial Officer of the District.

“Board” means the Board of Trustees of the District.

“Bond” means any series or subseries of the Bonds issued pursuant to this Order as context requires.

“Bonds” means the District’s bonds authorized to be issued by Section 3.01.

“Bond Counsel” means Bracewell LLP.

“Business Day” means a day that is not a Saturday, Sunday, legal holiday or other day on which banking institutions in the city where the Designated Payment/Transfer Office is located are required or authorized by law or executive order to close.

“Closing Date” means the date of the initial delivery of and payment for the Bonds.

“Code” means the Internal Revenue Code of 1986, as amended, and, with respect to a specific section thereof, such reference shall be deemed to include (a) the Regulations promulgated under such section, (b) any successor provision of similar import hereafter enacted, (c) any corresponding provision of any subsequent Internal Revenue Code, and (d) the regulations promulgated under the provisions described in (b) and (c).

“Dated Date” means the date designated as the date of the Bonds in the Pricing Certificate.

“Debt Service” means, collectively, all amounts due and payable with respect to the Bonds representing the principal, premium, if any, and the interest due on the Bonds, payable at the times and in the manner provided herein and in the Pricing Certificate.

“Designated Payment/Transfer Office” means (i) with respect to the initial Paying Agent/Registrar named in the Pricing Certificate, the Designated Payment/Transfer Office as designated in the Paying Agent/Registrar Agreement, or at such other location designated by the Paying Agent/Registrar, and (ii) with respect to any successor Paying Agent/Registrar, the office of such successor designated and located as may be agreed upon by the District and such successor.

“DTC” shall mean The Depository Trust Company of New York, New York, or any successor securities depository.

“DTC Participant” shall mean brokers and dealers, banks, trust companies, clearing corporations and certain other organizations on whose behalf DTC was created to hold securities to facilitate the clearance and settlement of securities transactions among DTC Participants.

“Fiscal Year” means such fiscal year of the District as shall be set from time to time by the Board.

“Initial Bond” means the Initial Bond authorized by Section 3.04(d).

“Interest Payment Date” means, with respect to the Bonds, the date or dates on which interest on the Bonds is scheduled to be paid, as designated in the Pricing Certificate.

“Maturity” means the date on which the principal of the Bonds becomes due and payable according to the terms thereof, whether at Stated Maturity or by proceedings for prior redemption.

“MSRB” means the Municipal Securities Rulemaking Board.

“Order” means this Order.

“Owner” means the person who is the registered owner of a Bond or Bonds, as shown in the Register.

“Paying Agent/Registrar” means the paying agent/registrar designated in the Pricing Certificate.

“Paying Agent Registrar Agreement” means the Paying Agent/Registrar Agreement between the Paying Agent/Registrar and the District relating to the Bonds.

“Pricing Certificate” means a certificate or certificates to be signed by the Authorized Officer in connection with the issuance of Bonds under this Order.

“Purchase Contract” means the purchase contract or purchase contracts between the District and the Underwriters pertaining to the sale of the Bonds.

“Record Date” means the Record Date set forth in the Pricing Certificate.

“Register” means the Bond register required by Section 3.06(a).

“Regulations” means the applicable proposed, temporary or final Treasury Regulations promulgated under the Code or, to the extent applicable to the Code, under the Internal Revenue Code of 1954, as such regulations may be amended or supplemented from time to time.

“Representation Letter” means the Blanket Letter of Representations between the District and DTC.

“Representative” means the representative of the Underwriters designated in the Purchase Contract.

“Rule” means SEC Rule 15c2-12, as amended from time to time.

“SEC” means the United States Securities and Exchange Commission.

“Special Payment Date” means the date that is 15 days after the Special Record Date, as described in Section 3.03(e).

“Special Record Date” means the new record date for interest payment established in the event of a nonpayment of interest on a scheduled payment date, and for 30 days thereafter, as described in Section 3.03(e).

“State” means the State of Texas.

“Stated Maturity” means the respective stated maturity dates of the Bonds specified in the Pricing Certificate.

“Unclaimed Payments” means money deposited with the Paying Agent/Registrar for the payment of Debt Service or money set aside for the payment of Bonds duly called for redemption prior to Stated Maturity and remaining unclaimed by the Owners of such Bonds for 90 days after the applicable payment or redemption date.

“Underwriters” mean the underwriters named in the Purchase Contract.

Section 1.02. Other Definitions. The capitalized terms defined in the preamble to this Order shall have the meanings assigned to them in the preamble to this Order.

Section 1.03. Findings. The declarations, determinations and findings declared, made and found in the preamble to this Order are hereby adopted, restated and made a part of the operative provisions hereof.

Section 1.04. Table of Contents, Titles and Headings. The table of contents, titles and headings of the Articles and Sections of this Order have been inserted for convenience of reference only and are not to be considered a part hereof and shall not in any way modify or restrict any of the terms or provisions hereof and shall never be considered or given any effect in

construing this Order or any provision hereof or in ascertaining intent, if any question of intent should arise.

Section 1.05. Interpretation. (a) Unless the context requires otherwise, words of the masculine gender shall be construed to include correlative words of the feminine and neuter genders and vice versa, and words of the singular number shall be construed to include correlative words of the plural number and vice versa.

(b) This Order and all the terms and provisions hereof shall be liberally construed to effectuate the purposes set forth herein to sustain the validity of this Order.

(c) All article and section references shall mean references to the respective articles and sections of this Order unless designated otherwise.

ARTICLE II

SECURITY FOR THE BONDS

Section 2.01. Tax Levy. (a) Pursuant to the authority granted by the Constitution and laws of the State, there is hereby levied for the current year and for each succeeding year hereafter while any of the Bonds or any interest thereon is outstanding and unpaid, an ad valorem tax, with respect to the Bonds, on each one hundred dollars valuation of taxable property within the District, at a rate sufficient, without limit as to rate or amount, to pay Debt Service when due and payable, full allowance being made for delinquencies and costs of collection, and said taxes are hereby irrevocably pledged to pay Debt Service and associated costs and to no other purpose; such tax shall be assessed and collected each such year; the proceeds of such tax shall be credited to the interest and sinking fund designated for the Bonds; and the proceeds of such tax shall be appropriated and applied to Debt Service and associated costs on the Bonds.

(b) To pay the Debt Service coming due on the Bonds prior to receipt of the taxes levied to pay such Debt Service, if any, there is hereby appropriated from current funds on hand, which are hereby certified to be on hand and available for such purpose, an amount sufficient to pay such Debt Service, and such amount shall be used for no other purpose.

(c) Any money received by the District with respect to the Bonds as state assistance pursuant to the instructional allotment or as state assistance with existing debt, each as authorized by Chapter 46, Texas Education Code, shall be deposited in the interest and sinking fund as required by Sections 46.009 and 46.035, Texas Education Code, respectively. The District will take into account the balance in the interest and sinking fund when it sets its debt service tax rate each year.

ARTICLE III

AUTHORIZATION; GENERAL TERMS AND PROVISIONS REGARDING THE BONDS

Section 3.01. Authorization. The District's bonds to be designated "Lamar Consolidated Independent School District Unlimited Tax Schoolhouse Bonds, Series 2017" or

such other title or titles as may be designated in the Pricing Certificate are hereby authorized to be issued and delivered from time to time in accordance with the Constitution and laws of the State of Texas, including particularly Chapter 45, Texas Education Code, and Chapter 1371, Texas Government Code. The Bonds shall be issued in an aggregate principal amount not to exceed \$95,047,552 for the construction, acquisition and equipment of school buildings in the District, for the purchase of the necessary sites for school buildings, and the purchase of new school buses and to pay the costs of issuing the Bonds.

Section 3.02. Date, Denomination, Maturities, and Interest. (a) The Bonds shall be dated the Dated Date as set forth in the Pricing Certificate and shall be in fully registered form without coupons.

(b) The Bonds shall be in the aggregate principal amount designated in the Pricing Certificate, shall be in the denomination of \$5,000 principal amount or any integral multiple thereof and shall be numbered separately from one upward, except the Initial Bond which shall be numbered I-1.

(c) The Bonds shall mature on the dates and in the principal amounts and shall bear interest at the per annum rates set forth in the Pricing Certificate.

(d) Interest shall accrue and be paid on each Bond, respectively, until the principal amount thereof has been paid or provision for such payment has been made, from the later of (i) the Dated Date, unless otherwise provided in the Pricing Certificate, or (ii) the most recent Interest Payment Date to which interest has been paid or provided for at the rate per annum for each respective maturity specified in the Pricing Certificate. Such interest shall be payable on each Interest Payment Date and shall be computed on the basis of a 360-day year of twelve 30-day months.

Section 3.03. Medium, Method and Place of Payment. (a) Debt Service shall be paid in lawful money of the United States of America.

(b) Interest on each Bond shall be paid by check dated as of the Interest Payment Date, and sent first class United States mail, postage prepaid, by the Paying Agent/Registrar to each Owner, as shown in the Register at the close of business on the Record Date, at the address of each such Owner as such appears in the Register or by such other customary banking arrangements acceptable to the Paying Agent/Registrar and the person to whom interest is to be paid; provided, however, that such person shall bear all risk and expense of such other customary banking arrangements.

(c) The principal of each Bond shall be paid to the Owner thereof at Maturity upon presentation and surrender of such Bond at the Designated Payment/Transfer Office of the Paying Agent/Registrar.

(d) If the date for the payment of Debt Service is not a Business Day, the date for such payment shall be the next succeeding Business Day, and payment on such date shall for all purposes be deemed to have been made on the due date thereof as specified in this Section.

(e) In the event of a nonpayment of interest on a scheduled payment date, and for 30 days thereafter, a new record date for such interest payment (a "Special Record Date") will be established by the Paying Agent/Registrar, if and when funds for the payment of such interest have been received from the District. Notice of the Special Record Date and of the special payment date of the past due interest (the "Special Payment Date," which shall be 15 days after the Special Record Date) shall be sent at least five (5) Business Days prior to the Special Record Date by United States mail, first class, postage prepaid, to the address of each Owner of a Bond appearing on the books of the Paying Agent/Registrar at the close of business on the last Business Day next preceding the date of mailing of such notice.

(f) Unclaimed Payments shall be segregated in a special account and held in trust, uninvested by the Paying Agent/Registrar, for the account of the Owner of the Bonds to which the Unclaimed Payments pertain. Subject to Title 6, Texas Property Code, Unclaimed Payments remaining unclaimed by the Owners entitled thereto for three (3) years after the applicable payment or redemption date shall be applied to the next payment or payments on the Bonds thereafter coming due and, to the extent any such money remains after the retirement of all outstanding Bonds, shall be paid to the District to be used for any lawful purpose. Thereafter, neither the District, the Paying Agent/Registrar nor any other person shall be liable or responsible to any holders of such Bonds for any further payment of such unclaimed moneys or on account of any such Bonds, subject to Title 6, Texas Property Code.

Section 3.04. Execution and Registration of Bonds. (a) The Bonds shall be executed on behalf of the District by the President or Vice President and the Secretary of the Board, by their manual or facsimile signatures, and the official seal of the District shall be impressed or placed in facsimile thereon. Such facsimile signatures on the Bonds shall have the same effect as if each of the Bonds had been signed manually and in person by each of said officers, and such facsimile seal on the Bonds shall have the same effect as if the official seal of the District had been manually impressed upon each of the Bonds.

(b) In the event that any officer of the District whose manual or facsimile signature appears on the Bonds ceases to be such officer before the authentication of such Bonds or before the delivery thereof, such facsimile signature nevertheless shall be valid and sufficient for all purposes as if such officer had remained in such office.

(c) Except as provided below, no Bond shall be valid or obligatory for any purpose or be entitled to any security or benefit of this Order unless and until there appears thereon the Certificate of Paying Agent/Registrar substantially in the form provided herein, duly authenticated by manual execution by an officer or duly authorized signatory of the Paying Agent/Registrar. It shall not be required that the same officer or authorized signatory of the Paying Agent/Registrar sign the Certificate of Paying Agent/Registrar on all of the Bonds. In lieu of the executed Certificate of Paying Agent/Registrar described above, the Initial Bonds delivered at the Closing Date shall have attached thereto the Comptroller's Registration Certificate substantially in the form provided herein, manually executed by the Comptroller of Public Accounts of the State of Texas, or by her duly authorized agent, which certificate shall be evidence that the Initial Bonds have been duly approved by the Attorney General of the State of Texas and that they are valid and binding obligations of the District, and have been registered by the Comptroller of Public Accounts of the State of Texas.

(d) On the Closing Date, the Initial Bond, representing the entire principal amount of the Bonds for such series of Bonds designated in the Pricing Certificate, to be payable in stated installments to the Representative or its designee, to be executed by manual or facsimile signatures of the President or Vice President and Secretary of the Board, approved by the Attorney General, and registered and manually signed by the Comptroller of Public Accounts, will be delivered to the Representative or its designee. Upon payment for the Initial Bond, the Paying Agent/Registrar shall cancel the Initial Bond and deliver registered definitive Bonds to DTC in accordance with Section 3.09. To the extent the Paying Agent/Registrar is eligible to participate in DTC's FAST System, as evidenced by an agreement between the Paying Agent/Registrar and DTC, the Paying Agent/Registrar shall hold the definitive Bonds in safekeeping for DTC.

Section 3.05. Ownership. (a) The District, the Paying Agent/Registrar and any other person may treat the Owner as the absolute owner of such Bond for the purpose of making and receiving payment of the principal thereof, as applicable, for the further purpose of making and receiving payment of the interest thereon (subject to the provision herein that for the Bonds interest is to be paid to the person in whose name the Bond is registered on the Record Date or Special Record Date, as applicable), and for all other purposes, whether or not such Bond is overdue, and neither the District nor the Paying Agent/Registrar shall be bound by any notice or knowledge to the contrary.

(b) All payments made to the Owner of a Bond shall be valid and effectual and shall discharge the liability of the District and the Paying Agent/Registrar upon such Bond to the extent of the sums paid.

Section 3.06. Registration, Transfer and Exchange. (a) So long as any Bonds remain outstanding, the District shall cause the Paying Agent/Registrar to keep at its Designated Payment/Transfer Office the Register in which, subject to such reasonable regulations as it may prescribe, the Paying Agent/Registrar shall provide for the registration and transfer of Bonds in accordance with this Order.

(b) The ownership of a Bond may be transferred only upon the presentation and surrender of the Bond to the Paying Agent/Registrar at the Designated Payment/Transfer Office with such endorsement or other instrument of transfer and assignment acceptable to the Paying Agent/Registrar. No transfer of any Bond shall be effective until entered in the Register.

(c) The Bonds shall be exchangeable upon the presentation and surrender thereof at the Designated Payment/Transfer Office for a Bond or Bonds of the same maturity and interest rate and in any denomination or denominations of any integral multiple of \$5,000 and in an aggregate principal equal to the unpaid principal amount of the Bonds presented for exchange.

(d) The Paying Agent/Registrar is hereby authorized to authenticate and deliver Bonds transferred or exchanged in accordance with this Section. A new Bond or Bonds will be delivered by the Paying Agent/Registrar, in lieu of the Bond being transferred or exchanged, at the Designated Payment/Transfer, or sent by United States mail, first class, postage prepaid, to the Owner or his designee. Each Bond delivered by the Paying Agent/Registrar in accordance with this Section shall constitute an original contractual obligation of the District and shall be

entitled to the benefits and security of this Order to the same extent as the Bond or Bonds in lieu of which such Bond is delivered.

(e) No service charge shall be made to the Owner for the initial registration, any subsequent transfer, or exchange for a different denomination of any of the Bonds. The Paying Agent/Registrar, however, may require the Owner to pay a sum sufficient to cover any tax or other governmental charge that is authorized to be imposed in connection with the registration, transfer or exchange of a Bond.

(f) Neither the District nor the Paying Agent/Registrar shall be required to transfer or exchange any Bond called for redemption within 45 days of the date fixed for redemption; provided, however, such limitation of transfer shall not be applicable to an exchange by the registered owner of the uncalled balance of a Bond.

Section 3.07. Cancellation. All Bonds paid or redeemed before Stated Maturity in accordance with this Order, and all Bonds in lieu of which exchange Bonds or replacement Bonds are authenticated and delivered in accordance with this Order, shall be cancelled upon the making of proper records regarding such payment, exchange or replacement. The Paying Agent/Registrar shall dispose of such cancelled Bonds in the manner required by the Securities Exchange Act of 1934, as amended.

Section 3.08. Replacement Bonds. (a) Upon the presentation and surrender to the Paying Agent/Registrar of a mutilated Bond, the Paying Agent/Registrar shall authenticate and deliver in exchange therefor a replacement Bond of like tenor and principal amount bearing a number not contemporaneously outstanding. The District or the Paying Agent/Registrar may require the Owner of such Bond to pay a sum sufficient to cover any tax or other governmental charge that is authorized to be imposed in connection therewith and any other expenses connected therewith.

(b) In the event that any Bond is lost, apparently destroyed or wrongfully taken, the Paying Agent/Registrar, pursuant to the applicable laws of the State of Texas and in the absence of notice or knowledge that such Bond has been acquired by a bona fide purchaser, shall authenticate and deliver a replacement Bond of like tenor and principal amount and bearing a number not contemporaneously outstanding, provided that the Owner first complies with the following requirements:

(i) furnishes to the Paying Agent/Registrar satisfactory evidence of his or her ownership of and the circumstances of the loss, destruction or theft of such Bond;

(ii) furnishes such security or indemnity as may be required by the Paying Agent/Registrar and the District to save them harmless;

(iii) pays all expenses and charges in connection therewith, including, but not limited to, printing costs, legal fees, fees of the Paying Agent/Registrar and any tax or other governmental charge that is authorized to be imposed; and

(iv) satisfies any other reasonable requirements imposed by the District and the Paying Agent/Registrar.

(c) If, after the delivery of such replacement Bond, a bona fide purchaser of the original Bond in lieu of which such replacement Bond was issued presents for payment such original Bond, the District and the Paying Agent/Registrar shall be entitled to recover such replacement Bond from the person to whom it was delivered or any person taking therefrom, except a bona fide purchaser, and shall be entitled to recover upon the security or indemnity provided therefor to the extent of any loss, damage, cost or expense incurred by the District or the Paying Agent/Registrar in connection therewith.

(d) In the event that any such mutilated, lost, apparently destroyed or wrongfully taken Bond has become or is about to become due and payable, the Paying Agent/Registrar, in its discretion, instead of issuing a replacement Bond, may pay such Bond if it has become due and payable or may pay such Bond when it becomes due and payable.

(e) Each replacement Bond delivered in accordance with this Section shall constitute an original additional contractual obligation of the District and shall be entitled to the benefits and security of this Order to the same extent as the Bond or Bonds in lieu of which such replacement Bond is delivered.

Section 3.09. Book-Entry Only System. (a) The definitive Bonds shall be initially issued in the form of a fully registered Bond for each of the maturities thereof. Upon initial issuance, the ownership of each such Bond shall be registered in the name of Cede & Co., as nominee of DTC, and except as provided in Section 3.10 hereof, all of the outstanding Bonds shall be registered in the name of Cede & Co., as nominee of DTC.

(b) With respect to Bonds registered in the name of Cede & Co., as nominee of DTC, the District and the Paying Agent/Registrar shall have no responsibility or obligation to any DTC Participant or to any person on behalf of whom such a DTC Participant holds an interest in the Bonds, except as provided in this Order. Without limiting the immediately preceding sentence, the District and the Paying Agent/Registrar shall have no responsibility or obligation with respect to (i) the accuracy of the records of DTC, Cede & Co. or any DTC Participant with respect to any ownership interest in the Bonds, (ii) the delivery to any DTC Participant or any other person, other than an Owner, of any notice with respect to the Bonds, including any notice of redemption, or (iii) the payment to any DTC Participant or any other person, other than an Owner, of any amount with respect to Debt Service. Notwithstanding any other provision of this Order to the contrary, the District and the Paying Agent/Registrar shall be entitled to treat and consider the person in whose name each Bond is registered in the Register as the absolute Owner of such Bond for the purpose of payment of Debt Service on the Bonds for the purpose of giving notices of redemption, and other matters with respect to such Bond, for the purpose of registering transfer with respect to such Bond, and for all other purposes whatsoever. The Paying Agent/Registrar shall pay all Debt Service only to or upon the order of the respective Owners, as provided in this Order, or their respective attorneys duly authorized in writing, and all such payments shall be valid and effective to fully satisfy and discharge the District's obligations with respect to payment of, Debt Service to the extent of the sum or sums so paid. No person other than an Owner, shall receive a Bond certificate evidencing the obligation of the District to make payments of amounts due pursuant to this Order. Upon delivery by DTC to the Paying Agent/Registrar of written notice to the effect that DTC has determined to substitute a new nominee in place of Cede & Co., and subject to the provisions in this Order with respect to

interest checks being mailed to the registered Owner at the close of business on the Record Date, the word “Cede & Co.” in this Order shall refer to such new nominee of DTC.

(c) The Representation Letter previously executed and delivered by the District and applicable to the District’s obligations delivered in book-entry-only form to DTC as securities depository is hereby ratified and approved for the Bonds.

Section 3.10. Successor Securities Depository; Transfer Outside Book-Entry Only System. In the event that the District or the Paying Agent/Registrar determines that DTC is incapable of discharging its responsibilities described herein and in the Representation Letter, and that it is in the best interest of the beneficial owners of the Bonds that they be able to obtain certificated Bonds, or in the event DTC discontinues the services described herein, the District or the Paying Agent/ Registrar shall (i) appoint a successor securities depository, qualified to act as such under Section 17(a) of the Securities and Exchange Act of 1934, as amended, notify DTC and DTC Participants, as identified by DTC, of the appointment of such successor securities depository and transfer one or more separate Bonds to such successor securities depository or (ii) notify DTC and DTC Participants, as identified by DTC, of the availability through DTC of Bonds and transfer one or more separate Bonds to DTC Participants having Bonds credited to their DTC accounts, as identified by DTC. In such event, the Bonds shall no longer be restricted to being registered in the Register in the name of Cede & Co., as nominee of DTC, but may be registered in the name of the successor securities depository, or its nominee, or in whatever name or names Owners transferring or exchanging Bonds shall designate, as applicable, in accordance with the provisions of this Order.

Section 3.11. Payments to Cede & Co. Notwithstanding any other provision of this Order to the contrary, so long as any Bonds are registered in the name of Cede & Co., as nominee of DTC, all payments of Debt Service on such Bonds, and all notices with respect to such Bonds, shall be made and given, respectively, in the manner provided in the Representation Letter.

ARTICLE IV

REDEMPTION OF BONDS BEFORE MATURITY

Section 4.01. Limitation on Redemption. The Bonds shall be subject to redemption before Stated Maturity only as provided in this Article IV and in the Pricing Certificate.

Section 4.02. Optional Redemption. The Bonds shall be subject to redemption at the option of the District at such times, in such amounts, in such manner and at such redemption prices as may be designated and provided for in the Pricing Certificate.

Section 4.03. Mandatory Sinking Fund Redemption. (a) The Bonds designated as “Term Bonds” in the Pricing Certificate (“Term Bonds”), if any, are subject to scheduled mandatory redemption and will be redeemed by the District, in part, at a price equal to the principal amount thereof, without premium, plus accrued interest to the redemption date, out of moneys available for such purpose in the interest and sinking fund, on the dates and in the respective principal amounts as set forth in the Pricing Certificate.

(b) Prior to each scheduled mandatory redemption date, the Paying Agent/Registrar shall (i) select for redemption by lot, or by any other customary method that results in a random selection, a principal amount of Term Bonds equal to the aggregate principal amount of such Term Bonds to be redeemed, shall call such Term Bonds for redemption on such scheduled mandatory redemption date, and shall give notice of such redemption, as provided in Section 4.05.

(c) The principal amount of the Term Bonds required to be redeemed on any redemption date pursuant to subparagraph (a) of this Section 4.03 shall be reduced, at the option of the District, by the principal amount of any Term Bonds which, at least 45 days prior to the mandatory sinking fund redemption date (i) shall have been acquired by the District at a price not exceeding the principal amount of such Term Bonds plus accrued interest to the date of purchase thereof, and delivered to the Paying Agent/Registrar for cancellation, or (ii) shall have been redeemed pursuant to the optional redemption provisions hereof and not previously credited to a mandatory sinking fund redemption.

Section 4.04. Partial Redemption. (a) If less than all of the Bonds are to be redeemed pursuant to Section 4.02, the District shall determine the maturities and the principal amount (or mandatory sinking fund payment amount) thereof to be redeemed and shall direct the Paying Agent/Registrar to call by lot or any other customary random selection method such Bonds for redemption, and call such Bonds for redemption.

(b) A portion of a single Bond of a denomination greater than \$5,000 may be redeemed, but only in a principal amount equal to \$5,000 or any integral multiple thereof. The Paying Agent/Registrar shall treat each \$5,000 portion of such Bond as though it were a single Bond for purposes of selection for redemption.

(c) Upon surrender of any Bond for redemption in part, the Paying Agent/Registrar, in accordance with Section 3.06 of this Order, shall authenticate and deliver exchange Bonds in an aggregate principal amount equal to the unredeemed principal amount of the Bond so surrendered, such exchange being without charge.

Section 4.05. Notice of Redemption to Owners. (a) The Paying Agent/Registrar shall give notice of any redemption of Bonds by sending notice by United States mail, first class, postage prepaid, not less than 30 days before the date fixed for redemption, to the Owner of each Bond (or part thereof) to be redeemed, at the address shown in the Register at the close of business on the Business Day next preceding the date of mailing such notice.

(b) The notice shall state the redemption date, the redemption price, the place at which the Bonds are to be surrendered for payment, and, if less than all the Bonds outstanding are to be redeemed, an identification of the Bonds or portions thereof to be redeemed.

(c) The District reserves the right to give notice of its election or direction to redeem Bonds under Section 4.02 conditioned upon the occurrence of subsequent events. Such notice may state (i) that the redemption is conditioned upon the deposit of moneys and/or authorized securities, in an amount equal to the amount necessary to effect the redemption, with the Paying Agent/Registrar, or such other entity as may be authorized by law, no later than the redemption

date or (ii) that the District retains the right to rescind such notice at any time prior to the scheduled redemption date if the District delivers a certificate of the District to the Paying Agent/Registrar instructing the Paying Agent/Registrar to rescind the redemption notice, and such notice of redemption shall be of no effect if such moneys and/or authorized securities are not so deposited or if the notice is rescinded. The Paying Agent/Registrar shall give prompt notice of any such rescission of a conditional notice of redemption to the affected Owners. Any Bonds subject to conditional redemption where redemption has been rescinded shall remain outstanding.

(d) Any notice given as provided in this Section shall be conclusively presumed to have been duly given, whether or not the Owner receives such notice.

Section 4.06. Payment Upon Redemption. (a) Before or on each redemption date, the District shall deposit with the Paying Agent/Registrar money sufficient to pay all amounts due on the redemption date and the Paying Agent/Registrar shall make provision for the payment of the Bonds to be redeemed on such date by setting aside and holding in trust an amount from the interest and sinking fund or otherwise received by the Paying Agent/Registrar from the District and shall use such funds solely for the purpose of paying the principal of, redemption premium, if any, and accrued interest on the Bonds being redeemed.

(b) Upon presentation and surrender of any Bond called for redemption at the Designated Payment/Transfer Office on or after the date fixed for redemption, the Paying Agent/Registrar shall pay the principal of, redemption premium, if any, and accrued interest on such Bond to the date of redemption from the money set aside for such purpose.

Section 4.07. Effect of Redemption. (a) When Bonds have been called for redemption in whole or in part and due provision has been made to redeem same as herein provided, the Bonds or portions thereof so redeemed shall no longer be regarded as outstanding except for the purpose of receiving payment solely from the funds so provided for redemption, and the rights of the Owners to collect interest which would otherwise accrue after the redemption date on any Bond or portion thereof called for redemption shall terminate on the date fixed for redemption.

(b) If the District fails to make provision for payment of all sums due on a redemption date, then any Bond or portion thereof called for redemption shall continue to bear interest at the rate stated on the Bond until due provision is made for the payment of same.

Section 4.08. Lapse of Payment. Money set aside for the redemption of the Bonds and remaining unclaimed by the Owners thereof shall be subject to the provisions of Section 3.03(f) hereof.

ARTICLE V

PAYING AGENT/REGISTRAR

Section 5.01. Appointment of Initial Paying Agent/Registrar. (a) The Authorized Officer is hereby authorized to select and appoint the initial Paying Agent/Registrar for the Bonds, and the initial Paying Agent/Registrar shall be designated in the Pricing Certificate.

(b) The Board hereby approves the form of Paying Agent/Registrar Agreement. The Authorized Officer is hereby authorized and directed to execute and deliver or cause the execution and delivery by the President and Secretary of the Board, one or more Paying Agent/Registrar Agreements specifying the duties and responsibilities of the District and the Paying Agent/Registrar.

Section 5.02. Qualifications. Each Paying Agent/Registrar shall be a commercial bank or trust company organized under the laws of the State, or any other entity duly qualified and legally authorized to serve and perform the duties and services of paying agent and registrar for the Bonds.

Section 5.03. Maintaining Paying Agent/Registrar. (a) At all times while any Bonds are outstanding, the District will maintain a Paying Agent/Registrar that is qualified under Section 5.02 of this Order.

(b) If the Paying Agent/Registrar resigns or otherwise ceases to serve as such, the District will promptly appoint a replacement.

Section 5.04. Termination. The District reserves the right to terminate the appointment of any Paying Agent/Registrar by delivering to the entity whose appointment is to be terminated (i) 45 days written notice of the termination of the appointment and of the Paying Agent/Registrar Agreement, stating the effective date of such termination, and (ii) appointing a successor Paying Agent/Registrar; provided, that, no such termination shall be effective until a successor paying agent/registrar has assumed the duties of paying agent/registrar for the Bonds.

Section 5.05. Notice of Change to Owners. Promptly upon each change in the entity serving as Paying Agent/Registrar, the District will cause notice of the change to be sent to each Owner by first class United States mail, postage prepaid, at the address in the Register, stating the effective date of the change and the name and mailing address of the replacement Paying Agent/Registrar.

Section 5.06. Agreement to Perform Duties and Functions. By accepting the appointment as Paying Agent/Registrar, the Paying Agent/Registrar is deemed to have agreed to the provisions of this Order and that it will perform the duties and functions of Paying Agent/Registrar prescribed hereby.

Section 5.07. Delivery of Records to Successor. If a Paying Agent/Registrar is replaced, such Paying Agent/Registrar, promptly upon the appointment of the successor, will deliver the Register (or a copy thereof) and all other pertinent books and records relating to the Bonds to the successor Paying Agent/Registrar.

ARTICLE VI

FORM OF THE BONDS

Section 6.01. Form Generally. (a) The Bonds, including the Registration Certificates of the Comptroller of Public Accounts of the State of Texas to accompany the Initial Bond, the Certificate of the Paying Agent/Registrar, the Assignment forms and the Certificates of the

Permanent School Fund Guarantee to appear on each of the Bonds (i) shall be substantially in the forms set forth in Exhibit A with such appropriate insertions, omissions, substitutions, and other variations as are permitted or required by this Order and the Pricing Certificate, and (ii) may have such letters, numbers, or other marks of identification (including identifying numbers and letters of the Committee on Uniform Securities Identification Procedures of the American Bankers Association) and such legends and endorsements (including any reproduction of an opinion of counsel) thereon as, consistently herewith, may be determined by the District or by the officers executing such Bonds, as evidenced by their execution thereof.

(b) Any portion of the text of any Bonds may be set forth on the reverse side thereof, with an appropriate reference thereto on the face of the Bonds.

(c) The Bonds shall be typewritten, photocopied, printed, lithographed, or engraved, and may be produced by any combination of these methods or produced in any other similar manner, all as determined by the officers executing such Bonds, as evidenced by their execution thereof.

Section 6.02. CUSIP Registration. The District may secure identification numbers through the CUSIP Service Bureau Division of Standard & Poor's Corporation, New York, New York, and may authorize the printing of such numbers on the face of the Bonds. It is expressly provided, however, that the presence or absence of CUSIP numbers on the Bonds shall be of no significance or effect as regards the legality thereof and neither the District nor Bond Counsel to the District are to be held responsible for CUSIP numbers incorrectly printed on the Bonds.

Section 6.03. Legal Opinion. The approving legal opinion of Bond Counsel may be attached to or printed on the reverse side of each definitive Bond over the certification of the Secretary of the Board, which may be executed in facsimile.

ARTICLE VII

SALE AND DELIVERY OF BONDS; DEPOSIT OF PROCEEDS

Section 7.01. Sale of Bonds, Official Statement. (a) The Bonds shall be sold to the Underwriters in accordance with the terms of this Order. As authorized by Chapter 1371, the Authorized Officer is authorized to act on behalf of the District from time to time in selling and delivering the Bonds and in carrying out the other procedures specified in this Order, including determining the price at which each of the Bonds will be sold, the number and designation of each series or subseries of Bonds to be issued, the form in which the Bonds shall be issued, the years and dates on which the Bonds will mature, the principal amount to mature in each of such years, the aggregate principal amount of Bonds to be issued by the District, the rate of interest to be borne by each maturity of the Bonds, the Interest Payment Dates, the dates, prices and terms upon and at which the Bonds shall be subject to redemption prior to maturity at the option of the District and shall be subject to mandatory sinking fund redemption, the selection of the Underwriters, and all other matters relating to the issuance, sale and delivery of the Bonds all of which shall be specified in the Pricing Certificate; subject to the following conditions:

(i) the price to be paid for the Bonds shall not be less than 100% of the aggregate original principal amount of the Bonds plus accrued interest thereon from their date to their delivery;

(ii) the aggregate principal amount of the Bonds authorized to be issued shall not exceed the total maximum principal amount set forth in Section 3.01;

(iii) the Pricing Certificate for the Bonds shall indicate the amount of authorized but unissued bonds that remain available to the District from the applicable voted authorization following the issuance of the Bonds approved in the Pricing Certificate;

(iv) The true interest cost of the Bonds shall not exceed 5.0%, which amount is less than the maximum rate allowed under Section 1204.006, Texas Government Code, as amended; and

(v) no Bond shall mature later than December 31, 2049.

The Authorized Officer is hereby authorized and directed to execute and deliver on behalf of the District a Purchase Contract, providing for the sale of the Bonds to the Underwriters, in such form as determined by the Authorized Officer. The Authorized Officer is hereby authorized and directed to approve the final terms and provisions of the Purchase Contract in accordance with the terms of the Pricing Certificate and this Order, which final terms shall be determined to be the most advantageous reasonably attainable by the District, such approval and determination being evidenced by the execution of the Purchase Contract by the Authorized Officer.

(b) The authority granted to the Authorized Officer under Section 7.01(a) shall expire on a date one (1) year from the date of this Order, unless otherwise extended by the Board by separate action.

(c) All officers, agents and representatives of the District are hereby authorized to do any and all things necessary or desirable to satisfy the conditions set out in the Purchase Contract and to provide for the issuance and delivery of the Bonds. The Initial Bonds shall initially be registered in the name of the Representative or such other entity as may be specified in the Purchase Contract.

(d) The District hereby authorizes the preparation of one or more Preliminary Official Statements for use in the initial offering and sale of the Bonds and authorizes the Authorized Officer to deem the Preliminary Official Statement (with such addenda, supplements or amendments as may be approved by the Authorized Officer) final within the meaning and for the purposes of paragraph (b)(1) of Rule 15c2-12 under the Securities Exchange Act of 1934 on behalf of the District. The District hereby authorizes the preparation of a final Official Statement reflecting the terms of the Purchase Contract and other relevant information. The use of such final Official Statement by the Underwriters (in the form and with such appropriate variations as shall be approved by the Authorized Officer and the Underwriters) is hereby approved and authorized and the proper officials of the District are authorized to sign such Official Statement.

(e) The President or Vice President of the Board, the Secretary of the Board, the Authorized Officer and all other officers of the District are authorized to take such actions, to obtain such consents or approvals, to deliver such notices and to execute such documents, certificates and receipts as they may deem necessary and appropriate in order to consummate the delivery of the Bonds, to pay the costs of issuance of the Bonds, and to effectuate the terms and provisions of this Order, including, without limitation, making application for the guarantee of the permanent school fund for the Bonds from the Texas Education Agency.

Section 7.02. Control and Delivery of Bonds. (a) The Authorized Officer is hereby authorized to have control of the Initial Bonds and all necessary records and proceedings pertaining thereto pending investigation, examination and approval of the Attorney General of the State of Texas, registration by the Comptroller of Public Accounts of the State of Texas, and registration with, and initial exchange or transfer by, the Paying Agent/Registrar.

(b) After registration by the Comptroller of Public Accounts, delivery of the Bonds shall be made to the Representative under and subject to the general supervision and direction of the Authorized Officer, or, in his absence, any officer of the Board, against receipt by the District of all amounts due to the District under the terms of sale.

Section 7.03. Deposit of Proceeds. The proceeds from the sale of the Bonds shall be deposited as set forth in the Pricing Certificate.

ARTICLE VIII

PARTICULAR REPRESENTATIONS AND COVENANTS

Section 8.01. Payment of the Bonds. On or before each date on which Debt Service is due on the Bonds, there shall be made available to the Paying Agent/Registrar, out of the interest and sinking fund, money sufficient to pay such Debt Service when due.

Section 8.02. Other Representations and Covenants. (a) The District will faithfully perform at all times any and all covenants, undertakings, stipulations, and provisions contained in this Order and in each Bond; the District will promptly pay or cause to be paid Debt Service on the dates and at the places and manner prescribed in such Bond; and the District will, at the times and in the manner prescribed by this Order, deposit or cause to be deposited the amounts of money specified by this Order.

(b) The District is duly authorized under the laws of the State of Texas to issue the Bonds; all action on its part for the creation and issuance of the Bonds has been duly and effectively taken; and the Bonds in the hands of the Owners thereof are and will be valid and enforceable obligations of the District in accordance with their terms.

Section 8.03. Federal Income Tax Exclusion.

(a) General. The District intends that the interest on the Bonds be excludable from gross income for federal income tax purposes pursuant to sections 103 and 141 through 150 of the Code. The District covenants and agrees not to take any action, or knowingly omit to take any action within its control, that if taken or omitted, respectively, would (i) cause the interest on

the Bonds to be includable in gross income, as defined in section 61 of the Code, for federal income tax purposes or (ii) result in the violation of or failure to satisfy any applicable provision of section 103 and 141 through 150, inclusive of the Code. In particular, the District covenants and agrees to comply with each requirement of this Section 8.03; provided, however, that the District will not be required to comply with any particular requirement of this Section 8.03 if the District has received an opinion of nationally recognized bond counsel (“Counsel’s Opinion”) that (a) such noncompliance will not adversely affect the exclusion from gross income for federal income tax purposes of interest on the Bonds or (b) compliance with some other requirement will satisfy the applicable requirements of the Code and the Regulations, in which case compliance with such other requirement specified in such Counsel’s Opinion will constitute compliance with the corresponding requirement specified in this Section 8.03.

(b) No Private Use or Payment and No Private Loan Financing. The District covenants and agrees that it will make such use of the proceeds of the Bonds, including interest or other investment income derived from Bond proceeds, regulate the use of property financed directly or indirectly, with such proceeds, and take such other and further action as may be required so that the Bonds will not be “private activity bonds” within the meaning of section 141 of the Code. Moreover, the District will certify, through an authorized officer, employee or agent that, based upon all facts and estimates known or reasonably expected to be in existence on the date the Bonds are delivered, the proceeds of the Bonds will not be used in a manner that would cause the Bonds to be “private activity bonds” within the meaning of section 141 of the Code.

(c) No Federal Guarantee. The District covenants and agrees not to take any action, or knowingly omit to take any action within its control, that, if taken or omitted, respectively, would cause the Bonds to be “federally guaranteed” within the meaning of section 149(b) of the Code, except as permitted by section 149(b)(3) of the Code.

(d) No Hedge Bonds. The District covenants and agrees that it has not and will not take any action, and has not knowingly omitted and will not knowingly omit to take any action, within its control, that, if taken or omitted, respectively, would cause the Bonds to be “hedge bonds” within the meaning of section 149(g) of the Code.

(e) No Arbitrage. The District covenants and agrees that it will make such use of the proceeds of the Bonds, including interest or other investment income derived from Bond proceeds, regulate investments of proceeds of the Bonds, and take such other and further action as may be required so that the Bonds will not be “arbitrage bonds” within the meaning of section 148(a) of the Code. Moreover, the District will certify, through an authorized officer, employee or agent that, based upon all facts and estimates known or reasonably expected to be in existence on the date the Bonds are delivered, the proceeds of the Bonds will not be used in a manner that would cause the Bonds to be “arbitrage bonds” within the meaning of section 148(a) of the Code.

(f) Arbitrage Rebate. If the District does not qualify for an exception to the requirements of section 148(f) of the Code relating to the required rebate to the United States, the District will take all steps necessary to comply with the requirement that certain amounts earned by the District on the investment of the “gross proceeds” of the Bonds (within the meaning of

section 148(f)(6)(B) of the Code), be rebated to the federal government. Specifically, the District will (i) maintain records regarding the investment of the gross proceeds of the Bonds as may be required to calculate the amount earned on the investment of the gross proceeds of the Bonds separately from records of amounts on deposit in the funds and accounts of the District allocable to other bond issues of the District or moneys that do not represent gross proceeds of any bonds of the District, (ii) determine at such times as are required by applicable Regulations, the amount earned from the investment of the gross proceeds of the Bonds which is required to be rebated to the federal government, and (iii) pay, not less often than every fifth anniversary date of the delivery of the Bonds or on such other dates as may be permitted under applicable Regulations, all amounts required to be rebated to the federal government. Further, the District will not indirectly pay any amount otherwise payable to the federal government pursuant to the foregoing requirements to any person other than the federal government by entering into any investment arrangement with respect to the gross proceeds of the Bonds that might result in a reduction in the amount required to be paid to the federal government because such arrangement results in a smaller profit or a larger loss than would have resulted if the arrangement had been at arm's length and had the yield on the issue not been relevant to either party.

(g) Information Reporting. The District covenants and agrees to file or cause to be filed with the Secretary of the Treasury, not later than the 15th day of the second calendar month after the close of the calendar quarter in which the Bonds are issued, an information statement concerning the Bonds, all under and in accordance with section 149(e) of the Code.

(h) Record Retention. The District will retain all pertinent and material records relating to the use and expenditure of the proceeds of the Bonds until three years after the last Bond is redeemed, or such shorter period as authorized by subsequent guidance issued by the Department of the Treasury, if applicable. All records will be kept in a manner that ensures their complete access throughout the retention period. For this purpose, it is acceptable that such records are kept either as hardcopy books and records or in an electronic storage and retrieval system, provided that such electronic system includes reasonable controls and quality assurance programs that assure the ability of the District to retrieve and reproduce such books and records in the event of an examination of the Bonds by the Internal Revenue Service.

(i) Registration. The Bonds will be issued in registered form.

(j) Deliberate Actions. The District will not take a deliberate action (as defined in section 1.141-2(d)(3) of the Regulations) that causes the Bonds to fail to meet any requirement of section 141 of the Code after the issue date of the Bonds unless an appropriate remedial action is permitted by section 1.141-12 of the Regulations, the District takes such remedial action and the District receives a Counsel's Opinion that such remedial action, cures any failure to meet the requirements of section 141 of the Code.

(k) Continuing Obligation. Notwithstanding any other provision of this Order, the District's obligations under the covenants and provisions of this Section 8.03 will survive the defeasance and discharge of the Bonds for as long as such matters are relevant to the exclusion from gross income of interest on the Bonds for federal income tax purposes.

ARTICLE IX

DISCHARGE

Section 9.01. Discharge. The District reserves the right to defease, refund or discharge the Bonds in any manner now or hereafter permitted by law.

ARTICLE X

PERMANENT SCHOOL FUND GUARANTEE

Section 10.01. Permanent School Fund Guarantee. The District will apply for and expects to receive approval from the Texas Commissioner of Education (the “Commissioner”) for payment of the principal of and interest on the Bonds to be guaranteed by the Permanent School Fund of the State of Texas, subject to compliance with the Texas Education Agency’s rules and regulations. If the Bonds are defeased, the guarantee of such series of Bonds will be removed in its entirety and, in case of default and in accordance with Texas Education Code §45.061, the Comptroller of Public Accounts will withhold the amount paid, plus interest, from the first state money payable to the District in the following order: foundation school fund, available school fund. In connection with the guarantee of the Bonds by the Permanent School Fund, the District, hereby certifies and covenants that

(a) a certified copy of this Order and copies of the Official Statement for such series of Bonds shall be furnished to the Division of State Funding, School Facilities and Transportation, within ten (10) calendar days of the date of sale of such series of Bonds;

(b) following any determination by the District that it is or will be unable to pay maturing or matured principal or interest on any such series of Bonds, the District will take all action required by Subchapter C of Chapter 45 of the Texas Education Code, as amended, including, but not limited to, the giving of timely notice of such determination to the Commissioner; and

(c) the District will notify the Division of State Funding in writing within ten (10) calendar days of the defeasance of any guaranteed Bonds.

ARTICLE XI

CONTINUING DISCLOSURE UNDERTAKING

Section 11.01. Annual Reports. (a) The District shall provide annually to the MSRB, (i) within six (6) months after the end of each Fiscal Year of the District ending in or after 2017, financial information and operating data with respect to the District of the general type included in the Official Statement, being the information described in the Pricing Certificate, and (ii) if not provided as part such financial information and operating data, audited financial statements of the District, when and if available. Any financial statements so to be provided shall be (i) prepared in accordance with the accounting principles prescribed by the Texas State Board of Education or such other accounting principles as the District may be required to employ, from

time to time, by State law or regulation, and (ii) audited, if the District commissions an audit of such statements and the audit is completed within the period during which they must be provided. If the audit of such financial statements is not complete within 12 months after any such fiscal year end, then the District shall file unaudited financial statements within such 12-month period and audited financial statements for the applicable fiscal year, when and if the audit report on such financial statements becomes available.

(b) If the District changes its Fiscal Year, it will notify the MSRB of the change (and of the date of the new Fiscal Year end) prior to the next date by which the District otherwise would be required to provide financial information and operating data pursuant to this Section.

(c) The financial information and operating data to be provided pursuant to this Section may be set forth in full in one or more documents or may be included by specific reference to any document (including an official statement or other offering document), if it is available to the public on the MSRB's Internet website or has been filed with the SEC. The financial information or operating data shall be provided in an electronic format as prescribed by the MSRB.

Section 11.02. Event Notices.

(a) The District shall provide the following to the MSRB, in an electronic format as prescribed by the MSRB, in a timely manner not in excess of ten (10) business days after the occurrence of the event, notice of any of the following events with respect to the Bonds:

- (1) Principal and interest payment delinquencies;
- (2) Non-payment related defaults, if material;
- (3) Unscheduled draws on debt service reserves reflecting financial difficulties;
- (4) Unscheduled draws on credit enhancements reflecting financial difficulties;
- (5) Substitution of credit or liquidity providers, or their failure to perform;
- (6) Adverse tax opinions, the issuance by the Internal Revenue Service of proposed or final determinations of taxability, Notices of Proposed Issue (IRS Form 5701-TEB) or other material notices or determinations with respect to the tax status of the Bonds, or other material events affecting the tax status of the Bonds;
- (7) Modifications to rights of the holders of the Bonds, if material;
- (8) Bond calls, if material, and tender offers;

- (9) Defeasances;
- (10) Release, substitution, or sale of property securing repayment of the Bonds, if material;
- (11) Rating changes;
- (12) Bankruptcy, insolvency, receivership or similar event of the District;

Note to paragraph 12: For the purposes of the event identified in paragraph 12 of this section, the event is considered to occur when any of the following occur: the appointment of a receiver, fiscal agent or similar officer for the District in a proceeding under the U.S. Bankruptcy Code or in any other proceeding under state or federal law in which a court or governmental authority has assumed jurisdiction over substantially all of the assets or business of the District, or if such jurisdiction has been assumed by leaving the existing governing body and officials or officers in possession but subject to the supervision and orders of a court or governmental authority, or the entry of an order confirming a plan of reorganization, arrangement or liquidation by a court or governmental authority having supervision or jurisdiction over substantially all of the assets or business of the District.

(13) The consummation of a merger, consolidation, or acquisition involving the District or the sale of all or substantially all of the assets of the District, other than in the ordinary course of business, the entry into a definitive agreement to undertake such an action or the termination of a definitive agreement relating to any such actions, other than pursuant to its terms, if material; and

(14) Appointment of successor or additional paying agent/registrar or the change of name of a paying agent/registrar, if material.

(b) The District shall provide to the MSRB, in an electronic format as prescribed by the MSRB, in a timely manner, notice of a failure by the District to provide financial information and operating data in accordance with Section 11.01. All documents provided to the MSRB pursuant to this section shall be accompanied by identifying information as prescribed by the MSRB.

Section 11.03. Limitations, Disclaimers and Amendments. (a) The District shall be obligated to observe and perform the covenants specified in this Article for so long as, but only for so long as, the District remains an “obligated person” with respect to the Bonds within the meaning of the Rule, except that the District in any event will give notice of any deposit made in accordance with Article IX that causes Bonds no longer to be outstanding.

(b) The provisions of this Article are for the sole benefit of the Owners and beneficial owners of the Bonds, and nothing in this Article, express or implied, shall give any benefit or any legal or equitable right, remedy, or claim hereunder to any other person. The District undertakes to provide only the financial information, operating data, financial statements, and notices which it has expressly agreed to provide pursuant to this Article and does not hereby undertake to provide any other information that may be relevant or material to a complete presentation of the District's financial results, condition, or prospects or hereby undertake to update any information provided in accordance with this Article or otherwise, except as expressly provided herein. The District does not make any representation or warranty concerning such information or its usefulness to a decision to invest in or sell Bonds at any future date.

UNDER NO CIRCUMSTANCES SHALL THE DISTRICT BE LIABLE TO THE OWNER OR BENEFICIAL OWNER OF ANY BOND OR ANY OTHER PERSON, IN CONTRACT OR TORT, FOR DAMAGES RESULTING IN WHOLE OR IN PART FROM ANY BREACH BY THE DISTRICT, WHETHER NEGLIGENT OR WITH OR WITHOUT FAULT ON ITS PART, OF ANY COVENANT SPECIFIED IN THIS ARTICLE, BUT EVERY RIGHT AND REMEDY OF ANY SUCH PERSON, IN CONTRACT OR TORT, FOR OR ON ACCOUNT OF ANY SUCH BREACH SHALL BE LIMITED TO AN ACTION FOR MANDAMUS OR SPECIFIC PERFORMANCE.

(c) No default by the District in observing or performing its obligations under this Article shall comprise a breach of or default under the Order for purposes of any other provisions of this Order.

(d) Nothing in this Article is intended or shall act to disclaim, waive, or otherwise limit the duties of the District under federal and state securities laws.

(e) The provisions of this Article may be amended by the District from time to time to adapt to changed circumstances that arise from a change in legal requirements, a change in law, or a change in the identity, nature, status, or type of operations of the District, but only if (1) the provisions of this Article, as so amended, would have permitted an underwriter to purchase or sell Bonds in the primary offering of the Bonds in compliance with the Rule, taking into account any amendments or interpretations of the Rule to the date of such amendment, as well as such changed circumstances, and (2) either (A) the Owners of a majority in aggregate principal amount (or any greater amount required by any other provisions of this Order that authorizes such an amendment) of the outstanding Bonds consent to such amendment or (B) a person that is unaffiliated with the District (such as nationally recognized bond counsel) determines that such amendment will not materially impair the interests of the Owners and beneficial owners of the Bonds. The District may also repeal or amend the provisions of this Section if the SEC amends or repeals the applicable provisions of the Rule or any court of final jurisdiction enters judgment that such provisions of the Rule are invalid, and the District also may amend the provisions of this Section in its discretion in any other manner or circumstance, but in either case only if and to the extent that the provisions of this sentence would not have prevented an underwriter from lawfully purchasing or selling the Bonds in the primary offering of the Bonds, giving effect to (a) such provisions as so amended and (b) any amendments or interpretations of the Rule. If the District so amends the provisions of this Article, the District shall include with any amended financial information or operating data next provided in

accordance with this Article an explanation, in narrative form, of the reasons for the amendment and of the impact of any change in the type of financial information or operating data so provided.

ARTICLE XII

MISCELLANEOUS

Section 12.01. Changes to Order. The Authorized Officer, in consultation with Bond Counsel, is hereby authorized to make changes to the terms of this Order if necessary or desirable to carry out the purposes hereof or in connection with the approval of the issuance of the Bonds by the Attorney General of Texas.

Section 12.02. Partial Invalidity. If any section, paragraph, clause or provision of this Order shall for any reason be held to be invalid or unenforceable, the invalidity or unenforceability of such section, paragraph, clause or provision shall not affect any of the remaining provisions of this Order.

Section 12.03. No Personal Liability. No recourse shall be had for payment of the principal of or interest on any Bonds or for any claim based thereon, or on this Order, against any official or employee of the District or any person executing any Bonds.

Section 12.04. Related Matters. To satisfy in a timely manner all of the District's obligations under this Order, the President or Vice President of the Board and the Secretary of the Board and all other appropriate officers and agents of the District are hereby authorized and directed to do any and all things necessary and/or convenient to carry out the terms and purposes of this Order.

Section 12.05. Force and Effect. This Order shall be in full force and effect from and after its final passage, and it is so ordered.

[Signature Page Follows]

PASSED, APPROVED AND EFFECTIVE on December 15, 2016.

Secretary, Board of Trustees
Lamar Consolidated Independent School
District

President, Board of Trustees
Lamar Consolidated Independent School
District

[SEAL]

of the interest payment date, mailed by the Paying Agent/Registrar to the registered owner at the address shown on the registration books kept by the Paying Agent/Registrar, or by such other customary banking arrangements acceptable to the Paying Agent/Registrar and the person to whom interest is to be paid; provided, however, that such person shall bear all risk and expense of such other customary banking arrangements. For the purpose of the payment of interest on this Bond, the registered owner shall be the person in whose name this Bond is registered at the close of business on the "Record Date," which shall be the ⁶ business day of the month next preceding such interest payment date. In the event of a nonpayment of interest on a scheduled payment date, and for 30 days thereafter, a new record date for such interest payment (a "Special Record Date") will be established by the Paying Agent/Registrar, if and when funds for the payment of such interest have been received from the District. Notice of the Special Record Date and of the special payment date of the past due interest (the "Special Payment Date," which date shall be 15 days after the Special Record Date) shall be sent at least five (5) business days prior to the Special Record Date by United States mail, first class, postage prepaid, to the address of each owner of a Bond appearing on the books of the Paying Agent/Registrar at the close of business on the last day next preceding the date of mailing of such notice.

If the date for the payment of the principal of or interest on this Bond shall be a Saturday, Sunday, legal holiday, or day on which banking institutions in the city where the Paying Agent/Registrar is located are required or authorized by law or executive order to close, the date for such payment shall be the next succeeding day which is not a Saturday, Sunday, legal holiday, or day on which banking institutions are required or authorized to close, and payment on such date shall for all purposes be deemed to have been made on the original date payment was due.

This Bond is one of a series of fully registered bonds specified in the title hereof, dated as of ⁷, issued in the aggregate principal amount of \$ ⁸ (herein referred to as the "Bonds"), issued pursuant to a certain order (the "Bond Order") adopted by the Board of Trustees of the District and a pricing certificate executed pursuant to the Bond Order (the "Pricing Certificate," and, together with the Bond Order, the "Order"), for the purposes of the construction, acquisition and equipment of school buildings in the District; for the purchase of the necessary sites for school buildings and the purchase of new school buses; and to pay the costs of issuing the Bonds.

The Bonds and the interest thereon are payable from the proceeds of a direct and continuing ad valorem tax levied, without limit as to rate or amount, against all taxable property in the District sufficient, together with certain available funds of the District on deposit in the interest and sinking fund for the Bonds, to provide for the payment of the principal of and interest on the Bonds, as described and provided in the Order.

The District has reserved the option to redeem the Bonds maturing on and after ⁹, in whole or in part before their respective scheduled maturity dates, on ¹⁰, or on any date

⁶ Insert from Pricing Certificate.

⁷ Insert from Pricing Certificate.

⁸ Insert from Pricing Certificate.

⁹ Insert from Pricing Certificate.

¹⁰ Insert from Pricing Certificate.

thereafter, at a redemption price equal to the principal amount thereof plus accrued interest to the date of redemption. If less than all of the Bonds are to be redeemed, the District shall determine the maturity or maturities and the amounts thereof to be redeemed and shall direct the Paying Agent/Registrar to call by lot or other method that results in random selection the Bonds, or portions thereof, within such maturity and in such principal amounts, for redemption.

[Bonds maturing on _____¹¹ (the “Term Bonds”) are subject to mandatory sinking fund redemption prior to their scheduled maturity, and will be redeemed by the District, in part at a redemption price equal to the principal amount thereof, without premium, plus interest accrued to the redemption date, on the dates and in the principal amounts shown in the following schedule:

<u>\$ _____¹² Term Bonds Maturing _____¹³</u>	
<u>Redemption Date</u>	<u>Principal Amount</u>
_____ ¹⁴	\$ _____ ¹⁵

The Paying Agent/Registrar will select for redemption by lot, or by any other customary method that results in a random selection the specific Term Bonds (or with respect to Term Bonds having a denomination in excess of \$5,000, each \$5,000 portion thereof) to be redeemed by mandatory redemption. The principal amount of Term Bonds required to be redeemed on any redemption date pursuant to the foregoing mandatory sinking fund redemption provisions hereof shall be reduced, at the option of the District, by the principal amount of any Term Bonds which, at least 45 days prior to the mandatory sinking fund redemption date (i) shall have been acquired by the District at a price not exceeding the principal amount of such Term Bonds plus accrued interest to the date of purchase thereof, and delivered to the Paying Agent/Registrar for cancellation, or (ii) shall have been redeemed pursuant to the optional redemption provisions hereof and not previously credited to a mandatory sinking fund redemption.]¹⁶

Not less than 30 days prior to a redemption date for the Bonds, the District shall cause a notice of redemption to be sent by United States mail, first class, postage prepaid, to the Owners of the Bonds to be redeemed at the address of the Owner appearing on the registration books of the Paying Agent/Registrar at the close of business on the business day next preceding the date of mailing such notice.

In the Order, the District reserves the right, in the case of an optional redemption, to give notice of its election or direction to redeem Bonds conditioned upon the occurrence of subsequent events. Such notice may state (i) that the redemption is conditioned upon the deposit of moneys and/or authorized securities, in an amount equal to the amount necessary to effect the redemption, with the Paying Agent/Registrar, or such other entity as may be authorized by law, no later than the redemption date, or (ii) that the District retains the right to rescind such notice at

¹¹ Insert from Pricing Certificate.
¹² Insert from Pricing Certificate.
¹³ Insert from Pricing Certificate.
¹⁴ Insert from Pricing Certificate.
¹⁵ Insert from Pricing Certificate.
¹⁶ Delete if Term Bonds are not issued.

any time on or prior to the scheduled redemption date if the District delivers a certificate of the District to the Paying Agent/Registrar instructing the Paying Agent/Registrar to rescind the redemption notice, and such notice and redemption shall be of no effect if such moneys and/or authorized securities are not so deposited or if the notice is rescinded. The Paying Agent/Registrar shall give prompt notice of any such rescission of a conditional notice of redemption to the affected Owners. Any Bonds subject to conditional redemption and such redemption has been rescinded shall remain Outstanding. Any notice so mailed shall be conclusively presumed to have been duly given, whether or not the registered owner receives such notice. Notice having been so given and subject, in the case of an optional redemption, to any rights or conditions reserved by the District in the notice, the Bonds called for redemption shall become due and payable on the specified redemption date, and notwithstanding that any Bond or portion thereof has not been surrendered for payment, interest on such Bonds or portions thereof shall cease to accrue.

As provided in the Order, and subject to certain limitations therein set forth, this Bond is transferable upon surrender of this Bond for transfer at the Designated Payment/Transfer Office of the Paying Agent/Registrar with such endorsement or other evidence of transfer as is acceptable to the Paying Agent/Registrar; thereupon, one or more new fully registered Bonds of the same stated maturity, of authorized denominations, bearing the same rate of interest, and for the same aggregate principal amount will be issued to the designated transferee or transferees.

Neither the District nor the Paying Agent/Registrar shall be required to transfer or exchange any Bond called for redemption where such redemption is scheduled to occur within 45 calendar days after the transfer or exchange date; provided, however, such limitation shall not be applicable to an exchange by the registered owner of the uncalled principal balance of a Bond.

The District, the Paying Agent/Registrar, and any other person may treat the person in whose name this Bond is registered as the owner hereof for the purpose of receiving payment as herein provided (except interest shall be paid to the person in whose name this Bond is registered on the Record Date) and for all other purposes, whether or not this Bond be overdue, and neither the District nor the Paying Agent/Registrar shall be affected by notice to the contrary.

IT IS HEREBY CERTIFIED AND RECITED that the issuance of this Bond and the series of which it is a part is duly authorized by law; that all acts, conditions and things required to be done precedent to and in the issuance of the Bonds have been properly done and performed and have happened in regular and due time, form and manner, as required by law; that sufficient and proper provision for the levy and collection of taxes has been made, without limit as to rate or amount, which when collected shall be appropriated exclusively to the timely payment of the principal of and interest on the Bonds; and that the total indebtedness of the District, including the Bonds, does not exceed any constitutional or statutory limitation.

IN WITNESS WHEREOF, the District has caused this Bond to be duly executed under its official seal in accordance with law.

Secretary, Board of Trustees
Lamar Consolidated Independent School

President, Board of Trustees
Lamar Consolidated Independent School

District

District

[SEAL]

(b) Form of Certificate of Paying Agent/Registrar

CERTIFICATE OF PAYING AGENT/REGISTRAR

This is one of the Bonds referred to in the within mentioned Order. The series of Bonds of which this Bond is a part was originally issued as one Initial Bond which was approved by the Attorney General of the State of Texas and registered by the Comptroller of Public Accounts of the State of Texas.

_____¹⁷,
as Paying Agent/Registrar

Date: _____ By: _____

(c) Form of Assignment

ASSIGNMENT

FOR VALUE RECEIVED, the undersigned hereby sells, assigns and transfers unto (print or typewrite name, address and zip code of transferee):

(Social Security or other identifying number: _____) the within Bond and all rights hereunder and hereby irrevocably constitutes and appoints _____ attorney to transfer the within Bond on the books kept for registration hereof, with full power of substitution in the premises.

Dated: _____

Signature Guaranteed By:

Authorized Signatory

NOTICE: The signature on this Assignment must correspond with the name of the registered owner as it appears on the face of the within Bond in every particular and must be guaranteed in a manner acceptable to the Paying Agent/Registrar.

(d) Statement of Permanent School Fund Guarantee.

The following statement shall appear on or be attached to each Bond:

¹⁷ Insert from Pricing Certificate.

PSF CERTIFICATE

Under the authority granted by Article 7, Section 5 of the Texas Constitution and Subchapter C of Chapter 45 of the Texas Education Code, the payment, when due, of the principal of and interest on the issuance by the Cypress Fairbanks Independent School District of its Unlimited Tax Schoolhouse Bonds, Series 2017, dated _____¹⁸, in the principal amount of \$_____¹⁹ is guaranteed by the corpus of the Permanent School Fund of the State pursuant to the bond guarantee program administered by the Texas Education Agency. This guarantee shall be removed in its entirety upon defeasance of such bonds.

Reference is hereby made to the continuing disclosure agreement of the Texas Education Agency, set forth in Section I of the Agency’s Investment Procedure Manual and the Agency’s commitment letter for the guarantee. Such disclosure agreement has been made with respect to the bond guarantee program, in accordance with Rule 15c2-12 of the United States Securities and Exchange Commission, for the benefit of the holders and beneficial owners of the bonds.

In witness thereof I have caused my signature to be placed in facsimile on this bond.



Mike Morath
Commissioner of Education

(e) Initial Bond Insertions

The Initial Bond shall be in the form set forth in paragraphs (a), (c) and (d) of this Section, except that, in the event there is more than one maturity of Bonds:

(1) immediately under the name of the Bond, the headings “INTEREST RATE” and “MATURITY DATE” shall both be completed with the words “As Shown Below” and “CUSIP NO. _____” deleted;

(2) in the first paragraph the words “on the Maturity Date specified above, the sum of _____ DOLLARS” shall be deleted and the following will be inserted: “on _____²⁰ in the years, in the principal installments and bearing interest at the per annum rates set forth in the following schedule:

<u>Year</u>	<u>Principal Amount</u>	<u>Interest Rate</u>
-------------	-------------------------	----------------------

(Information to be inserted from the Pricing Certificate); and

¹⁸ Insert from Pricing Certificate.

¹⁹ Insert from Pricing Certificate.

²⁰ Insert from Pricing Certificate.

(3) the Initial Bond shall be numbered I-1.

(4) The following Registration Certificate of Comptroller of Public Accounts shall appear on the Initial Bond:

REGISTRATION CERTIFICATE OF
COMPTROLLER OF PUBLIC ACCOUNTS

OFFICE OF THE COMPTROLLER §
OF PUBLIC ACCOUNTS § REGISTER NO. _____
THE STATE OF TEXAS §

I HEREBY CERTIFY THAT there is on file and of record in my office a certificate to the effect that the Attorney General of the State of Texas has approved this Bond, and that this Bond has been registered this day by me.

WITNESS MY SIGNATURE AND SEAL OF OFFICE this _____

[SEAL]

Comptroller of Public Accounts
of the State of Texas

CERTIFICATE FOR ORDER

THE STATE OF TEXAS §
COUNTY OF FORT BEND §

I, the undersigned officer of the Board of Trustees of Lamar Consolidated Independent School District, hereby certify as follows:

1. The Board of Trustees of Lamar Consolidated Independent School District convened in regular meeting on the 15th day of December, 2016, at the regular meeting place thereof, within said District, and the roll was called of the duly constituted officers and members of said Board, to wit:

James Steenberg	President
Kathryn Kaminski	Vice President
Kay Danziger	Secretary
Anna Gonzales	Trustee
Dr. Tyson Harrell	Trustee
Melisa Roberts	Trustee
Frank Torres	Trustee

and all of said persons were present, except the following absentee(s): _____, thus constituting a quorum. Whereupon, among other business, the following was transacted at said meeting: a written

ORDER AUTHORIZING THE ISSUANCE OF LAMAR CONSOLIDATED INDEPENDENT SCHOOL DISTRICT UNLIMITED TAX SCHOOLHOUSE BONDS, SERIES 2017; APPROVING THE PREPARATION OF AN OFFICIAL STATEMENT; AND ENACTING OTHER PROVISIONS RELATING THERETO

was duly introduced for the consideration of said Board and read in full. It was then duly moved and seconded that said order be adopted; and, after due discussion, said motion, carrying with it the adoption of said order, prevailed and carried by the following vote:

_____ Member(s) shown present voted "Aye."

_____ Member(s) shown present voted "No."

2. A true, full and correct copy of the aforesaid order adopted at the meeting described in the above and foregoing paragraph is attached to and follows this certificate; that said order has been duly recorded in said Board's minutes of said meeting; that the above and foregoing paragraph is a true, full and correct excerpt from said Board's minutes of said meeting pertaining to the adoption of said order; that the persons named in the above and foregoing paragraph are the duly chosen, qualified and acting officers and members of said Board as indicated therein; that each of the officers and members of said Board was duly and sufficiently notified officially and personally, in advance, of the date, hour, place and purpose of the aforesaid meeting, and that said order would be introduced and considered for adoption at said meeting, and each of said officers and members consented, in advance, to the holding of said meeting for such purpose; that said meeting was open to the public as required by law; and that public notice of the date, hour, place and subject of said meeting was given as required by the Chapter 551, Texas Government Code.

SIGNED AND SEALED this 15th day of December, 2016.

Secretary, Board of Trustees
Lamar Consolidated Independent
School District

[SEAL]

**CONSIDER APPROVAL OF MASTER INTERLOCAL AGREEMENT WITH
REGION 10 EDUCATION SERVICE CENTER FOR PRODUCTS
AND SERVICES RELATED TO EDUPHORIA**

RECOMMENDATION:

That the Board of Trustees approve the renewal agreement for Eduphoria Premium Suite subscription services through Region 10 Education Service Center, and authorize the Superintendent to execute the service agreement/interlocal agreement as well as subsequent service renewal agreements/interlocal agreements related to this service.

IMPACT/RATIONALE:

This renewal provided via an interlocal agreement allows Lamar CISD Research, Assessment and Accountability Department to continue to receive subscription services annually. Other departments that rely on this service include: Curriculum and Instruction, Staff Development and Human Resources. The services are currently being offered for January 2017 through December 31, 2017. Pricing will be fixed through the year 2020 if the District is in agreement with overall pricing, fluctuating only as campus sites are added.

PROGRAM DESCRIPTION:

Upon approval, the Superintendent will execute the agreements annually which will allow for continued services to be obtained by the District at the discounted rate of \$1,995 per campus.

The Eduphoria Premium Suite provides the District and campuses STAAR and other state testing results, provides rostering, online scanning abilities, and advanced data integration of local assessment data with state data. Additionally, the system houses the district curriculum, lesson planning, staff development records, and employee appraisal records. The current rate of the 2017 subscription is \$75,810.00 for 38 units.

Submitted by: Brian Moore, Director of Research, Assessment & Accountability
 Valerie Vogt, Academic Administrator
 Jill Ludwig, CPA, RTSBA, Chief Financial Officer
 Michele Leach, RTSBA, Purchasing and Materials Manager

Recommended for approval:

Thomas Randle

Dr. Thomas Randle
Superintendent

Eduphoria Premium Suite Annual Subscription - 2017



Description: Agreement between ESC Region 10 and Lamar CISD for purchase of the Eduphoria Premium Suite

Duration of Service: January 1, 2017 to December 31, 2017

The **Eduphoria Premium Suite** provides the district's and campus's STAAR and other state testing results with easy access for teachers to view data in many formats. It also provides student rostering, scanning abilities online, and advanced data integration of local assessment data with state data. **Aware**, also includes the ability to create forms, complete forms on individual students and warehouse a variety of local data within the same web-based system. The **Premium Suite** also includes the full range of Eduphoria products: Workshop, Facilities and Events, Formspace, Appraise, Helpdesk, and the Forethought curriculum management system. (See additional information below.)

Pursuant to the Interlocal Cooperation Act, Chapter 791 of the Texas Government Code, this Interlocal Contract (the "Contract") is made and entered into between ESC Region10 and Lamar CISD for the purpose of performing governmental functions and services and to state the terms, rights, and duties of the Contracting parties from January 1, 2017 to December 31, 2017.

Arrangement

ESC 10 agrees to provide the products and services described below. Lamar ISO agrees to pay for the products and services within thirty (30) days of receiving an invoice for the products and services.

<u>Type(s) of Products/Services(s)</u>	<u>Units</u>	<u>Price</u>	<u>Item Cost</u>
Eduphoria Premium Suite Annual Subscription	38	\$1,995.00	\$75,810.00
Total Cost			\$75,810.00

District Contact (for this program):

Contact Name: Brian D. Moore, M.Ed. Tech.
 Contact Phone: (832) 223-0136
 Contact Email: bmoore@lcisd.org

Approval Information:

District Superintendent or Designee

Thomas Randle

Date: 11-17-16

Region 10 ESC, Executive Director

Dr. Gordon Taylor

Date: 11-16-16

Additional Info:

Eduphoria Suite includes all of the following Eduphoria applications with training and support provided by Region 10*.

Aware-Data Analysis and Student Data Management

Forethought-Curriculum and Lesson Planning

PDAS/Appraise-Staff evaluation system (including T-TESS/T-PESS)

Helpdesk-Ticket Request and Management

Formspace-Paperless Forms with Workflow

Facilities & Events-Reservations and Inventory Management

Workshop-Professional Development registration and tracking system

*LEAs who purchase Eduphoria applications through Region 10 will receive training and support on purchased applications at no additional cost. Out-of-Region LEAs who purchase Eduphoria applications through Region 10 will receive training and support on purchased applications and will only have to pay for travel costs for trainers.

CONSIDER APPROVAL OF DONATIONS TO THE DISTRICT

RECOMMEDATION:

That the Board of Trustees approve donations to the District.

IMPACT/RATIONALE:

Policy CDC (Local) states that the Board of Trustees must approve any donation with a value in excess of \$2,500.

PROGRAM DESCRIPTION:

Frost Elementary PTO donated \$7,417.30 to purchase reading materials for Frost Elementary School.

Meyer Elementary PTO donated \$5,000 to be used for educational field trips for Meyer Elementary School.

Recommended for approval:



Dr. Thomas Randle
Superintendent

CONSIDER APPROVAL OF BOARD POLICIES

RECOMMENDATION:

That the Board of Trustees approve second reading of the following policies:

- Localized Policy Manual Update 105
- Localized Policy Manual Update 106
- CDC (LOCAL) Other Revenues: Grants from private sources
- DK (LOCAL) Assignments and Schedules

PROGRAM DESCRIPTION:

A primary function of the Board of Trustees is to adopt policies for the operation of the District. Local policies are customized to provide a procedure to enforce the legal policies and District guidelines.

Recommended for approval:



Dr. Thomas Randle
Superintendent

CONSIDER APPROVAL OF ATTENDANCE BOUNDARY COMMITTEE

RECOMMENDATION:

That the Board of Trustees approve the membership of the Attendance Boundary Committee (ABC) for 2016-2017 as presented with the proposed timeline using the LCISD Zoning Process, and charge the ABC with setting the boundaries for Lindsey Elementary for the 2017-2018 school year.

IMPACT/RATIONALE:

Membership of the ABC will consist of two representatives from Huggins Elementary and three representatives each from Leaman Junior High and Fulshear High—as specified in the LCISD Zoning Process, approved by the Board in September 2004. The LCISD Zoning Process states that only representatives from campuses affected by rezoning and their feeder schools will be involved in making the rezoning recommendations to the Board. Current Board members cannot serve on the ABC.

Attached you will find the LCISD Zoning Process and a tentative timeline for the 2016-2017 ABC. Using this timeline, zoning decisions for Lindsey Elementary would be finalized by February or March.

Submitted by: Mike Rockwood, Executive Director of Community Relations

Recommended for approval:



Dr. Thomas Randle
Superintendent

2016-2017 Lindsey Attendance Boundary Committee

CAMPUS	FIRST	LAST	HOME ADDRESS	City	PHONE NUMBER	EMAIL
Elementary						
Huggins Elementary	Carrie	Crowley	2815 Frasier Knolls Court	Katy	(713) 854-5303	carriecrowley2003@yahoo.com
Huggins Elementary	Beth	Skeen	5402 Westerdale Drive	Fulshear	(832) 283-2850	bdskeen@yahoo.com
Junior High						
Leaman Junior High	Rylee	Burton	32611 Wedmore Place	Fulshear	(832) 877-0466	ryleeburton@live.com
Leaman Junior High	Daniel	McRea	30823 Spanish Moss Crossing	Fulshear	(713) 825-8245	dmcrea@summitmidstream.com
Leaman Junior High	Michele	Frietsch	33103 Whickham Circle	Fulshear	(281) 881-2964	mfrietsch@ldry.com
High						
Fulshear High	Lisa	Escobedo	600 Chisolm	Simonton	(281) 797-9168	the6escobedos@aol.com
Fulshear High	Melody	Holmes	11110 Lombardia Court	Richmond	(281) 728-9865	mholmes413@gmail.com
Fulshear High	Rosie	Kuhar	11618 Lantana Reach Drive	Richmond	(281) 840-8277	rosiekuhar@gmail.com

2016 - 2017 Attendance Boundary Committee Zoning Timeline for Lindsey Elementary

October 20	Information item with timeline to Board
November 1	Request for Attendance Boundary Committee (ABC) applications
December 2	Deadline for principals to submit ABC representatives
December 13	Board Zoning Committee meeting
December 14	Attendance boundary review for Lindsey Elementary at facilities planning team meeting
December 15	Board approval of ABC and charge to ABC
January 2	First ABC meeting – zoning considerations for fall 2017 – 7 p.m. Board Room
January 9	Second ABC meeting – zoning considerations for fall 2017 – 7 p.m. Board Room
January 18	Third ABC meeting (if needed) – zoning considerations for fall 2016 – 7 p.m. Board Room
January 23	Public input at community meeting – TBD – 7 p.m.
February 6	ABC meeting – zoning recommendation to the Board finalized for fall 2017 – 7 p.m. Board Room
February 14	ABC recommendation to the Board Zoning Committee
February 16	ABC recommendation to the Board – 7 p.m. Board Room
February 20	Information sent out to parents of students rezoned (if approved by Board)
March 23	ABC recommendation to the Board/additional public input/Board discussion if not approved at the February meeting – 7 p.m. Board Room

THE LCISD ZONING PROCESS

FACT: Lamar CISD is among the fastest growing school districts in the state. A large number of residential developments are under construction or in the planning stages throughout the LCISD community. The district must continue providing all students with a quality education.

BACKGROUND: In a growing school system, it is inevitable that the district's attendance zones will be changed periodically. As new schools open and population shifts occur, attendance zones will be adjusted. Each campus in the district is unique and offers many enrichment opportunities for students. Our goal is to ensure that all campuses, regardless of location, provide quality programs.

REQUESTING AN INTRA-DISTRICT TRANSFER: Assignments of any neighborhoods or areas of the district to a particular campus are subject to re-evaluation each year. Although students are expected to attend the school located in the attendance zone in which they reside, certain conditions may exist as outlined in district policies and procedures in which parents/guardians may request their child's transfer to another LCISD campus. In such instances, the parents/guardians may complete an intra-district transfer application available from any campus.

The application must be submitted to the principal at the requested campus. Due to overcrowded conditions at some campuses, the district may declare a campus closed to new transfers.

ZONING OBJECTIVES/CRITERIA: The district's Framework for Facilities Planning established a need for objectives and criteria to be used to guide zoning decisions. The following 12 objectives should be used when developing new attendance zones. All of the 12 objectives should be given equal weight when making boundary decisions.

1. To draw attendance zones in a way that supports an efficient/effective use of school facilities.
2. To reduce overcrowding of campuses.
3. To plan for future growth.
4. To keep neighborhoods and feeder schools tracking together, as much as possible.
5. To minimize rezoning neighborhoods which have been affected in previous rezonings.
6. To draw secondary zones which reflect the diversity of the district, as much as possible.
7. To consider elementary students' proximity to a campus, being mindful of traffic patterns that allow for the safest routes available.
8. To involve the community in defining the objectives/criteria for rezoning.
9. To develop a fair and objective rezoning process.
10. To always keep in mind doing what is in the best interest of students.
11. To communicate zoning information effectively to all students and families that may be impacted.
12. To consider fiscal impact of changes.

ATTENDANCE BOUNDARY COMMITTEE MAKE-UP: Membership of the ABC will consist of two representatives from each elementary and middle school campus and three representatives from each junior high and high school campus. The campus administrator will select campus representatives with the entire committee approved by the Board. Appropriate central administrators will serve as resources as needed. District information and the Board’s charge for rezoning considerations will be presented to the entire committee. Only representatives from campuses affected by rezoning and their feeder schools will be involved in making the rezoning recommendations to be presented to the Board. Current Board members cannot serve on the Attendance Boundary Committee.

LCISD ZONING PROCESS

Step 1	Step 2	Step 3	Step 4	Step 5	Step 6	Step 7
Conduct Board/Cabinet workshop(s) to review and discuss ABC charge and approve committee membership.	Convene the Attendance Boundary Committee (ABC) to review data & create zoning recommendations based on options presented by the administration as charged by the Board.	Conduct community forum(s) for parents in the areas subject to change to review plans and provide feedback.	Conduct additional ABC meetings as needed to review and discuss ABC proposed plan(s), and any changes presented based on parent input.	Conduct additional community forum(s) if needed to present final recommendation and allow for public comments.	Submit final recommendation to the Board Zoning Committee for input.	Submit final recommendation for Board approval.

Step 1: The administrative team will present all options to be considered for rezoning for review, discussion and input at a Board workshop (open to the public). Any modifications suggested at the workshop will be made before presenting the options to the ABC. Information for the Board may also be presented in written format to be discussed at a regular meeting of the Board. The Board will charge the administration with rezoning priorities to be considered by the ABC and approve the ABC membership roster for that year.

Step 2: Involve parents and community members in the process through the district Attendance Boundary Committee (ABC). The ABC will review the supporting data and options presented by the administration and work to propose possible zoning recommendations for Board consideration and approval.

Step 3: The plan(s) will be shown at a Community Forum(s) for parent input.

Step 4: Based on parent input from the Community Forum(s), the ABC will make any needed modifications to its recommendations. Modified ABC recommendations can be presented orally or in a written format to the Board.

Step 5: Additional Community Forum if needed to allow for parent comments on any ABC changes to the original recommendation.

Step 6: ABC will submit final recommendation to the Board Zoning Committee for input.

Step 7: Zoning plan(s) submitted for Board approval.

ADDITIONAL INFORMATION: If you would like additional information about zoning in Lamar CISD, please contact Community Relations at 832-223-0330.

**CONSIDER APPROVAL OF CENTERPOINT ENERGY AERIAL EASEMENT
FOR BENTLEY ELEMENTARY SCHOOL**

RECOMMENDATION:

That the Board of Trustees approve the CenterPoint Energy aerial easement for electric transmission and distribution lines at Bentley Elementary School and authorize the Board President to execute easement documents.

IMPACT/RATIONALE:

The permanent aerial easement to CenterPoint Energy is for the overhead electric transmission lines along FM 359 as part of the roadway widening project for Bentley Elementary School. This easement affects the southwestern corner of the site.

PROGRAM DESCRIPTION:

Upon approval, CenterPoint Energy will record the permanent aerial easement for the electric transmission lines along the southwest portion of the Bentley Elementary School site.

Submitted By: Kevin McKeever, Administrator for Operations
 Steve Hoyt, Vanir/Rice & Gardner Consultants, Inc., A Joint Venture

Recommended for approval:

Thomas Randle

Dr. Thomas Randle
Superintendent

AERIAL EASEMENT

NOTICE OF CONFIDENTIALITY RIGHTS: IF YOU ARE A NATURAL PERSON, YOU MAY REMOVE OR STRIKE ANY OR ALL OF THE FOLLOWING INFORMATION FROM ANY INSTRUMENT THAT TRANSFERS AN INTEREST IN REAL PROPERTY BEFORE IT IS FILED FOR RECORD IN THE PUBLIC RECORDS: YOUR SOCIAL SECURITY NUMBER OR YOUR DRIVER’S LICENSE NUMBER.

STATE OF TEXAS }
 }
COUNTY OF FORT BEND}

KNOW ALL PERSONS BY THESE PRESENTS:

THAT, Lamar Consolidated Independent School District, hereinafter referred to as “Grantor”, whether one or more, for and in consideration of the sum of ONE DOLLAR (\$1.00) CASH to Grantor paid by CenterPoint Energy Houston Electric, LLC, its successors and assigns, hereinafter referred to as “Grantee”, whose principal address is P. O. Box 1700, Houston, Texas 77251-1700, has **GRANTED, SOLD AND CONVEYED** and does by these presents, **GRANT, SELL AND CONVEY** unto said Grantee, all or in part, an exclusive, perpetual aerial easement hereinafter referred to as the “Easement”, for electric transmission and distribution lines and related communication facilities, consisting of a variable number of wires and cables and all necessary and desirable equipment and appurtenances, hereinafter referred to as “Facilities”, located on, over, across, and above a portion of the following described lands owned by Grantor, (“Grantor’s Property”), to wit:

Restricted Reserve “A” in Block 1 of Lamar Consolidated ISD Elementary School No. 24, a subdivision located in the John Foster Survey, Abstract 26, Fort Bend County, Texas, according to the map or plat thereof recorded in Plat No. 20150323 of the Plat Records of said County and State.

The unobstructed easement area(s) herein granted, hereinafter referred to as the “Easement Area”, whether one or more, are described as follows:

An unobstructed aerial easement thirty (30) feet wide, beginning at a plane sixteen (16) feet above the ground and extending upward, the location of the centerline of which is shown by the dot-dash symbol on Sketch No. 16-0830, hereto attached and made a part hereof.

To the extent that such laws and codes apply to Grantor, its successors and assigns, Grantor or its successors and assigns shall observe all safety codes and laws which apply to working along, within and/or near the Easement Area and Facilities during construction activities and safe clearance from such Facilities, including the Occupational Safety and Health Administration ("O.S.H.A."), Chapter 752 of the Texas Health and Safety Code, the National Electric Code, and the National Electrical Safety Code. Grantor, its successors or assigns, is hereby obligated to place National Electrical Safety Code notices into Community Deed Restrictions when the Easement Area falls within residential developments.

Notwithstanding the description of the Easement Area set forth herein, the parties intend that the Easement Area herein granted shall run to the edge of Grantor's Property so that the exteriors of all ground and/or aerial easements herein granted are to intersect with the exteriors of all adjoining easements and/or property lines without creating any gaps between the Easement Area herein granted and any existing easements and/or property lines.

It is expressly stipulated that Grantor, its successors, heirs and assigns, shall not have the right to cause nor permit any structures of whatsoever size, kind and nature, including, but not limited to, antennas or other objects whether temporary or permanent, to be constructed, installed or placed within said Easement Area without the express written consent and approval of Grantee.

The Easement Area herein granted shall be an unobstructed aerial easement with reasonable rights of ingress and egress to and from said Easement Area, together with reasonable working space, for the purposes of erecting, installing, operating, maintaining, replacing, inspecting, and removing said Facilities, together with the additional right to remove from said Easement Area and Grantor's Property immediately adjoining thereto, all bushes, trees and parts thereof, or other structures or improvements which are within, protrude, bisect, encroach or overhang into said Easement Area and which, in the sole opinion of Grantee, endanger or may interfere with the efficient, safe and proper operation, and maintenance of said Facilities.

TO HAVE AND TO HOLD the above described Easement, together with all and singular the rights and appurtenances thereto in anywise belonging, unto Grantee, forever, and Grantor does hereby bind itself and its successors, heirs, assigns, and legal representatives, to fully warrant and forever defend all and singular the above described Easement and rights unto said Grantee, against every person whomsoever lawfully claiming or to claim the same or any part thereof, by, through or under Grantor, but not otherwise. In the event of a deficiency in title or actions taken by others which results in the relocation of Grantee's Facilities, the Grantor herein, its successors and assigns, will be responsible for all costs associated with the relocation and/or removal of Grantee's Facilities.

The terms, conditions and provisions contained herein constitute the complete and final agreement between Grantor and Grantee, (collectively the "Parties") with respect to the subject matter hereof and supersedes all prior agreements, representations and understandings of the Parties and, by Grantor's signature affixed hereto and Grantee's use of the Easement, the Parties evidence their agreement

thereof. No oral or written agreements made or discussed prior to, or subsequent to, the execution of this Easement shall supersede those contained herein. Any and all revisions, amendments and/or exceptions to the terms, conditions and provisions contained in this Easement shall be in written, recordable form and executed by both parties, or their respective successors or assigns in order to be deemed valid.

(Intentionally blank)

EXECUTED this _____ day of _____, 20____.

Lamar Consolidated Independent School District

BY: _____
Signature

Name typed or printed

Title

STATE OF TEXAS }

COUNTY OF _____ }

BEFORE ME, the undersigned authority, a Notary Public in and for the State of Texas, on this day personally appeared _____, _____ of Lamar Consolidated Independent School District, known to me to be the person whose name is subscribed to the foregoing instrument and acknowledged to me that ()he executed the same for the purposes and consideration therein expressed, in the capacity therein stated, and as the act and deed of said school district.

Given under my hand and seal of office this _____ day of _____, 20____.

Notary's Signature

Name typed or printed

Commission Expires

**AFTER RECORDING RETURN TO:
SURVEYING & RIGHT OF WAY
CENTERPOINT ENERGY HOUSTON ELECTRIC, LLC
P. O. BOX 1700
HOUSTON, TX 77251-1700**

JOHN FOSTER SURVEY, A-26

LAMAR CONSOLIDATED ISD
 ELEMENTARY SCHOOL No. 24
 RESTRICTED RESERVE "A"
 PLAT No. 20150323 P.R.
 B L O C K 1



FARM TO MARKET 359
 +/- 5700' TO
 FULSHEAR GASTON RD.

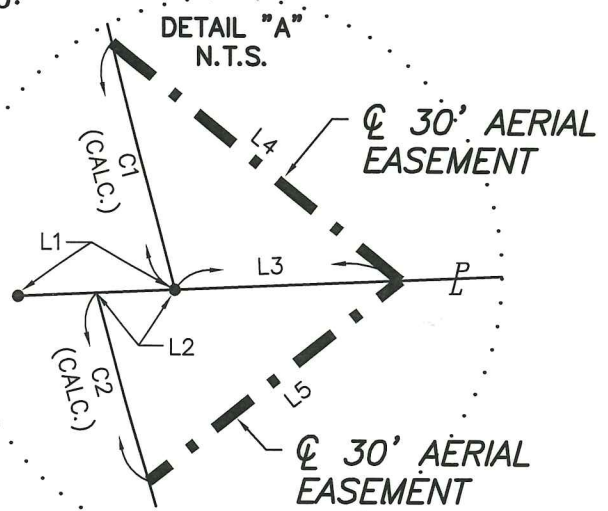

Bearing Basis:
 Texas Coordinate System of:
 1983, South Central Zone
 (TXSC Zone 4204); NAD 83

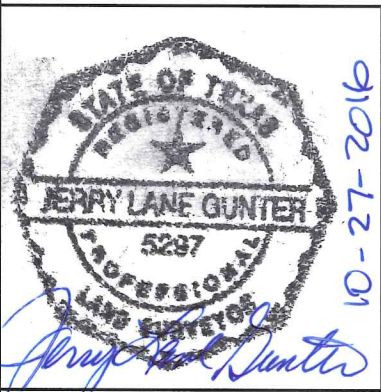

☉ 30' AERIAL EASEMENT
 ☉ 30' AERIAL EASEMENT
 ☉ 30' AERIAL EASEMENT

SEE
 DETAIL "A"
 RESTRICTED
 RESERVE "A"

CREEKSIDE RANCH SEC 2
 PLAT No. 20150089 P.R.
 B L O C K 1

CR HOMEOWNERS ASSOCIATION, INC.
 2016090312 O.P.R.

LOT 36

LEGEND
 ● = FND IR W/cap
 "KALKOMEY SURVEYING"
 UNLESS OTHERWISE NOTED

LOT 37

LOT 35

Line Table

Line #	Length	Direction
L1	20.48'	N 87°30'05" E
L2	10.24'(CALC.)	S 87°30'05" W
L3	29.68'	N 87°30'05" E
L4	48.88'	N 50°50'46" W
L5	42.25'	N 51°30'40" E

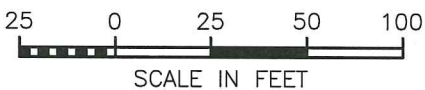

NOTE: THE EXTERIORS OF ALL EASEMENTS ARE TO INTERSECT WITH THE EXTERIORS OF ALL ADJOINING EASEMENTS OR WITH ADJOINING PROPERTY LINES.

Curve Table

Curve #	Length	Radius	Delta	Chord Direction	Chord Length
C1	33.20'	1372.40'	1°23'10"	S 14°23'22" E	33.20'
C2	25.48'	1382.40'	1°03'22"	S 15°31'06" E	25.48'

REV.1: JOB NO.	BY:	DATE:	REV.2: JOB NO.	BY:	DATE:
EASEMENT - UNOBSTRUCTED	LAST PLOT DATE: 10-27-2016		CenterPoint Energy SURVEYING & RIGHT OF WAY P.O. Box 1700 Houston, TX 77251-1700 713-207-2222 Firm Number: 10027400 SKETCH NO. 16-0830		
COUNTY: Fort Bend	DRAWN BY: Gaidosik, A.J.				
SURVEY DATE: 10-17-2016	MAP NO: 4253				
SCALE: 1" = 50'	JOB NO: 79442454A				
FILE NO. - BOOK: B2016	CHECKED BY: J.L.G.	82			

**CONSIDER APPROVAL OF TEXAS EDUCATION AGENCY CODE COMPLIANCE
REVIEW FOR CARTER ELEMENTARY SCHOOL**

RECOMMENDATION:

That the Board of Trustees approve the proposal of American Construction Investigations, Ltd. (ACI) for building code compliance review for Carter Elementary School in the amount of \$16,500 and authorize the Board President to execute the agreement.

IMPACT/RATIONALE:

Code compliance review is a professional service that the District must contract directly. These funds were allocated within the 2014 Bond Budget.

PROGRAM DESCRIPTION:

Code compliance review is required by Texas Education Agency when the local permit jurisdiction does not provide building code reviews. Carter Elementary School is not in an incorporated municipality that performs the code reviews. The review consists of a general review of the plans and specifications for compliance with the 2012 International Building Code.

Submitted By: Kevin McKeever, Administrator for Operations
Steve Hoyt, Vanir/Rice & Gardner Consultants, Inc., A Joint Venture

Recommended for approval:



Dr. Thomas Randle
Superintendent



AMERICAN CONSTRUCTION INVESTIGATIONS, LTD.



602 SAWYER STREET, SUITE 200, HOUSTON, TEXAS 77007-7510
(713) 864-8494 FAX: (713) 864-8495

September 27, 2016

Mr. Kevin McKeever
Administrator of Operations
Lamar CISD
3911 Avenue I
Rosenberg, TX 77471

Re: Building Code Plan Review for Lamar CISD Elementary 26 (Carter ES)

Dear Mr. McKeever:

We are pleased to offer Lamar CISD (Client) this proposal for a Building Code Plan Review of the Lamar CISD Elementary 26 (Carter ES), a new elementary school to be located in Fort Bend County, Texas.

This project consists of an approximately 96,613 gross SF one-story elementary school.

Building Code Review

The Total Plan Review is a general review of the plans and specifications of the proposed new construction with the 2012 International Building Code, 2012 International Fire Code, 2012 Uniform Plumbing Code, 2012 Uniform Mechanical Code, 2014 National Electrical Code and 2009 International Energy Conservation Code. The review will be done in accordance with the requirements of Chapter 61. School Districts - Subchapter CC. Commissioner's Rules Concerning School Facilities -§61.1036. School Facilities Standards for Construction on or after January 1, 2004.

Please provide us:

- One (1) paper set AND one (1) set of pdf files of construction drawings and project manuals
- COMcheck energy analysis report to verify compliance with the IECC or ASHRAE Standard 90.1 energy codes. Note: *If a building shows compliance with Standard 90.1-2007 in one building system (e.g., envelope, lighting, mechanical), then all systems must comply with 90.1-2007. The same rule applies with the IECC—mixing and matching provisions from the two commercial codes does not demonstrate a building's compliance.*

In addition, please provide us with the soils investigation report, structural design calculations, and any other appropriate drawings and/or specifications, sealed and signed by the engineer.

Mr. Kevin McKeever
Lamar CISD Elementary 26 (Carter ES)
September 27, 2016
Page 2

The plan review does not include any detail analysis of any of the buildings of whether or not the buildings are in compliance with any other building code, city ordinance, state or federal laws. Nor does this proposal include any inspections.

General Conditions

1. ACI will submit its review in a written report. Two copies of the report will be submitted.
2. ACI shall rely on the information furnished by the Client. The proposal is based upon having above all of the items noted above available for review.
3. Our proposal does not include any design solutions, cost estimates or drawings.
4. It is mutually agreed, in undertaking these proposed services, that ACI is assuming none of the responsibilities of the Architect-of-Record, nor is ACI assuming as a sub-contractor or otherwise on behalf of the Client, any of the responsibilities that the Client has undertaken through its contract with its client. The Client agrees that the limit of liability of ACI for any claim against it for services provided under this agreement shall be the sum of its fees pursuant to this agreement.

We propose to provide the above listed consulting services for a total fee of \$16,500.00

We expect the initial plan review to be completed in 2 weeks after receipt of all items requested and a notice to proceed. A follow-up review will be provided after the deficiencies are corrected on the contract documents. This proposal includes one follow-up revision. If this proposal meets with your approval, please indicate your acceptance by signing below.

Thank you for this opportunity. We look forward to working with you.

Sincerely yours,

AMERICAN CONSTRUCTION INVESTIGATIONS, LTD.



Henry R. Hermis, Jr., AIA
ICC Certified Building Plans Examiner
#1017734-B3

APPROVED AND ACCEPTED

DATE

**CONSIDER APPROVAL OF TRAFFIC STUDY
FOR CARTER ELEMENTARY SCHOOL**

RECOMMENDATION:

That the Board of Trustees approve Traffic Engineers, Inc. for the traffic study at Carter Elementary School in the amount of \$20,000 and authorize the Board President to execute the agreement.

IMPACT/RATIONALE:

The traffic engineering study is a professional service that the District must contract directly. These funds were allocated within the 2014 Bond Budget.

PROGRAM DESCRIPTION:

The traffic engineering study will generate reports that provide traffic flow patterns the architect needs to complete the construction specifications. These reports are crucial in the design and construction of Carter Elementary School.

Submitted By: Kevin McKeever, Administrator for Operations
Steve Hoyt, Vanir/Rice & Gardner Consultants, Inc., A Joint Venture

Recommended for approval:

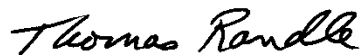

Dr. Thomas Randle
Superintendent

TRAFFIC ENGINEERS, INC.

INNOVATIVE TRANSPORTATION SOLUTIONS

801 Congress
Suite 325
Houston, TX 77002

Voice (713) 270-8145
Fax (281) 809-0807
www.trafficengineers.com

Texas Registration Number F-003158

December 6, 2016

Mr. Kevin McKeever
Administrator of Operations
Lamar Consolidated ISD
3911 Ave I
Rosenberg, Texas 77471

Re: Proposal for Traffic Study for LCISD Carter Elementary School

Dear Mr. McKeever:

This letter constitutes our proposal to conduct a Traffic Study for the proposed LCISD Carter Elementary School. The site is south of A. Meyers Road and west of Berdett Road (future Grand Parkway) in the City of Rosenberg ETJ. The following scope reflects comments received from City of Rosenberg and Fort Bend County staff in a meeting on December 2, 2016.

Scope of Services

Task 1 - Data Collection

Traffic Engineers, Inc. will conduct School AM and PM peak hour Turning Movement Counts (6:30-8:30 AM and 1:45-3:45 PM) at the following locations:

- A. Meyers Road at Berdett Road (future Grand Parkway)
- A. Meyers Road at Laurabee Drive

The following information has been provided by Rice & Gardner Consultants Incorporated (Rice & Gardner):

- Year school will open
- Arrival and dismissal times
- Number of students
- Number of staff
- Number of buses (regular routes and special needs)
- Number of day care vans
- Names of existing schools that generate approximately the same amount of parent traffic expected to be generated by the future Carter Elementary School (Thomas and Williams Elementary)
- Approximate attendance zone (southeast portion of LCISD)

Additional information to be provided by Rice & Gardner includes confirmation that six portable buildings could potentially be located on-site and the ultimate capacity of the school will be 1,050 students based on the installation of six portable buildings.

A site visit will be conducted to collect pertinent information for the study. Traffic Engineers, Inc. will observe dismissal at Thomas and Williams Elementary Schools, which LCISD estimates

generate approximately the same amount of parent traffic expected to be generated at the Carter Elementary. The total number of parents and the maximum queue of parents will be used to determine the amount of on-site stacking needed at Carter Elementary.

Task 2 - Trip Generation and Distribution

The amount of traffic expected to be generated by Carter Elementary School at Ultimate Enrollment (including potential portable buildings) will be estimated based on the information obtained from Rice & Gardner in Task 1 and data collected at the existing schools.

The traffic volumes will be distributed to the following intersections:

- A. Meyers Road at Berdett Road (future Grand Parkway)
- A. Meyers Road at Laurabee Drive
- A. Meyers Road at Student Drop-off/Pick-up Exit Driveway (will operate as an exit only driveway during arrival and dismissal)
- Laurabee Drive at Bus/Staff Driveway
- Laurabee Drive at Student Drop-off/Pick-up Entrance Driveway

The school traffic will be distributed to the intersections above based on two scenarios:

- Construction of the Laurabee Drive bridge across Dry Creek
- Construction of Laurabee Drive to the southern school site boundary (north of Dry Creek)

Task 3 - Traffic Impact Analysis

The school site plan will be evaluated with respect to on-site traffic circulation. The amount of on-site storage needed for the student drop-off/pick-up area, the bus loading/unloading area and staff parking lot will be analyzed for Ultimate Enrollment, which includes all potential portable buildings, and both Laurabee Drive construction scenarios identified in Task 2.

Traffic projections will be developed at the following intersections for both Laurabee Drive construction scenarios:

- A. Meyers Road at Berdett Road (future Grand Parkway)
- A. Meyers Road at Laurabee Drive
- A. Meyers Road at Student Drop-off/Pick-up Exit Driveway (will operate as an exit only driveway during arrival and dismissal)
- Laurabee Drive at Bus/Staff Driveway
- Laurabee Drive at Student Drop-off/Pick-up Entrance Driveway

The traffic projections will include an increase in through traffic volumes on A. Meyers Road due to the development of future Bonbrook Plantation and other residential development west of the school site, as well as traffic generated for the opening year of the elementary school assuming Ultimate Enrollment with portable buildings.

The impact of the school generated traffic on the adjacent roadways will be analyzed for both Laurabee Drive construction scenarios to ensure adequate off-site circulation and acceptable traffic operations at the intersections identified above in Task 3.

Off-site improvements such as left-turn lanes and the turn lane storage length will be recommended, where needed. Pedestrian improvements such as sidewalks, crosswalks, crossing

guards and School Speed Zones will also be recommended. The improvements could differ for the two Laurabee Drive construction scenarios.

Task 4 - Study Findings

A report will be prepared documenting the findings and recommendations for on-site and off-site circulation based on the analyses of two Laurabee Drive construction scenarios: 1) construction of the Laurabee Drive bridge across Dry Creek and 2) construction of Laurabee Drive to the southern school site boundary (north of Dry Creek).

The study will be submitted to the City of Rosenberg and Fort Bend County for review and approval.

Compensation and Schedule

Based on our estimate of hours required to complete this project, compensation of \$20,000 is proposed on a lump sum basis.

A draft report will be submitted to LCISD/Rice & Gardner for review.

Please contact me at (713) 992-4792 or at jessica@trafficengineers.com if you have any questions regarding this proposal.

Sincerely,



Jessica Jia, PE
Senior Associate

**CONSIDER APPROVAL OF MATERIALS TESTING
FOR TERRY HIGH SCHOOL BASEBALL COMPLEX RENOVATIONS**

RECOMMENDATION:

That the Board of Trustees approve Terracon, Inc. for materials testing for the Terry High School baseball complex renovations in the amount of \$34,532 and authorize the Board President to execute the agreement.

IMPACT/RATIONALE:

Materials testing is a professional service that the District must contract directly. These funds were allocated within the 2014 Bond Budget.

PROGRAM DESCRIPTION:

Materials testing services will generate reports and verify that materials are installed correctly as per specifications. These reports are crucial in verifying the quality of the construction of the Terry High School Baseball Complex renovations.

Submitted By: Kevin McKeever, Administrator for Operations
Steve Hoyt, Vanir/Rice & Gardner Consultants, Inc., A Joint Venture

Recommended for approval:



Dr. Thomas Randle
Superintendent

December 6, 2016

Lamar Consolidated Independent School District
Attn: Mr. Kevin McKeever
3911 Avenue I
Rosenberg, Texas 77471

Subject: Proposal for Construction Materials Testing Services
B.F. Terry High School Baseball and Softball Improvements
5500 Avenue N
Rosenberg, Texas 77471
Terracon Proposal No. P92161538

Dear Mr. McKeever:

Terracon Consultants, Inc. (Terracon) is pleased to submit this proposal to provide construction materials engineering and testing services for the above referenced project. It is our understanding that we have been selected solely based our professional qualifications. In this proposal we present our understanding of the scope of the project, our proposed services, and our budget estimate.

Terracon provided geotechnical services for this project. Our presence on this project and commitment to responsive quality services will make Terracon a valuable asset to the project.

A) PROJECT INFORMATION

The site is located at 5500 Avenue N in Rosenberg, Texas. The project involves the construction of new baseball and softball field dugouts, new backstops, a new press box and new concession stand. The building foundation will consist of shallow spread footings. The slabs at grade will be supported on 36 inches of select fill. The superstructure will consist of structural masonry walls and structural steel framing.

If blended or mixed soils are intended for use to construct the pad and slab areas, Terracon should be contacted to provide additional recommendations. Blended or mixed soils do not occur naturally. These soils are a blend of sand and clay and will require mechanical mixing with a pulver-mixer at the site. If these soils are not mixed thoroughly to break down the clay clods and blend-in the sand to produce a uniform soil matrix, the fill material may be detrimental to the slab performance. If blended soils are used, we recommend that additional samples of the blended soils, as well as the clay clods, be obtained prior to and during earthwork operations to evaluate if the blended soils can be used in lieu of select fill. The actual type and amount of mechanical mixing at the site will depend on the amount of clay and sand, and properties of the clay.



Proposal for Construction Materials Testing Services

Terry H.S. Baseball and Softball Improvements ■ 5500 Avenue N

December 6, 2016 ■ Terracon Proposal No. P92161538



Terracon was provided with the following construction documents for preparation of this proposal:

- Structural plans prepared by AG&E Structural Engenuity, dated November 11, 2016
- Civil plans prepared by PBK Sports, dated November 11, 2016
- Project specifications prepared by PBK Sports, dated November 11, 2016
- Terracon Geotechnical Engineering Report No. 92165314, dated July 15, 2016

If selected for this project, Terracon requests that we be placed on the distribution of all plan revisions.

B) SCOPE OF SERVICES

Terracon prepared the following scope of services based on our review and understanding of the documents listed above:

Earthwork:

1. Sample building pad subgrade, building pad select fill, trench backfill and treated pavement subgrade materials. Prepare and test the samples for Atterberg Limits (ASTM D4318), moisture-density relationship (ASTM D698 and ASTM D558).
2. It is Terracon's experience that "blended" select fill soils are commonly used in the greater Houston area. Therefore, Terracon recommends that one sample of soil be obtained for every 250 cubic yards of select fill during construction of the building pad, a minimum of one sample per day, to verify that the soil meets the requirements for Atterberg Limits (ASTM D4318) and if required by the project specifications, percent fines (ASTM D1140). **Samples typically require 2 to 3 working days for processing and testing in accordance with ASTM Standards. However, preliminary test results may be available as early as the following working day. It will be at the discretion of the contractor to suspend any additional placement of fill before Atterberg Limits test results are known. It should be noted that achieving compaction of placed soils prior to verification that placed soils meet select fill criteria does not constitute acceptance of the fill material.**
3. Sample cement-sand backfill for utility trenches, mold specimens, and perform compressive strength tests in the laboratory (ASTM D1633).
4. Evaluate the subgrade soil for proposed chemically treated pavement subgrade.
5. Observe the chemical treatment process for the pavement subgrade.
6. Perform field gradation tests of treated subgrade.

Proposal for Construction Materials Testing Services

Terry H.S. Baseball and Softball Improvements ■ 5500 Avenue N

December 6, 2016 ■ Terracon Proposal No. P92161538



7. Measure the depth of treated subgrade using phenolphthalein.
8. Observe proofrolling operations of the building pad and pavement subgrades; and perform density tests of the building subgrade, building pad select fill, treated pavement subgrade, and trench backfill (when proper trench safety is provided by the contractor) using the nuclear method (ASTM D6938) to determine the moisture content and percent compaction of the soil materials.

Foundations:

1. For shallow footings, obtain pocket penetrometer readings on soil cuttings removed during excavation at or near the bearing stratum in order to document the approximate shear strength of the soil.
2. Observe the shallow footing excavations. Record dimensions and the number, size and length of reinforcing bars used in footings.
3. The reinforcing steel and anchor bolts used in footing columns will be observed and the quantity and size of the steel will be recorded.
4. Perform compressive tests of concrete test cylinders cast in the field (ASTM C1231 or C617, C39).

Cast-in-Place Concrete:

1. Sample and test the fresh concrete for each mix. Perform tests for slump, air content, and concrete temperature only; and cast test specimens (ASTM C172, C31, C143, C173 or C231, and C1064). Terracon understands that the contractor will be responsible for maintaining the initial curing temperature of the concrete test specimens. Terracon will record the initial curing temperatures only when conditioned curing boxes are provided by the contractor.
2. Concrete will be sampled at a frequency of 1 set of test cylinders every 50 cubic yards for structural concrete, 1 set of test cylinders every 100 cubic yards for slabs, and 1 set of test cylinders every 150 cubic yards for pavement concrete. Terracon requests that a copy of the approved mix design(s) be provided to us prior to placement of the concrete.
3. Perform compressive strength tests of concrete test cylinders cast in the field (ASTM C1231, C39). Five 4" x 8" concrete cylinders will be prepared for structural concrete having nominal size aggregate of 1¼" or less. Four 6" x 12" concrete cylinders per set will be prepared for concrete having a nominal size aggregate of greater than 1¼".

Proposal for Construction Materials Testing Services

Terry H.S. Baseball and Softball Improvements ■ 5500 Avenue N

December 6, 2016 ■ Terracon Proposal No. P92161538



When 6" x 12" cylinders are prepared, two cylinders will be tested at 7 and 28 days. When 4" x 8" cylinders are prepared, two cylinders will be tested at 7 days and three cylinders will be tested at 28 days.

4. Observe reinforcing steel prior to concrete placement. We will observe the rebar size, spacing and configuration. **Terracon recommends we be scheduled a minimum of 24 hours prior to each concrete placement.**

Masonry:

1. Observe and document the condition of storage areas for masonry materials.
2. Observe and document the mixing proportions of mortar and grout used during construction.
3. Observe the reinforcing steel in CMU walls and bond beams.
4. Sample fresh mortar materials from the project site and prepare lab molded mortar cubes for compressive strength tests (ASTM C270 and C109).
5. Sample the fresh grout during construction and cast grout prisms (ASTM C1019) for compressive strength tests.
6. Sample CMU block and test for absorption and compressive strength (ASTM C140).
7. Observe fabrication of CMU prisms, transport CMU prisms to our laboratory after initial curing, and test for compressive strength.

Structural Steel Welded and Bolted Connections:

1. Terracon recommends that the general contractor schedule a pre-erection meeting to discuss the erection sequence, review welding and bolting requirements and to review welder certification records.
2. Provide a Certified Welding Inspector (CWI) in the field to visually check accessible field bolted/welded connections in accordance with applicable AISC and AWS specifications.
3. Perform visual inspections of metal decking for placement including overlap, fastener spacing, shear studs for number, pattern, and bond, supports at openings and penetrations, and puddle welds pattern, size and quality.

Project Management/ Administration:

A project manager will be assigned to the project to review the daily activity and assist in scheduling the work. Field and laboratory tests will be reviewed prior to submittal. The project manager will be responsible for maintaining the project budget and will oversee the preparation of the final test reports.

Terracon recommends that the general contractor schedule pre-construction meetings prior to each phase of our proposed testing and observations to discuss the erection sequence, review welding and bolting requirements and to review welder certification records.

Special Inspections Letter:

Upon completion of our services, a special inspection letter will be prepared, if requested. The letter will list services we performed and if the results and/ or observations were in compliance with the project documents. A copy of our test reports will be available with the special inspection letter if requested.

Scheduling Retests:

It is the responsibility of your representative to schedule retests in a like manner to scheduling our original services. Terracon shall not be held responsible for retests not performed as a result of a failure to schedule our services or any subsequent damage caused as a result of a lack of retesting.

Additional Services:

If you would like us to perform additional work, please contact us and we will issue a short Supplement to Agreement form, or Supplemental Proposal, that outlines the additional work to be performed and associated fees. To authorize us to begin work, you simply return a signed copy of the Supplemental agreement.

Mechanically Stabilized Earth (MSE) Walls:

This proposal excludes materials testing and observations related to mechanically stabilized earth (MSE) walls. Should the owner or client require Terracon to provide services on any portion of the MSE wall, Terracon should be requested to provide a separate proposal prior to start of construction of the MSE walls. Terracon requires an internal cursory review of the MSE wall design. This cursory review is only for internal Terracon purposes and is intended to establish the appropriate scope of construction materials testing services for the project if it is decided we will accept the assignment. This

Proposal for Construction Materials Testing Services

Terry H.S. Baseball and Softball Improvements ■ 5500 Avenue N

December 6, 2016 ■ Terracon Proposal No. P92161538



review should not be construed as accepting any design responsibility or providing any review capacity for the contractor or owner.

C) REPORTING

Results of field tests will be submitted verbally to available personnel at the site. Written reports of field tests and observations will be distributed within five business days. Test reports will be distributed via e-mail. You will need to provide Terracon with a distribution list prior to the beginning of the project. The list will need to include the company name, address, contact person name, phone number, and e-mail address for each person.

Our reported test locations will typically be estimated by pacing distances and approximating angles and elevations from local control data (staking and layout lines) provided by others on site. The accuracy of our locations will be dependent on the accuracy, availability and frequency of the control points provided by the client and/ or contractor.

PROJECT STAFFING AND ADMINISTRATION

Field testing services will be provided on an "as requested" basis when scheduled by your representative. A notice of 24 hours (48 hours is required for structural steel services) is required to properly schedule our services. To schedule our services please contact our dispatcher at (713) 690-2258. The dispatch office hours are from 7:00 a.m. to 5:00 p.m. Messages left after business hours will be checked the following business day. Terracon shall not be held responsible for tests not performed as a result of a failure to schedule our services or any subsequent damage caused as a result of a lack of testing.

Terracon recommends that a copy of this proposal be provided to the general contractor so they understand our scope of services and schedule us accordingly. Please note that the number of tests and trips described in the Scope of Services does not constitute a minimum or maximum number of tests or trips that may be required for this project.

D) COMPENSATION

Based on the project information available for our review, we propose an estimate cost of **\$34,532**. Services provided will be based on the unit rates included in the attached Cost Estimate. Please note that this is only a budget estimate and not a not-to-exceed price. Many factors beyond our control, such as weather and the contractor's schedule, will dictate the final fee for our services. Quantities for re-tests, cancellations and stand-by time are not included in our fee.

For services provided on an "as requested" basis, overtime is defined as all hours in excess of eight hours per day, outside of the normal hours of 7:00 a.m. to 6:00 p.m. Monday through Friday, and all hours worked on weekends and holidays. Overtime rates will be 1.5 times the hourly rate

Proposal for Construction Materials Testing Services

Terry H.S. Baseball and Softball Improvements ■ 5500 Avenue N

December 6, 2016 ■ Terracon Proposal No. P92161538



quoted. A four hour minimum charge is applicable to all trips made to provide our testing, observation and consulting services. The minimum charge is not applicable for trips to the project site for sample pickup only. All labor, equipment and transportation charges are billed on a portal to portal basis from our office. You will be invoiced on a monthly basis for services actually performed and/or as authorized by you or your designated representative. Terracon's total invoice fee is due within thirty days following final receipt of invoice.

E) SITE ACCESS AND SAFETY

Client shall secure all necessary site related approvals, permits, licenses, and consents necessary to commence and complete the services and will execute any necessary site access agreement. Terracon will be responsible for supervision and site safety measures for its own employees, but shall not be responsible for the supervision or health and safety precautions for any third parties, including Client's contractors, subcontractors, or other parties present at the site.

F) TESTING AND OBSERVATION

Client understands that testing and observation are discrete sampling procedures, and that such procedures indicate conditions only at the depths, locations, and times the procedures were performed. Terracon will provide test results and opinions based on tests and field observations only for the work tested. Client understands that testing and observation are not continuous or exhaustive, and are conducted to reduce – not eliminate - project risk. Client agrees to the level or amount of testing performed and the associated risk. Client is responsible (even if delegated to contractor) for notifying and scheduling Terracon so Terracon can perform these services. Terracon shall not be responsible for the quality and completeness of Client's contractor's work or their adherence to the project documents, and Terracon's performance of testing and observation services shall not relieve contractor in any way from its responsibility for defects discovered in its work, or create a warranty or guarantee. Terracon will not supervise or direct the work performed by contractor or its subcontractors and is not responsible for their means and methods.

G) AUTHORIZATION

This proposal may be accepted by executing the attached Supplement To Agreement For Services and returning an executed copy along with this proposal to Terracon. This proposal for services and accompanying limitations shall constitute the exclusive terms, conditions and services to be performed for this project. This proposal is valid only if authorized within sixty days from the listed proposal date. **Terracon cannot begin field and laboratory services without a signed Agreement for Services.**

Proposal for Construction Materials Testing Services

Terry H.S. Baseball and Softball Improvements ■ 5500 Avenue N

December 6, 2016 ■ Terracon Proposal No. P92161538



We appreciate this opportunity of working with you and we look forward to working with you in the future.

Sincerely,

Terracon Consultants, Inc.

(TBPE Firm Registration No. F-3272)

A blue ink signature of Chad C. Gordon.

Chad C. Gordon, P.E.

Assistant Materials Services Manager

A blue ink signature of Alfonzo Hernandez.

Alfonzo Hernandez, P.E.

Materials Services Manager

Attachments:

- (1) Cost Estimate
- (2) Supplement To Agreement For Services



COST ESTIMATE

B.F. Terry High School Baseball / Softball Improvements
5500 Avenue N - Rosenberg, Texas 77471
Terracon Proposal P92161538

Service (As described in proposal)	Quantity	Unit	Unit Rate	Estimate
EARTHWORK				
Estimate 5 trips at 8 hours each to test compaction of backfill for on-site utilities				
Estimate 3 trips at 4 hours to obtain select fill and subgrade samples				
Estimate 1 trip at 6 hours each to observe application of subgrade treatment				
Estimate 1 trip at 6 hours each to check treatment depth and gradation				
Estimate 4 days at 12 hours each to test compaction of subgrade and select fill placement				
Field Representative, Regular Hours	96	hours	\$ 46.00	\$ 4,416.00
Field Representative, Over Time Hours	16	hours	\$ 69.00	\$ 1,104.00
Nuclear Density Gauge	9	trip	\$ 60.00	\$ 540.00
Lime Determination	1	each	\$ 300.00	\$ 300.00
Moisture Density Relationship	4	each	\$ 165.00	\$ 660.00
Atterberg Limits	3	each	\$ 65.00	\$ 195.00
Soil Verification Atterberg Limits	4	each	\$ 65.00	\$ 260.00
Cement Stabilized Sand	4	each	\$ 60.00	\$ 240.00
Vehicle Charge	14	trip	\$ 60.00	\$ 840.00
Subtotal, Earthwork				\$ 8,555.00
FOUNDATIONS				
Estimate 6 trips at 10 hours each to observe shallow footings and test concrete				
Estimate 4 trips at 8 hours to observe reinforcing steel and test concrete for grade beams				
Estimate 8 trips at 2 hours each to pick up sample and return to laboratory				
Senior Field Representative, Regular Hours	96	hours	\$ 46.00	\$ 4,416.00
Senior Field Representative, Over Time Hours	12	hours	\$ 69.00	\$ 828.00
Concrete Compressive Strength	48	each	\$ 16.00	\$ 768.00
Vehicle Charge	18	each	\$ 60.00	\$ 1,080.00
Subtotal, Foundations				\$ 7,092.00
CAST-IN-PLACE CONCRETE				
Estimate 5 trips at 4 hours each to observe reinforcing steel for slabs-on-grade and pavements				
Estimate 5 trips at 2 hours each to pick up sample and return to laboratory				
Field Representative, Regular Hours	32	hours	\$ 46.00	\$ 1,472.00
Field Representative, Over Time Hours	6	hours	\$ 69.00	\$ 414.00
Concrete Compressive Strength	25	each	\$ 16.00	\$ 400.00
Vehicle Charge	10	each	\$ 60.00	\$ 600.00
Subtotal, Cast-in-Place Concrete				\$ 2,886.00
STRUCTURAL STEEL				
Estimate 5 trips at 6 hours each to observe steel framing and connections in the field				
Certified Welding Inspector, Regular Hours	30	hours	\$ 90.00	\$ 2,700.00
Vehicle Charge	5	each	\$ 60.00	\$ 300.00
Subtotal, Structural Steel				\$ 3,000.00



COST ESTIMATE

B.F. Terry High School Baseball / Softball Improvements
5500 Avenue N - Rosenberg, Texas 77471
Terracon Proposal P92161538

Service (As described in proposal)	Quantity	Unit	Unit Rate	Estimate
MASONRY				
Estimate 10 trips at 8 hours each to observe masonry and test mortar and grout				
Estimate 1 trip at 4 hours each to sample CMU block				
Estimate 10 trips at 2 hours each to pick up sample and return to laboratory				
Field Representative, Regular Hours	104	hours	\$ 46.00	\$ 4,784.00
Sample Mortar Materials and Cast Lab Molded Compressive Strength Cubes (set of 6)	1	each	\$ 500.00	\$ 500.00
Grout Compressive Strength (sets of 6)	36	each	\$ 35.00	\$ 1,260.00
Concrete Masonry Unit Strength and Absorption	6	each	\$ 100.00	\$ 600.00
CMU Prism Compressive Strength	3	each	\$ 200.00	\$ 600.00
Vehicle Charge	21	each	\$ 60.00	\$ 1,260.00
Subtotal, Masonry				\$ 9,004.00
PROJECT MANAGEMENT				
Project Manager & Administration	31	hours	\$ 125.00	\$ 3,875.00
Vehicle Charge	2	each	\$ 60.00	\$ 120.00
Subtotal, Project Management & Administration				\$ 3,995.00
ESTIMATED COST				\$ 34,532.00

SUPPLEMENT TO AGREEMENT FOR SERVICES

CHANGE TO SCOPE OF SERVICES AND FEES

This **SUPPLEMENT to AGREEMENT FOR SERVICES** to the original Agreement for Services (original Agreement dated 05/25/2016, Agreement reference number P92165314.Revision1) is between Lamar Consolidated ISD ("Client") and Terracon Consultants, Inc. ("Consultant") for additional or changed Services to be provided by Consultant for client on the Project, as described in the Agreement for Services. This Supplement is incorporated into and part of the Agreement for Services.

- 1. Scope of Services.** The scope of the additional or changed Services are described in the Scope of Services section of the Consultant's Supplemental Proposal, unless Services are otherwise described below or in Exhibit B to this Supplement (which section or exhibit are incorporated into the Supplement).

Refer to Terracon Proposal No. P92161538 dated December 6, 2016

- 2. Compensation.** Client shall pay compensation for the additional or changed Services performed at the fees stated in the Supplemental Proposal unless fees are otherwise stated below or in Exhibit C to this Supplement (which section or exhibit are incorporated into the Supplement).

Refer to Terracon Proposal No. P92161538 dated December 6, 2016

All terms and conditions of the **Agreement for Services** shall continue in full force and effect. This Supplement is accepted and Consultant is authorized to proceed.

Consultant: **Terracon Consultants, Inc.**
By:  Date: **12/6/2016**
Name/Title: **Chad Gordon, P.E. / Senior Project Manager**
Address: **11555 Clay Rd Ste 100**
Houston, TX 77043-1239
Phone: **(713) 690-8989** Fax: **(713) 690-8787**
Email: **Chad.Gordon@terracon.com**

Client: **Lamar Consolidated ISD**
By: _____ Date: _____
Name/Title: **James Steenberg**
Lamar CISD Board President
Address: **3911 Avenue I**
Rosenberg, TX 77471
Phone: **(281) 341-3122** Fax: **(281) 341-3129**
Email: **mckeever@lcisd.org**

CONSIDER APPROVAL OF DONATION DEED

RECOMMENDATION:

That the Board of Trustees approve the donation deed of 0.2511 acres to Fort Bend County for the deceleration lane on FM 1093 and authorize the Board President to execute the deed and related documents.

IMPACT/RATIONALE:

Fort Bend County is expanding the original request of 0.1088 acres, approved by the Board of Trustees in November, to 0.2511 to provide the turn lane along the entire southern border of the site. This donation deed is needed for the turn lane entering the Fulshear High school site at Bois D' Arc Road and the center driveway to the east of Bois D' Arc.

PROGRAM DESCRIPTION:

Upon approval, Fort Bend County can continue the engineering and construction of the West Park Toll road and the expansion of FM 1093.

Submitted by: Kevin McKeever, Administrator for Operations
Ed Bailey, Gilbane

Recommended for approval:



Dr. Thomas Randle
Superintendent

every person whomsoever lawfully claiming or to claim the same or any part thereof, subject only to the Permitted Encumbrances.

If current ad valorem taxes on said Property have not been prorated at the time of closing, Grantor and Grantee shall be responsible for payment of its respective share thereof based on period of ownership.

Grantee's address is 301 Jackson Street, Richmond, Texas 77469.

EXECUTED on this the _____ day of _____, 2016.

GRANTOR:

Lamar Consolidated Independent School District

By: _____

Name, Title

THE STATE OF TEXAS §
 §
COUNTY OF FORT BEND §

This instrument was acknowledged before me on the ____ day of _____, 2016 by _____, _____, on behalf of Lamar Consolidated Independent School District.

(SEAL)

Notary Public in and for the State of Texas

AGREED to and ACCEPTED on this the _____ day of _____, 2016.

GRANTEE:

FORT BEND COUNTY, TEXAS, a body corporate and politic under the laws of the State of Texas.

By: _____

Robert E. Hebert, County Judge

THE STATE OF TEXAS §
 §
COUNTY OF FORT BEND §

This instrument was acknowledged before me on the _____ day of _____, 2016 by Robert E. Hebert, County Judge of Fort Bend County, Texas, a body corporate and politic under the laws of the State of Texas, on behalf of said body corporate and politic.

(SEAL)

Notary Public in and for the State of Texas

Attachments:
Exhibit A – Legal Description of the Property

After Recording Return to:
Fort Bend County Engineering
Attn: Bryan Norton
301 Jackson Street
Richmond, Texas 77469

EXHIBIT A

EXHIBIT A

County: Fort Bend
Highway: F.M. 1093
Project Limits: James Lane to FM 1463 / FM 359
RCSJ: 0543-02-072

Property Description for Parcel 408

Being a 0.2511 acre (10,939 square feet) parcel of land, out of the E. Latham Survey A-50, Fort Bend County, Texas, and being part of and out of that certain called 124.49 acre tract of land, described in a Deed dated December 15, 2008 from Teri Straus, Shelley Jucker, Cynthia Lynn Klein, Sylvia Gandler Solomon, Trustee and Suzanne Stein to Lamar Consolidated Independent School District filed in the Official Public Records of Fort Bend County, Texas (O.P.R.F.B.C.) at Clerk's File No. 2008129534, said 124.49 acre tract, also being out of Restricted Reserve "C", Lamar Consolidated Independent School District High School No. 5 Complex recorded under Clerk's File No. 20110054 of the Plat Records of Fort Bend County, Texas (F.B.C.P.R.), Fort Bend County, Texas, said 0.2511 acre parcel being more particularly described as follows:

COMMENCING at a 5/8-inch iron rod found for an interior corner of Restricted Reserve "A" of said Lamar Consolidated Independent School District High School No. 5 Complex and for the northwest corner of a called 1.9206 acre tract of land, described in a Deed dated July 20, 2009 from George Edward Hackett and wife Alline Hackett to MGJ Holdings, L.P. filed in the O.P.R.F.B.C. at Clerk's File No. 2009077986, said 1.9206 acre tract, also being out of Commercial Reserve "A" and Commercial Reserve "B", Lazy J Acres, Section 1, Replat No. 1 recorded under Clerk's File No. 20130137 of the F.B.C.P.R.; thence as follows:

South 02°45'41" East, a distance of 390.78 feet, along an interior line of said Restricted Reserve "A" and along the west line of said 1.9206 acre tract, to a 5/8-inch iron rod with TxDOT aluminum cap set in the proposed north right-of-way line of said FM 1093 (width varies), for the northeast corner and POINT OF BEGINNING of the herein described parcel, said point having Coordinates of N=13,814,002.60 and E=2,957,874.16;**

- 1) THENCE, South 02°45'41" East, a distance of 10.03 feet, , along an interior line of said Restricted Reserve "A" and along the west line of said 1.9206 acre tract, to a point in the existing north right-of-way line of said F.M. 1093 (120' wide) as described in Volume 243, Page 171 of the F.B.C.D.R. and for the southeast corner of the herein described parcel;

EXHIBIT A

- 2) THENCE, South $82^{\circ}58'36''$ West, a distance of 562.48 feet, along the south line of said 124.49 acre tract and along the existing north right-of-way line of said F.M. 1093, to an angle point of the herein described parcel;
- 3) THENCE, South $83^{\circ}00'31''$ West, a distance of 499.65 feet, along the south line of said 124.49 acre tract and along the existing north right-of-way line of said F.M. 1093 to the existing east right-of-way line of Bois D Arc Lane (Width Varies) as described in Clerk's File No. 20110054 of the F.B.C.P.R., to a point for the southwest corner of the herein described parcel;
- 4) THENCE, North $00^{\circ}32'37''$ West, a distance of 35.43 feet, along the existing east right-of-way line of said Bois D Arc Lane, to a 5/8-inch iron rod with TxDOT aluminum cap set for the northwest corner of the herein described parcel;**
- 5) THENCE, South $48^{\circ}46'03''$ East, a distance of 33.80 feet, along the proposed north right-of-way line of said F.M. 1093, to a 5/8-inch iron rod with TxDOT aluminum cap set for an angle point of the herein described parcel;**
- 6) THENCE, North $83^{\circ}00'31''$ East, a distance of 473.15 feet, along the proposed north right-of-way line of said F.M. 1093, to a 5/8-inch iron rod with TxDOT aluminum cap set for an angle point of the herein described parcel;
- 7) THENCE, North $82^{\circ}58'36''$ East, a distance of 563.22 feet, along the proposed north right-of-way line of said F.M. 1093, to the POINT OF BEGINNING and containing 0.2511 acre (10,939 square feet) parcel of land.

NOTE: All bearings are based on the Texas coordinate system, NAD 83 (1993 Adj.), South Central Zone. All coordinates shown are surface and may be converted to grid by Dividing by TxDOT conversion factor of 1.00013.

All coordinates shown hereon are established from TxDOT Control Monuments, H-3, H-4, H-5, and H-13 prepared by Costello, Inc. dated February 23, 2000 and TxDOT Control Monuments H-5A and H-5B prepared by Weisser Engineering Company dated October 2006.

** The monument described and set in this call may be replaced with a TxDOT Type II Right of Way marker upon completion of the highway construction project under the supervision of a Registered Professional Land Surveyor, either employed or retained by TxDOT.

Access will be permitted to the remainder property abutting the highway facility.

EXHIBIT A

NOTE: A parcel plat of even date was prepared in conjunction with this property description.

Compiled by:
Weisser Engineering Company
TBPLS Firm Reg. No. 100518-00
19500 Park Row, Suite 100
Houston, Texas 77084
(281) 579-7300
July, 2015
Revised: November, 2016

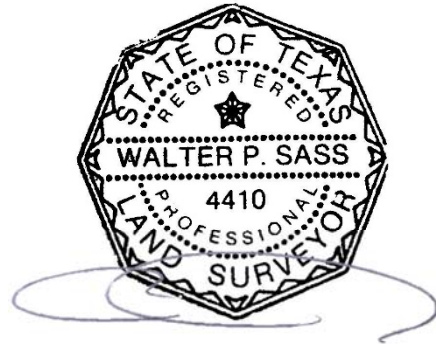

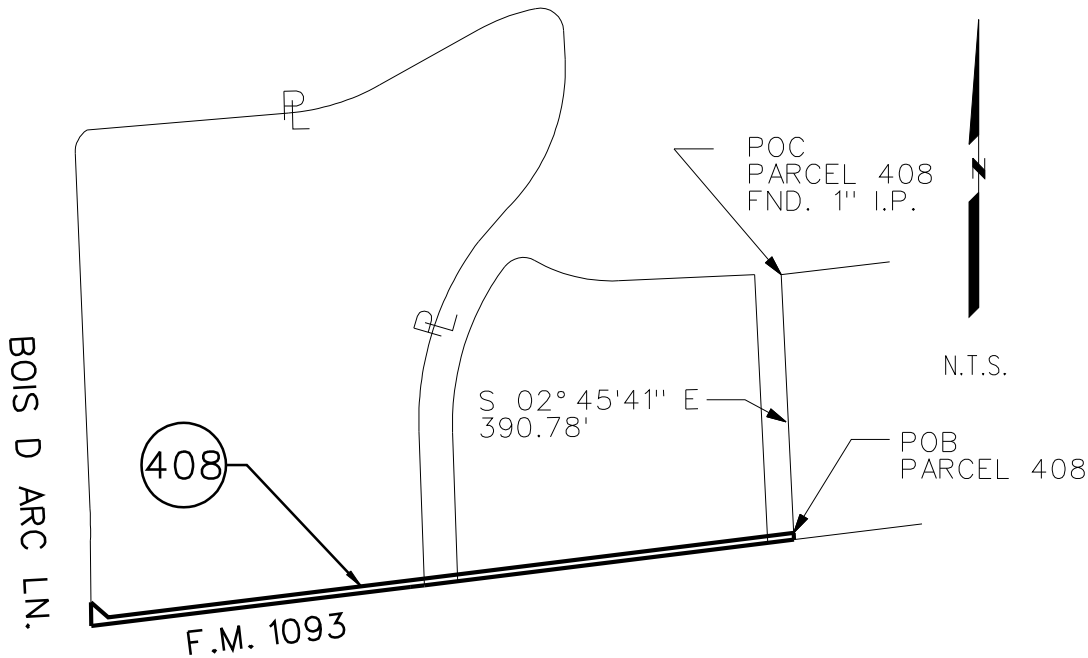

PARENT TRACT INSET

NOTES:

1. A PROPERTY DESCRIPTION OF EVEN DATE WAS PREPARED IN CONJUNCTION WITH THIS PARCEL PLAT.
2. ** THE MONUMENT DESCRIBED AND SET MAY BE REPLACED WITH A TxDOT TYPE II RIGHT-OF-WAY MARKER UPON COMPLETION OF THE HIGHWAY CONSTRUCTION PROJECT UNDER THE SUPERVISION OF A REGISTERED PROFESSIONAL LAND SURVEYOR, EITHER EMPLOYED OR RETAINED BY TxDOT.
3. ALL BEARINGS AND COORDINATES ARE BASED ON THE TEXAS COORDINATE SYSTEM, SOUTH CENTRAL ZONE, NAD 83 (1993 ADJ.). ALL DISTANCES AND COORDINATES SHOWN ARE SURFACE AND MAY BE CONVERTED TO GRID BY DIVIDING BY A COMBINED ADJUSTMENT FACTOR OF 1.00013.
4. ALL COORDINATES AND ELEVATIONS SHOWN HEREON ARE ESTABLISHED FROM TxDOT CONTROL MONUMENTS H-3, H-4, H-5, AND H-13 PREPARED BY COSTELLO, INC. DATED FEBRUARY 23, 2000 AND CONTROL MONUMENTS H-5A AND H-5B PREPARED BY WEISSER ENGINEERING COMPANY DATED OCTOBER 2006.
5. ABSTRACTING PERFORMED BY: POSTLE PROPERTY SERVICES 12/2013 TO 01/2014 AND UPDATED ON 07/2015.
6. GROUND SURVEY PERFORMED 03/2012., 09/2014 & 07/2015.



CONVENTIONAL SIGNS:

- EXISTING RIGHT-OF-WAY LINE
- ACCESS DENIAL LINE
- PROPOSED RIGHT-OF-WAY LINE
- PROPERTY LINE
- SURVEY LINE

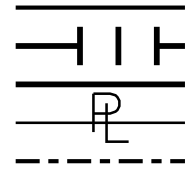

401 DENOTES PARCEL No.



3 DENOTES BEARING AND DISTANCE NOTE No.



- SET 5/8" I.R. W/TxDOT ALUM. CAP (SEE NOTE 2)
- SET 5/8" I.R. W/TxDOT ALUM. CAP (STAMPED "ADL")
- FOUND 5/8" I.R. W/TxDOT ALUM. CAP
- SET (AS INDICATED)
- FOUND (AS INDICATED)

- **
- ADL
-
-
-

LEGEND:

- C.F. NO. =CLERK'S FILE NUMBER
- F.C. NO. =FILM CODE NUMBER
- O.P.R.F.B.C =OFFICIAL PUBLIC RECORDS OF FORT BEND COUNTY
- F.B.C.P.R. =FORT BEND COUNTY PLAT RECORDS
- F.B.C.D.R. =FORT BEND COUNTY DEED RECORDS
- F.B.C.C.R. =FORT BEND COUNTY COURT RECORDS
- F.B.C.D.C.R. =FORT BEND COUNTY DISTRICT COURT RECORDS

REVISED: 11/12/2016 - INCREASED ACREAGE

EXISTING	TAKING AC/SF	REMAINING
124.49	0.2511 AC 10,939 SF	124.24 LT.
 19500 Park Row, Suite 100 Houston, Texas 77084 (281) 579 - 7300 TBPLS Firm Reg No. 100518-00		
PARCEL PLAT SHOWING PARCEL 408 FM 1093, FORT BEND COUNTY, TEXAS		
DATE: 07/2015	SCALE: N.T.S.	JOB No.: EG676
RCSJ No.: 0543-02-072		DWG. No.: P-408-01

E. LATHAM SURVEY, A-50

RESTRICTED RESERVE "C"
LAMAR C.I.S.D. HIGH SCHOOL NO 5 COMPLEX
File No. 20110054
F.B.C.P.R.

10' Stm Swr Esmt
File No. 2011084250
O.P.R.F.B.C.
CALLED 124.49 ACRES
LAMAR CONSOLIDATED
INDEPENDENT SCHOOL DISTRICT
FILE NO. 2008129534
DATE: DECEMBER 15, 2008
O.P.R.F.B.C.

BOIS D ARC LN.
(R.O.W. VARIES)
CLERK'S FILE NO 20110054
F.B.C.P.R.

N 00° 32' 37" W-35.43'

EXISTING R.O.W.

S/O 165+52.79, 176.71' LT

S 48° 46' 03" E-33.80'

PROPOSED R.O.W.

N 83° 00' 31" E-473.15'

25' Bldg. Line.
File No. 20110054
F.B.C.P.R.

S 83° 00' 31" W-499.65'

EXISTING R.O.W.

FND. 5/8" I.P.

S/O 165+75.31, 151.50' LT

F.M. 1093

(120' R.O.W.)
VOL. 243, PG. 171
F.B.C.D.R.

20' W.L.E. & S.S.E.
File No. 20110054
F.B.C.P.R.

PC 167+14.85

PT 168+41.92

EXISTING R.O.W.

BASELINE

N 83° 00' 31" E

C-3

FM 1093 BASELINE CURVE DATA

166+00

C3
RADIUS = 14,100.00'
CENTRAL ANGLE = 00° 30' 59" (LT)
ARC LENGTH = 127.07'
TAN LENGTH = 63.53'
CHORD BEARING = N 82° 45' 02" E
CHORD DISTANCE = 127.07'
PI STATION = 167+78.39
PI N = 13,813,750.48
PI E = 2,957,065.55

SHEET 5 OF 7

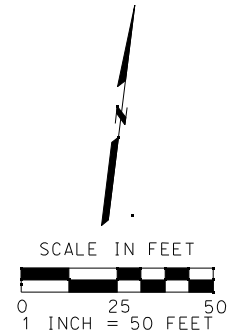

MATCH LINE SEE SHEET 6



19500 Park Row, Suite 100
Houston, Texas 77084
(281) 579 - 7300
TBPLS Firm Reg No. 100518-00

PARCEL PLAT SHOWING
PARCEL 408
FM 1093, FORT BEND COUNTY, TEXAS

DATE: 07/2015	SCALE: 1" = 50'	JOB No.: EG676
RCSJ No.: 0543-02-072	DWG. No.: P-408-02	

E. LATHAM SURVEY, A-50 LAMAR C.I.S.D. HIGH SCHOOL NO 5 COMPLEX

File No. 20110054

RESTRICTED RESERVE "C"

CALLLED 124.49 ACRES
LAMAR CONSOLIDATED
INDEPENDENT SCHOOL DISTRICT
FILE NO. 2008129534
DATE: DECEMBER 15, 2008
O.P.R.F.B.C.

F.B.C.P.R.

5' Bldg. Line.
File No. 20110054
F.B.C.P.R.

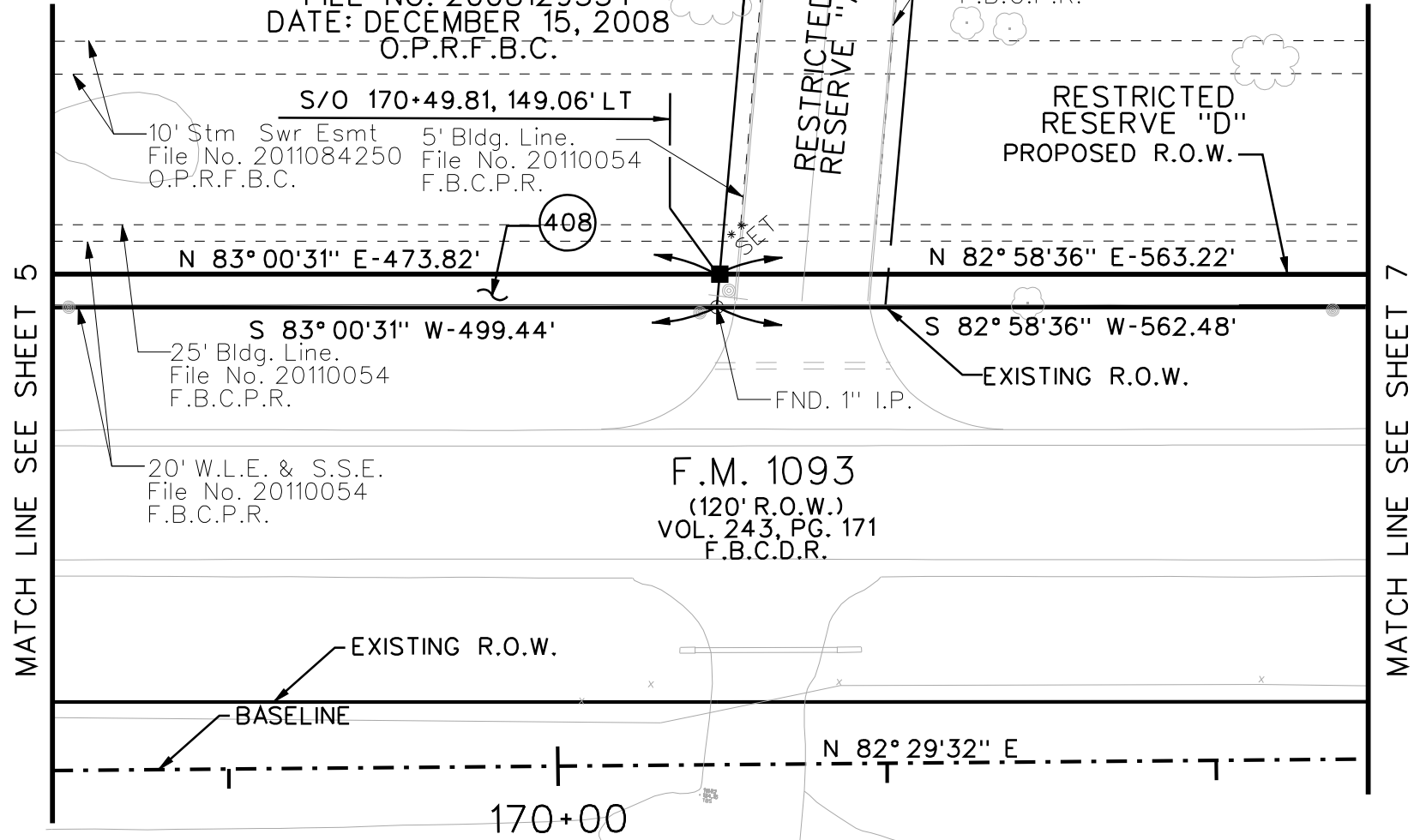
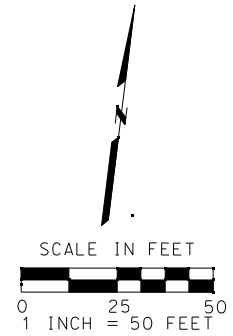

112

 WEISSER Engineering Co.	19500 Park Row, Suite 100 Houston, Texas 77084 (281) 579 - 7300 TBPLS Firm Reg No. 100518-00	
	PARCEL PLAT SHOWING PARCEL 408 FM 1093, FORT BEND COUNTY, TEXAS	
DATE: 07/2015	SCALE: 1" = 50'	JOB No.: EG676
RCSJ No.: 0543-02-072	DWG. No.: P-408-03	

E. LATHAM SURVEY, A-50

10' CNP Aerial Easement
File No. 2011070223
O.P.R.F.B.C.

10' Storm Sewer Easement
File No. 2011084250
O.P.R.F.B.C.

LAMAR C.I.S.D. HIGH
SCHOOL NO 5 COMPLEX

File No. 20110054
F.B.C.P.R.

5' Bldg. Line.
File No. 20110054
F.B.C.P.R.
10' CNP Aerial Easement
File No. 2011070223
O.P.R.F.B.C.

10' CNP Easement
File No. 2011070223
O.P.R.F.B.C.

P.O.B.
PARCEL 408
N=13,814,002.60
E= 2,957,874.16
S/O 176+11.70, 145.35' LT

P.O.C.
PARCEL 408
FND. 5/8" I.R.

5' Bldg. Line.
File No. 20110054
F.B.C.P.R.

5' Bldg. Line.
File No. 20130137
F.B.C.P.R.

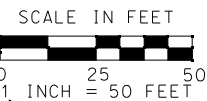

RESTRICTED RESERVE "D"

CALLLED 124.49 ACRES
LAMAR CONSOLIDATED
INDEPENDENT SCHOOL DISTRICT
FILE NO. 2008129534
DATE: DECEMBER 15, 2008
O.P.R.F.B.C.

(408)

PROPOSED R.O.W.
N 82° 58'36" E-563.22'

RESTRICTED RESERVE "A"

S 02° 45'41" E
390.78'

SET

S 82° 58'36" W-562.48'

EXISTING R.O.W.

25' Bldg. Line.
File No. 20110054
F.B.C.P.R.

S 02° 45'41" E
10.03'

120.00'

F.M. 1093
(120' R.O.W.)
VOL. 243, PG. 171
F.B.C.D.R.

175+00

MATCH LINE SEE SHEET 6

113



19500 Park Row, Suite 100
Houston, Texas 77084
(281) 579 - 7300
TBPLS Firm Reg No. 100518-00

PARCEL PLAT SHOWING
PARCEL 408
FM 1093, FORT BEND COUNTY, TEXAS

DATE: 07/2015	SCALE: 1" = 50'	JOB No.: EG676
RCSJ No.: 0543-02-072		DWG. No.: P-408-04

SHEET 7 OF 7

CONSIDER APPROVAL OF FINAL PAYMENT FOR THE FULSHEAR HIGH SCHOOL, LEAMAN JUNIOR HIGH SCHOOL, AND RENOVATIONS TO THE TRANSPORTATION FACILITY

RECOMMENDATION:

That the Board of Trustees approve the final payment of \$50,000 to Drymalla Construction Co., Inc. for the construction of Fulshear High School, Dean Leaman Junior High School, and the renovations to the Transportation Facility.

IMPACT/RATIONALE:

Drymalla Construction Co., Inc. was the contractor for the construction of the Fulshear High School, Dean Leaman Junior High School, and the renovations to the Transportation Facility. This project was substantially complete July 1, 2016.

PROGRAM DESCRIPTION:

Upon approval Drymalla Construction Co., Inc. will be paid 100% for the three projects.

Submitted by: Kevin McKeever, Administrator for Operations
Ed Bailey, Gilbane

Recommended for approval:



Dr. Thomas Randle
Superintendent

APPLICATION AND CERTIFICATE FOR PAYMENT

AIA DOCUMENT G702/CMa

CONSTRUCTION MANAGER-ADVISER EDITION

PAGE ONE OF _____ PAGES

TO OWNER: PROJECT: Fulshear High School
 LAMAR C.I.S.D. Leaman Junior High
 3911 Avenue I Sat Trans Center
 Rosenberg, Texas 77471

APPLICATION NO: 29 Distribution to:
 OWNER
 CONSTRUCTION
 PROJECT NO: 09/30/16 MANAGER
 ARCHITECT
 CONTRACTOR
 CONTRACT DATE:

FROM CONTRACTOR: Drymalla Construction Co., Inc.
 PO Box 698
 Columbus, Texas 78934
 VIA CONSTRUCTION MANAGER:
 CONTRACT FOR: New Construction VIA ARCHITECT: PBK Architects

CONTRACTOR'S APPLICATION FOR PAYMENT

Application is made for payment, as shown below, in connection with the Contract. Continuation Sheet, AIA Document G703, is attached.

1. ORIGINAL CONTRACT SUM \$ 107,208,336.00
2. Net change by Change Orders \$ 584,433.00
3. CONTRACT SUM TO DATE (Line 1 + 2) \$ 107,792,769.00
4. TOTAL COMPLETED & STORED TO DATE (Column G on G703) \$ 107,792,769.00
5. RETAINAGE:
 - a. % of Completed Work \$ _____
 - (Column D + E on G703)
 - b. % of Stored Material \$ _____
 - (Column F on G703)
 - Total Retainage (Lines 5a + 5b or Total in Column I of G703) \$ 0.00
6. TOTAL EARNED LESS RETAINAGE (Line 4 less Line 5 Total) \$ 107,792,769.00
7. LESS PREVIOUS CERTIFICATES FOR PAYMENT (Line 6 from prior Certificate) \$ 107,742,769.00
8. CURRENT PAYMENT DUE \$ 50,000.00
9. BALANCE TO FINISH, INCLUDING RETAINAGE (Line 3 less Line 6) \$ 0.00

The undersigned Contractor certifies that to the best of the Contractor's knowledge, information and belief the Work covered by this Application for Payment has been completed in accordance with the Contract Documents, that all amounts have been paid by the Contractor for Work for which previous Certificates for Payment were issued and payments received from the Owner, and that current payment shown herein is now due.

CONTRACTOR: DRYMALLA CONSTRUCTION COMPANY, INC.

By: _____ Date: 10/11/16

State of: Texas County of: Colorado
 Subscribed and sworn to before me this 11th day of October 2016
 Notary Public, State of Texas
 My Commission Exp. 03-19-2019
 DIANE E. WELCH

CERTIFICATE FOR PAYMENT

In accordance with the Contract Documents, based on on-site observations and the data comprising this application, the Construction Manager and Architect certify to the Owner that to the best of their knowledge, information and belief the Work has progressed as indicated, the quality of the Work is in accordance with the Contract Documents, and the Contractor is entitled to payment of the AMOUNT CERTIFIED.

AMOUNT CERTIFIED \$ 50,000.00

(Attach explanation if amount certified differs from the amount applied for. Initial all figures on this Application and on the Continuation Sheet that changed to conform to the amount certified)

CONSTRUCTION MANAGER: Drymalla Construction Company, Inc.

By: _____ Date: 10/11/16

ARCHITECT: PBK Architects
 By: _____ Date: 10/11/16

This Certificate is not negotiable. The AMOUNT CERTIFIED is payable only to the Contractor named herein. Issuance, payment and acceptance of payment are without prejudice to any rights of the Owner or Contractor under this Contract.

CHANGE ORDER SUMMARY	ADDITIONS	DEDUCTIONS
Total changes approved in previous months by Owner	\$584,433.00	\$0.00
Total approved this Month	0.00	0.00
TOTALS	\$584,433.00	\$0.00
NET CHANGES by Change Order	\$584,433.00	

AIA DOCUMENT G702/CMa - APPLICATION AND CERTIFICATE FOR PAYMENT - CONSTRUCTION MANAGER-ADVISER EDITION - 1992 EDITION - AIA ©1992

THE AMERICAN INSTITUTE OF ARCHITECTS, 1745 NEW YORK AVE., N.W., WASHINGTON, DC 20006-5292

Users may obtain validation of this document by requesting of the license a completed AIA Document D401 - Certification of Document's Authenticity

**CONSIDER APPROVAL OF REVISED DISTRICT RECORDS RETENTION SCHEDULE
FOR GENERAL RECORDS (GR), SCHOOL DISTRICT RECORDS (SD), AND
RECORDS OF ELECTIONS AND VOTER REGISTRATION (EL)**

RECOMMENDATION:

That the Board of Trustees approve the records retention schedules for Local Schedule of General Records, Records of Public School Districts and Records of Elections.

IMPACT/RATIONALE:

The Local Government Records Act of 1989, Chapter 201.002, mandates that all state and local government agencies have a records management program capable of providing efficient management of local government records in order to effectively and economically operate their agency and to preserve important documents for historical purposes.

PROGRAM DESCRIPTION:

Lamar CISD has not made a major revision to its records retention policy or schedule for a number of years. After Board approval, the District will submit the schedules and appropriate documentation to the Texas State Library and Archives Commission as required by law. The policies will be posted on the District website and available to the general public. The records retention schedules will be provided under separate cover.

Submitted by: Dr. Kathleen Bowen, Chief Human Resources Officer
Christine Muzik, Assistant Director of Staffing & Records Mgt.

Recommended for approval:



Dr. Thomas Randle
Superintendent

INFORMATION ITEM: SCHOOL BOARD RECOGNITION MONTH

January 2017 is School Board Recognition Month—a great time to focus on the crucial role an elected Board of Trustees plays in our communities and schools. School board members are the largest group of publicly-elected officials in Texas.

School board members exemplify local citizen control and decision-making in education. They volunteer hundreds of hours and an immeasurable amount of energy to assure our schools are providing the best education possible for the children of our community.

Here are some reasons we are taking this opportunity to show them our appreciation during School Board Recognition Month in January:

- School board members are citizens whose decisions affect our children—what they learn, who will teach them and what kinds of facilities house their classrooms. These are men and women elected to establish the policies that provide the framework for our public schools. They represent us and take this responsibility seriously by attending lengthy—sometimes challenging—meetings, conferences and institutes. They also broaden their knowledge about education during numerous conversations about the schools and in sessions before the Texas Legislature.
- Our school board is one of more than 1,000 such boards across the state. These boards enable us to have local control of public schools, meaning that decisions are made by local, elected representatives who understand the community's unique problems, values, culture and circumstances.
- Too often we neglect to recognize the dedication and hard work of these men and women who represent us. The staff and students of our school district are asking all local citizens to take a moment to tell a school board member "thanks for caring about our children's education." So, many thanks to the dedicated men and women who make it possible for local citizens to have a say about education in our communities. We salute the public servants of Lamar CISD whose dedication and civic responsibility make local control of public schools in our community possible. We applaud them for their vision and voice to help shape a better tomorrow.

Resource Persons: Dr. Thomas Randle, Superintendent
Mike Rockwood, Executive Director of Community Relations

Resolution

WHEREAS, the mission of the public schools is to meet the diverse educational needs of all children and to empower them to become competent, productive contributors to a democratic society and an ever-changing world; and

WHEREAS, local school board members are committed to children and believe that all children can be successful learners and that the best education is tailored to the individual needs of the child; and

WHEREAS, local school board members work closely with parents, educational professionals, and other community members to create the educational vision we want for our students; and

WHEREAS, local school board members are responsible for ensuring the structure that provides a solid foundation for our school system; and

WHEREAS, local school board members are strong advocates for public education and are responsible for communicating the needs of the school district to the public and the public's expectations to the district;

THEREFORE, I do hereby declare my appreciation to the members of the Lamar Consolidated Independent School District Board of Trustees and proclaim the month of January, 2017 as SCHOOL BOARD RECOGNITION MONTH in Lamar CISD and urge all citizens to join in recognizing the dedication and hard work of local school board members and in working with them to mold an education system that meets the needs of both today's and tomorrow's children.

Signed this 15th day of December, 2016 by Dr. Thomas Randle.



Thomas Randle

Thomas Randle, Ed.D.
Superintendent of Schools

INFORMATION ITEM: REPORT ON BOARD MEMBER TRAINING

School board members are required by Texas law and State Board of Education rule to participate in three types of continuing education: an orientation to local district policy and to the laws affecting public education in Texas; an annual team building activity, taken in conjunction with the rest of the board and the superintendent; and a specified number of hours each year in areas of special need. Board members determine needs with their board annually by reviewing the Framework for School Board Development, a document that outlines the tasks an effective board performs in its governing capacity. Continuing education courses that address these needs are available through a variety of sources.

Annually, the current president of each local Board of Trustees shall make an announcement stating Board members who have met the required hours of training and who have not met their basic obligation and expectation of the State Board of Education. The president shall cause the minutes of the local board to reflect the board members who have and who have not completed the required training and shall make this information available to the local media.

As of this date, the Lamar CISD Board members have the following current (since last year’s report) and accumulated certified training credit:

	Current	Accumulated	Total
Kay Danziger	28.50	103.25	131.75
Anna Gonzales		59.75	59.75
Tyson Harrell	12.50	23.50	36.00
Kathryn Kaminski	28.25	115.25	143.50
Melisa Roberts	9.75	31.50	41.25
James Steenbergen	22.25	33.50	55.75
Frank Torres		13.00	13.00

Resource Person: Dr. Thomas Randle, Superintendent

INFORMATION ITEM: STEWARDSHIP REPORT

The Stewardship Report has been updated to reflect the 2015-2016 school year and to provide information regarding *academic improvement, financial strength* and *organizational excellence*. While this report doesn't include every aspect of our organization—it does provide a glimpse of what's being done for the students and taxpayers of Lamar CISD.

Resource Person: Dr. Thomas Randle, Superintendent

**INFORMATION ITEM: LAMAR EDUCATIONAL AWARDS FOUNDATION
(L.E.A.F.) UPDATE**

The Lamar Educational Awards Foundation awarded \$339,455 in November to Lamar CISD campuses. The L.E.A.F. “Grant Express” visited 38 campuses and awarded 173 grants to Lamar CISD teachers. Since 2000, L.E.A.F. has awarded over \$2,929,355 in teaching grants to Lamar CISD campuses and \$52,250 in college scholarships to Lamar CISD graduates and para-professionals.

Year	Number of teaching grants	Total amount
2000	72	\$ 32,559.34
2001	37*	\$ 44,101.33
2002	41	\$ 50,536.27
2003	47	\$ 68,153.01
2004	57	\$ 87,036.00
2005	89	\$138,013.09
2006	101	\$150,665.00
2007	101	\$161,045.00
2008	100	\$171,701.68
2009	112	\$184,329.18
2010	107	\$190,762.00
2011	105	\$203,660.00
2012	111	\$217,537.87
2013	133	\$253,288.00
2014	158	\$317,045.00
2015	175	\$319,468.00
2016	173	\$339,455.00

*Grant amounts were raised during 2001 from \$500 per grant to \$1000 for individual teacher and \$3000 for grade level.

Resource Person: Janice Knight, Executive Director of L.E.A.F.
Mike Rockwood, Executive Director of Community Relations

**INFORMATION ITEM: TAX COLLECTION REPORT
(AS OF NOVEMBER 30, 2016)**

- Exhibit "A" gives the LCISD collections made during the month of November 30, 2016.
- Exhibit "B" gives the total LCISD collections made this school year from September 1, 2016 through August 31, 2017.
- Exhibit "C" shows the LCISD collections made month-by-month of the 2016-17 roll as compared to prior years. Through November 30, 2016, LCISD had collected 3.2 % of the 2016-17 roll.
- Exhibit "D" shows the total collections made as compared to the amount that was budgeted for 2016-2017.
- Exhibit "E" shows the LCISD tax collection analysis for the last six years.

Resource Person: Jill Ludwig, CPA, RTSBA, Chief Financial Officer

**Lamar Consolidated ISD
Tax Collections
November 2016**

Exhibit A

Year	Taxes Paid	Penalty & Interest	Collection Fees	Total Payments	General Fund Taxes Paid	General Fund P & I & Collection Fees	Debt Service Taxes Paid	Debt Service P & I & Collection Fees
16	\$ 6,415,679.23	\$ -	\$ -	\$ 6,415,679.23	\$ 4,800,278.04	\$ -	\$ 1,615,401.19	\$ -
15	\$ 62,438.46	\$ 15,379.90	\$ 17,396.11	\$ 95,214.47	\$ 46,717.12	\$ 28,903.54	\$ 15,721.34	\$ 3,872.47
14	\$ 42,442.48	\$ 3,849.89	\$ 3,374.08	\$ 49,666.45	\$ 31,755.84	\$ 6,254.62	\$ 10,686.64	\$ 969.35
13	\$ 39,919.84	\$ 3,146.33	\$ 2,280.76	\$ 45,346.93	\$ 29,868.47	\$ 4,634.87	\$ 10,051.37	\$ 792.22
12	\$ 40,620.96	\$ 3,491.38	\$ 2,210.38	\$ 46,322.72	\$ 30,393.02	\$ 4,822.65	\$ 10,227.94	\$ 879.11
11	\$ 40,710.60	\$ 3,304.51	\$ 1,874.23	\$ 45,889.34	\$ 29,874.35	\$ 4,299.14	\$ 10,836.25	\$ 879.60
10	\$ 23,717.85	\$ 3,091.69	\$ 1,480.90	\$ 28,290.44	\$ 17,729.96	\$ 3,792.04	\$ 5,987.89	\$ 780.55
09	\$ 8,714.29	\$ 7,542.56	\$ 3,208.01	\$ 19,464.86	\$ 6,850.09	\$ 9,137.02	\$ 1,864.20	\$ 1,613.55
08	\$ 818.33	\$ 780.86	\$ 315.37	\$ 1,914.56	\$ 643.26	\$ 929.18	\$ 175.07	\$ 167.05
07	\$ 644.59	\$ 687.47	\$ 259.23	\$ 1,591.29	\$ 496.74	\$ 789.04	\$ 147.85	\$ 157.66
06	\$ 974.31	\$ 1,162.79	\$ 422.92	\$ 2,560.02	\$ 837.32	\$ 1,422.23	\$ 136.99	\$ 163.48
05	\$ 577.04	\$ 750.00	\$ 261.94	\$ 1,588.98	\$ 509.85	\$ 924.63	\$ 67.19	\$ 87.31
04	\$ 1,285.05	\$ 1,919.13	\$ 638.83	\$ 3,843.01	\$ 1,135.46	\$ 2,334.58	\$ 149.59	\$ 223.38
03	\$ 783.41	\$ 1,242.71	\$ 302.57	\$ 2,328.69	\$ 705.99	\$ 1,422.47	\$ 77.42	\$ 122.81
02	\$ 395.14	\$ 656.47	\$ 156.40	\$ 1,208.01	\$ 356.10	\$ 747.99	\$ 39.04	\$ 64.88
01	\$ 405.04	\$ 711.91	\$ 165.46	\$ 1,282.41	\$ 365.01	\$ 807.02	\$ 40.03	\$ 70.35
00	\$ 373.52	\$ 724.63	\$ 164.73	\$ 1,262.88	\$ 332.51	\$ 809.81	\$ 41.01	\$ 79.55
99	\$ 360.01	\$ 741.62	\$ 165.24	\$ 1,266.87	\$ 325.31	\$ 835.38	\$ 34.70	\$ 71.48
98	\$ 367.11	\$ 801.53	\$ 175.31	\$ 1,343.95	\$ 339.40	\$ 916.34	\$ 27.71	\$ 60.50
97	\$ 377.24	\$ 869.68	\$ 187.03	\$ 1,433.95	\$ 348.77	\$ 991.07	\$ 28.47	\$ 65.64
96	\$ 32.92	\$ 79.67	\$ 16.89	\$ 129.48	\$ 29.89	\$ 89.22	\$ 3.03	\$ 7.34
Totals	\$ 6,681,637.42	\$ 50,934.73	\$ 35,056.39	\$ 6,767,628.54	\$ 4,999,892.50	\$ 74,862.84	\$ 1,681,744.92	\$ 11,128.28

**Lamar Consolidated ISD
Tax Collections
September 1, 2016-August 31, 2017
(Year-To-Date)**

Exhibit B

Year	Original Tax	Adjustments	Adjusted Tax	Taxes Paid	Penalty & Interest	Collection Fees	Total Payments	Total Taxes 11/30/2016
16	\$ 190,749,742.17	\$ 7,695,126.82	\$ 198,444,868.99	\$ 6,415,679.23	\$ -	\$ -	\$ 6,415,679.23	\$ 192,029,189.76
15	\$ 1,461,782.15	\$ (30,564.41)	\$ 1,431,217.74	\$ 347,066.26	\$ 69,988.04	\$ 87,943.32	\$ 504,997.62	\$ 1,084,151.48
14	\$ 542,294.32	\$ 49,179.74	\$ 591,474.06	\$ 116,150.06	\$ 19,055.68	\$ 15,354.89	\$ 150,560.63	\$ 475,324.00
13	\$ 376,208.38	\$ 31,388.52	\$ 407,596.90	\$ 56,937.50	\$ 6,621.31	\$ 4,702.67	\$ 68,261.48	\$ 350,659.40
12	\$ 351,985.57	\$ 54,655.44	\$ 406,641.01	\$ 81,681.10	\$ 7,375.80	\$ 4,532.99	\$ 93,589.89	\$ 324,959.91
11	\$ 306,018.43	\$ 52,546.44	\$ 358,564.87	\$ 79,181.55	\$ 5,877.69	\$ 3,263.20	\$ 88,322.44	\$ 279,383.32
10	\$ 239,335.19	\$ 8,987.94	\$ 248,323.13	\$ 45,600.69	\$ 3,930.19	\$ 1,947.54	\$ 51,478.42	\$ 202,722.44
09	\$ 180,590.36	\$ (1,218.87)	\$ 179,371.49	\$ 9,979.73	\$ 8,680.44	\$ 3,653.93	\$ 22,314.10	\$ 169,391.76
08	\$ 166,608.20	\$ (137.93)	\$ 166,470.27	\$ 2,294.39	\$ 2,301.69	\$ 850.95	\$ 5,447.03	\$ 164,175.88
07	\$ 184,194.57	\$ (137.93)	\$ 184,056.64	\$ 1,048.95	\$ 1,148.18	\$ 425.78	\$ 2,622.91	\$ 183,007.69
06	\$ 100,034.63	\$ (50.14)	\$ 99,984.49	\$ 3,436.85	\$ 4,105.17	\$ 1,467.71	\$ 9,009.73	\$ 96,547.64
05	\$ 136,302.28	\$ (55.00)	\$ 136,247.28	\$ 706.57	\$ 930.76	\$ 323.89	\$ 1,961.22	\$ 135,540.71
04	\$ 59,637.69	\$ (55.00)	\$ 59,582.69	\$ 3,036.00	\$ 4,594.51	\$ 1,524.11	\$ 9,154.62	\$ 56,546.69
03	\$ 45,396.95	\$ (53.92)	\$ 45,343.03	\$ 2,707.04	\$ 4,414.12	\$ 1,066.68	\$ 8,187.84	\$ 42,635.99
02	\$ 30,765.07	\$ (53.92)	\$ 30,711.15	\$ 1,591.65	\$ 2,763.15	\$ 598.79	\$ 4,953.59	\$ 29,119.50
01	\$ 28,187.49	\$ (52.44)	\$ 28,135.05	\$ 1,517.06	\$ 2,801.87	\$ 645.60	\$ 4,964.53	\$ 26,617.99
00	\$ 24,848.63	\$ (48.54)	\$ 24,800.09	\$ 1,534.72	\$ 3,019.70	\$ 674.62	\$ 5,229.04	\$ 23,265.37
99	\$ 25,968.92	\$ (12.28)	\$ 25,956.64	\$ 2,123.41	\$ 4,489.07	\$ 991.72	\$ 7,604.20	\$ 23,833.23
98	\$ 17,522.54	\$ (4.77)	\$ 17,517.77	\$ 1,850.59	\$ 4,134.22	\$ 897.74	\$ 6,882.55	\$ 15,667.18
97	\$ 15,955.33	\$ -	\$ 15,955.33	\$ 2,079.89	\$ 4,899.60	\$ 1,046.91	\$ 8,026.40	\$ 13,875.44
96	\$ 8,752.54	\$ -	\$ 8,752.54	\$ 1,057.70	\$ 2,631.31	\$ 553.36	\$ 4,242.37	\$ 7,694.84
95	\$ 4,709.94	\$ -	\$ 4,709.94	\$ 976.44	\$ 2,548.51	\$ 528.74	\$ 4,053.69	\$ 3,733.50
94 & prior	\$ 18,618.14	\$ (18.00)	\$ 18,600.14	\$ 3,076.97	\$ 8,805.06	\$ 1,782.30	\$ 13,664.33	\$ 15,523.17
Totals	\$195,075,459.49	\$7,859,421.75	\$202,934,881.24	\$7,181,314.35	\$175,116.07	\$134,777.44	\$7,491,207.86	\$195,753,566.89

**LAMAR CONSOLIDATED INDEPENDENT SCHOOL DISTRICT
TAX COLLECTION ANALYSIS
PERCENT Y-T-D BY MONTH
FOR CURRENT LEVY ONLY**

MONTH	2016-2017	2015-2016	2014-2015	2013-2014	2012-13	2011-12	2010-11	2009-10	2008-09	2007-08	2006-07	2005-06
SEPT	0.0%	0.0%	0.0%	0.0%	0.0%	0.0%	0.0%	0.0%	0.0%	0.0%	0.0%	0.0%
OCT	0.0%	0.1%	0.0%	0.1%	0.0%	0.0%	0.0%	0.0%	0.0%	0.0%	0.0%	0.0%
NOV	3.2%	3.2%	2.2%	7.4%	1.9%	2.6%	3.9%	1.9%	1.7%	2.8%	2.1%	1.0%
DEC		49.0%	45.3%	45.3%	33.1%	30.2%	33.3%	25.9%	35.4%	31.9%	29.7%	32.7%
JAN		83.9%	82.0%	86.2%	82.9%	82.3%	84.1%	80.7%	80.4%	59.6%	76.4%	73.6%
FEB		95.4%	95.1%	95.5%	95.5%	94.8%	94.3%	93.3%	92.8%	93.5%	93.3%	92.5%
MAR		96.9%	96.8%	97.0%	96.8%	96.4%	96.1%	95.0%	94.8%	95.1%	94.7%	94.3%
APR		97.6%	97.9%	97.8%	97.6%	97.1%	96.9%	96.0%	95.6%	95.9%	95.8%	95.2%
MAY		98.4%	98.2%	98.2%	98.1%	97.9%	97.6%	96.5%	96.4%	96.7%	96.5%	96.1%
JUNE		98.7%	98.6%	98.7%	98.6%	98.3%	98.2%	97.4%	97.2%	97.4%	97.3%	96.8%
JULY		99.0%	98.9%	99.0%	99.0%	98.7%	98.6%	98.0%	97.9%	98.0%	97.8%	97.4%
AUG		99.2%	99.0%	99.2%	99.1%	98.9%	98.8%	98.2%	98.2%	98.2%	98.2%	97.8%

**LAMAR CONSOLIDATED INDEPENDENT SCHOOL DISTRICT
2016-17 TAX COLLECTIONS
AS OF NOVEMBER 30, 2016**

TAX YEAR LCISD TAXES	SCHOOL YEAR	BUDGET AMOUNT	COLLECTIONS 11/30/2016	% OF BUDGET COLLECTED
2016	2016-2017	\$190,807,570	\$6,415,679	3.36%
2015 & Prior	2015-16 & Prior	\$2,150,000	\$765,635	35.61%
TOTAL		\$192,957,570	\$7,181,314	3.72%

**LAMAR CONSOLIDATED INDEPENDENT SCHOOL DISTRICT
TAX COLLECTION REPORT
AS OF NOVEMBER 30, 2016**

Exhibit E

SCHOOL YEAR TAX YEAR	2011-12 2011	2012-13 2012	2013-14 2013	2014-15 2014	2015-16 2015	2016-17 2016
COLLECTION YEAR						
1 Orig. Levy	\$ 132,226,943	\$ 136,145,655	\$ 142,546,726	\$ 153,118,133	\$ 173,016,530	\$ 190,749,742
1 Collections	\$ 136,117,707	\$ 140,561,034	\$ 148,220,912	\$ 160,220,428	\$ 178,028,559	\$ 6,415,679
Adj. To Roll	\$ 5,417,190	\$ 5,652,043	\$ 6,929,880	\$ 8,680,375	\$ 6,473,810	\$ 7,695,127
2 Collections	\$ 915,762	\$ 739,542	\$ 739,176	\$ 1,201,706	\$ 347,066	
Adj. To Roll	\$ (64,337)	\$ 65,612	\$ 242,601	\$ 165,920	\$ (30,564)	
3 Collections	\$ 286,833	\$ 315,459	\$ 333,212	\$ 116,150		
Adj. To Roll	\$ 162,075	\$ 445,748	\$ (49,699)	\$ 49,180		
4 Collections	\$ 308,264	\$ 252,058	\$ 56,938			
Adj. To Roll	\$ 518,252	\$ (88,980)	\$ 31,388			
5 Collections	\$ 232,737	\$ 81,681				
Adj. To Roll	\$ (92,801)	\$ 54,655				
6 Collections	\$ 79,181					
Adj. To Roll	\$ 52,546					
TOTAL:						
COLLECTIONS	\$ 137,940,484	\$ 141,949,774	\$ 149,350,238	\$ 161,538,284	\$ 178,375,625	\$ 6,415,679
ADJUSTED TAX ROLL	\$ 138,219,867	\$ 142,274,734	\$ 149,700,897	\$ 162,013,608	\$ 179,459,776	\$ 198,444,869
BALANCE TO BE COLLECTED	\$ 279,383	\$ 324,960	\$ 350,659	\$ 475,324	\$ 1,084,151	\$ 192,029,190
ADJ. TAXABLE VALUE	\$ 9,943,517,649	\$ 10,235,224,166	\$ 10,769,461,288	\$ 11,655,235,968	\$ 12,910,310,831	\$ 14,276,095,751
TOTAL % COLLECTIONS AS OF NOVEMBER 30, 2016	99.8%	99.8%	99.8%	99.7%	99.4%	3.2%
TAX RATE	1.39005	1.39005	1.39005	1.39005	1.39005	1.39005

INFORMATION ITEM: PAYMENTS FOR CONSTRUCTION PROJECTS

Below is a list of invoices that have been approved for payment.

BLS Construction (Ag Barn #2)	Application # 1	\$ 123,136.64
Bass Construction (Huggins ES Parent Drive)	Application # 1	\$ 181,949.70
Bass Construction (Huggins ES Parent Drive)	Application # 2	\$ 77,723.30
Drymalla Construction (Lindsey Elementary)	Application # 6	\$ 2,025,370.55
Engineered Air Balance (Bentley ES)	Application # 1	\$ 2,835.00
Estes, McClure & Assoc. (District Wide Chiller Replacements)	Application # 1	\$ 22,500.00
Estes, McClure & Assoc. (District Wide Chiller Replacements)	Application # 2	\$ 22,500.00
Estes, McClure & Assoc. (District Wide Chiller Replacements)	Application # 3	\$ 3,000.00
Gamma Construction (Bentley ES)	Application # 13	\$ 2,196,267.00
Gilbane (2011 Bond Program)	Application # 55	\$ 40,418.00
Hartfiel Architecture & Design (Districtwide Fence Improvements)	Application # 1	\$ 8,250.00
Miller Survey Group (Culver ES)	Application # 1	\$ 3,500.00
PBK Architects (Foster HS - Pool)	Application # 3	\$ 5,362.50

PBK Architects (Fulshear HS)	Application # 21	\$	33,174.28
PBK Architects (Fulshear HS – Pool)	Application # 3	\$	3,128.13
PBK Architects (George Ranch HS – Pool)	Application # 3	\$	3,128.13
PBK Architects (Leaman JHS)	Application # 19	\$	9,005.02
PBK Architects (Lindsey ES)	Application # 8	\$	43,532.17
PBK Architects (Lindsey ES - Reimbursables)	Application # 4	\$	2,500.00
PBK Architects (Transportation Satellite)	Application # 11	\$	4,976.11
PBK Architects (Traylor Stadium)	Application # 26	\$	2,565.00
Terracon (Ag Barn #2)	Application # 1	\$	2,270.00
Terracon (Bentley ES)	Application # 12	\$	2,852.00
Terracon (Huggins ES Parent Drive)	Application # 1	\$	1,332.00
Terracon (Huggins ES Parent Drive)	Application # 2	\$	1,236.75
Terracon (Lindsey ES)	Application # 6	\$	10,273.00
Terracon (Support Services)	Application # 1	\$	11,100.00
VLK Architects (Carter ES)	Application # 2	\$	14,602.50

VLK Architects (Carter ES – Reimbursables)	Application # 1	\$	1,001.65
VLK Architects (Huggins ES Parent Drive)	Application # 1	\$	38,188.80
VLK Architects (Huggins ES Parent Drive)	Application # 2	\$	1,310.40
VLK Architects (Huggins ES Parent Drive – Reimbursables)	Application # 1	\$	1,395.43
Vanir, Rice & Gardner (2014 Bond Program)	Application # 17	\$	222,584.00

Resource person: Kevin McKeever, Administrator for Operations



**11.C.#5a. – PLANNING
BOARD REPORT
DECEMBER 15, 2016**

**Monthly Report
2011 Bond Program**



Ag Barn #2 is a new 15,600 sf facility located on FM 359.



Current 2011 Bond Program Projects:

New AG Barn #2:

- ❖ Proposals from five contractors were received on July 26, 2016. BLS Construction was approved by the Board at the regular August meeting. Notice to proceed was issued October 5, 2016 (approximately one month later than anticipated).
- ❖ Plans were submitted and approved by FBC MUD No. 142. Approval letter was sent to FBC Engineering; however, the MUD Board is going to require annexation of the property before they will provide water/sewer service. This process is started and will be handled concurrently with Bentley ES.
- ❖ Plans were submitted and approved by FBC Engineering. A request for an early start was approved by the County Commissioner on October 4th. The full development permit was issued on 10/25/2016.
- ❖ The plat has been approved and signed by the FBC Commissioner’s Court.
- ❖ The project is on schedule and is approximately 19% complete.
- ❖ The site entrance from FM 359 has been constructed and inspected by TxDOT and the roadway to the building has been constructed. Site grading has been done, detention pond constructed and utilities have been installed except for the connection to MUD No. 142.
- ❖ The building pad has been excavated and is being constructed in accordance with recommendations from the geotechnical engineer. Piers have been drilled and poured. Grade beam construction will begin the week of 12/5.
- ❖ Plumbing rough-in is approximately 85% complete. Electrical rough-in will start the week of 12/5. Slab on grade should be poured shortly after the first of the year.



Adolphus Elementary

2011 Bond Closed Projects:

Adolphus Elementary

New 90,700 sf elementary school located in Longmeadow Farms Subdivision in Richmond, TX. The campus includes 42 classrooms with Promethean boards, gymnasium with stage, music room, library, play areas, teacher and visitor parking, and separate bus drop off areas.



Ag Barn renovations

Agricultural Barn Renovations

The renovation included adding a new 10' canopy around $\frac{3}{4}$ of the building, added ventilation fans, new men and women restroom facilities, an interior storage room, grading and drainage work around the building perimeter, new electronic gate software, additional security cameras, and new tarps for all of the animal pens.



George Ranch HS Shell Build-Out

George Ranch High School Build-Out

The project included the build-out of 14 standard classrooms and 4 science labs inside the existing high school building.



Polly Ryon Middle School

Polly Ryon Middle School

The project included a new 80,000 sf middle school campus located on the existing George Ranch HS complex in Richmond, TX. The facility includes 22 classrooms with SMART board technology, a cafeteria with performance stage, library, 5 science labs, dedicated fine arts rooms, visitor and staff parking and separate bus drop off areas.



Traylor Stadium Track & Turf

Traylor Stadium Track & Turf

The project included the replacement of the turf and subgrade for the competition football field, as well as installation of a new track surface.

District Competition Natatorium

The District Natatorium is a new 36,000 sf competition swimming facility with an eight lane heated pool, diving well, weight room, classrooms, offices, spectator seating and judges stands. The complex is located adjacent to Traylor Stadium in Rosenberg, TX.



BF Terry High School

George Junior High School



Lamar High School



Bowie Elementary School



Jackson Elementary School

Miscellaneous Renovations (2013) to Terry HS, Lamar HS, George JHS, Jackson ES & Bowie ES

Terry High School (Rosenberg, TX): Renovations included a 6,200 sf addition for 2 art rooms and 1 standard classroom; remodel of the CTE areas to include to new PLTW classrooms and shop area; remodel of the existing wood shop to include new storage, exterior doors and an added classroom; remodel of the existing Ag shop and classroom to include new welding stations and integrated oxygen/acetylene manifold system and a new canopy and graphics at the campus main entry. All classrooms received new marker boards and homeland security locksets. Additional project upgrades included resurfacing the existing tennis courts.

George Junior High School (Rosenberg, TX): Renovations included new paint and graphics in both gyms and floor resurfacing in the competition gym; chilled water piping was replaced throughout the school; remodel of the existing Ag shop, storage and office areas; additional security cameras were added and homeland security locksets were added to all classrooms. Additional project upgrades included floor resurfacing and repair in the competition gymnasium.

Lamar High School (Rosenberg, TX): Renovations to the CTE areas of the school included relocation of exhaust systems in the existing auto-tech shop; outfitting of lifts and exhaust for a future auto-tech shop expansion; repair and painting of the exterior yard vehicle canopy and fenced enclosure; new electronic gate for vehicle storage area; new exhaust hood system in the Ag shop and installation of an integrated oxygen/acetylene manifold system.

Bowie Elementary School (Rosenberg, TX): Renovations included replacement or modification of existing classroom casework; new classroom doors; a new sidewalk from the school to Ruby Street; ceiling tile replacement; grading and drainage work and all classrooms received homeland security locksets.

Jackson Elementary School (Rosenberg, TX): Renovations included a 470 sf kitchen addition with an office, laundry and restrooms; all flooring was replaced in the hallways with ceramic or vinyl tile; an additional canopy was installed outside the gymnasium; restrooms were renovated to remove trough urinals; various HVAC equipment was replaced; library doors were replaced and all classrooms received homeland security locksets. Additional project upgrades included new HVAC controls for the entire school.



Alternative Learning Center

Miscellaneous Renovations (2014) to Alternative Learning Center, Austin ES, Beasley ES, Foster HS, Lamar JHS, Lamar HS, Taylor Ray ES & Travis ES, --Closeout of the project is expected in January, 2015.

Alternative Learning Center (Rosenberg, TX): The project included a 2,770 sf addition for administrative offices, inspection, security and a clinic, as well as renovations to existing student restrooms, conversion of old offices to computer lab and conference areas, and ventilation, exhaust and new wood storage for the Ag shop.



Austin Elementary School

Austin Elementary School (Richmond, TX): The project included replacement of all air handlers; remodel of life skills storage area into a restroom; enclosure of existing mop sinks in mechanical rooms and removal/replacement of sidewalks around the perimeter of the building to address drainage issues.

Foster High School (Richmond, TX): Renovations to the Ag shop included additional welding stations with exhaust hoods, a new exterior canopy, covered material storage areas and installation of an integrated oxygen/acetylene manifold system.



Foster High School

Lamar High School (Rosenberg, TX): This project included replacement of two existing cooling towers at the Central plant serving the high school and junior high, as well as replacement of the boiler in the Lamar HS Fieldhouse.

Travis Elementary School (Rosenberg, TX): The project included a new parent drop-off drive and canopy along Avenue K; a new staff parking lot at the rear of the school; boiler replacement and tie in of a chilled water loop for the HVAC system.



Lamar High School

Beasley Elementary School (Beasley, TX): The project included the replacement of all air handlers in the building that had reached the end of their life cycle. (no photo)

Lamar Junior High School (Rosenberg, TX): The project included replacement of two boilers that had reached the end of their life cycle. (no photo)



Travis Elementary School

Taylor Ray Elementary School (Rosenberg, TX): Renovations consisted of the replacement of student restroom exhaust fans that had reached the end of their life cycle. (no photo)



Arredondo Elementary School

Arredondo Elementary School (Richmond TX):

A new 12 acre campus consisting of a 90,700 sf building, parking and play areas located in Summer Park subdivision in Richmond, TX



Traylor Stadium

The Traylor Stadium:

This project included demolition of existing concession and restroom facilities, as well as the construction of a new long jump area and 3 new restroom/concession and ticket booth buildings to serve the stadium. New fencing was installed and parking was reconfigured and striped.



Meyer Elementary

Miscellaneous Renovations (2015) to Campbell ES, Frost ES, Pink ES, Meyer ES, Dickinson ES, Williams ES, Smith ES, Navarro MS, Wessendorff MS & Seguin Early Childhood Center:

Campbell Elementary School (Sugar Land, TX) – Provided web-based HVAC Controls

Frost Elementary School (Richmond, TX) – Provided web-based HVAC Controls

Pink Elementary School (Richmond, TX) – Provided web-based HVAC Controls



Navarro MS

Meyer Elementary School (Richmond, TX) – Replaced existing electric drinking fountain with manual drinking fountain. Replaced existing boiler. Renovated an existing set of restrooms to meet ADA standards. Installed new canopy adjacent to existing canopy.

Dickinson Elementary School (Sugar Land, TX) – Installed new handicap accessible sink and free standing utility sink in art room. Replaced existing electric drinking fountain with manual drinking fountain. Replaced and relocated electric water heaters. Replaced existing boiler.



Dickinson Elementary

Williams Elementary School (Richmond, TX) – Upgraded exterior lighting.

Smith Elementary School (Rosenberg, TX) – Replaced existing boiler.

Navarro Middle School (Rosenberg, TX) – Replaced existing drainage area to resolve parking lot flooding. Installed new drive. Installed new wall pack lighting.

Wessendorff Middle School (Rosenberg, TX) – Replaced existing boiler.



Seguin Early Childhood Center

Seguin Early Childhood Center (Richmond, TX) – Installed new parking lot and canopy to provide safe drop-off area. Replaced existing electric drinking fountain with manual drinking fountain. Replaced windows in office and classroom areas.



Fulshear HS

Churchill Fulshear (Jr.) HS, Dean Leaman JHS, - is part of a new 101 acre campus in Fulshear, TX. It includes a 350,000 sf main building, 32,400 sf field house, teacher and student parking, separate bus drop-off, dual gymnasiums, dedicated CTE spaces, competition and practice ball fields, tennis courts, and band practice areas. Final payment on this board agenda.



Dean Leaman JHS



Field House

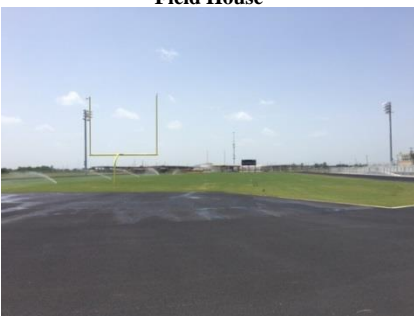

COMMUNITY SITES

- A Fort Bend County Fairgrounds
- B George Memorial Public Library
- C Oak Bend Medical Center
- D Rosenberg Civic Center

SECONDARY CAMPUSES

- H1 Foster HS
- H2 Fulshear HS
- H3 George Ranch HS
- H4 Lamar Consolidated HS
- H5 Terry HS
- J1 Briscoe JH
- J2 George JH
- J3 Lamar JH
- J4 Leaman JH
- J5 Reading JH
- M1 Navarro MS
- M2 Ryon MS
- M3 Wertheimer MS
- M4 Wessendorff MS

ELEMENTARY CAMPUSES

- E1 Adolphus ES
- E2 Arredondo ES
- E3 Austin ES
- E4 Beasley ES
- E5 Bentley ES
- E6 Bowie ES
- E7 Campbell ES
- E8 Dickinson ES
- E9 Frost ES
- E10 Hubenak ES
- E11 Huggins ES
- E12 Hutchison ES
- E13 Jackson ES
- E14 Long ES
- E15 McNeill ES
- E16 Meyer ES
- E17 Pink ES
- E18 Ray ES
- E19 Smith ES
- E20 Thomas ES
- E21 Travis ES
- E22 Velasquez ES
- E23 Williams ES
- EC1 Seguin Early Childhood Center

SPECIAL SITES

- S1 1621 Place
- S2 Administrative Annex
- S3 Alternative Learning Center
- S4 Brazos Crossing Administration Building
- S5 Development Center
- S6 Fort Bend Alternative School
- S7 Powell Point
- S8 Athletics/Traylor Stadium
- S9 Special Needs Center

DISTRICT MAP

Elementary, Middle, Junior High, High School and Special Sites
 3911 Avenue I ♦ Rosenberg, Texas 77471 ♦ 832-223-0000 (main) ♦ www.lcisid.org

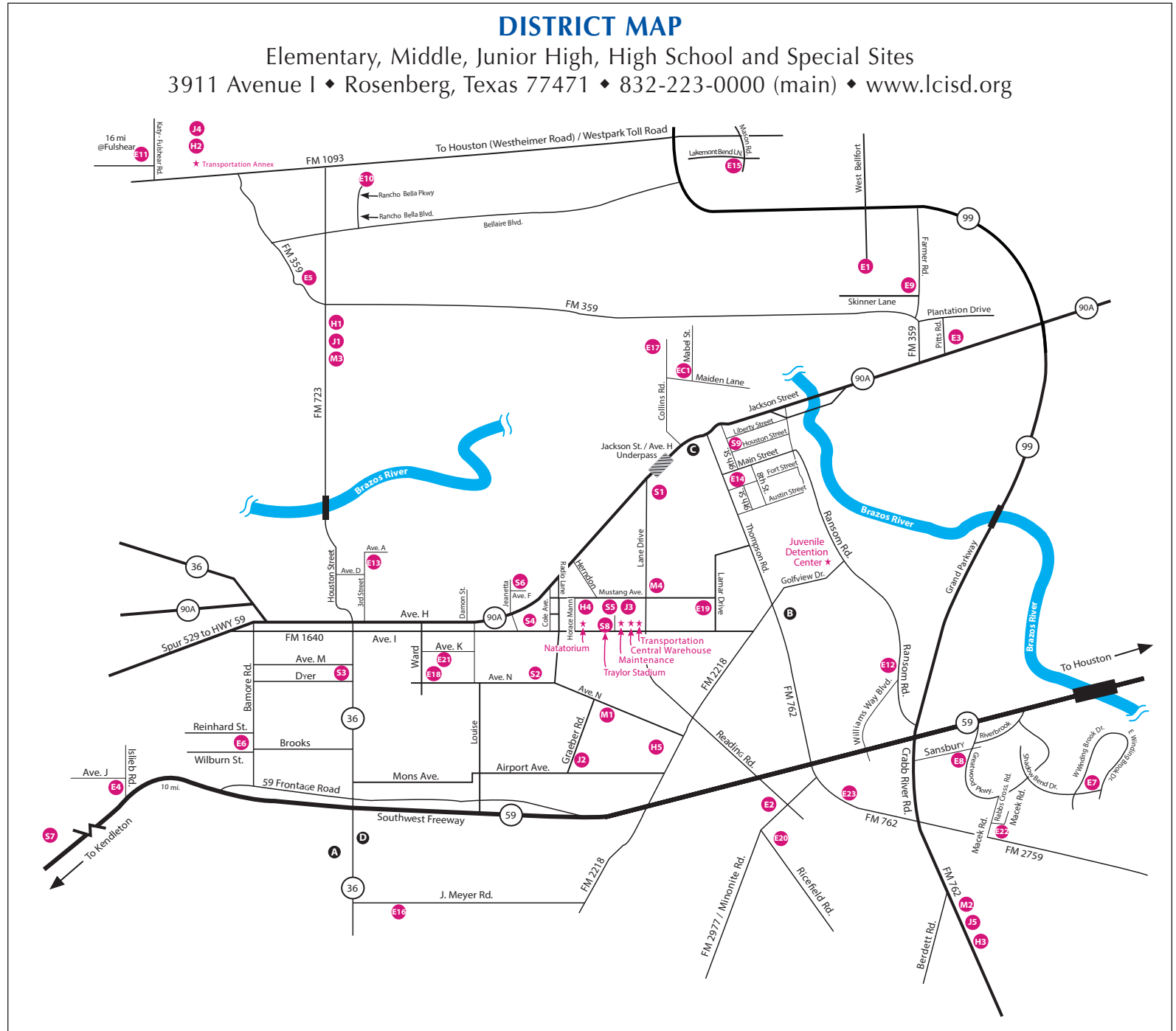

EXECUTIVE SUMMARY

Bond Sale 1	Current Budget	Committed	Projected Commitments	Actuals Paid	Estimated Cost at Completion
Carl Briscoe Bentley Elementary (#24)	22,010,055.00	20,585,993.25	1,424,061.75	12,777,232.37	22,010,055.00
Kathleen Joerger Lindsey Elementary (#25)	23,770,861.00	20,174,151.65	3,596,709.35	6,641,690.10	23,770,861.00
Don Carter Elementary School (#26)	24,959,404.00	2,238,086.00	22,721,318.00	959,907.00	24,959,404.00
FHS Baseball	40,000.00	29,250.00	10,750.00	29,250.00	40,000.00
FHS Water Plant	990,000.00	114,900.00	875,100.00	48,000.00	990,000.00
HVAC Web Controls	1,056,000.00	108,000.00	948,000.00	38,575.00	1,056,000.00
LCCHS Band Hall	700,000.00	74,975.00	625,025.00	37,767.50	700,000.00
Pink Elementary- Foundation	1,056,000.00	527,728.00	528,272.00	462,893.00	1,056,000.00
Practice Pool - Foster High School	8,855,872.00	930,598.00	7,925,274.00	95,575.00	8,855,872.00
Practice Pool - Fulshear High School	8,855,872.00	751,848.00	8,104,024.00	82,168.75	8,855,872.00
Practice Pool - George Ranch High School	8,855,872.00	751,748.00	8,104,124.00	81,385.75	8,855,872.00
Support Services Center	12,146,000.00	1,199,030.00	10,946,970.00	621,074.00	12,146,000.00
THS Band Hall	700,000.00	75,330.00	624,670.00	37,997.50	700,000.00
*THS Baseball	2,400,000.00	110,700.00	2,289,300.00	74,980.00	2,400,000.00
Sub Total - Bond Sale 1	116,395,936.00	47,672,337.90	68,723,598.10	21,988,495.97	116,395,936.00
Bond Sale 2					
Elementary 27	24,959,404.00	1,002,385.00	23,957,019.00	0.00	24,959,404.00
Elementary 28	26,207,374.00	1,002,385.00	25,204,989.00	0.00	26,207,374.00
James W. Roberts Middle School	22,342,493.00	893,700.00	21,448,793.00	0.00	22,342,493.00
Fulshear HS Shell	3,849,077.00	179,026.00	3,670,051.00	0.00	3,849,077.00
Satellite Ag Barn	3,786,750.00	189,000.00	3,597,750.00	0.00	3,786,750.00
Sub Total - Bond Sale 2	81,145,098.00	3,266,496.00	77,878,602.00	0.00	81,145,098.00
Grand Total	197,541,034.00	50,938,833.90	146,602,200.10	21,988,495.97	197,541,034.00

* Budget increased at August 18, 2016 Board Meeting

Additional Projects	Current Budget	Committed	Projected Commitments	Actuals Paid	Estimated Cost at Completion
Access Controls	800,000.00	0.00	800,000.00	0.00	800,000.00
Huggins Elementary School	700,000.00	672,447.00	27,553.00	214,068.00	700,000.00
Chiller Replacement	1,200,000.00	63,280.00	1,140,000.00	0.00	1,200,000.00
Site Lighting	1,600,000.00	0.00	1,600,000.00	0.00	1,600,000.00
Grand Total	4,300,000.00	735,727.00	3,567,553.00	214,068.00	4,300,000.00

PROGRAM OVERVIEW

Vanir | Rice & Gardner, A Joint Venture, is serving as the Program Managers for the 2014 Bond Program for Lamar CISD. In this role, we provide leadership for managing individual projects, and interface with architects and contractors. We are the liaison between LCISD Administration, Departments and Schools to coordinate all activities necessary to successfully complete each project.

We also provide program wide oversight and look for efficiencies, cost reduction and quality assurance opportunities.

Accomplishments This Month:

- Permanent power was connected at Bentley Elementary School
- Completed structural steel and roof installation at Lindsey Elementary School
- Completed phase 1 opening of the new parking lot at Huggins Elementary School
- Awarded the Chiller Replacement contract at six schools

CARL BRISCOE BENTLEY ELEMENTARY SCHOOL

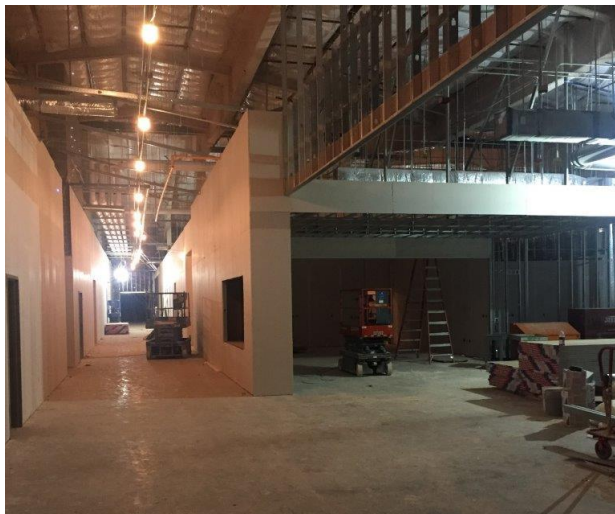

SCHEDULE MILESTONES

- Current Phase: Construction
- Construction Start: October 16, 2015
- Projected Completion: December 19, 2016

OVERVIEW

- Site paving is complete.
- Final grading is underway.
- Ventilation systems became operational.
- Interior finishes are being completed in many areas.
- Casework, painting, vinyl wall covering and ceilings are underway in all areas.
- FM 359 road widening and traffic signal improvements are underway.
- As of 11/30/16, the construction contract is approximately 85% complete.

KATHLEEN JOERGER LINDSEY ELEMENTARY SCHOOL



OVERVIEW

- Exterior steel framing is complete.
- Roofing is complete.
- Exterior board sheathing is 40% complete.
- Masonry at the gymnasium/cafeteria is 80% complete.
- Classroom walls are beginning to be installed.
- Installing piping and ductwork throughout building.
- As of 11/30/16, the construction contract is 45% complete.

SCHEDULE MILESTONES

- Current Phase: Construction
- Construction Start: April 22, 2016
- Substantial Completion: June 23, 2017

DON CARTER ELEMENTARY SCHOOL



OVERVIEW

- The Design Development phase continues to refine building systems and details.
- Working with District staff on building materials and learning spaces.
- A cost estimate is being prepared to confirm the design remains in budget.
- The District is continuing to perform their due diligence in evaluating the suitability of a proposed site for the new Carter Elementary School. Anticipate closing on site in January.
- The final site design is being coordinated with the developer for roadwork and driveway access.
- Topographic survey is complete.
- Geotechnical study is complete.

SCHEDULE MILESTONES

- Current Phase: Design
- Construction Start: 2nd Quarter 2017
- Construction Completion: Third Quarter 2018

SUPPORT SERVICES CENTER



Maintenance and Operations



Support Services

The Support Services facility project will provide space to expand Purchasing & Materials Management, Food Service Support, Maintenance & Operations, and Graphic Arts.

SCHEDULE MILESTONES

- Current Phase: Design
- Construction Start:
 - Phase 1: 2nd Quarter 2017
 - Phase 2: 1st Quarter 2018

OVERVIEW

- Cost estimates for the design of the facility have been finalized.
- A final direction on the scope of the project is pending a review by the District.

Phase 1

- Maintenance and Operations will be constructed on the new site.

Phase 2

- Existing structures currently housing M&O, Purchasing and Food Service will be renovated. A new dock area and enclosed link will be constructed between the two existing buildings enhancing access and providing additional parking for the football stadium.

PRACTICE POOLS

Foster High School

Fulshear High School

George Ranch High School

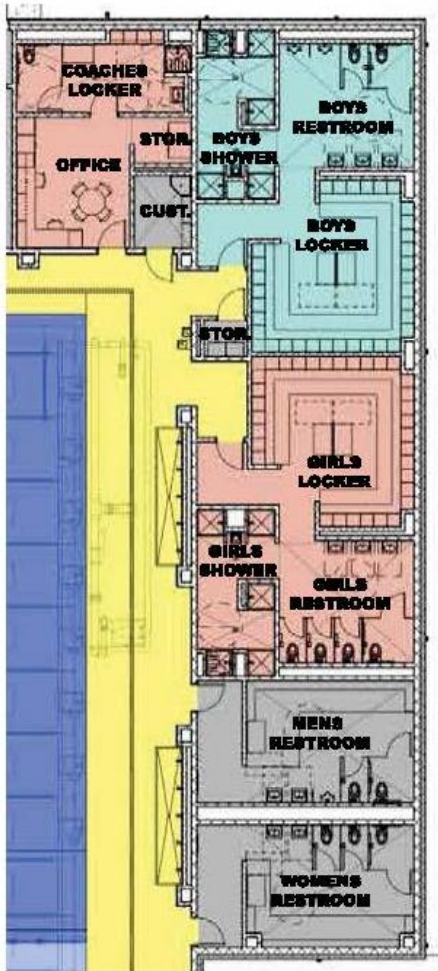

Enlarged Floor Plan

SCHEDULE MILESTONES

- Current Phase: Design Development
- Construction Start: 2nd Quarter 2017
- Construction Completion: 3rd Quarter 2018

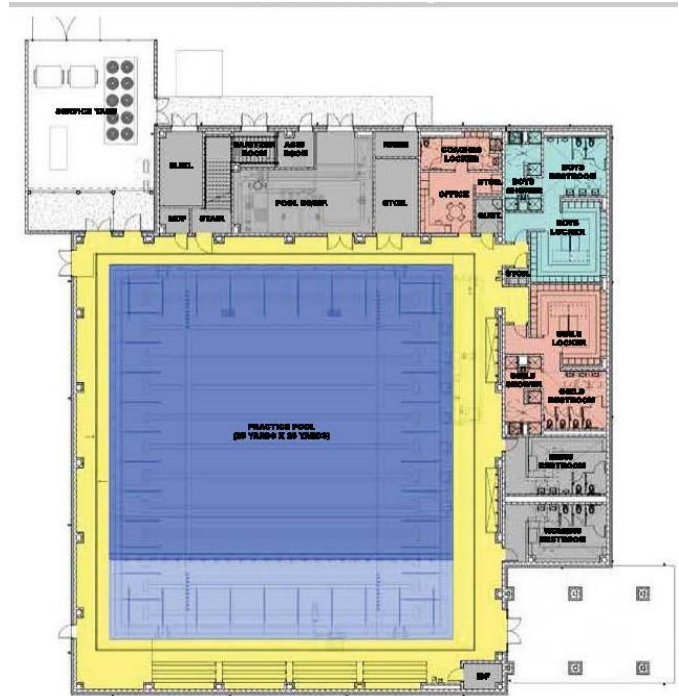

OVERVIEW

- Design Development phase continues.
- A Design Development cost estimate has been completed and is being reviewed for final adjustments.
- The pool layout has been adjusted for optimal viewing and judging by pool officials.
- Water flow tests have been performed on each campus to gather data regarding the existing water supply infrastructure.
- Mechanical, Electrical, Plumbing and Pool system designs are being further refined.

BASEBALL COMPLEX RENOVATIONS

Terry High School



SCHEDULE MILESTONES

- Current Phase: Pre-Bidding
- Construction Start: 1st Quarter 2017
- Substantial Completion: 3rd Quarter 2017

OVERVIEW

- The design has been completed for the Terry High School Baseball/Softball Complex improvements.
- Major elements include: new bleachers, new dugouts, new Ticket/Restroom/Concessions Building, new Press Boxes, new Softball Field Lighting, new Parking and Paving.
- The project has been advertised for Competitive Sealed Proposals to be received in December 2016.
- Anticipated contract award scheduled for January 2017.
- Construction is planned to begin in February 2017 and will be phased to work around the baseball and softball seasons.

BAND HALL EXPANSION

Lamar Consolidated High School

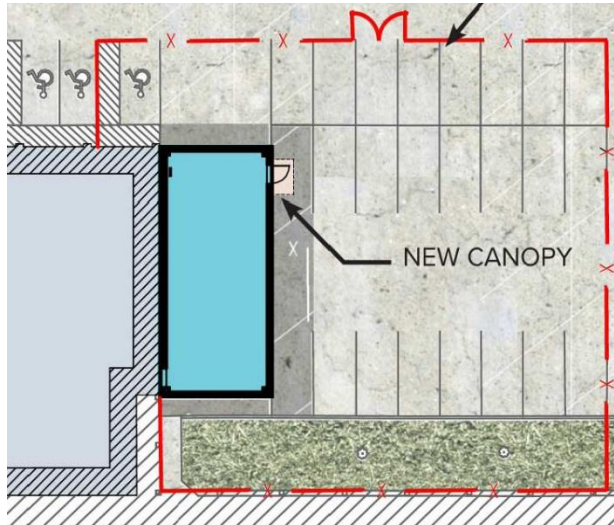

Lamar CHS New Rehearsal Hall

Terry High School

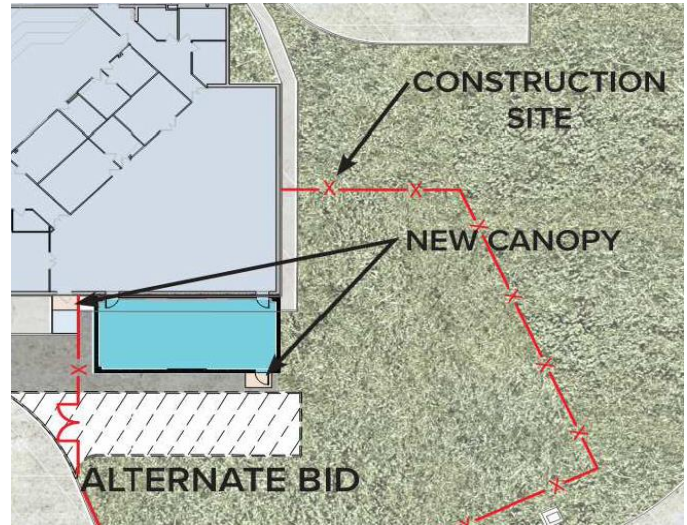

Terry HS New Rehearsal Hall

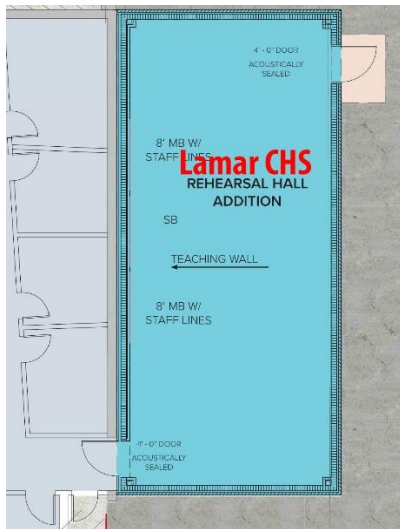

Lamar CHS New Rehearsal Hall

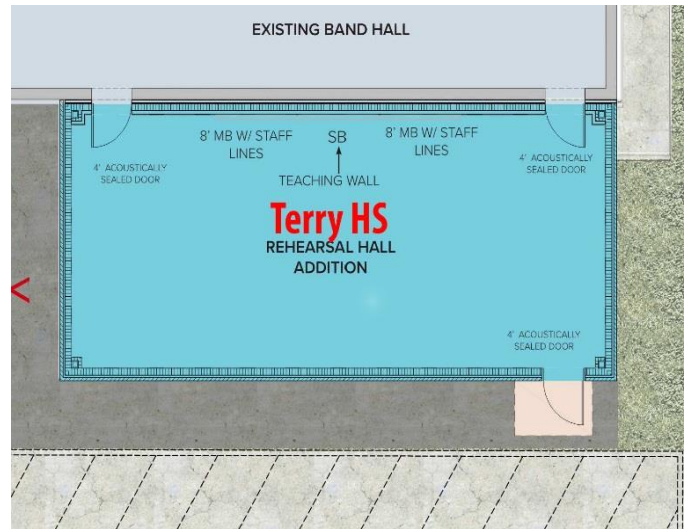

Terry HS New Rehearsal Hall

SCHEDULE MILESTONES

- Current Phase: Design Development
- Construction Start: 2nd Quarter 2017
- Construction Completion: 4th Quarter 2017

OVERVIEW

- Design Development for the new Rehearsal Hall Additions was approved by the Board in November 2016.

HUGGINS ELEMENTARY SCHOOL NEW PARENT DRIVE



SCHEDULE MILESTONES

- Current Phase: Construction
- Construction Completion: 1st Quarter 2017

OVERVIEW

- Phase 1 Construction: Construction of new faculty parking lot (53 parking spaces) is complete.
- Phase 2 Construction: Construction of new parent driveway underway, canopy and site lighting construction is currently in progress.
- Anticipated Completion by January 2017.

FOSTER HIGH SCHOOL WATER PLANT UPGRADES



SCHEDULE MILESTONES

- Current Phase: Design
- Construction Start: 2nd Quarter 2017
- Construction Completion: 4th Quarter 2017

OVERVIEW

- A new water well, new water storage tank and interconnecting piping and pumps are planned to provide additional water capacity on the 3-school site.
- Design phase has begun.
- Proposals for geotechnical studies and pollution hazard survey have been approved by the Board.

SATELLITE AG BARN #3

SCHEDULE MILESTONES

- Current Phase: Program Development
- Construction Start: Pending Site Selection

OVERVIEW

- A detailed program of requirements and building area requirements have been developed by the Architects following multiple meetings with the Building Committee.
 - Satellite Ag Barn #2 and #3 have been programmed together.
 - A site for the Satellite Ag Barn #3 has not been selected.
 - Project is on hold until a site has been identified.
-

HVAC WEB-BASED CONTROLS



OVERVIEW

- Design Development phase has been completed.
- The work will include replacing control systems to communicate to the District Maintenance staff over the internet, replacing the dial-up modems currently in use at 8 sites.

SCHEDULE MILESTONES

- Current Phase: Design
- Construction Start: 1st Quarter 2017
- Construction Completion: 3rd Quarter 2017

CHILLER REPLACEMENT



SCHEDULE MILESTONES

- Current Phase: Contract awarded
- Construction Start: 1st Quarter 2017
- Construction Completion: 2nd Quarter 2017

OVERVIEW

- LCISD Board awarded the Chiller Replacement project to American Mechanical Services.
- A pre-construction meeting has been set for mid-December.
- Work is scheduled to begin in January 2017.
- Six schools:
 - Alternative Learning Center
 - Frost Elementary School
 - Huggins Elementary School
 - Seguin Early Childhood Center
 - Travis Elementary School
 - Wessendorff Middle School

ACCESS CONTROLS



SCHEDULE MILESTONES

- Current Phase: Design
- Construction Start: 3rd Quarter 2017
- Construction Completion: 4th Quarter 2017

OVERVIEW

- Design has begun for the Districtwide Access Controls.
- Project is planned to provide a system to allow card access to all schools in the District.

FUTURE PROJECTS

OVERVIEW

- The future projects in the 2014 Bond Program will be reported on as they begin:
- **Bond Sale 2**
 - a. **Elementary #27**
 - b. **Elementary #28**
 - c. **Fulshear 6th Grade School**
 - d. **Fulshear Shell Space Build-Out**

COMPLETED PROJECTS

Foster High School Baseball Scoreboard Completed March 2016

INFORMATION ITEM: PROJECTS FUNDED BY 2011 AVAILABLE BOND FUNDS

The list below are projects that the Board has approved to move forward with 2011 available funds:

DISTRICT FENCE PROJECT:

CSP #37-2016ML was approved at the September 2016 Regular Board Meeting. A pre-construction meeting took place on September 29th at 1:00 p.m. The Anchor Group has submitted materials specifications which have been approved. The material has been ordered. Work will begin December 19th. Huggins and Bowie will be the first schools, followed by Meyer, Pink, Velasquez, Williams, and Beasley. Campbell, Hubenak and McNeill will be last due to lead time of material.

Project Budget \$450,000

CHILLER REPLACEMENT PROJECT:

VANIR Rice & Gardner are managing this project. Estes, McClure and Associates were approved at the September 2016 Regular Board Meeting. The materials specifications process has begun.

Project budget \$1,200,000

PARKING LOT LIGHTING RETROFIT:

VANIR Rice & Gardner have offered to manage this project and the amendment to their contract is on this month's agenda. KCI is currently preparing a set of specifications for the procurement process.

Project Budget \$1,600,000

HUGGINS PARKING AND PARENT DROPOFF:

VANIR Rice & Gardner are managing this project. Bass Construction has been progressing very well and on schedule. The canopy is installed and the drive is near completion.

Project Budget \$700,000

ACCESS CONTROL PROJECT:

VANIR Rice & Gardner are managing this project. KCI Technology has started the design process for the access control project.

Access Control Budget \$800,000

TERRY HIGH BASEBALL PROJECT:

This project is a 2014 Bond project managed by VANIR Rice & Gardner. At the August Board Meeting the Board of Trustees approved additional scope for this project and approved the additional funds to cover the project from the 2011 available funds. The bid process was delayed to solicit more bidders. Bids will be opened on December 14th.

Additional Budget of \$1,425,000

TOTAL BUDGET FOR AVAILABLE FUND PROJECTS = \$6,175,000

INFORMATION ITEM: TRANSPORTATION UPDATE

PERSONNEL CHANGES:

During the month of October, the following changes were made:

Trainees hired:	7
Drivers leaving the Dept.	1
Full time drivers hired:	2
Drivers waiting driving test	7
Bus aides hired:	1

Hiring Incentive Paid:	Employee	Referrer
Initial	2	2
Six months	2	0

ACCIDENTS:

The department had 4 on the road accidents in November.

Date	Bus #	Location	Act	Preventable
11/04/2016	417405	Foster	Tail swing hit a parked car	P
11/07/2016	408	90 and Oak Bend	Bus hit from rear	N
11/08/2016	107	FM1640	Hit fixed object	P
11/16/2016	417410	Houston Museum District	Tail swing hit guard rail	P

FIELD TRIPS:

Site	Number of Trips	Bus Miles	Sped Bus Miles	Truck Miles	White Fleet Miles
Rosenberg	314	20163	169	1976	0
Fulshear	138	7250	124	217	399

VEHICLE MAINTENANCE:

The Maintenance Department responded to a total of eight (8) breakdowns where the bus needed attention or replacement on the road.

Fuel Usage	Rosenberg	Fulshear
Diesel	29,182	13,576
Unleaded	6,303	346

ROUTING AND SCHEDULING:

We have the following routes in operation:

Track	AM / PM Routes	Mid-day Routes
Blue	29	4
Red	45	9
Gold	37	6
Maroon	46	8
Purple	15	4
Special Needs	38	30
Contracted with ALC	10 routes / 18 students	

We are still transporting 182 displaced students.

TRAINING AND OTHER EVENTS:

On November 8th, the Lamar CISD Fulshear Transportation Facility hosted the November meeting of the Gulf Coast Association for Transportation Chapter Meeting. Approximately 85 school transportation personnel and vendors attended the meeting from all around the Houston area. Dr. Randle gave the opening welcome, and the Terry ROTC color guard presented the colors and led the pledge to start the meeting. On November 16th and 17th, the Transportation Department held celebratory Thanksgiving lunches at the Rosenberg and Fulshear sites.

STUDENT DISCIPLINE:

A total of 277 discipline reports were issued in November.

Resource Persons: Kevin McKeever, Administrator for Operations
Mike Jones, Director of Transportation

INFORMATION ITEM: MAINTENANCE & OPERATIONS VEHICLE PURCHASES

Maintenance and Operations has purchased (2) Ford Transit Connect vans from Helfman Ford in the amount of \$39,576.

The staff requested pricing from multiple vendors that are on contract with purchasing cooperatives that Lamar CISD is a member. These vehicles will be used to accommodate the growth in the District in the daily operations by Maintenance and Operations staff.

Purchases from Helfman Ford are procured under the Fort Bend County Purchasing Interlocal Agreement, Contract 15-028. Authority for such procurements is granted under Government Code, Title 7, Chapter 791 Interlocal Cooperation Contracts, Subchapter B and Subchapter C, and Local Government Code, Title 8, Chapter 271, Subchapter F, Section 271.101 and Section 271.102.

Submitted by: Kevin McKeever, Administrator for Operations
Aaron Morgan, Director of Maintenance
Michele Leach, Purchasing & Materials Manager