

SUMMARY OF THE WORK

PART 1 - GENERAL

1.01

1. The furnishing of all labor, materials, equipment, services, and transportation of Rosemont Middle School PE Coaches HVAC at 4725 Rosemont Ave, La Crescenta, CA 91214 Documents which is required for the completion of the project in accordance with the provisions of the contract
2. Article 3 of the Bid General Conditions requires preparation of a Cost-loaded time logic schedule with a single critical path. If the Board approved lowest responsive and responsible bid Contractor and the Project Manager, on behalf of the District, cannot agree on the contract construction schedule and the project single critical path within fifteen (15) days after Notice to Proceed, the District may terminate the Contract, for convenience, as outlined in the Project General Conditions. In the event this is necessary, compensation to the General Contractor and all subcontractors or materialmen shall be limited to Mobilization costs only.
3. The liquidated damages shown in the Supplementary General Conditions shall apply to each phase of the phased construction plan, as defined by and within the plans and specifications.
4. No warranties or guarantees shall go into effect, for any trade, regardless of when completed in the sequence of the project erection, until one (1) day after the Board of Education has accepted the project at a noticed meeting. Attention: Bidders. This will require certain trades to bid for, and provide, a warranty of longer than one (1) year in length from the time of installation or furnishing of their materials to the project, depending upon the sequencing of their work within the overall schedule.
5. All project close-out/punch list items, project record documents, submittals, and operations manuals and spare parts, warranties and guarantees and Contractor's Final Verified Report (DSA6) shall be reviewed and accepted prior to the Architect/District agreed upon authorization to file the Notice of Completion with the Los Angeles County Recorder.
6. In the event that any materials requiring DSA Inspection (steel, concrete, masonry grout, etc.) are manufactured in an area located more than one hundred miles (100 miles) by air radius from the project site, all round-trip travel and all per diem costs incurred by the District on behalf of the Deputy Inspector who must perform on-site examination of the materials shall be borne 100% by the Contractor as an added expense. This charge shall be subtracted from the monthly "Application for Payment" submitted to the District on behalf of the project.
7. In the event the General Contractor or any subcontractor or materialman (on or off site) voluntarily accelerates the schedule for their own purposes, and/or voluntarily performs work in excess of eight (8) hours per day, or on the weekends or holidays, the additional cost of the Inspectors' overtime premiums which are required to inspect the work during these hours shall be paid 100% by the Contractor. This charge shall also be subtracted from the monthly "Application for Payment" submitted to the District on behalf of the project.
8. In the event that the Contractor fails to complete all punch list items and turn over all "deliverables, warranties, As-builts, etc." within sixty (60) days after acceptance of completion by the Board of Education, the full salary costs of one (1) construction Project Manager (16 hours per week @ \$120.00/hour) and one DSA Inspector of record (actual hours spent @\$80.00/hour) shall be back-charged to the Contractor, in addition to the liquidated damages, if any, imposed upon the Contractor for late performance. THIS PARAGRAPH WILL BE STRICTLY ENFORCED.
9. The intent of these contract documents is that the work of alteration, rehabilitation or construction

is to

as

deterioration or non-complying construction be discovered which is not covered by the Contract Documents wherein the finished work will not comply with Title 24, California Code of Regulations,

a

change order, or a separate set of plans and specifications, detailing and specifying the required repair work shall be submitted to and approved by DSA before proceeding with the repair work.

a.

RELATED SECTIONS

PART 2 – SCOPE OF WORK

2.01

A. Scope of Work: Contractor shall perform, within the time stipulated, the Contract including all of its component parts, and everything required to be performed, and to provide and furnish any and all of the labor, materials, tools, expendable equipment, and all applicable taxes, and all utility and transportation services necessary to perform the Contract and complete, in a workmanlike manner, all of the Work required in connection with the following titled Project in strict conformity with the Contract Documents:

2.02

A. Rosemont Middle School at 4725 Rosemont Ave, La Crescenta, CA 91214

- A. Installation of HVAC units in Boys and Girls Coaches office with a main 200 amp panel on the roof.
1. All ac units and other materials must be provided by contractor.
 2. All electrical materials is to be provided by contractor
 3. Contractor is to provide an outdoor commercial rated 200 amp Panel on the roof from existing main Panel room (Contractor is to estimate how long the run is based on the best path of travel from the electrical room to the location)
 4. If no 208-230 Power is available, contractor is to provide a Transformer to bring down the Voltage to 208-240V. three phase to 208-230, 3 phase
 5. Contractor is responsible for the breaker, connections, wires and other materials needed for the electrical work including coring of the wall
 6. Install 1 new Carrier Model Number RAV-SP420UT-UL indoor coil and a RAV-SP420AT2-UL with all of the necessary refrigeration lines,, electrical connections, and plumbing connections with all necessary hardware to be provided by contractor for each (boys and Girls totaling 2 units)
 7. Install disconnects for indoor units for serviceability.
 8. Install all high and low voltage necessary electrical for each unit indoor and outdoor Provide new hard wired thermostat with wiring for HVAC units with new thermostats (no remote control options Please)
 9. Brace all of the indoor / outdoor evaporator and condensing units to supports to wall and on roof with absorption isolating mounts. (contractor must provide new prefabricated curb and attach it to the roof and secure condensers on top
 10. Name and Tag every unit with ID badges indoor on roof and indoor unit with all room numbers and breaker number
 11. Provide new disconnects on roof with id tags with Square D nema 3 outdoor rated disconnect boxes
 12. Contractor is responsible for all low and high voltage electrical and communication wires from indoor to outdoor unit.
 13. Pressure test all lines to make sure there are no leaks in the line sets..
 14. Install new copper condensate drain lines with traps and make sure drain lines for condensation is clear
 15. Contractor is responsible of all clean up and disposal of items resulting from work including all refrigerant.
 16. Contractor is responsible to do all of ceiling tile modifications and any other modifications for indoor units

17. Contractor is responsible for any coring making sure to coordinate with district roofer or Tremco Representative for proper Tremco Materials (note all roofing materials must be Tremco due to a 20 year warranty)
18. Contractor is responsible for any cranes and setting of units in room and on rooftop.
19. Contractor is responsible for all roof patching if necessary (must use Tremco certified roofer)
20. Contractor is to provide their own disposal and are not allowed to use district trash bins
21. Contractor is responsible for moving all furniture in room and relocating back to original location
22. Must clean entire work area and job site and have ready for occupancy.



SUBMITTAL

Project

Rosemont MS GUSD Coach Office

Date

Thursday, July 05, 2018

Table Of Contents

Project: Rosemont MS GUSD Coach Office

07/05/2018

Untitled1	3
Unit Report	4
Certified Drawing	5
Performance Summary	8

Untitled1 Tag Cover

Sheet
**Unit Report
Certified Drawing
Performance Report**

Unit Report For Untitled1

Project: Rosemont MS GUSD Coach Office

07/05/201



System Parameter

System Quantity: _____ **1**
Refrigerant Type: _____ **R-410A**
Compressor Type: _____ **Inverter Driven**
Std. Min. Outdoor Temp(Cooling): _____ **-13.0 F**
Std. Max Outdoor Temp (Cooling): _____ **122 F**

Indoor Unit Parameters

Unit Quantity: _____ **1**
Unit Model: _____ **40MAQB36B--3**
Unit Size: _____ **36,000 Btuh**
Voltage: _____ **208/230-1-60** V-Ph-Hz

Outdoor Unit Parameters

Unit Quantity: _____ **1**
Unit Model: _____ **38MAQB36R--3**
Unit Description: _____ **DLS 36K 230V HP CDU**
Unit Size: _____ **36,000 Btuh**
Voltage: _____ **208/230-1-60** V-Ph-Hz

Indoor Unit 1 Dimensions and Weight

Unit Model: _____ **40MAQB36B--3**
Unit Length: _____ **10"**
Unit Width: _____ **3' 11"**
Unit Height: _____ **1' 1"**
Unit Operating Weight: _____ **40**
lb

Outdoor Unit Dimensions and Weight

Unit Model: _____ **38MAQB36R--3**
Unit Length: _____ **1' 4"**
Unit Width: _____ **3' 1"**
Unit Height: _____ **2' 8"**
Unit Operating Weight: _____ **147** lb

Warranty Information

NOTE: Please see Warranty Card for explanation of policies.
LIMITED WARRANTY*

– 10 year limited to original purchaser on compressor and parts upon timely registration, otherwise 5 years

*For residential applications. See warranty for full details.

Ordering Information

Part Number	Description	Quantity
Base Unit - Indoor		
40MAQB36B--3		1
Outdoor Unit		
38MAQB36R--3	DLS 36K 230V HP CDU	1

Certified Drawing for Untitled1

Project: Rosemont MS GUSD Coach Office

07/05/2018

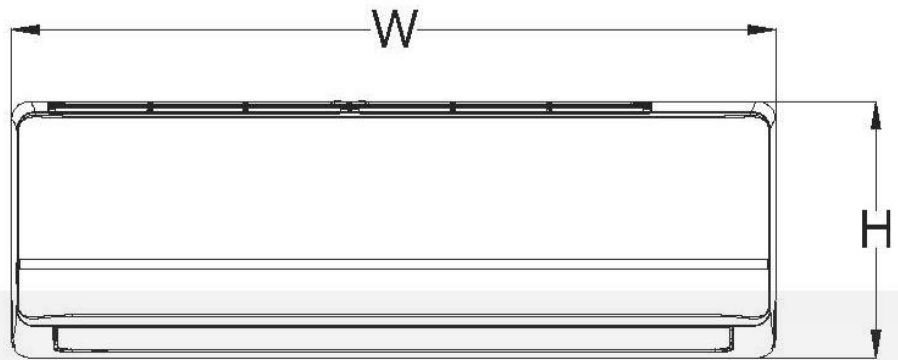
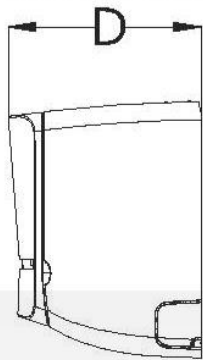
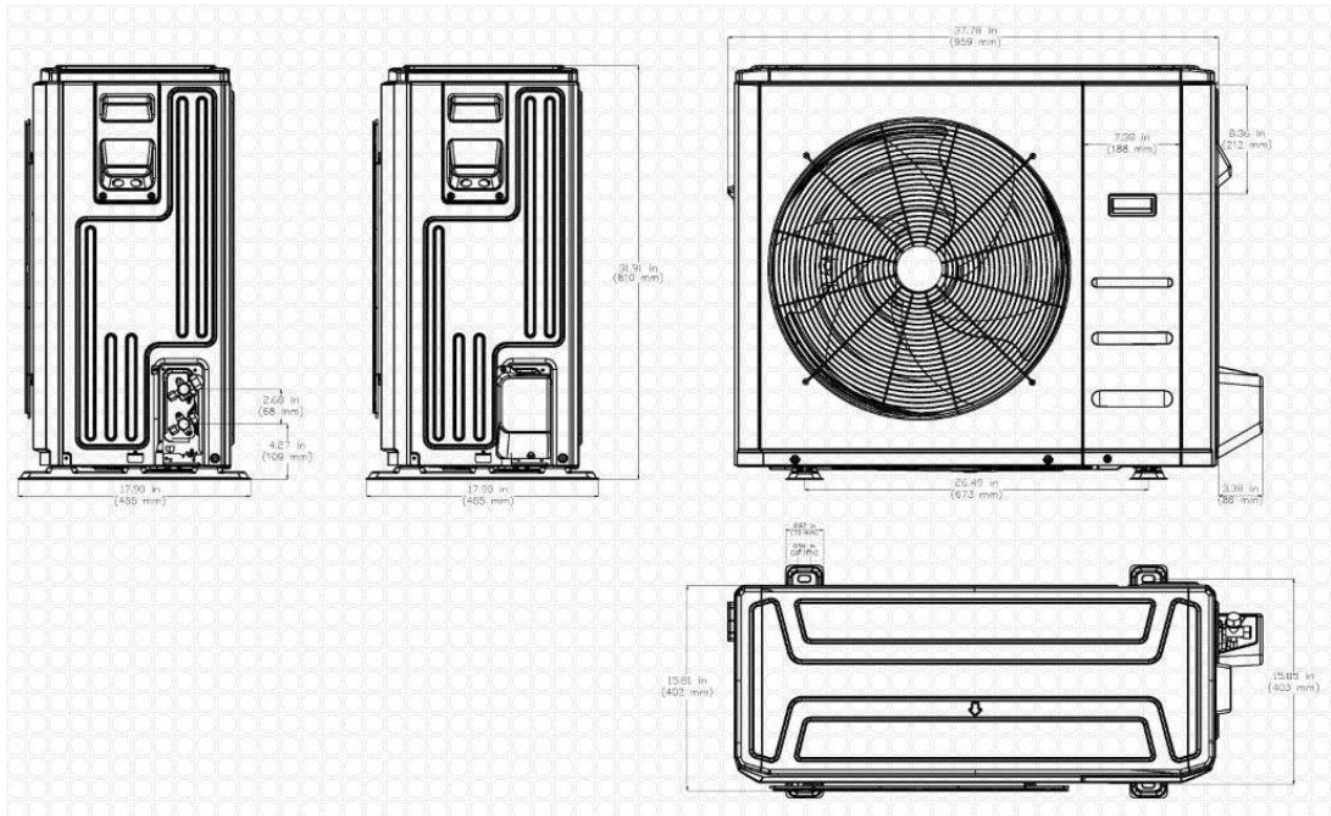

Model	W in(mm)	D in(mm)	H in(mm)
9K	32.87(835)	7.80(198)	11.02(280)
12K	32.87(835)	7.80(198)	11.02(280)
18K	38.98(990)	8.58(218)	12.40(315)
24K	46.69(1186)	10.16(258)	13.39(343)
30K & 36K	46.69(1186)	10.16(258)	13.39(343)

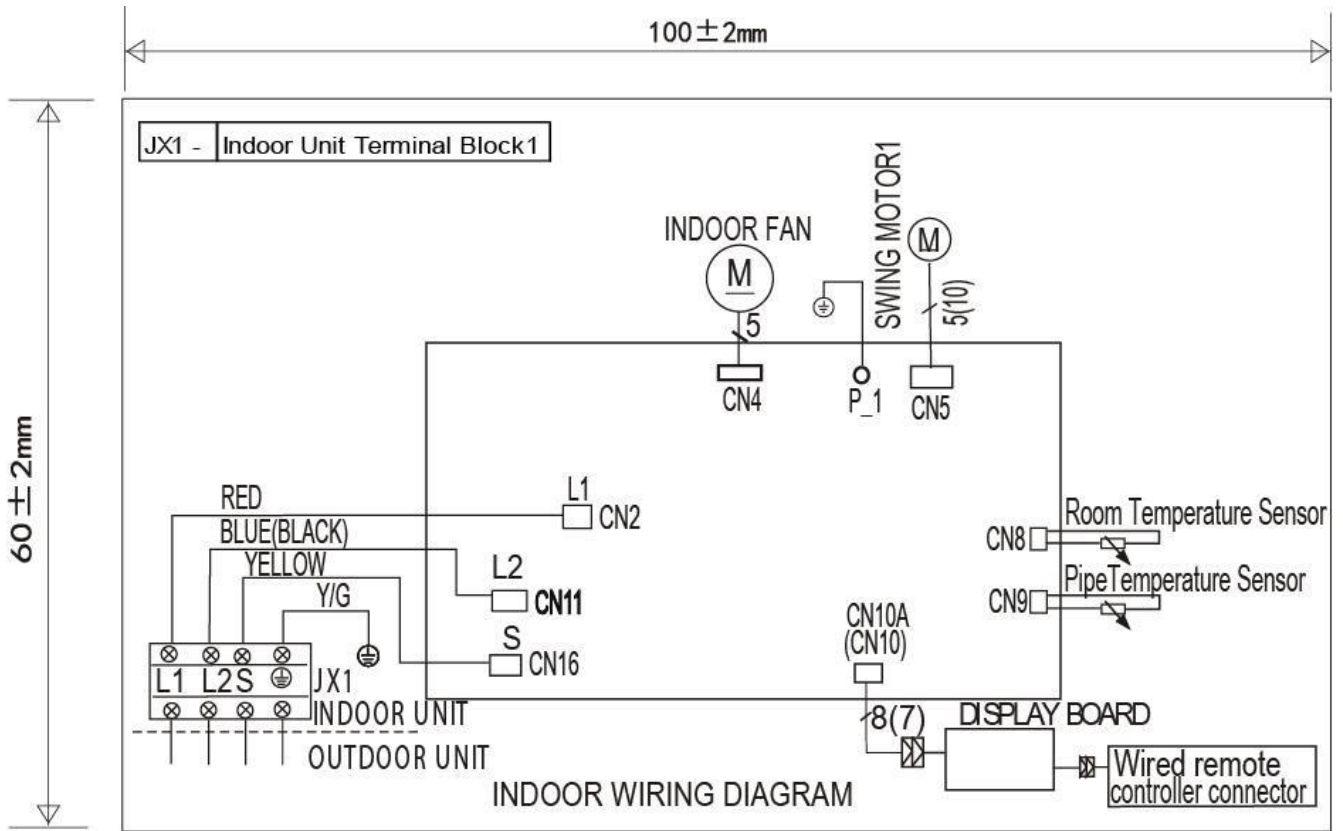

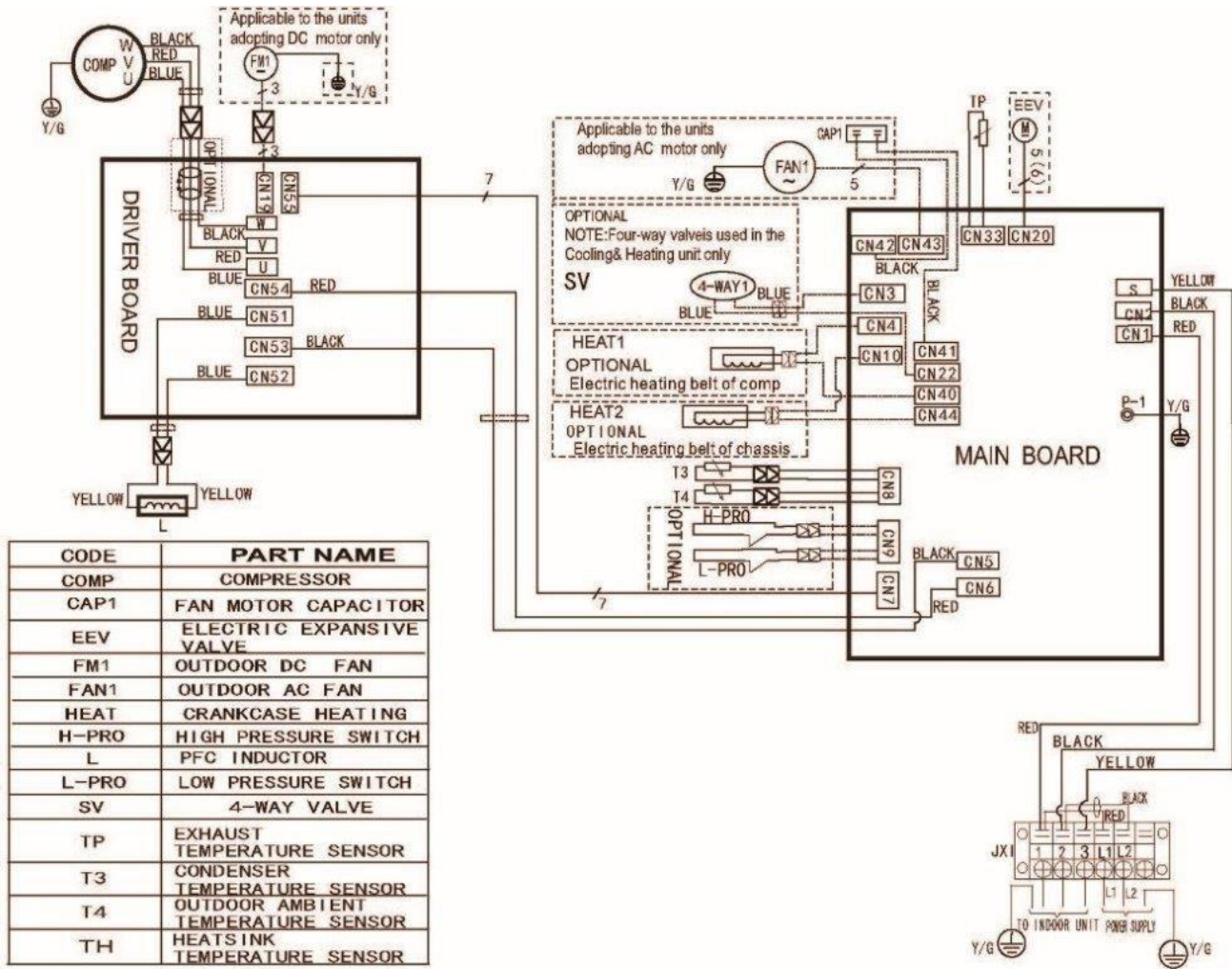

Performance Summary For Untitled1

Project: Rosemont MS GUSD Coach Office

07/05/2018

System

Outdoor Unit: 38MAQB36R--3
Indoor Unit: 40MAQB36B--3
System Quantity: 1
Altitude: 0.0 ft
Linear Pipe Length: 20.0
ft Long Line Charge: 0.0
oz.
Vertical Lift: 0.0 ft
Suction Line Size: 5/8
in. Liquid (Mixed Phase) Line Size: 3/8
in.

System Performance

Rated Cooling Capacity: 36000.0 BTU/hr
Cooling Capacity Range: 8000-36200 BTU/hr
Rated Heating Capacity: 36000.0 BTU/hr
Heated Capacity Range: 9000-37000 BTU/hr
SEER: 16.0
EER: 8.6
HSPF: 8.5
High Temp COP: 2.56

Indoor Acoustics

Model: 40MAQB36B--3
Airflow Low: 520.0 CFM
Airflow Medium: 620.0 CFM
Airflow High: 780.0 CFM
Airflow Turbo: 870.0 CFM
Clg Sound Press. Low: 39.0 dB
Clg Sound Press. Medium: 45.0 dB
Clg Sound Press. High: 50.0 dB
Htg Sound Press. Low: 38.0 dB
Htg Sound Press. Medium: 44.0
dB Htg Sound Press. High: 47.0
dB

Outdoor Acoustics

Outdoor Clg Sound Pressure: 61.0 dB
Outdoor Htg Sound Pressure: 61.0 dB
Airflow: 2130 CFM

Electrical Data Indoor Unit 1

Model: 40MAQB36B--3
Indoor MCA: NA Amps
Indoor MOCP: NA
Amps Fan Motor FLA: 0.23
Amps Powered From Outdoor: Yes

Electrical Data Outdoor Unit

Outdoor Unit Voltage: 208/230-1-60 V-Ph-Hz
Outdoor Voltage Range Min: 187 V
Outdoor Voltage Range Max: 253 V
Outdoor MCA: 25.0
Amps Outdoor MOCP: 35.0
Amps Compressor RLA: 17.00

Performance Summary For Untitled1

Project: Rosemont MS GUSD Coach Office

07/05/2018

Amps Compressor LRA:
Amps

NA

System Operating

Envelope Cooling

Max Outdoor DB:	_____	122.0	F
Min Outdoor DB:	_____	-13.0	F
Max Indoor DB:	_____	90.0	F
Max Indoor WB:	_____	84.0	F

Min Indoor DB: _____ **63.0** F Min
Indoor WB: _____ **59.0** F
Heating
Max Outdoor DB: _____ **86.0** F Min
Outdoor DB: _____ **-13.0** F Max
Indoor DB: _____ **86.0** F Min
Indoor DB: _____ **32.0** F

SECTION 01730

DEMOLITION PROCEDURES

PART 5 - GENERAL

1.01 SECTION INCLUDES

- A. General requirements for special project procedures pertaining to the alteration or modification of existing construction, and are complimentary to like requirements indicated or specified elsewhere. Principals items included are:
 - 1. Removals, cutting, alterations and repairs to existing facilities as required to complete work.
 - 2. Relocation and reinstallation of existing construction and finish.
 - 3. Salvage, storage and protection of existing items to be reinstalled.
 - 4. Salvage and delivery to the District of items so designated for removal and salvaged by Contractor, as directed.

1.02 RELATED SECTIONS

- A. Requirements of other Sections of this Specification apply to this Section.

1.03 PROPERTY INVENTORY

- A. District property that the District intends to remove, will be removed at no cost to Contractor, before a room or space is vacated for the Work. Before performing any Work in each room or space the District and Contractor shall prepare a detailed initial written inventory of District property remaining therein and condition thereof including equipment and telephone instruments, and each shall retain a copy of the inventory dated and signed by both. In same manner, prior to the District re-occupancy of each such room or space the parties shall again inventory District property therein and all discrepancies between the inventories shall be Contractor's responsibility as specified above.

1.05 JOB CONDITIONS

- A. General: Coordinate the Work of all trades and with the District to assure correct sequence, limits, methods, and times of performance. Arrange the Work to impose minimum hardship on operation and use of the facilities. Install protection for existing facilities, contents, and new work against dust, dirt, weather, damage, and vandalism, and maintain and relocate as the Work progresses.
- B. Access: Confine entrance and exit operations to access routes designated by the District.
- C. Existing Conditions: Intent of Drawings is to indicate existing site and facility conditions with information developed from original construction documents, field surveys, and the District records, and to generally indicate amount and type of demolition and removals required to prepare existing areas for new work.

- D. Verification of Conditions: Perform a detailed survey of existing site and building conditions pertaining of the Work before starting Work. Report to the District Inspector discrepancies or conflicts between Drawings and actual conditions in writing for clarification and instructions and do not perform Work where such discrepancies or conflicts occur prior to receipt of the Architect's instructions.
- E. Special Noise Restrictions: Use care to prevent generation of unnecessary noise and keep noise levels to minimum possible. When ordered by the District Inspector, immediately discontinue such methods that produce noise disruptive or harmful to facility functions and occupants, and employ unobjectionable methods. Equip air compressors, tractors, cranes, hoists, vehicles, and other internal combustion engine equipment with "residential" grade mufflers, and muffle the unloading cycle of compressors. Remove from site any equipment producing objectionable noise as determined by the District Inspector.
- F. Shoring and Bracing: Provide supports, shoring, and bracing required to preserve structural integrity and prevent collapse of existing construction that is cut into or altered as a part of the Work.
- G. Overloading: Do not overload any part of structures beyond safe carrying capacity by placing of materials, equipment, tools, machinery, or any other item thereon.
- H. Building Security: Secure building entrances and exits with locking or other approved method in accordance with the District's instructions.
- I. Safeguarding the District Property: Contractor shall assume care, custody, and responsibility for safeguarding all the District's property of every kind, whether fixed or portable, remaining in rooms and spaces vacated and turned over to the Contractor by the District for his exclusive use in performance of the Work until the Work therein or related thereto is completed and the rooms or spaces are reoccupied by the District. Furnish all forms of security and protection necessary to protect the District's property. Regardless of cause, Contractor shall repair or replace all of the District's property under the Contractor's care, custody, and safeguarding that is damaged, injured, missing, lost, or stolen from time each such room or space is turned over the Contractor for the Work until re-occupied by the District, at Contractor's expense and as directed by the District.
 - 1. Covering and Cleaning: Cover and protect surfaces of rooms and spaces turned over for the Work, including the District's property remaining therein, as required to prevent soiling or damage by dust, dirt, water, fumes, or otherwise, and protect other areas where Work is performed in same manner, as deemed adequate by the District. Prior to District's re-occupancy of any such room or space, clean all surfaces including District's property in accordance with General Conditions and other cleaning instructions as may be specified in other Sections.
- J. Use of District's Telephones: Do not use nor allow anyone other than District employees to use telephone in rooms and spaces turned over to Contractor for the Work except in the case of a bona fide emergency. Install temporary dial locks on telephone instruments to prevent all unauthorized use, or arrange and pay for temporary removal and reinstallation of instruments. Reimburse to the District all telephone toll charges originating from the telephones in such rooms and spaces except those arising from emergencies or use by District employees.
- K. Welding: Conform to following requirements where welding is performed in or on existing facilities.
 - 1. Protection During Welding: Conform to Title 8, CAC. Further protect occupants and the public with portable solid vision barricades around locations where welding is performed plus signs warning against looking at welding without proper eye protection, or equivalent.
 - 2. Fire Extinguishers: Maintain a fully charged UL-labeled minimum 6 pound 40B:C dry chemical fire extinguisher at every location where welding is performed within or on the facilities.
 - 3. Welding Smoke Control: Verify locations of existing smoke detectors. Perform welding operations by methods that produce the minimum feasible smoke and fumes. Furnish portable type smoke collection and ventilating equipment as required to prevent smoke and fume nuisances. Notify District at least 48 hours in advance if temporary deactivation of any smoke detector is required to prevent false alarms from the welding operations. The District's personnel will deactivate detectors only for the time welding is actually in progress.

4. Fire Prevention: Before welding, examine existing construction and backing for all combustible materials and finishes and for conditions where heat conduction in metals may bring adjoining materials to ignition temperature. Use positive fire prevention measures including temporary removal and reinstallation of combustible materials, installation of temporary shields and/or heat sinks, and other necessary means. When actual field conditions are such that positive fire prevention measures cannot be achieved, notify Architect and do not proceed with the involved work until receipt of Architect's instructions.

L. Protection of Floors: Use care to protect all floor surfaces and coverings from damage. Equip mobile equipment with pneumatic tires.

PART 2 - PRODUCTS

2.01 MATERIALS:

A. General: When patching existing work in place, use materials that match existing materials in performance, thickness and finish.

PART 3 - EXECUTION

3.01 PROTECTION:

A. Glass: Provide such protection as may be required to prevent glass breakage for all glass to be reused or to remain. At no additional cost, replace in kind all broken glass.

B. Existing Work to Remain: Provide such forms of protection as may be necessary to prevent damage to and dust or dirt contamination of existing work and equipment to remain.

C. Items to be Reused: Exercise the greatest possible care when removing items scheduled for reuse. Use only mechanics skilled in the appropriate trades. Identify point of reuse, store and protect at locations directed.

D. If required due to damage, replace with new materials to match existing in same manner and technique originally utilized.

3.02 REMOVALS, ALTERATIONS, AND REPAIRS:

A. Basic Requirement: Restore and refinish all new and existing construction and improvements that are cut into, altered, damaged, relocated, reinstalled, or left unfinished by removals to original condition or to match adjoining work and finishes unless otherwise shown, specified, directed, or required. Workmanship and materials shall conform to applicable provisions of other Sections. Provide new fasteners, connectors, adhesives, and other accessory materials as required to fully complete approved reinstallations and restorations. Where restorations and refinishing are defective or are otherwise not acceptable to Architect, remove all the defective or rejected materials and provide new acceptable materials and finish at no extra cost to District.

B. Extent: Perform removals to extent required plus such additional removals as are necessary for completion even though not indicated or specified. More or less of the existing construction may be removed if such variation will expedite the work and reduce cost to the District, subject to prior approval in each case.

C. Removals: Carefully remove work to be salvaged or reinstalled and store under cover.

3.03 MECHANICAL AND ELECTRICAL:

A. Demolish existing mechanical, plumbing and electrical items as indicated in the Drawings and Specifications.

3.04 REMOVED MATERIAL AND DEBRIS:

A. All removed material, not otherwise designated, and all debris becomes the property of the Contractor who shall remove it from the site and dispose of it in a legal manner.

B. Do not allow materials and debris generated by demolition activities to accumulate. Remove daily.

- C. Leave all spaces broom clean with all ledges and corners properly cleaned.

END OF SECTION

SECTION 23 05 00

COMMON WORK RESULTS FOR HVAC

PART 1 GENERAL

1.01 RELATED DOCUMENTS

- A. Drawings and general provisions of Contract, including General and Supplementary Conditions and Division 01 Specification Sections, apply to this and the other sections of Division 22.
- B. This Division is an integrated whole comprising interrelated and interdependent Section and shall be considered in its entirety in determining requirements of the Work.
- C. Refer to other sections of this Division for additional requirements or information regarding the subjects of this Section.

1.02 SECTION INCLUDES

- A. This Section includes general administrative and procedural requirements for mechanical installations. The following administrative and procedural requirements are included in this Section to expand the requirements specified in Division 01:
 - 1. Submittals.
 - 2. Coordination drawings.
 - 3. Record documents.
 - 4. Maintenance manuals.
 - 5. Rough-ins.
 - 6. Plumbing installations.
 - 7. Cutting and patching.

1.03 DESCRIPTION

- A. Provide a complete and operable installation, including all labor, supervision, materials, equipment, tools, apparatus, transportation, warehousing, rigging, scaffolding and other equipment and services necessary to accomplish the work in accordance with the intent and meaning of these drawings and specifications

1.04 DEFINITIONS

- A. "Provide" means furnish, install and connect unless otherwise described in specific instances. B. "Piping" means pipes, fittings, valves and all like pipe accessories connected thereto.
- C. "Ductwork" means ducts, plenums, compartments, or casings including the building structure, which are used to convey or contain air.
- D. "Extend", "Submit", "Repair" and similar words mean that the Contractor (or his designated subcontractor) shall accomplish the action described.
- E. "Codes" or "Code" means all codes, laws, statutes, rules, regulations, ordinances, orders, decrees, and other requirements of all legally constituted authorities and public utility franchise holders having jurisdiction.
- F. "Products", "Materials" and "Equipment" are used interchangeably and mean materials, fixtures, equipment, accessories, etc.
- G. "Utility Areas" are defined as mechanical, electrical, janitorial, and similar rooms or spaces which are normally used or occupied only by custodial or maintenance personnel. "Public Areas" are defined as the rooms or spaces, which are not included in the utility areas definition.
- H. "Building Boundary" includes concrete walkways immediately adjacent to the building structure.

- I. "Below Grade" means buried in the ground.
- J. "Substantial Mechanical Completion" means all components of all systems are functioning but lacking in final adjustment.
- K. Pressure rating specified (such as for valves and the like) means design working pressure for and with references to the fluid, which the device will serve.

1.05 RELATED WORK

- A. Coordination: Refer to Architectural, Civil, Structural, and Electrical Drawings for the construction details and coordinate the work of this Division with that of other Divisions. Order the work of this Division so that progress will harmonize with that of other Divisions and all work will proceed expeditiously. The work of this Division shall include direct responsibility for the correct placing and connection of mechanical work in relation to the work of other Divisions.
- B. Examine other Divisions for work related to the Work of this Division, especially Electrical.

1.06 EXISTING CONDITIONS

- A. Visit the site prior to bidding and investigate the existing conditions, which affect or will be affected by the work of this Division. Become thoroughly familiar with the working conditions and take into account any special or unusual features peculiar to this job. By the act of submitting a Bid, the Contractor will be deemed to have complied with the foregoing, to have accepted such conditions, and to have made allowance therefore in preparing his Bid.
- B. The locations of existing concealed utility lines are shown in accordance with reference data received by the Architect. The Architect does not guarantee the accuracy of such data. The points of connection are therefore approximate and the Bidder shall include adequate funds in his Bid to cover costs of connection regardless of their exact location.
- C. Exercise extreme caution during trenching operations. Repair the damage caused by such operations to existing utility lines at no cost to the Owner, whether the lines are shown on drawings or not.

1.07 DRAWINGS AND SPECIFICATIONS

- A. These drawings and specifications do not include necessary components for construction safety. B. All provisions shall be deemed mandatory except as expressly indicated as optional by the word "may" or "option".
- C. Except where dimensioned, the drawings relating to this division are a diagrammatic presentation of the design concept, which indicates the general area where piping and ductwork is to be run. The drawings do not necessarily indicate any and all offsets and configurations required for coordination with other trades. The contractor is responsible for the correct placing of his work, and the proper location and connection of his work in relation to the work of other trades.

1.08 PERMITS AND INSPECTIONS

- A. Obtain, schedule and pay for permits, licenses, approvals, tests, and inspections required by legally constituted authorities and public utility franchise holders having jurisdiction over the work.
- B. Afford the Architect's representative every facility for evaluating the skill and competence of the mechanics and to examine the materials. Concealed work shall be reopened when so directed during his periodic visits.

1.09 CODES AND REGULATIONS

- A. By submitting a Bid, Contractor is deemed to represent himself as competent to accomplish the work of this Division in conformance with applicable Codes. In case of conflict between the Contract Documents and Code requirements, the Codes shall take precedence. Should such

conflicts appear, cease work on the parts of the contract affected and immediately notify the Architect in writing. It shall be the Contractor's responsibility to correct, at no cost to the Owner, any work he executes in violation of Code requirements. Specific references to codes elsewhere in this Division are either to aid the Contractor in locating applicable information or to deny him permission to use options, which are permitted by Codes.

- B. Applicable Codes: (Current editions unless otherwise noted)
 1. All local codes; city and/or county as applicable.
 2. OSHA requirements
 3. California Code of Regulations (CCR) Titles (as applicable)
 4. Fire Marshal Regulations
 5. State, County, City Health Department Ordinances and Regulations
 6. Regulations of all other authorities having jurisdiction.
 7. California Mechanical Code.
 8. California Plumbing Code.
- C. Where conflict or variation exists amongst Codes, the most stringent shall govern.

1.10 SUBMITTALS

- A. General: Follow the procedures specified in Division 01.
- B. Mechanical Submittals: Increase the number of mechanical related shop drawings, product data, and samples submitted to allow for required distribution by one additional copy, which will be retained by the Mechanical Consulting Engineer.
- C. Product Data: Assemble "product data" into tabbed brochures according to main areas of work i.e. Fire Protection; Plumbing; H.V.A.C.; Temperature Control; Testing, Adjusting, and Balancing.
 1. Assemble each brochure with tabbed separators for each Specification Section where products are noted to be submitted, with separate tabs for each product listed.
 2. Temperature "control shop drawings" may be submitted separately after preparations for review.
 3. For items such as valves, hangers and accessories, indicate specific items and where they are to be used.
 4. Contractor need only to submit for review those items specified to be submitted, unless requested by the Architect for special review.
- D. Submit for review, only the specific items required in this Section or other Sections of Division 22. E. Additional submittals shall include, but not limited:
 1. Air balance reports and equipment data record drawings.
 2. Certification of completion of testing.
 3. Certification of completion of operation instructions.
 4. Operating instruction brochure.
 5. Maintenance instruction brochures.
 6. Equipment guarantees.
 7. 1/4" = 1'-0" or larger scale layouts of "Equivalent" equipment or "Or Approved Equal" equipment.
 8. Coordination Drawings, where requested or required.
- F. Submittal materials will be reviewed for substantial conformity with the intent of the contract plans and specifications only. Such review does not indicate approval of dimensions, quantities, coordination with other trades, or work methods of the contractor, which are indicated thereon.
- G. Additional copies may be required by individual sections of these specifications.

1.11 COORDINATION

- A. The Contractor shall be responsible for coordinating the layout of all building elements to avoid conflict of the work of the structural, mechanical, electrical systems, and architectural features of the building.
- B. The cost of any extra work of any kind caused by a conflict due to this lack of coordination shall be borne by the Contractor.
- C. Contractor shall designate an individual competent and versed in the mechanical trades to coordinate the mechanical work with the work of other trades.

1.12 COORDINATION OF DRAWINGS

- A. Prepare coordination drawings in accordance with Division 01 to a scale of 1/4" = 1'-0" or larger; detailing major elements, components, and systems of mechanical equipment and materials in relationship with other systems, installations, and building components. Indicate locations where space is limited for installation and access and where sequencing and coordination of the installations are of importance to the efficient flow of the Work, including but not necessarily limited to the following:
 - 1. Indicate the proposed locations of piping, ductwork, equipment, and materials. Include the following:
 - a. Clearances for servicing and maintaining equipment, including tube removal, filter removal, and space for equipment disassembly required for periodic maintenance.
 - b. Equipment for connections and support details.
 - 2. Prepare reflected ceiling plans to coordinate and integrate installations, air outlets and inlets, light fixtures, communication systems components, sprinklers, and other ceiling-mounted items.
- B. Submittal of "Or Approved Equal" substitutions of equipment will not be reviewed unless accompanied by coordination drawings.

1.13 RECORD AND DOCUMENTATION

- A. Prepare record documents in accordance with the requirements in Division 01. In addition to the requirements specified in Division 01, indicate the following installed conditions:
 - 1. Record as specified in Division 01 the locations and invert elevations of underground installations.
 - 2. Accumulate the following and deliver to the Owner's representative prior to final acceptance of the work.
 - 3. Record (As-Built) Drawings:
 - a. Maintain in good order in the field office a complete set of prints for all work being done under Division 23. Update the drawings daily with neat and legible annotations in red ink showing the work as actually installed.
 - b. The actual size, location and elevation of all buried lines, valve boxes, manholes, monuments, and stub-outs shall be accurately located and dimensioned from building walls or other permanent landmarks.
 - c. Furnish the originals.
 - 4. Operation and Maintenance Manual: Furnish an operation and maintenance manual covering the stipulated mechanical systems and equipment. Three copies of the manual, bound in hardback binders or an approved equivalent shall be provided to the Architect.
 - 5. Furnish one complete manual prior to the time that system or equipment tests are performed.
 - 6. Furnish the remaining manuals before the contract is completed.
 - 7. The following identification shall be inscribed on the cover: OPERATION
AND MAINTENANCE MANUAL PROJECT TITLE
CONTRACTOR
 - 8. Provide a table of contents. Insert tab sheets to identify discrete subjects. Instruction sheets shall be legible and easily understood, with large sheets of drawings folded in. The manual

shall be complete in all respects for all materials, piping, valves, devices and equipment, controls, accessories and appurtenances stipulated. Include as a minimum the following:

- a. Updated approved materials lists, shop drawings and catalog information of all items of mechanical system equipment.
- b. System layout showing piping, valves and controls.
- c. Wiring and control diagrams with data to explain detailed operation and control of each component.
- d. A control sequence describing start-up, operation and shutdown.
- e. Detailed description of the function of each principal component of the system. f. Procedure for starting.
- g. Procedure for operating. h. Shut-down instructions.
- i. Installation instructions.
- j. Adjustments, maintenance and overhaul instructions.
- k. Lubrication schedule including type, grade, temperature range and frequency. l. Safety precautions, diagrams and illustrations.
- m. Test procedures.
- n. Performance data.
- o. Parts list, with manufacturer's names and catalog numbers. p. Preventive maintenance schedule.
- q. Service organization with name, address and telephone number. r. Valve identification chart and schedule.
- s. ASME certificates.
- t. Air balance report.
- u. Hydronic balance report.

- B. Standards Compliance: Where equipment or materials are specified to conform with requirements of standards of recognized technical or industrial organizations such as American National Standards Institute (ANSI) American Society for Mechanical Engineers (ASME) American Society of Heating, Refrigeration and Air Conditioning Engineers (ASHRAE), American Society for Testing and Materials (ASTM), Underwriters Laboratories (UL), American Gas Association (AGA), American Refrigeration Institute (ARI), or National Electrical Manufacturer's Association (NEMA), that use a label or published listing as a method of indicating compliance, proof of such conformance shall be submitted and approved. The label or listing of the specified organization will be acceptable evidence.
- C. Certificates of Conformance or Compliance: Submit original and not pre-printed certifications. Do not make statements in the certifications that could be interpreted to imply that the product does not meet all requirements.
- D. Certified Test Reports: Certified Test Reports are reports of tests conducted on previously manufactured materials or equipment identical to that proposed for use. Before delivery of materials and equipment, submit certified copies of test reports specified in the individual sections.
- E. Factory Tests: Factory tests are tests, which are required to be performed on the actual materials or equipment, proposed for use. Submit results of the tests in accordance with the requirements for laboratory test results of this Contract.
- F. Permits and Certificates of Inspection: Furnish the originals.
- G. Testing procedures and test results required in this and other sections. Furnish 2 copies. H. Other data required by other sections of this Division. Furnish 2 copies.

1.14 MAINTENANCE MANUALS

- A. Prepare maintenance manuals in accordance with Division 01.

1.15 DELIVERY, STORAGE, AND HANDLING

- A. Deliver products to the project properly identified with names, model numbers, types, grades, compliance labels, and other information needed for identification.

1.16 EQUIVALENT EQUIPMENT

- A. These specifications and/or drawings names and specifies certain equipment in detail. It also names equivalent equipment by manufacturer, which is not considered to be a "substitution".
- B. Submit equivalent equipment to the Architect for review per the requirements of Division 01, and Section "Basic Mechanical Requirements."
- C. Equipment of Manufacturers named in Division 22 will be considered equivalent to that specified in detail and/or named on the drawings if:
 - 1. The proposed equipment is of equivalent quality, capacity.
 - 2. Equipment is as fully equipped, fits the space allotted, and has physical configuration and weight similar to the equipment specified in detail.
- D. A complete lay out of an equipment room or area must be submitted for equivalent equipment. Notice space limitations. Layouts to include plans and section views at a scale of not less than 1/4" = 1 ft.
- E. The Architect shall determine the acceptability of "Equivalent Equipment."

1.17 CONSTRUCTION COST BREAK DOWN

- A. Prepare and submit for review a construction cost breakdown for the major subdivisions of the mechanical work in accordance with General and Supplemental Conditions and Division 1.
- B. Subdivide each item on the breakdown into two headings: labor and materials. Include overhead and profit in each entry.
- C. Submit one copy of the breakdown directly to the Engineer and the remaining copies sent through regular channels.

1.18 TOOLS

- A. Provide all special tools needed for proper operation and routine adjustment and maintenance of systems and equipment. Deliver tools to Owner's representative and request a receipt for same.

1.19 WARRANTIES

- A. Refer to Division 1 Section for procedures and submittal requirements for warranties. Refer to individual equipment specifications for warranty requirements.
- B. Where periods more than one year are specified in the specifications, such longer periods shall govern. However, when any component fails at any time during this period, the warranty period for such component and all other components, which are inactive because of, said failure shall be suspended. The warranty period for such components shall resume running for the remaining portion of the warranty period when failed component is completely repaired and in operation; however, in no case shall the resumed portion of the warranty period be less than 3 months in duration.
- C. Neither payment for work, nor total or partial occupancy of work by the Owner, within or prior to the warranty period specified, shall be construed as acceptance of faulty work or shall condone any negligence or omission of Contractor in doing the work.
- D. Compile and assemble the warranties specified in Division 23, into a separated set of vinyl covered, three ring binders, tabulated and indexed for easy reference.

- E. Provide complete warranty information for each item to include product or equipment to include date of beginning of warranty or bond; duration of warranty or bond; and names and addresses, and telephone numbers and procedures for filing a claim and obtaining warranty services.

1.20 SEISMIC RESTRAINT

- A. Provide seismic restraint for mechanical equipment, piping, and ductwork.
- B. Contractor shall submit certification of suitability of seismic restraint methods signed by Structural Engineer registered in State of California.
- C. Contractor may refer to details applicable in the SMACNA, "GUIDELINES FOR SEISMIC RESTRAINT OF MECHANICAL SYSTEMS", using the 'g' forces for "other buildings" classification CCR Title 24. Deliver a copy of these Guidelines to the Owner's Resident Inspector.

1.21 SYSTEM OPERATIONAL TEST

- A. The Contractor shall inform the Owner one week prior to starting this testing in order that the Owner's representative may be present.
- B. After balancing and prior to final inspection, the contractor shall operate all systems continuously trouble free and stable for a minimum period of fourteen (14) consecutive days including Saturday and Sunday. Each day shall be a minimum of an 8-hour day. Should a problem arise, the fourteen (14) day period shall be restarted and repeated until successfully operated for full 14 days. A written report certified by the Owner's representative shall indicate the successful completion of a stable and trouble free 14-day period.

PART 2 PRODUCTS

2.01 MATERIALS AND EQUIPMENT

- A. Standard Products: Materials and equipment shall be essentially the standard cataloged products of manufacturers regularly engaged in production of such materials or equipment and shall be their latest standard designs that comply with the specification requirements.
- B. Materials and equipment shall duplicate items that have been in satisfactory commercial or industrial use at least two years prior to bid opening, unless more stringent requirements are specified. Where two or more units of the same type of equipment are required, these units shall be products of a single manufacturer. The components thereof, however, are not required to be exclusively of the same manufacturer.
- C. Each major component of equipment shall have manufacturer's name, address, model, and serial number on a nameplate securely affixed in a conspicuous place. The nameplate of the distributing agent will not be acceptable.
- D. Whenever on the plans, or in these specifications, products are identified by the name of one manufacturer, it is intended that equivalent products of other manufacturers are acceptable, unless otherwise indicated, if accepted as a substitution by the Architect.
- E. Where three or more manufacturers are listed as "acceptable manufacturers" however, then the products furnished shall be the product of one of the manufacturers listed. Manufacturers listed as "acceptable manufacturers" shall be considered "Equivalents" and shall meet quality and performance of a particular one specified by both name and catalog number.

2.02 PRODUCT LISTING

- A. When two or more items of same material or equipment are required (plumbing fixtures, pumps, valves, air conditioning units, etc.) they shall be of the same manufacturer. Product manufacturer uniformity does not apply to raw materials, bulk materials, pipe, tube, fittings (except flanged and

grooved types), sheet metal, wire, steel bar stock, welding rods, solder, fasteners, motors for dissimilar equipment units, and similar items used in Work, except as otherwise indicated.

2.03 NAMEPLATE DATA

- A. Provide permanent operational data nameplate on each item of power operated mechanical equipment, indicating manufacturer, product name, model name, serial number, capacity, operating and power characteristics, labels of tested compliances, and similar essential data. Locate nameplates in an accessible location.

2.04 SUBSTITUTIONS

- A. General: Submittals of "Substitutions" shall be in accordance with requirements of Division 1. B. By proposing a substitution, it is deemed that the Contractor shall bear the cost of any changes (whether architectural, structural, electrical or mechanical) necessary to accommodate the substitution, if said substitution is accepted.
- C. Specific: Refer to other sections of this Division for additional requirements.

2.05 SUBMITTALS

- A. General: Make submittals in accordance with requirements of Division 1.
- B. Specific: Refer to other sections of this Division for additional requirements.

PART 3 EXECUTION

3.01 WORKMANSHIP AND INSTALLATION METHODS

- A. Workmanship shall be in the best standard practice of the trade.
- B. Install equipment in accordance with the manufacturer's instructions and recommendations unless otherwise noted or specified.

3.02 TEST

- A. General:
 - 1. Demonstrate that all components of the work of this Division have been provided and that they operate in accordance with the Contract Documents.
 - 2. Provide instruments and personnel for tests and demonstrations. Submit signed test results.
- B. Specific: Refer to the other sections of this Division for test requirements.

3.03 ROUGH-IN

- A. Verify final locations for rough-ins with field measurements and with the requirements of the actual equipment to be connected.
- B. Refer to equipment specifications in Divisions 02 through 23 for rough-in requirements.

3.04 MECHANICAL INSTALLATIONS

- A. General: Sequence, coordinate, and integrate the various elements of mechanical systems, materials, and equipment. Comply with the following requirements:
 - 1. Coordinate mechanical systems, equipment, and materials installation with other building components.
 - 2. Verify all dimensions by field measurements.
 - 3. Arrange for chases, slots, and openings in other building components during progress of construction, to allow for mechanical installations.
 - 4. Coordinate the installation of required supporting devices and sleeves to be set in poured-in-place concrete and other structural components, as they are constructed.

5. Sequence, coordinate, and integrate installations of mechanical materials and equipment for efficient flow of the Work. Give particular attention to large equipment requiring positioning prior to closing in the building.
6. Where mounting heights are not detailed or dimensioned, install systems, materials, and equipment to provide the maximum headroom possible.
7. Coordinate connection of mechanical system with exterior underground and overhead utilities and services. Comply with requirements of governing regulations, franchised service companies, and controlling agencies. Provide required connection for each service.
8. Install systems, materials, and equipment to conform with approved submittal data, including coordination drawings, to greatest extent possible. Conform to arrangements indicated by the Contract Documents, recognizing that portions of the Work are shown only in diagrammatic form. Where coordination requirements conflict with individual system requirements, refer conflict to the Architect.
9. Install systems, materials, and equipment level and plumb, parallel and perpendicular to other building systems and components, where installed exposed in finished spaces.
10. All mechanical equipment to facilitate servicing, maintenance, and repair or replacement of equipment components in full compliance with the equipment manufacturer's recommendations. If the drawings or the manufacturer does not provide a specific space requirement for servicing equipment, provide as a minimum, horizontal distance of 36" from face of equipment to opposite vertical surface.
11. Install access panels or doors where units are concealed behind finished surfaces.
12. Install systems, materials, and equipment giving right-of-way priority to systems required to be installed at a specified slope.
13. Any equipment located above a ceiling that has any component, which is serviceable shall be installed within 12" of the top of the ceiling.

3.05 CUTTING AND PATCHING

- A. General: Perform cutting and patching in accordance with Division 01. In addition to the requirements specified in Division 01, the following requirements apply:
 1. Protection of Installed Work: During cutting and patching operations, protect adjacent installations.
- B. Perform cutting, fitting, and patching of mechanical equipment and materials required to:
 1. Uncover Work to provide for installation of ill-timed Work.
 2. Remove and replace defective work.
 3. Remove and replace Work not conforming to requirements of the Contract Documents.
 4. Remove samples of installed Work as specified for testing.
 5. Install equipment and materials in existing structures.
 6. Upon written instructions from the Architect, uncover and restore Work to provide for Architect/Engineer observation of concealed Work.
- C. Cut, remove and legally dispose of selected mechanical equipment, components, and materials as indicated, including but not limited to removal of mechanical piping, heating units, plumbing fixtures and trim, and other mechanical items made obsolete by the new Work.
- D. Protect the structure, furnishings, finishes, and adjacent materials not indicated or scheduled to be removed.
- E. Provide and maintain temporary partitions or dust barriers adequate to prevent the spread of dust and dirt to adjacent areas.
- F. Patch existing finished surfaces and building components using experienced installers and new materials matching existing materials. For installer's qualifications refer to the materials and methods required for the surface and building components being patched.

3.06 DELIVERY, HANDLING, STORAGE OF MATERIALS AND PROTECTION OF WORK

- A. Protect materials against dirt, water, chemical and mechanical damage both while in storage and during construction.
- B. Cover materials in such a manner that no finished surfaces will be damaged, marred or splattered with plaster or paint, and all moving parts will be kept clean and dry.
- C. Replace or refinish any damaged materials including fronts of control panels, ductwork fittings, and shop-fabricated ductwork.
- D. Keep cabinets and other openings closed to prevent entry of foreign matter. E. Specific:
Refer to other sections of this Division for additional requirements.

3.07 PROJECT CONDITIONS

- A. Check and coordinate for clearance, accessibility and placement of equipment either by going through openings provided or by placing equipment during construction. Ordering of equipment to be shipped disassembled, or disassembly of equipment at Project Site and reassembly of equipment to accomplish this requirement shall be executed without additional cost. Where provided openings are inadequate to accommodate equipment, provide new openings and restoration of same, all at no additional cost. Obtain written approval for new openings before proceeding.
- B. Verify location of all plumbing fixtures and equipment within finished spaces with the Architectural Drawings. In the event that Mechanical Drawings do not indicate exact locations, or are in conflict with the Architectural Drawings, obtain information regarding proper locations. Installation of work without proper instruction under such circumstances will result in relocation of work, when directed, without additional cost.

3.08 INSTRUCTION TO OWNER PERSONNEL

- A. When specified in other sections, the Contractor shall furnish, without additional expense to the Owner, the services of competent instructors who will give full instruction to the designated personnel in the adjustment, operation, and maintenance, including pertinent safety requirements, of the equipment or system specified. Each instructor shall be thoroughly familiar with all parts of the installation and shall be trained in operating theory as well as practical operation and maintenance of work. Instruction shall be given at the Owner's convenience. The number of man-days (eight-hours) of instruction furnished shall be as specified in other sections. When more than four man-days of instruction are specified, approximately half of the time shall be used for classroom instruction. All other time shall be used for instruction with the equipment or system. When significant changes or modifications are made under the terms of the contract, provide additional instructions to acquaint the operating personnel with the changes or modifications.
- B. Contractor shall electronically record, both visual and audio, instruction to Owner's personnel on the maintenance and operation of the mechanical systems.
- C. Submit certification, signed by Owner's agent that instructions have been completed and a DVD of the instruction has been reviewed and delivered to the Owner.
- D. Printed operating instructions and a copy of wiring diagrams are to be mounted in all equipment areas, framed and behind glass or encased in plastic. Printed operating instructions shall include steps for starting up and securing equipment. As a precedent to final acceptance three (3) copies of instructions are to be submitted to the Architect for review. Contractor shall turn over to Owner in a neat brochure form, equipment guarantee and maintenance instructions.

3.09 CLEANING

- A. Cleaning shall be done as the work proceeds. Periodically remove waste and debris to keep the site as clean as is practical.

- B. Refer the Division 1 Section: for general requirements for final cleaning.
- C. Leave exposed parts of the mechanical work in a neat, clean and usable condition, with painted surfaces unblemished and plated metal surfaces polished.
- D. Thoroughly clean all materials, equipment and appliances. Clean and prepare all surfaces to be painted. Clean the entire premises of unused materials, debris, spots and marks to the satisfaction of the Architect.
- E. Remove, thoroughly clean and replace all strainers and automatic valves after the system has been put in operation until system is clear of all foreign matter and repeat this operation after ten (10) days and again after the system has been in operation thirty (30) days. Submit certification that this operation has been completed.

3.10 SAFETY REQUIREMENTS

- A. Enclose and guard belts, pulleys, chains, gears, couplings, projecting setscrews, keys, and other rotating parts in accordance with OSHA requirements. Insulate, guard, and cover any high- temperature equipment and piping so located as to endanger personnel or create a fire hazard.

END OF SECTION

SECTION 23 05 13

COMMON MOTOR REQUIREMENTS FOR HVAC EQUIPMENT

PART 1 GENERAL

1.01 SECTION INCLUDES

- A. This Section specifies the basic requirements for electrical components, which are an integral part of packaged mechanical equipment. These components include, but are not limited to factory-installed motors, starters, and disconnect switches furnished as an integral part of packaged mechanical equipment.
- B. Specific electrical requirements (i.e. horsepower and electrical characteristics) for mechanical equipment are scheduled on Drawings.
- C. All motors, power driven equipment and automatic control equipment, except motor starters as hereinafter set forth required and connected With the work of this section of the specifications are to be furnished and installed under Division 23.
- D. Control low (24V) and control line (120V) voltage wiring, conduit and related switches and relays required for the automatic control and/or interlock of motors and equipment includes final connection, are to be furnished and installed under Division 23. Materials and installation to conform to Class 1 or 2, CAC Title 24, Article E725, and as restricted under Division 26 of these specifications.
- E. Power wiring, conduit, outlets, disconnect switches, motor starters and motor-rated contactors, and making of final connections, except as hereinafter specified, are to be furnished and installed under the Division 26 of these Specification.
- F. All power supply wiring for providing a control power source to control dampers, control valves, VAV boxes control, control transformers, etc., shall be furnished and installed under Division 26.
- G. Identify circuits and equipment as outlined in the Electrical Sections of these Specifications.
- H. Coordinate requirements for underground conduit only between buildings for control interlocks shown on the drawings. This conduit to be furnished and installed under Division 26 of these Specifications.
- I. Space provisions have been made on electrical panels for control power source.

1.02 RELATED SECTIONS

- A. Separate electrical components and materials required for field installation and electrical connections are specified in Division 26.
- B. This section applies to all Division 23 sections specifying packaged mechanical equipment.

1.03 REFERENCES

- A. NEMA Standards MG 1: Motors and Generators
- B. NEMA Standards ICS 2: Industrial Control Devices, Controllers, and Assemblies
- C. NEMA Standard 250: Enclosures for Electrical Equipment
- D. NEMA Standard KS 1: Enclosed Switches
- E. Comply with California Electrical Code.

1.04 SUBMITTALS

- A. No separate submittal is required. Submit product data for motors, starters, and other electrical components with submittal data required for the equipment for which it serves, as required by the individual equipment specification sections.

1.05 QUALITY ASSURANCE

- A. Electrical components and materials shall be UL labeled. PART 2

PRODUCTS

2.01 MOTOR

- A. Provide all motors necessary for equipment under the Mechanical Work. See Electrical Drawings for voltage and phase of electrical services.
- B. The following are basis requirements for simple or common motors. For special motors, more detailed and specific requirements are specified in the individual equipment specifications.
 1. Torque characteristics shall be sufficient to satisfactorily accelerate the driven loads.
 2. Motor sizes shall be large enough so that the driven load will not require the motor to operate in the service factor range.
 3. 2-speed motors shall have 2 separate windings on poly-phase motors.
 4. Temperature Rating: As a minimum motors shall be rated for 40 degree C environment with maximum 50 degree C temperature rise for continuous duty at full load (Class A Insulation).
 5. Starting capability: Frequency of starts as indicated by automatic control system and not less than 5 evenly time spaced starts per hour for manually controlled motors.
 6. Service Factor: 1.15 for poly-phase motors and 1.35 for single-phase motors.
 7. Motor construction: NEMA Standard MG 1, general purpose, continuous duty, Deign "B", except "C" where required for high starting torque.
 - a. Frames: NEMA Standard No. 48 or 54; use driven equipment manufacturer's standards to suit specific application.
 - b. Bearings:
 - 1) Ball or roller bearings with inner and outer shaft seals.
 - 2) Re-greasable bearings, except permanently sealed where motor is normally inaccessible for regular maintenance.
 - 3) Bearings designed to resist thrust loading where belt drives or other drives produce lateral or axial thrust in motor.
 - 4) Bearings for fractional horsepower, light duty motors, sleeve type bearings are permitted.
 - c. Enclosure Type:
 - 1) open drip-proof motors for indoor use where satisfactorily housed or remotely located during operation.
 - 2) guarded drip-proof motors where exposed to contact by employees or building occupants.
 - 3) weather protected Type I for outdoor use, Type II where not housed (Epoxy encapsulated or TEFC).
 - d. Overload protection: Polyphase built-in thermal overload protection and, where indicated, internal sensing device suitable for signaling and stopping motor at starter. Single phase, provide thermal overload protection.
 - e. Noise rating: "Quiet".
 - f. Efficiencies shall be guaranteed minimum values in accordance with the following tabulation. Efficiencies shall be established in accordance with NEMA Test Standards MG1-12.53A using IEEE Test Procedure 112, Method B:

HP	EFFICIENCY
1 - 2	81.5
3-5	86.5
7-1/2- 10	90.6
15	92.0

- g. Nameplate: Indicate the full identification of manufacturer, ratings, characteristics, construction, special features and similar information.
- h. Provide all motors with junction boxes or terminals boxes and provide adjustable slide rails for all motors with belt drives.
- i. Motors rated 1 HP and larger shall have shaft, bearings and etc. capable of operating with multiple grooved sheaves and two or more belts.
- j. V Type Belt Drives: Drives requiring not more than 2 belts; variable pitch type; size for mid-point of operating range. Drives requiring 3 or more belts; nonadjustable constant speed type. Provide belts in matched sets.

2.02 MOTOR STARTERS

- A. Unless provided as part of packaged mechanical equipment or otherwise indicated, starters for motors will be provided under Division 26. Provide to Division 26 the data necessary for motor starter heater sizing for all motors.
- B. Starters for factory packaged mechanical equipment specified under Division 23 shall be provided as part of the package.
- C. Motor Starter Characteristics:
 - 1. Enclosures: NEMA 1, general purpose enclosures with padlock ears, except in wet locations shall be NEMA 3R with conduit hubs, or units in hazardous locations, which shall have CEC proper class and division.
 - 2. Type and size of starter shall be as recommended by motor manufacturer and the driven equipment manufacturer for applicable protection and start-up condition.
- D. Manual switches shall have:
 - 1. Pilot lights and extra positions for multi-speed motors.
 - 2. Overload protection: melting alloy type thermal overload relays.
- E. Magnetic Starters:
 - 1. Maintained contact push buttons and pilot lights, properly arranged for single speed or multi-speed operation as indicated.
 - 2. Trip-free thermal overload relays, each phase.
 - 3. Interlocks, pneumatic switches and similar devices as required for coordination with control requirements of Division-23 Controls sections.
 - 4. Built-in control circuit transformer, fused from line side, where service exceeds 240 volts.
 - 5. Externally operated manual reset.
 - 6. Under-voltage release or protection.
- F. Motor Connections:
 - 1. Flexible conduit, except where plug-in electrical cords are specifically indicated.

2.03 DISCONNECT SWITCHES

- A. When applied as part of factory furnished and mounted equipment, disconnects shall meet the requirements for disconnect switches set forth in Division 26.

PART 3 EXECUTION

3.01 SEISMIC RESTRAINT

- A. All electrical devices to be seismically restrained.

END OF SECTION

SECTION 23 05 48

VIBRATION AND SEISMIC CONTROLS FOR HVAC

PART1 GENERAL

1.01 SECTION INCLUDES

- A. Extent of vibration control work required by this section is indicated on drawings and schedules, and/or specified in other Division-23 sections.
- B. Types of vibration control products specified in this section include the following:
 - 1. Fiberglass Pads and Shapes;
 - 2. Neoprene Pads;
 - 3. Vibration Isolation Springs;
 - 4. Pad-Type Isolators;
 - 5. Plate-Type Isolators;
 - 6. Double-Plate-Type Isolators;
 - 7. Threaded Double-Plate-Type Isolators;
 - 8. All-Directional Anchors;
 - 9. Neoprene Mountings;
 - 10. Spring Isolators, Free-Standing;
 - 11. Spring Isolators, Housed;
 - 12. Spring Isolators, Vertically-Restrained;
 - 13. Spring Isolators, Earthquake-Restrained;
 - 14. Seismic Snubbers;
 - 15. Thrust Restraints;
 - 16. Equipment Rails;
 - 17. Fabricated Equipment Bases;
 - 18. Inertia Base Frames;
 - 19. Roof-Curb Isolators;
 - 20. Isolation Hangers;
 - 21. Riser Isolators;
 - 22. Flexible Pipe Connectors.

1.02 RELATED SECTIONS

- A. This section is part of each Division-23 section making reference to vibration control products specified herein.
- B. Vibration control products furnished as integral part of factory-fabricated equipment are specified as part of equipment assembly in other Division-23 sections.
- C. Refer to other Division-23 sections for equipment foundations, hangers, sealants, gaskets, and other work related to vibration control work.
- D. Refer to other Division-23 sections for requirements of electrical connections to equipment isolated on vibration control products.
- E. Refer to other Division-23 sections for requirements of duct connections to air handling equipment isolated on vibration control products.

1.03 SUBMITTALS

- A. Product Data: Submit manufacturer's technical product data and installation instructions for each type of vibration control product. Submit schedule showing size, type, deflection, and location for each product furnished.
 - 1. Catalog cuts and data sheets on specific vibration isolators to be utilized, showing compliance with the specification.

2. An itemized list showing the items of equipment, piping, etc., to be isolated, the isolator type and model number selected, isolator loading and deflection, and reference to specific drawing showing frame construction where applicable.
- B. Shop Drawings: Submit manufacturer's assembly-type shop drawings indicating dimensions, weights, required clearances, and method of assembly of components. Detail bases and show location of equipment anchoring points, coordinated with equipment manufacturer's shop drawings.
1. Drawings showing equipment frame construction for each item of equipment, including dimensions, structural member sizes, support point locations, etc.
 2. Written approval of the frame design to be used, obtained from the manufacturer.
 3. Drawings showing methods for suspension, support, guides, etc., for piping and ductwork, etc.
 4. Drawings showing methods for isolation of pipes, etc., piercing walls, slabs, beams, etc.
- C. Maintenance Data: Submit maintenance data for each type of vibration control product. Include this data, product data, and shop drawings in maintenance manual in accordance with requirements of Division 1.

1.04 QUALITY ASSURANCE

- A. Manufacturer's Qualifications: Firms regularly engaged in manufacture of vibration control products, of type, size, and capacity required, whose products have been in satisfactory use in similar service for not less than 5 years.
- B. Except as otherwise indicated, obtain vibration control products from single manufacturer. C.

Engage manufacturer to provide technical supervision of installation of vibration control products.

- D. Vibration isolation manufacturer shall have the following responsibilities:
1. Determine vibration isolation sizes and locations.
 2. Provide piping and equipment isolation system as scheduled or specified.
 3. Guarantee specified isolation system deflection.
 4. Provide installation instruction and drawings.

1.05 SEISMIC RESTRAINT

- A. Provide seismic restraint for mechanical equipment, in accordance with provisions of section 1614-A-1-13 of Title-24 2007 California Building Code and ASCE 7 section 13 (Sections 13.3, 13.4 & 13.6). Piping and ductwork restraint shall be in accordance with DSA Approved "SMACNA" Guidelines for Seismic Restraint of Mechanical Systems". PART 2

PRODUCTS

2.01 ACCEPTABLE MANUFACTURERS

- A. Manufacturer: Subject to compliance with requirements, provide vibration control products of one of the following:
1. Mason Industries, Inc.
 2. Consolidated Kinetics, Inc.
 3. Or approved equal
- B. Except as otherwise indicated mechanical equipment shown on drawings shall be isolated from the structure by means of resilient vibration and noise isolators supplied by a single manufacturer to the Contractor.

2.02 VIBRATION ISOLATION AND SEISMIC RESTRAINTS

A. Type and Description:

1. Type PN is a molded pad. The area of pad shall be chosen to match the load in order to achieve the required static deflection.
2. Type MN is a molded neoprene in shear element equipped with leveling bolts and base-plate with bolt holes to permit attachment to the building structure where required.
3. Type HN is a suspension hanger with a steel box frame and a molded neoprene in shear element. A neoprene grommet shall be provided at the location where the hanger rod passes through the hanger box so that no metal-to-metal contact occurs.
4. Type MS is a bare, stable, steel spring equipped with leveling bolts and with a minimum 1/4" thick ribbed neoprene pad under the base-plate. Bolt holes shall be provided in the base-plate to permit attachment to the building structure where required.
5. Type MSL is a bare, stable, steel spring with a ribbed neoprene pad under the base-plate. Bolt holes shall be provided in the base-plate to permit attachment to the building structure. Limit stops shall be provided to prohibit spring extension if the load is removed. These stops may also serve as rigid blocking during erection so that the installed and operating heights shall be the same. Clearance shall be maintained around restraining bolts and between the limit stops and the housing so as not to interfere with the spring action.
6. Type HS is a suspension hanger with a steel box frame and a steel spring resting on a neoprene cup. The cup shall contain a steel washer designed to evenly distribute the load to the neoprene and prevent its overload or extrusion. The spring diameter and hanger box lower hole size shall be large enough to permit the hanger rod to swing through a 30-degree arc before contacting the hole and short circuiting the spring. Hangers shall be provided with an eye bolt on the spring end.
7. Type CMS is prefabricated spring isolation curb for rooftop equipments. The lower member shall consist of a rectangular steel tube containing adjustable and removable steel springs that support the upper floating section. The upper frame must provide continuous support for the equipment and must resiliently resist wind and seismic forces. All-directional neoprene snubber bushings shall be a minimum of 1/2" thick. Steel springs shall rest on 1/2" thick neoprene acoustical pads and have a static deflection as indicated on the project drawings. Hardware must be cadmium plated or galvanized and the springs plated or provided with an approved rust-resistant finish. Weatherproofing shall be provided by a continuous flexible aluminum seal joined at the corners by flexible frictionless neoprene bellows. The aluminum seal must be nailed over and provided counter flashing to the curb's waterproofing. Access ports with waterproof covers shall be provided at each spring location and 2" thermal insulation shall be included on the lower sides of the curb.
8. Type SF is a flexible neoprene pipe connector. They shall be manufactured of multiple plies of nylon tire cord fabric and neoprene both molded and cured in hydraulic rubber presses. No steel wire or rings shall be used as pressure reinforcement. Straight connectors shall have two spheres. Neoprene elbows shall be manufactured with a single sphere forming the corner of the joint itself. Connectors up to and including 2" diameter may have threaded ends. Connectors 2-1/3" and larger shall be manufactured with floating steel flanges recessed to lock the connector's raised face neoprene flanges. All connectors shall be rated with either flanged or screwed twin spheres properly pre-extended as recommended by the manufacturer to prevent additional elongation under pressure. Connectors shall be provided with control units, in accordance with the manufacturer's recommendations to limit expansion.

B. Specifications are based on the following Mason Industries models:

C. Type Description	Mason Model#
1) PN Neoprene Pad	w
2) MN Neoprene Mount	ND

3)	HN Neoprene Hanger	HD
4)	MS Spring Mount	SLF
5)	MSL Spring Mount with Limit Stop	SLR
6)	HS Spring Hanger	W30
7)	CMS Spring ISO Curb	RSC
8)	SF Flexible Pipe Connector	SFDEJ

2.03 EQUIPMENT FRAMES

- A. General: Mounting frames and/or brackets shall be provided to carry the load of the equipment without causing mechanical distortion or stress to the equipment.
- B. Frame Types:
 - 1. Type A frame is wide flange structure steel frame with height saving brackets as shown on the drawings. Mason WFSL
 - 2. Type B frame is a channel steel structural frame with brackets as shown on the drawings. Mason MSL
 - 3. Type C no frame required, isolators directly attached to equipment.

2.04 SEISMIC RESTRAINTS

- A. Type I, Rigidly Mounted Equipment: Attach to the structure with attachments to resist a lateral force per code requirements.
- B. Type II, Vibration Isolated Equipment:
 - 1. Mount all vibration isolated equipment on rigid steel frames as described in the vibration control specifications unless the equipment manufacturer certified direct attachment capability.
 - 2. Each vibration isolated frame shall have a minimum of four all-directional seismic snubbers that are double acting and located as close to the vibration isolators as possible to facilitate attachment to the base and the structure.
 - 3. The snubber shall consist of interlocking steel members restrained by shock absorbent rubber material compounded to bridge bearing specifications.
 - 4. Elastomeric materials, replaceable and a minimum of 1/4 inch thick. Snubbers, manufactured with an air gap between hard and resilient material of not less than 1/8 inch or more than 1/4 inch. Install snubbers with factory set clearances.
 - 5. Snubbers shall be pre-approved by the State of California.
 - 6. The capacity of the seismic snubber at 3/8 inch deflection shall be 3 to 4 time the load assigned to the mount grouping in its immediate area. Submittals shall include the load deflection curves up to 1/2-inch deflection in the x, y and z planes. Conduct test in an independent laboratory or under the signed supervision of an independent registered engineer. Bolt snubber assemblies to the test machine as the snubber is normally installed.
 - 7. Test report shall certify that neither the neoprene elements nor the snubber body sustained any obvious deformation after release of load.
- C. Type III, Seismic Restraint of Vibration Isolated Suspended Piping:
 - 1. Brace all piping per DSA Approved "SMACNA Guidelines for Seismic Restraint of Mechanical Systems".
 - 2. The cable size and attachment to the pipe and structure shall be designed and signed by a licensed engineer in the State of California.
 - 3. Use a slack cable system of a minimum 5/16" aircraft at a minimum of 40 feet on center.
 - 4. Support insulated piping systems per DSA Approved "SMACNA Guidelines for Seismic Restraint of Mechanical Systems".

5. Piping 2 inches and smaller is exempt from special seismic bracing requirement.
- D. Type IV, Suspended Vibration Isolated Equipment:
 1. Utilize a slack cable restraint system.
 2. The cable size and attachment shall be designed and signed by an engineer licensed in the State of California.
- E. All Mechanical ductwork shall be installed with seismic restraint per DSA Approved "SMACNA Guidelines for Seismic Restraint of Mechanical Systems". A copy of the guidelines published by SMACNA shall be kept on the job site at all times during construction.

2.05 DUCTWORK

- A. Brace all ductwork including insulated ductwork per DSA Approved "SMACNA Guidelines For Seismic Restraint of Mechanical Systems".
- B. Flexible connections shall be incorporated in the ductwork attachment to all fan and coil units. PART 3

EXECUTION

3.01 GENERAL

- A. Report - The vibration isolation manufacturer, or his representative, shall be responsible for providing such supervision as may be necessary to assure correct installation and adjustment of the isolators. Upon completion of the installation and after the system is put into operation, the manufacturer, or his representative, shall make a final inspection and submit his report to the Architect in writing, certifying the correctness of installation and compliance with approved submittal data.
- B. No equipment or pipe shall be installed which makes rigid contact with the "building" unless it is approved in this specification or by the architect. "Building" includes slabs, beams, studs, walls, latch, etc.
- C. Install flexible connectors at all connections to pumps and chillers. Connectors shall be Mason Safeflex constructed of peroxide cured EPDM material and Kevlar reinforcing.

3.02 MOUNTING

- A. Isolation Configuration for Floor Mounted or Suspended Equipment: Provide a maximum of four vibration isolators located at the corners of the equipment unless approval is obtained for additional isolators. Where feasible, provide three isolators.

3.03 EQUIPMENT ISOLATOR

- A. The equipment to be isolated shall be supported by a structural steel frame or attached directly to the machine where no frame is required.
- B. Brackets shall be provided to accommodate the isolator. The vertical position and size of the bracket shall be specified by the isolator manufacturer.
- C. The minimum operating clearance between the frame and the pad or floor shall be 1 inch. D. The minimum operating clearance between the bracket and the pad or floor shall be 1 inch.
- E. The frame shall be placed in position and the brackets supported temporarily by 1 inch shims prior to the installation of the machine or isolators.
- F. After the entire system installation is completed and under full operation load, the isolator shall be adjusted so that the load is transferred from the shims to the isolator. When all isolators are properly adjusted, the shims shall be used as a gauge to check that the clearance is maintained so that the system will remain free of stress.

3.04 PIPING ISOLATOR, VERTICAL RISER OR HORIZONTALLY SUPPORTED

A. The objective and installation procedure is similar to the Equipment Isolator Installation procedures.

3.05 PIPING ISOLATOR, HORIZONTALLY SUSPENDED PIPING

A. The isolators shall be installed with the isolator hanger box as close as possible to the structure. B. The isolators shall be suspended from beams, never from slab diaphragms between beams unless specifically approved by the Architect.

C. Hanger rods shall be aligned to clear the hanger box.

3.06 DUCTWORK

A. Flexible connections shall be incorporated in the ductwork attachment to all air moving units supported with isolators. Connections shall be as herein specified.

3.07 INSTALLATION OF SEISMIC RESTRAINT

A. All seismic restraints must be installed and adjusted so that the equipment and piping vibration isolation is not degraded by utilization of the restraints.

B. Equipment:

1. Position all seismic restraints with equipment in operation for proper operating clearances.
2. Weld or bolt seismic restraints to the structure.

C. Piping:

1. Install seismic bracing without compromising vibration isolation.
2. Provide seismic restraint for all piping in equipment rooms, in shafts, and in ceilings of occupied spaces.

D. Ductwork:

1. Install seismic bracing without compromising vibration isolation.
2. Provide seismic restraint for all ductwork in equipment rooms, in shafts, and in ceilings of occupied spaces.

3.08 ISOLATION SCHEDULE

Vibration Isolation Schedule				
Equipment	Isolator Spec. Type	Deflection n	Restraint Type	Notes
Chilled Water & Heating Water Piping at Pumps & oil Connections	SF	N/A	SFDEJ	Flexible Pipe Connector
Split Air Conditioner outdoor Condenser unit	LREBP	1.0"	MSL& Integral To SLREBP	Welded Angle Iron Frame
Suspended Chilled & Heating Water Piping	HS	1.0"	PC30/ Cable	Clevis or Trapeze Mount W/ Seismic Cables
Roof or Floor Supported Chilled & Heating Water Piping	SLRS	1.0"	MSL& Integral To SLRS	Welded Angle Iron Frame

Roof Mounted Exhaust Fan Unit	ISC	1.0"	Integral To ISC	Rooftop Spring Isolation Curb
Air Handling Units External to unit:		N/A	N/A	Down Discharge Air Handling Units
Internal to unit:		..	N/A	
Suspended Equipment's	HS	1"	PC30	Fan coil units & In-line Exhaust fan units

END OF SECTION

SECTION 23 05 53

IDENTIFICATION FOR HVAC PIPING AND EQUIPMENT

PART1 GENERAL

1.01 SECTION INCLUDES

- A. Extent of mechanical identification work required by this section is indicated on drawings or specified in other Division-23 sections, and includes the following:
 - 1. Painted Identification Materials
 - 2. Plastic Pipe Markers
 - 3. Plastic Tape
 - 4. Underground-Type Plastic Line Marker
 - 5. Plastic Duct Markers
 - 6. Valve Tags
 - 7. Diagram and Schedule Frames
 - 8. Engraved Plastic-Laminate Signs
 - 9. Plastic Equipment Markers
 - 10. Plasticized Tags
 - 11. Equipment Marker

1.02 RELATED SECTIONS

- A. This section makes reference to identification devices specified herein.
- B. Mechanical identification furnished as part of factory-fabricated equipment, is specified as part of equipment assembly in other Division-23 sections.
- C. Refer to Division-26 Sections for identification requirements of electrical work; not work of this section.

1.03 SUBMITTALS

- A. Product Data: Submit manufacturer's technical product data and installation instructions for each identification material and device required.
- B. Samples: Submit samples of each color, lettering style and other graphic representation required for each identification material or system.
- C. Schedules and Diagrams:
 - 1. Submit valve schedule for each piping system, typewritten and reproduced on 8-1/2" x 11" bond paper. Tabulate valve number, piping system, system abbreviation (as shown on tag), location of valve (room or space), and variations for identification (if any). Mark valves which are intended for emergency shut-off and similar special uses, by special "flags", in margin of schedule.
 - 2. Submit temperature control diagrams and Sequence of Operation on bond paper suitable for framing.
- D. Maintenance Data: Include product data and schedules in maintenance manuals; in accordance with requirements of Division 1 and Division 23, Section 23 05 00 "Common Work Results for HVAC".

1.04 QUALITY ASSURANCE

- A. Codes and Standards:
 - 1. ANSI Standards: Comply with ANSI A13.1 for lettering size, length of color field, colors, and viewing angles of identification devices.
 - 2. No adhesive type identification markers will be accepted. All markers and tags shall be permanently attached to pipe, etc.

3. All identification markers installed exterior of buildings shall be ultra-violet resistant. PART 2

PRODUCTS

2.01 ACCEPTABLE MANUFACTURERS

- A. Manufacturer: Subject to compliance with requirements, provide mechanical identification materials of one of the following:
 1. Allen Systems, Inc.
 2. Brady (W.H.) Co.; Signmark Div.
 3. Industrial Safety Supply Co., Inc.
 4. Seton Name Plate Corp.

2.02 MECHANICAL IDENTIFICATION MATERIALS

- A. General: Provide manufacturer's standard products of categories and types required for each application as referenced in other Division-23 sections. Where more than a single type is specified for application, selection is Installer's option, but provide a single selection for each product category.

2.03 PLASTIC PIPE MARKERS

- A. Snap-On Type: Provide manufacturer's standard pre-printed, semi-rigid snap-on, color-coded pipe markers, complying with ANSI A13.1.
- B. Insulation: Furnish 1" thick molded fiberglass insulation with jacket for each plastic pipe marker to be installed on un-insulated pipes subject to fluid temperatures of 125oF (52oC) or greater. Cut length to extend 2" beyond each end of plastic pipe marker.
- C. Small Pipes: For external diameters less than 6" (including insulation if any), provide full-band pipe markers, extending 360 degrees around pipe at each location, fastened by one of the following methods:
 1. Snap-on application of pre-tensioned semi-rigid plastic pipe marker.
 2. Laminated or bonded application of pipe marker to pipe (or insulation).
 3. Taped to pipe (or insulation) with color-coded plastic adhesive tape, not less than 3/4" wide; full circle at both ends of pipe marker, tape lapped 1-1/2".
- D. Large Pipes: For external diameters of 6" and larger (including insulation if any), provide either full-band or strip-type pipe markers, but not narrower than 3 times letter height (and of required length), fastened by one of the following methods:
 1. Laminated or bonded application of pipe marker to pipe (or insulation).
 2. Taped to pipe (or insulation) with color-coded plastic adhesive tape, not less than 1-1/2" wide; full circle at both ends of pipe marker, taped lapped 3".
 3. Strapped-to-pipe (or insulation) application of semi-rigid type, with manufacturer's standard stainless steel bands.
- E. Lettering: Manufacturer's standard pre-printed nomenclature which best describes piping system in each instance, as selected by Architect/Engineer in cases of variance with names as shown or specified.
 1. Arrows: Print each pipe marker with arrows indicating direction of flow, either integrally with piping system service lettering (to accommodate both directions), or as a separate unit of plastic.

2.04 PLASTIC TAPE

- A. General: Provide manufacturer's standard color-coded pressure-sensitive (self-adhesive) vinyl tape, not less than 3 mils thick.
- B. Width: Provide 1-1/2" wide tape markers on pipes with outside diameters (including insulation, if any) of less than 6", 2-1/2" wide tape for larger pipes.
- C.. Color: Comply with ANSI A13.1, except where another color selection is indicated.

2.05 UNDERGROUND-TYPE PLASTIC LINE MARKER

- A. General: Manufacturer's standard permanent, bright-colored, continuous-printed plastic tape, intended for direct-burial service; not less than 6" wide x 4 mils thick. Provide tape with printing which most accurately indicates the type of service of buried pipe.
 - 1. Provide multi-ply tape consisting of solid aluminum foil core between 2-layers of plastic tape.

2.06 VALVE TAGS

- A. Brass Valve Tags: Provide 19-gage polished brass valve tags with stamped-engraved piping system abbreviation in 1/4" high letters and sequenced valve numbers 1/2" high and with 5/32" hole for fastener.
 - 1. Provide 1-1/2" diameter tags, except as otherwise indicated.
 - 2. Fill tag engraving with black enamel.
- B. Valve Tag Fasteners: Provide manufacturer's standard solid brass chain (wire link or beaded type), or solid brass S-hooks of the sizes required for proper attachment of tags to valves, and manufactured specifically for that purpose.
- C. Access panel markers: Provide manufacturer's standard solid brass chain (wire link or beaded type), or solid brass S-hooks of the sizes required for proper attachment of tags to valves, and manufactured specifically for that purpose.
- D. Access Panel Markers: Provide manufacturer's standard 1/16" thick engraved plastic laminate access panel markers, with abbreviations and numbers corresponding to concealed valve. Include 1/8" center hole to allow attachment.

2.07 DIAGRAM AND SCHEDULE FRAMES

- A. General: For each page of schedule and/or diagrams, provide glazed display frame, with screws for removable mounting on masonry walls. Provide frames of finished hardwood or extruded aluminum, with SSB-grade sheet glass.

2.08 ENGRAVED PLASTIC-LAMINATE SIGNS

- A. General: Provide engraving stock melamine plastic laminate, complying with FS L-P-387, in the sizes and thicknesses indicated, engraved with engraver's standard letter style of the sizes and wording indicated, white with black core (letter color) except as otherwise indicated, punched for mechanical fastening except where adhesive mounting is necessary because of substrate.
- B. Thickness: 1/16" for units up to 20 sq. in. or 8" length; 1/8" for larger units.
- C. Fasteners: Self-tapping stainless steel screws, except contact-type permanent adhesive where screws cannot or should not penetrate the substrate.

2.09 LETTERING AND GRAPHICS

- A. General: Coordinate names, abbreviations and other designations used in mechanical identification work, with corresponding designations shown, specified or scheduled. Provide numbers, lettering and wording as indicated, as recommended by manufacturers or as required for proper identification and operation/maintenance of mechanical systems and equipment.
 - 1. Multiple Systems: Where multiple systems of same generic name are shown and specified, provide identification which indicates individual system number as well as service (as examples; Boiler No. 3, Air Supply No. 1H, Standpipe F12).

2.10 EQUIPMENT MARKERS

- A. Equipment Nameplates: Metal, with data engraved or stamped, for permanent attachment on equipment.

1. Data:
 - a. Manufacturer, product name, model number, and serial number.
 - b. Capacity, operating and power characteristics, and essential data. c. Labels of tested compliances.
 2. Location: Accessible and visible.
 3. Fasteners: As required to mount on equipment.
- B. Equipment Markers: Engraved, color-coded laminated plastic. Include contact-type, permanent adhesive.
1. Terminology: Match schedules as closely as possible.
 2. Data.
 3. Name and plan number. a. Equipment service. b. Design capacity. c. Other design parameters such as pressure drop, entering and leaving conditions, and speed.
 4. Size: 2-1/2 by 4 inches for control devices, dampers, and valves; 4-1/2 by 6 inches for equipment.
- C. Equipment Signs: ASTM D 709, Type I, cellulose, paper-base, phenolic-resin-laminate engraving stock; Grade ES-2, black surface, black phenolic core, with white melamine sub-core, unless otherwise indicated. Fabricate in sizes required for message. Provide holes for mechanical fastening.
1. Data: Instructions for operation of equipment and for safety procedures.
 2. Engraving: Manufacturer's standard letter style, of sizes and with terms to match equipment identification.
 3. Retain and edit subparagraph above or first subparagraph below.
 4. Thickness: 1/16 inch for units up to 20 sq. in. or 8 inches in length, and 1/8 inch for larger units.
 5. Fasteners: Self-tapping, stainless-steel screws or contact-type, permanent adhesive.
- D. Access Panel and Door Markers: 1/16-inch thick, engraved laminated plastic, with abbreviated terms and numbers corresponding to identification. Provide 1/8-inch center hole for attachment.
1. Fasteners: Self-tapping, stainless-steel screws or contact-type, permanent adhesive.

2.11 PLASTIC DUCT MARKERS

- A. Engraved, color-coded laminated plastic. Include direction and quantity of airflow and duct service (such as supply, return, and exhaust). Include contact-type, permanent adhesive.

PART 3 EXECUTION

3.01 GENERAL INSTALLATION REQUIREMENTS

- A. Coordination: Where identification is to be applied to surfaces which require insulation, painting or other covering or finishes, including valve tags in finished mechanical spaces, install identification after completion of covering and painting. Install identification prior to installation of acoustical ceilings and similar removable concealment.

3.02 PIPING SYSTEM IDENTIFICATION

- A. General: Install pipe markers of one of the following types on each system indicated to receive identification, and include arrows to show normal direction of flow:
1. Plastic pipe markers, with application system as indicated under "Materials" in this section. Install on pipe insulation segment where required for hot-non-insulated pipes.
- B. Locate pipe markers as follows wherever piping is exposed to view in occupied spaces, machine rooms, accessible maintenance spaces (shafts, tunnels, plenums) and exterior non-concealed locations.
1. Near each valve and control device.
 2. Near each branch, excluding short take-offs for fixtures and terminal units; mark each pipe at branch, where there could be question of flow pattern.
 3. Near locations where pipes pass through walls, floors ceilings, or enter non-accessible enclosures.
 4. At access doors, manholes similar access points which permit view of concealed piping.
 5. Near major equipment items and other points of origination and termination.

6. Spaced intermediately at maximum spacing of 50' along each piping run, except reduce spacing to 25' in congested areas of piping and equipment.
7. On piping above removable acoustical ceilings, except omit intermediately spaced markers.

3.03 UNDERGROUND PIPING IDENTIFICATION

- A. General: During back-filling/top-soiling of each exterior underground piping systems, except sanitary sewer and storm drainage install continuous underground-type plastic line marker, located directly over buried line at 6" to 8" below finished grade. Where multiple small lines are buried in common trench and do not exceed overall width of 16", install single line marker.

3.04 VALVE IDENTIFICATION

- A. General: Provide valve tag on every valve, cock and control device in each piping system; exclude check valves, valves within factory-fabricated equipment units, plumbing fixture faucets, convenience and lawn-watering hose bibs, and shut-off valves at plumbing fixtures, HVAC terminal devices and similar rough-in connections of end-use fixtures and units. List each tagged valve on valve schedule for each piping system.
- B. Mount valve schedule frames and schedules in machine rooms where indicated or, if not otherwise indicated, where directed by Architect/Engineer.

3.05 MECHANICAL EQUIPMENT IDENTIFICATION

- A. General: Install engraved plastic laminate sign or plastic equipment marker on or near each major item of mechanical equipment and each operational device, as specified herein if not otherwise specified for each item or device. Provide signs for the following general categories of equipment and operational devices:
 1. Fuel-burning units including boilers, furnaces, heaters.
 2. Pumps, compressors, chillers, condensers and similar motor-driven units.
 3. Fans and blowers.
 4. Packaged HVAC central-station or zone-type units.
 5. Split air conditioner indoor and outdoor units
 6. Single Duct terminal units and all equipment in ceiling space.(In addition to the equipment tag, install an identification tag for VAV units in locations approved by architect to indicate where each unit is installed above the ceiling. Coordinate the Installation location, type, size and color of this tag with the architect.)
- B. Lettering Size: Minimum 1/4" high lettering for name of unit where viewing distance is less than 2'-0", 1/2" high for distances up to 6'-0", and proportionately larger lettering for greater distances. Provide secondary lettering of 2/3 to 3/4 of size of the principal lettering.
- C. Test of Signs: In addition to name of identified unit, provide lettering to distinguish between multiple units, inform operator of operational requirements, indicate safety and emergency precautions, and warn of hazards and improper operations.

3.06 ADJUSTING AND CLEANING

- A. Adjusting: Relocate any mechanical identification device which has become visually blocked by work of this division or other divisions.
- B. Cleaning: Clean face of identification devices, and glass frames of valve charts.

END OF SECTION

TESTING, ADJUSTING, AND BALANCING FOR HVAC

1.01 RELATED DOCUMENTS

- A. Drawings and general provisions of the Contract, including General and Supplementary Conditions and Division 01 Specification Sections, apply to this Section.

1.02 SUMMARY

- A. This Section includes testing, adjusting, and balancing HVAC systems to produce design objectives, including the following:
 1. Balancing airflow and water flow within distribution systems, including sub-mains, branches, and terminals, to indicated quantities according to specified tolerances.
 2. Test, adjust and balance hydronic system based on the requirements of the existing variable flow chilled and heating water systems (as applicable for site system).
 3. Adjusting total HVAC systems to provide indicated quantities.
 4. Measuring electrical performance of HVAC equipment.
 5. Setting quantitative performance of HVAC equipment.
 6. Verifying that automatic control devices are functioning properly.
 7. Reporting results of the activities and procedures specified in this Section.
- B. Related Sections include the following:
 1. Testing and adjusting requirements unique to particular systems and equipment are included in the Sections that specify those systems and equipment.
 2. Field quality-control testing to verify that workmanship quality for system and equipment installation is specified in system and equipment Sections.

1.03 DEFINITIONS

- A. Adjust: To regulate fluid flow rate and air patterns at the terminal equipment, such as to reduce fan speed or adjust a damper.
- B. Balance: To proportion flows within the distribution system, including sub-mains, branches, and terminals, according to design quantities.
- C. Draft: A current of air, when referring to localized effect caused by one or more factors of high air velocity, low ambient temperature, or direction of airflow, whereby more heat is withdrawn from a person's skin than is normally dissipated.
- D. Procedure: An approach to and execution of a sequence of work operations to yield repeatable results.
- E. Report Forms: Test data sheets for recording test data in logical order.
- F. Static Head: The pressure due to the weight of the fluid above the point of measurement. In a closed system, static head is equal on both sides of the pump.
- G. Suction Head: The height of fluid surface above the centerline of the pump on the suction side. H. System Effect: A phenomenon that can create undesired or unpredicted conditions that cause reduced capacities in all or part of a system.
- I. System Effect Factors: Allowances used to calculate a reduction of the performance ratings of a fan when installed under conditions different from those presented when the fan was performance tested.

- J. Terminal: A point where the controlled medium, such as fluid or energy, enters or leaves the distribution system.
- K. Test: A procedure to determine quantitative performance of a system or equipment.
- L. Testing, Adjusting, and Balancing Agent: The entity responsible for performing and reporting the testing, adjusting, and balancing procedures.
- M. MBC: Associated Air Balance Council.
- N. AMCA: Air Movement and Control Association.
- O. SMACNA: Sheet Metal and Air Conditioning Contractors' National Association.

1.04 SUBMITTALS

- A. Quality-Assurance Submittals: Within 30 days from the Contractor's Notice to Proceed, submit 3 copies of evidence that the testing, adjusting, and balancing Agent and this Project's testing, adjusting, and balancing team members meet the qualifications specified in the "Quality Assurance" Article below.
- B. Strategies and Procedures Plan: Within 60 days from the Contractor's Notice to Proceed, submit 3 copies of the testing, adjusting, and balancing strategies and step-by-step procedures as specified in Part 3 "Preparation" Article below. Include a complete set of report forms intended for use on this Project.
- C. Certified Testing, Adjusting, and Balancing Reports: Submit 6 copies of reports prepared, as specified in this Section, on approved forms certified by the testing, adjusting, and balancing Agent.
- D. Warranty: Submit 6 copies of special warranty specified in the "Warranty" Article below.
- E. Provide a summary of any discrepancies found in the system, by Air balance contractor to each system as described hereafter. Include a complete list of deficiencies and problems found in system being tested and balanced. Add this report to final submittal package.

1.05 QUALITY ASSURANCE

- A. Agent Qualifications: Engage a testing, adjusting, and balancing agent certified by MBC. Agent certifications to be submitted for A&E approval before testing, etc.
- B. Testing, Adjusting, and Balancing Conference: Meet with the Owner's and the Architect's representatives on approval of the testing, adjusting, and balancing strategies and procedures plan to develop a mutual understanding of the details. Ensure the participation of testing, adjusting, and balancing team members, equipment manufacturers' authorized service representatives, HVAC controls Installer, and other support personnel. Provide 7 days' advance notice of scheduled meeting time and location.
 - 1. Agenda Items: Include at least the following:
 - a. Submittal distribution requirements.
 - b. Contract Documents examination report.
 - c. Testing, adjusting, and balancing plan.
 - d. Work schedule and Project site access requirements.
 - e. Coordination and cooperation of trades and subcontractors.
 - f. Coordination of documentation and communication flow.
- C. Certification of Testing, Adjusting, and Balancing Reports: Certify the testing, adjusting, and balancing field data reports. This certification includes the following:
 - 1. Review field data reports to validate accuracy of data and to prepare certified testing, adjusting, and balancing reports.

2. Certify that the testing, adjusting, and balancing team complied with the approved testing, adjusting, and balancing plan and the procedures specified and referenced in this Specification.
- D. Testing, Adjusting, and Balancing Reports: Use standard forms from AABC "National Standards for Testing, Adjusting, and Balancing."
- E. Instrumentation Type, Quantity, and Accuracy: As described in AABC national standards.
- F. Instrumentation Calibration: Calibrate instruments at least every 6 months or more frequently if required by the instrument manufacturer.

1.06 PROJECT CONDITIONS

- A. This project will be connected to the **NAME SCHOOL/SITEAS APPLICABLE** plant. Scope of Test, adjust and balance of the hydronic systems is from point of connection to the campus chilled and heating water piping system and inside the building.
- B. Full Owner Occupancy: The Owner may occupy the site and existing building during the entire testing, adjusting, and balancing period. Cooperate with the Owner during testing, adjusting, and balancing operations to minimize conflicts with the Owner's operations.

1.07 COORDINATION

- A. Coordinate the efforts of factory-authorized service representatives for systems and equipment, HVAC controls installers, and other mechanics to operate HVAC systems and equipment to support and assist testing, adjusting, and balancing activities.
- B. Notice: Provide 7 days advance notice for each test. Include scheduled test dates and times. C. Perform testing, adjusting, and balancing after leakage and pressure tests on air and water distribution systems have been satisfactorily completed.
- D. Review division 23 contract documents to assure that the design has considered all required components necessary for a complete and successful testing, adjusting and balancing of the system as described hereafter. Prepare a report for this examination of contract documents and propose any additional components required to complete the scope of work this section no later than 45 days after the award of the contract.

1.08 WARRANTY

- A. General Warranty: The national project performance guarantee specified in this Article shall not deprive the Owner of other rights the Owner may have under other provisions of the Contract Documents and shall be in addition to, and run concurrent with, other warranties made by the Contractor under requirements of the Contract Documents.
- B. National Project Performance Guarantee: Provide a guarantee on AABC "National Standards" forms stating that AABC will assist in completing the requirements of the Contract Documents if the testing, adjusting, and balancing Agent fails to comply with the Contract Documents. Guarantee includes the following provisions:
 1. The certified Agent has tested and balanced systems according to the Contract Documents.
 2. Systems are balanced to optimum performance capabilities within design and installation limits.

PART 2 PRODUCTS (Not Applicable) PART

3 EXECUTION

3.01 EXAMINATION

- A. Examine Contract Documents to become familiar with project requirements and to discover conditions in systems' designs that may preclude proper testing, adjusting, and balancing of systems and equipment.
 - 1. Contract Documents are defined in the General and Supplementary Conditions of the Contract.
 - 2. Verify that balancing devices, such as test ports, gage cocks, thermometer wells, flow-control devices, balancing valves and fittings, and manual volume dampers, are required by the Contract Documents. Verify that quantities and locations of these balancing devices are accessible and appropriate for effective balancing and for efficient system and equipment operation.
- B. Examine approved submittal data of HVAC systems and equipment.
- C. Examine project record documents described in Division 01 Section "Project Record Documents."
- D. Examine Architect's and Engineer's design data, including HVAC system descriptions, statements of design assumptions for environmental conditions and systems' output, and statements of philosophies and assumptions about HVAC system and equipment controls.
- E. Examine equipment performance data, including fan curves. Relate performance data to project conditions and requirements, including system effects that can create undesired or unpredicted conditions that cause reduced capacities in all or part of a system. Calculate system effect factors to reduce the performance ratings of HVAC equipment when installed under conditions different from those presented when the equipment was performance tested at the factory. To calculate system effects for air systems, use tables and charts found in AMCA 201, "Fans and Systems," Sections 7 through 10; or in SMACNA "HVAC Systems--Duct Design," Sections 5 and 6. Compare this data with the design data and installed conditions.
- F. Examine system and equipment installations to verify that they are complete and that testing, cleaning, adjusting, and commissioning specified in individual Specification Sections have been performed.
- G. Examine system and equipment test reports.
- H. Examine HVAC system and equipment installations to verify that indicated balancing devices, such as test ports, gage cocks, thermometer wells, flow-control devices, balancing valves and fittings, and manual volume dampers, are properly installed, and their locations are accessible and appropriate for effective balancing and for efficient system and equipment operation.
- I. Examine systems for functional deficiencies that cannot be corrected by adjusting and balancing.
- J. Examine air-handling equipment to ensure new, clean filters (MERV 8, minimum, Pleated) in the correct size for the unit, have been installed, bearings are greased, belts are aligned and tight, and equipment with functioning controls is ready for operation.
- K. Examine strainers for clean screens and proper perforations.
- L. Examine 2-way valves for proper installation for their intended function.
- M. Examine heat-transfer coils for correct piping connections and for clean and straight fins.
- N. Examine equipment for installation and for properly operating safety interlocks and controls.
- O. Examine automatic temperature system components to verify the following:
 - 1. Dampers, valves, and other controlled devices operate by the intended controller.
 - 2. Dampers and valves are in the position indicated by the controller.

3. Integrity of valves and dampers for free and full operation and for tightness of fully closed and fully open positions. This includes dampers in multi-zone units, mixing boxes, and variable-air-volume terminals.
 4. Automatic modulating and shutoff valves, including 2-way valves, are properly connected.
 5. Thermostats are located to avoid adverse effects of sunlight, drafts, and cold walls.
 6. Sensors are located to sense only the intended conditions.
 7. Sequence of operation for control modes is according to the Contract Documents.
 8. Controller set points are set at design values. Observe and record system reactions to changes in conditions. Record default set points if different from design values.
 9. Interlocked systems are operating.
 10. Changeover from heating to cooling mode occurs according to design values.
- P. Report deficiencies discovered before and during performance of testing, adjusting, and balancing procedures.

3.02 PREPARATION

- A. Prepare a testing, adjusting, and balancing plan that includes strategies and step-by-step procedures.
- B. Complete system readiness checks and prepare system readiness reports. Verify the following:
 1. Permanent electrical power wiring is complete.
 2. Hydronic systems are filled, clean, and free of air, as applicable.
 3. Automatic temperature-control systems are operational.
 4. Equipment and duct access doors are securely closed.
 5. Balance, smoke, and fire dampers are open.
 6. Isolating and balancing valves are open and control valves are operational.
 7. Ceilings are installed in Critical areas where air-pattern adjustments are required and access to balancing devices is provided.
 8. Windows and doors can be closed so design conditions for system operations can be met.
 9. Ensure that all units have been properly sealed at their rooftop curb, and all ducting is connected and braced properly, so there is no supply air being shed to the atmosphere.
 10. Ensure that OSA dampers, and economizers are properly installed, and verify that they are actually connected and working as designed.

3.03 GENERAL TESTING AND BALANCING PROCEDURES

- A. Perform testing and balancing procedures on each system according to the procedures contained in AABC national standards and this Section.
- B. Cut insulation, ducts, pipes, and equipment cabinets for installation of test probes to the minimum extent necessary to allow adequate performance of procedures. After testing and balancing, close probe holes and patch insulation with new materials identical to those removed. Restore vapor barrier and finish according to the insulation Specifications for this Project.
- C. Mark equipment settings with paint or other suitable, permanent identification material, including damper-control positions, valve indicators, fan-speed-control levers, and similar controls and devices, to show final settings.

3.04 FUNDAMENTAL AIR SYSTEMS' BALANCING PROCEDURES

- A. Prepare test reports for both fans and outlets. Obtain manufacturer's outlet factors and recommended testing procedures. Crosscheck the summation of required outlet volumes with required fan volumes.
- B. Prepare schematic diagrams of systems' "as-built" duct layouts.
- C. Determine the best locations in main and branch ducts for accurate duct airflow measurements.
- D. Check the airflow patterns from the outside-air louvers and dampers and the return- and exhaust-air dampers, through the supply-fan discharge and mixing dampers.
- E. Locate start-stop and disconnect switches, electrical interlocks, and motor starters.

F. Verify that motor starters are equipped with properly sized thermal protection. G.

Check dampers for proper position to achieve desired airflow path.

H. Check for airflow blockages.

I. Check condensate drains for proper connections and functioning.

J. Check for proper sealing of fan coil unit components.

3.05 CONSTANT-VOLUME AIR SYSTEMS' BALANCING PROCEDURES

A. The procedures in this Article apply to constant-volume supply-, return-, and exhaust-air systems. Additional procedures are required for variable-air-volume, multi-zone, induction-unit supply-air systems and process exhaust-air systems. These additional procedures are specified in other articles in this Section.

B. Adjust fans to deliver total design airflows within the maximum allowable rpm listed by the fan manufacturer.

1. Measure fan static pressures to determine actual static pressure as follows:

- a. Measure outlet static pressure as far downstream from the fan as practicable and upstream from restrictions in ducts such as elbows and transitions.
- b. Measure static pressure directly at the fan outlet or through the flexible connection.
- c. Measure inlet static pressure of single-inlet fans in the inlet duct as near the fan as possible, upstream from flexible connection and downstream from duct restrictions.
- d. Measure inlet static pressure of double-inlet fans through the wall of the plenum that houses the fan.

2. Measure static pressure across each air-handling unit component.

- a. Simulate dirty filter operation and record the point at which maintenance personnel must change filters.

3. Measure static pressures entering and leaving other devices such as sound traps, heat recovery equipment, and air washers under final balanced conditions.

4. Compare design data with installed conditions to determine variations in design static pressures versus actual static pressures. Compare actual system effect factors with calculated system effect factors to identify where variations occur. Recommend corrective action to align design and actual conditions.

5. Adjust fan speed higher or lower than design with the approval of the Architect. Make required adjustments to pulley sizes, motor sizes, and electrical connections to accommodate fan-speed changes.

6. Do not make fan-speed adjustments that result in motor overload. Consult equipment manufacturers about fan-speed safety factors. Modulate dampers and measure fan-motor amperage to ensure no overload will occur. Measure amperage in full cooling, full heating, and economizer modes to determine the maximum required brake horsepower.

C. Adjust volume dampers for main duct, sub-main ducts, and major branch ducts to design airflows within specified tolerances.

1. Measure static pressure at a point downstream from the balancing damper and adjust volume dampers until the proper static pressure is achieved.

- a. Where sufficient space in sub-mains and branch ducts is unavailable for Pitot-tube traverse measurements, measure airflow at terminal outlets and inlets and calculate the total airflow for that zone.

2. Re-measure each sub-main and branch duct after all have been adjusted. Continue to adjust sub-mains and branch ducts to design airflows within specified tolerances.

D. Measure terminal outlets and inlets without making adjustments.

1. Measure terminal outlets using a direct-reading hood or the outlet manufacturer's written instructions and calculating factors.

- E. Adjust terminal outlets and inlets for each space to design airflows within specified tolerances of design values. Make adjustments using volume dampers rather than extractors and the dampers at the air terminals.
 - 1. Adjust each outlet in the same room or space to within specified tolerances of design quantities without generating noise levels above the limitations prescribed by the Contract Documents.
 - 2. Adjust patterns of adjustable outlets for proper distribution without drafts.

3.06 MULTIZONE SYSTEMS' ADDITIONAL PROCEDURES

- A. Set unit at full flow through the cooling coil if coil has that capacity. B. Adjust each zone damper to design airflow.

3.07 FUNDAMENTAL PROCEDURES FOR HYDRONIC SYSTEMS

- A. Prepare test reports with pertinent design data and number in sequence starting at pump to end of system. Check the sum of branch-circuit flows against approved pump flow rate. Correct variations that exceed plus or minus 5 percent.
- B. Prepare schematic diagrams of systems' "as-built" piping layouts.
- C. Prepare hydronic systems for testing and balancing according to the following, in addition to the general preparation procedures specified above:
 - 1. Open all manual valves for maximum flow.
 - 2. Check flow-control valves for specified sequence of operation and set at design flow.
 - 3. Set differential-pressure control valves at the specified differential pressure.
 - 4. Set system controls so automatic valves are wide open to heat exchangers.
 - 5. Check air vents for a forceful liquid flow exiting from vents when manually operated.

3.08 HYDRONIC SYSTEMS' BALANCING PROCEDURES

- A. Set calibrated balancing valves, if installed, at calculated pre-settings.
- B. Measure flow at all stations and adjust, where necessary, to obtain first balance.
 - 1. System components that have Cv rating or an accurately cataloged flow-pressure-drop relationship may be used as a flow-indicating device.
- C. Measure flow at main balancing station and set main balancing device to achieve flow that is 5 percent greater than design flow.
- D. Adjust balancing stations to within specified tolerances of design flow rate as follows:
 - 1. Determine the balancing station with the highest percentage over design flow.
 - 2. Adjust each station in turn, beginning with the station with the highest percentage over design flow and proceeding to the station with the lowest percentage over design flow.
 - 3. Record settings and mark balancing devices. E.
- E. Measure total building flow rate.
- F. Measure the differential-pressure control valve settings existing at the conclusions of balancing.

3.09 MOTORS

- A. Motors, 1/2 HP and Larger: Test at final balanced conditions and record the following data:
 - 1. Manufacturer, model, and serial numbers.
 - 2. Motor horsepower rating.
 - 3. Motor rpm.
 - 4. Efficiency rating if high-efficiency motor.
 - 5. Nameplate and measured voltage, each phase.
 - 6. Nameplate and measured amperage, each phase.
 - 7. Starter thermal-protection-element rating.

3.10 CONDENSING UNITS

- A. Verify proper rotation of fans and measure entering- and leaving-air temperatures. Record compressor data.

3.11 HEAT-TRANSFER COILS

- A. Water Coils: Measure the following data for each coil:
 1. Entering- and leaving-water temperatures.
 2. Water flow rate.
 3. Water pressure drop.
 4. Dry-bulb temperatures of entering and leaving air.
 5. Wet-bulb temperatures of entering and leaving air for cooling coils designed for less than 7500 CFM.
 6. Airflow.
 7. Air pressure drop.

3.12 TEMPERATURE TESTING

- A. During testing, adjusting, and balancing, report need for adjustment in temperature regulation within the automatic temperature-control system.
- B. Measure indoor wet- and dry-bulb temperatures every other hour for a period of 2 successive 8- hour days, in each separately controlled zone, to prove correctness of final temperature settings. Measure when the building or zone is occupied. C. Measure outside-air, wet- and dry-bulb temperatures.

3.13 TEMPERATURE-CONTROL VERIFICATION

- A. Verify that controllers are calibrated and commissioned.
- B. Check transmitter and controller locations and note conditions that would adversely affect control functions.
- C. Record controller settings and note variances between set points and actual measurements. D. Verify operation of limiting controllers (i.e., high- and low-temperature controllers).
- E. Verify free travel and proper operation of control devices such as damper and valve operators.
- F. Verify sequence of operation of control devices. Note air pressures and device positions and correlate with airflow and water-flow measurements. Note the speed of response to input changes.
- G. Confirm interaction of electrically operated switch transducers. H. Confirm interaction of interlock and lockout systems.
- I. Verify main control supply-air pressure and observe compressor and dryer operations.
- J. Record voltages of power supply and controller output. Determine if the system operates on a grounded or non-grounded power supply.
- K. Note operation of electric actuators using spring return for proper fail-safe operations.

3.14 TOLERANCES

- A. Set HVAC system airflow and water flow rates within the following tolerances:
 1. Supply, Return, and Exhaust Fans: Minus 5 to plus 5 percent.
 2. Fresh air intake: 0 to plus 5%.
 3. Air Outlets and Inlets: 0 to plus 10 percent.
 4. Heating-Water Flow Rate: 0 to minus 10 percent.

5. Cooling-Water Flow Rate: 0 to minus 5 percent.

3.15 REPORTING

- A. Initial Construction-Phase Report: Based on examination of the Contract Documents as specified in "Examination" Article above, prepare a report on the adequacy of design for systems' balancing devices. Recommend changes and additions to systems' balancing devices to facilitate proper performance measuring and balancing. Recommend changes and additions to HVAC systems and general construction to allow access for performance measuring and balancing devices.
- B. Status Reports: As Work progresses, prepare reports to describe completed procedures, procedures in progress, and scheduled procedures. Include a list of deficiencies and problems found in systems being tested and balanced. Prepare a separate report for each system and each building floor for systems serving multiple floors.

3.16 FINAL REPORT

- A. General: Computer printout in letter-quality font, on standard bond paper, in a fine quality 3-ring binder, tabulated and divided into sections by tested and balanced systems.
- B. Include a certification sheet in front of binder signed and sealed by the certified testing and balancing engineer.
 1. Include a list of the instruments used for procedures, along with proof of calibration.
- C. Final Report Contents: In addition to the certified field report data, include the following:
 1. Fan curves.
 2. Manufacturers' test data.
 3. Field test reports prepared by system and equipment installers.
 4. Other information relative to equipment performance, but do not include approved Shop Drawings and Product Data.
- D. General Report Data: In addition to the form titles and entries, include the following data in the final report, as applicable:
 1. Title page.
 2. Name and address of testing, adjusting, and balancing Agent.
 3. Project name.
 4. Project location.
 5. Architect's name and address.
 6. Engineer's name and address.
 7. Contractor's name and address and field technician responsible for the project.
 8. Report date.
 9. Signature of testing, adjusting, and balancing Agent who certifies the report.
 10. Summary of contents, including the following:
 - a. Design versus final performance.
 - b. Notable characteristics of systems.
 - c. Description of system operation sequence if it varies from the Contract Documents.
 11. Nomenclature sheets for each item of equipment.
 12. Data for terminal units, including manufacturer, type size, and fittings.
 13. Notes to explain why certain final data in the body of reports vary from design values.
 14. Test conditions for fans and pump performance forms, including the following:
 - a. Settings for outside-, return-, and exhaust-air dampers.
 - b. Conditions of filters.
 - c. Cooling coil, wet- and dry-bulb conditions.
 - d. Face and bypass damper settings at coils.
 - e. Fan drive settings, including settings and percentage of maximum pitch diameter.
 - f. Inlet vane settings for variable-air-volume systems.
 - g. Settings for supply-air, static-pressure controller.

- h. Other system operating conditions that affect performance.
- E. System Diagrams: Include schematic layouts of air and hydronic distribution systems. Present with single-line diagrams and include the following:
1. Quantities of outside, supply, return, and exhaust airflows.
 2. Water and steam flow rates.
 3. Duct, outlet, and inlet sizes.
 4. Pipe and valve sizes and locations.
 5. Balancing stations.
- F. Air-Handling Unit Test Reports: For air-handling units with coils, include the following:
1. Unit Data: Include the following:
 - a. Unit identification. b. Location.
 - c. Make and type.
 - d. Model number and unit size. e. Manufacturer's serial number. f. Unit arrangement and class.
 - g. Discharge arrangement.
 - h. Sheave make, size in inches, and bore.
 - i. Sheave dimensions, center-to-center and amount of adjustments in inches. j. Number of belts, make, and size.
 - k. Number of filters, type, and size.
 2. Motor Data: Include the following:
 - a. Make and frame type and size. b. Horsepower and rpm.
 - c. Volts, phase, and hertz.
 - d. Full-load amperage and service factor. e. Sheave make, size in inches, and bore.
 - f. Sheave dimensions, center-to-center and amount of adjustments in inches.
 3. Test Data: Include design and actual values for the following:
 - a. Total airflow rate in CFM.
 - b. Total system static pressure in inches wg. c. Fan rpm.
 - d. Discharge static pressure in inches wg.
 - e. Filter static-pressure differential in inches wg.
 - f. Preheat coil static-pressure differential in inches wg. g. Cooling coil static-pressure differential in inches wg. h. Heating coil static-pressure differential in inches wg. i. Outside airflow in CFM.
 - j. Return airflow in CFM.
 - k. Outside-air damper position. l. Return-air damper position. m. Vortex damper position.
- G. Apparatus-Coil Test Reports: For apparatus coils, include the following:
1. Coil Data: Include the following:
 - a. System identification. b. Location.
 - c. Coil type.
 - d. Number of rows.
 - e. Fin spacing in fins per inch. f. Make and model number.
 - g. Face area in sq. ft.

- h. Tube size in NPS.
 - i. Tube and fin materials.
 - j. Circuiting arrangement.
2. Test Data: Include design and actual values for the following:
- a. Airflow rate in CFM.
 - b. Average face velocity in FPM.
 - c. Air pressure drop in inches wg.
 - d. Outside-air, wet- and dry-bulb temperatures in deg F.
 - e. Return-air, wet- and dry-bulb temperatures in deg F.
 - f. Entering-air, wet- and dry-bulb temperatures in deg F.
 - g. Leaving-air, wet- and dry-bulb temperatures in deg F.
 - h. Water flow rate in GPM.
 - i. Water pressure differential in feet of head or psig.
 - j. Entering-water temperature in deg F.
 - k. Leaving-water temperature in deg F.
 - l. Refrigerant expansion valve and refrigerant types.
 - m. Refrigerant suction pressure in psig.
 - n. Refrigerant suction temperature in deg F.
 - o. Inlet steam pressure in psig.
- H. Fan Test Reports: For supply, return, and exhaust fans, include the following:
1. Fan Data: Include the following:
 - a. System identification.
 - b. Location.
 - c. Make and type.
 - d. Model number and size.
 - e. Manufacturer's serial number.
 - f. Arrangement and class.
 - g. Sheave make, size in inches, and bore.
 - h. Sheave dimensions, center-to-center and amount of adjustments in inches.
 2. Motor Data: Include the following:
 - a. Make and frame type and size.
 - b. Horsepower and rpm.
 - c. Volts, phase, and hertz.
 - d. Full-load amperage and service factor.
 - e. Sheave make, size in inches, and bore.
 - f. Sheave dimensions, center-to-center and amount of adjustments in inches.
 - g. Number of belts, make, and size.
 3. Test Data: Include design and actual Values for the following:
 - a. Total airflow rate in CFM.
 - b. Total system static pressure in inches wg.
 - c. Fan rpm.
 - d. Discharge static pressure in inches wg.
 - e. Suction static pressure in inches wg.
- I. Round and Rectangular Duct Traverse Reports: Include a diagram with a grid representing the duct cross-section and record the following:
1. Report Data: Include the following:
 - a. System and air-handling unit number.
 - b. Location and zone.
 - c. Traverse air temperature in deg F.
 - d. Duct static pressure in inches wg.
 - e. Duct size in inches.
 - f. Duct area in sq. ft.

- g. Design airflow rate in CFM. h. Design velocity in FPM.
- i. Actual airflow rate in CFM.
- j. Actual average velocity in FPM. k. Barometric pressure in psig.

J. Air-Terminal-Device Reports: For terminal units, include the following:

1. Unit Data: Include the following:
 - a. System and air-handling unit identification. b. Location and zone.
 - c. Test apparatus used. d. Area served.
 - e. Air-terminal-device manufacturer.
 - f. Air-terminal-device number from system diagram. g. Air-terminal-device type and model number.
 - h. Air-terminal-device size.
 - i. Air-terminal-device effective area in sq. ft.
2. Test Data: Include design and actual values for the following:
 - a. Airflow rate in CFM. b. Air velocity in FPM.
 - c. Preliminary airflow rate as needed in CFM. d. Preliminary velocity as needed in FPM.
 - e. Final airflow rate in CFM. f. Final velocity in FPM.
 - g. Space temperature in deg F.

K. System-Coil Reports: For reheat coils and water coils of terminal units, include the following:

1. Unit Data: Include the following:
 - a. System and air-handling unit identification. b. Location and zone.
 - c. Room or riser served. d. Coil make and size.
 - e. Flowmeter type.
2. Test Data: Include design and actual values for the following:
 - a. Airflow rate in CFM.
 - b. Entering-water temperature in deg F.
 - c. Leaving-water temperature in deg F.
 - d. Water pressure drop in feet of head or psig. e. Entering-air temperature in deg F.
 - f. Leaving-air temperature in deg F.

L. Instrument Calibration Reports: For instrument calibration, include the following:

1. Report Data: Include the following:
 - a. Instrument type and make. b. Serial number.
 - c. Application.
 - d. Dates of use.
 - e. Dates of calibration.

3.17 ADDITIONAL TESTS

- A. Within 90 days of completing testing, adjusting, and balancing, perform additional testing and balancing to verify that balanced conditions are being maintained throughout and to correct unusual conditions.

- B. Seasonal Periods: If initial testing, adjusting, and balancing procedures were not performed during near-peak summer and winter conditions, perform additional inspections, testing, and adjusting during near-peak summer and winter conditions.

3.17 ENERGY VALIDATION

- A. The contractor shall validate the peak summer and peak winter energy consumption and balancing conditions after occupancy of the facility by the Owner. Even though the initial testing and balancing may have been performed during a near peak summer or near peak winter period, each shall be validated after occupancy by the Owner. Sufficient funds will be withheld after these tests and validations have been completed and the results approved by the Owner.
- B. The contractor shall schedule and coordinate with the Owner dates for both the summer and winter peak energy validation testing and balancing. The contractor shall have the required instrumentation in place and sufficient personnel available to minimize disruption and inconvenience to the operation of the building and to the occupants of the building.
- C. Using approved instrumentation, data shall be collected and recorded to compute the energy consumed by each system in the building. Totals shall be compared to the values indicated for the prime utilities supplied to the building.
- D. Individual readings of flows, temperature, pressure, etc., taken with the contractor's test instruments shall be compared with corresponding, permanently installed building instrumentation. This data shall be included in the final test and balance report.
- E. If an energy analysis was generated during the design, the theoretical and the actual shall be compared. If more than a 10% difference in total energy consumptions is indicated, the differences shall be examined and a determination made as to the cause. If the actual consumption is higher than predicted, a determination shall be made as to the cause and corrective measures listed for evaluation by the Owner.

END SECTION

SECTION 23 07 00

HVAC INSULATION

PART 1 GENERAL

1.01 SECTION INCLUDES

- A. Extent of mechanical insulation required by this section is indicated on drawings and schedules, and by requirements of this section, and includes the following:
 - 1. Piping Systems Insulation:
 - a. Fiberglass.
 - b. Calcium Silicate.
 - c. Flexible Unicellular.
 - 2. Ductwork System Insulation:
 - a. Fiberglass
 - b. Flexible Unicellular.
 - 3. Equipment Insulation:
 - a. Fiberglass
 - b. Calcium Silicate
 - c. Flexible Unicellular.
 - 4. Acoustical Insulation
 - a. Fiberglass

1.02 RELATED SECTIONS

- A. Refer to Division-23 section 23 05 29 for protection saddles, protection shields, and thermal hanger shields; not work of this section.
- B. Refer to Division-23 section 23 05 53 for installation of identification devices for piping, ductwork, and equipment; not work of this section.

1.03 SUBMITTALS

- A. Product Data: Submit manufacturer's technical product data and installation instructions for each type of mechanical insulation. Submit schedule showing manufacturer's product number, K-value, thickness, and furnished accessories for each mechanical system requiring insulation.
- B. Maintenance Data: Submit maintenance data and replacement material lists for each type of mechanical insulation. Include this data and product data in maintenance manual.

1.04 QUALITY ASSURANCE

- A. Flame/Smoke Ratings: Provide composite mechanical insulation (insulation, jackets, coverings, sealers, mastics and adhesives) with flame-spread index of 25 or less, and smoke-developed index of 50 or less, as tested by ASTM E 84 (NFPA 255) method.
- B. As a minimum, insulation shall meet installed thermo (R) value as set forth in Title 24 California Code of Regulations (CCR) Part 6 Section 123, 124; and Part 4 Section 605.0, or as indicated in contract documents, whichever is greater.

1.05 DELIVERY, STORAGE, AND HANDLING

- A. Deliver insulation, coverings, cements, adhesives, and coatings to site in containers with manufacturer's stamp or label, affixed showing fire hazard indexes of products.
- B. Protect insulation against dirt, water, and chemical and mechanical damage. Do not install damaged or wet insulation; remove from project site.

PART 2 PRODUCTS

2.01 ACCEPTABLE MANUFACTURERS

- A. Manufacturer: Subject to compliance with requirements, provide products of one of the following:
1. Armstrong World Industries, Inc.
 2. Babcock and Wilcox; Insulating Products Div.
 3. Certainteed Corp.
 4. Knauf Fiber Glass GmbH.
 5. Manville Products Corp.
 6. Owens-Corning Fiberglas Corp.
 7. Pittsburgh Corning Corp.
 8. Rubatex Corp.

2.02 PIPING INSULATION MATERIALS

- A. Fiberglass (Mineral Fiber) Piping Insulation: ASTM C547, Class 1 unless otherwise indicated. Manville Products Corp. Micro-Lok, Owens-Corning Fiberglas Corp., ASJ/SL-11 or equivalent.
- B. Calcium Silicate Piping Insulation: ASTM C533, Type I. Owens-Corning Fiberglass Corp. "Kaylo Asbestos Free" or equivalent.
- C. Flexible Unicellular Piping Insulation: ASTM C534, Type I. Armstrong World Industries, Inc. or Rubatex Corp. meeting ASTM E-84 25/50 index.
- D. Jackets for Piping Insulation: ASTM C921, Type I (Vapor Barrier) for piping with temperatures below ambient. (Type II (Water Vapor Permeable) for piping with temperatures above ambient. Type I may be used for all piping at Installer's option.
1. Encase pipe fittings insulation with one-piece premolded PVC fitting covers, fastened as per manufacturer's recommendations. Zeston PVC Insulated fitting covers or equivalent.
 2. Encase exterior piping insulation with aluminum jacket with weather-proof construction.
- E. Staples, Bands, Wires, and Cement: As recommended by insulation manufacturer for applications indicated.
- F. Adhesives, Sealers, and Protective Finishes: As recommended by insulation manufacturer for applications indicated.
- G. All Insulation shall be U.L. listed showing flame spread not greater than 25, nor smoke greater than 50, per NFPA 90A.

2.03 DUCTWORK INSULATION MATERIALS

- A. Flexible Fiberglass Ductwork Insulation: ASTM C553, Type I, Class B-2, Owens-Corning Fiberglas Inc. un-faced duct wrap insulation, Type 100 or equivalent.
1. Nominal thickness or equivalent to provide installed R-value as follows:
 - a. 1.5" thick- Installed R = 4.2
 - b. 2.0" thick- Installed R = 5.6
- B. Flexible Fiberglass Ductwork Insulation: ASTM C612, with ASTM C921 Type I vapor barrier jacket. Owens/Corning Fiberglas All Service Wrap Insulation, Type 100 or equivalent:
1. Nominal thickness or equivalent to provide an installed R-value as follows:
 - a. 1.5" thick - Installed R = 4.2
 - b. 2.0" thick - Installed R = 5.6
- C. Ductwork Insulation Accessories: Provide staples, bands, wires, tape, anchors, corner angles and similar accessories as recommended by insulation manufacturer for applications indicated.
- D. Ductwork Insulation Compounds: Provide cements, adhesives, coatings, sealers, protective finishes and similar compounds as recommended by insulation manufacturer for applications indicated.

- E. All Insulation shall be U.L. listed showing flame spread not greater than 25, nor smoke greater than 50, per NFPA 90A.

2.04 EQUIPMENT INSULATION MATERIALS

- A. Flexible Fiberglass Equipment Insulation: ASTM C553, Type II, Class F-1, Owens-Corning Fiberglass, Inc., Type 701 1.5 lbs/Ft3.
- B. Calcium Silicate Equipment Insulation: ASTM C533, Type I, Block; Owens/Corning Fiberglass, Inc., Kaylo Asbestos Free, U-Grooved block insulation.
- C. Jacketing Material for Equipment Insulation: Provide canvas jacketing material, not less than 7.8 ounces per square yard, or metal jacket at Installer's option, except as otherwise indicated.
- D. Equipment Insulation Compounds: Provide adhesives, cements, sealers, mastics and protective finishes as recommended by insulation manufacturer for applications indicated.
- E. Equipment Insulation Accessories: Provide staples, bands, wire, wire netting, tape corner angles, anchors and stud piping as recommended by insulation manufacturer for applications indicated.
- F. All Insulation shall be U.L. listed showing flame spread not greater than 25, nor smoke greater than 50, per NFPA 90A.

2.05 ACOUSTICAL INSULATION

- A. Rigid Fiberglass Insulation: ASTM C612, Class 1, Owens/Corning Fiberglass, Inc., 10 lbs/ft3. PART 3

EXECUTION

3.01 INSPECTION

- A. Examine areas and conditions under which mechanical insulation is to be installed. Do not proceed with work until unsatisfactory conditions have been corrected in a manner acceptable to Installer.

3.02 HVAC PIPING SYSTEM INSULATION

- A. Insulation Omitted: Omit insulation on the following:
 1. Hot piping within radiation enclosures
 2. Hot unions, flanges, strainers, flexible connections and expansion joints.
- B. Cold Piping (40°F to ambient):
 1. Application Requirements: Insulate the following cold HVAC piping systems:
 - a. HVAC chilled water supply and return piping.
 - b. Air conditioner condensate drains piping.
 2. Insulate each piping system specified above with one of the following types and thicknesses of insulation:
 - a. Fiberglass: 1" thick for pipe sizes up to and including 4", 1-1/2" thick for pipe sizes over 4".
 - b. Flexible Unicellular: 1/2" thick for pipe sizes up to 1-1/2" (A.C. condensate piping only).
- C. Hot Low Pressure Piping (to 250°F):
 1. Application Requirements: Insulate the following hot low pressure HVAC piping systems (steam piping up to 15 psi, water piping up to 250°F (121°C)).
 - a. HVAC heating water supply and return piping.
 2. Insulate each piping system specified above with one of the following types and thicknesses of insulation:

- a. Fiberglass: 1" thick for pipe sizes up to and including 1", 1-1/2" thick for pipe sizes 1-1/2"; 2" thick for piping over 2".

3.03 DUCTWORK SYSTEM INSULATION: A.

Insulation Omitted:

- 1. Do not insulate outside air and exhaust air ductwork unless otherwise indicated.
 - 2. Do not insulate exhaust air ductwork unless otherwise indicated.
 - 3. All ductwork specified to be insulated that is located in mechanical rooms, located on roofs, or where exposed in conditioned spaces or to weather shall be internally lined under Section 23 31 13 "Metal Ductwork"; unless noted otherwise in these specifications or on the drawings.
- B. Insulate the following with flexible fiberglass insulation, unfaced, 1.5" thickness unless otherwise noted. Firmly wrap insulation around duct work with all joints lapped a minimum of 2 inches. Secure insulation to ducts by means of 16 gage soft-annealed galvanized wire spaced 12 inches on centers at loose ends.
- 1. Warm air heating ductwork in concealed spaces; unless in ceiling plenum provide all service wrap insulation.
 - 2. Return air ductwork in non-conditioned concealed spaces unless in ceiling supply plenum uses all service wrap insulation.
 - 3. Return air ductwork located in return air ceiling plenums outside air ductwork supplying fan coil units.
- C. Insulate the following with Flexible Fiberglass insulation with all service vapor barrier facing, 1.5" thickness unless noted otherwise.
- 1. HVAC hot/cold mixed air ductwork between fan discharge or HVAC unit discharge, and room terminal unit.
 - 2. Outdoor air intake ductwork between air entrance and indoor fan inlet or indoor HVAC unit inlet.
 - 3. Installation:
 - a. Neatly wrap insulation around ducts with all joints tightly butted together.
 - b. Seal transverse joints with vapor barrier facing tab overlapping all joints 2-inches and secure with vapor barrier adhesive or outward-clinch staples on 4-inches centers. c. Seal
 - d. Secure insulation to underside of ducts, 100 percent coverage, with ductwork insulation adhesive.
 - e. In addition to adhesive, on underside of ducts 24-inches or greater in width, use mechanical fasteners on maximum 12-inch centers.
 - f. Seal all penetrations of vapor barrier facing with vapor barrier mastic.
- D. Insulate the following with Rigid Fiberglass Insulation, 2.0" thickness unless noted otherwise.
- 1. HVAC and unit housings not pre-insulated at the factory or where lining has been specifically omitted.
 - 2. Installation: Fasten to ductwork with adhesive and pins per manufacturer's recommendations. Butt all joints and provide 16 gage corner angles at corners. Seal all joints with approved duct tape.
- E. Contractor's Option: Contractor may provide duct liner as set forth in Section 23 31 13, using equivalent installed "R" values; in lieu of external duct wrap or rigid insulation as specified above unless ductwork is specifically indicated as being unlined.
- F. Hot Ductwork:
- 1. Application Requirements: Insulate range and hood exhaust ductwork with PABCO "Super Fire Temp" asbestos free, non-combustible fireproofing board.

- a. Provide 1 to 4 hour fire rating as indicated.
- b. Install per manufacturer's instructions.

3.04 EQUIPMENT INSULATION

- A. Cold Equipment (Below Ambient Temperature):
 - 1. Application requirements: Insulate the following cold equipment:
 - a. Refrigeration equipment, including chillers, tanks and pumps.
 - b. Drip pans under chilled equipment.
 - c. Cold and chilled water pumps.
 - d. Pneumatic water tanks.
 - 2. Insulate each item of equipment specified above with one of the following types and thicknesses of insulation:
 - a. Fiberglass: 2" thick for cold surfaces above 35°F and 3" thick for surfaces 35°F and lower.
- B. Hot Equipment (Above Ambient Temperature):
 - 1. Application Requirements: Insulate the following hot equipment:
 - a. Boilers (not pre-insulated at factory).
 - b. Water heaters.
 - c. Hot water expansion tanks.
 - d. Hot water pumps.
 - 2. Insulate each item of equipment specified above with one of the following types and thicknesses of insulation.
 - a. Fiberglass: 2" thick, except 3" thick for low-pressure boilers and steam-jacketed heat exchangers.
- C. Breechings and Stacks:
 - 1. Application Requirements: Insulate the following breechings and stacks:
 - a. Breechings between heating equipment outlet and stack or chimney connection, except for double wall or factory insulated breechings.

3.05 INSTALLATION OF PIPING INSULATION

- A. General: Install insulation products in accordance with manufacturer's written instructions, and in accordance with recognized industry practices to ensure that insulation serves its intended purpose.
- B. Install insulation on pipe systems subsequent to installation of heat tracing, painting, testing, and acceptance of tests.
- C. Install insulation materials with smooth and even surfaces. Insulated each continuous run of piping with full-length units of insulation, with a single cut piece to complete run. Do not use cut pieces or scraps abutting each other.
- D. Clean and dry pipe surfaces prior to insulating. Butt insulation joints firmly together to ensure a complete and tight fit over surfaces to be covered.
- E. Maintain integrity of vapor barrier jackets on pipe insulation, and protect to prevent puncture or other damage.
- F. Cover valves, fittings and similar items in each piping system with equivalent thickness and composition of insulation as applied to adjoining pipe run. Install factory molded, precut or job fabricated units (at Installer's option) except where specific form or type is indicated.
- G. Extend piping insulation without interruption through walls, floors and similar piping penetrations, except where otherwise indicated.

- H. Butt pipe insulation against pipe hanger insulation inserts. For hot pipes, apply 3" wide vapor barrier tape or band over the butt joints. For cold piping apply wet coat of vapor barrier lap cement on butt joints and seal joints with 3" wide vapor barrier tape or band.

3.06 INSTALLATION OF DUCTWORK INSULATION

- A. General: Install insulation products in accordance with manufacturer's written instructions, and in accordance with recognized industry practices to ensure that insulation serves its intended purpose.
- B. Install insulation materials with smooth and even surfaces.
- C. Clean and dry ductwork prior to insulating. Butt insulation joints firmly together to ensure complete and tight fit over surfaces to be covered.
- D. Maintain integrity of vapor barrier on ductwork insulation, and protect it to prevent puncture and other damage.
- E. Extend ductwork insulation without interruption through walls, floors and similar ductwork penetrations, except where otherwise indicated.
- F. Lined Ductwork: Except as otherwise indicated, omit insulation on ductwork where internal insulation or sound absorbing linings have been installed.
- G. Ductwork Exposed to Weather: Where external insulation has been specifically indicated, protect outdoor insulation from weather by installing outdoor protective finish or jacketing as recommended by manufacturer.
- H. Corner Angles: Except for oven and hood exhaust duct insulation, install corner angles on external corners of insulation on ductwork in exposed finished spaces before covering with jacketing.

3.07 INSTALLATION OF EQUIPMENT INSULATION

- A. General: Install equipment thermal insulation products in accordance with manufacturer's written instructions, and in compliance with recognized industry practices to ensure that insulation serves intended purpose.
- B. Install insulation materials with smooth and even surfaces and on clean and dry surfaces. Redo poorly fitted joints. Do not use mastic or joint sealer as filler for gaping joints and excessive voids resulting from poor workmanship.
- C. Maintain integrity of vapor-barrier on equipment insulation and protect it to prevent puncture and other damage.
- D. Do not apply insulation to equipment, breechings, or stacks while hot.
- E. Apply insulation using the staggered joint method for both single and double layer construction, where feasible. Apply each layer of insulation separately.
- F. Coat insulated surfaces with layer of insulating cement, troweled in workmanlike manner, leaving a smooth continuous surface. Fill in scored block, seams, chipped edges and depressions, and cover over wire netting and joints with cement of sufficient thickness to remove surface irregularities.
- G. Cover insulated surfaces with all-service jacketing neatly fitted and firmly secured. Lap seams at least 2". Apply over vapor barrier where applicable.
- H. Do not insulate hot water storage tank manholes, hand-holes, cleanouts, ASME stamp, and manufacturer's nameplate. Provide neatly beveled edge at interruptions of insulation.

- I. Provide removable insulation sections to cover parts of equipment which must be opened periodically for maintenance; include metal vessel covers, fasteners, flanges, frames and accessories.
- J. Equipment exposed to Weather: Protect outdoor insulation from weather by installation of weather-barrier mastic protective finish, or jacketing, as recommended by the manufacturer.

3.08 ACOUSTICAL INSTALLATION

- A. Install within confines of roof curbs for roof mounted air handlers and air conditioning units, and elsewhere as indicated on drawings
- B. Cut to fit snugly within curb and around duct at duct penetrations, 4" minimum thickness.

3.09 PROTECTION AND REPLACEMENT

- A. Replace damaged insulation which cannot be repaired satisfactorily, including units with vapor barrier damage and moisture saturated units.
- B. Protection: Insulation Installer shall advise Contractor of required protection for insulation work during remainder of construction period, to avoid damage and deterioration.

END OF SECTION

COMMISSIONING

PART 1 – GENERAL

1.1. RELATED DOCUMENTS

- A. Drawings and general provisions of the Contract, including General and Supplementary Conditions and Division 1 Specification Sections, apply to this Section.
- B. Owners Project Requirements.
- C. Basis of Design
- D. Contractor and Vendor field start-up reports.
- E. Contractor QA/QC Testing reports.
- F. Close-out documentation including O&M Manuals.
- G. Related Sections:
 - 1. Section 013300 "Submittals"
 - 2. Section 013515 "LEED Requirements"
 - 3. Section 019100 "Cx Requirements"
 - 4. Section 250800 "Commissioning Integrated Automation"
 - 5. Section 260800 "Electrical Systems Commissioning"
 - 6. Division 22 - "Plumbing"
 - 7. Division 23 - "Heating Ventilating and Air Conditioning"
 - 8. Division 26 - "Electrical"

1.2. SUMMARY

- A. This Section includes requirements for commissioning the HVAC system and its subsystems and equipment as required by LEED. This Section supplements the general requirements specified in Division 01 Section 019100 "Commissioning Requirements".

1.3. CONTRACTOR'S RESPONSIBILITIES

- A. The following responsibilities are in addition to those specified in Division 01 Section "General Commissioning Requirements." Refer to the project Commissioning Plan for more detailed descriptions of the Contractor's roles.
- B. Contractor:
 - 1. Attend procedures meeting for TAB Work.
 - 2. Certify that TAB Work is complete.
- C. Mechanical Contractor:
 - 1. Develop full startup and initial checkout plan using manufacturer's startup procedures and prefunctional checklists from Commissioning Authority for commissioned equipment. Submit to Commissioning Authority for review and approval prior to startup.
 - 2. Perform and clearly document completed startup and system operational checkout procedures, providing copy to Commissioning Authority.
 - 3. Attend TAB verification testing.
 - 4. Provide measuring instruments and logging devices to record test data, and data acquisition equipment to record data for the complete range of testing for the required test period.
 - 5. Participate in functional performance testing of HVAC equipment with Commissioning Authority.
- D. HVAC Instrumentation and Control Contractor
 - 1. Review control designs for compliance with the OPR and BoD, controllability with respect to actual equipment to be installed, and recommend adjustments to control designs and sequence of operation descriptions.
 - 2. Participate in functional performance testing of HVAC equipment with Commissioning Authority.
- E. TAB Contractor:
 - 1. Prepare a TAB agenda and send to the Commissioning Authority for review. Before developing TAB procedures verify the following:

- c. Accessibility of equipment and components required for TAB Work.
 - b. Adequate number and placement of duct balancing dampers to allow proper balancing while minimizing sound levels in occupied spaces.
 - C. Adequate number and placement of balancing valves to allow proper balancing and recording of water flow.
 - d. Adequate number and placement of test ports and test instrumentation to allow reading and compilation of system and equipment performance data needed to conduct both TAB and commissioning testing.
 - e. Air and water flow rates have been specified and compared to central equipment output capacities.
2. Additional Responsibilities: Participate in HVAC functional performance tests specified by the Commissioning Plan.
- F. Electrical Contractor:
- 1. With the Mechanical Contractor, coordinate installations and connections between and among electrical and HVAC systems, subsystems, and equipment.
 - 2. Fill out electrical connection portions of HVAC construction checklists.

PART 2 – PRODUCTS

2.1. FUNCTIONAL PERFORMANCE TESTING EQUIPMENT AND INSTRUMENTS

- A. Contractor shall provide all tools, instruments, laptop computers, PDAs, software programs and services required to perform system Functional Performance Testing procedures. This includes providing the connection to systems to be tested, operation of the test equipment & instrumentation and generating test results as required.

PART 3 – EXECUTION

3.1. TESTING PREPARATION

- A. Prerequisites for Testing, in addition to those listed in Section 019100 “Commissioning Requirements”
 - 1. TAB work is complete and a preliminary copy of the TAB report has been sent to the Commissioning Authority for review.
 - 2. The HVAC control system is operating as per the approved submittal with all applicable operating modes programmed.

3.2. FUNCTIONAL PERFORMANCE TESTING

- A. Test systems and intersystem performance after test checklists for systems, subsystems, and equipment have been approved.
- B. Perform tests using design conditions whenever possible.
 - 1. Simulate conditions by imposing an artificial load when it is not practical to test under design conditions and when written approval for simulated conditions is received from CxA. Before simulating conditions, calibrate testing instruments. Set and document simulated conditions and methods of simulation. After tests, return settings to normal operating conditions.
 - 2. Alter set points when simulating conditions is not practical.
- C. Scope of HVAC Contractor Testing:
 - 1. Testing scope shall include entire HVAC installation. It shall include measuring capacities and effectiveness of operational and control functions.
 - 2. Test all operating modes, interlocks, control responses, responses to abnormal or emergency conditions, and verify proper response of building automation system controllers and sensors.
- D. Detailed Testing Procedures: CxA, with HVAC Contractor, TAB Contractor, and HVAC Instrumentation and Control Contractor, shall prepare detailed testing plans, procedures, and checklists for HVAC systems, subsystems, and equipment.
- E. Deferred Testing:
 - 1. If tests cannot be completed because of a deficiency outside the scope of the HVAC system, the deficiency shall be documented and reported to Owner. Deficiencies shall be resolved and corrected by appropriate parties and test rescheduled.
 - 2. If the testing plan indicates specific seasonal testing, appropriate initial performance tests shall be completed and documented and additional tests scheduled.

END OF SECTION

ENERGY MANAGEMENT

PART 1 - GENERAL

1.01 RELATED DOCUMENTS

- A. Drawings and general provisions of Contract, including General and Supplementary conditions and Division-1 Specification sections, apply to work of this section.

1.02 DESCRIPTION OF WORK: Provide all work for the complete installation of automatic temperature controls.

- A. Work in this Section: Principal items include:
 1. Electronic and electric controls, includes sensors, switches, relays, control panels for instruments.
 2. Electric motors for air dampers, valves, etc.
 3. Local control panels.
 4. Adjustment and validation of control system. Instruction of Owner's representative on maintenance and operation of control equipment.
 5. Electric diagrams showing interlocks between equipment furnished under the other sections and control furnished herein.
 6. Direct digital control for systems.
 7. Wiring and Conduit: low voltage wire for the control system under Division 23, all low voltage control conduit, all required power wiring, high voltage wire and high voltage conduit under Division 26.
 8. Contractor shall install the latest version of DDC Control Software.

1.03 SYSTEM

- A. The Temperature Control System shall be installed as a installed project and shall consist of all sensors, actuators, direct digital controllers, supervisory controller, electrical low voltage (24 VAC) and line voltage control wiring for a complete and operating installation as specified herein. The system shall be a standard product with the manufacturer who will guarantee ongoing parts availability and factory trained field support for five (5) years after system acceptance.

1.04 RELATED SECTIONS

- A. Refer to Division 09 for patching and painting required for the control system installation. Not work of this section.
- B. Automatic dampers in ductwork, casings, etc. furnished and installed by the Mechanical Division under control people's supervision. The dampers shall be correctly installed so that they operate freely and close tightly. Provide and install blank off plates when the control application requires dampers smaller than duct size.
- C. Refer to Division-26 sections for the following work; not work of this section:
 1. Power supply wiring for power source to power connection on controls and/or unit control panels, including starters, disconnects, and required electrical devices, except where specified as furnished, or factory-installed, by manufacturer.

1.05 QUALITY ASSURANCE

- A. Codes and Standards:
 1. General: The publications listed below form a part of this specification to the extent applicable:
ASHRAE Handbook of Fundamentals, Latest Edition.

EIA	Electrical Characteristics of Balanced Voltage Digital Interface Circuits;
RS-485.	
NEMA	Enclosures for Electrical Equipment (1000 volts maximum); 250-1979
NFPA 70	National Electrical Code; 1981
NFPA 90A	Air Conditioning and Ventilation Systems; 1981

1.06 SUBMITTALS

- A. Submit installation drawings, sequences of operation and catalog cut sheets for each device of the proposed system prior to installation for engineer's approval. The drawings shall include the location and intercommunication of all stand-alone and subordinate control panels; the schematic diagrams, of the controlled equipment with sensors and actuators shown interconnected to the system controllers; and logic diagrams that depict the sequence of operation.
- B. After completion of the installation and commissioning of the system including final adjustments, a full set of as-built documentation shall be turned over to the Owner. The as-builts shall include one (1) set of reproducible drawings and two (2) copies of the database on flexible or removable hard disk for each stand-alone controller and the supervisory computer.
 - 1. As-built documentation shall include diagrammatic layouts of the automatic control systems specified herein. Layouts shall show all control equipment, and the function of each item shall be indicated for the different seasons, Layouts shall be located in plastic protective folder and placed in the control panels.
 - 2. All Drawings shall be accompanied with a complete description of sequence of operation. Each control element mentioned in the sequence description shall be identified with the same mark as shown- on the control diagram.
- C. Submittal of Materials:
 - 1. Material submittals shall be manufacturers prepared catalog cuts indicating type, size and technical details.
 - 2. Reference catalog cuts to the applicable specification article (e.g. 2.02A).
 - 3. Catalog cuts shall be submitted in complete groups of manufacturer's material.
 - 4. Partial submittals of groups or systems are not acceptable.
 - 5. Verify that the submittal has been reviewed in detail and is in fact the Contractor's choice of materials.
- D. Upon receipt of contract and prior to the delivery of parts, submit eight copies of the following drawings:
 - 1. Submit eight copies of schematic drawings showing the respective locations of components, as applicable and interconnecting wiring between all devices. Also all field terminal and sensing devices. Also all field terminal and sensing devices shall be listed by function and point number and shall display interconnecting wiring and terminals of controlled systems and devices.
- E. Submit eight copies of schematic drawings showing electric connection details for actuators, transducers, and other electric components. All connections shall be labeled to coordinate with the description of operation, including descriptions to indicate action of components, normal positions, spring ranges, etc.

1.07 MANUFACTURERS

- A. Carrier I-VU Controls. No substitutions will be accepted.
- B. Controls installation will be by Russell Sigler, Inc. Controls Group Certified Installer, Brea, California.

1.08 WARRANTY

- A. Provide all labor, material and equipment necessary to maintain beneficial performance of the entire Building Automation System for a period of one (1) year after acceptance of the system, or parts thereof, by an authorized representative of the Owner. Any defects in workmanship or material during the warranty period shall be promptly corrected by the Contractor at no charge to the Owner. All work shall be accomplished during normal working hours, Monday through Friday excluding legal holidays. Precaution shall be taken to minimize disruption of facility operations.
- B. A prepaid Warranty Service Agreement shall be turned over to the Owner at the time of the acceptance test as a prerequisite of system acceptance. The contract shall include the terms and conditions stated herein.
- C. Service work shall be performed by service personnel in the direct employ of the control contractors. The service technicians shall be factory trained and certified by the manufacturer to be competent in all aspects of the installed system. The technician shall have a working knowledge of calibration techniques, preventive maintenance, troubleshooting, software diagnostics and microprocessor repair.

- D. Provide preventive maintenance at one (1) month intervals such that one twelfth of the system is tested and re-commissioned if necessary at each monthly inspection. An Owner's representative shall certify that the monthly test has been conducted and the control system is functioning properly. A log of tasks performed at each test shall be maintained by the controls contractor and signed by the Owner as evidence of satisfactory completion of the Warranty Service Agreement. The log shall be retained on site and available for review by authorized personnel.
- E. System modifications shall be incorporated into the as-built documentation and/or operators and maintenance manuals when operating parameters, control point settings or control strategies are changed. System modifications made by the user of the controls contractor shall have both parties' approvals in order to maintain the Warranty Service Agreement. All database changes shall be saved on disk for backup to the system.
- F. Software upgrade program shall be implemented on the anniversary or anniversaries of the warranty period. The upgrade shall provide all enhancements offered by the manufacturer for programs in the accepted systems.
- G. System enhancements beyond the scope of the project shall be field upgradable with pull out/plug-in ease. Provided at reasonable value added cost these upgrades may be purchased at the Owner's option.

PART 2 - PRODUCTS

2.01 COMMUNICATION

- A. Control products, communication media, connectors, repeaters, hubs, and routers shall comprise a BACnet internetwork. Controller and operator interface communication shall conform to ANSI/ASHRAE Standard 135-2004, BACnet.
- B. Install new wiring and network devices as required to provide a complete and workable control network.
- C. Each controller shall have a communication port for temporary connection to a laptop computer or other operator interface. Connection shall support memory downloads and other commissioning and troubleshooting operations.
- D. Internetwork operator interface and value passing shall be transparent to internetwork architecture.
 - 1. An operator interface connected to a controller shall allow the operator to interface with each internetwork controller as if directly connected. Controller information such as data and status shall be viewable and editable from each internetwork controller.
 - 2. Inputs, outputs, and control variables used to integrate control strategies across multiple controllers shall be readable by each controller on the internetwork. An authorized operator shall be able to edit cross-controller links by typing a standard object address or by using a point-and-click interface.
- E. Controllers with real-time clocks shall use the BACnet Time Synchronization service. System shall automatically synchronize system clocks daily from an operator-designated controller via the internetwork. If applicable, system shall automatically adjust for daylight saving and standard time.

2.02 FIELD INSTALLED SENSORS

- A. Temperature Sensors
 - 1. Type. Temperature sensors shall be nominal 10K ohm thermistor type.
 - 2. Duct Sensors. Duct sensors shall be single point.
 - 3. Space Sensors. Space sensors shall have setpoint adjustment, override switch, display, and communication port as shown.
- B. Status Indication
 - 1. Status indication for fans shall be provided by a current sensing sensor. The sensor shall be installed at the motor starter or motor to provide load indication. The unit shall consist of a current transformer, a solid state current sensing circuit (with adjustable set point) and a solid state switch. A red light emitting diode (LED) shall indicate the on off status of the unit. The switch shall provide a N.O. contact for wiring back to the Field Installed Controller.

2.03 CONTROLLER SOFTWARE

- A. Building and energy management application software shall reside and operate in system controllers. Applications shall be configurable through the operator workstation, web browser interface, or engineering workstation.
- B. Memory and System Time. All controllers shall have a Non-Volatile Memory providing indefinite storage of application and configuration data. The system must have an ability to maintain time, and automatically correct for daylight savings time and leap year adjustments. In the event of power failure or user generated power cycle, all system components must automatically updated with current time and date from a network Time Sync device. The controller shall also have the capability of changing occupancy mode by reading a set of discrete, dry contacts controlled by an external time clock.
- C. Stand alone capability. All controllers shall be capable of providing all control functions of the HVAC system without the use of a computer. The controllers shall include the inherent capability to access the system control selections as well as to monitor system performance by means of a communicating network with a PC and EMS software program.
- D. Remote Communication. System shall automatically contact operator workstation or server on receipt of critical alarms.
- E. PID Control. System shall provide direct- and reverse-acting PID (proportional-integral-derivative) algorithms. Each algorithm shall have anti-windup and selectable controlled variable, setpoint, and PID gains. Each algorithm shall calculate a time-varying analog value that can be used to position an output or to stage a series of outputs.
- F. Staggered Start. System shall stagger controlled equipment restart after power outage. Operator shall be able to adjust equipment restart order and time delay between equipment restarts.
- G. Anti-Short Cycling. Binary output objects shall be protected from short cycling by means of preconfigured minimum on-time and off-time settings, customized for the specific requirements of the application.
- H. On and Off Control with Differential. System shall provide direct- and reverse-acting on and off algorithms with adjustable differential to cycle a binary output based on a controlled variable and setpoint.

2.04 CONTROLLERS

- A. General. The control system shall be available as a complete package with the required input sensors and devices readily available. Provide Building Controllers (BC), Advanced Application Controllers (AAC), Application Specific Controllers (ASC), and Sensors (SEN) as required to achieve performance specified in Paragraph 2.4.
- B. Every device in the system which executes control logic and directly controls HVAC equipment must conform to a standard BACnet Device profile as specified in ANSI/ASHRAE 135-2004, BACnet Annex L. unless otherwise specified.
- C. BACnet.
 - 1. Building Controllers (BCs). Each BC shall conform to BACnet Building Controller (B-BC) device profile as specified in ANSI/ASHRAE 135-2004, BACnet Annex L and shall be listed as a certified B-BC in the BACnet Testing Laboratories (BTL) Product Listing.
 - 2. Advanced Application Controllers (AACs). Each AAC shall conform to BACnet Advanced Application Controller (B-AAC) device profile as specified in ANSI/ASHRAE 135-2004, BACnet Annex L and shall be listed as a certified B-AAC in the BACnet Testing Laboratories (BTL) Product Listing.
 - 3. Application Specific Controllers (ASCs). Each ASC shall conform to BACnet Application Specific Controller (B-ASC) device profile as specified in ANSI/ASHRAE 135-2004, BACnet Annex L and shall be listed as a certified B-ASC in the BACnet Testing Laboratories (BTL) Product Listing.
 - 4. BACnet Communication.
 - a. Each BC shall reside on or be connected to a BACnet network using ISO 8802-3 (Ethernet) Data Link/Physical layer protocol and BACnet/IP addressing.
 - b. BACnet routing shall be performed by BCs or other BACnet device routers as necessary to connect BCs to networks of AACs and ASCs.
 - c. Each AAC shall reside on a BACnet network using ISO 8802-3 (Ethernet) Data Link/Physical layer protocol with BACnet/IP addressing, or it shall reside on a BACnet network using the MS/TP Data Link/Physical layer protocol.
 - d. Each ASC shall reside on a BACnet network using the MS/TP Data Link/Physical layer protocol.
- D. Communication.
 - 1. Service Port. Each controller shall provide a service communication port for connection to a Portable Operator's Terminal. Connection shall be extended to space temperature sensor ports where shown on drawings.

2. Signal Management. BC and ASC operating systems shall manage input and output communication signals to allow distributed controllers to share real and virtual object information and to allow for central monitoring and alarms.
 3. Data Sharing. Each BC and AAC shall share data as required with each networked BC and AAC.
 4. Stand-Alone Operation. Each piece of equipment shall be controlled by a single controller to provide stand-alone control in the event of communication failure. All I/O points specified for a piece of equipment shall be integral to its controller. Provide stable and reliable stand-alone control using default values or other method for values normally read over the network.
- E. Environment. Controller hardware shall be suitable for anticipated ambient conditions.
1. Controllers used outdoors or in wet ambient conditions shall be mounted in waterproof enclosures and shall be rated for operation at -29°C to 60°C (-20°F to 140°F).
 2. Controllers used in conditioned space shall be mounted in dust-protective enclosures and shall be rated for operation at 0°C to 50°C (32°F to 120°F).
- F. Keypad. Where specified provide a local keypad and display for each BC and ASC. Operator shall be able to use keypad to view and edit data. Keypad and display shall require password to prevent unauthorized use. If the manufacturer does not normally provide a keypad and display for each BC and ASC, provide the software and any interface cabling needed to use a laptop computer as a Portable Operator's Terminal for the system.
- G. Serviceability.
1. Controllers shall have diagnostic LEDs for power, communication, and processor.
 2. Wires shall be connected to a field-removable modular terminal strip or to a termination card connected by a ribbon cable.
 3. All controllers in the system shall continually check its processor and memory circuit status and shall generate an alarm on abnormal operation. System shall continuously check controller network and generate alarm for each controller that fails to respond.
- H. Memory.
1. Controller memory shall support operating system, database, and programming requirements.
 2. Each controller in the system shall use nonvolatile memory providing indefinite storage of BIOS, application programming, and all configuration data in the event of power loss.
- I. Immunity to Power and Noise. Controllers shall be able to operate at 90% to 110% of nominal voltage rating and shall perform an orderly shutdown below 80% nominal voltage. Operation shall be protected against electrical noise of 5 to 120 Hz and from keyed radios up to 5 W at 1 m (3 ft).
- J. Rooftop Unit Controller (RTC). Defined as Application Specific Controllers (ASC), shall control all associated HVAC Constant Volume rooftop equipment functions, this operation shall be provided when operating within a zoning system application, as specified for an air source control, in Paragraph 2.4 or in a stand-alone mode. The resident algorithms shall use error reduction logic as designated in ASHRAE standard 90.1 to provide temperature control and energy usage.
1. Capacity control shall be based on the use of a conventional thermostat, or programmable thermostat, or alternatively, a constant volume unit may utilize its own internal time clock and setpoints (cooling and heating) coupled with a room (wired or network communicating) sensor for capacity control. The controls shall provide separate occupied and unoccupied cooling and heating setpoints – except if a conventional thermostat is used.
 2. RTC shall feature and maintain a 365-day Real-Time Clock/Calendar with holiday functions.
 3. RTC shall be capable of stand-alone or networked operation.
 4. In the stand alone mode, each RTC shall establish occupancy scheduling based on its own local occupancy schedule, the closure of a contact connected to an external time clock or EMS system, or by a timed override request (1 to 24 hours) through its space temperature sensor override button.
 5. When networked, RTC occupancy may be established by user interface or occupancy signal from other controller located in network.
 6. RTC shall utilize fan control, 2 stages of cooling, and up to 3 stages of heating to maintain zone temperature at setpoint.
 7. RTC shall provide analog output signal for economizer control.
- K. Integration to Lighting Panel(s)
1. Control Contractor Provide a Carrier I-V Link for Intergration BACnet/IP.
 2. Lighting panel(s) provided and installed by Division 26 for monitoring and controlling of lighting and operation oriented graphic user interface.

3. Lighting panels provided will support BACnet/IP. Any gateways or additional cards required will be provided and installed by Division 26.
4. Refer to Electrical and Mechanical drawings for points will be integrated to the Carrier I-Vu web server BACnet/IP.

2.05 SYSTEM INTERFACE (District Wide Web Server Existing)

- A. Description. The control system shall be as shown and consist of a high-speed, peer-to-peer network of DDC controllers and a stand alone web server operator interface. Depict each mechanical system and building floor plan by a point-and-click graphic. A web server shall gather data from this system and generate web pages accessible through a conventional web browser on each PC connected to the network. Operators shall be able to perform all normal operator functions through the web browser interface. Operators with sufficient access level shall have an ability to make changes to all system and equipment graphics in the web server in addition to having full DDC system access to make configuration changes to the control system. Any tools required for making graphic changes shall be provided with web server.
- B. Operator Interface. Operators shall be able to access all necessary operational information in the DDC system via client computer utilizing IE web browser. Client computer and IE web browsing software shall not be furnished under this section.
 1. Web server shall connect via the LAN and be able to simultaneously serve up controller information to multiple operators connected via LAN with IE web browsers. Each client web browser connected to server shall be able to access all system information.
 2. Web server shall be compatible with Wireless Access Protocol (WAP) enabled cellular telephone or personal digital assistant (PDA). The PDA/WAP interface may be text-based and shall provide a summary of the most important data.
 3. With the use of a remote SMTP email server the operators interface web server shall be able to notify personnel of an alarm or record information about an alarm in the DDC system.
- C. Web Server Hardware. Furnish one compact web server with Ethernet port for LAN or direct operator client computer access. The web server shall be capable of communicating to the peer to peer DDC controller network. Any required installation or commissioning software shall be pre-installed on the web server. Installation or commissioning of the web server shall be done through a client computer with a standard web browser.
- D. Communication. Web server or workstation and controllers shall communicate using BACnet protocol. Web server or workstation and control network backbone shall communicate using ISO 8802-3 (Ethernet) Data Link/Physical layer protocol and BACnet/IP addressing as specified in ANSI/ASHRAE 135-2004, BACnet Annex J.
- E. Operator Functions. Operator interface shall allow each authorized operator to execute the following functions as a minimum:
 1. Log In and Log Out. System shall require user name and password to log in to operator interface.
 2. Point-and-click Navigation. Operator interface shall be graphically based and shall allow operators to access graphics for equipment and geographic areas using point-and-click navigation.
 3. View and Adjust Equipment Properties. Operators shall be able to view controlled equipment status and to adjust operating parameters such as set points, PID gains, on and off controls, and sensor calibration.
 4. View and Adjust Operating Schedules. Operators shall be able to view scheduled operating hours of each schedulable piece of equipment on a weekly or monthly calendar-based graphical schedule display, to select and adjust each schedule and time period, and to simultaneously schedule related equipment. System shall clearly show exception schedules and holidays on the schedule display.
 5. View and Respond to Alarms. Operators shall be able to view a list of currently active system alarms, to acknowledge each alarm, and to clear (delete) unneeded alarms. Remote users shall be able to receive alarms via emails or cell phone text messages.
 6. View and Configure Trends. Operators shall be able to view a trend graph of each trended point and to edit graph configuration to display a specific time period or data range. Operator shall be able to create custom trend graphs to display on the same page data from multiple trended points.
 7. View and Configure Reports. Operators shall be able to run preconfigured reports, to view report results, and to customize report configuration to show data of interest.
 8. Manage Control System Hardware. Operators shall be able to view controller status, to restart (reboot) each controller, and to download new control software to each controller.
 9. Manage Operator Access. Typically, only a few operators are authorized to manage operator access. Authorized operators shall be able to view a list of operators with system access and of functions they can perform while

logged in. Operators shall be able to add operators, to delete operators, and to edit operator function authorization. Operator shall be able to authorize each operator function separately.

F. System Software.

1. Operating System and required software. Web server operator interface shall be a self contained web server without the need for any type of maintenance. Any required operating system or software shall be factory loaded and maintenance free.
2. System Graphics. Operator interface shall be graphical and shall include at least one graphic per piece of equipment or occupied zone, graphics for each chilled water and hot water system, and graphics that summarize conditions on each floor of each building included in this contract. Indicate thermal comfort on floor plan summary graphics using dynamic colors to represent zone temperature relative to zone setpoint.
 - a. Functionality. Graphics shall allow operator to monitor system status, to view a summary of the most important data for each controlled zone or piece of equipment, to use point-and-click navigation between zones or equipment, and to edit setpoints and other specified parameters.
 - b. Animation. Graphics shall be able to animate by displaying different image files for changed object status.
 - c. Alarm Indication. Indicate areas or equipment in an alarm condition using color or other visual indicator.
 - d. Format. Graphics shall be saved in an industry-standard format such as BMP, JPEG, PNG, or GIF. Web-based system graphics shall be viewable on browsers compatible with World Wide Web Consortium browser standards. Web graphic format shall require no plug-in (such as HTML and JavaScript) or shall only require widely available no-cost plug-ins (such as Active-X and Macromedia Flash).

G. System Tools. System shall provide the following functionality to authorized operators as an integral part of the operator interface or as stand-alone software programs. If furnished as part of the interface, the tool shall be available from each workstation or web browser interface. If furnished as a stand-alone program, software shall be installable on standard Windows compatible PCs with no limit on the number of copies that can be installed under the system license.

1. Automatic System Database Configuration. Each web server shall store internally store a copy of the current system database, including controller firmware and software. Stored database shall be automatically updated with each system configuration or controller firmware or software change.
2. Controller Memory Download. Operators shall be able to download memory from the system database to each controller.
3. System Configuration. Operators shall be able to configure the system.
4. Online Help. Context-sensitive online help for each tool shall assist operators in operating and editing the system.
5. Security. System shall require a user name and password to view, edit, add, or delete data.
 - a. Operator Access. Each user name and password combination shall define accessible viewing, editing, adding, and deleting functions in each system application, editor, and object.
 - b. Automatic Log Out. Automatically log out each operator if no keyboard or mouse activity is detected. Operators shall be able to adjust automatic log out delay.
 - c. Encrypted Security Data. Store system security data including operator passwords in an encrypted format. System shall not display operator passwords.
6. System Diagnostics. System shall automatically monitor controller and I/O point operation. System shall annunciate controller failure and I/O point locking (manual overriding to a fixed value).
7. Alarm Processing. System input and status objects shall be configurable to alarm on departing from and on returning to normal state. Operator shall be able to enable or disable each alarm and to configure alarm limits, alarm limit differentials, alarm states, and alarm reactions for each system object. Configure and enable alarm points as specified in Points List. Alarms shall be BACnet alarm objects and shall use BACnet alarm services.
8. Alarm Messages. Alarm messages shall use an English language descriptor without acronyms or mnemonics to describe alarm source, location, and nature.
9. Alarm Reactions. Operator shall be able to configure (by object) actions workstation or web server shall initiate on receipt of each alarm. As a minimum, workstation or web server shall be able to log, print, start programs, display messages, send e-mail, send page, and audibly annunciate.
10. Alarm Maintenance. Operators shall be able to view system alarms and changes of state chronologically, to acknowledge and delete alarms, and to archive closed alarms to the workstation or web server from each workstation or web browser interface.
11. Trend Configuration. Operator shall be able to configure trend sample or change of value (COV) interval, start time, and stop time for each system data object and shall be able to retrieve data for use in spreadsheets and standard database programs. Controller shall sample and store trend data and shall be able to archive data to the hard disk. Configure trends as specified in Points List. Trends shall be BACnet trend objects.
12. Object and Property Status and Control. Operator shall be able to view, and to edit if applicable, the status of each system object and property by menu, on graphics.

13. Reports and Logs. Operator shall be able to select, to modify, to create, and to print reports and logs. Operator shall be able to store report data in a format accessible by standard spreadsheet and word processing programs.
14. Standard Reports. Furnish the following standard system reports:
 - a. Reports shall be filtered based upon the selected equipment
 - b. Alarm Reports
 - 1) Alarm Summary - Current alarms
 - 2) Alarm Sources – List of equipment and associated alarm conditions
 - 3) Alarm Actions – Configured alarm actions such as e-mail and alarm pop-up
 - c. Schedule Reports
 - 1) Effective Schedules – Displays effective schedules for each equipment
 - 2) Schedule Instances – Displays all schedules entered
 - d. Security Reports – Maintains audit of all actions taken through user interface
 - e. Commissioning Reports – Provide equipment checkout status and notes
 - f. Equipment Reports – Provide reports showing trended points and available network points
15. Custom Reports. Operator shall be able to create custom reports that retrieve data, including archived trend data, from the system, that analyze data using common algebraic calculations, and that present results in tabular or graphical format. Reports shall be launched from the operator interface.
16. Graphics Generation. Graphically based tools and documentation shall allow Operator to edit system graphics, to create graphics, and to integrate graphics into the system. Operator shall be able to add analog and binary values, dynamic text, static text, and animation files to a background graphic using a mouse.
17. Graphics Library. Complete library of standard HVAC equipment graphics shall include equipment such as chillers, boilers, air handlers, terminals, fan coils, and unit ventilators. Library shall include standard symbols for other equipment including fans, pumps, coils, valves, piping, dampers, and ductwork. Library graphic file format shall be compatible with graphics generation tools.

PART 3 - EXECUTION

3.01 GENERAL

- A. All system components and appurtenances shall be installed in accordance with the manufacturer's instructions and requirements. All necessary interconnections, services and adjustments required for a complete and operable system, shall be provided by this contractor who shall be a Carrier certified installer of the systems herein.

3.02 INSTALLATION

A. GENERAL

1. Electric Wiring: This contractor is responsible for all electrical installation and wiring for a fully operational Building Control System as shown on the drawings and shall include all items not shown on the electrical plans or required as per the electrical specifications. Perform all electrical installation in accordance with local and national electrical codes. Plenum wire may be used in ceilings where anchored support is provided every 10 feet.
2. Provide shields as required by equipment manufacturer.

3.03 PERMITS AND FEES

- A. This contractor shall secure and pay for all necessary permits, licenses and inspections as required by federal, state or local law. This includes providing required notices, plans, licenses, and fees, obtaining any necessary approvals from authorities having jurisdiction, and delivering any certificates of inspection as may be required. No work is to proceed until all proper certificates and licenses are obtained and posted.

3.04 CLEAN-UP

- A. This contractor shall clean up regularly in order to maintain clean site conditions. In general, clean-up programs shall be scheduled by contractor at least once per week; however, the contractor shall clean up more often if required to meet OSHA standards.
- B. This contractor is responsible for coordinating the work with other trades so as to eliminate unnecessary cutting and patching.

3.05 EQUIPMENT INSTALLATION

A. Space Thermostat and Sensor Locations: In general, locate thermostats and sensors for room control immediately inside door, next to light switch at approximately 48 inches from floor. Coordinate thermostat locations with General Contractor and approval by Engineer.

B. Local Control Panels: Mount all local control panels as indicated on the control drawings.

3.06 CUTTING AND PATCHING

A. This contractor is responsible for coordinating the work with other trades so as to eliminate unnecessary cutting and patching.

3.07 EQUIPMENT INSTALLATION

A. Space Thermostat and Sensor Locations: In general, locate thermostats and sensors for room control immediately inside door, above light switch at approximately 60 inches from floor. Coordinate thermostat locations with General Contractor and approval by Engineer.

B. Local Control Panels: Mount all local control panels as indicated on the control drawings.

3.08 OWNER TRAINING

A. Provide classroom training for 2 owner technicians, classes to include i-VU-Standard and Plus, i-VU-Open VVT, and i-VU-Advanced Graphics, total of 32 hours per student. Owner's representatives shall be provided a booklet showing the system layout, components, and operation and maintenance data.

B. Training to include.

1. Explanation of drawings and diagrams.
2. Walk-thru of jobsite to locate control components
3. Overview of operation and maintenance features.
 - a. System front end operation (where applicable)

C. Manufacturer will operate a free 40 hour a week customer support hotline for additional user support services that are required within the first 12 months after installation is accepted by Owner's Representative.

END OF SECTION

SECTION 23 11 23

FACILITY NATURAL-GAS PIPING

PART1 GENERAL

1.01 SECTION INCLUDES

- A. This Section includes distribution piping systems for natural gas and manufactured gas within the building and extending from the point of delivery to the building to the connections with gas utilization devices. Piping materials and equipment specified in this Section include:
 - 1. Pipes, fittings, and specialties;
 - 2. Special duty valves.
- B. This Section does not apply to LP-gas piping; industrial gas applications using such gases as acetylene and acetylenic compounds, hydrogen, ammonia, carbon monoxide, oxygen and nitrogen; gas piping, meters, gas pressure regulators and other appurtenances used by the serving gas supplier in distribution of gas.
- C. Natural gas yard piping is not included in this section.
- D. Gas pressures for systems specified in this section are limited to 5 psig, unless otherwise specified.
- E. Products not furnished under this Section include gas meters which will be provided by the utility company, to the site, ready for installation.

1.02 RELATED SECTIONS:

- A. The following Sections contain requirements that relate to this Section:
 - 1. Division 33 Section "Natural Gas Yard Piping" for fuel gas service piping which is underground, outside the building, and connecting the "Gas Distribution Piping" to public utilities (or connecting groups of buildings on the same site).
 - 2. Division 02 "Structural Excavation and Backfill" for trenching and backfilling for installation of gas piping.
 - 3. Division 23 Section "Mechanical Identification" for labeling and identification of gas piping systems.

1.03 DEFINITIONS

- A. Pipe sizes used in this Specification are Nominal Pipe Size (NPS).
- B. Gas Distribution Piping: A pipe within the building which conveys gas from the point of delivery to the points of usage.
- C. Gas Yard Piping: That portion of gas distribution system which is underground.
- D. Gas Service Piping: The pipe from the gas main or other source of supply including the meter, regulating valve, or service valve to the gas distribution system and/or gas yard piping system being served.
- E. Point of Delivery is the outlet of the service meter assembly, or the outlet of the service regulator (service shutoff valve when no meter is provided).

1.04 SUBMITIALS

- A. Product data for each gas piping specialty and special duty valves. Include rated capacities of selected models, furnished specialties and accessories, and installation instructions.
- B. Maintenance data for gas specialties and special duty valves, for inclusion in operating and maintenance manual specified in Division 01 and Division-23 Section "Common Work Results for HVAC."

- C. Test reports specified in Part 3. Submit for inclusion in operating and maintenance manual.

1.05 QUALITY ASSURANCE

- A. Installation Qualifications: Installation and replacement of gas piping, gas utilization equipment or accessories, and repair and servicing of equipment shall be performed only by a qualified installer. The term qualified is defined as experienced in such work (experienced shall mean having a minimum of 5 previous projects similar in size and scope to this project), familiar with precautions required, and has complied with the requirements of the authority having jurisdiction. Upon request, submit evidence of such qualifications to the Architect.
- B. Qualifications for Welding Processes and Operators: Comply with the requirements of ASME Boiler and Pressure Vessel Code, "Welding and Brazing Qualification."
- C. Regulatory Requirements: Comply with the requirements of the following codes:
 - 1. NFPA 54 - National Fuel Gas Code, for gas piping materials and components, gas piping installations, and inspection, testing, and purging of gas piping systems.
 - 2. California Plumbing Code (CPC).

1.06 SEQUENCING AND SCHEDULING

- A. Notification of Interruption of Service: Except in the case of an emergency, notify all affected users when the gas supply is to be turned off, after approval in writing by the Owner's Representative a minimum of 48 hours beforehand.
- B. Work Interruptions: When interruptions in work occur while repairs or alterations are being made to an existing piping system, leave the system in safe condition.
- C. Coordinate the installation of pipe sleeves for wall penetrations.

1.07 EXTRA MATERIALS

- A. Valve wrenches: Furnish to Owner, with receipt, 2 valve wrenches for each type of gas valve installed, requiring same.

PART 2 PRODUCTS

2.01 MANUFACTURERS

- A. Manufacturer: Subject to compliance with requirements, provide gas piping system products from one of the following:
 - 1. Gas service cocks: Semi-steel 175 pound with tapered bronze plug and bolted yoke. Furnish one operating wrench for each valve.
 - Powell Fig. 2200 & 2201
 - Nordstrom Fig. 142 & 143
 - Walworth Fig. 1796 & 1797F
 - Homestead Fig. 611 & 612
 - 2. Gas valves at equipment: All bronze, flathead screwed gas cocks.
 - Powell Fig. 947
 - Crane Fig. 270
 - Healey Fig. 20F
 - Walworth Fig. 591

2.02 PIPE AND TUBING MATERIALS

- A. General: Refer to Part 3, Article "PIPE APPLICATIONS" for identification of systems where the below specified pipe and fitting materials are used.
- B. Steel Pipe: ASTM A 53, Schedule 40, seamless, black steel pipe, beveled ends.

2.03 FITTINGS

- A. Malleable-Iron Threaded Fittings: ANSI B16.3, Class 150, standard pattern, for threaded joints. Threads shall conform to ANSI B1.20.1.
 - 1. Joint compound or tape suitable for gas being handled.
- B. Steel Fittings: ASTM A 234, seamless or welded, for welded joints.
- C. Steel Flanges and Flanged Fittings: ANSI B16.5, including bolts, nuts, and gaskets of the following material group, end connection and facing:
 - 1. Material Group: 1.1
 - 2. End Connections: Butt,Welding.
 - 3. Facings: Raised face.

2.04 PIPING SPECIALTIES

- A. Unions: ANSI B16.39, Class 150, black malleable iron; female pattern; brass to iron seat; ground joint.
- B. Dielectric Unions: ANSI B16.39, Class 250; malleable iron and cast bronze; with threaded or soldered end connections suitable for pipe to be joined; designed to isolate galvanic and stray current corrosion.
- C. Protective Coating: When piping will be in contact with material or atmosphere exerting a corrosive action, pipe and fittings shall be factory-coated with polyethylene tape, having the following properties:
 - 1. overall thickness; 20 mils;
 - 2. synthetic adhesive;
 - 3. water vapor transmission rate, gallons per 100 square inch; 0.10 or less;
 - 4. water absorption, percent; 0.02 or less.
 - 5. Prime pipe and fittings with a compatible primer prior to application of tape.
- D. Painting: When piping will be installed exposed to view on the exterior (walls, overhangs, roofs, etc.) of a building, the piping shall be painted. See Section 09 90 00 Paint.

2.05 VALVES

- A. Gas Cocks 2 inch and Smaller: 150 psi WOG, bronze body, straightaway pattern, square head, threaded ends.
- B. Gas Cocks 2-1/2" Inch and Larger: MSS SP-78; 175 psi, lubricated plug type, semi-steel body, single gland, wrench operated, flanged ends.
- C. Ball Valves: Rated for 400 psi WOG pressure, two piece construction; with bronze body conforming to ASTM B62, Standard (or regular) post, chrome plated brass ball, replaceable "Teflon" or "TFE" seats and seals, blowout proof stem, and vinyl covered steel handle; with threaded ends.
- D. Solenoid Valves: aluminum body, 120 volts AC, 60 Hz, Class B continuous duty molded coil NEMA 4 coil enclosure; electrically opened/electrically closed; dual coils; normally closed; UL and FM approved and labeled.
- E. Gas Line Pressure Regulators: Single stage, steel jacketed, corrosion-resistant gas pressure regulators; with atmospheric vent, elevation compensator; with threaded ends for 2 inch and smaller, flanged ends for 2-1/2 inch and larger; for inlet and outlet gas pressures, specific gravity, and volume flow indicated.

PART 3 EXECUTION

3.01 PREPARATION

- A. Precautions: Before turning off the gas to the premises, or section of piping, turn off all equipment valves. Perform a leakage test as specified in "FIELD QUALITY CONTROL" below, to determine that all equipment is turned off in the piping section to be affected.
- B. Conform to the requirements in NFPA 54, for the prevention of accidental ignition.

3.02 PIPE APPLICATIONS

- A. Install steel pipe above ground with threaded joints and fittings for 2 inch and smaller, and with welded joints for 2-1/2" inch and larger.

3.03 PIPING INSTALLATIONS

- A. General: Conform to the requirements of NFPA 54- National Fuel Gas Code.
- B. Locations and Arrangements: Drawings (plans, schematics, and diagrams) indicate the general location and arrangement of piping systems. Design locations and arrangements of piping. Take into consideration pipe sizing, flow direction, slope of pipe, expansion, and other design considerations. So far as practical, install piping as indicated.
- C. Concealed Locations: Except as specified below, install concealed gas piping in an air-tight conduit constructed of Schedule 40, seamless black steel with welded joints. Vent conduit to the outside and terminate with a screened vent cap.
 - 1. Above-Ceiling Locations: Gas piping may be installed in accessible above-ceiling spaces (subject to the approval of the authority having jurisdiction), whether or not such spaces are used as a plenum. Valves shall not be located in such spaces.
 - 2. Piping in Partitions: Concealed piping shall not be located in solid partitions.
 - 3. Prohibited Locations: do not install gas piping in or through a circulating air duct, clothes chute, chimney or gas vent, ventilating duct, dumb waiter or elevator shaft.
- D. Install pipe sleeve seals at foundation penetrations.
- E. Seal pipe penetrations of fire barriers using fire barrier penetration sealers acceptable to the State Fire Marshal.
- F. Use fittings for all changes in direction and all branch connections.
 - 1. Weld-o-lets may be used in lieu of tees for branch connections two sizes or more, smaller than main.
 - 2. Mitered elbows or tees not permitted.
- G. Install exposed piping at right angles or parallel to building walls. Diagonal runs are not permitted, unless expressly indicated.
- H. Install piping free of sags or bends and with ample space between piping.
- I. Conceal all pipe installations in walls, pipe chases, utility spaces, above ceilings, below grade or floors, unless indicated to be exposed to view.
- J. Install piping tight to slabs, beams, joists, columns, walls, and other permanent elements of the building. Allow sufficient space above removable ceiling panels to allow for panel removal.
- K. Locate groups of pipes parallel to each other, spaced to permit servicing of valves.
- L. Install gas piping at a uniform grade of 1/4 inch in 15 feet, upward to risers, and from the risers to the meter, or service regulator when meter is not provided, or the equipment.
- M. Make reductions in pipe sizes using eccentric reducer fittings installed with the level side down.
- N. Connect branch outlet pipes from the top or sides of horizontal lines, not from the bottom.
- O. Hangers, supports, and anchors are specified in Division 22 Section "Hangers and Supports." Conform to the table below for maximum spacing of supports:

<u>SIZE (NPS)</u>	<u>SPACING IN FT.</u>	<u>MIN. ROD SIZE IN IN.</u>
1/2	5	3/8
3/4 to 1-1/4	6	3/8
1-1/2 to 3 {horizontal}	12	1/2
3-1/2 to 5 (vertical)	all sizes	every floor level

- P. Install unions in pipes 2 inches and smaller, adjacent to each valve, at final connections each piece of equipment, and elsewhere as indicated. Unions are not required on flanged devices.
- Q. Install dielectric unions where piping of dissimilar metals is joined.
- R. Install flanges on valves, apparatus, and equipment having 2-1/2 inch and larger connections.
- S. Install strainers on the supply side of each control valve, pressure reducing valve, pressure regulating valve, solenoid valve, and elsewhere as indicated.
- T. Install gravity dirt legs on supply side of equipment, accessible location, with a minimum four (4) inch down leg of same size supply pipe and terminate with threaded cap.
- U. Anchor piping to ensure proper direction of expansion and contraction. Install expansion loops and joints as indicated on the Drawings and specified in Division-23 Section " Common Work Results for HVAC."

3.04 PIPE JOINT CONSTRUCTION

- A. Welded Joints: Comply with the requirements in ASME Boiler and Pressure Vessel Code, Section IX.
- B. Threaded Joints: Conform to ANSI B1.20.1 tapered pipe threads for field cut threads. Join pipe, fittings, and valves as follows:
 1. Note the internal length of threads in fittings or valve ends, and proximity of internal seat or wall, to determine how far pipe should be threaded into joint. Refer to NFPA 54, for guide for number and length of threads for field threading steel pipe.
 2. Align threads at point of assembly.
 3. Apply appropriate tape or thread compound to the external pipe threads.
 4. Assemble joint to appropriate thread depth. When using a wrench on valves place the wrench on the valve end into which the pipe is being threaded.
 5. Damaged Threads: Do not use pipe with threads which are corroded, or damaged. If a weld opens during cutting or threading operations, that portion of pipe shall not be used.
- C. Flanged Joints: Align flange surfaces parallel. Assemble joints by sequencing bolt tightening to make initial contact of flanges and gaskets as flat and parallel as possible. Use suitable lubricants on bolt threads. Tighten bolts gradually and uniformly to appropriate torque specified by the bolt manufacturer.

3.05 VALVE APPLICATIONS

- A. General: The drawings indicate valve types, locations, and arrangements.
- B. Shut-off duty: Use gas cocks specified in Part 2 above.

3.06 VALVE INSTALLATIONS

- A. Install valves in accessible locations, protected from physical damage. Tag valves with a metal tag attached with a metal chain indicating the piping systems supplied.
- B. Install a gas cock upstream of each gas pressure regulator. Where two gas pressure regulators are installed in series in a single gas line, a manual valve is not required at the second regulator.

- C. Install ball valves in all locations required for quick emergency shut off.
- D. Install pressure relief or pressure limiting devices so they can be readily operated to determine if the valve is free; so they can be tested to determine the pressure at which they will operate; and examined for leakage when in the closed position.
- E. Install low pressure gas check in primary gas supply line to each laboratory room. Valve to be installed immediately downstream of manual emergency shut off valve.

3.07 TERMINAL EQUIPMENT CONNECTIONS

- A. Install gas cocks upstream and within 6 feet of gas appliance. Install a union or flanged connection downstream from the gas cock to permit removal of controls.
- B. Sediment Traps: Install a tee fitting with the bottom outlet plugged or capped as close to the inlet of the gas appliance as practical. Drip leg shall be a minimum of 3 pipe diameters in length.

3.08 ELECTRICAL BONDING AND GROUNDING

- A. Install above ground portions of gas piping systems, upstream from equipment shutoff valves electrically continuous and bonded to a grounding electrode in accordance with NFPA 70 - "National Electrical Code."
- B. Do not use gas piping as a grounding electrode.
- C. Conform to NFPA 70- "National Electrical Code," for electrical connections between wiring and electrically operated control devices.

3.09 FIELD QUALITY CONTROL

- A. Piping Tests: Inspect, test, and purge natural gas systems in accordance with NFPA 54, and local utility requirements.
- B. Prepare test reports and submit to the DSA Inspector.

END OF SECTION

SECTION 23 31 13

METAL DUCTS

PART 1 GENERAL

1.01 SECTION INCLUDES

- A. Rectangular and round metal ducts and plenums for heating, ventilating, and air conditioning system from minus 2" to plus 5" water gage.
- B. Section does not include laboratory exhaust system ductwork.

1.02 RELATED SECTIONS

- A. Refer to other Division-23 sections for exterior insulation of metal ductwork.
- B. Refer to other Division-23 sections for ductwork accessories
- C. Refer to other Division-23 sections for fans and air handling units
- D. Refer to other Division-23 sections for testing, adjusting and balancing of metal ductwork systems;

1.03 SUBMITTALS

- A. Product Data: Submit manufacturer's technical product data and installation instructions for metal ductwork materials and products including but not limited to flexible ductwork, acoustical flexible ductwork, pre manufactured ductwork, duct liner, duct sealant and duct liner adhesive.
- B. Record Drawings: At project closeout, submit record drawings of installed metal ductwork and ductwork products, in accordance with requirements of Division 01.
- C. Maintenance Data: Submit maintenance data and parts lists for metal ductwork materials and products. Include this data, product data, shop drawings, and record drawings in maintenance manual; in accordance with requirements of Division 01.
- D. Certified test data for the flexible duct.

1.04 QUALITY ASSURANCE

- A. Installer's Qualifications: Firm with at least 3 years of successful installation experience on projects with metal ductwork systems similar to that required for project.
- B. Codes and Standards:
 - 1. SMACNA Standards: Comply with SMACNA "HVAC Duct Construction Standards, Metal and Flexible" for fabrication and installation of metal ductwork.
 - 2. ASHRAE Standards: Comply with ASHRAE Handbook, Equipment Volume, Chapter 1 "Duct Construction", for fabrication and installation of metal ductwork.
 - 3. NFPA Compliance: Comply with NFPA 90A "Standard for the Installation of Air Conditioning and Ventilating Systems" and NFPA 90B "Standard for the Installation of Warm Air Heating and Air Conditioning Systems".
- C. Field Reference Manual: Have available for reference at project field office, copy of SMACNA "HVAC Duct Construction Standards, Metal and Flexible".

1.05 DELIVERY, STORAGE, AND HANDLING

- A. Delivery: Oil film on sheet metal should be removed before shipment to site. Contractor shall inspect ducts on site to confirm that no oil film is present. Remove any oil.

- B. Protection: Protect shop-fabricated and factory-fabricated ductwork, accessories and purchased products from damage during shipping, storage and handling. Prevent end damage and prevent dirt and moisture from entering ducts and fittings.
- C. Storage: Where possible, store ductwork inside and protect from weather. Where necessary to store outside, store above grade and enclose with waterproof wrapping.
- D. Cleaning: Dust and dirt on ducts shall be cleaned prior to installation, prior to substantial completion and prior to air circulation utilizing the ducts. HVAC system components or ductwork shall only be cleaned, coated, or have applied to its surface with disinfectants, pesticides or biocides that are registered and particularly labeled for use in HVAC systems by state and federal EPA.

PART 2 PRODUCTS

2.01 DUCTWORK MATERIALS

- A. Exposed Ductwork Materials: Where ductwork is indicated to be exposed to view in occupied spaces, provide materials which are free from visual imperfections including pitting, seam marks, roller marks, stains and discolorations, and other imperfections, including those which would impair painting.
- B. Sheet Metal: Except as otherwise indicated, fabricate ductwork from galvanized sheet steel complying with ASTM A527, lock forming quality, with G90 zinc coating in accordance with ASTM A525; and mill phosphatized for exposed locations.

2.02 MISCELLANEOUS DUCTWORK MATERIALS

- A. General: Provide miscellaneous materials and products of types and sizes indicated and, where not otherwise indicated, provide type and size required to comply with ductwork system requirements including proper connection of ductwork and equipment.
- B. Fittings: Provide radius type fittings fabricated of multiple sections with maximum 18-degree change of direction per section. Unless specifically detailed otherwise, use 45-degree laterals and 45-degree elbows for branch takeoff connections. Where 90-degree branches are indicated, provide conical type tees.
- C. Duct Liner:
 1. Rectangular ductwork: one and two inch thick fiberglass with approved fire resistant coating for erosion control, located as shown on the drawings and as outlined on table below. Apply to flat sheets with full coverage adhesive and insulation pins prior to fabrication of duct or fittings. Duct liner to be from R. J. Manville, Knauf, Owen-Corning, CertainTeed, Manson or an approved equal manufacturer.
 2. Circular Ductwork: Fiberglass duct liner manufactured to fit small and large radius round ducts. One inch thick with approved fire resistant coating for erosion control located as shown on the drawings. Apply to round ducts with full coverage adhesive prior to fabrication of ducts or fittings. Duct lining to be R. J. Manville, Spiracoustic Plus in ducts over 24" diameter and Schuler/Manville Permacote Spiracoustic in ducts under 24" diameter. Equal by Owen-Corning or CertainTeed. Duct sizes shown are net inside diameter. Increase duct sizes accordingly.
 3. Duct liner shall comply with Thermal Insulation Manufacturer's Association (TIMA) AHC-101; of thickness indicated above and on the drawings. Provide 2" thick above roofline, unless indicated otherwise.
 4. Duct insulation shall be installed on the exterior of ductwork. Duct lining for sound attenuation may be installed on the interior of ductwork. Lining material shall be certified to meet ASTM C1071 and ASTM C 1104 for surface erosion resistance and water vapor absorption. Refers to plan for lining requirement. (HPI EQ 2.0A)

- D. Duct Liner Adhesive: Comply with ASTM C 916 "Specifications for Adhesives for Duct Thermal Insulation". Adhesive used on the project shall meet the requirements of CALGreen section 5.504.4.1.
- E. Duct Liner Fasteners: Comply with SMACNA "HVAC Duct Construction Standards", Article S2.11.
- F. Duct Sealant: Non-hardening, non-migrating mastic or liquid elastic sealant, type applicable for fabrication/installation detail, as compounded and recommended by manufacturer specifically for sealing joints and seams in ductwork. Sealant used on the project shall meet the requirements of CALGreen section 5.504.4.1.
- G. Duct Cement. Non-hardening migrating mastic or liquid neoprene based cement, type applicable for fabrication/installation detail, as compounded and recommended by manufacturer specifically for cementing fitting components, or longitudinal seams in ductwork. Cement used on the project shall meet the requirements of CALGreen section 5.504.4.1.
- H. Ductwork Support Materials; Except as otherwise indicated, provide hot-dipped galvanized steel fasteners, anchors, rods, straps, trim and angles for support of ductwork. Provide seismic restraint as required.
- I. Flexible ducts: Acoustical flexible air duct for connection between air distribution ductwork and air inlets and outlets shall be factory fabricated assembly consisting of a porous inner sleeve of spun-bounded non-woven nylon, insulation and an outer moisture barrier, flameproof vinyl jacket, complying with UL 181; with factory installed metal collar connectors and maximum length 5 feet. Acoustical performance of the acoustical air duct shall be in accordance with Air Diffusion Council Flexible Air Duct Test FD72R1: Paragraph 3.2.1, sound attenuation. The test data shall be made by an accredited independent laboratory in accordance with the above testing procedure. The sound attenuation (Insertion loss) of the acoustical flexible air duct shall meet or exceed the values tabulated below:

Straight Duct Insertion Loss in Decibels per Foot of length

Octave Band Center Frequency, Hertz								
Acoustical Flexible Duct Inner Diameter	63	125	250	500	1000	2000	4000	8000
6"	-	3.0	4.0	3.6	3.8	3.8	3.4	3.0
8"	-	1.6	3.4	3.2	3.5	4.0	3.6	2.2
12"	-	2.0	2.6	2.8	3.4	3.6	2.6	2.0

- J. Provide Acoustical flexible ductwork of one of the following:
 1. JP Lamborn Co. AMF-07 (www.jplflex.com), Fresno, CA
 2. Casco, Silent-Flex II (www.casco-flex.com)
 3. Or approved equal
- K. Under slab Ducts: For ductwork placed in concrete slabs, or under slabs on grade, fabricate ductwork of one of the following materials:
 1. Galvanized Steel.

2.03 FABRICATION

- A. Shop-fabricate ductwork in 4, 8, 10 or 12-ft lengths, unless otherwise indicated or required to complete runs. Preassemble work in shop to greatest extent possible, so as to minimize field

assembly of systems. Disassemble systems only to extent necessary for shipping and handling. Match-mark sections for reassembly and coordinated installation.

- B. Shop-fabricate ductwork of gages and reinforcement complying with SMACNA "HVAC Duct Construction Standards".
- C. Fabricate duct fittings to match adjoining ducts, and to comply with duct requirements as applicable to fittings. Except as otherwise indicated, fabricate elbows with center-line radius equal to associated duct width; and fabricate to include turning vanes in elbows where shorter radius is necessary. Limit angular tapers to 30 degrees for contracting tapers and 20 degrees for expanding tapers.
- D. Fabricate ductwork with accessories installed during fabrication to the greatest extent possible. Refer to Division-23 section "Air Duct Accessories" for accessory requirements.
- E. Fabricate ductwork with duct liner in each section of duct where indicated. Laminate liner to internal surfaces of duct in accordance with instructions by manufacturers of lining and adhesive, and fasten with mechanical fasteners.

2.04 FACTORY-FABRICATED LOW PRESSURE DUCTWORK

- A. General: At Installer's option, provide factory-fabricated duct and fittings, in lieu of shop-fabricated duct and fittings.
- B. Material: Galvanized sheet steel complying with ASTM A517, lock forming quality, with ASTM A525, G90 zinc coating, mill phosphatized.
- C. Gage: 28-gage minimum for round and oval ducts and fittings, 4" through 24" diameter.
- D. Elbows: One-piece construction for 90 degrees and 45 degree elbows 14" and smaller. Provide multiple gore construction for larger diameters with standing seam circumferential joint.
- E. Divided Flow Fittings: 90-degree tees, constructed with saddle tap spot welded and bonded to duct fitting body.
- F. Manufacturers: Subject to compliance with requirements, provide factory-fabricated ductwork of one of the following or equal:
 1. Semco Mfg., Inc.
 2. United Sheet Metal Division, United McGill Corp.

PART 3 EXECUTION

3.01 INSPECTION

- A. General: Examine areas and conditions under which metal ductwork is to be installed. Do not proceed with work until unsatisfactory conditions have been corrected in a manner acceptable to Installer.

3.02 INSTALLATION OF METAL DUCTWORK

- A. General: Assemble and install ductwork in accordance with recognized industry practices which will achieve air-tight (5% leakage for systems rated 3" and under; 1% for systems rated over 3") and noiseless (no objectionable noise) systems capable of performing each indicated service. Install each run with minimum number of joints. Align ductwork accurately at connections, within 1/8" misalignment tolerance and with internal surfaces smooth. Support ducts rigidly with suitable ties, braces, hangers and anchors of type, which will hold ducts true-to-shape, and to prevent buckling. Support vertical ducts at every floor.
- B. Field Fabrication: Complete fabrication of work at project as necessary to match shop-fabricated work and accommodate installation requirements.

- C. Routing: Locate ductwork runs, except as otherwise indicated, vertically and horizontally and avoid diagonal runs wherever possible. Locate runs as indicated by diagrams, details and notations or, if not otherwise indicated, run ductwork in shortest route which does not obstruct useable space or block access for servicing building and its equipment. Hold ducts close to walls, overhead construction, columns, and other structural and permanent enclosure elements of building. Limit clearance to 1/2" where furring is shown for enclosure or concealment of ducts, but allow for insulation thickness, if any. Where possible, locate insulated ductwork for 1" clearance outside of insulation. Wherever possible in finished and occupied spaces, conceal ductwork from view, by locating in mechanical shafts, hollow wall construction or above suspended ceilings. Do not encase horizontal runs in solid partitions, except as specifically shown. Coordinate layout with suspended ceiling and lighting layouts and similar finished work.
- D. Electrical Equipment Spaces: Do not route ductwork through transformer vaults and their electrical equipment spaces and enclosures.
- E. Penetrations: Where ducts pass through interior partitions and exterior walls, and are exposed to view, conceal space between construction opening and duct or duct insulation with sheet metal flanges of same gage as duct. Overlap opening on 4 sides by at least 1-1/2". Fasten to duct and substrate.
 - 1. Where ducts pass through fire-rated floors, walls, or partitions, provide fire stopping between duct and substrate.
- F. Coordination: Coordinate duct installations with installation of accessories, dampers, coil frames, equipment, controls and other associated work of ductwork system.
- G. Installation: Install metal ductwork in accordance with SMACNA "HVAC Duct Construction Standards".

3.03 INSTALLATION OF DUCT LINERS

- A. General: Install duct liner in accordance with SMACNA "HVAC Duct Construction Standards".

3.04 INSTALLATION OF FLEXIBLE DUCTS

- A. Maximum Length: For any duct run using flexible ductwork, do not exceed 5'-0" extended length.
- B. Installation: Install in accordance with Section III of SMACNA, "HVAC Duct Construction Standards, Metal and Flexible" and shall be installed in accordance with the manufacturer's installation guide lines and recommended procedures. Before entering to the rear of any diffuser or grille, acoustical flex duct shall be straight and perpendicular to the diffuser for at least 3 duct diameters. Provide plenum box as shown on mechanical drawings for connection of flexible duct to the air inlet or outlets.
- C. Bends in flexible ducts shall have a radius of not less 1.5 times the internal diameters.

3.05 INSTALLATION OF KITCHEN EXHAUST DUCTS

- A. General: Fabricate joints and seams with continuous welds for watertight construction. Provide for thermal expansion of ductwork through 2000 degrees F (1093 degrees C) temperature range. Install without dips or traps, which may collect residues, except where traps have continuous or automatic residue removal. Provide access openings at each change in direction, located on sides of duct 1-1/2" minimum from bottom, and fitted with grease-tight covers of same material as duct.

3.06 EQUIPMENT CONNECTIONS

- A. General: Connect metal ductwork to equipment as indicated; provide flexible connection for each ductwork connection to equipment mounted on vibration isolators, and/or equipment containing rotating machinery. Provide access doors as indicated.

3.07 ADJUSTING AND CLEANING

- A. Clean ductwork internally, unit by unit as it is installed, of dust and debris. Clean external surfaces of foreign substances, which might cause corrosive deterioration of metal or, where ductwork is to be painted, might interfere with painting or cause paint deterioration.
- B. Temporary closure: At ends of ducts which are not connected to equipment or air distribution devices at time of ductwork installation, provide temporary closure of polyethylene film or other covering which will prevent entrance of dust and debris until time connections are to be completed.
- C. Balancing: Refer to Division-23 section "Testing, Adjusting and Balancing" for air distribution balancing of metal ductwork; not work of this section. Seal any leaks in ductwork that become apparent in balancing process.

END OF SECTION

SECTION 23 33 00
AIR DUCT ACCESSORIES

A. Types of ductwork accessories required for project include the following:

1. Damper
 - a. Low pressure manual dampers
 - b. Control dampers
 - c. Counter-balanced relief dampers
2. Fire and smoke dampers
3. Turning vanes
4. Duct hardware
5. Duct access doors
6. Flexible connections
7. Duct Silencer

1.02 RELATED SECTIONS

- A. Refer to other Division-23 sections for testing, adjusting, and balancing of ductwork accessories; not included in work of this section.
- B. Division 23 Section "Metal Ductwork".
- C. Division 25 Section "Automatic Temperature Control Systems".
- D. Division 23 Section "Mechanical Identification".

1.03 SUBMITTALS

- A. Product Data: Submit manufacturer's technical product data for each type of ductwork accessory, including dimensions, capacities, and materials of construction, performance; and installation instructions.

1.04 QUALITY ASSURANCE

- A. Codes and Standards:
 1. SMACNA Compliance: Comply with applicable portions of SMACNA "HVAC Duct Construction Standards, Metal and Flexible".
 2. Industry Standards: Comply with ASHRAE recommendations pertaining to construction of ductwork accessories, except as otherwise indicated.
 3. UL Compliance: Construct, test, and label fire dampers in accordance with UL Standard 555 "Fire Dampers and Ceiling Dampers".
 4. Fire dampers shall bear California State Fire Marshal Listing Number.
 5. NFPA Compliance: Comply with applicable provisions of NFPA 90A "Air Conditioning and Ventilating Systems", pertaining to installation of ductwork accessories.

PART 2 PRODUCTS

2.01 DAMPERS

- A. Low Pressure Manual Dampers: Provide dampers of single blade type or multi-blade type, constructed in accordance with SMACNA "HVAC Duct Construction Standards". "Jiffy" type dampers are not acceptable.

2.02 BACKDRAFT DAMPERS

- A. General: Provide back-draft dampers of types and sizes indicated. Construct casings of 0.090-inch thickness aluminum with mitered corners.
- B. Blades, 0.025" formed aluminum with extruded vinyl edge seals. Bearings, Zytel. Linkage 1/8" x 1/8" aluminum tie bars concealed in frame.

- C. Counter-balance: Zinc plated bar on blades (except top blade). Adjustable for final setting Mill finish.
- D. Manufacturers: Subject to compliance with requirements, provide dampers of one of the following:
 - 1. Ruskin Manufacturing Co.
 - 2. Air Balance Co.
 - 3. Pottorff Company, Inc.
- E. Control Dampers: Refer to Division-25 section "Control Systems" for control dampers; not work of this section.
- F. Counterbalanced Relief Dampers: Provide dampers with parallel blades, counterbalanced and factory-set to relieve at indicated static pressure. Construct blades of 16-ga. aluminum provide 1/2" diameter ball bearings, 1/2" diameter steel axles spaced on 9" centers. Construct frame of 2" x 1/2" x 1/8" steel channel for face areas 25 sq. ft. and under; 4" x 1-1/2" x 16-ga channel for face areas over 25 sq. ft. Provide galvanized steel finish on frame with aluminum touch-up.
- G. Manufacturer: Subject to compliance with requirements, provide dampers of one of the following:
 - 1. Air Balance, Inc.
 - 2. Ruskin Mfg. Co.
 - 3. Pottorff Company, Inc.

2.03 FIRE AND SMOKE DAMPERS

- A. California State Fire Marshal approved, designed and constructed in accordance with NFPA 90A and UL Standard 555 and bear stamp showing compliance.
- B. Fire Dampers: Provide fire dampers, of types and sizes indicated. Construct casings of 11-ga galvanized steel. Provide fusible link rated at 160 to 165 degrees F (71 to 74 degrees C) (unless otherwise indicated.) Provide damper with positive lock in closed position, and with the following additional features.
 - 1. Damper Blade Assembly: Curtain type.
- C. Manufacturer: Subject to compliance with requirements, provide fire and smoke dampers of one of the following:
 - 1. Air Balance, Inc.
 - 2. Ruskin Mfg. Co.
 - 3. Pottorff Company, Inc.

2.04 TURNING VANES

- A. Manufactured Turning Vanes: Provide turning vanes constructed of 1-1/2" wide curved blades set at 3/4" O.C., supported with bars perpendicular to blades set at 2" O.C., and set into side strips suitable for mounting in ductwork.
- B. Acoustic Turning Vanes: Provide acoustic turning vanes constructed of airfoil shaped aluminum extrusion with perforated faces and fiberglass fill.
- C. Manufacturer: Subject to compliance with requirements, provide turning vanes of one of the following:
 - 1. Aero Dynen Co.
 - 2. Anemostat Products Div.; Dynamics Corp. of America.
 - 3. Duro Dyne Corp.
 - 4. Environmental Elements Corp.; Subs, Koppers Co., Inc.
 - 5. Souther, Inc.

2.05 DUCT HARDWARE

- A. General: Provide duct hardware, manufactured by one manufacturer for all items on project, for the following:
 - 1. Test Holes: Provide in ductwork at fan inlet and outlet, and elsewhere as indicated, duct test holes, consisting of slot and cover, for instrument tests.
 - 2. Quadrant Locks: Provide for each damper, quadrant lock device on one end of shaft; and end bearing plate on other end for damper lengths over 12". Provide extended quadrant locks and end extended bearing plates for externally insulated ductwork.
- B. Manufacturer: Subject to compliance with requirements, provide duct hardware of one of the following:
 - 1. Ventfabrics, Inc.
 - 2. Young Regulator Co.

2.06 DUCT ACCESS DOORS:

- A. General: Provide duct access doors where required.
- B. Construction: Construct of same or greater gage as ductwork served, provide insulated doors for insulated ductwork. Provide flush frames for un-insulated ductwork, extended frames for externally insulated duct. Provide one side hinged other side with one handle-type latch for doors 12" high and smaller, 2 handle-type latches for larger doors.
- C. Manufacturer: Subject to compliance with requirements, provide duct access doors of one of the following:
 - 1. Air Balance Inc.
 - 2. Duro Dyne Corp.
 - 3. Register & Grille Mfg. Co., Inc.
 - 4. Ruskin Mfg. Co.
 - 5. Ventifabrics, Inc.
 - 6. Zurn Industries, Inc.; Air Systems Div.

2.07 FLEXIBLE CONNECTORS

- A. General: Provide flexible duct connections wherever ductwork connects to vibration-isolated equipment. Construct flexible connections of neoprene-coated flameproof fabric crimped into duct flanges for attachment to duct and equipment. Make airtight joint. Provide adequate joint flexibility to allow for thermal, axial, transverse and torsional movement, and also capable of absorbing vibration of connected equipment.
- B. Manufacturer: Subject to compliance with requirements, provide flexible connections of one of the following:
 - 1. American/Elgen Co.;Energy Div.
 - 2. Duro Dyne Corp.
 - 3. Flexaust (The) Co.
 - 4. Ventfabrics, Inc.

PART 3 EXECUTION

3.01 INSPECTION

- A. Examine areas and conditions under which ductwork accessories will be installed. Do not proceed with work until unsatisfactory conditions have been corrected in manner acceptable to Installer.

3.02 INSTALLATION OF DUCTWORK ACCESSORIES

- A. Install ductwork accessories in accordance with manufacturer's installation instructions, with applicable portions of details of construction as shown in SMACNA standards, and in accordance with recognized industry practices to ensure that products serve intended function.

- B. Install turning vanes in square or rectangular 90-degree elbows in supply and exhaust air systems, and elsewhere as indicated.
- C. Install access doors to open against system air pressure, with latches operable from either side, except outside only where duct is too small for person to enter.
- D. Coordinate with other work, including ductwork, as necessary to interface installation of ductwork accessories properly with other work.
- E. Install duct silencer strictly per manufacturer's recommendation based on project specific sound attenuation requirements and to meet all requirements by acoustical engineer of the record.

3.03 FIELD QUALITY CONTROL

- A. Operate install ductwork accessories to demonstrate compliance with requirements. Test for air leakage while system is operating. Repair or replace faulty accessories, as required to obtain proper operation and leak proof performance.

3.04 ADJUSTING AND CLEANING

- A. Adjusting: Adjust ductwork accessories for proper settings, install fusible links in fire dampers and adjust for proper action.
 - 1. Label access doors in accordance with Division-23 section "Mechanical Identification".
 - 2. Final positioning of manual dampers is specified in Division-23 section "Testing, Adjusting, and Balancing".
- B. Cleaning: Clean factory-finished surfaces. Repair any marred or scratched surfaces with manufacturer's touch-up paint.

3.05 EXTRA STOCK

- A. Furnish extra fusible links to Owner, through the process in Section 01 70 00, one link for every 10 installed of each temperature range; obtain receipt.

END OF SECTION

SECTION 23 34 23

HVAC POWER VENTILATORS

PART1 GENERAL

1.01 SECTION INCLUDES

- A. Types of power and gravity ventilators specified in this section include the following:
 - 1. Power ventilators.
 - a. Centrifugal roof ventilators.
 - b. In-Line roof ventilators.
 - 2. Gravity ventilators.
 - a. Hooded gravity ventilators.
 - 3. Prefabricated roof curbs.

1.02 RELATED SECTIONS

- A. Refer to Division-23 Section "Testing, Adjusting, and Balancing" for balancing of power and gravity ventilators; not work of this section.
- B. Refer to Division-23 Section "Common Motor Requirements for HVAC".
- C. Refer to Division 26 sections for the following work; not included in work of this section:
 - 1. Power supply wiring from power source to power connection on ventilators. Include starters, disconnects, and required electrical devices, except where specified as furnished, or factory-installed, by manufacturer.
- D. Refer to Division-23 Section "Vibration Control"

1.03 SUBMITTALS

- A. Product Data: Submit manufacturer's technical data for power and gravity ventilators, including specifications, capacity ratings, dimensions, weights, materials, accessories furnished, and installation instructions.
- B. Shop Drawings: Submit assembly-type shop drawings showing unit dimensions, construction details, methods of assembly of components, and field connection details.
- C. Wiring Diagrams: Submit manufacturer's electrical requirements for power supply wiring to power ventilators. Submit manufacturer's ladder-type wiring diagrams for interlock and control wiring. Clearly differentiate between portions of wiring that are factory-installed and portions to be field installed.
- D. Maintenance Data: Submit maintenance data and parts list for each type of power and gravity ventilator, accessory, and control. Include this data, product data, shop drawings, and wiring diagrams in maintenance manual; in accordance with requirements of Division 1.
- E. Exhaust fan unit equipment manufacturer shall furnish calculations showing the estimated sound power levels for each supply air, return air and unit casing radiation for each exhaust fan unit.
- F. The results of the tests shall be certified by the testing agency and submitted to the Architect for approval. The report shall include the manufacturer's designation of the tested unit, a complete description of the testing conditions, the measurement procedure, and the calculated PWL values (dB re. 10⁻¹² watts), and calculations showing how the sound power levels were obtained from test data.

1.04 QUALITY ASSURANCE:

A. Codes and Standards:

1. AMCA Compliance: Provide power ventilators, which have been tested and rated in accordance with AMCA standards, and bear AMCA Certified Rating Seal.
2. UL Compliance: Provide power ventilators, which are designed, manufactured, and tested in accordance with UL 705 "Power Ventilators".
3. NEMA Compliance: Provide motors and electrical accessories complying with NEMA Standards.

PART 2 PRODUCTS

2.01 POWER VENTILATORS

- A. General: Except as otherwise indicated, provide standard prefabricated power ventilator units of type and size indicated, modified as necessary to comply with requirements and as required for complete installation.

2.02 CENTRIFUGAL ROOF VENTILATORS (EXHAUST AND SUPPLY)

- A. Centrifugal Roof Ventilators: Provide centrifugal roof type, curb mounted, power ventilators of type, size, and capacity as scheduled, and as specified herein.
- B. Type: Centrifugal fan, direct or belt driven as scheduled. Provide aluminum, or fiberglass weatherproof housings as scheduled. Provide square base to suit roof curb.
- C. Motors: Provide permanent split-capacitor type motor for direct driven fans; capacitor-start, induction-run type motor for belt driven fans.
- D. Electrical: Provide factory-wired non-fusible type disconnect switch at motor in fan housing. Provide thermal overload protection in fan motor. Provide conduit chase within unit for electrical connection.
- E. Bird Screens: Provide removable bird screen, 1/2" mesh 16-ga aluminum or brass wire.
- F. Dampers: Provide gravity-actuated louvered dampers in curb bases unless noted to provide motorized louvered dampers with linkage in curb base.
- G. Manufacturer: Subject to compliance with requirements, provide centrifugal roof ventilators of one of the following:
1. Cook Co., Loren.
 2. Greenheck Fan Corp.
 3. Approved equal

2.03 GRAVITY VENTILATORS

- A. General: Except as otherwise indicated, provide standard prefabricated gravity ventilator units of type and size indicated, modified as necessary to comply with requirements, and as required for complete installation.
- B. Hooded Gravity Ventilators: Provide gravity ventilators, hooded type, curb mounted, of size, type and capacity as scheduled, and as specified herein.
1. Type: Stationary, natural draft type. Provide weatherproof housings to match power ventilators in materials and finish. Provide square or rectangular base to suit roof curb.
 2. Bird Screens: Provide removable bird screens, 1/2" mesh, 16-ga aluminum or brass wire.
 3. Dampers: Provide gravity-actuated louvered dampers in curb bases.
 4. Manufacturer: Subject to compliance with requirements, provide products of one of the following:
 - a. Cook Co., Loren.
 - b. Greenheck Fan Corp.
 - c. Approved equal

2.04 PREFABRICATED ROOF CURBS

- A. General: Provide manufacturer's standard shop-fabricated units, modified if necessary to comply with requirements.
- B. Fabricate structural framing for units of structural quality, aluminum formed to profiles indicated or, if not indicated, to manufacturer's standard profiles for coordination with roofing, insulation and deck construction. Include 45-degree cant strips and deck flanges with offsets to accommodate roof insulation. Weld corners and seams to form watertight units.
- C. Reinforce continuous runs of over 3'-0" length by inserting welded stiffeners of heavy gage with flanges as required to provide sufficient rigidity and strength to withstand maximum lateral forces in addition to superimposed vertical loads.
- D. Sloping Roof Decks: For deck slopes of 1/4" per foot and more, fabricate support units to form level top edge.
- E. Gage and Height: Fabricate units of metal gage and to height above roof surface as indicated.
 - 1. Where gage or height is not indicated, fabricate units of 14-ga metal, and nominal height of 14".
- F. Insulate units inside structural support wall with rigid glass fiber insulation board of approximately 3-lb. density and 1-1/2" minimum thickness, except as otherwise indicated.
- G. Provide support liners where shown.
 - 1. Use perforated metal for support liners, with approximately 1000, 3/32" diameter holes per sq. ft., to provide sound absorbing surfaces.
 - 2. Provide sound insulation insert for curbs so indicated. Construct of 1" thick rigid fiberglass panels secured in galvanized steel framework, with rounded edges to minimize airflow resistance.
- H. Manufacturer: Subject to compliance with requirements, provide prefabricated roof curbs of the same manufacturer as ventilator.

PART 3 EXECUTION

3.01 INSPECTION

- A. General: Examine areas and conditions under which power and gravity ventilators are to be installed. Do not proceed with work until unsatisfactory conditions have been corrected.

3.02 INSTALLATION OF POWER AND GRAVITY VENTILATORS

- A. General: Except as otherwise indicated or specified, install power ventilators in accordance with manufacturer's installation instructions and recognized industry practices to insure that products serve the intended function.
- B. Coordinate ventilator work with work of roofing, walls and ceilings, as necessary for proper interfacing.
- C. Ductwork: Refer to Division-23 Section "Metal Ductwork." Connect ducts to ventilators in accordance with manufacturer's installation instructions.
- D. Roof Curbs: Furnish roof curbs to roofing Installer for installation.
- E. Electrical Wiring: Install electrical devices furnished by manufacturer but not specified to be factory-mounted. Furnish copy of manufacturer's wiring diagram submittal to Electrical Installer.
 - 1. Verify that electrical wiring installation is in accordance with manufacturer's submittal and installation requirements of Division-26 Sections. Verify proper rotation direction of fan wheels. Do not proceed with equipment start-up until wiring installation is acceptable to equipment installer.

- F. Remove shipping bolts and temporary supports within ventilators. Adjust dampers for free operation.

3.03 FIELD QUALITY CONTROL

- A. Testing: After installation of ventilators has been completed, test each ventilator to demonstrate proper operation of unit at performance requirements specified. When possible, field correct malfunctioning units, and then retest to demonstrate compliance. Replace units, which cannot be satisfactorily corrected.

3.04 ADJUSTING AND CLEANING

- A. Cleaning: Clean factory-finished surfaces. Repair any marred or scratched surfaces with manufacturer's touch-up paint.

3.05 SPARE PARTS

- A. General: Furnish to Owner, with receipt, one spare set of belts for each belt driven power ventilator.

END OF SECTION

SECTION 23 37 00

AIR OUTLETS AND INLETS

PART 1 GENERAL

1.01 SECTION INCLUDES

- A. Types of outlets and inlets required for project include the following:
 - 1. Linear slot diffusers and returns.
 - 2. Ceiling air diffusers, rectangular, square, round.
 - 3. Wall registers and grilles.

1.02 RELATED SECTIONS

- A. Refer to other Division-23 sections for ductwork and duct accessories required in conjunction with air outlets and inlets; not work of this section.
- B. Refer to other Division-23 sections for balancing of air outlets and inlets; not work of this section.

1.03 SUBMITTALS

- A. Product Data: Submit manufacturer's technical product data for air outlets and inlets including the following:
 - 1. Schedule of air outlets and inlets indicating drawing designation, room location, number furnished, model number, size, and accessories furnished.
 - 2. Data sheet for each type of air outlet and inlet, and accessories furnished; indicating construction, finish, and mounting details.
 - 3. Performance data for each type of air outlet and inlet furnished, including aspiration ability, temperature and velocity traverses; throw and drop; and noise criteria ratings. Indicate selections on data.
 - 4. ANSI/ASHRAE Standard 70-1991.
- B. Shop Drawings: Submit manufacturer's assembly-type shop drawing for each type of air outlet and inlet, indicating materials and methods of assembly of components.
- C. Maintenance Data: Submit maintenance data, including cleaning instructions for finishes, and spare parts lists. Include this data, product data, and shop drawings in maintenance manuals; in accordance with requirements of Division 01.

1.04 PRODUCT DELIVERY, STORAGE AND HANDLING

- A. Deliver air outlets and inlets wrapped in factory-fabricated fiberboard type containers. Identify on outside of container type of outlet or inlet and location to be installed. Avoid crushing or bending and prevent dirt and debris from entering and settling in devices.
- B. Store air outlets and inlets in original cartons and protect from weather and construction work traffic. Where possible, store indoors, when necessary to store outdoors, store above grade and enclose with waterproof wrapping.

1.05 QUALITY ASSURANCE

- A. Codes and Standards:
 - 1. ANSI/ASHRAE Compliance: Test and rate air outlets and inlets in certified laboratories under requirements of ANSI/ASHRAE Standard 70-1991.
 - 2. NFPA Compliance: Install air outlets and inlets in accordance with NFPA 90A "Standard for the Installation of Air Conditioning and Ventilating Systems".

PART 2 PRODUCTS

2.01 CEILING AIR DIFFUSERS

- A. General: Except as otherwise indicated, provide manufacturer's standard ceiling air diffusers where shown; of size, shape, capacity and type indicated; constructed of materials and components as indicated, and as required for complete installation.
- B. Performance: Provide ceiling air diffusers that have, as minimum, temperature and velocity traverses, throw and drop, and noise criteria ratings for each size device as listed in manufacturer's current data.
- C. Ceiling Compatibility: Provide diffusers with border styles that are compatible with adjacent ceiling systems, and that are specifically manufactured to fit into ceiling module with accurate fit and adequate support. Refer to general construction drawings and specifications for types of ceiling systems, which will contain each type of ceiling air diffuser.

2.02 MANUFACTURER

- A. Subject to compliance with requirement diffusers of one of the following:
 - 1. Price Industries.
 - 2. Kreuger Mfg. Co.
 - 3. Nailor Industries, Inc.
 - 4. Titus Air Distribution Products
 - 5. Anemostat Air Distribution Products
- B. Manufacturers and model numbers are listed and/or scheduled to set a standard of quality. Equivalent manufacturers and models accepted by Architect/Engineer may be used. Equivalents must be for review.
 - 1. Equivalents: Other manufacturers offering a similar product which is in accordance with the design criteria indicated may be submitted upon architect's written acceptance prior to bidding. The cost to conduct all tests as may be directed by the architect to demonstrate that the equivalent product can achieve the criteria indicated, including all travel costs, shall be borne by the submitting contractor.

2.03 LINEAR SLOT DIFFUSER AND RETURN

- A. General: Provide acoustical ceiling air distribution system. Consisting of ceiling slot air diffusers, base frames, air chambers and entry collars.
- B. Air Distribution Base Frames:
 - 1. Linear air diffusers base frames shall mechanically lock into the grid system. The base frames shall be extruded aluminum sections. Length shall be 48" unless otherwise noted or required.
 - 2. Provide air distribution base frame with full supply air pattern control air weir gates. When used for return air, these air weir gates act as a return airflow control damper. Close air weir gates where return is not necessary.
 - 3. Base frame shall present a substantially uniform appearance through the air slot when used as supply, returns or fully closed. All interior portions of the throat, including the vertical stems of the extrusions, shall be painted flat black to prevent unsightly visual deviations. Paint all exposed surfaces baked white enamel. Base frame shall be compatible with type of ceiling where linear slot diffuser is installed.
 - 4. Base frame shall be provided with spacer channels located on the ceiling module. The spacer channel shall act as the support means for the adjustable full pattern control air weir gates, which are provided throughout the entire length of the base frame.
 - 5. The noise criteria of the air distribution base frame shall be expressed in sound power levels (decibels 10-12 watts) in octave bands 2 through 7 with a room attenuation of 10 decibels and shall not exceed a noise criteria of 30. All data shall be based on tests performed in a certified laboratory.
 - 6. Where noted on drawings or as required, blank-off airtight backside of supply air linear slot where duct connection is not made.

C. Supply or Return Air Chambers:

1. Supply or Return air plenum chambers shall be designed, tested, and fabricated by the same manufacturer that furnishes the base frames. Shop fabricated air chambers not acceptable. Provide with damper at inlet to plenum, which is accessible through face of linear diffuser for adjustment.
2. Provide adjustable air pattern controllers that are accessible through the base frame slot for field adjustment of the spread of the air stream. This will be accomplished without the removal of acoustical tile.
3. Provide a round neck air entry collar sized for maximum average air entry velocity of 750 FPM. A volume damper shall be installed at connection to plenum, which is accessible through face of diffuser for adjustment.
4. Construct supply air chamber from not less than 26 gauge galvanized steel and will be lined with one-quarter inch 2 lb./cu. ft. density thermal acoustical insulating. All surfaces visible through the slot will be painted flat black.
5. Provide spring clip keepers to securely attach the chamber to the base frame when in operation. These spring clips permit releasing of the air chamber for easy relocation.
6. The supply air chamber shall have been tested as composite assembly with the linear base frame for air distribution and noise level performance. The tests shall be conducted in accordance with ANSI/ASHRAE Standard 70-1991.
7. For return air plenums above the ceiling, install Krueger model DFRH plenum hood on all linear return air bars.

D. Manufacturer: Krueger model DFL linear slot diffuser or approved equal.

2.04 CEILING RETURN AND EXHAUST GRILLES AND REGISTERS

(All constant air volume systems unless otherwise noted.)

- A. Concealed Spline - Krueger ASDT
- B. Glued on Acoustile - Krueger ASDT
- C. Plaster or drywall- Krueger EGC5 or EGC5-01.
- D. 24" x 24" T-bar- Krueger EGC5 or EGC5-01.

Note: For 24" x 48" T-bar ceilings, coordinate with ceiling installer for auxiliary tees as required to provide 24" x 24" space.

2.05 SIDEWALL SUPPLY AND RETURN REGISTERS AND GRILLES

- A. Supply register- Krueger aaov.
- B. Return register- Krueger sao.
- C. Return grille - Krueger sao.

2.06 TRANSFER GRILLES

- A. Ceiling - Same as return grilles.

2.07 CEILING DIFFUSERS (SUPPLY)

(Constant air volume systems unless otherwise noted.)

- A. Concealed Spline - Krueger ASDT
- B. Glued on Acoustile - Krueger ASDT
- C. Plaster or Drywall- Krueger 1240
- D. 24" x 24" T-Bar- Krueger 1240

Note: For 24" x 48" T-bar ceilings, coordinate with ceiling installer for auxiliary tees as required to create 24" x 24" space.

2.08 MODULAR CEILING DIFFUSERS

(All V.A.V. systems unless otherwise noted.)

- A. Krueger Model 1900SQ and shall have a frame style to interface with the ceiling grid system being used.
- B. Manufactured from extruded aluminum. Provided with air pattern control weirs, and an integral deflection rail allowing for one- to four-way direction air flow producing uniform ceiling effect.
- C. The air motion in the occupancy zone at maximum cubic feet per minute shall not exceed 50 feet per minute. Inner panel of matching acoustical tile shall provide an airtight joint.
- D. Supply, Return and Exhaust Chambers:
 - 1. Designed and fabricated by the manufacturer of the base frames. Field fabricated chambers will not be accepted. Chamber to be supplied with spring clips to attach to the base frame. Constructed from not less than 26 gauge galvanized steel and lined with 1/4" 2 LB./CU. FT. density thermal insulation. All surfaces visible through the air slot painted flat black.
 - 2. Chamber shall be supplied with a factory installed round entry collar for flex duct connection. Collar shall be sized for maximum average air entry velocity of 750 fpm. Chamber must be tested as a composite assembly with the base frame for air distribution and noise level performance by a certified testing laboratory. If used with side inlet, furnish and install vertical pressure equalizing baffle.

2.09 MODULAR CEILING RETURN

(All V.A.V. systems unless otherwise noted.)

- A. Krueger Model 1900SQ return diffuser.
- B. Base frame from extruded aluminum. Frame shall have fixed weirs creating a continuous one-inch closed slot. Provide opposite blade volume damper.
- C. The slots connection to each other is provided with tabs at each corner of slots. These tabs shall be solid and no holes shall be on these tabs, to reduce the visibility of these tabs paint with dark color (Black).

2.10 SUPPLY, RETURN AND EXHAUST CONNECTIONS TO METAL LINEAR CEILING

- A. Air Factors sheet metal air boot (eight-slot) for connecting to back of metal linear ceiling with slot openings (with labyrinths, as applicable) for supply, return, and exhaust. Air boot shall lock onto back of ceiling system.

2.11 CIRCULAR CEILING DIFFUSERS

(All circular ceiling diffusers unless otherwise noted.)

- A. Krueger Model RA2 circular diffuser with adjustable inner cone.

PART 3 EXECUTION

3.01 INSPECTION

- A. Examine areas and conditions under which air outlets and inlets are to be installed. Do not proceed with work until unsatisfactory conditions have been corrected.

3.02 INSTALLATION

- A. General: Install air outlets and inlets in accordance with manufacturer's written instructions and in accordance with recognized industry practices to insure that products serve intended function.
 - B. Coordinate with other work, including ductwork and duct accessories, as necessary to interface installation of air outlets and inlets with other work.
 - C. Coordinate ceiling air diffusers, registers, and grilles, as indicated on general construction "Reflected Ceiling Plans". Unless otherwise indicated, locate units in center of acoustical ceiling module.
 - D. Supply outlets to provide the required air throw and spread with no apparent drafts or excessive air movement within space being supplied. Contractor to provide necessary accessories to accomplish satisfactory air distribution.
 - E. Provide felt, cork or rubber gasket between finish surface and frame to prevent vibration and assure tight fit. Contractor shall be responsible for the correct location of ductwork and outlets.
 - F. For filler panel type outlets the manufacturer shall coordinate his design with the ceiling suspension system being used. The Contractor and manufacturer shall match up sizes of outlets to properly fit in ceiling systems, between concrete or masonry components, between architectural items before fabrication.
 - G. When installing removable core type outlets, secure to frame with screws.
- G. Secure outlets to ceiling suspension systems as required by Division of the State Architect.

END OF SECTION

NOTE: ENSURE THAT HVAC TECHS REVIEW IN TERMS OF EQUIPMENT MANUFACTURER AND COMPONENTS

SECTION 23 81 19

PACKAGED ROOFTOP AIR CONDITIONER

PART 1 GENERAL

1.01 SECTION INCLUDES

- A. Section includes package rooftop heating and cooling units.

1.02 RELATED SECTIONS

- A. Division 23
 - 1. Section "Common Motor Requirement for HVAC."
 - 2. Section "Natural Gas Systems"
 - 3. Section "Ductwork"
 - 4. Section "Air Cleaning"
 - 5. Section "Testing, Adjusting, and Balancing"
- B. Division 26
 - 1. Section "Electrical Connections for Equipment"

1.03 SUBMITTALS

- A. Product Data: Submit manufacturer's technical product data, including rated capacities at scheduled conditions of selected model clearly indicated, dimensions, required clearances, weights, furnished specialties and accessories; and installation and start-up instructions.
- B. Shop Drawings:
 - 1. Submit shop drawings detailing the manufacturer's electrical requirements for power supply wiring for rooftop heating and cooling units. Clearly differentiate between portions of wiring that are factory-installed and portions to be field-installed.
 - 2. Submit shop drawings detailing the mounting, securing, and flashing of the roof curb to the roof structure.
 - 3. Submit shop drawings detailing method of securing rooftop unit to roof curb to meet seismic restraint requirement.
 - 4. If an equal unit is being proposed to be used in lieu of the base specified unit, the contractor shall coordinate all differences as hereinafter described and note such differences on the shop drawings and incorporate all changes (if any) required by the structural and electrical engineers to accommodate the equal unit.
- C. Operation and Maintenance Data: Submit maintenance data and parts list for each rooftop unit, including "trouble-shooting" maintenance guide, servicing guide and preventative maintenance schedule and procedures. Include this data in maintenance manual in accordance with requirements of Division 01.

1.04 QUALITY ASSURANCE

A. Codes and Standards:

1. Gas-Fired furnace section construction shall be in accordance with AGA safety standards. Furnace section shall bear the AGA label.
2. Testing and rating of rooftop units of 135, 000 Btu/hr capacity or over shall be in accordance with ARI 360 "Standard for Commercial and Industrial Unitary Air-Conditioning Equipment".
3. Testing and rating of rooftop units under 135,000 Btu/hr capacities shall be in accordance with ARI 210 "Standard for Unitary Air-Conditioning Equipment", and provide Certified Rating Seal. Sound testing and rating of units shall be in accordance with ARI 270 "Standard for Sound Rating of Outdoor Unitary Equipment". Units shall bear Certified Rating Seal.
3. Refrigerating system construction of rooftop units shall be in accordance with ASHRAE 15

3.3. "Safety Code for Mechanical Refrigeration".

3.4. 5. Energy Efficiency Ratio (EER) or (SEER) of rooftop units shall be equal to or greater than prescribed by Title 24- California Code of Regulations" (CCR) and as scheduled.

3.5. 6. Rooftop units shall be designed, manufactured, and tested in accordance with UL

3.6. requirements.

3.7. 7. Rooftop units shall comply with SCAQMD Low NOx requirements

3.8.

3.9.

3.10.

1.05 DELIVERY, STORAGE, AND HANDLING

3.11. A. Handle rooftop units and components carefully to prevent damage. Replace damaged rooftop units or components with new.

3.12.

3.13.

B. Store rooftop units and components in clean dry place, off the ground and protect from weather, water, and physical damage.

3.14.

3.15.

C. Rig rooftop units to comply with manufacturer's rigging and installation instructions for unloading rooftop units, and moving them to final location.

3.16.

3.17.

3.18.

1.06 SCHEDULING AND SEQUENCING

3.19.

3.20.

A. Coordinate installation of roof mounting curb with roof structure.

3.21.

3.22.

B. Coordinate roof-opening locations for mechanical and electrical connections.

3.23.

3.24.

1.07 SPECIAL WARRANTY

3.25.

A. Warranty on Compressor (and Heat Exchanger): Provide written warranty, signed by manufacturer, agreeing to replace/repair, within warranty period, compressors (and heat exchangers) with inadequate and defective materials and workmanship, including leakage, breakage, improper assembly, or failure to perform as required; provided manufacturer's instructions for handling, installing, protecting, and maintaining units have been adhered to during warranty period. Replacement is limited to component replacement only, and does not include labor for removal and reinstallation.

3.26.

3.27.

1. Warranty Period: 4 years extension from date of basic 1-year warranty-See Division 1.

3.28.

3.29.

1.08 MAINTENANCE

3.30.

A. Extra Materials: Furnish to Owner, through the process in Section 01 70 00, with receipt, the following spare parts for each rooftop heating and cooling unit:

3.31.

1. One set of matched fan belts for each belt-driven fan.

PART 2 PRODUCTS

3.32.

3.33.

2.01 ROOFTOP UNITS (GENERAL)

- 3.34. A. General Description: Units shall be factory-assembled and tested, designed for roof or slab installation, and consisting of compressors, condensers, evaporator coils, heat exchanger, condenser and evaporator fans, refrigeration and temperature controls, filters, and dampers.
- 3.35.
- 3.36. B. Units as manufactured by Carrier Corporation were used as the basis of design and their efficiencies are the bases of T-24 energy compliance calculation and DSA High Performance Incentive (HPI) Grant. Their capacities, weights and electrical characteristics are scheduled on the drawings. Units shall be designed for refrigerant R-410a.
- 3.37.
- ~~3.38.~~ 2.02 ROOFTOP AIR CONDITIONING UNIT
- ~~3.39.~~
- 3.40. A. Unit shall be of the single-package type, combination air-to-air cooling and gas-fired heating.
- ~~3.41.~~ Unit shall be AGA certified and meet requirements of CCR Title 24 and ASHRAE/IESNA 90.1.
- ~~3.42.~~
- 3.43. B. Unit shall be EER or SEER rated in accordance with ARI Standard 210-81 and California
- 3.44. Administrative Title 24.
- C. Compressor(s)- The unit shall contain (one or two) as scheduled, welded, fully hermetic scroll compressor(s) with suitable vibration isolators, overload protection, and crankcase heater and shall have a 5-year warranty.
- D. Coils shall be constructed of aluminum fins mechanically bonded to copper tubes. Provide an independent expansion device for each refrigeration circuit. Factory pressure tested at 450 psig and leak tested at 200 psig. Evaporator coils shall be equipped with capillary restrictor. Condenser coils facing the exterior of the unit shall be equipped with screen protection grille.
- E. Filter enclosure – The unit shall contain filter enclosure that positively prevent air by-pass of the filters. (HPI EQ2.1)
- F. Filter media shall provide at least a minimum efficiency reporting value (MERV) of 13. (HPI EQ2.1)
- G. Filter gage – differential pressure gage equal to dwyer series 2000 with adjustable signal flag and air filter kit. Pressure gage shall be markable with manufacturer marking accessories. Select pressure range of gage per manufacturer's recommendation. Field installation of pressure gage shall be coordinated with unit manufacturer. Penetration through unit wall shall be made weather resistance. (HPI EQ2.1)
- H. Fans and motors- The evaporator air fan shall be of the forward-curved centrifugal type, direct-drive multi-speed or adjustable belt-driven as shown on the equipment schedule. Condenser fan motor shall have ball bearings. Sleeve type bearings are not acceptable. Condenser air fan shall be of the propeller type, directly driven and discharging upward.
- I. Heat exchanger shall be tubular in design and constructed of 409 stainless steel heat exchanger corrosion-resistant aluminized steel. Heat exchanger shall carry a 15-year non-prorated warranty.
- J. Refrigerant: R-410A.
- K. Safety controls- Cooling section shall be protected by low pressurestat, high pressure switch, compressor motor overloads, crankcase heaters, freezestat and .lockout circuit that prevents compressor short cycling as a result of a rapid change in thermostat setting by automatically preventing compressor restart for at least 5 minutes.
- L. Heating controls shall consist of a redundant gas valve, intermittent pilot ignition system, limit switches, centrifugal switch, and rollout switch. Heating section shall be designed for induced-draft combustion. Forced-draft is not acceptable.
- M. Roof Curb.
1. General: Roof Curb shall be of down-shot arrangement and shall be of an approved manufacturer as indicated on the drawings and specification section 23 05 48 and shall include an insulated panel under compressor section to prevent condensation forming on

the bottom. Dimensions shall be provided to allow for each duct location and connection to roof curb prior to unit placement. Roof curb shall be a minimum of 16 in. high, except otherwise noted on drawings. Curb design shall comply with National Roofing Contractors Association requirements.

2. Isolation Roof Curb Type: Roof Curbs shall be of Prefabricated Isolation Curb type. Unit manufacturer shall furnish spring isolation curbs specifically deigned for the air conditioning units. Isolation curb isolators must be pre-approved OSHPD. Pre-approval number must be included with the submittal. OSHPD approval Numbers must be included with the submittal. Numbers subject to approval will not constitute pre-approval. Springs must be a minimum of 2" deflection with seismic restraint. Curb shall have access doors for easy inspection and adjustment of each spring without dismantling any portion of the unit or curb assembly. Isolation curb must include a vandal-proof, galvanized steel counterflashing skirt to assure long-term air and water seal integrity. Exposed rubber skirt seals are not acceptable. Curb and flashing shall be fully welded. Field assembled and bolted construction not acceptable. Seismic attached (hold-down) clips with certified calculations by a registered California structural engineer shall be furnished with the isolation curb. Installation prior to submittal approval by mechanical engineer shall be subject to removal without any cost or obligation to the Owner. The contractor shall not install any unit without written approval.
- N. Power Exhaust and Economizer: Power exhaust shall have a modulating centrifugal blower provided with variable frequency drive (VFD). Economizer control (Down-shot) shall include return air (R.A.) and outdoor air filter and hood, and fully modulating electric control system with O.A. thermostat and mixed air thermostat. Economizer control shall be capable of introducing up to 100% outdoor air. Power Exhaust shall be capable of relieving 100% of system air. The control changeover from mechanical cooling to economizer operation shall be fully automatic through an adjustable integrated control sensing pre-assigned outside air requirements. Economizer shall be integrated type capable of simultaneous compressor and economizer operation for maximum benefit of outdoor air. Economizer shall utilize low-leakage, opposing blade, gear driven dampers with UL approved gears. Provide economizer control for all units unless specifically indicated otherwise. Economizer shall incorporate a full sized barometric relief that has the same face area as the outside air inlet. The relief shall be sized to relieve up to 100% relief air.
- O. Air Intake- Air intakes shall be designed to limit water penetration through the intake to 0.07 oz/sqft-Hr of inlet area per section 58 of UL 1995. (HPI EQ2.0A)
- P. Rain Intrusion-Unit shall be designed to prevent rain intrusion into airstream when test at design airflow and with no airflow per section 58 of UL 1995. (HPI EQ2.0A)
- Q. Bird Screen-Provide bird screen capable to prevent penetration by a 0.5 inch diameter probe. The bird screen shall be corrosion resistant. The screening device shall be located to prevent bird nesting on horizontal surface at the outdoor air intake. (HPI EQ2.0A)
- R. Thermostat assembly shall provide staged heating and cooling, manual and automatic changeover, fan control and integrated time delay protection.
- S. Unit Casing
1. Cabinet: Galvanized steel, phosphatized, and finished with an air-dry paint coating with removable access panels. Structural members shall be 18 gauge with access doors and removable panels of minimum 20 gauge.
 2. Cabinet Interior: Finish of interior surface in contact with the airstream shall comply with requirements of ASHRAE 62.1-2007.
 3. Unit cabinet's exterior surface shall be tested for 1000 hours salt spray test in compliance with ASTM B117.
 4. Cabinet construction shall allow for all service/ maintenance from one side of the unit.
 5. Cabinet top cover shall be one piece construction, or where a seam exists, it shall be double-hemmed and gasket-sealed.

6. Access Panels: Water- and air-tight panels with handles shall provide access to filters, heating section, return air fan section, supply air fan section, evaporator coil section, and unit control section.
7. Unit Base Pan: Units base pan shall comply with ASHRAE 62.1-2007 requirements for drain pan construction and connections and shall have a raised 1-1/8 inch high lip around the supply and return openings for water integrity.
8. Insulation: Provide 1/2 inch thick fiberglass insulation with foil face on all exterior panels in contact with the return and conditioned air stream. All edges must be captured so that there is no insulation exposed in the air stream.
9. Provide 115-volt convenience outlet, factory-installed and unpowered, per NEC requirements.
10. Provide openings either on side of unit or through the base for power, control, condensate, and gas connections as shown on contract document drawings.
11. The base of the unit shall have 3 sides for forklift provisions. The base of the units shall have rigging/lifting holes for crane maneuvering.

2.03 MANUFACTURERS

- A. Subject to compliance with the requirements project documents provide packaged rooftop air conditioning unit of one of the following manufacturer:
 1. Carrier Corporation, Basis of Design
 2. York
 3. Or Equal, Sections 01 33 13, 01 40 00, 01 60 00
- B. Carrier Corporation units are used as the basis of design and their efficiencies are the bases of energy calculations for Title-24 compliance. Contractor submitting units by other manufacturers named in this specification as alternate shall provide the required Title-24 calculations demonstrating compliance. This effort shall be at no cost to the owner, and all required calculations shall be submitted within 14 calendar days after the award of contract. Job will be awarded on basis of specified product. Alternates must comply with the performance and features as specified within these specifications and indicated on the design documents. Any and all additional cost due to submission of alternate units for redesign and/or increase in construction cost of other trades and/or re-submittal fee to authorities shall be bonded by the contractor.

2.04 CONTROLS

- A. Control Module: Unit-mounted digital panel for interlock with the energy management system for heating, cooling, and fan operation. Include the following features (Refer to drawings for additional requirements):
 1. Low Ambient Lockout Control: Prevents cooling-cycle operation below 40 deg F outdoor air temperature.
 2. Temperature-Limit Control: Prevents occupant from exceeding preset setup temperature.
 3. Building Automation System Interface: Allows remote on-off control with setback temperature control.
- B. Remote Control: Standard unit-mounted controls with remote-mounted, low-voltage adjustable thermostat with heat anticipator, heat-off-cool-auto switch, and on-auto fan switch. (Refer to drawings for additional requirements).

2.05 CAPACITIES AND CHARACTERISTICS

- A. Outdoor Air-Intake Rate: Unit outdoor air-intake rates shall be per equipment schedules on contract document drawings.
- B. Cooling Capacity: Unit cooling capacities shall be per equipment schedules on contract document drawings.
- C. Energy-Efficiency Ratio: Minimum unit Energy-Efficiency (EER) or Seasonal Energy Efficiency (SEER) Ratios shall be per equipment schedule on contract document drawings.

- D. AFUE: Minimum unit AFUE shall be per equipment schedules on contract document drawings.

PART 3 EXECUTION

3.01 EXAMINATION

- A. Examine areas and conditions under which rooftop units are to be installed. Do not proceed with work until unsatisfactory conditions have been corrected in a manner acceptable to Installer.

3.02 INSTALLATION

- A. General: Install rooftop units in accordance with manufacturer's installation instructions. Install units plumb and level, firmly anchored in locations indicated, and maintain manufacturer's recommended clearances.
- B. Support: Install and secure roof curb to roof structure, in accordance with National Roofing Contractor's Association (NRCA) installation recommendations and shop drawings. Install and secure rooftop units on curbs and coordinate roof penetrations and flashing.
 - 1. Provide substructure as required to set curbs plumb and level.
- C. Electrical Connections: Refer to Section "Electrical Connections for Equipment" for final connections to equipment and installation of loose shipped electrical components.
- D. Unit protection: At ends of ducts which are not connected to equipment or air distribution devices at time of ductwork installation, or the period of rough installation, or during storage on the construction site and until final startup of the heating and cooling equipment, provide temporary closure of duct openings and protection of mechanical equipment during construction. All duct and other related air distribution component openings shall be covered with polyethylene film, tape, plastic, sheet metal or other methods acceptable to the enforcing agency which will prevent entrance of dust and debris.

3.03 DEMONSTRATION

- A. Start-Up Services:
 - 1. Provide the services of a factory-authorized service representative to start-up rooftop units, in accordance with manufacturer's written start-up instructions. Test controls and demonstrate compliance with requirements. Replace damaged or malfunctioning controls and equipment. Provide written start-up report for each unit.
- B. Operating and Maintenance Training:
 - 1. Provide services of manufacturer's service representative to instruct Owner's personnel in operation and maintenance of rooftop units. Training shall include start-up and shutdown, servicing and preventative maintenance schedule and procedures, and trouble shooting procedures plus procedures for obtaining repair parts and technical assistance. Review operating and maintenance data contained in the Operating and Maintenance Manuals specified in Division One.
 - 2. Schedule at Owner's convenience, one 2-hour operations and maintenance session, during normal working hours, 6:30 a.m. to 3:00 p.m., Monday through Friday. In addition, schedule one follow-up 1-hour operations and maintenance session within the first three months of system operation at Owner's convenience, during normal working hours (as outlined above).

END OF SECTION

SPLIT AIR CONDITIONING SYSTEM

PART1 GENERAL

1.01 SECTION INCLUDES

- A. Split DX cooling only and heat pump system with indoor split DX fan coil and outdoor cooling/condensing unit.

1.02 RELATED SECTIONS

- A. Related sections include but are not limited to the following:
 - 1. Division 23
 - a. Section Common Work Results for HVAC
 - b. Section Common Motor Requirements for HVAC
 - c. Section Temperature Control Systems required in conjunction with split cooling system
 - d. Section Testing, Adjusting and Balancing
 - e. Section "Maximum Sound Power Level for Fan Equipment"
 - 2. Division - 26:
 - a. Section Electrical Connections for Equipment

1.03 SUBMITTALS

- A. Product Data: Submit manufacturer's technical product data, including rated capacities of selected model clearly indicated, dimensions, required clearances, weights, furnished specialties and accessories; and installation and start-up instructions.
- B. Shop Drawings: Submit shop drawings detailing the manufacturer's electrical requirements for power supply wiring for rooftop cooling/condensing and DX fan coil units.

Submit manufacturer's ladder-type wiring diagrams for interlock and control wiring. Clearly differentiate between portions of wiring that are factory-installed and portions to be field-installed.

- 2. Submit shop drawings detailing the mounting, securing, and flashing of the outdoor unit to redwood sleepers and sleepers to the roof structure. Indicate coordinating requirements with roof membrane system.
- C. Operation and Maintenance Data: Submit maintenance data and parts list for each split cooling system, including "trouble-shooting" maintenance guide, servicing guide and preventative maintenance schedule and procedures. Include this data in maintenance manual in accordance with requirements of Division 01.

1.04 QUALITY ASSURANCE

- A. Codes and Standards:
 - 1. Refrigerating system construction of split cooling system shall be in accordance with ASHRAE 15 "Safety Code for Mechanical Refrigeration".
 - 2. Seasonal Energy Efficiency Ratio (SEER) of split cooling system shall be equal to or greater than prescribed by Title 24 California Administrative Code "2005 Building Energy Efficiency Standards".
 - 3. Split cooling system shall be designed, manufactured, and tested in accordance with UL requirements.

1.05 DELIVERY, STORAGE AND HANDLING

- A. Handle split cooling system and components carefully to prevent damage. Replace damaged rooftop units or components with new.

- B. Store split cooling system and components in clean dry place, off the ground, and protect from weather, water, and physical damage.
- C. Rig outdoor units to comply with manufacturer's rigging and installation instructions for unloading outdoor units, and moving them to final location.

1.06 SCHEDULING AND SEQUENCING

- A. Coordinate installation of outdoor unit sleepers with roof structure.
- B. Coordinate roof-opening locations for mechanical and electrical connections.

1.07 SPECIAL WARRANTY

- A. Warranty on Compressor: Provide written warranty, agreeing to replace/repair, including all parts and labor within warranty period, compressors with inadequate and defective materials and workmanship, including leakage, breakage, improper assembly, or failure to perform a required provided manufacturer's instructions for handling, installing, protecting, and maintaining units have been adhered to during warranty period.
- B. Warranty period shall be for a period of one year from the agreed start of the District's beneficial use.
- C. Extended warranty period. Provide written warranty signed by manufacturer, agreeing to replace components parts only, for an additional four (4) years for all hermetically sealed compressors.

1.08 MAINTENANCE

- A. Extra Materials: Furnish to District, with receipt, the following spare parts for each split cooling system:
 - 1. One set new filters for each unit set.

PART 2 PRODUCTS

2.01 ACCEPTABLE MANUFACTURERS

- A. Provide product of one of the following manufacturers:
 - 1. Carrier Corp.
 - 2. York

2.02 SPLIT COOLING SYSTEM (GENERAL)

- A. Split cooling only and heat pump system shall be factory assembled and tested, consist of an indoor, wall mounted direct expansion fan coil unit and an outdoor roof mounted, air cooled unit with a hermetic compressor, an air cooled coil, up-blast propeller type blow-through condenser fans, accumulator, holding refrigerant charge, and control box.

2.03 INDOOR UNIT

- A. General: Indoor, direct-expansion, wall-mounted or ceiling-mounted fan coil. Unit shall be complete with coil, fan, fan motor, piping connectors, electrical controls, microprocessor control system, integral temperature sensing, and a holding charge of R-410A refrigerant. Unit shall be furnished with integral wall-mounting or ceiling-mounting bracket.
- B. Unit Cabinet: Cabinet discharge and inlet grilles shall be attractively styled, high-impact polystyrene.
- C. Fan: Shall be tangential blower type with air intake at the upper front face of the unit and discharge at the bottom front. Automatic motor-driven horizontal air sweep shall be provided standard.

- D. Coil: Shall be copper tube with aluminum fins and galvanized steel tube sheets. Fins will be bonded to the tubes by mechanical expansion. A drip pan under the coil shall have a drain connection for hose attachment to remove condensate.
- E. Motors: Shall be permanently lubricated with inherent overload protection. Fan motors shall be multi-speed.
- F. Controls: Shall consist of a microprocessor-based control system that shall control space temperature, determine optimum fan speed, and run self-diagnostics. The unit shall have:
 - 1. An automatic restart after power failure at the same operating conditions as at failure.
 - 2. A timer function to provide a minimum 15-hour timer cycle for system on or off.
 - 3. Temperature-sensing controls and a high discharge temperature shut down.
 - 4. Wired control or wireless infrared control to enter set points and operating controls (required accessory).
 - 5. Filter status indication after 250 hours of indoor fan operation.
 - 6. Test mode button to run self-diagnostics and aid in troubleshooting.
- G. Filters: Unit shall have filter track with factory-supplied cleanable filter.

2.04 OUTDOOR UNIT

- A. General: Factory assembled, single piece, air-cooled outdoor unit. Contained within the unit enclosure shall be all factory wiring, piping, controls, compressor, and holding charge of R-410A refrigerant.
- B. Unit Cabinet:
 - 1. Unit cabinet shall be constructed of galvanized steel, bonderized and coated with a baked enamel finish.
 - 2. Unit access panels shall be removable with minimal screws and shall provide full access to the compressor, fan, and control components.
 - 3. Compressor compartment shall be isolated and have an acoustic lining to assure quiet operation.
- C. Fans:
 - 1. Condenser fans shall be direct-drive propeller type, discharging air horizontally, and blowing air through the condenser coil.
 - 2. Condenser fan motors shall be totally enclosed, single-phase motors with class B insulation and permanently lubricated ball bearings. Motor shall be protected by internal thermal overload protection.
 - 3. Shaft shall have inherent corrosion resistance.
 - 4. Fan blades shall be corrosion resistant and shall be statically and dynamically balanced.
 - 5. Condenser fan openings shall be equipped with PVC grille cover and screen protection grille.
- D. Compressor:
 - 1. Compressor shall be fully hermetic reciprocating or scroll type.
 - 2. Compressor shall be equipped with oil system, operating oil charge, and motor. Internal overloads shall protect the compressor from over temperature and current. Scroll compressors shall also have high discharge gas temperature protection.
 - 3. Motor shall be NEMA rated class F, suitable for operation in a refrigerant atmosphere.
 - 4. Reciprocating compressors shall be equipped with crankcase heaters to minimize liquid refrigeration accumulation in compressor during shut down and to prevent refrigerant dilution of oil.
 - 5. Compressor assembly shall be installed on rubber vibration isolators and shall have internal spring isolation.
- E. Condenser Coil: Shall be constructed of aluminum fins mechanically bonded to internally enhanced, seamless copper tubes that are cleaned, dehydrated, and sealed.

- F. Refrigeration Components: Refrigerant circuit components shall include external liquid line service valve with service port, suction line service valve with service gage connection port, service port connections on compressor suction and discharge lines with Schrader-type fittings, 4-way valve on heat pumps, accumulator, filter drier, pressure relief, and a holding charge of refrigerant.
- G. Controls and Safeties: Operating controls and safeties shall be factory selected, assembled, and tested. The minimum control function shall include:
 - 1. Controls:
 - a. Time delay restart to prevent compressor short cycling.
 - b. Automatic restart on power failure.
 - c. Three-pole contactors on 3-phase units.
 - d. Safety lockout.
 - e. High and low pressure switches.
 - f. Automatic fan motor protection.
 - g. Start capacitor and relay only on single-phase units.
 - h. When heat pump units are matched with high wall and ceiling suspended units, defrost control shall be based on demand determined by the outdoor air temperature and the coil temperature.
 - 2. Safeties:
 - a. High temperature protection.
 - b. System diagnostics.
 - c. Compressor motor current and temperature overload protection.
 - d. High-pressure relief.
 - e. Condenser fan failure protection.
- H. Electrical Requirements:
 - 1. Unit electrical power shall be a single point connection.
 - 2. Unit control voltage to the indoor fan coil shall be 24V.

PART 3 EXECUTION

3.01 EXAMINATION

- A. Examine areas and conditions under which split cooling system is to be installed. Do not proceed with work until unsatisfactory conditions have been corrected in manner acceptable to Installer.

3.02 INSTALLATION

- A. General: Install split cooling system in accordance with manufacturer's installation instructions. Install units plumb and level, firmly anchored in locations indicated, and maintain manufacturer's recommended clearances.
- B. Support: Install and secure redwood sleepers to roof structure, in accordance with National Roofing Contractor's Association (NRCA) installation recommendations and shop drawings.
- C. Electrical Connections: Refer to Division-26 Electrical Connections for Equipment for final connections to equipment and installation of loose-shipped electrical components.

3.03 DEMONSTRATION

- A. Provide the services of a qualified service representative to start-up split cooling system in accordance with manufacturer's written start-up instructions. Test controls and demonstrate compliance with requirements. Replace damaged or malfunctioning controls and equipment.
- B. Provide two, 1-hour training sessions for staff/operations and maintenance. One session before beneficial occupancy, and one session within 3 months after beneficial occupancy.

END OF SECTION

S

S
E
C
T
I
O
N
2
2
0
5
0
0

C
O
M
M
O
N
W
O
R
K
R
E
S
U
L
T
S
F
O
R
P
L
U

1.01 RELATED DOCUMENTS

- A. Drawings and general provisions of Contract, including General and Supplementary Conditions and Division 01 Specification Sections, apply to this and the other sections of Division 22.
- B. This Division is an integrated whole comprising interrelated and interdependent Section and shall be considered in its entirety in determining requirements of the Work.
- C. Refer to other sections of this Division for additional requirements or information regarding the subjects of this Section.

1.02 SECTION INCLUDES

- A. This Section includes general administrative and procedural requirements for mechanical installations. The following administrative and procedural requirements are included in this Section to expand the requirements specified in Division 01:
 - 1. Submittals.
 - 2. Coordination drawings.
 - 3. Record documents.
 - 4. Maintenance manuals.
 - 5. Rough-ins.
 - 6. Plumbing installations.
 - 7. Cutting and patching.

1.03 DESCRIPTION

- A. Provide a complete and operable installation, including all labor, supervision, materials, equipment, tools, apparatus, transportation, warehousing, rigging, scaffolding and other equipment and services necessary to accomplish the work in accordance with the intent and meaning of these drawings and specifications

1.04 DEFINITIONS

- A. "Provide" means furnish, install and connect unless otherwise described in specific instances.
- B. "Piping" means pipes, fittings, valves and all like pipe accessories connected thereto.
- C. "Ductwork" means ducts, plenums, compartments, or casings including the building structure, which are used to convey or contain air.
- D. "Extend", "Submit", "Repair" and similar words mean that the Contractor (or his designated subcontractor) shall accomplish the action described.
- E. "Codes" or "Code" means all codes, laws, statutes, rules, regulations, ordinances, orders, decrees, and other requirements of all legally constituted authorities and public utility franchise holders having jurisdiction.
- F. "Products", "Materials" and "Equipment" are used interchangeably and mean materials, fixtures, equipment, accessories, etc.
- G. "Utility Areas" are defined as mechanical, electrical, janitorial, and similar rooms or spaces which are normally used or occupied only by custodial or maintenance personnel. "Public Areas" are defined as the rooms or spaces, which are not included in the utility areas definition.
- H. "Building Boundary" includes concrete walkways immediately adjacent to the building structure.
- I. "Below Grade" means buried in the ground.
- J. "Substantial Mechanical Completion" means all components of all systems are functioning but lacking in final adjustment.
- K. Pressure rating specified (such as for valves and the like) means design working pressure for and with references to the fluid, which the device will serve.

1.05 RELATED WORK

- A. Coordination: Refer to Architectural, Civil, Structural, and Electrical Drawings for the construction details and coordinate the work of this Division with that of other Divisions. Order the work of this Division so that progress will harmonize with that of other Divisions and all work will proceed expeditiously. The work of this Division shall include direct responsibility for the correct placing and connection of mechanical work in relation to the work of other Divisions.
- B. Examine other Divisions for work related to the Work of this Division, especially Electrical.

1.06 EXISTING CONDITIONS

- A. Visit the site prior to bidding and investigate the existing conditions, which affect or will be affected by the work of this Division. Become thoroughly familiar with the working conditions and take into account any special or unusual features peculiar to this job. By the act of submitting a Bid, the Contractor will be deemed to have complied with the foregoing, to have accepted such conditions, and to have made allowance therefore in preparing his Bid.
- B. The locations of existing concealed utility lines are shown in accordance with reference data received by the Architect. The Architect does not guarantee the accuracy of such data. The points of connection are therefore approximate and the Bidder shall include adequate funds in his Bid to cover costs of connection regardless of their exact location.
- C. Exercise extreme caution during trenching operations. Repair the damage caused by such operations to existing utility lines at no cost to the Owner, whether the lines are shown on drawings or not.

1.07 DRAWINGS AND SPECIFICATIONS

- A. These drawings and specifications do not include necessary components for construction safety.
- B. All provisions shall be deemed mandatory except as expressly indicated as optional by the word "may" or "option".
- C. Except where dimensioned, the drawings relating to this division are a diagrammatic presentation of the design concept, which indicates the general area where piping and ductwork is to be run. The drawings do not necessarily indicate any and all offsets and configurations required for coordination with other trades. The contractor is responsible for the correct placing of his work, and the proper location and connection of his work in relation to the work of other trades.

1.08 PERMITS AND INSPECTIONS

- A. Obtain, schedule and pay for permits, licenses, approvals, tests, and inspections required by legally constituted authorities and public utility franchise holders having jurisdiction over the work.
- B. Afford the Architect's representative every facility for evaluating the skill and competence of the mechanics and to examine the materials. Concealed work shall be reopened when so directed during his periodic visits.

1.09 CODES AND REGULATIONS

- A. By submitting a Bid, Contractor is deemed to represent himself as competent to accomplish the work of this Division in conformance with applicable Codes. In case of conflict between the Contract Documents and Code requirements, the Codes shall take precedence.
conflicts appear, cease work on the parts of the contract affected and immediately notify the Architect in writing. It shall be the Contractor's responsibility to correct, at no cost to the Owner, any work he executes in violation of Code requirements. Specific references to codes elsewhere in this Division are either to aid the Contractor in locating applicable information or to deny him permission to use options, which are permitted by Codes.
- B. Applicable Codes: (Current editions unless otherwise noted)
 - 1. All local codes; city and/or county as applicable.
 - 2. OSHA requirements
 - 3. California Code of Regulations (CCR) Titles (as applicable)
 - 4. Fire Marshal Regulations
 - 5. State, County, City Health Department Ordinances and Regulations
 - 6. Regulations of all other authorities having jurisdiction.

- 7. California Mechanical Code.
 - 8. California Plumbing Code.
 - C. Where conflict or variation exists amongst Codes, the most stringent shall govern.
- 1.10 SUBMITTALS
- A. General: Follow the procedures specified in Division 01.
 - B. Mechanical Submittals: Increase the number of mechanical related shop drawings, product data, and samples submitted to allow for required distribution by one additional copy, which will be retained by the Mechanical Consulting Engineer.
 - C. Product Data: Assemble "product data" into tabbed brochures according to main areas of work i.e. Fire Protection; Plumbing; H.V.A.C.; Temperature Control; Testing, Adjusting, and Balancing.
 - 1. Assemble each brochure with tabbed separators for each Specification Section where products are noted to be submitted, with separate tabs for each product listed.
 - 2. Temperature "control shop drawings" may be submitted separately after preparations for review.
 - 3. For items such as valves, hangers and accessories, indicate specific items and where they are to be used.
 - 4. Contractor need only to submit for review those items specified to be submitted, unless requested by the Architect for special review.
 - D. Submit for review, only the specific items required in this Section or other Sections of Division 22.
 - E. Additional submittals shall include, but not limited:
 - 1. Air balance reports and equipment data record drawings.
 - 2. Certification of completion of testing.
 - 3. Certification of completion of operation instructions.
 - 4. Operating instruction brochure.
 - 5. Maintenance instruction brochures.
 - 6. Equipment guarantees.
 - 7. 1/4" = 1'-0" or larger scale layouts of "Equivalent" equipment or "Or Approved Equal" equipment.
 - 8. Coordination Drawings, where requested or required.
 - F. Submittal materials will be reviewed for substantial conformity with the intent of the contract plans and specifications only. Such review does not indicate approval of dimensions, quantities, coordination with other trades, or work methods of the contractor, which are indicated thereon.
 - G. Additional copies may be required by individual sections of these specifications.

1.11 COORDINATION

- A. The Contractor shall be responsible for coordinating the layout of all building elements to avoid conflict of the work of the structural, mechanical, electrical systems, and architectural features of the building.
- B. The cost of any extra work of any kind caused by a conflict due to this lack of coordination shall be borne by the Contractor.
- C. Contractor shall designate an individual competent and versed in the mechanical trades to coordinate the mechanical work with the work of other trades.

1.12 COORDINATION OF DRAWINGS

- A. Prepare coordination drawings in accordance with Division 01 to a scale of 1/4" = 1'-0" or larger; detailing major elements, components, and systems of mechanical equipment and materials in relationship with other systems, installations, and building components. Indicate locations where space is limited for installation and access and where sequencing and coordination of the installations are of importance to the efficient flow of the Work, including but not necessarily limited to the following:

1. Indicate the proposed locations of piping, ductwork, equipment, and materials. Include the following:
 - a. Clearances for servicing and maintaining equipment, including tube removal, filter removal, and space for equipment disassembly required for periodic maintenance.
 - b. Equipment for connections and support details.
 2. Prepare reflected ceiling plans to coordinate and integrate installations, air outlets and inlets, light fixtures, communication systems components, sprinklers, and other ceiling-mounted items.
- B. Submittal of "Or Approved Equal" substitutions of equipment will not be reviewed unless accompanied by coordination drawings.

1.13 RECORD AND DOCUMENTATION

- A. Prepare record documents in accordance with the requirements in Division 01. In addition to the requirements specified in Division 01, indicate the following installed conditions:
1. Record as specified in Division 01 the locations and invert elevations of underground installations.
 2. Accumulate the following and deliver to the Owner's representative prior to final acceptance of the work.
 3. Record (As-Built) Drawings:
 - a. Maintain in good order in the field office a complete set of prints for all work being done under Division 15. Update the drawings daily with neat and legible annotations in red ink showing the work as actually installed.
 - b. The actual size, location and elevation of all buried lines, valve boxes, manholes, monuments, and stub-outs shall be accurately located and dimensioned from building walls or other permanent landmarks.
 - c. Furnish the originals.
 4. Operation and Maintenance Manual: Furnish an operation and maintenance manual covering the stipulated mechanical systems and equipment. Seven copies of the manual, bound in hardback binders or an approved equivalent shall be provided to the Architect.
 5. Furnish one complete manual prior to the time that system or equipment tests are performed.
 6. Furnish the remaining manuals before the contract is completed.
 7. The following identification shall be inscribed on the cover: OPERATION AND MAINTENANCE MANUAL
PROJECT TITLE
CONTRACTOR
 8. Provide a table of contents. Insert tab sheets to identify discrete subjects. Instruction sheets shall be legible and easily understood, with large sheets of drawings folded in. The manual

shall be complete in all respects for all materials, piping, valves, devices and equipment, controls, accessories and appurtenances stipulated. Include as a minimum the following:

- a. Updated approved materials lists, shop drawings and catalog information of all items of mechanical system equipment.
- b. System layout showing piping, valves and controls.
- c. Wiring and control diagrams with data to explain detailed operation and control of each component.
- d. A control sequence describing start-up, operation and shutdown.
- e. Detailed description of the function of each principal component of the system.
- f. Procedure for starting.
- g. Procedure for operating.
- h. Shut-down instructions.
- i. Installation instructions.
- j. Adjustments, maintenance and overhaul instructions.
- k. Lubrication schedule including type, grade, temperature range and frequency.
- l. Safety precautions, diagrams and illustrations.
- m. Test procedures.
- n. Performance data.

- o. Parts list, with manufacturer's names and catalog numbers.
 - p. Preventive maintenance schedule.
 - q. Service organization with name, address and telephone number.
 - r. Valve identification chart and schedule.
 - s. ASME certificates.
 - t. Air balance report.
 - u. Hydronic balance report.
- B. Standards Compliance: Where equipment or materials are specified to conform with requirements of standards of recognized technical or industrial organizations such as American National Standards Institute (ANSI) American Society for Mechanical Engineers (ASME) American Society of Heating, Refrigeration and Air Conditioning Engineers (ASHRAE), American Society for Testing and Materials (ASTM), Underwriters Laboratories (UL), American Gas Association (AGA), American Refrigeration Institute (ARI), or National Electrical Manufacturer's Association (NEMA), that use a label or published listing as a method of indicating compliance, proof of such conformance shall be submitted and approved. The label or listing of the specified organization will be acceptable evidence.
 - C. Certificates of Conformance or Compliance: Submit original and not pre-printed certifications. Do not make statements in the certifications that could be interpreted to imply that the product does not meet all requirements.
 - D. Certified Test Reports: Certified Test Reports are reports of tests conducted on previously manufactured materials or equipment identical to that proposed for use. Before delivery of materials and equipment, submit certified copies of test reports specified in the individual sections.
 - E. Factory Tests: Factory tests are tests, which are required to be performed on the actual materials or equipment, proposed for use. Submit results of the tests in accordance with the requirements for laboratory test results of this Contract.
 - F. Permits and Certificates of Inspection: Furnish the originals.
 - G. Testing procedures and test results required in this and other sections. Furnish 2 copies.
 - H. Other data required by other sections of this Division. Furnish 2 copies.

1.14 MAINTENANCE MANUALS

- A. Prepare maintenance manuals in accordance with Division 01.

1.15 DELIVERY, STORAGE, AND HANDLING

- A. Deliver products to the project properly identified with names, model numbers, types, grades, compliance labels, and other information needed for identification.

1.16 EQUIVALENT EQUIPMENT

- A. These specifications and/or drawings names and specifies certain equipment in detail. It also names equivalent equipment by manufacturer, which is not considered to be a "substitution".
- B. Submit equivalent equipment to the Architect for review per the requirements of Division 01, and Section "Basic Mechanical Requirements."
- C. Equipment of Manufacturers named in Division 22 will be considered equivalent to that specified in detail and/or named on the drawings if:
 - 1. The proposed equipment is of equivalent quality, capacity.
 - 2. Equipment is as fully equipped, fits the space allotted, and has physical configuration and weight similar to the equipment specified in detail.
- D. A complete lay out of an equipment room or area must be submitted for equivalent equipment. Notice space limitations. Layouts to include plans and section views at a scale of not less than 1/4" = 1 ft.
- E. The Architect shall determine the acceptability of "Equivalent Equipment."

1.17 CONSTRUCTION COST BREAK DOWN

- A. Prepare and submit for review a construction cost breakdown for the major subdivisions of the mechanical work in accordance with General and Supplemental Conditions and Division 1.
- B. Subdivide each item on the breakdown into two headings: labor and materials. Include overhead and profit in each entry.
- C. Submit one copy of the breakdown directly to the Engineer and the remaining copies sent through regular channels.

1.18 TOOLS

- A. Provide all special tools needed for proper operation and routine adjustment and maintenance of systems and equipment. Deliver tools to Owner's representative and request a receipt for same.

1.19 WARRANTIES

- A. Refer to Division 1 Section for procedures and submittal requirements for warranties. Refer to individual equipment specifications for warranty requirements.
- B. Where periods more than one year are specified in the specifications, such longer periods shall govern. However, when any component fails at any time during this period, the warranty period for such component and all other components, which are inactive because of, said failure shall be suspended. The warranty period for such components shall resume running for the remaining portion of the warranty period when failed component is completely repaired and in operation; however, in no case shall the resumed portion of the warranty period be less than 3 months in duration.
- C. Neither payment for work, nor total or partial occupancy of work by the Owner, within or prior to the warranty period specified, shall be construed as acceptance of faulty work or shall condone any negligence or omission of Contractor in doing the work.
- D. Compile and assemble the warranties specified in Division 15, into a separated set of vinyl covered, three ring binders, tabulated and indexed for easy reference.
- E. Provide complete warranty information for each item to include product or equipment to include date of beginning of warranty or bond; duration of warranty or bond; and names and addresses, and telephone numbers and procedures for filing a claim and obtaining warranty services.

1.20 SEISMIC RESTRAINT

- A. Provide seismic restraint for mechanical equipment, piping, and ductwork.
- B. Contractor shall submit certification of suitability of seismic restraint methods signed by Structural Engineer registered in State of California.
- C. Contractor may refer to details applicable in the SMACNA, "GUIDELINES FOR SEISMIC RESTRAINT OF MECHANICAL SYSTEMS", using the 'g' forces for "other buildings" classification CCR Title 24. Deliver a copy of these Guidelines to the Owner's Resident Inspector.

1.21 SYSTEM OPERATIONAL TEST

- A. The Contractor shall inform the Owner in writing one week prior to starting this testing in order that the Owner's representative may be present.
- B. After balancing and prior to final inspection, the contractor shall operate all systems continuously trouble free and stable for a minimum period of fourteen (14) consecutive days including Saturday and Sunday. Each day shall be a minimum of an 8-hour day. Should a problem arise, the fourteen (14) day period shall be restarted and repeated until successfully operated for full 14 days. A written report certified by the Owner's representative shall indicate the successful completion of a stable and trouble free 14-day period.

PART 2 PRODUCTS

2.01 MATERIALS AND EQUIPMENT

- A. Standard Products: Materials and equipment shall be essentially the standard cataloged products of manufacturers regularly engaged in production of such materials or equipment and shall be their latest standard designs that comply with the specification requirements.
- B. Materials and equipment shall duplicate items that have been in satisfactory commercial or industrial use at least two years prior to bid opening, unless more stringent requirements are specified. Where two or more units of the same type of equipment are required, these units shall be products of a single manufacturer. The components thereof, however, are not required to be exclusively of the same manufacturer.
- C. Each major component of equipment shall have manufacturer's name, address, model, and serial number on a nameplate securely affixed in a conspicuous place. The nameplate of the distributing agent will not be acceptable.
- D. Whenever on the plans, or in these specifications, products are identified by the name of one manufacturer, it is intended that equivalent products of other manufacturers are acceptable, unless otherwise indicated, if accepted as a substitution by the Architect.
- E. Where three or more manufacturers are listed as "acceptable manufacturers" however, then the products furnished shall be the product of one of the manufacturers listed. Manufacturers listed as "acceptable manufacturers" shall be considered "Equivalents" and shall meet quality and performance of a particular one specified by both name and catalog number.

2.02 PRODUCT LISTING

- A. When two or more items of same material or equipment are required (plumbing fixtures, pumps, valves, air conditioning units, etc.) they shall be of the same manufacturer. Product manufacturer uniformity does not apply to raw materials, bulk materials, pipe, tube, fittings (except flanged and grooved types), sheet metal, wire, steel bar stock, welding rods, solder, fasteners, motors for dissimilar equipment units, and similar items used in Work, except as otherwise indicated.

2.03 NAMEPLATE DATA

- A. Provide permanent operational data nameplate on each item of power operated mechanical equipment, indicating manufacturer, product name, model name, serial number, capacity, operating and power characteristics, labels of tested compliances, and similar essential data. Locate nameplates in an accessible location.

2.04 SUBSTITUTIONS

- A. General: Submittals of "Substitutions" shall be in accordance with requirements of Division 1.
- B. By proposing a substitution, it is deemed that the Contractor shall bear the cost of any changes (whether architectural, structural, electrical or mechanical) necessary to accommodate the substitution, if said substitution is accepted.
- C. Specific: Refer to other sections of this Division for additional requirements.

2.05 SUBMITTALS

- A. General: Make submittals in accordance with requirements of Division 1.
- B. Specific: Refer to other sections of this Division for additional requirements.

PART 3 EXECUTION

3.01 WORKMANSHIP AND INSTALLATION METHODS

- A. Workmanship shall be in the best standard practice of the trade.
- B. Install equipment in accordance with the manufacturer's instructions and recommendations unless otherwise noted or specified.

3.02 TEST

- A. General:
 1. Demonstrate that all components of the work of this Division have been provided and that they operate in accordance with the Contract Documents.
 2. Provide instruments and personnel for tests and demonstrations. Submit signed test results.
- B. Specific: Refer to the other sections of this Division for test requirements.

3.03 ROUGH-IN

- A. Verify final locations for rough-ins with field measurements and with the requirements of the actual equipment to be connected.
- B. Refer to equipment specifications in Divisions 02 through 23 for rough-in requirements.

3.04 MECHANICAL INSTALLATIONS

- A. General: Sequence, coordinate, and integrate the various elements of mechanical systems, materials, and equipment. Comply with the following requirements:
 1. Coordinate mechanical systems, equipment, and materials installation with other building components.
 2. Verify all dimensions by field measurements.
 3. Arrange for chases, slots, and openings in other building components during progress of construction, to allow for mechanical installations.
 4. Coordinate the installation of required supporting devices and sleeves to be set in poured-in-place concrete and other structural components, as they are constructed.
 5. Sequence, coordinate, and integrate installations of mechanical materials and equipment for

efficient flow of the Work. Give particular attention to large equipment requiring positioning prior to closing in the building.

6. Where mounting heights are not detailed or dimensioned, install systems, materials, and equipment to provide the maximum headroom possible.
7. Coordinate connection of mechanical system with exterior underground and overhead utilities and services. Comply with requirements of governing regulations, franchised service companies, and controlling agencies. Provide required connection for each service.
8. Install systems, materials, and equipment to conform with approved submittal data, including coordination drawings, to greatest extent possible. Conform to arrangements indicated by the Contract Documents, recognizing that portions of the Work are shown only in diagrammatic form. Where coordination requirements conflict with individual system requirements, refer conflict to the Architect.
9. Install systems, materials, and equipment level and plumb, parallel and perpendicular to other building systems and components, where installed exposed in finished spaces.
10. All mechanical equipment to facilitate servicing, maintenance, and repair or replacement of equipment components in full compliance with the equipment manufacturer's recommendations. If the drawings or the manufacturer does not provide a specific space requirement for servicing equipment, provide as a minimum, horizontal distance of 36" from face of equipment to opposite vertical surface.
11. Install access panels or doors, in sizes large enough to allow adequate access for testing and maintenance, where units are concealed behind finished surfaces.
12. Install systems, materials, and equipment giving right-of-way priority to systems required to be installed at a specified slope.
13. Any equipment located above a ceiling that has any component which is serviceable shall be installed within 12" of the top of the ceiling, and so that all components are accessible.

3.05 CUTTING AND PATCHING

- A. General: Perform cutting and patching in accordance with Division 01. In addition to the requirements specified in Division 01, the following requirements apply:
 1. Protection of Installed Work: During cutting and patching operations, protect adjacent installations.
- B. Perform cutting, fitting, and patching of mechanical equipment and materials required to:

1. Uncover Work to provide for installation of ill-timed Work.
 2. Remove and replace defective work.
 3. Remove and replace Work not conforming to requirements of the Contract Documents.
 4. Remove samples of installed Work as specified for testing.
 5. Install equipment and materials in existing structures.
 6. Upon written instructions from the Architect, uncover and restore Work to provide for Architect/Engineer/Inspector observation of concealed Work.
- C. Cut, remove and legally dispose of selected mechanical equipment, components, and materials as indicated, including but not limited to removal of mechanical piping, heating units, plumbing fixtures and trim, and other mechanical items made obsolete by the new Work.
- D. Protect the structure, furnishings, finishes, and adjacent materials not indicated or scheduled to be removed.
- E. Provide and maintain temporary partitions or dust barriers adequate to prevent the spread of dust and dirt to adjacent areas.
- F. Patch existing finished surfaces and building components using experienced installers and new materials matching existing materials. For installer's qualifications refer to the materials and methods required for the surface and building components being patched.
- 3.06 DELIVERY, HANDLING, STORAGE OF MATERIALS AND PROTECTION OF WORK
- A. Protect materials against dirt, water, chemical and mechanical damage both while in storage and during construction.
 - B. Cover materials in such a manner that no finished surfaces will be damaged, marred or splattered with plaster or paint, and all moving parts will be kept clean and dry.
 - C. Replace or refinish any damaged materials including fronts of control panels, ductwork fittings, and shop-fabricated ductwork.
 - D. Keep cabinets and other openings closed to prevent entry of foreign matter.
 - E. Specific: Refer to other sections of this Division for additional requirements.
- 3.07 PROJECT CONDITIONS
- A. Check and coordinate for clearance, accessibility and placement of equipment either by going through openings provided or by placing equipment during construction. Ordering of equipment to be shipped disassembled, or disassembly of equipment at Project Site and reassembly of equipment to accomplish this requirement shall be executed without additional cost. Where provided openings are inadequate to accommodate equipment, provide new openings and restoration of same, all at no additional cost. Obtain written approval for new openings before proceeding.
 - B. Verify location of all plumbing fixtures and equipment within finished spaces with the Architectural Drawings. In the event that Mechanical Drawings do not indicate exact locations, or are in conflict with the Architectural Drawings, obtain information regarding proper locations. Installation of work without proper instruction under such circumstances will result in relocation of work, when directed, without additional cost.
- 3.08 INSTRUCTION TO OWNER PERSONNEL
- A. When specified in other sections, the Contractor shall furnish, without additional expense to the Owner, the services of competent instructors who will give full instruction to the designated personnel in the adjustment, operation, and maintenance, including pertinent safety requirements, of the equipment or system specified. Each instructor shall be thoroughly familiar with all parts of the installation and shall be trained in operating theory as well as practical operation and maintenance of work. Instruction shall be given at the Owner's convenience. The number of man-days (eight-hours) of instruction furnished shall be as specified in other sections. When more than four man-days of instruction are specified, approximately half of the time shall be used for classroom instruction. All other time shall be used for instruction with the equipment or system. When significant changes or modifications are made under the terms of the contract,

provide additional instructions to acquaint the operating personnel with the changes or modifications.

- B. Contractor shall electronically record, both visual and audio, instruction to Owner's personnel on the maintenance and operation of the mechanical systems.
- C. Submit certification, signed by Owner's agent that instructions have been completed and the electronic record has been reviewed and delivered to the Owner.
- D. Printed operating instructions and a copy of wiring diagrams are to be mounted in all equipment areas, framed and behind glass or encased in plastic. Printed operating instructions shall include steps for starting up and securing equipment. As a precedent to final acceptance four (4) copies of instructions are to be submitted to the Architect for review. Contractor shall turn over to Owner in a neat brochure form, equipment guarantee and maintenance instructions.

3.09 CLEANING

- A. Cleaning shall be done as the work proceeds. Periodically remove waste and debris to keep the site as clean as is practical.
- B. Refer to the Division 01 Sections for general requirements for final cleaning.
- C. Leave exposed parts of the mechanical work in a neat, clean and usable condition, with painted surfaces unblemished and plated metal surfaces polished.
- D. Thoroughly clean all materials, equipment and appliances. Clean and prepare all surfaces to be painted. Clean the entire premises of unused materials, debris, spots and marks to the satisfaction of the Architect and District Representative.
- E. Remove, thoroughly clean and replace all strainers and automatic valves after the system has been put in operation until system is clear of all foreign matter and repeat this operation after ten (10) days and again after the system has been in operation thirty (30) days. Submit certification that this operation has been completed.

3.10 SAFETY REQUIREMENTS

- A. Enclose and guard belts, pulleys, chains, gears, couplings, projecting setscrews, keys, and other rotating parts in accordance with OSHA requirements. Insulate, guard, and cover any high-temperature equipment and piping so located as to endanger personnel or create a fire hazard.

END OF SECTION

SECTION 22 05 03

EARTHWORK FOR PLUMBING SYSTEMS

PART1 GENERAL

1.01 SECTION INCLUDES

- A. This Section includes limited scope instructions for methods and materials applicable to excavation for underground utilities and services, including underground piping under the building and from building to utility connection, tanks, basins, and equipment.

1.02 SUBMITTALS

- A. Submit schedules in accordance with Conditions of Contract and Divisions 01 and 22 specification sections.
 - 1. Indicate proposed methods and schedule of operations prior to commencement of work.
 - 2. Include coordination for shut off of utility services where required.
 - 3. Maintain services to areas outside construction limits, where such service exists.
 - 4. Coordinate sequencing with construction phasing and Owner occupancy specified in Division 01.

1.03 DEFINITIONS

- A. Excavation consists of removal of material encountered to sub-grade elevations indicated and subsequent disposal of materials removed.
- B. Unauthorized excavation consists of removal of materials beyond indicated sub-grade elevations or dimensions without specific direction of Architect. Unauthorized excavation, as well as remedial work directed by Architect, shall be at Contractor's expense.
- C. Sub-grade: The undisturbed earth or the compacted soil layer immediately below granular sub-base, drainage fill, or topsoil materials.
- D. Structure: Buildings, foundations, slabs, tanks, curbs, or other man-made stationary features occurring above or below ground surface.

1.04 CODES AND ORDINANCES

- A. Perform excavation work in compliance with applicable requirements of authorities having jurisdiction.

1.05 PROJECT CONDITIONS

- A. Conditions Affecting Excavations: The following project conditions apply:
 - 1. Maintain and protect existing building services which transit the area affected by selective demolition.
 - 2. Protect structures, utilities, sidewalks, pavements, and other facilities from damage caused by settlement, lateral movement, undermining, washout, and other hazards created by excavation operations.
- B. Site Information: Subsurface conditions were investigated during the design of the Project. Reports of these investigations are available for information only; data in the reports are not intended as representations or warranties of accuracy or continuity of conditions. The Owner will not be responsible for interpretations or conclusions drawn from this information.
- C. Existing Utilities: Locate existing underground utilities in excavation areas. If utilities are indicated to remain, support and protect services during excavation operations. Remove existing underground utilities indicated to be removed.
- D. Should uncharted, or incorrectly charted, piping or other utilities be encountered during excavation, consult utility owner immediately for directions. Cooperate with Owner and utility

companies in keeping respective services and facilities in operation. Repair damaged utilities to satisfaction of utility owner.

- E. Use of Explosives: Use of explosives is not permitted.

1.06 SEQUENCE AND SCHEDULING

- A. Coordinate the shut off and disconnection of utility services with Owner and utility company.
- B. Provide minimum of 48-hour written notice to Architect and Owner, and receive written approval confirmation, prior to any necessary utility interruption.

PART 2 PRODUCTS

2.01 MATERIALS

- A. Select Bedding Sand: Dry river bed sand free of any debris or organic matter.
- B. Mastic Coatings: "Henry's" oil base roof mastic.
- C. Polyethylene sheeting not less than 8 mils thick.

PART 3 EXECUTION

3.01 EXAMINATION

- A. Examine areas where earthwork is to occur. Determine extent of work and effect on existing conditions to remain. Advise Architect of any conditions that might create extensive alteration beyond indicated scope.
- B. Clearances: Take special notice and maintain the required horizontal and vertical depth clearances from structural footings for utility trenches running parallel to footings. Do not violate the area of the footing bearing prism. In the event of conflict (i.e., the utility cannot be relocated or its depth changed), proceed as directed by the Architect. Lower structural footings to maintain proper clearances for underground utilities trenching without additional cost to Owner.

3.02 EXCAVATION

- A. Slope sides of excavations to comply with local codes and ordinances. Shore and brace as required for stability of excavation.
- B. Shoring and Bracing: Establish requirements for trench shoring and bracing to comply with local codes and authorities. Maintain shoring and bracing in excavations regardless of time period excavations will be open.
 - 1. Remove shoring and bracing when no longer required. Where sheeting is allowed to remain, cut top of sheeting at an elevation of 30 inches below finished grade elevation.
- C. Install sediment and erosion control measures in accordance with local codes and ordinances.

3.03 DEWATERING

- A. Dewatering: Prevent surface water and subsurface or ground water from flowing into excavations and from flooding project site and surrounding area.
 - 1. Do not allow water to accumulate in excavations. Remove water to prevent softening of bearing materials. Provide and maintain dewatering system components necessary to convey water away from excavations.
 - 2. Establish and maintain temporary drainage ditches and other diversions outside excavation limits to convey surface water to collecting or run-off areas. Do not use trench excavations as temporary drainage ditches.

3.04 MATERIAL STORAGE

- A. Material Storage: Stockpile satisfactory excavated materials where directed, until required for backfill or fill. Place, grade, and shape stockpiles for proper drainage.

1. Locate and retain soil materials away from edge of excavations. Do not store within drip-line of trees indicated to remain.
2. Remove and legally dispose of excess excavated materials and materials not acceptable for use as backfill or fill.

3.05 TRENCHING

- A. Do all necessary trenching, excavation, shoring and backfilling required for the proper laying of the pipe lines.
- B. Pipe Trench Dimensions: The following requirements are considered minimal unless otherwise indicated, in order to provide adequate pipe clearances and bedding. Provide trenches wider than the specified minimum where required to properly install the particular type of piping. In the event utility company regulations, code requirements, or the pipe manufacturer's recommendations differ from these provisions, the most restrictive requirements shall take precedence:

1. Pipe Burial Depths:	
Sewer & Drainage:	24"(a) + pipe O.D.(b) + 3" bed of sand
Gas:	30" +pipe O.D. + 4" bed of sand
Water (Domestic)	
PVC:	30" + pipe O.D. + 4" bed of sand
All other:	24" (30" at planters)+ pipe O.D. + 4" bed of sand
Pre-insulated Piping	24" +jacket O.D. + 4" bed
Condenser Water (PVC)	30" + pipe O.D. + 4" bed

Notes:

- a. Finish grade to top of pipe, typical.
 - b. O.D.: Outside dimension.
2. Trench Widths:
- | | |
|--------------------|--|
| Sewer & Drainage: | 12" +pipe O.D. for 4" to 18" diameter pipe |
| Gas: | 8" + pipe O.D. |
| Water (Domestic) | 8" +pipe O.D. |
| Water (Fire) | |
| Pre-insulated Pipe | 8" +jacket O.D. |
| Condenser Water | 8" + pipe O.D. |

- C. Where rock is encountered, carry excavation below required elevation and backfill with a layer of select bedding sand prior to installation of pipe. Provide a minimum of 6 inches of stone or gravel cushion between rock bearing surface and pipe.
- D. Excavate trenches for piping and equipment with bottoms of trench to accurate elevations for support of pipe and equipment on undisturbed soil.
- E. Do not install copper piping or metal gas piping in a common trench with other dissimilar metal piping or conduit; separate a minimum of 4 feet when running parallel to such piping or conduit.
- F. Separate multiple parallel lines of piping in a common trench a minimum of 12 inches, both horizontally and vertically, between individual pipes.
- G. Install domestic water piping, running parallel in a common trench with sewer or drainage lines, on a solid shelf 12 inches above the sewer or drainage piping.
- H. Do not run electrical power and communications conduit in a common trench with sewer, drainage, water or gas piping.
- I. Provide and install a bare 14 gauge copper "tracer" wire, continuous for entire length, for all underground non-metallic piping. Secure to piping at alternate joints, at each fitting and at each valve. Locate "Tracer" wire along side pipe, but not under pipe.

- J. Install thrust blocks in all pressurized lines. Install thrust blocks in accordance with pipe manufacturer's recommendations.

3.06 EXCAVATION FOR UNDERGROUND CLARIFIERS AND STRUCTURES

- A. Excavation for Underground Tanks, Basins, and Mechanical Structures: conform to elevations and dimensions shown within a tolerance of plus or minus 0.10 foot; plus a sufficient distance to permit placing and removal of concrete formwork, installation of services, other construction, and for inspection.
 1. Excavate, by hand, areas within drip-line of large trees. Protect the root system from damage and dry-out. Maintain moist conditions for root system and cover exposed roots with burlap. Paint root cuts of 1 inch in diameter larger with emulsified asphalt tree paint.
 2. Take care not to disturb bottom of excavation. Excavate by hand to final grade just before concrete reinforcement is placed.

3.07 BACKFILLING AND FILLING

- A. Backfilling and Filling: Place soil materials in layers to required sub-grade elevations for each area classification listed below, using materials specified in Part 2 of this Section.
- B. Bedding: Lay and bed pipe in compacted select dry river-bed bedding sand, thickness as specified herein and backfill with the same sand material to a height of one foot above the top of pipe.
 1. Sewer drain lines except as hereinafter specified may be bedded in the native soil provided it is rock free and sandy. Dig out under bell portions of the piping for uniform bearing.
 2. Under walks and pavements, use a combination of sub-base materials and excavated or borrowed materials.
 3. Under building slabs, set piping on a 6-inch bed of dry river-bed sand and backfilled to 12" of finish grade with dry river-bed sand. Remainder of backfill to be approved backfill material.
 4. Under piping and equipment, use sub-base materials where required over rock bearing surface and for correction of unauthorized excavation.
 5. For piping less than 30 inches below surface of roadways, provide 4-inch-thick concrete base slab support. After installation and testing of piping, provide a 4-inch thick concrete encasement (sides and top) prior to backfilling and placement of roadway sub-base.
 6. Other areas, use excavated or borrowed materials.
- C. Backfill excavations as promptly as work permits, but not until completion of the following:
 1. Do not backfill until installation has been approved and as-built drawings are up to date.
 2. Inspection, testing, approval, and locations of underground utilities have been recorded.
 3. Removal of concrete formwork.
 4. Removal of shoring and bracing, and backfilling of voids.
 5. Removal of trash and debris.
- D. Placement and Compaction: Place backfill and fill materials in layers of not more than 8 inches in loose depth for material compacted by heavy equipment, and not more than 4 inches in loose depth for material compacted by hand-operated tampers.
- E. Before compaction, moisten or aerate each layer as necessary to provide optimum moisture content. Compact each layer to required percentage as specified in Division 02. Do not place backfill or fill material on surfaces that are muddy, frozen, or contain frost or ice.
- F. Place backfill and fill materials evenly adjacent to structures, piping, and equipment to required elevations. Prevent displacement of piping and equipment by carrying material uniformly around them to approximately same elevation in each lift.
- G. Cold Weather Protection: Protect excavation bottoms against freezing when atmospheric temperature is less than 35 deg. F.

H. Unauthorized excavation:

1. Under footings, foundation bases, or retaining walls, fill unauthorized excavation by extending indicated bottom elevation of footing or base to excavation bottom, without altering required top elevation. Lean concrete fill may be used to bring elevations to proper position, when acceptable to Architect.
2. In locations other than those above, backfill and compact unauthorized excavations as specified for authorized excavations of same classification, unless otherwise directed by Architect.

3.08 SUBSIDENCE

- A. Subsidence: Where subsidence occurs at mechanical installation excavations during the period 12 months after Substantial Completion, remove surface treatment (i.e., pavement, lawn, or other finish), add backfill material, compact to specified conditions, and replace surface treatment. Restore appearance, quality, and condition of surface or finish to match adjacent areas.

3.09 CORROSION PROTECTION

- A. All below ground metallic fittings, valves, flanges, bolts, pipes (which are not factory coated with a bituminous material) shall be protected against corrosion as follows:
1. All metallic components as described above shall receive a heavy coating of "Henry's" oil base roof mastic.
 2. After mastic coating is completed and inspected, wrap entire metallic component with a minimum of 8 mil polyethylene wrap overlapped 50% of the circumference and extended beyond ends of component as required for polyethylene to be secured to piping. The overlap seam shall be located to avoid backfill material from entering the encapsulated area. The ends and seam of the polyethylene material shall be secured to the piping and sealed with 3M Scotch/Wrap N. 50, 10 mil., 2" wide, printed, pipe wrap sealing tape.
 3. The mastic coating shall be inspected and approved prior to the finish application of the polyethylene material, which shall also be inspected.

END OF SECTION

SECTION 22 05 19

METERS AND GAGES FOR PLUMBING PIPING

PART 1 GENERAL

1.01 SECTION INCLUDES

- A. This Section includes the following types of meters and gages:
 - 1. Temperature gages and fittings.
 - 2. Pressure gages and fittings.
 - 3. Flow meters.
- B. Meters and gages furnished as part of factory-fabricated equipment are specified as part of equipment assembly in other Division 22 sections.

1.02 SUBMITTALS

- A. General: Submit the following in accordance with conditions of Contract and Division 01 Specification Sections and Section 22 05 00 "Common Work Result for Plumbing".
 - 1. Product data for each type of meter and gage. Include scale range, ratings. Submit meter and gage schedule showing manufacturer's figure number, scale range, location, and accessories for each meter and gage.
 - 2. Maintenance data for each type of meter and gage for inclusion in Operating and Maintenance Manuals specified in Division 01 and Division 22 Section "Common Work Results for Plumbing".

1.03 QUALITY ASSURANCE

- A. ASME and ISA Compliance: Comply with applicable portions of ASME and Instrument Society of America (ISA) standards pertaining to construction and installation of meters and gages.

PART 2 PRODUCTS

2.01 MANUFACTURERS

- A. Manufacturers: Subject to compliance with requirements, provide products by one of the following:
 - 1. Mercury-In-Glass Thermometers: a. Marshalltown Instruments, Inc. b. Terice (H.O.) Co. c. Weiss Instruments, Inc. d. Weksler Instruments Corp.
 - 2. Thermometer Wells: Same as for thermometers.
 - 3. Pressure Gages:
 - a. Ametek, U.S. Gauge Div.
 - b. Ashcroft Dresser Industries Instrument Div.
 - c. Marsh Instruments Co., Unit of General Signal.
 - d. Marshalltown Instruments, Inc.
 - e. Terice (H.O.) Co.
 - f. Weiss Instruments, Inc.
 - g. Weksler Instruments Corp.
 - h. WIKA Instruments Corp.
 - 4. Pressure Gage Accessories: Same as for pressure gages.
 - 5. Water Orifice-Type Measurement System:
 - a. Armstrong Pumps, Inc.
 - b. Bell & Gossett, ITT. Fluid Handling Div.
 - 6. Calibrated Balance Valves a. Armstrong Pumps, Inc. b. Bell and Gossett, ITT, Fluid Handling Div.
 - 7. Venturi-Type Flow Measurement System a. Armstrong Pumps, Inc.

- b. Barco Div., Marison Industries
- c. Gerand Engineering Co.

8. Test Plugs

- a. MG Piping Products Co.
- b. Peterson Equipment Co., Inc.
- c. Sisco, A Spedco, Inc. Co.
- d. Trerice (H.O.) Co.
- e. Watts Regulator Co.

2.02 THERMOMETERS, GENERAL

- A. Accuracy: Plus or minus 1 percent of range span or plus or minus one scale division to maximum of 1.5 percent of range span.
- B. Scale range: Temperature ranges for services listed as follows:
 - 1. Domestic Hot Water: 30 to 240 deg F with 2-degree scale divisions.
 - 2. Domestic Cold Water: 0 to 100 deg F with 2-degree scale divisions
 - 3. Heating Water: 30 to 300 deg F with 2-degree scale divisions
 - 4. Condenser Water: 0 to 160 deg F with 2-degree scale divisions
 - 5. Chilled Water: 0 to 100 deg F with 2-degree scale divisions
 - 6. Steam and Condensate: 50 to 400 Deg F with 2-degree scale divisions

2.03 MERCURY-IN-GLASS THERMOMETERS

- A. Case: Die cast, aluminum finished, in baked epoxy enamel, glass front, spring secured, 9 inches long.
- B. Adjustable Joint: Finished to match case, 180-degree adjustment in vertical plane, 360-degree adjustment in horizontal plane, with locking device.
- C. Tube: Red reading, mercury filled, magnifying lens.
- D. Scale: Satin-faced, non-reflective aluminum, with permanently etched markings.
- E. Stem: Copper-plated steel, aluminum or brass, for separable socket, length to suit installation.

2.04 THERMOMETER WELLS

- A. Thermometer Wells: Brass or stainless steel, pressure rated to match piping system design pressure; with 2-inch extension for insulated piping and threaded cap nut with chain permanently fastened to well and cap.

2.05 PRESSURE GAGES

- A. Type: General use, ASME B40.1, Grade A, phosphor bronze bourdon-tube type, bottom connection.
- B. Case: Drawn steel or brass, glass lens, 4-1/2-inches diameter.
- C. Connector: Brass, 1/4-inch NPS.
- D. Scale: White coated aluminum, with permanently etched markings.
- E. Accuracy: Plus or minus 1 percent of range span.
- F. Range: Conform to the following:
 - 1. Vacuum: 30" & 0-15 psi compound range; 1" and 1/2 psi graduations.
 - 2. Chilled and heating water systems, except as otherwise indicated: 0-60 psi range, 1 psi graduation.

3. Condenser water system, except as otherwise indicated: (0-15); (0-30) psi range, (1/4 psi); (1/2 psi) graduation.
4. Except as otherwise indicated: 0-100 psi range, 1 psi graduation.
5. High temperature water system: 0-300 psi range, 2 psi graduations.

2.06 PRESSURE GAGE ACCESSORIES

- A. Syphon: 1/4-inch NPS straight coil constructed of brass tubing with threads on each end.
- B. Snubber: 1/4-inch NPS brass bushing with corrosion-resistant porous metal disc. Disc material shall be suitable for fluid served and rated pressure.

2.07 FLOW METERS, GENERAL

- A. Flow rate of elements and meters shall be same as connected equipment or system.

2.08 WAFER ORIFICE-TYPE FLOW ELEMENTS

- A. Type: Differential-pressure wafer type orifice insert flow elements designed for installation between pipe flanges.
- B. Construction: Cast-iron body, brass valves with integral check readout valves and caps, and calibrated nameplate. Elements pressure rated for 300 psig and 250 degree F.

2.09 CALIBRATED BALANCE VALVE

- A. Type: Differential-pressure, ball type, adjustable orifice designed for installation in piping.
- B. Construction: Bronze body/brass ball construction with glass and carbon filled TFE seal rings, screwed connections with integral check readout valves and caps and calibrated nameplate and memory stop and drain connection. Elements pressure rated for 300 psig and 250 degree f.

2.10 VENTURI-TYPE FLOW ELEMENTS

- A. Type: Differential-pressure venturi-type, designed for installation in piping.
- B. Construction: Bronze or cadmium-plated steel with brass fittings and attached tag with flow conversion data. Ends shall be threaded for 2 inches and smaller elements and flanged or welded for 2-1/2 inches and larger elements.

2.11 PITOT TUBE-TYPE FLOW ELEMENTS

- A. Type: Differential-pressure pitot-tube type design with probe for insertion into piping.
- B. Construction: Stainless steel probe of length to span inside of pipe, with brass fittings and attached tag with flow conversion data. Elements shall be pressure rated for 150 psig and 250°F (120°C).

2.12 METERS

- A. Portable Meters: Differential-pressure gage and two 12-foot hoses in carrying case with handle.
- B. Scale: In inches of water unless otherwise indicated.
- C. Accuracy: Plus or minus 2 percent between 20 to 80 percent of range.
- D. Each meter shall be complete with operating instructions.

2.13 TEST PLUGS

- A. Test Plugs shall be nickel-plated brass body, with 1/2-inch NPS fitting and 2 self-sealing valve-type core inserts, suitable for inserting a 1/8-inch O.D. probe assembly from a dial-type thermometer or pressure gage. Test plug shall have gasket and threaded cap with retention chain and body of length to extend beyond insulation. Pressure rating shall be 500 psig.

- B. Core Material: conform to the following for fluids and temperature range:
- C. Air, Water, Oil, and Gas, 20 to 200° F: Neoprene.
- D. Test Kit: Provide test kit consisting of 1 pressure gage, gage adapter with probe, 2 bimetal dial thermometers, and carrying case.
- E. Ranges of pressure gage and thermometers shall be approximately 2 times systems operating conditions.

PART 3 EXECUTION

3.01 THERMOMETERS INSTALLATION

- A. Install thermometers in vertical and tilted positions to allow reading by observer standing on floor.
- B. Install in the following locations and elsewhere as indicated:
 1. At inlet and outlet of each hydronic zone.
 2. At inlet and outlet of each hydronic boiler and chiller.
 3. At inlet and outlet of each hydronic coil in air-handling units and built-up central systems.
 4. At inlet and outlet of each hydronic heat exchanger.
 5. At inlet and outlet of each hydronic heat recovery unit.
 6. At inlet and outlet of each thermal storage tank.
- C. Thermometer Wells: Install in piping tee where thermometers are indicated, in vertical position. Fill well with oil or graphite and secure cap.

3.02 INSTALLATION OF PRESSURE GAGES

- A. Install pressure gages in piping tee with pressure gage valve, located on pipe at most readable position.
- B. Install in the following locations, and elsewhere as indicated:
 1. At suction and discharge of each pump.
 2. At discharge of each pressure-reducing valve.
 3. At building water service entrance.
 4. At chilled water and condenser water inlets and outlets of chillers.
- C. Pressure Gage Needle Valves: Install in piping tee with snubber. Install syphon in lieu of snubber for steam pressure gages.

3.03 INSTALLATION OF TEST PLUGS

- A. Test Plugs: Install in piping tee where indicated, located on pipe at most readable position. Secure cap.

3.04 INSTALLATION OF FLOW-MEASURING ELEMENTS AND METERS

- A. Locations: Install flow measuring elements in the following locations and elsewhere as indicated.
 1. At discharge of each pump.
 2. At inlet of each hydronic coil in built-up central systems.
- B. Differential-Pressure-Type Flow Elements: Install minimum straight lengths of pipe upstream and downstream from element as described by the manufacturer's installation instructions.
- C. Install wafer orifice-type element between 2 Class 125 pipe flanges, ANSI B16.1 (cast iron) or ANSI B16.24 (bronze).
- D. Install connections for attachments to portable flow meters in a readily accessible location.

3.05 INSTALLATION OF CALIBRATED BALANCE VALVES

- A. Install calibrated balance valves in the following locations and elsewhere as indicated.
 - 1. At each fan coil unit.
 - 2. At each unitary water source heat-pump.
 - 3. At each 3-way valve.

3.06 ADJUSTING AND CLEANING

- A. Adjusting: Adjust faces of meters and gauges to proper angle for best visibility.
- B. Cleaning: Clean windows of meters and gages and factory-finished surfaces. Replace cracked and broken windows, and repair scratched and marred surfaces with manufacturer's touch-up paint.

3.07 CONNECTIONS

- A. Piping installation requirements are specified in other sections of Division 22. The drawings indicate the general arrangement of piping, fittings, and specialties. The following are specific connection requirements:
- B. Install meters and gages piping adjacent to machine to allow servicing and maintaining of machine.

END OF SECTION

SECTION 22 05 23

GENERAL-DUTY VALVES FOR PLUMBING PIPING

PART 1 GENERAL

1.01 RELATED SECTIONS

- A. Division 22 Section "Identification for Plumbing Piping and Equipment" for valve tags and charts.

1.02 SECTION INCLUDES

- A. This Section includes general duty valves common to most mechanical piping systems.
 - 1. Special purpose valves are specified in individual piping system specifications.

1.03 SUBMITTALS

- A. General: Submit the following in accordance with Conditions of Contract, Division 01 Specification Sections, and Section 22 05 00 "Common Work Results for Plumbing."
 - 1. Product data, including body material, valve design, pressure and temperature classification, end connection details, seating materials, trim material and arrangement, dimensions and required clearances, and installation instructions.
 - 2. Provide valve schedule showing manufacturer's figure numbers and sizes.

1.04 QUALITY ASSURANCE

- A. Single Source Responsibility: Comply with the requirements specified in Division 01 Section "Materials and Equipment," under "Source Limitations."
- B. American Society of Mechanical Engineers (ASME) Compliance: Comply with ASME B31.9 for building services piping and ASME B31.1 for power piping.
- C. Manufacturer's Standardization Society of the Valve and Fittings Industry (MSS) Compliance: Comply with the various MSS Standard Practices referenced.

1.05 DELIVERY, STORAGE, AND HANDLING

- A. Preparation for Transport: Prepare valves for shipping as follows:
 - 1. Ensure valves are dry and internally protected against rust and corrosion.
 - 2. Protect valve ends against damage to threads, flange faces, and weld-end preps.
 - 3. Set valves in best position for handling. Set globe and gate valves closed to prevent ratting; set ball and plug valves open to minimize exposure of functional surfaces; and block swing check valves in either closed or open position.
- B. Storage: Use the following precautions during storage:
 - 1. Do not remove valve end protectors unless necessary for inspection; then reinstall for storage.
 - 2. Protect valves from weather. Store valves indoors. Maintain valve temperature higher than the ambient dew point temperature. If outdoor storage is necessary, support valves off the ground or pavement in watertight enclosures.

PART 2 PRODUCTS

2.01 MANUFACTURERS

- A. Manufacturer: Subject to compliance with requirements, provide products from one of the manufacturers listed in valve schedule.

2.02 VALVE FEATURES, GENERAL

- A. Valve Design: Rising stem or rising outside screw and yoke stems.
 - 1. Non-rising stem valves may be used where headroom prevents full extension of rising stems.

- B. Pressure and Temperature Ratings: As scheduled and required to suit system pressures and temperatures.
- C. Sizes: Same size as upstream pipe, unless otherwise indicated.
- D. Operators: Provide the following special operator features:
 - 1. Hand wheels, fastened to valve stem, for valves other than quarter turn.
 - 2. Lever handles, on quarter-turn valves 6-inches and smaller, except for plug valves. Provide plug valves with square heads; provide one wrench for every 10 plug valves.
 - 3. Chain-wheel operators, for valves 2-1/2 inch and larger, install 72 inches or higher above finished floor elevation. Extend chains to an elevation of 5'-0" above finished floor elevation. a. Provide gear drive operators, on quarter-turn valves 8-inch and larger.
- E. Extended Stems: Where insulation is indicated or specified provide extended stems arranged to receive insulation.
- F. End Connections: As indicated in the valve specifications.
 - 1. Threads: Comply with ANSI B1.20.1.
 - 2. Flanges: Comply with ANSI B16.1 for cast iron, ANSI B16.5 for steel, and ANSI B16.24 for bronze valves.
 - 3. Solder-Joint: Comply with ANSI B16.18.
 - a. Caution: Where soldered end connections are used, use solder having a melting point below 840 deg. F for gate, globe, and check valves; below 421 deg. F for ball valves.

2.03 GATE VALVES

- A. Gate Valves, 2-Inch and Smaller: MSS SP-80; Class 150, body and union bonnet of ASTM B62 cast bronze; with threaded or solder ends, solid disc, copper-silicon alloy stem, brass packing gland, "Teflon" impregnated packing, and malleable iron hand wheel. Do not use solder end valves for hot water heating or steam piping applications.

MANUFACTURER	THREADED NRS	THREADED RS	SOLDER NRS	SOLDERS
Crane	X	431UB	X	X
Grinnell	3050	3060	X	X
Milwaukee	1141	1151	X	1169
Nibco	T-136	T-135	S-136	X
KITZ	X	42	X	43

"X" means not available.

- B. Gate Valves, 2-1/2 Inch and Larger: MSS SP-70; Class 125 iron body, bronze mounted, with body and bonnet conforming to ASTM A126 class B; with flanged ends, "Teflon" impregnated packing, and two-piece backing gland assembly.

MANUFACTURER	OS&YRS	NRS
Crane	465-1/2	461
Grinnell	6020A	6060A

Nibco	617-0	F-619
Milwaukee	F-2885	F-2882
KITZ	72	75

2.04 BALL VALVES

- A. Ball Valves, 2 Inches and Smaller: Rated for 150 psi saturated stem pressure, 400 psi WOG pressure; two- or three-piece construction; with bronze body conforming to ASTM B 62, full port only, chrome-plated brass ball, replaceable "Teflon" or "TFE" seats and seals, blowout-proof stem, and vinyl covered steel handle. Provide solder ends for condenser water, chilled water, and domestic hot and cold water service; threaded ends for heating hot water and low-pressure steam.

Ball Valves - 1 Inch and Smaller:

MANUFACTURER	THREADED ENDS	SOLDER ENDS
Conbraco (Apollo)	70-100	70-200
Crane	9302	9322
Nibco	T-580-70	S-580-70
Stockham	S-216 BR-R-T	S-216-BR-R-S
Watts	B-6000	B-6001
Milwaukee	BA-100	BA-150
KITZ	58	59

"X" means not available.

Ball Valves- 1-1/4 Inch to 2 Inch:

MANUFACTURER	THREADED ENDS	SOLDER ENDS
Conbraco (Apollo)	82-100	82-200
Nibco	T-590-Y	S-590-Y
Stockham	S-216 BR-R-T	S-216-BR-R-S
Watts	B-6800	B-6801
KITZ	62	63

"X" means not available.

- B. For grooved end connections, use Victaulic Style 721.
- 2.05 PLUG VALVES

- A. Plug Valves, 2-Inch and Smaller: Rated at 150 psi WOG; bronze body, with straightaway pattern, square head, and threaded ends.

1. Lunkenheimer: 454 or equal.
2. Homestead: 611 (Semi Steel Body) or equal.

B. Plug Valves, 2-1/2 Inch and Larger: MSS SP-78; rated at 175 psi WOG; lubricated plug type, with semi steel body, single gland, wrench operated and flanged ends.

1. Powell: 2201 or equal.
2. Homestead: 605 or equal.

2.06 GLOBE VALVES

A. Globe Valves, 2-Inch and Smaller: MSS SP-80; Class 125; body and screwed bonnet of ASTM B 62 cast bronze; with threaded or solder ends, brass or replaceable composition disc, copper-silicon alloy stem, brass packing gland, "Teflon" impregnated packing, and malleable iron hand wheel. Provide Class 150 valves meeting the above where system pressure requires.

CLASS 125 MANUFACTURER	CLASS 125 THREADED	CLASS 150 SOLDER_	THREADED
Crane	1	1310	17TF
Milwaukee	502	1502	590
Nibco	T-211-B T-211-Y	S-211-B S-211-Y	T-235-Y
KITZ	11	12	10

B. Globe Valves, 2-1/2-Inch and Larger: MSS SP-85; Class 125 iron body and bolted bonnet conforming to ASTM A 126, Class B; with outside screw and yoke, bronze mounted, flanged ends, and "Teflon" impregnated packing, and two-piece backing gland assembly.

MANUFACTURER	STRAIGHT BODY	ANGLE BODY
Crane	351	353
Milwaukee	F2981	F2986
Nibco	F-718-B	F-818-B
KITZ	76	X

2.07 BUTTERFLY VALVES

- A. General - Where butterfly valves are used as shutoff for termination, or equipment removal or repair, select ductile iron lug type valves, bi-directional, dead-end service rated to the full working pressure of the valve. Select wafer type valves for other applications. Provide gear operators on butterfly valves 8" and larger. Valve bodies to have extended necks to provide for 2-1/4" insulation as needed. Butterfly valves 12 inch and smaller rated to 200 psi, 14 inch and larger 150 psi.

Butterfly Valves 2-1/2 Inches and Larger:

The following are model numbers for wafer-type, with nickel-plated ductile-iron disc:

MANUFACTURER	LEVER	GEAR
Crane	12	12
Nibco	WD-20103	WD-20105
Milwaukee	MW-222E	MW-322E
KITZ	DJ Series	DJ Series

Grooved Ends: Victaulic Style 300 and 704.

The following are model numbers for lug-type, with nickel-plated ductile-iron disc:

MANUFACTURER	LEVER	GEAR
Crane	14	14
Nibco	LD-20103	LD-20105
Milwaukee	ML-222E	ML-322E
KITZ	DJ Series	DJ Series

Grooved Ends: Victaulic Style 300 and 704.

The following are model numbers for wafer-type, with aluminum-bronze disc:

MANUFACTURER	LEVER	GEAR
Crane	42	42
Nibco	WD-20003	WD-20005
Milwaukee	CW-223E	CW-323E
KITZ	DJ Series	DJ Series

Grooved Ends: Vic taulic Style 300A, 700A, and 703A.

The following are model numbers for lug-type, with aluminum-bronze disc:

MANUFACTURER	LEVER	GEAR
Center Line	Series LT	Series LT
Crane	44	44
Nibco	LD-20003	LD-20005
Milwaukee	CL-223E	CL-323E
KITZ	DJ Series	DJ Series

Grooved Ends: Victaulic Style 300A, 700A, and 703A.

2.08 CHECK VALVES

- A. Swing Check Valves, 2-Inch and Smaller: MSS SP-80; Class 125, cast-bronze body and cap conforming to ASTM B 62; with horizontal swing, Y-pattern, and bronze disc; and having threaded or solder ends. Provide valves capable of being reground while the valve remains in the line. Provide Class 150 valves meeting the above specifications, with threaded end connections, where system pressure requires or where Class 125 valves are not available.

MANUFACTURER	CLASS 125 THREADED ENDS	CLASS 125 SOLDER ENDS	CLASS 125 THREADED ENDS
Crane	37	1342	137
Milwaukee	509	1509	510
Nibco	T-413	S-413	T-433
KITZ	22	23	29

For grooved connections, use Victaulic Style 712.

- B. Swing Check Valves, 2-1/2 Inch and Larger: MSS SP-71; Class 125 (Class 175 FM approved for fire protection piping systems), cast iron body and bolted cap conforming to ASTM A 126, Class B; horizontal wing, and bronze disc or cast-iron disc with bronze disc ring; and flanged ends. Provide valves capable of being refitted while the valve remains in the line.

MANUFACTURER	CLASS 125	CLASS 175
Crane	373	X
Milwaukee	F2974	X
Nibco	F-918	X
KITZ	78	X

For grooved connections, use Victaulic Series 712.
 "X" means not available.

- C. Lift Check Valves, 2-Inch and Smaller: Class 125; cast-bronze body and cap conforming to ASTM B 62; horizontal or angle pattern, lift-type valve, with stainless steel spring, bronze disc holder with renewable "Teflon" disc, and threaded ends. Provide valves capable of being refitted and ground while the valve remains in the line.

MANUFACTURER	HORIZONTAL	ANGLE
Jenkins	655-A	X
Lunkenheimer	233	X

"X" means not available.

PART 3 EXECUTION

3.01 EXAMINATION

- A. Examine valve interior through the end ports for cleanliness, freedom from foreign matter, and corrosion. Remove special packing materials, such as blocks used to prevent disc movement during shipping and handling.
- B. Actuate valve through an open-close and close-open cycle. Examine functionally significant features, such as guides and seats made accessible by such actuation. Following examination, return the valve closure member to the shipping position.
- C. Examine threads on both the valve and the mating pipe for form (i.e., out-of-round or local indentation) and cleanliness.
- D. Examine mating flange faces for conditions that might cause leakage. Check bolting for proper size, length, and material. Check gasket material for proper size, material composition suitable for service, and freedom from defects and damage.
- E. Prior to valve installation, examine the piping for cleanliness, freedom from foreign materials, and proper alignment.

3.02 VALVE ENDS SELECTION

- A. Select valves with the following ends or types of pipe/tube connections:
 1. Copper Tube Size, 2-Inch and Smaller: Solder ends, except provide threaded ends for heating hot water and low-pressure steam service.
 2. Steel Pipe Sizes, 2-Inch and Smaller: threaded or grooved end.
 3. Steel Pipe Sizes 2-1/2 Inch and Larger: grooved end or flanged.

3.03 VALVE INSTALLATIONS

- A. General Application: Refer to piping system specification sections for specific valve applications and arrangements. Use gate, ball, and butterfly valves for shut-off duty. Use globe, plug, and ball valves for throttling duty.
- B. Locate valves for easy access and provide separate support where necessary. Where concealed, install behind access panel with valve located for complete accessibility for servicing.
- C. Install valves and unions for each fixture and item of equipment. Arrange valves to allow equipment removal without system shutdown. Unions are not required on flanged devices.
- D. Install three-valve bypass around each pressure reducing valve using throttling-type valves.

- E. Install valves in horizontal piping with stem at or above the center of the pipe.
- F. Install valves in a position to allow full stem movement.
- G. Installation of Check Valves: Install for proper direction of flow as follows:
 - 1. Swing Check Valves: Horizontal position with hinge pin level.
 - 2. Lift Check Valve: With stem upright and plumb.
- H. Where shut-off valves are installed in a confined space such as in a wall or furring, install ball valves with operating handle parallel with face of wall.
- I. Where valves are located in walls, do not install more than 6'-0" from finished floor. Where valves are located above ceiling, install valve centered on access point and not greater than 24" above access point.

3.04 SOLDER CONNECTIONS

- A. Cut tube square and to exact lengths, and ream tube and remove burrs to restore full inside diameter of tube/pipe.
- B. Clean end of tube to depth of valve socket with steel wool, sand cloth, or a steel wire brush to a bright finish. Clean valve socket in same manner.
- C. Apply proper soldering flux in an even coat to inside of valve socket and outside of tube.
- D. Open gate and globe valves to full open position.
- E. Remove the cap and disc holder of swing check valves having composition discs.
- F. Insert tube into valve socket, making sure the end rests against the shoulder inside valve. Rotate tube or valve slightly to ensure even distribution of the flux.
- G. Apply heat evenly to outside of valve around joint until solder will melt upon contact. Feed solder until it completely fills the joint around tube. Avoid hot spots or overheating valve. Once the solder starts cooling, remove excess amounts around the joint with a cloth or brush.
- H. Use 95-5 tin/antimony solder for all solder joints unless indicated otherwise.

3.05 THREADED CONNECTIONS

- A. Note the internal length of threads in valve ends, and proximity of valve internal seat or wall, to determine how far pipe should be threaded into valve.
- B. Align threads at point of assembly.
- C. Apply appropriate tape or thread compound to the external pipe threads (except where dry seal threading is specified).
- D. Assemble joint, wrench tight. Wrench on valve shall be on the valve end into which the pipe is being threaded.

3.06 FLANGED CONNECTIONS

- A. Align flange surfaces parallel.
- B. Assemble joints by sequencing bolt tightening to make initial contact of flanges and gaskets as flat and parallel as possible. Use suitable lubricants on bolt threads. Tighten bolts gradually and uniformly with a torque wrench.

3.07 FIELD QUALITY CONTROL

- A. Tests: After piping systems have been tested and put into service, but before final adjusting and balancing, inspect valves for leaks. Adjust or replace packing to stop leaks; replace valves if leak persists.

3.08 ADJUSTING AND CLEANING

- A. Cleaning: Clean mill scale, grease, and protective coatings from exterior of valves and prepare valves to receive finish painting or insulation.

3.09 VALVE PRESSURE/TEMPERATURE CLASSIFICATION SCHEDULES

- A. Below schedules are for standard installation conditions. Variations or special valves and/or conditions set forth in other Division 22 Sections shall take precedence.
VALVES. 2-INCH AND SMALLER

SERVICE	GATE	GLOBE	BALL	CHECK
Condenser Water	125	125	150	125
Chilled Water	125	125	150	125
Domestic Hot and Cold Water	125	125	150	125
Heating Hot Water	150	150	150	150
Low-Pressure Steam	150	150	150	150

VALVES. 2-1/2 INCH AND LARGER

SERVICE	GATE	GLOBE	BUTTERFLY	CHECK
Condenser	125	125	200	125
Chilled Water	125	125	200	125
Domestic Hot and Cold Water	125	125	200	125
Heating Hot Water	125	125	200	125
Low-Pressure Steam	125	125	200	125

END OF SECTION

SECTION 22 05 29

HANGERS AND SUPPORTS FOR PLUMBING PIPING AND EQUIPMENT

PART1 GENERAL

1.01 SECTION INCLUDES

- A. Extent of supports and anchors required by this section is indicated on drawings or in other Division-22 sections and include the following:
 - 1. Horizontal-Piping Hangers and Supports;
 - 2. Vertical-Piping Clamps;
 - 3. Hanger-Rod Attachments;
 - 4. Building Attachments;
 - 5. Saddles and Shields;
 - 6. Miscellaneous Materials;
 - 7. Anchors;
 - 8. Equipment Supports.

1.02 RELATED SECTIONS

- A. This section is part of each Division-22 section making reference to or requiring supports and anchors specified herein.
- B. Supports and anchors furnished as part of factory-fabricated equipment are specified as part of equipment assembly in other Division-22 sections.
- C. Section: Cast-in-Place Concrete.

1.03 QUALITY ASSURANCE

- A. Codes and Standards:
 - 1. Code Compliance: Comply with applicable plumbing codes pertaining to product materials and installation of supports and anchors.
 - 2. UL and FM Compliance: Provide products which are UL-listed and FM approved.
 - 3. MSS Standard Compliance:
 - a. Provide pipe hangers and supports of which materials, design, and manufacturer comply with MSS SP-58.
 - b. Select and apply pipe hangers and supports, complying with MSS SP-69.
 - c. Fabricate and install pipe hangers and supports, complying with MSS SP-89.
 - d. Terminology used in this section is defined in MSS SP-90.

1.04 SUBMITTALS

- A. Product Data: Submit manufacturer's technical product data, including installation instructions for each type of support and anchor.

PART 2 PRODUCTS

2.01 MANUFACTURED UNITS

- A. Hangers and support components shall be factory fabricated of materials, design, and manufacturer complying with MSS SP-58.
 - 1. Components shall have galvanized coatings where installed for piping and equipment that will not have field-applied finish.
 - 2. Pipe attachments shall have nonmetallic coating for electrolytic protection where attachments are in direct contact with copper tubing.

- B. Thermal Hanger Shield Inserts: 100-psi average compressive strength, waterproofed calcium silicate, encased with a sheet metal shield. Insert and shield shall cover entire circumference of the pipe and shall be of length indicated by manufacturer for pipe size and thickness of insulation.

2.02 HORIZONTAL-PIPING HANGERS AND SUPPORTS

- A. General: Except as otherwise indicated, provide factory fabricated horizontal-piping hangers and supports complying with MSS SP-58, of one of the following MSS types listed, selected by Installer to suit horizontal-piping systems, in accordance with MSS SP-69 and manufacturer's published product information. Use only one type by one manufacturer for each piping service. Select size of hangers and supports to exactly fit pipe size for bare piping, and to exactly fit around piping insulation with saddle or shield for insulated piping. Provide copper-plated hangers and supports for copper-piping systems.
 1. Adjustable Steel Clevis Hangers: MSS Type 1.
 2. Adjustable Swivel Pipe Rings: MSS Type 6.

2.03 VERTICAL-PIPING CLAMPS

- A. General: Except as otherwise indicated, provide factory fabricated vertical-piping clamps complying with MSS SP-58, of one of the following types listed, selected by Installer to suit vertical piping systems, in accordance with MSS SP-69 and manufacturer's published product information. Select size of vertical piping clamps to exactly fit pipe size of bare pipe. Provide copper-plated clamps for copper-piping systems.
- B. Two-Bolt Riser Clamps: MSS Type 8.

2.04 HANGER-ROD AND BUILDING ATTACHMENTS

- A. General Hanger Rod Attachment: Refer to structural drawings for requirements of hanger rod and building attachments. If a specific attachment that is required is not detailed on the structural drawings, one of the following attachments may be submitted for review by the structural engineer prior to installation. Except as otherwise indicated, provide factory fabricated hanger-rod attachments complying with MSS SP-58, of one of the following MSS types listed, selected by Installer to suit horizontal-piping hangers and building attachments, in accordance with MSS SP-69 and manufacturer's published product information. Use only one type by one manufacturer for each piping service. Select size of hanger-rod attachment to suit hanger rods. Provide copper-plated hanger-rod attachments for copper-piping systems.
- B. General Building Attachment: Except as otherwise indicated, provide factory fabricated building attachments complying with MSS SP-58, of one of the following MSS types listed, selected by Installer to suit building substrate conditions, in accordance with MSS SP-69 and manufacturer's published product information. Select size of building attachments to suit hanger rods. Provide copper-plated building attachments for copper-piping systems.
 3. Concrete Inserts: MSS Type 18.
 4. Center Beam Clamps: MSS Type 21.
 5. Steel Beam Clamps W/Eye Nut: MS Type 28.
 6. Linked Steel Clamps W/Eye Nut: MSS Type 29.
 7. Malleable Beam Clamps: MSS Type 30.
 8. Steel Brackets: One of the following for indicated loading:
 9. Light Duty: MSS Type 31.

2.05 SADDLES AND SHIELDS

- A. General: Except as otherwise indicated, provide saddles or shields under piping hangers and supports, factory-fabricated, for all insulated piping. Size saddles and shields for exact fit to mate with pipe insulation.

- B. Protection Shields: MSS Type 40; provide high density insert of same thickness of insulation.

2.06 MANUFACTURERS OF HANGERS AND SUPPORTS

- A. Manufacturers: Subject to compliance with requirements, provide hangers and supports of one of the following:
 1. B-Line Systems, Inc.
 2. Talco, Inc.
 3. Eleen Metal Products Co.
 4. Fee & Mason Mfg. Co.; Div. Figgie International.
 5. ITT Grinnel Corp.

2.07 MISCELLANEOUS MATERIALS

- A. Steel Plates, Shapes and Bars: ASTM A36.
- B. Cement Grout: Portland cement (ASTM C150, Type I or Type III) and clean uniformly graded, natural sand (ASTM C 404, Size No. 2). Mix at a ratio of 1.0 part cement to 3.0 parts sand, by volume, with minimum amount of water required for placement and hydration.
- C. Pipe Alignment Guides: Factory fabricated, of cast semi-steel or heavy fabricated steel, consisting of bolted two-section outer cylinder and base with two-section guiding spider that bolts tightly to pipe. Length of guides shall be as recommended by manufacturer to allow indicated travel.
- D. Pipe Roll Stand: Factory fabricated cast iron stand, size as required, with insulation installed on piping.

2.08 ISOLATORS

- A. Isolators: Provide factory-fabricated isolators of size required.
- B. Spring Isolators: Refer to Section 23 05 48 Vibration and Seismic Control for HVAC.
- C. Manufacturers: Refer to Section 23 05 48 Vibration and Seismic Control for HVAC.

PART 3 EXECUTION

3.01 INSPECTION

- A. Examine substrates and conditions under which supports and anchors are to be installed. Do not proceed with installation until unsatisfactory conditions have been corrected.

3.02 PREPARATION

- A. Proceed with installation of hangers, supports and anchors only after required building structural work has been completed in areas where the work is to be installed. Correct inadequacies including (but not limited to) proper placement of inserts, anchors and other building structural attachment.
- B. Prior to installation of hangers, supports, anchors and associated work, installer shall meet at project site with Contractor, installer of each component of associated work, inspection and testing agency representatives (if any), installers of other work requiring coordination with work of this section and Architect/Engineer for purpose of reviewing material selections and procedures to be followed in performing the work in compliance with requirements specified.

3.03 INSTALLATION OF BUILDING ATTACHMENTS

- A. Install building attachments at required locations within concrete or on structural steel for proper piping support. Space attachments within maximum piping span length indicated in MSS SP-69. Install additional building attachments where support is required for additional concentrated loads, including valves, flanges, guides, strainers, expansion joints, and at changes in direction

of piping. Install concrete inserts before concrete is placed; fasten insert securely to forms. Where concrete with compressive strength less than 2500 psi is indicated, install reinforcing bars through openings at top of inserts.

3.04 INSTALLATION OF HANGERS AND SUPPORTS

- A. General: Install hangers, supports, clamps and attachments to support piping properly from building structure; comply with MSS SP-69. Arrange for grouping of parallel runs of horizontal piping to be supported together on trapeze type hangers where possible. Install supports with maximum spacing complying with MSS SP-69. Where piping of various sizes is to be supported together by trapeze hangers, space hangers for smallest pipe size or install intermediate supports for smaller diameter pipe. Do not use wire or perforated metal to support piping, and do not support piping from other piping.
- B. Install hangers and supports complete with necessary inserts, bolts, rods, nuts, washers and other accessories. Except as otherwise indicated for exposed continuous pipe runs, install hangers and supports of same type and type as installed for adjacent similar piping.
- C. Prevent electrolysis in support of copper tubing by use of hangers and supports which are copper plated, or by other recognized industry methods.
- D. Provisions of Movement: Install hangers and supports to allow controlled movement of piping systems and to permit freedom of movement between pipe anchors.
- E. Load Distribution: Install hangers and supports so that piping live and dead loading and stresses from movement will not be transmitted to connected equipment.
- F. Pipe Slopes: Install hangers and supports to provide required pipe slopes, and so that maximum pipe deflections allowed by ANSI B31 Pressure Piping Codes are not exceeded.
- G. Bare Piping: Install isolators for all bare domestic water and bare hydronic piping.
- H. Insulated Piping: Comply with the following installation requirements.
 - 1. Clamps: Attach clamps, including spacers (if any), to piping with clamps projecting through insulation; do not exceed pipe stresses allowed by ANSI B31.
 - 2. Shields: Where low-compressive-strength insulation or vapor barriers are indicated on cold or chilled water piping, install coated protective shields. Provide rigid insulation reinforcement at shields.
- I. Hangers and supports to be capable to resist the minimum seismic forces indicated in drawings.

3.05 EQUIPMENT SUPPORTS

- A. Concrete housekeeping bases will be provided as work of Division 03.
- B. Furnish to Contractor, scaled layouts of all required bases, with dimensions of bases, and location to column center lines. Furnish templates, anchor bolts, and accessories, necessary for base construction.

3.06 ADJUSTING AND CLEANING

- A. Hanger Adjustment: Adjust hangers so as to distribute loads equally on attachments.
- B. Support Adjustment: Provide grout under supports so as to bring piping and equipment to proper level and elevations.
- C. Cleaning: Clean factory-finished surfaces. Repair any marred or scratched surfaces with manufacturer's touch-up paint.
- D. Touch-Up Painting: Immediately after erection of anchors and supports, clean field welds and abraded areas of shop paint and paint exposed areas with same material as used for shop painting to comply with SSPC-PA-1 requirements for touch-up of field-painted surfaces.

1. Apply by brush or spray to provide a minimum dry film thickness of 2.0 mils.
- E. For galvanized surfaces clean welds bolted connections and abraded areas and apply galvanizing repair paint to comply with ASTM A- 780.

END OF SECTION

SECTION 22 05 53

IDENTIFICATION FOR PLUMBING PIPING AND EQUIPMENT

PART1 GENERAL

1.01 SECTION INCLUDES

- A. Extent of mechanical identification work required by this section is indicated on drawings or specified in other Division-22 sections, and includes the following:
 - 1. Painted Identification Materials
 - 2. Plastic Pipe Markers
 - 3. Plastic Tape
 - 4. Underground-Type Plastic Line Marker
 - 5. Plastic Duct Markers
 - 6. Valve Tags
 - 7. Diagram and Schedule Frames
 - 8. Engraved Plastic-Laminate Signs
 - 9. Plastic Equipment Markers
 - 10. Plasticized Tags
 - 11. Equipment Marker

1.02 RELATED SECTIONS

- A. This section makes reference to identification devices specified herein.
- B. Mechanical identification furnished as part of factory-fabricated equipment, is specified as part of equipment assembly in other Division-22 sections.
- C. Refer to Division-26 Sections for identification requirements of electrical work; not work of this section.

1.03 SUBMITTALS

- A. Product Data: Submit manufacturer's technical product data and installation instructions for each identification material and device required.
- B. Samples: Submit samples of each color, lettering style and other graphic representation required for each identification material or system.
- C. Schedules and Diagrams:
 - 1. Submit valve schedule for each piping system, typewritten and reproduced on 8-1/2" x 11" bond paper. Tabulate valve number, piping system, system abbreviation (as shown on tag), location of valve (room or space), and variations for identification (if any). Mark valves which are intended for emergency shut-off and similar special uses, by special "flags", in margin of schedule.
 - 2. Submit temperature control diagrams and Sequence of Operation on bond paper suitable for framing.
- D. Maintenance Data: Include product data and schedules in maintenance manuals; in accordance with requirements of Division 01 and Division 22, Section 22 05 00.

1.04 QUALITY ASSURANCE

- A. Codes and Standards:
 - 1. ANSI Standards: Comply with ANSI A13.1 for lettering size, length of color field, colors, and viewing angles of identification devices.
 - 2. No adhesive type identification markers will be accepted. All markers and tags shall be permanently attached to pipe, etc.
- 3. All identification markers installed exterior of buildings shall be ultra-violet resistant. PART 2 PRODUCTS

2.01 ACCEPTABLE MANUFACTURERS

- A. Manufacturer: Subject to compliance with requirements, provide mechanical identification materials of one of the following:
 1. Allen Systems, Inc.
 2. Brady (W.H.) Co.; Signmark Div.
 3. Industrial Safety Supply Co., Inc.
 4. Seton Name Plate Corp.

2.02 MECHANICAL IDENTIFICATION MATERIALS

- A. General: Provide manufacturer's standard products of categories and types required for each application as referenced in other Division-22 sections. Where more than a single type is specified for application, selection is Installer's option, but provide a single selection for each product category.

2.03 PLASTIC PIPE MARKERS

- A. Snap-On Type: Provide manufacturer's standard pre-printed, semi-rigid snap-on, color-coded pipe markers, complying with ANSI A13.1.
- B. Insulation: Furnish 1" thick molded fiberglass insulation with jacket for each plastic pipe marker to be installed on un-insulated pipes subject to fluid temperatures of 125oF (52oC) or greater. Cut length to extend 2" beyond each end of plastic pipe marker.
- C. Small Pipes: For external diameters less than 6" (including insulation if any), provide full-band pipe markers, extending 360 degrees around pipe at each location, fastened by one of the following methods:
 1. Snap-on application of pre-tensioned semi-rigid plastic pipe marker.
 2. Laminated or bonded application of pipe marker to pipe (or insulation).
 3. Taped to pipe (or insulation) with color-coded plastic adhesive tape, not less than 3/4" wide; full circle at both ends of pipe marker, tape lapped 1-1/2".
- D. Large Pipes: For external diameters of 6" and larger (including insulation if any), provide either full-band or strip-type pipe markers, but not narrower than 3 times letter height (and of required length), fastened by one of the following methods:
 1. Laminated or bonded application of pipe marker to pipe (or insulation).
 2. Taped to pipe (or insulation) with color-coded plastic adhesive tape, not less than 1-1/2" wide; full circle at both ends of pipe marker, taped lapped 3".
 3. Strapped-to-pipe (or insulation) application of semi-rigid type, with manufacturer's standard stainless steel bands.
- E. Lettering: Manufacturer's standard pre-printed nomenclature which best describes piping system in each instance, as selected by Architect/Engineer in cases of variance with names as shown or specified.
 1. Arrows: Print each pipe marker with arrows indicating direction of flow, either integrally with piping system service lettering (to accommodate both directions), or as a separate unit of plastic.

2.04 PLASTIC TAPE

- A. General: Provide manufacturer's standard color-coded pressure-sensitive (self-adhesive) vinyl tape, not less than 3 mils thick.
- B. Width: Provide 1-1/2" wide tape markers on pipes with outside diameters (including insulation, if any) of less than 6", 2-1/2" wide tape for larger pipes.

- C. Color: Comply with ANSI A13.1, except where another color selection is indicated.

2.05 UNDERGROUND-TYPE PLASTIC LINE MARKER

- A. General: Manufacturer's standard permanent, bright-colored, continuous-printed plastic tape, intended for direct-burial service; not less than 6" wide x 4 mils thick. Provide tape with printing which most accurately indicates the type of service of buried pipe.
 - 1. Provide multi-ply tape consisting of solid aluminum foil core between 2-layers of plastic tape.

2.06 VALVE TAGS

- A. Brass Valve Tags: Provide 19-gage polished brass valve tags with stamped-engraved piping system abbreviation in 1/4" high letters and sequenced valve numbers 1/2" high and with 5/32" hole for fastener.
 - 1. Provide 1-1/2" diameter tags, except as otherwise indicated.
 - 2. Fill tag engraving with black enamel.
- B. Valve Tag Fasteners: Provide manufacturer's standard solid brass chain (wire link or beaded type), or solid brass S-hooks of the sizes required for proper attachment of tags to valves, and manufactured specifically for that purpose.
- C. Access panel markers: Provide manufacturer's standard solid brass chain (wire link or beaded type), or solid brass S-hooks of the sizes required for proper attachment of tags to valves, and manufactured specifically for that purpose.
- D. Access Panel Markers: Provide manufacturer's standard 1/16" thick engraved plastic laminate access panel markers, with abbreviations and numbers corresponding to concealed valve. Include 1/8" center hole to allow attachment.

2.07 DIAGRAM AND SCHEDULE FRAMES

- A. General: For each page of schedule and/or diagrams, provide glazed display frame, with screws for removable mounting on masonry walls. Provide frames of finished hardwood or extruded aluminum, with SSB-grade sheet glass.

2.08 ENGRAVED PLASTIC-LAMINATE SIGNS

- A. General: Provide engraving stock melamine plastic laminate, complying with FS L-P-387, in the sizes and thicknesses indicated, engraved with engraver's standard letter style of the sizes and wording indicated, white with black core (letter color) except as otherwise indicated, punched for mechanical fastening except where adhesive mounting is necessary because of substrate.
- B. Thickness: 1/16" for units up to 20 sq. in. or 8" length; 1/8" for larger units.
- C. Fasteners: Self-tapping stainless steel screws, except contact-type permanent adhesive where screws cannot or should not penetrate the substrate in locations approved by the District Representative.

2.09 LETTERING AND GRAPHICS

- A. General: Coordinate names, abbreviations and other designations used in mechanical identification work, with corresponding designations shown, specified or scheduled. Provide numbers, lettering and wording as indicated, as recommended by manufacturers or as required for proper identification and operation/maintenance of mechanical systems and equipment.
 - 1. Multiple Systems: Where multiple systems of same generic name are shown and specified, provide identification which indicates individual system number as well as service (as examples; Boiler No.3, Air Supply No. 1H, Standpipe F12).

2.10 EQUIPMENT MARKERS

- A. Equipment Nameplates: Metal, with data engraved or stamped, for permanent attachment on equipment.

1. Data:
 - a. Manufacturer, product name, model number, and serial number.
 - b. Capacity, operating and power characteristics, and essential data.
 - c. Labels of tested compliances.
 2. Location: Accessible and visible.
 3. Fasteners: As required to mount on equipment.
- B. Equipment Markers: Engraved, color-coded laminated plastic. Include contact-type, permanent adhesive.
1. Terminology: Match schedules as closely as possible.
 2. Data.
 3. Name and plan number.
 - a. Equipment service.
 - b. Design capacity.
 - c. Other design parameters such as pressure drop, entering and leaving conditions, and speed.
 4. Size: 2 1/2 by 4 inches for control devices, dampers, and valves; 4-1/2 by 6 inches for equipment.
- C. Equipment Signs: ASTM D 709, Type I, cellulose, paper-base, phenolic resin-laminate engraving stock; Grade ES-2, black surface, black phenolic core, with white melamine sub-core, unless otherwise indicated. Fabricate in sizes required for message. Provide holes for mechanical fastening.
1. Data: Instructions for operation of equipment and for safety procedures.
 2. Engraving: Manufacturer's standard letter style, of sizes and with terms to match equipment identification.
 3. Retain and edit subparagraph above or first subparagraph below.
 4. Thickness: 1/16 inch for units up to 20 sq. in. or 8 inches in length, and 1/8 inch for larger units.
 5. Fasteners: Self-tapping, stainless-steel screws or contact-type, permanent adhesive.
- D. Access Panel and Door Markers: 1/16-inch thick, engraved laminated plastic, with abbreviated terms and numbers corresponding to identification. Provide 1/8-inch center hole for attachment.
1. Fasteners: Self-tapping, stainless-steel screws or contact-type, permanent adhesive.

2.11 PLASTIC DUCT MARKERS

- A. Engraved, color-coded laminated plastic. Include direction and quantity of airflow and duct service (such as supply, return, and exhaust). Include contact-type, permanent adhesive.

PART 3 EXECUTION

3.01 GENERAL INSTALLATION REQUIREMENTS

- A. Coordination: Where identification is to be applied to surfaces which require insulation, painting or other covering or finishes, including valve tags in finished mechanical spaces, install identification after completion of covering and painting. Install identification prior to installation of acoustical ceilings and similar removable concealment.

3.02 PIPING SYSTEM IDENTIFICATION

- A. General: Install pipe markers of one of the following types on each system indicated to receive identification, and include arrows to show normal direction of flow:
 1. Plastic pipe markers, with application system as indicated under "Materials" in this section. Install on pipe insulation segment where required for hot-non-insulated pipes.
- B. Locate pipe markers as follows wherever piping is exposed to view in occupied spaces, machine rooms, accessible maintenance spaces (shafts, tunnels, plenums) and exterior non-concealed locations.

1. Near each valve and control device.
2. Near each branch, excluding short take-offs for fixtures and terminal units; mark each pipe at branch, where there could be question of flow pattern.
3. Near locations where pipes pass through walls, floors ceilings, or enter non-accessible enclosures.
4. At access doors, manholes similar access points which permit view of concealed piping.
5. Near major equipment items and other points of origination and termination.
6. Spaced intermediately at maximum spacing of 50' along each piping run, except reduce spacing to 25' in congested areas of piping and equipment.
7. On piping above removable acoustical ceilings, except omit intermediately spaced markers.

3.03 UNDERGROUND PIPING IDENTIFICATION

- A. General: During back-filling/top-soiling of each exterior underground piping systems, except sanitary sewer and storm drainage install continuous underground-type plastic line marker, located directly over buried line at 6" to 8" below finished grade. Where multiple small lines are buried in common trench and do not exceed overall width of 16", install single line marker.

3.04 VALVE IDENTIFICATION

- A. General: Provide valve tag on every valve, cock and control device in each piping system; exclude check valves, valves within factory-fabricated equipment units, plumbing fixture faucets, convenience and lawn-watering hose bibs, and shut-off valves at plumbing fixtures, HVAC terminal devices and similar rough-in connections of end-use fixtures and units. List each tagged valve on valve schedule for each piping system.
- B. Mount valve schedule frames and schedules in machine rooms where indicated or, if not otherwise indicated, where directed by Architect/Engineer.

3.05 MECHANICAL EQUIPMENT IDENTIFICATION

- A. General: Install engraved plastic laminate sign or plastic equipment marker on or near each major item of mechanical equipment and each operational device, as specified herein if not otherwise specified for each item or device. Mechanically affix signs or markers on equipment with non-corroding fasteners on four sides if square or rectangular, or three points if round. If affixing to equipment may damage the unit, then affixing to an adjacent permanent hard surface as approved by the District Representative is acceptable. Provide signs for the following general categories of equipment and operational devices:
 1. Fuel-burning units including boilers, furnaces, heaters.
 2. Pumps, compressors, chillers, condensers and similar motor-driven units.
 3. Fans and blowers.
 4. Packaged HVAC central-station or zone-type units.
 5. Split air conditioner indoor and outdoor units
 6. Single Duct terminal units and all equipment in ceiling space.

(In addition to the equipment tag, install an identification tag for VAV units in locations approved by architect to indicate where each unit is installed above the ceiling. Coordinate the Installation location, type, size and color of this tag with the architect.)
- B. Lettering Size: Minimum 1/4" high lettering for name of unit where viewing distance is less than 2'-0", 1/2" high for distances up to 6'-0", and proportionately larger lettering for greater distances. Provide secondary lettering of 2/3 to 3/4 of size of the principal lettering.
- C. Text of Signs: In addition to name of identified unit, provide lettering to distinguish between multiple units, inform operator of operational requirements, indicate safety and emergency precautions, and warn of hazards and improper operations.

3.06 ADJUSTING AND CLEANING

- A. Adjusting: Relocate any mechanical identification device which has become visually blocked by work of this division or other divisions.
- B. Cleaning: Clean face of identification devices, and glass frames of valve charts.

END OF SECTION

SECTION 22 07 00

PLUMBING INSULATION

PART 1 GENERAL

1.01 SECTION INCLUDES

- A. Extent of mechanical insulation required by this section is indicated on drawings and schedules, and by requirements of this section, and includes the following:
 - 1. Piping Systems Insulation:
 - a. Fiberglass.
 - b. Calcium Silicate.
 - c. Flexible Unicellular.
 - 2. Equipment Insulation:
 - a. Fiberglass
 - b. Calcium Silicate
 - c. Flexible Unicellular.
 - 3. Acoustical Insulation
 - a. Fiberglass

1.02 RELATED SECTIONS

- A. Refer to Division-22 section 22 05 29 for protection saddles, protection shields, and thermal hanger shields; not work of this section.
- B. Refer to Division-22 section 22 05 53 for installation of identification devices for piping, ductwork, and equipment; not work of this section.

1.03 SUBMITTALS

- A. Product Data: Submit manufacturer's technical product data and installation instructions for each type of mechanical insulation. Submit schedule showing manufacturer's product number, K-value, thickness, and furnished accessories for each mechanical system requiring insulation.
- B. Maintenance Data: Submit maintenance data and replacement material lists for each type of mechanical insulation. Include this data and product data in maintenance manual.

1.04 QUALITY ASSURANCE

- A. Flame/Smoke Ratings: Provide composite mechanical insulation (insulation, jackets, coverings, sealers, mastics and adhesives) with flame-spread index of 25 or less, and smoke-developed index of 50 or less, as tested by ASTM E 84 (NFPA 255) method.
- B. As a minimum, insulation shall meet installed thermo (R) value as set forth in Title 24 California Code of Regulations (CCR) Part 6 Section 123, 124; and Part 4 Section 605.0, or as indicated in contract documents, whichever is greater.

1.05 DELIVERY, STORAGE, AND HANDLING

- A. Deliver insulation, coverings, cements, adhesives, and coatings to site in containers with manufacturer's stamp or label, affixed showing fire hazard indexes of products.
- B. Protect insulation against dirt, water, and chemical and mechanical damage. Do not install damaged or wet insulation; remove from project site.

PART 2 PRODUCTS

2.01 ACCEPTABLE MANUFACTURERS

- A. Manufacturer: Subject to compliance with requirements, provide products of one of the following:

1. Armstrong World Industries, Inc.
2. Babcock and Wilcox; Insulating Products Div.
3. Certainteed Corp.
4. Knauf Fiber Glass GmbH.
5. Manville Products Corp.
6. Owens-Corning Fiberglas Corp.
7. Pittsburgh Corning Corp.
8. Rubatex Corp.

2.02 PIPING INSULATION MATERIALS

- A. Fiberglass (Mineral Fiber) Piping Insulation: ASTM C547, Class 1 unless otherwise indicated. Manville Products Corp. Micro-Lok, Owens-Corning Fiberglas Corp., ASJ/SL-11 or equivalent.
- B. Calcium Silicate Piping Insulation: ASTM C533, Type I. Owens-Corning Fiberglass Corp. "Kaylo Asbestos Free" or equivalent.
- C. Flexible Unicellular Piping Insulation: ASTM C534, Type I. Armstrong World Industries, Inc. or Rubatex Corp. meeting ASTM E-84 25/50 index.
- D. Jackets for Piping Insulation: ASTM C921, Type I (Vapor Barrier) for piping with temperatures below ambient. (Type II (Water Vapor Permeable) for piping with temperatures above ambient. Type I may be used for all piping at Installer's option.
 1. Encase pipe fittings insulation with one-piece pre-molded PVC fitting covers, fastened as per manufacturer's recommendations. Zeston PVC Insulated fitting covers or equivalent.
 2. Encase exterior piping insulation with aluminum jacket with weather-proof construction.
- E. Staples, Bands, Wires, and Cement: As recommended by insulation manufacturer for applications indicated.
- F. Adhesives, Sealers, and Protective Finishes: As recommended by insulation manufacturer for applications indicated.
- G. All Insulation shall be U.L. listed showing flame spread not greater than 25, nor smoke greater than 50, per NFPA 90A.

2.03 EQUIPMENT INSULATION MATERIALS

- A. Flexible Fiberglass Equipment Insulation: ASTM C553, Type II, Class F-1, Owens-Corning Fiberglass, Inc., Type 701 1.5 lbs/Ft3.
- B. Calcium Silicate Equipment Insulation: ASTM C533, Type I, Block; Owens/Corning Fiberglass, Inc., Kaylo Asbestos Free, U-Grooved block insulation.
- C. Jacketing Material for Equipment Insulation: Provide canvas jacketing material, not less than 7.8 ounces per square yard, or metal jacket at Installer's option, except as otherwise indicated.
- D. Equipment Insulation Compounds: Provide adhesives, cements, sealers, mastics and protective finishes as recommended by insulation manufacturer for applications indicated.
- E. Equipment Insulation Accessories: Provide staples, bands, wire, wire netting, tape corner angles, anchors and stud piping as recommended by insulation manufacturer for applications indicated.
- F. All Insulation shall be U.L. listed showing flame spread not greater than 25, nor smoke greater than 50, per NFPA 90A.

2.04 ACOUSTICAL INSULATION

- A. Rigid Fiberglass Insulation: ASTM C612, Class 1, Owens/Corning Fiberglass, Inc., 10 Lbs/ft3.

PART 3 EXECUTION

3.01 INSPECTION

- A. Examine areas and conditions under which mechanical insulation is to be installed. Do not proceed with work until unsatisfactory conditions have been corrected in manner acceptable to Installer.

3.02 PLUMBING PIPING SYSTEM INSULATION:

- A. Insulation Omitted: Omit insulation on chrome-plated exposed piping (except for handicapped fixtures), air chambers, unions, strainers, check valves, balance cocks, flow regulators, drain lines from water coolers, drainage piping located in crawl spaces or tunnels, buried piping, fire protection piping, and pre-insulated equipment.
- B. Cold Piping:
 - 1. Application requirements: Insulate the following cold plumbing piping systems:
 - a. Potable chilled water piping.
 - b. Plumbing drains carrying cold condensate.
 - 2. Insulate each piping system specified above with one of the following types and thicknesses of insulation:
 - a. Fiberglass: 1" thickness.
 - b. Flexible Unicellular: 1/2" thickness.
- C. Hot Piping:
 - 1. Application Requirements: Insulate the following hot plumbing piping systems.
 - a. Potable hot water piping.
 - b. Potable hot water re-circulating piping.
 - c. Hot drain piping (where indicated).
 - 2. Insulate each piping system specified above with one of the following types and thicknesses of insulation.
 - a. Fiberglass: 1" thick for pipe sizes up to and including 6", 1-112" thick for pipe sizes over 6".

3.03 EQUIPMENT INSULATION

- A. Cold Equipment (Below Ambient Temperature):
 - 1. Application requirements: Insulate the following cold equipment:
 - a. Refrigeration equipment, including chillers, tanks and pumps.
 - b. Drip pans under chilled equipment.
 - c. Cold and chilled water pumps.
 - d. Pneumatic water tanks:
 - 2. Insulate each item of equipment specified above with one of the following types and thicknesses of insulation:
 - a. Fiberglass: 2" thick for cold surfaces above 35°F and 3" thick for surfaces 35°F and lower.
- B. Hot Equipment (Above Ambient Temperature):
 - 1. Application Requirements: Insulate the following hot equipment:
 - a. Boilers (not pre-insulated at factory).
 - b. Water heaters.
 - c. Hot water expansion tanks.
 - d. Hot water pumps.
 - 2. Insulate each item of equipment specified above with one of the following types and thicknesses of insulation.
 - a. Fiberglass: 2" thick, except 3" thick for low-pressure boilers and steam-jacketed heat exchangers.
- C. Breaching and Stacks:

1. Application Requirements: Insulate the following breechings and stacks:
 - a. Breechings between heating equipment outlet and stack or chimney connection, except for double wall or factory insulated breechings.

3.04 INSTALLATION OF PIPING INSULATION

- A. General: Install insulation products in accordance with manufacturer's written instructions, and in accordance with recognized industry practices to ensure that insulation serves its intended purpose.
- B. Install insulation on pipe systems subsequent to installation of heat tracing, painting, testing, and acceptance of tests.
- C. Install insulation materials with smooth and even surfaces. Insulate each continuous run of piping with full-length units of insulation, with a single cut piece to complete run. Do not use cut pieces or scraps abutting each other.
- D. Clean and dry pipe surfaces prior to insulating. Butt insulation joints firmly together to ensure a complete and tight fit over surfaces to be covered.
- E. Maintain integrity of vapor barrier jackets on pipe insulation, and protect to prevent puncture or other damage.
- F. Cover valves, fittings and similar items in each piping system with equivalent thickness and composition of insulation as applied to adjoining pipe run. Install factory molded, precut or job fabricated units (at Installer's option) except where specific form or type is indicated.
- G. Extend piping insulation without interruption through walls, floors and similar piping penetrations, except where otherwise indicated.
- H. Butt pipe insulation against pipe hanger insulation inserts. For hot pipes, apply 3" wide vapor barrier tape or band over the butt joints. For cold piping apply wet coat of vapor barrier lap cement on butt joints and seal joints with 3" wide vapor barrier tape or band.

3.05 INSTALLATION OF EQUIPMENT INSULATION

- A. General: Install equipment thermal insulation products in accordance with manufacturer's written instructions, and in compliance with recognized industry practices to ensure that insulation serves intended purpose.
- B. Install insulation materials with smooth and even surfaces and on clean and dry surfaces. Redo poorly fitted joints. Do not use mastic or joint sealer as filler for gaping joints and excessive voids resulting from poor workmanship.
- C. Maintain integrity of vapor-barrier on equipment insulation and protect it to prevent puncture and other damage.
- D. Do not apply insulation to equipment, breechings, or stacks while hot.
- E. Apply insulation using the staggered joint method for both single and double layer construction, where feasible. Apply each layer of insulation separately.
- F. Coat insulated surfaces with layer of insulating cement, trowel in workmanlike manner, leaving a smooth continuous surface. Fill in scored block, seams, chipped edges and depressions, and cover over wire netting and joints with cement of sufficient thickness to remove surface irregularities.
- G. Cover insulated surfaces with all-service jacketing neatly fitted and firmly secured. Lap seams at least 2". Apply over vapor barrier where applicable.

- H. Do not insulate hot water storage tank manholes, hand-holes, cleanouts, ASME stamp, and manufacturer's nameplate. Provide neatly beveled edge at interruptions of insulation.
- I. Provide removable insulation sections to cover parts of equipment which must be opened periodically for maintenance; include metal vessel covers, fasteners, flanges, frames and accessories.
- J. Equipment exposed to Weather: Protect outdoor insulation from weather by installation of weather-barrier mastic protective finish, or jacketing, as recommended by the manufacturer.

3.06 ACOUSTICAL INSTALLATION

- A. Install within confines of roof curbs for roof mounted air handlers and air conditioning units, and elsewhere as indicated on drawings
- B. Cut to fit snugly within curb and around duct at duct penetrations, 4" minimum thickness.

3.07 PROTECTION AND REPLACEMENT

- A. Replace damaged insulation which cannot be repaired satisfactorily, including units with vapor barrier damage and moisture saturated units.
- B. Protection: Insulation Installer shall advise Contractor of required protection for insulation work during remainder of construction period, to avoid damage and deterioration.

END OF SECTION

SECTION 22 10 00

PLUMBING PIPING

PART 1 GENERAL

1.01 RELATED SECTIONS

- A. The following sections contain requirements that relate to this section:
 - 1. Division 22 Section 22 05 00 applies to the work of this Section.
 - 2. Piping materials and installation methods peculiar to individual systems are specified within their respective system specification sections of Division 02 and 22.
 - 3. Valves are specified in a separate section and in individual piping system sections of Division 22.
 - 4. Expansion Compensation is specified within the respective system specification section of Division 22.
 - 5. Division 22 05 29 "Hangers and supports".
 - 6. Division 22 05 53 "Plumbing Identification".

1.02 SECTION INCLUDES

- A. This Section specifies piping materials and installation methods common to more than one section of Division 22 and includes joining materials, fire stop sealants, and basic piping installation instructions.

1.03 SUBMITTALS

- A. Refer to Division 01 and Section 22 05 00 for administrative and procedural requirements for submittals.
- B. Product Data: Submit product data on fire stop sealants.

1.04 QUALITY ASSURANCE

- A. Welding procedures and testing shall comply with ANSI Standard B31.1.0- Standard Code for Pressure Piping, Power Piping, and The American Welding Society, Welding Handbook.
- B. Soldering and brazing procedures shall conform to ANSI 89.1 Standard Safety Code for Mechanical Refrigeration.

1.05 DELIVERY, STORAGE, AND HANDLING

- A. Provide factory-applied plastic end-caps on each length of pipe and tube, except for concrete, corrugated metal, hub-and-spigot, and clay pipe. Maintain end-caps through shipping, storage and handling to prevent pipe-end damage and prevent entrance of dirt, debris, and moisture.
- B. Protect stored pipes and tubes. Elevate above grade and enclose with durable, waterproof wrapping. When stored inside, do not exceed structural capacity of the floor.
- C. Protect flanges, fittings, and specialties from moisture and dirt by inside storage and enclosure, or by packaging with durable, waterproof wrapping.

PART 2 PRODUCTS

2.01 PIPE AND FITTINGS

- A. Refer to the individual piping system specification sections in Division 22 for specifications on piping and fittings relative to that particular system.
- B. Weld-0-Lets: Welding Weld-0-Lets may be used in lieu of tees where branch connection pipe size is two or more pipe sizes smaller than main header size.

2.02 JOINING MATERIALS

- A. Welding Materials: Comply with Section II, Part C, ASME Boiler and Pressure Vessel Code for welding materials appropriate for the wall thickness and chemical analysis of the pipe being welded.
- B. Brazing Materials: Comply with SFA-5.8, Section II, ASME Boiler and Pressure Vessel Code for brazing filler metal materials appropriate for the materials being joined.
- C. Soldering Materials: Refer to individual piping system specifications for solder appropriate for each respective system.
- D. Soldering materials shall not contain lead.
- E. Gaskets for Flanged Joints: Gasket material shall be full-faced for cast-iron flanges and raised-face for steel flanges. Select materials to suit the service of the piping system in which installed and which conform to their respective ANSI Standard (A21.11, B16.20, or B16.21). Provide materials that will not be detrimentally affected by the chemical and thermal conditions of the fluid being carried.
- F. All pipe shall be reamed to the full I.D. of the pipe/tube and remove all burrs before joining.

2.03 SLEEVES AND SEALS

- A. Sleeves:
 1. Sheet-Metal Sleeves: 5" and Smaller, 20 gage galvanized sheet metal; 6" and Larger, 10 gage, galvanized sheet metal, round tube closed with welded longitudinal joint.
 2. Steel Sleeves: Schedule 40 galvanized, welded steel pipe, ASTM A53, Grade A.
 3. Galvanized steel telescoping type: Galvanized sheet metal per manufacturer's standards.
 4. Polyethylene Sleeves: Manufacturer's standard product.
- B. Mechanical Sleeve Seals: Modular mechanical type, consisting of interlocking synthetic rubber links shaped to continuously fill annular space between pipe and sleeve, connected with bolts and pressure plates which cause rubber sealing elements to expand when tightened, providing watertight seal and electrical insulation.

2.04 FIRESTOP SEALANT

- A. Fire stopping material shall be asbestos-free and capable of maintaining an effective barrier against flame and gases in compliance with the following requirements:
 1. Flame Spread: 25 or less, ASTM E 84.
 2. Smoke Development: 50 or less, ASTM E 84.
 3. Combustibility: Noncombustible; ASTM E 136.
- B. Material when installed shall have the same fire rating as the assembly in which it is being installed.

2.05 PIPING ISOLATION

- A. Manufacturer's standard product for providing sound and electrolysis isolation.

PART 3 EXECUTION

3.01 PREPARATION

- A. Ream ends of pipes and tubes, and remove all burrs, to full I.D. of the pipe/tube. Bevel plain ends of steel pipe.
- B. Remove scale, slag, dirt, and debris from both inside and outside of piping and fittings before assembly.

3.02 INSTALLATIONS

- A. General Locations and Arrangements: Drawings (plans, schematics, and diagrams) indicate the general location and arrangement of the piping systems. Location and arrangement of piping layout take into consideration pipe sizing and friction loss, expansion, pump sizing, and other

design considerations. So far as practical, install piping as indicated. Refer to individual system specifications for requirements for coordination drawing submittals.

- B. Conceal all pipe installations in walls, pipe chases, utility spaces, above ceilings, below grade or floors, unless indicated otherwise.
- C. Install piping free of sags or bends and with ample space between piping to permit proper insulation applications.
- D. Install exposed piping at right angles or parallel to building walls. Diagonal runs are not permitted, unless expressly indicated on the Drawings.
- E. Install piping tight to slabs, beams, joists, columns, walls and other permanent elements of the building. Provide space to permit insulation applications, with 1" clearance outside the insulation. Allow sufficient space above removable ceiling panels to allow for panel removal.
- F. Locate groups of pipes parallel to each other, spaced to permit applying full insulation and servicing of valves.
- G. Install drains at low points in mains, risers, and branch lines consisting of a tee fitting, 3/4" ball valve, and short 3/4" threaded nipple and cap.
- H. Exterior Wall Penetrations: Seal pipe penetrations through exterior walls using sleeves and mechanical sleeve seals.
- I. Coordinate to provide curb, minimum 4" above finish floor, for all pipe shafts or floor openings for multiple pipes.
- J. Fire Barrier Penetrations: Where pipes pass through fire rated walls, partitions, ceilings, or floors, the fire rated integrity shall be maintained.

3.03 PIPE SUPPORTS AND HANGERS

- A. Horizontal Pipes: Hangers and supports shall be hung from solid rods, and lengths of which shall be adjustable. Strap hangers will not be permitted. In lieu of individual hangers, trapeze hangers may be used for parallel pipes, details of which shall be submitted to the Architect for approval. Hanger rods for both single and trapeze hangers shall be hung from suitable clips, beam clamps or inserts, as necessary. For concrete construction, inserts shall be set in forms before concrete is poured. Explosive type fasteners or studs will not be permitted. "Phillips" type shield may be used when authorized by the Architect. No piping shall be supported by any wire, rope, wood or other makeshift device.
- B. Provide hangers size and spacing per SMACNA "Guidelines for Seismic Restraint of Mechanical Systems".
- C. Where building construction does not permit the above-specified spacing of hangers, the Contractor shall provide adequate additional steel supports. Location and details shall be submitted to the Architect for approval. In all cases, pipe supports shall be spaced to provide adequate support for the pipes, the medium in the pipes, insulation, valves and fittings.
- D. All vertical pipelines shall be supported, not hung, at each floor. Malleable iron or steel pipe clamps of ample size, bolted around the pipes, shall be used for these pipe supports. All vertical water piping shall have vibration isolators between support clamp and structure.
- E. Pipe hangers shall be of the positive restraint type or be provided with approved restraint clips to prevent lateral movement of attachment.
- F. Pipe hangers shall be of the positive restraint type or be provided with approved restraint clips to prevent lateral movement of attachment.
- G. Contractor may refer to details applicable in the SMACNA "Guidelines for Seismic Restraint of Mechanical Systems".

3.04 FITTINGS AND SPECIALTIES

- A. Use fittings for all changes in direction and all branch connections.
- B. Remake leaking joints using new materials.
- C. Install Y-type strainers with blow-down valves on the supply side of each control valve, pressure reducing or regulating valve, solenoid valve, and elsewhere as indicated.
- D. Install unions adjacent to each valve and at the final connection to each piece of equipment and plumbing fixture having 2" and smaller connections, and elsewhere as indicated.
- E. Install Flanges in piping 2-1/2" and larger, where indicated, adjacent to each valve, and at the final connection to each piece of equipment.
- F. Install dielectric unions to connect piping materials of dissimilar metals in dry piping systems (gas, compressed air).
- G. Install dielectric fittings to connect piping materials of dissimilar metals in wet piping systems (water, steam).

3.05 JOINTS

- A. Steel Pipe Joints:
 - 1. Pipe 2" and Smaller: Thread pipe with tapered pipe threads in accordance with ANSI B2.1. Cut threads full and clean using sharp dies. Ream threaded ends to remove burrs and restore full inside diameter. Apply pipe joint lubricant or sealant suitable for the service for which the pipe is intended on the male threads at each joint and tighten to leave not more than 3 threads exposed.
 - 2. Pipe Larger than 2":
 - a. Weld pipe joints (except for exterior water service pipe) in accordance with ASME Code for Pressure Piping, B31.
 - b. Weld pipe joints of exterior water service pipe in accordance with AWWA C206.
 - c. Install flanges on all valves, apparatus, and equipment. Weld pipe flanges to pipe ends in accordance with ASME B31.1.0 Code for Pressure Piping. Clean flange faces and install gaskets. Tighten bolts to torque specified by manufacturer of flange and flange bolts, to provide uniform compression of gaskets.
- B. Non-ferrous Pipe Joints:
 - 1. Brazed and Soldered Joints: For copper tube and fitting joints, braze joints in accordance with ANSI B31.1.0 -Standard Code for Pressure Piping, Power Piping and ANSI B9.1 - Standard Safety Code for Mechanical Refrigeration.
 - 2. Thoroughly clean tube surface and inside surface of the cup of the fittings, using every fine emery cloth, prior to making soldered or brazed joints. Wipe tube and fittings clean and apply flux. Flux shall not be used as the sole means for cleaning tube and fitting surfaces.
 - 3. Mechanical Joints: Flared compression fittings may be used for refrigerant lines 3/4" and smaller.
- C. Joints for other piping materials are specified within the respective piping systems sections.

3.06 INSTALLATION OF SLEEVES

- A. Provide pipe sleeves for pipes to pass through walls, floor and roofs. Diameter of sleeve to be 1-inch larger than the outside diameter of pipe or pipe and covering of insulated pipe. Galvanized steel telescoping type sleeves or polyethylene may be used. Where seepage may occur, use steel pipe sleeves.
- B. All pipe sleeves through floors other than floors on grade shall extend 2-inches above finished floor and shall be caulked with mineral wool. Provide collar where polyethylene sleeve is used.

- C. Where required in existing construction, or where sleeves have been omitted, openings for pipe may be core drilled in floors and/or walls or partitions, providing prior acceptance of such core drilling is obtained from the Architect. Holes core drilled through floors above grade shall be provided with sleeves extending 2-inches above finish floor as hereinbefore specified.
- D. Seal with resilient sealant: Dow Corning "Fire Stop" or approved equal.

3.07 INSTALLATION OF FIRE STOP SEALANT

- A. Fire-stopping shall be provided at, but not limited to, duct, and piping penetrations through floor slabs and through time rated partitions or firewalls.
- B. Install fire-stopping materials in accordance with the manufacturer's instructions and the following requirements.
- C. Filling: Fire-stopping materials shall completely fill the void spaces.
- D. Coordination: Coordinate the work with other trades. Fire-stopping materials at penetrations of insulated pipes and ducts shall be applied prior to insulation, unless the insulation meets the requirements specified for fire-stopping.
- E. Surface Preparation: Surfaces to be in contact with fire-stopping materials shall be free of dirt, grease, oil, loose material, rust, or other substances that may affect proper fitting or the required fire resistance.

3.08 INSTALLATION OF PIPE ISOLATION

- A. Provide sound and electrolysis isolation on all un-insulated, pipes, Semco "Trisolators" or Potter-Roamer "Prisolators".

3.09 INSTALLATION OF PIPE FLASHING

- A. Pipe flashing assemblies, "Semco" Fig. 1100-4, as required, seal the joint between flashing and pipe with waterproofing compound. Install counter-flashing sleeve to cover a minimum of 3/4-inch to top of lead flashing, making the top joint permanently watertight.

3.10 TESTING OF PIPING

- A. Provide notification of test at least three working days prior to tests on all or part of any piping system. Do not allow or cause any piping system to be insulated, covered, concealed or enclosed until such systems have been tested and reviewed.
- B. Provide all necessary materials (including temporary isolation valves or caps), pumps, testing media and labor for testing. Temporarily remove any device in piping system, which will not withstand test pressure specified, and reinstall same after successful testing. Test time begins to accrue after full test pressure is achieved.
- C. Testing and inspection of all piping systems and associated equipment for leaks shall be accomplished after installation and cleaning and prior to placing into service. Flanges, threaded joints and all welds shall be left unpainted and un-insulated until the piping systems have been approved.
- D. A rigid visual inspection of each specific piping system shall be made prior to conducting tightness tests, to ascertain that all appurtenances and equipment are provided, properly connected and supported, and in all respects ready for testing.
- E. Equipment such as pumps, chillers, tanks, heat exchangers, flexible hose, safety valves and similar equipment shall not be subjected to the piping system test pressure. Equipment shall either be disconnected from the piping or be isolated by valves or blanks during testing and reinstalled after acceptance by the Owner.

- F. Indicating pressure gauges mounted locally may be tested with the lines provided the test pressure does not exceed the scale range.
- G. Orifice plates, rotometers, displacement meters and other line inserts shall either not be installed until completion of all testing, or shall be removed prior to any tests and reinstalled after test has been accepted by the Owner.
- H. The application of pressure to a system shall be under control at all times, so that in no case shall the test pressure be exceeded by more than 6 percent.
- I. Gauges used for testing shall be tested for accuracy as directed or approved by the Owner, and then installed as close as possible to the low point of the piping system.
- J. Do not apply test pressure until the piping system and its contents approach the same temperature.
- K. While piping is under test, exercise care, that excessive pressure does not occur due to increase in ambient temperature.
- L. Control Valves:
 - 1. Control valves which are installed with block and by-pass valve shall have the block valve closed, the by-pass valve opened, and a temporary pipe piece inserted in place of the control valve (or a test blank may be installed on each side of the control valve) until all flushing and testing of all lines of that system is completed and accepted by the Owner, after which they shall be reinstalled.
 - 2. Control valves installed without 'block or by-pass valves shall be replaced by a pipe piece during flushing and testing of the system. After acceptance of the flushing they shall be reinstalled.
- M. Minimum piping test pressures shall be as noted in tabulation; or they shall be 150 percent of design pressure for the specific system being tested, whichever is higher.

SYSTEM	TEST MEDIUM	TESTING PRESSURE (PSIG)	DURATION (HOURS)	ACCEPTABLE TOLERANCE
Soil, Water, Vent, & Storm Water	Water	Top of highest vent	4	No joint sweat
Water	Water	150	4	None. Except temperature change.
Fuel Gas	Air	60	4	None. Except temperature change.
Fire Sprinkler	Water	200	4	None. Except temperature change.

- N. Conduct hydrostatic tests with water at a temperature below 100 degrees F.
 - 1. Fill the system slowly with water and vent at highest points to expel the air before pressurizing.
 - 2. Carefully examine all joints for leaks or defects.
 - 3. Provide connections as required to accomplish the above.
- O. Keep accurate test records of each line or system tested and provide copies of same to Owner after acceptance. Each test shall include:

1. Identification of piping system and test number.
2. Testing medium.
3. Test pressure.
4. Date of test acceptance.

3.11 ADJUSTMENTS

- A. At the completion of the Work, completely adjust all valves and equipment for their proper use and rating.

END OF SECTION

SECTION 22 10 19

PLUMBING PIPING SPECIALTIES

PART 1 GENERAL

1.01 RELATED SECTIONS

- A. This section applies to all piping systems specified in Division 22.
- B. Valves are specified in a separate section and in individual piping system sections of Division 22.
- C. Fire Barrier Penetration Seals are specified in Section 22 10 00.

1.02 SECTION INCLUDES

- A. This Section specifies piping specialties and installation methods common to more than one section of Division 22.

1.03 SUBMITTALS

- A. Refer to Division 01 and Basic Mechanical Requirements for administrative and procedural requirements for submittals.
- B. Product Data: Submit product data on the following items:
 - 1. Escutcheons
 - 2. Dielectric Unions and Fittings
 - 3. Mechanical Sleeve Seals
 - 4. Strainers

1.04 DELIVERY, STORAGE, AND HANDLING

- A. Protect flanges, fittings, and specialties from moisture and dirt by inside storage and enclosure, or, by packaging with durable, waterproof wrapping.

PART 2 PRODUCTS

2.01 MANUFACTURERS

- A. Manufacturer Uniformity: Conform to the requirements specified in Basic Mechanical Requirements, under "Product Options."
- B. Manufacturer: Subject to compliance with requirements, provide piping materials and specialties from one of the following:
 - 1. Pipe Escutcheons:
 - a. Chicago Specialty Mfg. Co.
 - b. Grinnell
 - c. Seaton-Cadwell
 - 2. Dielectric Waterway Fittings:
 - a. EpcO Sales, Inc.
 - b. Victaulic Company of America
 - 3. Dielectric Unions:
 - a. Eclipse, Inc.
 - b. Perfection Corp.
 - c. Watts Regulator Co.
 - 4. Strainers:
 - a. Armstrong Machine Works
 - b. Hoffman Specialty ITT; Fluid Handling Div.
 - c. Metraflex Co.
 - d. R-P&C Valve; Div. White Consolidated Industries, Inc.
 - e. Spirax Sarco

- f. Trane Co.
 - g. Victaulic Co. of America. (Low pressure applications only).
 - h. Watts Regulator Co.
5. Mechanical Sleeve Seals:
- a. Thunderline Corp.

2.02 PIPE AND FITTINGS

- A. Refer to the individual piping system specification sections in Division 22 for specifications on piping and fittings relative to that particular system.

2.03 JOINING MATERIALS

- A. Welding Materials: Comply with Section II, Part C, ASME Boiler and Pressure Vessel Code for welding materials appropriate for the wall thickness and chemical analysis of the pipe being welded.
- B. Brazing Materials: Comply with SFA-5.8, Section II, ASME Boiler and Pressure Vessel Code for brazing filler metal materials appropriate for the materials being joined.
- C. Soldering Materials: Refer to individual piping system specifications for solder appropriate for each respective system.
- D. Gaskets for Flanged Joints: Gasket material shall be full-faced for cast-iron flanges and raised-face for steel flanges. Select materials to suit the service of the piping system in which installed and which conform to their respective ANSI Standard (A21.11, B16.20, or B16.21). Provide materials that will not be detrimentally affected by the chemical and thermal conditions of the fluid being carried.

2.04 PIPING SPECIALTIES

- A. Escutcheons: Chrome-plated, stamped steel, hinged, split-ring escutcheon, with set screw. Inside diameter shall closely fit pipe outside diameter, or outside of pipe insulation where pipe is insulated. Outside diameter shall completely cover the opening in floors, walls, or ceilings.
- B. Unions: Malleable-iron, Class 150 for low pressure service and class 250 for high pressure service; hexagonal stock, with ball-and-socket joints, metal-to-metal bronze seating surfaces; female threaded ends.
- C. Dielectric Unions: Provide dielectric unions with appropriate end connections for the pipe materials in which installed (screwed, soldered, or flanged), which effectively isolate dissimilar metals, prevent galvanic action, and stop corrosion.
- D. Dielectric Waterway Fittings: Electroplated steel or brass nipple, with an inert and non-corrosive, thermoplastic lining.
- E. Y-Type Strainers: Provide strainers full line size of connecting piping, with ends matching piping system materials. Screens shall be Type 304 stainless steel, with 3/64" perforations at 233 per square inch.
 - 1. Provide strainers with 125 psi working pressure rating for low-pressure applications, and 250 psi pressure rating for high-pressure application.
 - 2. Threaded Ends, 2" and Smaller: Cast-iron body, screwed screen retainer with centered blow-down fitted with pipe plug.
 - 3. Threaded Ends, 2-1/2" and Larger: Cast-iron body, bolted screen retainer with off-center blow-down fitted with pipe plug.
 - 4. Flanged Ends, 2-1/2" and Larger: Cast-iron body, bolted screen retainer with off-center blow-down fitted with pipe plug.
 - 5. Butt Welded Ends, 2-1/2" and Larger for Low Pressure Application: Schedule 40 cast carbon steel body, bolted screen retainer with off-center blow-down fitted with pipe plug.

6. Butt Welded Ends, 2-1/2" and Larger for High Pressure Application: Schedule 80 cast carbon steel body, bolted screen retainer with off-center blow-down fitted with pipe plug.
 7. Grooved Ends, 2-1/2" and Larger: Tee pattern, ductile-iron or malleable-iron body and access end cap, access coupling with EDPM gasket.
- F. Mechanical Sleeve Seals: Modular mechanical type, consisting of interlocking synthetic rubber links shaped to continuously fill annular space between pipe and sleeve, connected with bolts and pressure plates which cause rubber sealing elements to expand when tightened, providing watertight seal and electrical insulation.

PART 3 EXECUTION

3.01 ESCUTCHEONS

- A. Install escutcheons at all exposed penetrations of piping through walls, ceilings, and floors in rooms with finish surfaces.

3.02 FITTINGS AND SPECIALTIES

- A. Install strainers on the supply side of each control valve, pressure reducing or regulating valve, solenoid valve, and elsewhere as indicated.
- B. Install unions adjacent to each valve and at the final connection to each piece of equipment and plumbing fixture having 2" and smaller connections, and elsewhere as indicated.
- C. Install Flanges in piping 2-1/2" and larger, where indicated, adjacent to each valve, and at the final connection to each piece of equipment.
- D. Install dielectric unions to connect piping materials of dissimilar metals in dry piping systems (gas, compressed air, vacuum).
- E. Install dielectric fittings to connect piping materials of dissimilar metals in wet piping systems (water, steam).

END OF SECTION

SECTION 26 05 00
COMMON WORK RESULTS FOR ELECTRICAL

NOTE TO ARCHITECT/PROJECT MANAGER: 1.21 Need Values for each project

PART 1 - GENERAL

1.01 SCOPE

- A. Work Included: All labor, materials, appliances, tools, equipment, facilities, transportation and services necessary for and incidental to performing all operations in connection with furnishing, delivery and installation of the work of this Section, complete, as shown on the drawings and/or specified herein. Work includes, but is not necessarily limited to, the following:
 - 1. Examine all other sections for work related to those other sections and required to be included as work under this section.
 - 2. Electrical General Provisions and requirements for electrical work.
 - 3. Division-1; General Requirements; General Conditions.
- B. Organization of the specifications into divisions, sections and articles, and arrangement of drawings shall not control the CONTRACTOR in dividing the contract work among subcontractors or in establishing the extent of work to be performed by any trade.

1.02 GENERAL SUMMARY OF ELECTRICAL WORK

- A. The specifications and drawings are intended to cover a complete installation of systems. The omission of expressed reference to any item of labor or material for the proper execution of the work in accordance with present practice of the trade shall not relieve the CONTRACTOR from providing such additional labor and materials.
- B. Refer to the drawings and shop drawings of other trades for additional details, which affect the proper installation of this work. Diagrams and symbols showing electrical connections are diagrammatic only. Wiring diagrams do not necessarily show the exact physical arrangement of the equipment.
- C. Before submitting a bid, the CONTRACTOR shall become familiar with all features of the building drawings and site drawings, which may affect the execution of the work. No extra payment will be allowed for failure to obtain this information.
- D. If there are omissions or conflicts between the drawings and specifications, clarify these points with the District's Representative before submitting bid and before commencing work.
- E. Provide work and material in conformance with the manufacturer's published recommendations for respective equipment and systems.

1.03 LOCATIONS OF EQUIPMENT

- A. The drawings indicate diagrammatically the desired locations or arrangements of conduit runs, outlets, equipment, etc., and are to be followed as closely as possible. Proper judgment must be exercised in executing the work so as to secure the best possible installation in the available space and to overcome local difficulties due to space limitations or interference of structure conditions encountered.
- B. Where outlets are placed on a wall, locate symmetrically with respect to each other, furniture, cabinets, and other features or finishes on the wall.
- C. In the event changes in the indicated locations or arrangements are necessary, due to developed conditions in the building construction or rearrangement of furnishings or equipment, such changes shall be made without cost to the contract, providing the change is ordered before the conduit runs, etc., and work directly connected to same is installed and no extra materials are required.

- D. Lighting fixtures in mechanical spaces are shown in their approximate location only. Do not install light outlets or fixtures until mechanical piping and ductwork is installed; then install lights in a location to provide best lighting.
- E. Coordinate and cooperate in every way with other trades in order to avoid interference and assure a satisfactory job.
- F. The location of the existing utilities, building, equipment and conduit shown on the drawings is approximate. Verify exact locations and routing of existing systems by potholing all trench routes prior to digging the trench. Pothole at least 100 feet ahead of the actual trenching to allow space to alter the new conduit routing to accommodate existing conditions.
- G. Underground Detection Services Existing Utility Structures
 1. Detection/location services shall be provided utilizing the latest detection equipment available. Services shall be performed by a company regularly engaged in the business of existing Underground Utility Structure Detection for the past five years.
 2. Prior to excavation and prior to directional boring the following work shall be performed:
 - a. Contractor to mark excavating and trenching/ directional boring locations and indicate width and depth.
 - b. Locate, by way of vertical and horizontal control dimensions, existing subgrade petroleum product pipes, process piping, conduits, sewer, water, gas, storm drain, electrical, telephone and irrigation lines in the affected areas of contract construction work.
 - c. Arrange and meet with the District's Representative to review existing underground conditions.
 - d. The proposed route of each excavation shall be continuously surveyed along the entire excavation path using ground-penetrating radar (GPR) operating from the surface grade. The GPR shall detect and map existing underground metal and non-metal, both private and public utility lines, pipes, conduits, conductors, etc. The GPR shall identify the horizontal and vertical location of existing underground conditions located at a depth of up to three (3) meters below finish grade and located with a vertical and horizontal accuracy within \pm 12-inches of actual condition. The Contractor shall add this information to the existing conditions site plan.
 3. Exercise extreme caution in directional boring, excavating and trenching on this site to avoid existing underground utilities and structures, and to prevent hazard to personnel and/or damage to existing underground utilities or structures. The contract documents, drawings and specifications do not include necessary components for construction safety, which is the responsibility of the CONTRACTOR.
 4. Repair/replace, without additional cost to the contract, and to the satisfaction of the District any existing work damaged that was identified in the record drawings provided; Identified by the District's Representative; Identified by the Underground Detection Services performed; or any existing work damaged as a result of failure to comply with all the referenced requirements.
 5. The CONTRACTOR shall contact Common Ground Alliance (CGA) telephone #811 "Know What's Below-Call Before You Dig" and Underground Service Alert (USA), not less than 72-hours prior to excavation. Contractor shall not excavate until verification has been received from CGA and USA that existing underground utilities serving the site have been located, identified, and marked.
- H. The locations of existing underground utilities, where shown on drawings, are shown diagrammatically and have not been independently verified by the District, the District's Representative, the Architect/Engineer. The District, the District's Representative, and the District's Architect/Engineer are not responsible for the location of underground utilities or structures, whether or not shown or detailed and installed under this or any other contracts. The CONTRACTOR shall identify each existing utility line prior to excavation and mark the locations on the ground of each existing utility line.

1.04 AIR CONDITIONING, HEATING, PLUMBING EQUIPMENT WIRING

Provide electrical work, materials, and control components required for proper operation of the air conditioning, heating and plumbing systems as indicated on the electrical, mechanical, and plumbing Contract Documents and specified herein.

1.05 POWER, TELEPHONE AND OTHER SIGNAL SERVICES

- A. Telephone, cable television, power, street lighting service and metering facilities shall conform to the requirements of the serving utility companies. CONTRACTOR shall verify service locations and requirements, and shall pay all costs levied by the serving utility companies for rendering utility services to the contract without additional cost to the DISTRICT. Service information will be furnished by the serving utilities. Comply with requirements of the DISTRICT'S telephone supplier.
- B. Conform to all requirements of the serving utility companies. Location of transformer pad and or manholes and pull boxes and routing of service conduits indicated on the drawings are approximate and shall be verified with the serving utility company prior to installation. Installation of service shall not begin until approved drawings have been received from the serving utility company.
- C. Within 30-calendar days of receipt of notice that the contract award has been made, the CONTRACTOR shall notify the New Business Departments of the District Office of the serving utility companies concerning the project contract and shall provide information as to the total lighting, power, telephone, and signal requirements of the contract. The CONTRACTOR shall furnish at the same time information as to the estimated completion date of job or the date when the respective utility company circuits, will be ready for installation, energizing and activation of the respective services.
- D. In addition to the requirements of the serving utility companies, all power, telephone and signal service conduits for utility company circuits, shall be completely encased in concrete on all sides, top and bottom. The concrete shall be red mix color and extend a minimum of three inches past the conduit.
- E. Contractor shall submit Electrical Utility metering and electrical service entrance equipment shop drawings to the Electric Utility Company supplying the project for review and approval by the serving Utility Company. The submittal and acceptance by the Utility shall occur prior to submitting of shop drawings to the DISTRICT'S Representative or A/E for review. Copies of the serving Electrical Utility approval of the equipment shall be included in the shop drawings submittals to the DISTRICT'S Representative and A/E.

1.06 PERMITS

Take out and pay for all required permits, inspections and examinations without additional cost to the DISTRICT.

1.07 QUALITY ASSURANCE

- A. Work and materials shall be in full accordance with the latest rules and regulations as follows. The following publications shall be included in the contract documents requirements. If a conflict occurs between the following publications and any other part of the contract documents, the requirements describing the more restrictive provisions shall become the applicable contract definition:
 - 1. California Code of Regulations Title 24.
 - 2. California Part 3 "California Electrical Code" CEC, Title 24 and Title 8 "Division of Industrial Safety".
 - 3. California Building Code - CBC.
 - 4. California Fire Code – CFC

5. The National Electrical Code – NEC/NFPA 70.
6. The Life Safety Code – NFPA 101.
7. The Uniform Building Code - UBC.
8. International Building Code – IBC.
9. National Fire Protection Agency-NFPA.
10. National Fire Alarm Code – NFAC/NFPA 72.
11. Underwriter’s Laboratory-UL.
12. Other applicable State and Local Government Agencies laws and regulations.
13. Electrical Installation Standards National Electrical Contractors Association (NECA) and National Electrical Installation Standards (NEIS):
 - a. NECA/NEIS-1: Standard of Practices for Good Workmanship in Electrical Contracting
 - b. NECA/NEIS-101: Standard for Installing Steel Conduit (Rigid, IMC, etc.)
 - c. NECA/NEIS-104: Recommended Practice for Installing Aluminum Building Wire and Cable
 - d. NECA/NEIS-105: Recommended Practice Installing Metal Cable Trays
 - e. NECA/NEIS-111: Recommended Practice Installing Nonmetallic Raceways
 - f. NECA/NEIS-230: Recommended Practice for Installing Motors
 - g. NECA/FOA-301: Standards for Installing and Testing Fiber Optic Cables
 - h. NECA/NEIS-305: Standard for Fire Alarm System Job Practice
 - i. NECA/NEIS-331: Standards for Installing Building and Service Entrance Grounding
 - j. NECA/NEIS-400: Recommended Practice for Installing and Maintaining Switchboards k. NECA/NEIS-402: Recommended Practice for Installing and Maintaining Motor Control Centers
 - l. NEIS/NECA and EGSA-404: Recommended Practice for installing Generator Sets
 - m. NECA/NEIS-405: Recommended Practices for installing and Commissioning Interconnected Generation Systems
 - n. NECA/NEIS-407: Recommended Practice for Installing Panelboards
 - o. NECA/NEIS-408: Recommended Practices for Installing Busway
 - p. NECA/NEIS-409: Recommended Practice for Installing and Maintaining Dry-Type Transformers
 - q. NEIS/NECA and IESNA-500: Recommended Practice for Installing indoor Commercial Lighting Systems
 - r. NEIS/NECA and IESNA-501: Recommended Practice for Installing Exterior Lighting Systems
 - s. NEIS and IESNA-502: Recommended Practice for Installing Industrial Lighting Systems
 - t. NECA/BICSI-568: Standards for Installing Commercial Building Telecommunications System
 - u. NECA/NEIS-600: Recommended Practice Installing Medium-Voltage Cable
- B. All material and equipment shall be new and shall be delivered to the site in unbroken packages. All material and equipment shall be listed and labeled by Underwriters Laboratories or other recognized testing laboratories, where such listings are available. Comply with all installation requirements and restrictions pertaining to such listings.
- C. Work and material shown on the drawings and in the specifications is new and included in the contract unless specifically indicated as existing or N.I.C. (not in contract).
- D. Keep a copy of all applicable codes and standards available at the job site at all times for reference while performing work under this contract. Nothing in plans or specifications shall be construed to permit work not conforming to the most stringent of building codes.
- E. Where a conflict or variation occurs between applicable Codes, standards and/or the Contract Documents, the provisions of the most restrictive provision shall become the requirement of the Contract Documents.

1.08 SUBMITTALS (ADDITIONAL REQUIREMENTS)

A. General

1. Review of CONTRACTOR'S submittals is for general conformance with the design concept of the project and general compliance with the information given in the contract documents. Any action shown is subject to the requirements of the plans and specifications. CONTRACTOR is responsible for quantities; dimensions which shall be confirmed and correlated at the job site; fabrication processes and techniques of construction; coordination of work with that of all other trades and satisfactory performance of their work.
2. The CONTRACTOR shall review each submittal in detail for compliance with the requirements of the contract documents prior to submittal. The CONTRACTOR shall "Ink Stamp" and sign each item of the submittal with a statement "CERTIFYING THE SUBMITTAL HAS BEEN REVIEWED BY THE CONTRACTOR AND COMPLIES WITH ALL THE REQUIREMENTS OF THE CONTRACT DOCUMENTS". The CONTRACTOR shall clearly and specifically identify each individual proposed substitution, substitution of equal, or proposed deviation from the requirements of the contract documents with a statement "THIS ITEM IS A SUBSTITUTION".
The burden of research, preparation of calculations and the furnishing of adequate and complete shop drawings information to demonstrate the suitability of CONTRACTOR's proposed substitutions and suitability of proposed deviations from the contract documents is the responsibility of the CONTRACTOR.
3. Departure from the submittal procedure will result in resubmittals and delays. Failure of the CONTRACTOR to comply with the submittal requirements shall render void any acceptance or any approval of the proposed variation. The CONTRACTOR shall then be required to provide the equipment or method without variation from the contract documents and without additional cost to the contract.
4. The CONTRACTOR at no additional cost or delays to the contract shall remove any work, material and correct any deficiencies resulting from deviations from the requirements of the contract documents not approved in advance by the DISTRICT prior to commencement of work.
5. Shop drawings submitted by the CONTRACTOR, which are not specifically required for submittal by the Contract Documents, or CONTRACTOR shop drawings previously reviewed and resubmitted without a written resubmittal request to the CONTRACTOR, will not be reviewed, considered, or commented on. The respective shop drawing submittal /resubmittal will not be returned to the CONTRACTOR and will be destroyed without comment or response to the CONTRACTOR. The respective submittal shall be considered null and void as being not in compliance with the requirements of the Contract Documents.
6. Refer to Division-1 for additional requirements.

B. Material Lists and Shop Drawings

1. Submit material list and equipment manufacturers for review within 35 days of award of contract. Give name of manufacturer and where applicable, brand name, type and/or catalog number of each item. Listing of more than one manufacturer for any one item of equipment, or listing items "as specified", without both make and model or type designation, is not acceptable. Shop drawings shall not be submitted before review completion of manufacturers list. The right is reserved to require submission of samples of any material whether or not particularly mentioned herein.
2. After completion of review of the material and equipment manufacturers list, submit shop drawings for review. Shop drawings shall be submitted in completed bound groups of materials (i.e., all lighting fixtures or all switchgear, etc.). The CONTRACTOR shall verify dimensions of equipment and be satisfied as to fit and that they comply with all code requirements relating to clear working space about electrical equipment prior to submitting shop drawings for review. Submittals, which are intended to be reviewed as substitution or departure from the contract documents, must be specifically noted as such. The

requirements of the contract documents shall prevail regardless of the acceptance of the submittal.

3. Shop drawings shall include catalog data sheets, instruction manuals, dimensioned plans, elevations, details, wiring diagrams, and descriptive literature of component parts where applicable. Structural calculations and mounting details, signed by a Structural ENGINEER registered by the State of California, shall be submitted for all equipment weighing over four hundred pounds, and shall be in compliance with Title 21 of the California Code of Regulations.
 4. Each shop drawing item shall be identified with the specification section and paragraph numbers, lighting fixture types and drawing sheet numbers; the specific shop drawing is intended to represent. Shop drawings 11-inches by 17-inches or smaller in size shall be bound in three (3) ring binders. Divider tabs shall be provided in the three (3) ring binders identifying and separating each separate shop drawing submittal item. Shop drawings larger than 11-inches by 17-inches, shop drawing pages/sheets submittals shall be sequentially numbered with unique alphanumeric numbering system to facilitate correspondence referencing identification of individual sheets.
 5. The time required to review and comment on the CONTRACTOR'S submittals will not be less than 14 calendar days, after receipt of the submittals at the office of FBA Engineering. The review of CONTRACTOR submittals and return to CONTRACTOR of submittals with review comments will occur in a timely manner conditioned upon the CONTRACTOR complying with all of the following:
 - a. The submittals contain complete and accurate information, complying with the requirements of the Contract Documents.
 - b. CONTRACTOR'S submittals are each marked with CONTRACTOR'S approval "stamp", and with CONTRACTOR signatures.
 - c. The submittals are received in accordance with a written, shop drawing submittal schedule for each submittal. The CONTRACTOR distributes the schedule not less than 35-calendar days in advance of the Shop Drawing Submittals, and the schedule identifies the calendar dates, the CONTRACTOR will deliver the various submittals for review.
 6. Shop drawings shall include the manufacturers projected days for shipment from the factory of completed equipment, after the CONTRACTOR releases the equipment for production. It shall be the responsibility of the CONTRACTOR to insure that all material and equipment is ordered in time to provide an orderly progression of the work. The CONTRACTOR shall notify the District's Representative of any changes in delivery, which would affect the project completion date.
 7. Submittal Identification
 - a. Each submittal shall be dated: with submittal transmission date; sequentially numbered and titled with submittal contents identification and applicable specification/drawing references (*i.e., Submittal dated: 5/12/98 Submittal #4 Contents: Branch circuit panelboards Sheet #E5.1 and transformers Specification Section 16050 Paragraph 2.11, etc.*).
 - b. Each resubmittal shall be dated: with original submittal date and resubmittal transmission dates; sequentially numbered with original submittal number and sequential resubmittal revision number and titled with submittal contents identification and applicable specifications/drawing references (*i.e., Original Submittal Date: 5/12/98 Resubmittal Date: 10/9/98 Original Submittal #4 resubmittal Revision R2 Contents: Transformer resubmittal Specification Section - 16050 Paragraph 2.11, etc.*).
 - c. Contractor shall provide a written response narrative with each resubmittal. Describe each response-action, resubmittal addition, change and deletion. Correspond each response to A/E specific review comment.
- C. The CONTRACTOR shall be responsible for incidental, direct and indirect costs resulting from the CONTRACTOR'S substitution of; or changes to; the specified contract materials and work.

- D. The CONTRACTOR shall pay, upon request by the District's Representative, a fee for the District's Representative time involved in the review of substitution submittals and design changes resulting from the CONTRACTOR'S requested substitutions. The fee shall be not less than \$125.00 per hour but, in no case, less than stated in Division-1, whichever is greater.
- E. Maintenance and Operating Manuals
 - 1. The CONTRACTOR shall furnish three (3) copies of type-written maintenance and operating manuals for all electrical equipment, fire alarm equipment, sound system equipment, etc., to the District.
 - 2. Instruct the District's personnel in correct operation of all equipment at completion of project. Provide the quantity and duration of instruction class as specified; but in no case less than two (2) 4-hour duration separate instruction classes for each individual equipment group furnished as part of the contract. Instruction classes shall be presented by Manufacturer's authorized field service ENGINEER at the project site. Instruction class size shall be at the District's discretion, not less than one (1) or more than fifteen (15) students shall attend each instruction session. Submit fifteen (15) written outline copies of the proposed instruction class curriculum, 14-days prior to the class-scheduled dates.
 - 3. Maintenance and operating manuals shall be bound in three-ring, hard-cover, plastic binders with table of contents. Manuals shall be delivered to the District's Representative, with an itemized receipt.
- F. Portable or Detachable Parts: The CONTRACTOR shall retain in his possession, and shall be responsible for all portable and detachable parts or portions of the installation such as fuses, keys, locks, adapters, locking clips, and inserts until final completion of contract work. These parts shall then be delivered to the District's Representative with an itemized receipt.
- G. Record Drawings (ADDITIONAL REQUIREMENTS)
 - 1. Provide and maintain in good order a complete set of electrical contract "record" prints. Changes to the contract to be clearly recorded on this set of prints. At the end of the project, transfer all changes to one set of transparencies to be delivered unfolded to the District's Representative.
 - 2. The actual location and elevation of all buried lines, boxes, monuments, vaults, stub-outs and other provisions for future connections shall be referenced to the building lines or other clearly established base lines and to approved bench marks. If any necessary dimensions are omitted from the record drawings, the CONTRACTOR shall, at THE Contractor's own expense, do all excavation required to expose the buried work and to establish the correct locations.
 - 3. The CONTRACTOR shall keep the "record" prints up to date and current with all work performed.
 - 4. Refer to Division-1 for additional requirements.

1.09 CLEANING EQUIPMENT, MATERIALS, PREMISES

All parts of the equipment shall be thoroughly cleaned of dirt, rust, cement, plaster, etc., and all cracks and corners scraped out clean. Surfaces to be painted shall be carefully cleaned of grease and oil spots and left smooth, clean and in proper condition to receive paint finish.

1.10 JOB CONDITIONS - PROTECTION

Protect all work, materials and equipment from damage from any cause whatever and provide adequate and proper storage facilities during the progress of the work. Provide for the safety and good condition of all the work until final acceptance of the work by the District and replace all damaged or defective work, materials, and equipment before requesting final acceptance.

1.11 EXCAVATION, CUTTING, BACKFILL AND PATCHING ADDITIONAL REQUIREMENTS

A. General

1. Perform excavation, cutting, backfill, core drilling, directional boring, and patching of the construction work required for the proper installation of the electrical work.
2. Patching shall be of the same material, thickness, workmanship, and finish as existing and accurately match-surrounding work to the satisfaction of the District's Representative.
3. Prior to penetrating, coring, drilling or cutting existing building elements, concrete and/or masonry, provide imaging equipment examinations of each specific location. The imaging process shall identify existing internal embedded components and locations, including structural elements/anchors, conduit, and piping that are present. Do not penetrate or damage the existing internal embedded elements. Imaging shall employ one (1) of the following, with GPR methodology preferred:
 - a. Non-invasive imaging employing high frequency, ground penetrating radar (GPR), single side echo reflection technology.
 - b. Non-invasive imaging employing x-ray radiography, through-and-through imaging technology.

B. Excavation Temporary Cover

1. Excavations for contract work occurring in streets, vehicular drive areas, parking lots, sidewalks; any paved surface; or any area accessible to the public; provide temporary steel plating and shoring support for the plates, to completely cover the excavations under one or more of the following conditions:
 - a. Excavation shall not remain "open" for more than 4-calendar days; provide temporary plating.
 - b. Excavation shall not be "open" over weekends (Saturday, Sunday) or Holidays; provide temporary plating.
2. The temporary plating shall be a minimum of 0.75-inch thickness steel, but in no case shall the thickness be less than required to support AASHO-H20 traffic loading.
3. Provide a minimum of two (2) 100% open lane(s) (12-foot lane width) for vehicular traffic at all times during construction, for vehicle access to all areas.

1.12 IDENTIFICATION

A. Equipment Nameplates

1. Panelboards, terminal cabinets, circuit breakers, disconnect switches, starters, relays, time switches, contactors, push-button control stations, and other apparatus used for the operation or control of feeders, circuits, appliances, or equipment shall be properly identified by means of descriptive nameplates or tags permanently attached to the apparatus and wiring.
2. Provide nameplate label on electrical service entrance equipment describing available short circuit information calculated by the CONTRACTOR, including:
 - a. Calculation date, month-day-year.
 - b. Calculate maximum available short circuit fault current.
 - c. Description of parameters and changes affecting the requirements for recalculation of the fault current information.
3. Electrical equipment including switchgear, switchboards, electric panels and control panels, motor control centers, combination motor starters, transformers, disconnects, etc., shall each be labeled by the manufacturer with "Electric-ARC-FLASH" warning signs. The signs shall explain a hazard to personnel may exist if the equipment is worked on while energized or operated by personnel while energized. The sign shall instruct personnel to wear the correct protective equipment/clothing (PPE) when working "Live", or operating "Live" electrical equipment and circuits.
4. Nameplates shall be engraved laminated phenolic. Shop drawings with dimensions and format shall be submitted before installation. Attachment to equipment shall be with

escutcheon pins, rivets, self-tapping screws or machine screws. Self-adhering or adhesive backed nameplates shall not be used.

5. Provide black-on-white laminated plastic nameplates engraved in minimum ¼-inch high letters to correspond with the designations on the drawings. Provide other or additional information on nameplates where indicated.
- B. Plates: All cover and device plates shall be furnished with engraved or etched designations under any one of the following conditions (minimum character size not less than 0.188 inch. Engraving shall indicate circuits and equipment controlled or connected):
1. More than two (2) devices under a common coverplate.
 2. Lock switches.
 3. Pilot switches.
 4. Switches in locations from which the equipment or circuits controlled cannot be readily seen.
 5. Manual motor starting switches.
 6. Where so indicated on the drawings.
 7. As required on all control circuit switches, such as heater controls, motor controls, etc.
 8. Receptacles other than standard 15 ampere 120 volt duplex receptacles; shall indicate circuit voltage, ampere, phase and source circuit number.
 9. Where outlets or switches are connected to emergency power circuit; provide panelboard and circuit number engraved on plate.
 10. Low voltage and signal system outlets.
- C. For equipment and access doors or gates to equipment containing or operating on circuits of more than 100 volts AC or DC nominal. Provide red-on-white laminated warning signs engraved in ½-inch high letters to read: "DANGER - 480 (*or applicable voltage*) VOLTS KEEP OUT AUTHORIZED PERSONNEL ONLY".
- D. Wire and Cable Identification
1. Provide identification on individual wire and cable including signal systems, fire alarm, electrical power systems (each individual phase, neutral and ground), empty conduit pull ropes, and controls circuit.
 2. Permanent identification shall be provided at each termination location, splice location, pullbox, junction box and equipment enclosure.
 - a. Individual wire and cable larger than #6AWG or 0.25-inch diameter, shall be provided with polypropylene identification tag holders, with yellow polypropylene tags interchangeable black alphanumeric characters, character height 0.25 inch. Attach identification tags with plastic "tie" wraps, minimum of two (2) for each tag. As manufactured by Almetek Industries-"EZTAG" series; or TECH Products - "EVERLAST" series.
 - b. Individual wire and cable #6AWG and smaller or smaller than 0.25 inch diameter, shall be provided with water and oil resistant, flexible, self-laminating pressure sensitive machine embossed plastic tags that wrap a minimum of 360 degrees around the wire/cable diameter. The entire tag shall then be covered with a clear flexible waterproof plastic cover wrapped a minimum of 540 degrees around the wire/cable diameter and completely covering the identification. As manufactured by Brady Identification; or 3M; or Panduit.
 - c. Each identification tag location shall indicate the following information: circuit number, circuit phase, source termination and destination termination equipment name (or outlet number as applicable).
 3. Install permanent identification after installation /pulling of wire/cable is complete, to prevent loss or damage to the identification.
- E. Cardholders and cards shall be provided for circuit identification in panelboards. Cardholders shall consist of a metal frame retaining a clear plastic cover permanently attached to the inside

of panel door. List of circuits shall be typewritten on card. Circuit description shall include name or number of circuit, area, and connected load.

- F. Junction and pull boxes shall have covers stenciled with box number when shown on the drawings, or circuit numbers according to panel schedule. Data shall be lettered in a conspicuous manner with a color contrasting to finish.

1.13 TESTING

- A. The CONTRACTOR shall obtain an independent testing laboratory, provide all instrumentation and perform tests on the electrical system and equipment as hereinafter described and further directed by the District's Representative. The test shall be performed after the completion of all electrical systems included in the Contract Scope of Work. All tests shall be recorded and documented and submitted to the District's Representative for review.
1. All equipment and personnel required for set-up and testing shall be provided by the CONTRACTOR.
- B. Test for Phase to Ground and Neutral Condition:
1. Open main service disconnects.
 2. Isolate the system neutral from ground by removing the neutral disconnects link located in the service switchboard.
 3. Close all submain disconnects.
 4. Close all branch feeder circuit breakers.
 5. Turn all switches to "on" position, unplug all portable equipment from outlet receptacles.
 6. Measure the resistance of each phase to ground and phase to neutral. A properly calibrated "megger" type test instrument shall be used. The test voltage shall be a nominal 500 volts.
 7. Record all readings after 1-minute duration and document into a complete report.
 8. Isolating Grounds: In the event that low resistance ground neutral connections are found in the system, they shall be isolated and located by testing each circuit individually as outlined above. Make proper corrections to restore the resistance values to an acceptable value.
- C. Method of obtaining ground resistance shall be in accordance with the latest edition of the James G. Biddle (Plymouth Meeting, Pennsylvania) manual published on this subject.
1. Perform "fall-of-potential" three (3) point tests on the main grounding electrode of system per IEEE Standard No. 81, Section 8.2.1.5. when suitable locations for test rods are not available, a low resistance dead earth or reference ground shall be utilized.
 2. Perform the two (2) point method test per IEEE Standard No. 81, Section 8.2.1.1, to determine the ground resistance between the main grounding system and all major electrical equipment frames, system neutral, and/or derived neutral points.
- D. The testing, calibrating and setting of all ground and ground fault equipment, circuit breakers, circuit device protection relays, and meters adjustable settings shall be by an independent testing laboratory. Set as recommended by the respective manufacturer and coordination study so as to be coordinated with other protection devices within the electrical design. Bound and tabulated copies of the test and settings shall be sent to the District's Representative.
- E. Ampere and Voltage Measurements
1. Measure and record ampere and line voltage measurements under full load on all panel feeders, switchboard, and switchgear feeders, motor control centers and motor circuits provided in the contract. Record measurements at the equipment tested and submit to the District's Representative for review.
 2. Ampere voltage readings shall be:
 - a. Phase A-B, A-C and B-C.
 - b. Phase A-Neutral, B-Neutral and C-Neutral.
 3. The ampere and voltage readings shall be not less than 20-minutes duration for each test. Record and submit the measured minimum, maximum and 20-minute average for each

ampere and voltage value and test location. Voltage and ampere measurements shall occur at the connected load end of each respective feeder, not at the source of supply end of each feeder.

4. Test equipment shall be accurate within plus or minus 1%.
 5. Branch circuit devices 40 ampere or less and motor loads ten (10) horsepower or smaller are excluded from ampere and voltage testing requirement.
 6. If, in the opinion of the District's Representative, the voltages and regulations are not met within acceptable limits, make arrangements with the serving utility for proper electrical service. Retest feeder line voltages, and submit to District's Representative for review, after the utility company has completed corrective actions. Reset "voltage taps" on transformers provided or modified as part of the contract work, to adjust line voltages to within acceptable values, as directed by the District's Representative.
- F. The Contractor shall complete the following work before any electrical equipment is energized.
1. All equipment shall be permanently anchored.
 2. All bus connections and conductor/wire connections shall be tightened per manufacturer's instructions and witnessed by the District's Representative.
 3. All ground connections shall be completed and identified. Perform and successfully complete all required megger and ground resistance tests.
 4. Feeders shall be connected and identified.
 5. The interiors of all electrical enclosures including busbars and wiring terminals shall be cleaned of all loose material and debris, paint, plaster, cleaners or other abrasive's over spray removed and equipment vacuumed clean. The District's Representative shall observe all interiors before covers are installed.
 6. All wall, ceiling, and floor work and painting shall be completed within areas containing electrical equipment prior to installation of equipment. The equipment indoor rooms and spaces shall be weather-tight and weather protected from environmental incursions.
 7. All doors to electrical equipment rooms shall be provided with locks in order to restrict access to energized equipment.
 8. Electrical spaces and rooms shall not be used as storage rooms after power is energized.
 9. Outdoor electrical equipment enclosures and housings shall be weather protected.
 10. The electrical system time current coordination and ARC-Fault study shall be complete for circuit breakers, ground relays sets, and circuit relay sets, fuses; set-up, tested and calibrated accordingly.

1.14 COMMISSIONING - Cx

A. General

1. The commissioning shall verify the electrical systems for the term of the contract, by observation; and by calibration; and by testing. The commissioning shall ensure the electrical systems perform interactively and correctly, according to the contract and operational requirements.
2. Commissioning shall provide startup, testing and documented confirmation of the contract constructed systems, materials and work, functions in compliance within the criteria set forth in the Contract Documents to the satisfaction of the District's needs. The commissioning scope shall encompass each system identified as requiring "commissioning" by the Contract Documents, including but not limited to:
 - a. Electrical circuits' protection, short circuit, overcurrent, and ground fault devices.
 - b. Electrical circuits monitoring and metering.
 - c. Light fixtures, lamps and ballasts.
 - d. Lighting control devices, equipment and lighting control systems.
 - e. Standby and emergency electric power supply equipment and systems.
 - f. Fire alarm, equipment, devices and fire alarm systems.
 - g. Additional systems described in the contract documents.

3. Commissioning process shall review all of the shop drawing submittals, including:
 - a. Controls, operation and maintenance requirements.
 - b. Facility performance testing compliance.
 - c. Project contract requirements compliance.
 - d. Compliance with basis for design and operational descriptions provided in the contract.
4. Commissioning shall be the process of ensuring all the systems described in the Contract Documents comply with the Contract Document design; all systems are installed properly; all systems are functional, tested and capable of being operated and maintained to perform within the contract requirements and design intent.
5. Functional setup, recalibration, correcting deficiencies, retesting and the associated costs, for system(s) that fail commissioning, shall be the responsibility of the CONTRACTOR. The CONTRACTOR shall include all commissioning costs in the contract scope of work.
6. Complete all commissioning functions prior to the occupancy of the facility by the District, unless directed otherwise by the District's Representative.
7. Submit three (3) copies of commissioning documentation to District's Representative.
8. Commissioning, unless specifically indicated otherwise, shall be performed by factory-trained technician(s) authorized and certified by the Manufacturers of the respective equipment/systems. Where specifically indicated, commissioning shall be performed by Independent Test Lab.

B. Commissioning Procedures

1. Prepare a commissioning matrix identifying components and systems included in the commissioning scope; the status; actions completed and actions to be completed.
2. Verify CONTRACTOR compliance with Contract Document requirements manufacturer's recommendations and approved shop drawings.
3. Perform startup, functional tests, reports, and document results.
4. Evaluate and document the setup parameters, software, operating condition and performance of each system at the time of functional test completion. Document and record each performance parameter and condition, in the commissioning report.
5. Schedule testing and prepare descriptions of testing.
6. Describe measures performed to correct deficiencies.
7. Verify that instructions to District's Representatives, Operations and maintenance manuals comply with Contract Documents.
8. Prepare warranty matrix identifying the start dates, expiration dates, routine preventative maintenance dates and the District's responsibility for performing preventative maintenance and keeping logs for each maintenance function and warranty claims.
9. Confirm completion of all punch list items that have been acceptably accomplished and a list of what has not been acceptably completed.
10. Describe uncorrected deficiencies accepted by the DISTRICT.

C. Commissioning Phasing

The commissioning phases of work shall include the following activities:

1. SDQ - Shop Drawing Qualification shall verify complete and correct shop drawings have been submitted.
2. IQ - The Installation Qualification of contract work shall verify systems are correctly and properly installed.
3. OQ - Verify systems interfaces and software are correctly and properly operational.
4. ITM - Verify the contract Inspection, Testing and procedures for Maintenance are complete.
5. PQ - Performance Qualification complete the functional performance testing to validate each building system.

1.15 POWER OUTAGES

- A. All electrical services in all occupied facilities of the contract work are to remain operational during the entire contract period. Any interruption of the electrical services for the performance of this work shall be at the convenience of the District and performed only after consultation with the District's Representative. Work involving circuit outages shall be only at such a time and of such a duration as approved in writing. Work involving circuit outages for the work required to connect new equipment and disconnect existing equipment shall be performed at the convenience of the DISTRICT Representative, with approval in writing.
- B. Contract work involving outages or disruption of normal function in electrical power systems, telephone/communication systems, fire alarms, shall be performed during the following time periods. The contract work shall be phased to limit outages in the respective systems to the stated periods:
 - 1. 11:30 p.m. Friday to 11:30 p.m. Sunday of the same weekend. Work shall occur on multiple weekend periods if a single weekend is not sufficient time to complete the work.
 - 2. The contract work involving outages shall be phased in multiple work time units, to comply with the permitted outage limitations.
- C. Work involving system outages to the building fire alarm system shall be performed only after consultation with the DISTRICT and shall be only at such a time and of such duration as approved in writing. Contractor shall provide continuous "Fire-Watch" during fire alarm system outages and comply with AHJ "Fire-Watch" requirements.
- D. Provide overtime work; double shift work; night time work; Saturday, Sunday, and holiday work to meet outages schedule.
- E. Provide temporary electrical power to meet the requirements of this Article.
- F. Any added costs to CONTRACTOR due to necessity of complying with this Article shall be included in the Contract Scope of Work.
- G. When electrical work involving power disruptions to existing areas is initiated, the work shall proceed on a continuous basis without stopping until electric power is restored to the affected areas.
- H. The CONTRACTOR shall request in writing to the DISTRICT'S Representative a minimum of 3-weeks in advance, for any proposed electrical outage.

1.16 TEMPORARY ELECTRICAL POWER

- A. Provide temporary electrical power if work requiring power outages cannot be completed in time permitted and approved by the DISTRICT'S Representative.
- B. Temporary electrical power shall be a standby diesel engine generators. Voltage, frequency, regulation, etc. shall be equal to that of normal utility source. Exhaust system shall have a critical silencing muffler. Generator voltage shall match the existing secondary voltage required at the site. The CONTRACTOR shall furnish all necessary cables, switches, etc., to make all required

Connections to existing panels, feeders, etc. Generator shall be sized to adequately carry the demand load. If record of demand load is not available, size generator to match corresponding transformer, maximum capacity circuit as directed by the District's Representative.
- C. After completion of required usage of the temporary generators, prior to completion of the project, the CONTRACTOR shall remove the generators. All temporary cables, switches, etc. shall be removed and all permanent equipment left in satisfactory condition.

- D. Each generator shall be housed in security type sound attenuated housing to prevent access by unauthorized personnel. Temporary power cables, connections, etc. shall be protected from unauthorized personnel.
- E. The CONTRACTOR shall be responsible for complete operation of the generator including personnel, fuel supplies, proper safety precautions, etc. Generator shall not be left unattended while in operation.
- F. The CONTRACTOR shall provide temporary construction lighting and power as required in areas where work is being performed. Temporary power arrangements, outages, installation, work schedules, etc., shall be submitted in writing 3-weeks prior to requested outage date, and approved by the DISTRICT'S Representative prior to start of work.

1.17 ASBESTOS, POLYCHLORINATED BIPHENYL (PCB) OR HAZARDOUS WASTE:

- A. It is understood and agreed that this contract does not contemplate the handling of asbestos, PCB or any hazardous waste material. If asbestos, PCB or any hazardous waste material is encountered, notify the District's Representative immediately. Do not disturb, handle or attempt to remove.
- B. Lighting Fixture Demolition Hazardous Materials
 - 1. The removal of existing lighting fixtures will generate hazardous material waste disposal contract documents.
 - a. The existing lighting fixture ballast contains PCB material.
 - b. The existing lighting fixture lamps contain mercury.
 - c. The existing lighting fixture internal wire insulation may contain asbestos.
 - 2. Remove, handle, store, contain, dispose of and document the hazardous materials resulting from existing lighting fixtures work, as part of the contract requirements.

1.18 TIME/CURRENT COORDINATION, SHORT CIRCUIT, ARC-FLASH AND SERIES RATED EQUIPMENT

- A. Series rated equipment.
 - 1. Circuit protective Devices identified as "Series Rated" or "Current Limiting" (i.e., CLCB - current limiting circuit breaker; CLF - current limiting fuse, etc.) shall be series rated and tested (UL 489 and CSA5) by the manufacturer with all equipment and circuit protective devices installed down stream of the identified series rated or current limiting device.
 - 2. Provide nameplates on all equipment located down stream, including the CLCB and CLF devices, to comply with CEC/NEC paragraphs 110-22 and 240-83 "CAUTION SERIES RATED SYSTEM - NEW DEVICE INSTALLATIONS AND REPLACEMENTS SHALL BE THE SAME MANUFACTURER AND MODELS".
- B. Short circuit, coordination and ARC-Flash
 - 1. Perform engineering analysis and submit engineered settings for each equipment location, fuse and circuit breaker device, showing the correct time and current settings to provide the selective coordination within the limits of the specified equipment. Shall comply with the latest application standards of IEEE and ANSI. Provide electrical system short circuit worst case bolted-fault analysis, both 3-phase line-to-line and 1-phase line-to-ground calculations as part of the coordination analysis recommendations. Provide Electric ARC-FLASH calculations as part of the coordination analysis recommendations.
 - 2. The information shall be submitted in both tabular form and on time current log-log graph paper, with an engineering narrative. Written narrative describing data, assumptions, analysis of results and prioritized recommendations, six (6) copies.

3. The goal is to minimize an unexpected but necessary electrical system outage and personnel exposure to the smallest extent possible within the fault occurrence location, using the specified contract equipment. Shall comply with, but not limited to:
 - a. IEEE-242, Recommended Practices for Protection and Coordination of Industrial and Commercial Distribution.
 - b. IEEE-399, Recommended Practices for Industrial and Commercial Power System Analysis.
 - c. IEEE-1584, Guide to Performing ARC-FLASH Hazard Study.
 - d. CEC/NEC
4. Provide permanent warning labels on each equipment location. The labels shall describe ARC-FLASH, Short-Circuit and Time/Current Coordination, including safety precautions and protective clothing. Also described actions to be taken if any circuit changes or equipment modifications occur.
5. Shall be submitted with the shop drawing submittals for the respective equipment.

1.19 INDEPENDENT TESTING LABORATORY

A. Testing Laboratories Definition

1. The Testing Laboratory shall meet Federal OSHA criteria for accreditation of Nationally Recognized Testing Laboratories (NRTL) Title 29 Part 1907 and 29 CFR-1910.
2. Membership in the National Electrical Testing Association (NETA) shall also constitute acceptance of meeting said criteria, for testing of electrical systems.

1.20 SPARE FUSES

Provide three (3) spare fuses [for each size and type] [at each location] to match the installed fuses where the fuses are provided as part of the Contract. Provide spare fuse holders on inside door of each respective fuse compartment. Provide engraved nameplate on front of fuse access door indicating fuse type/catalog number ampere rating and manufacturer of fuse.

1.21 EQUIPMENT SEISMIC AND WIND LOAD REQUIREMENTS (ADDITIONAL REQUIREMENTS)

A. Seismic Performance and Seismic Restraint Requirements

1. Shall be based on the following:
 - a. Soils Site Class: ***
 - b. Design Spectral Response Acceleration: ***
 - c. Seismic Design Category: ***
 - d. Building Component Importance Factor: ***
 - e. Building Occupancy Category: ***
 - f. Mapped Spectral Accelerations: ***
 - g. Damped Design Spectral Response Accelerations: ***
2. Refer to Structural, Architectural, and Soils report contract documents for additional requirements.

B. General

1. Equipment supports and anchorage's provided as part of the contract shall be designed, constructed and installed in accordance with the earthquake regulations of the California Building Code (CBC), International Building Code (IBC).
2. Provide equipment anchorage details, coordinated with the equipment mounting provision, prepared, signed and "stamped" with PE registration in good standing, by a Civil or Structural Engineer licensed as a Professional Engineer (PE) in the State of California.
3. Mounting recommendations shall be provided by the manufacturer based upon approved shake-table tests used to verify the seismic design of that type of equipment.
4. The equipment manufacturer shall document the details necessary for proper wind-load and seismic mounting, anchorage, and bracing of the equipment for floor, ceiling, and wall/back installation location.

5. Seismic performance shall be based on actual install location of the respective equipment in the building and height above or below grade.
6. The seismic requirements are typical for each equipment item exceeding 19-pounds, including but not limited to the following:
 - a. Switchgear, switchboards, and motor control equipment
 - b. Transformers
 - c. Equipment racks and terminal cabinets
 - d. Panels
 - e. Conduits with floor, ceiling or wall attachment support and conduits with suspension attachments.
 - f. Busway, wire way and cable tray
 - g. Uninterruptable power supplies (UPS)
 - h. Inverters
 - i. Generators and related equipment
 - j. Lighting equipment
 - k. Fire alarm equipment

C. Certification

1. Electrical equipment manufacturers and Contractor shall provide Special Seismic Certification (SCC) for each specific equipment configuration with shake-table verification, all furnished as part of the contract documents requirements. The SCC shall include the specific installation location characteristics of the respective equipment including as follows:
 - a. Ground or floor attachment
 - b. Wall attachment
 - c. Ceiling attachment
 - d. Roof attachment
2. Wind Loading
 Electrical equipment and anchorages shall withstand the wind-load imposed at the install location. Wind loading withstand requirements shall apply to all electrical equipment installed in outdoor locations and to all electrical equipment exposed to the weather. The equipment shall be tested and certified by the manufacturer and Contractor. The wind-load withstand qualification of the equipment and anchorages shall be verified by the following methods:
 - a. Aero-dynamic wind tunnel test method.
 - b. Analytical calculation method, for oversized equipment too large for wind tunnel test method.
3. The wind-load withstand rating and the SCC shall comply with the requirements of the Authority Having Jurisdiction (AHJ), and include the latest revisions, but not limited to the following:
 - a. American Society of Civil Engineers; ASCE-7
 - b. CBC/IBC; including but not limited to Sections 1702, 1708, 1709, 1708A and 1709A.
 - c. California Office of Statewide Health Planning and Development OSHPD; OPA-Preapproval of Anchorage; Code Application Notice CAN 2-1708A.5 and OSP-Special Seismic Certification Approval
 - d. US Department of Homeland Security; FEMA- (installing seismic restraints for electrical equipment)

D. Wall Mounted Electrical Equipment

1. Surface Mounted Equipment
 - a. Provide multiple horizontal sections of metal "C" channels for support and attaching wall mounted equipment to walls. Channels shall provide "turned lips" at longitudinal edges to hold "lock-in" fasteners and shall comply with ANSI-1008 and ASTM-A569 latest revision. The channels shall be steel hot dip zinc galvanized. As manufactured by Unistrut or Kindorf.

- b. The "C" channels shall be positioned horizontally within 3-inches of the top and bottom of each, equipment section cabinet and located behind each equipment vertical section. Provide additional intermediate "C" channels at not less than 36-inches on center between the "top" and "bottom" "C" channel positions, located behind each equipment vertical section.
 - c. The "C" channels shall be of sufficient length to provide connection to not less than two (2) vertical structural wall framing elements separated by not less than 16-inches; but in no case shall the "C" channel length be less than the width of the respective equipment section.
 - d. Attach the "C" channels to the wall structural elements after the wall, finish surface, installation (including painting) is complete.
 - e. Attach the "C" channels with fasteners to the building wall framing structural elements as follows: welded to steel framing; bolted to wood framing; cast in place concrete inserts for masonry and concrete construction; drilled "afterset" expansion anchors for existing masonry and concrete construction.
 - f. Attach the equipment to the "C" channels with threaded and bolted fasteners to "pre-locate" and lock into the channel "turned lips" and channel walls.
2. Flush mount equipment
 - a. Provide anchor attachment of equipment into adjacent wall structural elements.

E. Housekeeping Pad

1. Provide cast-in-place, steel re-enforced concrete raised "housekeeping" pads under all floor standing electrical equipment (except data network equipment racks).
2. Pad sizes
 - a. The raised housekeeping pad height shall extend 4-inches above the surrounding finished floor elevation for interior building locations.
 - b. The pad shall extend 8-inches below finish grade plus 4-inches above finish grade for outdoor equipment location on grade.
 - c. The pads shall extend 7-inches past the "footprint" edge of the respective floor standing equipment.
3. Anchor equipment to pads. Anchor pads to the building structural floor. Equipment pad, equipment re-enforcing and equipment anchoring shall comply with seismic earthquake requirements and wind load requirements.
4. Unless shown otherwise on drawings. The equipment housekeeping pad steel re-enforcing shall consist of two (2) layers of number 4-size steel-rebar laid horizontally and uniformly spaced 6-inches on center. Position rebar in two (2) directions (90-degrees opposed) and centered inside the concrete house keeping pad. Horizontal rebar shall extend to within 3-inches of the edge of the concrete pad in all directions. Metal wire "tie-wrap" shall be provided at each rebar crossing.
5. Equipment anchor attachments shall extend through the housekeeping pad and into the structural concrete below the pad a minimum of not less than 2-inches.

1.22 ELECTRICAL WORK CLOSEOUT

- A. Prepare the following items and submit to the District's Representative before final acceptance.
 1. Two (2) copies of all test results as required under this section.
 2. Two (2) copies of local and/or state code enforcing authorities final inspection certificates.
 3. Copies of record drawings as required under the General Conditions, pertinent Division One Sections and Electrical General Provisions.
 4. Two (2) copies of all receipts transferring portable or detachable parts to the DISTRICT'S Representative when requested.
 5. Notify the District's Representative in writing when installation is complete and that a final inspection of this work can be performed. In the event any defect or deficiencies are found during this final inspection they shall be corrected to the satisfaction of the District's Representative before final acceptance can be issued.
 6. List of spare fuses and locations identified by equipment name and building designation.

7. Prior to energizing, retighten to the proper torque, each circuit conductor lug landing, each bus bar (phases, neutral and ground) and circuit protection device threaded connections in all switchboards, switchgear, motor control centers, transformers, busways, disconnect switches, motor starters, motor terminals and panelboards, after the equipment is installed/ connected and prior to energizing the equipment. The torque values shall comply with manufacturer's recommendations.
- B. Electrical power single line diagrams – SLD
1. Provide single line diagrams showing the contract document work complete electrical power system (normal and emergency). SLD shall show inter-connection circuits, electrical equipment, panels, and circuit protection devices, nominal 50% (½-size) approximately 18-inches by 24-inches. Show installed voltages and electrical capacity sizes.
 2. SLD shall be mounted in metal (picture frame) rigid enclosure frame with rigid-backing (backer-board) and clear/transparent front, for hanging on wall. Provide clear transparent cover over SLD inside the frame.
 3. Provide a wall-hung (48-inches) SLD in each “main” and “sub” electrical equipment room. If wall space is limited, alternatively securely attach SLD frame to room door facing into the respective electrical room.

END OF SECTION

SECTION 26 05 15

BASIC ELECTRICAL MATERIALS AND METHODS

PART1 GENERAL

1.01 SCOPE

- A. Work Included: All labor, materials, appliances, tools, equipment, facilities, transportation and services necessary for and incidental to performing all operations in connection with furnishing, delivery and installation of the work of this Section, complete as shown on the drawings and/or specified herein. Work includes, but is not necessarily limited to the following:
 - 1. Examine all other sections for work related to those other sections and required to be included as work under this section.
 - 2. General provisions and requirements for electrical work.

1.02 SUBMITTALS (ADDITIONAL REQUIREMENTS}

- A. Submit product data sheets for all outlet boxes, floor boxes, wiring devices, device plates, relays, contactors, timeswitches, and disconnects fuses.
- B. Submit detailed shop drawings including dimensioned plans, elevations, details, schematic and point-to-point wiring diagrams and descriptive literature for all component parts for transformers, relays, time clocks, and photocells.
- C. Submit transformer test reports.
- D. Submit material list for outlet boxes.

PART 2 PRODUCTS

2.01 OUTLET AND JUNCTION BOXES

- A. General
 - 1. Flush or concealed outlet and junction boxes: Pressed steel, steel thickness not less than 0.062-inch, hot-dip galvanized, knockout (KO) type with conduit entrances and quantities size to match conduits shown connecting to respective outlet box. U.L.-514 listed and labeled. Minimum required box depth is exclusive of extension-ring depth.
 - 2. Provide boxes of proper code size for the number of wires or conduits passing through or terminating therein, but in no case shall box be less than 4.0 inch square by 2.125 inch deep, unless specified elsewhere or noted otherwise on the drawings. 2.5 inch minimum depth for box widths exceeding 2-gang.
 - 3. Increase the minimum outlet box size to 4.69 inches square by not less than 2.125 inches deep, where one or more of the following conditions occurs:
 - a. More than two (2) conduits connect to the outlet box.
 - b. Conduit "homerun" connects to outlet box.
 - 4. Provide extension rings on flush outlets to finish face of extension ring flush with finished building surfaces. Extension ring shall match outlet box construction and contain "attachment mounting-tabs" for wiring devices. Extension rings shall be "screw-attached" to respective outlet box and maintain "ground" bonding continuity.
 - 5. Boxes installed in masonry or concrete shall be U.L. "concrete-tight" approved for installation in concrete, and shall allow the placing of conduit without displacing reinforcing bars.
 - 6. Provide fixture-supporting device in outlet boxes for surface mounted fixtures as required.
 - 7. Provide solid gang boxes for three or more switches, for mounting behind a common device plate.
 - 8. Provide barriers for all 277 volt devices, between line voltage and low voltage devices and where more than one device is installed in an outlet box.

9. Individual audio/visual, telephone, computer or data outlets: 4.69 inch square by 2.125 inch deep minimum with two gang extension ring on flush boxes.
10. Combination signal/telephone/data or computer outlets: 4.69 inch square by 2.125 inch deep minimum with 2-gang wide extension ring on flush boxes.

B. Surface Outlet Boxes

1. Surface mounted outlet boxes, cast iron Type FS or FD, with threaded hubs as required. Box interior dimensions and interior volume capacity not less than required for "press steel boxes", and "sheet steel boxes". Provide plugs in all unused openings. Provide vyeatherproof gaskets for all exterior boxes.

C. Floor Boxes and Outlets

1. Recessed Combination Power/Signal Floor Box
 - a. Floor box shall be cast iron, UL listed for concrete installation with leveling screws. Walker "Resource" RFB4-CI Series or equal.
 - b. Floor box shall be listed for thru wiring.
 - c. Floor box shall contain four independent, barriered wiring compartments.
 - d. Overall dimensions shall not exceed 14 1/2" long x 11" 7/8" wide x 3 1/2" deep.
 - e. Box cover shall be flush with floor and shall provide wire/cable egress points through cover notches. The trim and cover shall be of metal composition. Covers shall be hinged. Walker RAKMTR-BUFF Series or equal.
 - f. Unit shall include two duplex receptacles as herein specified and two signal system outlets. Walker CIHT-D and CILT-2T.
 - g. Activation assemblies shall include device mounting brackets, access plates, grommets, partitions, adjusting rings and all associated hardware.

2.02 PULL BOXES

- A. Sizes as indicated on the drawings and in no case of less size or material thickness than required by the governing code. Exercise care in locating underground pull boxes to avoid installation in drain water flow areas.
 1. General purpose sheet steel pull boxes: Install only in dry protected locations with removable screw covers. Manufacturer's standard baked enamel finishes.
 2. Weatherproof sheet steel pull boxes: Fabricate of code gauge, hot-dip galvanized steel with gasketed weathertight cover of same material. Manufacturer's standard baked exterior enamel finish.

2.03 SWITCHES

- A. Provide circuit switches totally enclosed, Bakelite or composition base, toggle type with 277 volt A.C. rating for full capacity or contacts for incandescent or fluorescent lamp loads. Switch ratings shall be 20 ampere only. Color as selected by OWNER'S REPRESENTATIVE. Switches controlling circuits connected to emergency power shall be red.

- B. Where switches are mounted in multiple gang assembly and are operating at 277 volts and/or 277 volts and 120 volts mounted in same outlet box, there shall be a barrier installed between each switch.

C. Switches – Specification Grade Commercial Series

1. Single Pole Switches

	Toggle Type	Lock Type
<u>Make</u>	<u>20 Amps</u>	<u>20Amps</u>
Hubbell	#CS1221	#CS1221-L

2. Double Pole Switch
Hubbell #CS1222 #CS1222-L

3. Three-Way Switches
Hubbell #CS1223 #CS1223

4. Four-Way Switches

Hubbell #CS1224 #CS1224-L

5. Momentary Contact Switches- 20A at 277V
Hubbell 3'-Position Req. 3-Position Lock
#1557 #1557-L

6. Maintained Contact Switches (Double Throw, Center Off), 20A at 277V

	Toggle Type		Lock Type	
Make	1-Pole	2-Pole	1-Pole	2-Pole
Hubbell	#1385	#1386-L	#1385-L	#1226-L

7. Ground Fault Circuit Interrupter (GFCI)
Hubbell GFST15I, or GFST20I

8. Pilot lights used in conjunction with circuit switches shall be neon type with red jewel, P & S #437 (120 volt) or #438 (277 volt) or approved equal.

2.04 DIMMER SWITCHES

- A. Dimmer switches shall be as indicated herein unless specifically noted otherwise on the drawings.
- B. Dimmer cover plate shall be the same color as switch cover plates in the same area.
- C. Dimmer switches shall be self-cooling and shall not require forced air cooling when individually or gang mounted. All dimmers shall be by the same manufacturer and the same appearance.
- D. Dimmers shall include "RF" filters and is voltage stabilized.
- E. Incandescent dimmers shall be used for control of line voltage incandescent light fixtures except "low voltage" type lights. Lutron "Centurion" series.
 1. Dimmer wattage shall be rated 2000 watt unless noted otherwise on the drawings.
- F. Fluorescent dimmers, voltages as indicated on the drawings.
 1. Fluorescent dimmers (individual dimmers controlling less than 24 lamps per dimmer) Lutron "Nova" series.
 2. Fluorescent dimmers (more than 24 lamps)
 - a. Lutron #FDA-40 up to 40 lamps per controller.
 - b. Lutron #FDA-80 up to 80 lamps per controller.
 - c. Provide a minimum of 3-20 amp on all 120 volt units and on 277V 80 amp units.
 - d. Control stations Lutron "Nova" series.
 - e. Provide all material and labor for a complete and operable system.

- G. Low voltage (transformer type) incandescent light dimmers shall be specifically designed for dimming low voltage light fixture transformers. Lutron "Nova".

2.05 RECEPTACLES

- A. All receptacles in flush type outlet boxes shall be installed with a bonding jumper to connect the box to the receptacle ground terminal. Grounding through the receptacle mounting straps is not acceptable. The bonding jumper shall be sized in accordance with the branch circuit protective device as tabulated herein under "Grounding". Bonding jumper shall be attached at each outlet to the back of the box using drilled and tapped holes and washer head screws 6-32 or larger (except isolated ground receptacles). For receptacles in surface mounted outlet boxes direct metal-to-metal contact between receptacle mounting strap (if it is connected to the grounding contacts) and outlet box may be used. Color as selected by OWNER'S REPRESENTATIVE. Receptacles connected to emergency power circuits shall be red.
- B. Duplex convenience receptacles shall be grounding type, 120 volt, 15 ampere, and shall have two current carrying contacts and one grounding contact which is internally connected to the frame. Outlet shall accommodate standard parallel blade cap and shall be side wired:
 - 1. Hubbell, Specification Grade Commercial Series, Ivory, or equal.
- C. Isolated ground receptacles
 - 1. The receptacle insulation barrier shall isolate the receptacle ground contact system from ground. Connect the ground plug contact to a separate dedicated insulated ground bonding conductor. The receptacle ground plug contact shall not be grounded to the raceway or outlet box. Duplex convenience receptacle 20 amp minimum, with two current carrying contacts and one grounding contact, or as noted on the drawings.
 - 2. Identify receptacle with an orange triangle on the receptacle face and orange receptacle body. Red body for receptacles connected to emergency power.
 - a. Hubbell, Specification Grade Commercial Series, Ivory, or equal.
- D. Weatherproof receptacle: Ground fault type duplex receptacle, mounted in a flush hinged door enclosure with lock and key. Enclosure shall be a P & S #4600 with a #1591F46 receptacle. On exposed conduit runs, weatherproof ground fault type receptacle as hereinbefore specified, installed in "FS" conduit with one of the following spring door type covers:
 - 1. Hubbell, Specification Grade Commercial Series, or equal.
- E. Special outlets shall be as indicated on the drawings.

2.06 PLATES

Provide plates for every switch, receptacle, telephone, computer, television and other device outlets. All plates shall be 0.040" stainless steel, Type 302 alloy composed of 18% chromium and 8% nickel. Plates shall be manufactured by P & S, Hubbell, Leviton or General Electric only.

2.07 VANDALPROOF FASTENINGS

Provide approved vandalproof type screws, bolts, nuts where exposed to sight throughout the project. Screws for such items as switch plates, receptacle plates, fixtures, communications equipment, fire alarm, blank covers, wall and ceiling plates to be spanner head stainless steel, tamperproof type. Provide OWNER with six (6) screwdrivers for this type.

2.08 STRUCTURAL AND MISCELLANEOUS STEEL

Structural and miscellaneous steel used in connection with electrical work and located out-of-doors or in damp locations, to be hot-dip galvanized unless otherwise specified. Included are underground pull box covers and similar electrical items. Galvanizing averages 2.0 ounce per square foot and conforms to ASTM A123.

2.09 FLASHING ASSEMBLIES

Provide Semco Fig. #1100-4 lead flashing assemblies at all roof penetrations. Seal the joint between flashing and pipe with waterproofing compound.

2.10 RELAYS, CONTACTORS, AND TIMESWITCHES

A. Individual Control Relays (HV/AC Plumbing of the Control Functions)

1. Individual control relays shall have convertible contacts rated a minimum of 10 amperes, 600 volts regardless of usage voltage. Coil voltage, number and type of contacts shall be verified and supplied to suit the specific usage as shown in the wiring diagrams and/or schedules on the electrical and mechanical drawings. Coil control circuit shall be independently fused, sized to protect coil. Relays shall be installed on prefabricated mounting strips. Each relay shall have a surge suppressor to limit coil transient voltages. Furnished in the NEMA Type I enclosure unless indicated otherwise.
2. The following relays are approved:

<u>Manufacturer</u>	IYQg
Arrow Hart	IMP
General Electric	Class CR 2811
I.T.E.	Class J10
Square D Co.	Class 8501, Type A
Westinghouse	Bul. 16-321, Type NH
Allen Bradley	Approved Equal

B. Contactors and/or Relays

1. Contactors and/or relays for control of lighting shall be 600 volt A.C., electrically operated, mechanically held units, open type for panel mounting with number of poles and of size as indicated on the drawings. Provide auxiliary control relay for operation of each contactor and/or relay with a two-wire control circuit.
2. Contactors and/or relays shall be mounted in panelboards in barriered section under separate hinged lockable doors or in contactor and/or relay cabinets as called for on the drawings. Contactors and/or relays shall be installed on Lord sound absorbing rubber mounts.
3. Contactors and/or relays shall be Automatic Switch Co. Bulletin #920 Series for 2 and 3 pole, Automatic Switch Co. Bulletin 917 Series with poles as indicated on drawings. Coil control circuit shall be independently fused, sized to protect coil.
4. Contactors and/or relays shall be equipped with a switch, in the proper configuration, to disconnect the control circuit controlling the coil of the respective device. Control circuit disconnect switch shall be labeled showing function of device.

C. Timeswitches

1. All timeswitches shall have synchronous motor drive for operation on 120 or 277 volts, 60 Hertz, A.C. and shall be furnished with a ten-hour, spring-driven, reserve-power motor. Contacts shall be rated 40A per pole.
 - a. Exterior lighting timeswitches for control of individual circuits or electrically operated relays shall have astronomic dial and shall be Tork 7000ZL Series or approved equal by Paragon or Intermatic.
 - b. Interior lighting timeswitches for control of individual circuits or electrically operated relays shall be Tork 7000 Series or approved equal by Paragon or Intermatic.

- c. Timeswitches for control of air conditioning or plumbing equipment shall have seven day dial and shall be Tork WL Series or approved equal by Paragon or Intermatic.
2. All timeswitches shall be mounted in separate section in top of panelboards under separate lockable door unless otherwise indicated on drawings. Clear opening for timeswitch shall be a minimum of 12" x 12".

D. Contactors and/or Relays/Timeswitch Cabinet

1. Contactors, relays, and/or timeswitches not indicated to be mounted in electrical panels shall be mounted in a cabinet, size as required, with hinged lockable door keyed same as panelboards. Construction of cabinet shall be similar to terminal cabinets.
2. Each contactor, relay or timeswitch mounted in the contactor cabinet shall be barriered in its own compartment, and shall be installed on Lord sound absorbing mounts.
3. Contactor cabinets shall be of the same manufacturer as the panelboards.
4. Where relays and/or contactors occupy the same enclosure as timeswitches they shall have a clear acrylic shield installed over each relay or contactor to guard line exposed parts from accidental contact by nonauthorized personnel.

2.11 DISCONNECTS (SAFETY SWITCHES)

Disconnect switches shall be rated 600 volt A.C., NEMA Type HD, quick-make, quick-break, h.p. rated, fused Class "R", in NEMA Type I enclosure, lockable with number of poles and amperage as indicated on the drawings. Provide neutral bus and conductor landing lugs, size to match conductors shown on drawings. Where enclosure is indicated W.P. (weatherproof) switches shall be raintight NEMA Type 3R enclosure, lockable. Maximum voltage, current and horsepower rating clearly marked on the switch enclosure and switches having dual element fuses shall have rating indicated on the nameplate.

2.12 TRANSIENT VOLTAGE SURGE PROTECTOR (TVSS)

A. General

1. The unit shall be modular in construction and operate in parallel with 60 H.Z. A.C. line voltage, four (4) wire or five (5) wire, grounded or ungrounded systems, as applicable; voltage, KVA and ampere capacity as indicated on the drawings. Suitable for connection through a external circuit breaker or combination switch/fuse protective device rated 30 ampere, continuous duty, rated for Service Entrance equipment connection.
2. The unit shall operate correctly with any combination of resistive, inductive, or capacitive loads. The unit shall automatically shunt to ground the electrical transients and EMI/RFI noise occurring above the specified values. The unit shall automatically reset after transient condition has passed. Operating temperature - 40° centigrade to 85° centigrade.
3. Provide one or more individual self-contained protection module(s) for each line voltage phase, plug-in type. Provide one spare individual plug-in protection module. Provide incoming line, neutral and ground conductor termination lugs rated CU/AL #14 thru #4 AWG. Lugs shall be barriered from and prewired to the respective protection modules.
4. Provide a NEMA 12 housing to contain all unit modules, devices and conductor terminations. The housing shall include a hinged padlockable door. Surface mounted, with conduit entrance knockouts. Maximum housing size shall not exceed 36" wide x 72" high x 8" deep.
5. As manufactured by EFI Corporation Model #MXPB/TVSS; MCG Electronics; Current Technology; Liebert or equal.

B. Operational Characteristics

1. Transient voltage protection, testing, listing and certification.
 - a. UL 1449 (latest edition) and CSA, for Transient Voltage Surge Suppressor, UL 1283 for transient voltage electrical noise attenuation, ANSI/IEEE C62.45, C62.1 for C62.41, (latest edition) transient clamping voltages for both Normal Mode and Common Modes against Category A & B ring wave and Category B impulse wave.

- b. The unit connected to the service entrance shall also withstand a minimum of 1000 sequential ANSI/IEEE C62.41 Category C surges without failure following IEEE test procedures in C62.1, C62.41 and C62.45.
- 2. Transient voltage protection, EMI noise rejection, and RFI noise rejection shall be provided for Common Mode (line-to-neutral), Normal Mode (line-to-line) and neutral to ground.
- 3. EMI and RFI noise rejection.
Conducted line noises interference both electromagnetic (EMI) and radio frequency (RFI) shall be reduced by the unit over a continuous spectrum of 0.5 MHZ to 1.0 MHZ. The basis for reduction shall be a standardized 50-0HM insertion loss MIL -STD-220A test. Provide spectrum analysis test dB attenuation reports showing RFI filtering over specified frequencies. Test data based on calculated or computer simulation is not acceptable.
- 4. Three phase and grounded "WYE" performance requirements.

Characteristics	208/120 Volt	480/277 Volt
a. Nominal line to line	208 Volt	480 Volt
b. Nominal line to neutral	120 Volt	277 Volt
c. Internal capacitance (Microfarads)	2.5	2.5
d. Maximum response time	1-nanosecond	1-nanosecond
e. EMI/RFI noise rejection	25-35DB	25-35DB
f. Nominal peak clamp voltage line to neutral		
and line to ground	205 Volts	330 Volts
g. Minimum transient energy dissipation per phase		
(at 8 x 20 microseconds (waveform))	1000 Joules	1500 Joules
h. Peak transient withstand (at 8 X 20 microseconds waveform)		
without failure of the unit	50000 Amp	60000 Amp
1.Category-C3	80,000Amp	100,000Amp
2.Category-B3	60,000Amp	80,000Amp
3.Category-A3	50,000Amp	60,000Amp

C. Diagnostic indicators

- 1. Shall display the "Normal" and "Fault" status of each line suppression circuit, along with protection circuit "on" indication.
- 2. Shall provide a sonic audible fault alarm with silence push-button.

D. Surge Suppressor Protection Categories

- 1. Surge protectors shall comply with ANSI C62.41 (Latest Revision) Standard Protection Categories for "impulse" and "ringwave" transients, based on the installation locations shown in the contract documents.
 - a. Service entrance, main switchboard or substation locations - Category "C3", high exposure.
 - b. Mid building, distribution panels, distribution panels over 400 ampere main bus rating locations- Category "B3", high exposure.
 - c. Branch circuit panelboards 400 ampere or less main bus rating - Category "A3", high exposure.
- 2. The TVSS short circuit current withstand rating shall exceed the actual short circuit current available at the TVSS installation location

2.13 WIREWAY

A.

General

al

Unobstructed lay in type, metal wireway, fittings and connectors U.L. listed for use as wireway and auxiliary gutter. Length, elbows and "T-S" as shown on drawings. Minimum cross-section size 4 inches X 4 inches, but not less than shown on the drawings. Suitable for mounting in any position orientation.

B. Construction

1. Minimum metal gauge shall not be less than 14 gage.
2. Cover shall be hinged entire length of cover. Cover shall be held in the closed position with bolts and nuts.
3. Provide spring nuts on all hardware fastener penetrations into the interior of the wireway to protect against wire insulation damage.
4. The inside of 90-degree corners in the wireway shall be a 45-degree bevel.
5. Grounding continuity between wireway sections and fittings shall be continuous the entire length of the wireway.

C. Finish

1. Indoor non-raintight, rust inhibitor phosphatizing base coating and baked enamel finish, manufacturer's standard color.
2. Raintight or outdoor-galvanized metal, with corrosion resistant phosphate primer and baked enamel finish, manufacturer's standard color, Nema 3R construction.
3. All hardware shall be plated to prevent

corrosion. PART 3 EXECUTION

3.01 GROUNDING (ADDITIONAL REQUIREMENTS)

- A. Grounding shall be executed in accordance with all applicable codes and regulations, both of the State of California, and local authorities having jurisdiction, and in compliance with DSA.
- B. Each pull box or any other enclosure in which several ground wires are terminated shall be equipped with a ground bus secured to the interior of the enclosure. The bus shall have a separate lug for each ground conductor. No more than one conductor shall be installed per lug.
- C. The maximum resistance to ground shall not exceed 5 ohms.

3.02 OUTLET AND JUNCTION BOXES

- A. Accurately place boxes and securely fastens to structural members. Where outlets are shown at same location but at different mounting heights, install outlets in one vertical line. Where outlets are shown at same location and mounting height, mount outlets as close together in a horizontal row as possible. Where the outlet boxes for switches and receptacles are shown at the same location and mounting height, mount in common outlet box with barriers between devices. Provide single piece multigang cover plate for close mounted outlet boxes. Where switches are shown on wall adjacent to hinge side of doors, box shall be installed to clear door when door is fully opened.
- B. Flush mounted boxes shall be attached to two studs or structure members by means of metal supports.
- C. Boxes above accessible ceilings shall be attached to structural members. Where boxes are suspended, they shall be supported independently of conduit system by means of hanger rods and/or preformed steel channels. Boxes shall be supported independently of all piping, ductwork, equipment, ceiling hanger wires and suspended ceiling grid system.
- D. Surface mounted outlets shall be attached to concrete or masonry walls by means of expansion shields.
- E. Floor boxes shall be installed level with finish floor and within adjustable limits of floor ring.

Where outlets are shown at same or adjacent location, use multigang boxes

- F. Outlet Box Horizontal and Vertical Separation: Outlet boxes and device outlet rings installed flush in walls shall be horizontally and vertically separated by not less than 24 inches (edge of box to edge of box) from device outlet boxes and rings in common wall surfaces located on the opposite (back) side of the same wall.
 - 1. Where the separation cannot be maintained, provide a solid backing behind and completely enclosing each outlet box.
 - 2. The backing shall extend the width of the wall cavity (i.e. between "studs" or masonry cells) behind the box and 12 inches above and below the outlet box centerline, completely enclosing the outlet box.
 - 3. The backing shall consist of the following:
 - a. 5/8 inch thick gypsum board anchored in place for "stud" wall construction.
 - b. Solid "mortar" to completely fill the outlet box "cell" behind the box in masonry construction.
- G. In fire rated walls and ceilings provide fire rated "box-wrap" around the outside of each outlet box placed in fire rated wall or ceiling inside the wall, to maintain the fire rating of wall with the installed outlet boxes.
- H. Plug-in type receptacle installation orientation:
 - 1. The "ground-pin" shall face "up" at the receptacle top location (double duplex) 4-plex, individual and vertically mounted individual duplex receptacles.
 - 2. The "neutral-blade" shall face "up" at the receptacle top location on horizontally mounted duplex receptacles.

3.03 DIMMER SWITCHES

- A. Do not break off dimmer cooling fins.
- B. Large dimmers shall be surface wall mounted at the location indicated on the drawings.

3.04 TRANSIENT SURGE PROTECTOR INSTALLATION

- (TVSS) A. Installation
 - 1. Install unit cabinet to insure a maximum connected circuit length of less than 8 feet from the equipment the transient surge unit is connected to, approximately +48" on wall.
 - 2. Install TVSS inside switchgear, switchboards, panelboards, etc. where shown on the drawings.
 - 3. Connect between transient surge unit and supply equipment with not less than 1 1/4" conduit containing 5#4 AWG, copper conductor, 600 volt THHN/THWN insulation, connection circuit.
- B. Install, connect and test unit in accordance with manufacturer's recommendations.
- C. Connect transient surge unit to main building ground bus with 1 1/4"C - 1#2 AWG copper conductor 600 volt, THHN/THWN insulation.
- D. Provide a subfeed overcurrent protective device in the respective panel or switchboard to supply the TVSS connection circuit, whether or not shown on the drawings. The protective subfeed device shall be a thermal magnetic circuit breaker rated not less than 30 ampere - 3 pole or a safety switch and fuse unit rated not less than 60 ampere - 3 pole, voltage and short circuit interrupting class to match the respective circuit voltage.

3.06 WIREWAY INSTALLATION

Wireway hangers shall provide clamp type, hanger rod type, direct bolted bracket type from ceiling or walls as indicated on the drawings and required for field installation locations. Supports shall be installed a minimum of 5 ft. on center.

END OF SECTION

SECTION 26 05 30
CONDUIT AND WIRE

PART 1 - GENERAL

1.01 SCOPE

- A. Work Included: All labor, materials, appliances, tools, equipment, facilities, transportation and services necessary for and incidental to performing all operations in connection with furnishing, delivery and installation of the work of this Section, complete as shown on the drawings and/or specified herein. Work includes, but is not necessarily limited to the following:
1. Examine all other sections for work related to those other sections and required to be included as work under this section.
 2. General provisions and requirements for electrical work.

1.02 SUBMITTALS (ADDITIONAL REQUIREMENTS)

- A. Submit product data sheets for all wire, supports, conduit, fittings and splicing materials.
- B. Submit material list for all conduit and conduit fittings.
- C. Submit details and structural engineering calculations for conduit support systems.

PART 2 - PRODUCTS

2.01 CONDUIT

- A. General
1. The interior surfaces of conduits and fittings shall be continuous and smooth, with a constant interior diameter. Conduits and conduit fittings shall provide conductor raceways of fully enclosed circular cross section. The interior surfaces of conduits and fittings shall be without ridges, burrs irregularities or obstructions. Conduits and fittings of the same type shall be of the same uniform weight and thickness.
 2. Type of conduit, type of conduit fittings and conduit supports shall be suitable for the conditions of use and the conditions of location of installation, based on the manufacturer's recommendations and based on applicable codes.
 3. All fittings for metal conduit shall be suitable for use as a grounding means, pursuant to the applicable code requirements. All metal conduit and metal conduit fittings shall provide 3 second duration ground fault current carrying ratings, when installed and connected to the respective conduit, as follows:
 - a. RMC and EMT conduit fittings.
 - 1) 0.75 inch through 1.5 inch conduit/fitting size - 10,000 ampere RMS.
 - 2) 2.0 inch and larger conduit/fitting size - 20,000 ampere RMS.
 - b. FMC and LTFMC Conduit Fittings
 - 1) 0.75 inch through 1.25-inch conduit/fitting size-1,000 ampere RMS (without external bonding jumper).
 - 2) 1.5 inch through 4.0-inch fitting size-10,000 ampere RMS with bonding jumper.
 4. Protective corrosion resistant finish for metal conduit fabricated from steel and metal conduit fittings fabricated from steel, shall be as follows:
 - a. Clean all metal surfaces (including metal threads) with acid bath "pickle" prior to coating, to remove dirt, oil and prepare surfaces for galvanizing.
 - b. Hot-dip galvanized zinc coating on all interior and exterior steel surfaces. Minimum finish zinc coating thickness shall not be less than 0.002 inches.
 - c. Threads shall be hot-dip zinc coated after machine fabrication.
 - d. Exterior metal surfaces shall be finished with clear organic polymer topcoat layer, after galvanizing.

- e. The inner metal surfaces of conduit fittings shall be finished with a lubricating topcoat after galvanizing, to facilitate conductor pulling through the conduit/fitting.
 5. Threads for metal conduit and metal conduit fittings shall be taper-pipe-thread, National Pipe Standards (NPS) and shall comply with ANSI-B1.20.1.
 6. Metal conduit termination connector fittings shall be provided with a manufacturer installed, insulating throat bushing inside the fitting. The bushing shall protect the wire conductor insulation from cutting, nicks and abrasion during conductor installation and electrical load "cycling" after installation is complete. The bushing shall comply with UL 94V-0 flammability.
 7. Provide conduit bonding/grounding jumper from metal enclosures with "concentric ring" knockouts, to positively ground/bond each respective conduit(s) to the metal enclosure.
 8. Metal conduit fittings connecting to PVC coated metal conduit shall be PVC coated to match the conduit.
 9. The conduit and fittings shall be watertight and airtight without cracks and pinholes.
- B. Rigid Metal Conduit (RMC)
1. Rigid metal, round tubing, machine threaded at both ends.
 - a. The conduit and conduit fittings shall comply with the requirements for an equipment grounding conductor, pursuant to applicable codes.
 2. RMC raceway types shall be as follows:
 - a. Rigid galvanized steel conduit (RGS), minimum yield strength shall be 35,000 PSI. Shall comply with NEMA standard 5-19 (latest revision); ANSI C80.1 and ANSI-C80.4 (latest revision); UL 514-B and UL 6 (latest revisions); National Pipe Standard Specification (latest revision).
 - b. Intermediate steel conduit (IMC). Shall comply with NEMA Standard 5-19 (latest revision) ANSI-C80.6 (latest revision); UL 2142 (latest revision).
 3. RMC fittings:
 - a. Fittings shall be compatible with RGS and IMC.
 - b. Fittings shall be rated "liquid tight".
 - c. Fittings imbedded in concrete shall be rated "liquid tight" and "concrete tight".
 - d. Connectors and couplings for terminating, connecting and coupling to RMC conduit shall be threaded metal.
 - e. Fittings shall comply with ANSI C80.4 and ANSI C33-84 (latest revision); NEMA FB1 (latest revision); UL 514 (latest revision).
 - f. Conduit seal fittings:
 - 1) Conduit seals shall prevent the passage of gasses, liquids and vapors past the location of the seal installation in the conduit.
 - 2) Conduit seals shall be suitable for installation in both vertical and horizontal conduit locations.
 - 3) Conduit seals shall be visible and accessible for inspection after installation is complete.
 - 4) Conduit seals shall be rated for the following locations:
 - a) Wet locations
 - b) Classified hazardous location materials NEC Class 1 Division 1.
 - c) Temperature ranges from 0 [minus 20] degrees centigrade through 90 degrees centigrade.
 - 5) Conduit seals, sealing compound and sealing compound dam shall be the products of the same manufacturer.
 4. RMC fittings as manufactured by:
 - a. For threaded enclosure, termination connection.
 - 1) Thomas & Betts - 106 Series bonding locknut, 5302 series sealing ring with stainless steel retainer.
 - b. For non-threaded enclosure, termination connector.

- 1) Thomas & Betts - 370 Series watertight threaded sealing hub, 106 series threaded bonding lock nut, Sta-Con Series enclosure bonding jumper and 3870 Series threaded ground bushing.
 - 2) Emerson-OZ/Gedney-CHMT/CHT watertight threaded hub with bonding locknut and GH50G Series enclosure bonding jumper.
 - c. For RMC to RMC conduit-to-conduit coupling
 - 1) Thomas & Betts/Erickson - 674 (threaded) Series
 - 2) Emerson-OZ/Gedney Type TPC (threaded) Series
 - 3) Threaded RMC conduit couplings, product of the same manufacturer as the RMC conduit.
 - d. For RMC Conduit Seals
 - 1) Emerson-OZ/Gedney-EYA and EYAM (threaded) Series
 - 2) Appleton-EYF and EYM (threaded) Series
- C. Electrical Metallic Tubing (EMT)
1. Rigid metal round tubing, "thin wall" steel construction, with non-threaded ends.
 - a. The conduit and conduit fittings shall comply with the requirements for an equipment grounding conductor pursuant to applicable codes.
 - b. The conduit shall be watertight and airtight without cracks and pinholes.
 2. EMT shall be allowed for conduit size ranges from 0.75-inch through 2.0-inch. EMT is not allowed for exterior locations, including under covered walks, shelters, or roof overhangs. EMT is not allowed less than ten (10) feet above FF, not in concrete, not underground, and not in runs longer than 100'.
 3. Comply with ANSI C80.3, C80.4, and ANSI C33.98 (latest revisions); UL 594 and UL 797 (latest revisions); CEC Section 12500 (latest revision).
 4. EMT fittings:
 - a. Connectors and couplings for terminating, connecting and coupling to EMT conduit shall be non-threaded steel fabrication.
 - b. EMT termination connector fittings shall be as follows:
 - 1) Set screw type "concrete tight" when installed in dry interior locations.
 - 2) Compression types "raintight" and "concrete tight" when installed in wet or damp locations, outdoors and in concrete or masonry construction.
 - c. Fittings shall comply with ANSI C33.84 (latest revision); UL 514 (latest revision); NEMA FB-1.
 5. EMT fittings as manufactured by:
 - a. For threaded and non threaded enclosure, termination connector
 - 1) Thomas & Betts-TC721A (set screw type) Series (with locknuts).
 - 2) Emerson-OZ/Gedney-TC500I (set screw type) Series (with locknuts).
 - 3) Thomas & Betts-5123 (compression type) Series (with 2 locknuts).
 - 4) Emerson-OZ/Gedney-TC600I (compression type) Series (with locknut).
 - 5) Thomas & Betts-4240 (compression type) Series (90 degree angle with locknut).
 - 6) Emerson-OZ/Gedney-TWL (compression type) Series (90 degree angle with locknut).
 - b. For EMT to EMT conduit-to-conduit coupling:
 - 1) Thomas & Betts-TK121A (set screw type) Series (with locknut).
 - 2) Emerson-OZ/Gedney-5000 (set screw type) Series (with locknut).
 - 3) Thomas & Betts-5120 (compression type) Series.
 - 4) Emerson-OZ/Gedney-TC600 (compression type) Series.
 - c. For EMT to RMC conduit to conduit combination coupling:
 - 1) Thomas & Betts-HT221 (set screw type) Series.
 - 2) Emerson-OZ/Gedney-ESR (set screw type) Series.
 - 3) Thomas & Betts-530 (compression type) Series.
 - 4) Emerson-OZ/Gedney-ETR (compression type) Series.
- D. Flexible Metal Conduit (FMC)
1. Round flexible conduit, fabricated from a single continuous steel strip. The steel shall be factory formed into continuous interlocking convolutions to form a complete lock between

steel strips and provide raceway flexibility.

2. Metal to metal grounding contact shall be maintained throughout the length of the FMC conduit.
 3. FMC shall be used only for making motor connections, conduit drop from remote junction boxes to fixtures installed above the suspended ceiling, and as specifically noted on the drawings. FMC shall not be used for runs longer than 8 feet; at any exposed locations; for any conduit size larger than 1-1/4".
 4. FMC shall comply with ANSI-C.33.84 and ANSI C33.92; NEMA FB-1; CEC 12-1100.
 5. FMC Fittings
 - a. FMC fittings shall be malleable iron construction or steel construction.
 - b. Fitting shall automatically cause the FMC raceway throat opening to be centered with respect to the fitting throat opening.
 - c. Straight and angled connector termination fittings shall be threaded on one end and shall include a threaded locknut, suitable for connection to threaded and unthreaded enclosures.
 - d. The attachment of the fittings to FMC shall be angled saddle type, to engage and interlock with the FMC spiral groove, and shall be unaffected by vibration. Direct bearing screw type fittings shall not be used.
 - e. Direct FMC conduit-to-FMC conduit coupling of FMC shall not be permitted.
 - f. Shall comply with ANSI C33.9, and ANSI C33.92 (latest revision); NEMA FB1 (latest revision); U.L. 514.
 6. FMC fittings as manufactured by:

a. Straight Termination Connectors	45 & 90 Degree Angle Connectors
1) Thomas & Betts-3110 Series	Thomas & Betts-3130 Series
(with locknut)	(with locknut)

 - b. FMC to EMT conduit combination coupling:
 - 1) Thomas & Betts 503TB Series.
- E. Liquid Tight Flexible Metal Conduit (LTFMC)
1. The metal conduit core of LTFMC shall comply with the same requirements as FMC conduit, with the addition of a thermoplastic exterior flexible jacket over the metal core.
 2. The exterior jacket shall be positively locked to the metal core to prevent jacket "sleeving".
 3. The LTFMC shall be rated for installation and operating service temperatures of between minus 20 degrees centigrade through plus 90 degrees centigrade.
 4. The LTFMC jacket shall be suitable for continuous exposure to sunlight, rainwater, water vapor, mineral oils and liquid solvents, without penetrating into the conduit and without deteriorating the jacket.
 5. LTFMC sizes from 0.75-inch through 1.25-inches shall include an additional internal ground conductor, fabricated by the manufacturer, as an integral part of the conduit core.
 6. Direct LTFMC conduit-to-LTFMC conduit coupling of LTFMC shall not be permitted.
 7. LTFMC shall be allowed for conduit size ranges from 0.75-inch through 4.0-inches.
 8. In addition to the requirements for FMC conduit, LTFMC shall also comply with ANSI C-33.84 (latest revision); NEMA-FB1 (latest revision); CEC 12-1400 (latest revision).
 9. LTFMC fittings
 - a. Fittings shall include an external mechanical ground/bond wire connector.
 - b. The attachment of the fitting to LTFMC shall be threaded compression type onto the conduit core with locknut and liquid tight jacket compression seal. The fitting shall automatically prevent "sleeving" of the jacket.
 - c. Straight and angled termination connector fittings shall be threaded on one end and shall include locknut suitable for connection to threaded and unthreaded enclosures.
 10. LTFMC fittings as manufactured by:

a. Termination connector fittings:	
<u>Straight</u>	<u>45 and 90 Degree Angle Connectors</u>
1) Thomas & Betts-5331 GR Series.	Thomas & Betts-5341GR and 5351GR Series.
2) Appleton-STB Series; STN-L Series for use with preformed "knockouts".	Appleton-STB-L Series; STN-L Series for use with preformed "knockouts".

3) Emerson- OZ/Gedney-4QSeries. Emerson-OZ/Gedney-4Q Series

- b. LTFMC to RMC conduit to conduit combination coupling fittings:
 - 1) Thomas & Betts-5271 GR Series.
 - 2) Emerson-OZ/Gedney-4Q Series

F. Rigid Non Metallic Conduit (RNMC)

- 1. General
 - a. Conduit and fittings shall be 90 degree centigrade conductor rated. Fabricated from homogeneous material, free from visible cracks, holes or foreign inclusions, with integral "end-bell". The conduit and conduit fittings shall be watertight and airtight.
 - b. Conduit, conduit fittings and conduit fitting assembly "solvent cement" shall all be the product of the same manufacturer. Conduit fittings shall be solvent cement welded watertight.
 - c. Conduit and fittings shall be identified with legible markings showing ratings, size and manufacturers name.
 - d. RNMC and fitting shall be corrosion resistant, watertight.
 - e. Conduit shall be suitable for conductor operating temperatures from minus 20 degrees centigrade to 90 degrees centigrade.
 - f. RNMC shall comply with NEMA TC-2 (PVC 40 conduit, latest revision) NEMA TC-6 (EB conduit latest revision) and NEMA TC-3 (fittings, latest revision); UL 514 and UL 651 (latest revision).
- 2. Polyvinyl Chloride (PVC)-RNMC
 - a. PVC-schedule 40 heavy wall construction.
 - b. PVC-schedule 80 extra heavy wall construction.
 - c. PVC-type EB.
- 3. RNMC fittings connecting to metallic raceways shall be provided with a ground/bond jumper connection.

G. Combi-Duct

- 1. Rigid nonmetallic conduit combining an continuous linear outer raceway (duct) with factory installed (inside the outer duct) multiple, segregated inner raceway (ducts). Rigid, schedule 40 PVC construction. Shall be modular lengths of 20-feet for each duct segment.
- 2. The conduit shall be suitable for use with signal/ telecommunications, fiber optic, telephone and computer/data circuits, operating at 100 volts or less, UL listed and labeled.
- 3. Outer Duct, outer enclosing Schedule-40 PVC duct size. The outer enclosing duct shall be 4.2-inches inside nominal duct diameter and 4.5-inches outer duct nominal diameter.
- 4. Inner-ducts (Contained inside the enclosing outer duct), non-metallic SDR-19 or Type-C/CAO-8546:
 - Triple Combi-Duct
 - a. Quantity of three (3) continuous round rigid inner linear ducts, nominal size inside diameter 1.5-inches for each inner duct.
 - Quad Combi-Duct
 - b. Quantity of four (4) continuous round rigid inner linear ducts, nominal size inside diameter 1.19-inches for each inner duct.
- 5. Manufacturer's standard bends and offsets, minimum 72-inches radius.
- 6. Combi-duct and combi-duct fittings shall be airtight and watertight. Approved for direct burial in earth and approved for encasement in concrete.
- 7. As manufactured by Carlon # Multi-Guard/Multi-Cell Series; American Pipe and Plastic (AMTEL) #Multi-Bore series; or equal.

H. Expansion Joint, Deflection Joint and Seismic Joint Conduit Fittings

- 1. Expansion Conduit Fitting - Fitting shall provide for a minimum of 2-inches straight line movement between two connecting conduits in each direction (total 4-inches conduit expansion and contraction) parallel to the respective conduit lengths. Fitting shall be watertight.

2. Deflection Conduit Fitting - Fitting shall provide for a minimum of 30 degrees angular deflection movement ("Shear" deflection) between two connecting conduits, in any direction perpendicular to the length of the respective conduits. Fitting shall be watertight.
 3. Combination Expansion/Deflection Conduit Fitting - Fitting shall provide the combined "expansion" and "deflection" movement capacity between two connecting conduits as described for separate "expansion" and "Deflection" conduit fittings. Fitting shall be approved for installation concealed in both masonry/ concrete construction and exposed non-masonry/concrete construction. Fitting shall be watertight.
 4. Fittings shall comply with UL.
 5. Fittings as manufactured by:
 - a. Conduit expansion fittings exposed or concealed locations as manufactured by:
 - 1) Emerson-OZ/Gedney – AXB-8 Series for RMC conduit.
 - 2) Emerson-OZ/Gedney - TX Series for EMT conduit.
 - 3) Appleton – AXB or XJ8 Series for RMC conduit and EMT conduits. Provide RMC to EMT combination conduit coupling fittings for each end of the expansion fitting.
 - b. Combination expansion/deflection conduit fittings exposed or concealed conduit locations as manufactured by:
 - 1) Emerson-OZ/Gedney - AXDX Series for RMC conduit.
 - 2) Emerson-OZ/Gedney - AXDX Series for EMT conduit.
 - 3) Appleton-DX Series for RMC conduit.
 - 4) Provide RMC to EMT combination conduit coupling fittings for each end of the expansion/deflection fitting.
 - c. Conduit expansion/deflection fittings for FMC and LTFMC conduit.
 - 1) Provide a minimum of 12-inches of "slack" LTFMC in each FMC or LTFMC conduit at building and structure seismic or expansion joint conduit crossings.
 - 2) Note: Each FMC "slack" expansion/deflection location, shall be considered as not less than a 90 degree conduit bend location, for compliance with the maximum quantity of conduit bends allowed in a raceway.
 6. Conduit fitting bonding jumper:
 - a. The grounding/bonding path of metal conduit shall be maintained by the fitting.
 - b. Provide a bonding jumper at each expansion, deflection and combination expansion deflection conduit fitting.
 - c. The jumper shall be a bare flexible copper "braid". The copper braid electrical current carrying capacity shall be equal to the metal conduit.
 - d. Provide a factory terminated ground clamp on each end of the braid with adjusting steel conduit grounding clamps and connect to each respective conduit end.
 - e. The jumper braid length shall be 8-inches longer than the respective conduit fitting.
 - f. Bonding jumper for FMC and EMT fittings as manufactured by:
 - 1) Emerson-OZ/Gedney – BJ and BJE Series
 - 2) Appleton – BJ/XJ Series
- I. Conduit Bodies Conduit Fitting
1. Conduit bodies shall provide conductor access with a removable conduit body cover and wiring area enclosed in metal housing. The conduit body shall facilitate pulling conductors.
 2. In-line form "C" conduit bodies shall be prohibited.
 3. The interior space "length" of 90 degree "elbow" conduit bodies shall not be less than six (6) times the diameter size of the largest conduit connecting to the conduit body.
 4. Conduit body covers shall be removable, gasketed; watertight "domed" metal covers "Mogul-Type" with threaded screw attachment to the conduit body.
 5. Lubricated, reusable, wire roller guards inside the conduit body shall protect wire from insulation damage during wire "pulling".
 6. Conduit body fittings shall comply with UL 514.
 7. Conduit bodies as manufactured by:
 - a. For RMC Conduit
 - 1) Hubbell/Killark – LB/Mogul (90-degree elbow) Series – threaded body.

- 2) Emerson-OZ/Gedney - LB 6X/Mogul (90 degree elbow) Series - threaded body.
- 3) Appleton – NEC6X-LB/Mogul (90 degree elbow) Series - threaded body.
- b. For EMT Conduit
 - 1) Same as for RMC conduit. Provide EMT to RMC conduit combination coupling fitting for each outlet body connection.

2.02 PVC COATING

- A. PVC coatings shall be provided as described for specified metal products.
- B. PVC coating shall be factory applied, to comply with NEMA-RN1 and 5-19.
- C. The adhesion of the PVC coating to the coated metal shall exceed the strength of the coating itself, based on 0.5-inch “strip-pull” test.
- D. Uniform coating thickness shall be continuous without “breaks” or “pinholes” and shall not be less than the following:
 1. Exterior metal surfaces, 40-millimeter coating thickness.
 2. Interior metal surfaces, 10-millimeter PVC or urethane coating thickness (i.e. interior of conduits, interior of conduit fittings etc.).

2.03 CONDUIT SUPPORTS

- A. General
 1. Conduit Supports, hangers and fasteners for metal conduit shall be steel, hot dip zinc galvanized.
 2. Conduit supports, hangers and fasteners for PVC coated conduit shall be PVC coated to match the conduit PVC coating.
 3. Threaded hardware shall be continuous, free running threads.
 4. Conduit support systems, including support channels, pipe clamps, braces, anchors, hardware, fasteners, shall be sized to support the full capacity circuit conductors weight, plus the installed conduit weight, plus the conduit fitting weight and support hardware weight, plus a 300% additional weight capacity safety factor.
 5. Provide lock washer at each “bolted”/threaded connection.
 6. Conduit supports, fasteners, channels, braces, hardware, anchors, pipe clamps, and hangers as manufactured by Unistrut or Kindorf.
 7. Supports shall be free of “BURRS” and sharp edges.
 8. Metal supports cut in the field shall be zinc galvanized after cutting to prevent rust.
- B. Conduit Hangers
 1. Threaded steel hanger rods.
 - a. Hanger rods smaller than 0.375-inches in diameter shall not be used for support of individual conduits.
 - b. Hanger rods smaller than 0.5-inches in diameter shall not be used for support of multiple conduits.
 2. Conduit hanger wires shall be not less than 12-gauge steel.
 3. Conduit hangers shall attach to structure fasteners with steel “Clevis” or “Swing” hangers and shall provide a minimum of 45 degrees of angular movement in any direction at the point of the conduit hanger attachment to the structure fasteners.
 4. Conduits individually suspended by conduit hangers shall fasten to the respective hangers with “Clevis” type pipe hangers. The pipe hangers shall be steel, adjustable to fit conduit size and shall completely enclose the conduit circumference.
- C. Conduit Support Channels
 1. “C” channels shall be factory preformed with a minimum 12 gauge thickness metal. The channel shall be factory “punched” with regularly spaced slotted holes for fastener attachments along the length of the channel.

2. The "C" channel shall not deflect more than 0.1 inches between channel supports at maximum installed design load, including required safety factor.
3. Channels shall comply with ANSI-1008 (latest revision) and ASTM-A569 latest revision).
4. Channels shall provide "turned lips" at longitudinal edges to hold (lock-in) fasteners.
5. Conduit support channels suspended from conduit hangers shall attach to conduit hangers with treaded connections. Provide a minimum of two hangers (trapeze style) connected to each channel.
6. Non-suspended conduit support channels shall connect to structure fasteners with threaded connectors.

D. Fasteners, Seismic Earthquake Rated

1. Channel fasteners:
 - a. Channel fasteners shall "prelocate" and lock into the channel "turned lips" and channel "walls".
 - b. A separate metal strap shall "tie" each conduit to each channel with conduit channel fasteners.
2. Structure fasteners:
 - a. Structure fasteners for wall and floor mounted conduit attachments shall attach to existing masonry and concrete structures with structure fasteners using drilled, mechanical, expansion shield anchors.
 - b. Structure fasteners for wall and floor mounted conduit attachments shall attach to new masonry and concrete structures with structure fasteners using steel threaded inserts precast into the structures.
 - c. Structure fasteners shall center the support load above or below the beam flanges and reduce torsion-rotation forces exerted on the structural beam. Attach to steel structural members with "swing-beam clamps", with set-locking screw structure fasteners.
 - 1) Beam clamps shall include integral safety rod, strap or "J"-hook to secure the attachment clamp to the beam flanges on both sides of the beam, with integral hanger rod attachment.
 - 2) Or double-ended beam clamp to secure the attachment clamp to the beam flanges on both sides of the beam, with integral hanger rod attachment.
 - d. Structure fasteners for wall and floor mounted conduit attachments shall attach to wood structural members with flush "through-bolted" wood beam/wood framing stud structure fasteners.
 - e. Structure fasteners for wall mounted conduit attachments shall attach to steel framing studs and steel structural elements with spot welded steel structure fasteners or drilled and bolted structure fasteners.

E. Brace Connectors

1. Provide lateral brace connectors to resist horizontal, lateral and vertical movement of suspended conduits during seismic earthquakes.
2. The braces shall connect from each conduit support, attach as close to the conduit as possible, and attach to fixed rigid, nonsuspended building "main" structural elements with fixed anchoring.
3. Brace attachment connectors and fasteners shall be rigid preformed steel channels or flexible #10 gauge steel hanger wire.
4. Connect and attach the brace connectors to fixed structural elements in the same manner as conduit support hangers. The connection of braces to structural elements shall be independent of the conduit support hanger structure fasteners.

2.04 ELECTRICAL POWER WIRE AND CABLE

A. General

1. All wire and cable shall be single-conductor, annealed copper, insulated 600 volt, #12AWG minimum unless specifically noted otherwise on the drawings.

2. Conductors #10AWG and smaller shall be solid. Conductors #8AWG and larger shall be stranded.
3. Insulation of conductor connected to circuit protection devices required to be "100%" rated, shall be 90 degree centigrade rated insulation.
4. Insulation of conductors installed outdoors, on grade or underground, insulation shall be rated for wet locations.
5. Insulation of conductors installed outdoors, installed exposed to the sun, installed in exposed conduits, insulation shall be rated for high-temperature 90 degrees centigrade.
6. Insulation of branch circuit conductors installed in light fixtures, insulation shall be rated for 90 degrees centigrade.
7. Conductor exposed to oil, insulation and jacket shall be oil resistant, complying with "Oil Resistant-1" and "Oil Resistant-2" UL 83.

B. Conductor Insulation

1. 600 Volt AC and/or DC insulated conductors installed entirely inside conduits, or enclosed inside wireways, or enclosed inside raceways, insulation shall be rated as follows.
2. Indoor above Grade locations either concealed or exposed.
 - a. Dual rated THHN and THWN
 - b. Individually rated THHN-2
 - c. Individually rated THWN-2
 - d. XHHW-2
3. Outdoor above Grade either concealed or exposed.
 - a. XHHW-2
 - b. THWN-2
 - c. THW-2
4. Outdoor below Grade or outdoor on Grade.
 - a. XHHW-2
 - b. THWN-2
 - c. THW-2
5. All other enclosed raceway locations not described above.
 - a. XHHW-2
 - b. THWN-2
 - c. THW-2
6. Health Care facilities all circuits insulation shall be XHHW-2, rated Hospital-Grade.
7. 600 Volt AC and/or DC insulated conductors installed in open cable tray or open wireway or exposed insulation also shall be rated for exposed install locations.

C. Insulation Color Coding and Identification

1. The following color code for branch circuits:
 - a. Neutral . . . White (Tape feeder neutrals with white tape near connections)
 - b. Normal Power:

<u>120/208 Volt</u>	<u>480/277 Volt</u>	Ground
Green	Ground	Green
Phase A Black	Phase A	Brown
Phase B Red	Phase B	Orange
Phase C Blue	Phase C	Yellow
 - c. Isolated ground insulation shall be green with a longitudinal yellow stripe.
 - d. Emergency power same insulation color as normal power except as follows:

<u>120/208 Volt</u>	<u>480/277 Volt</u>
Provide a continuous stripe on each conductor insulation, orange or yellow, except ground	Provide a continuous stripe on each conductor insulation blue or black, except ground

2. When individual neutral conductors are shown for each branch circuit, the color code for the neutral conductors shall be as follows:
 - a. 120/208 volt; Phase A - White with Black stripe; Phase B - White with Red stripe; Phase C - White with Blue stripe.
 - b. 277/480 volt; Phase A - White with Brown stripe; Phase B - White with Orange stripe; Phase C - White with Yellow stripe.
 3. Feeders identified as to phase or leg in each, switchboard, switchgear, panelboard and junction location with printed identifying tape.
 4. Fire alarm conductors: Use 600-volt, type THHN-2/THWN-2 conductors and color-coded per equipment manufacturer's recommendations and approved and listed for use on fire alarm systems by the State Fire Marshal.
 5. Color coding for mechanical and plumbing control wiring shall be an agreed upon color code between the Mechanical/Plumbing CONTRACTOR and the Electrical CONTRACTOR, and color code shall be submitted to the DISTRICT'S REPRESENTATIVE in writing for approval prior to installation.
- D. Panel feeders shall be copper:
1. Wire size shown on the drawings is for copper conductors, unless specifically indicated otherwise.
 2. If the conductor termination is to be made on a bus bar or similar flat surface, a Burndy Type YA-A HYPLUG compression terminal intended for the specific conductor size, factory filled with oxide inhibitor compound shall be used. Terminal must be installed using a hydraulic compression tool equipment with a die head for the particular terminal used. Only Burndy Hypress tools shall be used for compression.
 3. If the conductor termination is to be made into a circuit breaker or similar insert compartment it shall be terminated by use of a Burndy AYP HYPLUG compression connector intended for the specific conductor size, factory filled with oxide inhibitor compound. Connector must be installed using only Burndy Hydraulic compression tool specifically approved for each respective connector.
 4. Connector aid shall be used for all terminations and connections. Connector aid shall be Burndy Pentrox A, NO-OX-1D Grade "A".
 5. When an aluminum lug is terminated to a copper bus with a steel or copper stud or bolt, place aluminum lug on stud or bolt followed by a flat steel washer, a Belleville washer, and steel or copper nut, in that order.

2.05 CHEMICAL GROUND ROD

A. General

1. Self contained ground rod(s) using chemically enhanced grounding shall be provided where specifically indicated on the drawings. As manufactured by Lyncole XIT Grounding Systems, 22412 South Normandie Avenue, Torrance, CA. Telephone #(800) 962-2610; or Superior Grounding Systems, Irwindale, CA. Telephone #(800) 747-7925; or ERICO – Eritech Chemical Ground Electrode.
2. The ground rod shall operate from changes in atmospheric pressure pumping air through the ground rod, hygroscopically extracting moisture from the air to activate the ground electrolytic chemicals and improve the ground rod performance.
3. Ground rod system shall be UL-467 listed.
4. Ground rod system shall be 100% self-activating, sealed and maintenance free. The addition of chemical or water solutions shall not be required.

B. Ground Rod

1. Ground rod shall consist of a 2-inches nominal diameter hollow, copper tube. The tube shall be permanently capped on the top and bottom. Air breather holes shall be provided in the top of tube. Drainage holes shall be provided in the bottom and sides of the tube for electrolyte drainage into the surrounding soil.

2. The ground rod shall be chemically filled at the factory with environmentally non-hazardous water-soluble metallic salts to enhance electrical grounding performance.
3. Ground rod shall be a minimum of 10-feet long for straight (vertical) installation; or "L" shape minimum 20-feet long for horizontal installation.
4. Ground wire clamping "U-Bolt" with pressure plate on the top end of the tube sized for 1#2 through 500 MCM AWG ground electrode conductor connection, and stranded 4/0AWG copper pigtail exothermically welded to the side of rod for ground electrode conductor connection.

C. Ground Box

1. Precast concrete box with slots for conduit entrances. Approximately 10-inch diameter by 12-inches high. Cast iron grate flush cover with "Breather" slots XIT Box #XB-12.

D. Backfill Material

1. Natural volcanic, non-corrosive Bentonite Clay backfill material.
2. Shall absorb water at a minimum of thirteen times its dry volume or approximately 14 gallons for 50 pounds of clay.
3. PH value 8-10 with maximum resistivity of 2.5 OHMS-M at 300% moisture content by weight.

2.06 FLEXIBLE CORDS AND PORTABLE CABLES

A. General

1. Multi-conductor insulated flexible cable with jacket rated extra heavy duty, extra hard-use and high abuse duty; ozone, sunlight, grease, oil resistant-UL 83 and water resistant; rated for indoor/outdoor use.
2. Quantity of conductors and conductor sizes as indicated on the drawings but in no case less than five 16AWG.
3. Characteristics:
 - a. Conductors - stranded copper, soft annealed conforming to ASTM-B-174 and ASTM-B-172. 600 volt individually insulated and color-coded. Separate green insulated ground conductor. Aluminum conductors shall not be permitted for cords and cables.
 - b. Insulation - rubber conforming to UL 62; temperature range plus 105 Centigrade to minus 50 Centigrade.
 - c. Flame resistance shall conform with MSHA-P123-103.
 - d. Jacket - black for equipment connections and yellow for outlet connections. Rated for temperature range plus 105 Centigrade to minus 50 Centigrade, water, sunlight and ozone resistant. Permanently mark jacket a minimum of 40-inches on center with rated voltage, manufacturer's name, wire/insulation type, AWG conductor size and quantity (minimum 24-inches on center).

2.07 CABLE RACKS

- A. Cable racks, installed on the vertical walls of the structure, including hooks and porcelain insulator cable cradles, shall be sufficient to accommodate the cables and splices.
- B. Vertical racks shall be installed on all walls of the structure a minimum of 24-inches on center within 6-inches of floor and top of wall. A rack shall be installed within 18-inches of each corner of each wall. Additional racks spaced equally on each wall shall be installed; spacing between vertical wall racks shall not exceed 24-inches.
 1. Wall racks shall be slotted to accept removable hooks and lock hooks into place.
 2. Non-metallic, 50% (minimum) glass reinforced nylon or non-metallic material of the same characteristics.
 3. The installed cable racks, cable support hooks with arms and wall anchor bolts shall support the following minimum loads for each hook/arm, with a 200% minimum safety factor. Based on multiple hook/arms located not less than 9-inches on center along the entire vertical length of the support rack:

<u>Hook/Arm Length</u>	<u>Min. Weight Each Hook/ Arm Supported</u>	<u>Max. Allowable Hook/ Arm Deflection</u>
a. 8-inch	450 pounds	0.25-inch
b. 14-inch	350 pounds	0.37-inch
c. 20-inch	250 pounds	0.37-inch

(Based on load concentrated 1-inch from the end of each hook/arm.)

4. Racks shall be bolted to the precast and cast-in place structure walls, within 3-inches of each rack end and not less than 9-inches on center. Provide cast-in place or after-set drilled expansion concrete anchors.

PART 3 - EXECUTION

3.01 TRENCHING, FOOTINGS, SLEEVES

- A. Provide trenching, concrete encasement of conduits, backfilling, and compaction for the underground electrical work, in accordance with applicable sections of this specification.
- B. Provide footings for all post and/or pole-mounted lighting fixtures: concrete shall conform to the applicable sections of this specification.
- C. Sleeves
 1. Provide sleeves for raceways, conduit and wire/cables passing through the following construction elements:
 - a. Concrete and masonry foundations, floors, walls and slabs.
 - b. Gypsum, Lath, and plaster walls and ceilings.
 - c. Building structures (i.e., foundations, walls, floors, ceilings, beams, and roofs) with a fire rating exceeding 20-minutes.
 2. Sleeves shall extend 1.5-inches above and below floors, except under floor standing electrical equipment. Sleeves shall be flush with wall ceiling foundations and partitions exposed to public view and extend approximately 0.5-inches past penetration in fire rated construction. Sleeves shall be installed at exact penetration locations and angles to accommodate wire/cable, raceway and conduit routings.
 3. Joists, girders, beams, columns or reinforcing steel shall not be cut or weakened. Where construction necessitates the routing of conduit or raceways through structural members, framing or footings, written permission to make such installation shall first be obtained from the DISTRICT'S REPRESENTATIVE. Such permission will not be granted, however, if any other method of installation is possible.
 4. The layout and design of raceways and conduits located in or routed through masonry or reinforced beams or the DISTRICT'S REPRESENTATIVE shall review walls before any work is performed. All sleeving shall be accomplished according to the instructions of the DISTRICT'S REPRESENTATIVE and shall be accepted before any concrete is poured.
 5. Sleeves, raceways and conduit shall be located to clear steel reinforcing bars in beams. Reinforcing bars in walls shall be offset to clear piping and sleeves.
 6. Provide a continuous clearance between the inside of a sleeve and exterior of wire/cables, conduits and raceways passing through the sleeve not less than the following:
 - a. 0.5-inch clearance except as required otherwise.
 - b. 1.0-inch clearance through outside walls below grade.
 - c. 3.0-inch clearance through seismic joints.
 7. Sleeves set in fire rated construction shall be caulked between sleeve and building structure, additionally sleeves shall be caulked between the sleeve and the wire/cables, conduits/raceways passing through the sleeve. The caulking shall be a fireproof sealant, equal to the fire rating and temperature being penetrated. Clearance between components inside of sleeve and exterior of components passing through sleeve and between components inside the sleeve shall comply with fireproof sealant manufacturer's recommendations.
 8. Sleeve material:
 - a. In floor construction: Schedule 40 black steel pipe, with upper surface to be sealed watertight.
 - b. In concrete or masonry walls roofs or ceilings: Schedule 40 black steel pipe. When installed in roofs or outside walls, seal outer surface watertight.
 - c. In fire rated construction; 24 gauge galvanized iron or steel.

- d. Sleeves through waterproof membranes: Cast iron or Schedule 40 steel with flashing clamp device and corrosion resistant clamping bolts. Caulk space between pipe and sleeve and surfaces between sleeve and conduits sealed watertight.

3.02 GROUNDING

- A. Grounding shall be executed in accordance with all applicable codes and regulations, both of the State and local authorities having jurisdiction.
- B. Where nonmetallic conduit is used in the distribution system, the CONTRACTOR shall install the proper sized copper ground wire in the conduit with the feeder for use as an equipment ground. The electrical metallic raceway system shall be grounded to this ground wire.
- C. The maximum ground/bond resistance to the grounding electrode shall not exceed 1 ohms from any location in the electrical system. The maximum ground resistance of the grounding electrode to earth shall not exceed 5 ohms.
- D. Ground/Bond Conductors
 - 1. Provide an additional, dedicated, green insulation equipment ground/bond wire inside each conduit type and raceway as follows. Size the ground/bond conductors to comply with CEC/NEC requirements. The metal conduit or raceway shall not be permitted to serve (function) as the only (exclusive) electrical ground return path:
 - a. All types of nonmetallic conduit and all types of non-metallic raceways including but not limited to: RNMCM - Rigid Nonmetallic Conduit.
 - b. FMC - Flexible Metal Conduit.
 - c. LTFMC - Liquid Tight Flexible Metal Conduit.
 - d. Metal and non-metal raceways.
 - e. RMC - Rigid Metal Conduit.
 - f. EMT - Electrical Metal Tubing.
 - 2. The equipment ground/bond wire shall be continuous from the electrical circuit source point of origin to the electrical circuit end termination utilization point as follows:
 - a. Every conduit and raceway path containing any length of the above identified conduits or raceway.
 - b. Every conduit path and raceway path connected to any length of the above-identified conduits and raceways.
 - 3. The equipment ground/bond wire shall be sized as follows, but in no case smaller than indicated on the drawings. Install equipment ground/bond wire in each conduit/raceway, with the respective phase conductors:

<u>Feeder, Subfeeders & Branch Circuit Protection</u>	<u>Min. Equipment Ground Wire Size</u>
15 Amp	#12
20 Amp	#12
30 to 60Amp	#10
70 to 100 Amp	#8
101 to 200 Amp	#6
201 to 400 Amp	#2
401 to 600 Amp	#1
801 to 1000 Amp	2/0
1001 to 1200 Amp	3/0
1201 to 1600 Amp	4/0
1601 to 2000 Amp	250 MCM
2001 to 2500 Amp	350 MCM
2501 to 4000 Amp	500 MCM
 - 4. Isolated grounds - Raceways containing branch circuit or feeder phase conductors connected to panelboards equipment, or receptacles with isolated grounds or isolated ground bus shall contain a dedicated insulated ground conductor connected to the isolated ground system only. The isolated ground conductor shall be continuous the length of the raceways and connected only to the isolated ground terminals in addition to and independent

of the equipment bonding/ground conductor. The isolated ground conductor shall be sized as indicated above, for equipment ground/bond wire.

5. Splices in ground/bond wires shall be permitted only at the following locations:
 - a. Ground buses with listed and approved ground lugs.
 - b. Where exothermic welded ground/bond wire splices are provided.
 6. Provide ground/bond wire jumpers for conduit fittings with ground lugs, expansion and deflection conduit fittings at conduit fittings connecting between metallic and non-metallic raceways and to bond metal enclosures to conduit fittings with ground lugs.
- E. Where conductors are run in parallel in multiple raceways, the grounding conductor shall be run in parallel. Each parallel equipment-grounding conductor shall be sized on the basis of the ampere rating of the overcurrent device protecting the circuit conductors in the raceway. When conductors are adjusted in size to compensate for voltage drop, grounding conductors, where required, shall be adjusted proportionately in size.
- F. Ground conductors for branch circuit wiring shall be attached at each outlet to the back of the box using drilled and tapped holes and washer head screws, 6-32 or larger.
- G. Each panelboard, switchboard, pull box or any other enclosure in which several ground wires are terminated shall be equipped with a ground bus secured to the interior of the enclosure. The bus shall have a separate lug for each ground conductor. No more than one conductor shall be installed per lug.
- H. UFER Ground
1. In addition to all cold water and structural steel grounds provided to meet this specification, there shall be a main ground system of the UFER ground style.
 2. The UFER ground electrodes shall be a minimum of two (2) 20-foot lengths of #4/0 AWG bare stranded copper cable embedded horizontally in the cast in place concrete footing, extending in opposite directions in the footings. All portions of the ground electrodes shall be placed inside the concrete, between 2-inches and 4-inches from the earth surrounding the concrete.
 3. The lengths of cable shall extend in opposite directions in the footings, with the center end of each cable terminated onto the main electrical service ground bus for the main electrical service equipment.
 4. All wire cable connection terminations onto the ground bus shall be exothermic weld type.
 5. The "UFER" grounding electrode, embedded in concrete, shall be exothermically welded to each steel reinforcing bar (rebar) and each steel anchor bolt located within 18-inches of the grounding electrode inside the concrete. Note: Reinforcing steel (rebar), in concrete foundations, attached with metal "tie-wraps" and in direct physical contact to other adjacent rebar that is in turn exothermic welded to the UFER grounding electrode, may be classified as attached to the UFER grounding electrode, and does not require additional exothermic weld connections to the UFER grounding electrode.
- I. Provide a separate ground/bond insulated grounding electrode conductor, copper wire from the main electrical service ground bus to each of the following locations. The ground/bond conductor shall be sized to comply with applicable codes and as indicated on the drawings, but in no case smaller than the following:
1. Main service entrance equipment ground bus:
 - a. Services smaller than 1200 ampere 1.5-inch conduit with 1#4/0.
 - b. Services 1200 ampere and larger 2.5-inch conduit with 1#500MCM.
 - c. Where a separate ground bus is not required, connect ground to electrical equipment metal housing
 2. Each telephone backboard and signal system backboard location, 1.25-inch conduit with 1#1.
 3. Metal cold water pipe located inside the building, 1.5-inch conduit with 1#4/0.
 4. Outdoor underground metal cold water pipe, make connection five feet from the building, 1.5-inch conduit with 1#4/0.
 5. Each transformer (size as indicated and to comply with applicable codes).

6. Each service entrance ground bus and each separately derived ground rod system:
 - a. Services smaller than 1200 ampere 1.5-inch conduit with 1#4/0.
 - b. Services 1200 ampere and larger 2.5-inch conduit with 1#500MCM.
7. Separate 1.25 inch conduit with 1#2 (AWG) bonding conductor to each interior metal pipe system located in the same building, including but not limited to, the following:
 - a. Fire sprinkler system each stand pipe location (water based and non-waterbased).
 - b. HVAC chilled water supply and return, at each pump location.
 - c. Roof drains.
 - d. Waste liquid disposal systems.
 - e. Metal gas pipe service entrance and service meters.
 - f. Hydraulic elevator hydraulic pipes.

3.03 CONDUIT

A. General

1. The sizes of the conduits for the various circuits shall be as indicated on the drawings, but not less than the conduit size required by code for the size and quantity of conductors to be installed in the conduit.
2. Conduits shall be installed concealed from view. Install conduits concealed in walls, concealed below floors and concealed above ceilings, except as specifically noted otherwise.
 - a. Conduits shall not be installed in concrete floors.
3. The following systems shall be considered as circuits 100 volts and less, all other circuits shall be considered to be over 100-volts (power circuits) unless specifically noted otherwise: Fire alarm, energy management control, telephone, public address, data, computer, television, intercom, intrusion alarm and nurse call.
4. Conduits shall be provided complete with conduit bends, conduit fittings, outlet boxes, pullboxes, junction boxes, conduit anchors/supports, grounding/bonding for a complete and operating conductor/wire raceway system.
5. Metal and nonmetal conduits shall be provided mechanically continuous between termination connection points. Metal conduit shall be provided electrically continuous between termination connection points.
6. Individual conduit paths and home runs shown on the drawings shall be maintained as separate individual conduits for each homerun and path.
7. Conduits, conduit fittings and installation work occurring in classified hazardous materials locations shall comply with applicable code Class 1 Division 1 requirements, unless specifically noted otherwise.
8. Transitions between conduits constructed of different materials and occurring in above grade locations shall be allowed only at outlet boxes, junction boxes, pull boxes, and equipment enclosures unless specifically indicated otherwise. Provide outlet boxes and junction boxes.
9. Metal conduit terminating to nonmetal enclosures; terminating into metal enclosures with "concentric.ring" knockouts; terminating into metal enclosures with knockout reducing washers, including but not limited to equipment housings, outlet boxes, junction boxes, pull boxes, cable trenches, manholes, shall be provided with a ground/bonding lug integrated with the conduit termination conductor fitting construction, by the fitting manufacturer. The lug shall provide for connection of a grounding/bonding conductor (insulated or uninsulated). The grounding lug shall be located on the fitting, inside the termination enclosure.
10. The type of conduit, type of conduit fittings, and type of conduit supports and method of conduit installation shall be suitable for the conditions of use and conditions of location of installation based on the manufacturer's recommendations; based on the applicable codes and based on the requirements of the contract documents.

B. RMC Installation Locations

RGS, IMC conduits and RGS, IMC fittings shall be installed in the following locations:

1. Embedded in floors, walls, ceilings, roofs, foundations, and footings constructed with concrete.
2. Embedded in walls and foundations constructed with brick and masonry.

3. Interior of buildings, within 9-feet of finish floor lines for exposed conduit locations.
 4. Exterior of building for exposed conduit locations.
 5. Damp or wet locations, exposed or concealed locations.
 6. Exposed on roofs.
 7. In hazardous materials areas and locations; below hazardous materials areas and locations; above hazardous materials areas and locations.
 8. Exposed on utility service poles, for pole risers less than 9-feet above finish grade.
 9. RMC conduit and RMC fittings may be installed in any location where EMT and FMC conduit is permitted to be installed.
- C. PVC Coated RMC Installation Locations
PVC coated RMC conduit and PVC coated RMC fittings shall be installed in the following locations:
1. Underground conduit locations for elbows and bends with a radius of less than 36-times the conduit diameter.
 2. Underground vertical risers extending above grade.
 3. Entire length of underground conduits for the following circuits:
 - a. Audio microphones
 - b. Lighting dimming controls
 4. Installed in contact with earth or corrosive materials.
 5. Exposed in "cold" rooms and "refrigerated" rooms, rooms with a maintained temperature below 65 degrees Fahrenheit.
- D. EMT Installation Locations
EMT conduit and EMT fittings may be installed in the following locations, for circuit conductors operating below 600 volts to ground; locations containing only "non-hazardous materials"; only dry locations:
1. Concealed in hollow non masonry/non-concrete, metal stud frame and wood stud frame walls and floors.
 2. Concealed above ceilings.
 3. Exposed inside interior enclosed crawl spaces.
 4. Exposed interior locations placed 10-feet or higher above finished floors (except as described in paragraph below at lower heights).
 5. Exposed on walls and ceilings (any height) in the following dedicated function areas, interior enclosed room locations:
 - a. Indoor enclosed electrical equipment rooms and closets.
 - b. Indoor enclosed data and telecommunication terminal rooms and closets.
 - c. Indoor enclosed HVAC equipment rooms and closets.
 6. Any location where FMC is described to be installed, except as the final connection to rotating or vibrating equipment.
- E. FMC Installation Locations
FMC conduit and FMC fittings may be installed in the following locations for circuit conductors operating below 600 volts to ground; locations containing only "non-hazardous materials"; only dry, interior locations:
1. Concealed in hollow non-masonry metal stud frame and wood stud frame fully enclosed walls.
 2. Concealed above fully enclosed ceiling spaces.
 3. FMC conduit shall be installed in continuous lengths between termination points. FMC shall not be "spliced" or coupled directly to FMC or any other conduit type under any circumstance.
 4. The maximum continuous length of FMC that shall be installed between termination end points is 8-feet. Circuits requiring continuous conduit lengths exceeding 8-feet between termination end points shall be installed using either RMC or EMT conduits. FMC lengths shorter than 16-inches are prohibited.
 5. The minimum size FMC conduit shall be as shown on the drawings but not be less than the following:
 - a. FMC lengths of six feet or less, minimum FMC conduit size shall be 0.75-inch.

F. LTFMC Installation Locations

LTFMC conduit and LTFMC fittings shall be installed in the following locations for circuit conductors operating below 600 volts to ground; locations containing only “non-hazardous materials”:

1. Final electrical connection to vibrating or rotating equipment; control and monitoring devices mounted on vibrating and rotating equipment including the following. Minimum conduit length shall not be less than 24-inches:
 - a. Motor, engines, boilers, solenoids, and valves.
 - b. Fixed mounted “shop” (manufacturing) production equipment.
 - c. Fixed mounted food preparation equipment and “kitchen” equipment.
2. All locations where exposed flexible conduit connections are required, both indoor and outdoor.
3. Final connection to indoors electrical transformers. Minimum conduit length shall not be less than 24-inches; maximum conduit length shall not exceed 72-inches.
4. Do not install LTFMC located in environmental air plenums.

G. RNMC Installation Locations

RNMC conduit and RNMC fittings shall be installed in the following locations containing only “non-hazardous material”:

1. Underground, concealed below earth grade, unless specifically noted or specified otherwise.
2. Exposed on utility service poles, for pole risers at 9-feet or higher above finish grade, schedule 80 PVC only.
3. RNMC type “EB” conduit(s) shall be concrete encased along the entire length of the conduits for all installation locations.

4. Non-metal type raceways and RNMC type conduit shall not be installed inside buildings.

H. Combi-Duct Installation Locations

Combi-duct conduits shall be installed where shown on the drawings. Combi-duct shall be installed underground (below grade) as follows:

1. Do not install exposed or inside buildings above grade.
2. Provide a 0.25-inch pull rope in each inner duct.
3. Radius and elbows shall be rigid non-metallic, PVC, manufacturer factory fabricated, in lieu of PVC coated RMC conduit.
4. Inner ducts shall be supported by internal spacers inside the enclosing outer duct.
5. Provide end bell and three (3) hole “snug-plugs” at each entrance end of Combi-duct into pullboxes, manholes, equipment cabinets stubups and Combi-duct terminations. Compression type “snug-plugs” shall provide watertight and airtight seal between inner and outer ducts and around future cables installed in inner duct.

I. Conduit Installation

1. Conduit Supports

- a. Securely and rigidly support all raceways/conduits from the building structure. Raceways/Conduits shall be supported independent of all piping, air ducts, equipment ceiling hanger wires, and suspended ceiling grid systems. Secure conduit to structural element by means of UL listed and approved hangers, fasteners, “C” channels and pipe clamps.
- b. Provide conduit supports spaced along the length of the conduit as follows:
 - 1) RMC and EMT conduit, maximum not to exceed 96-inches on center; within 24-inches of each conduit bend and conduit termination location.
 - 2) FMC and LTFMC conduit, maximum not to exceed 24-inches on center; within 6-inches of each conduit bend and conduit termination location.
- c. Suspended conduit methods:
 - 1) Individual, suspended raceways/conduits separated by more than 12-inches from any other conduit and suspended from ceilings and roofs shall be supported as follows:

- a) Conduits smaller than 1.5-inches by means of hanger rods or hanger wires.
 - b) Conduits 1.5-inches and larger by means of hanger rods.
 - c) The conduit shall attach to the hangers with pipe clamps.
 - 2) Suspended raceways/conduits positioned within 24 inches of any other conduit shall be grouped and supported by hanger rods using trapeze type conduit support channels ("C" channels). Conduits shall individually attach to common channels side-by-side, with pipe clamps.
 - d. Non-suspended conduit methods:
 - 1) Individual raceway/conduits placed against wall/ceiling/floors, placed inside hollow wall/ceiling construction or structure framing (i.e., "dry- wall" or plaster hollow wall construction), shall be secured by means of individual pipe clamps and fasteners attached to the framing studs or other structural members and the conduit/raceway.
 - 2) Provide common "C" channel supports for all multiple raceway/conduits placed against vertical or horizontal surfaces and positioned within 24-inches of other raceways/conduits. Attach channels to the framing studs or other structural members. Attach the conduits/raceway individually to common channels, side-by-side, with pipe clamps.
 - 3) The use of toggle bolts is prohibited.
 - e. Conduit rising from floor for motor connection shall be independently supported if extending over 18-inch above floor. Support shall not be to a motor or ductwork, which may transmit vibrations.
 - f. Provide conduit anchoring, conduit support and conduit bracing systems conforming to Earthquake Seismic Zone 4 requirements. The conduit support/ anchoring system capacity shall include the weight of the conduits, conduit fittings, conduit supports and conductors/wires/cables installed in the conduits plus a 300% safety factor. Submit shop-drawing details showing each typical conduit anchor, conduit support and conduit brace location. Submit structural calculations performed by and signed by a Professional Structural Engineer (P.E.) with a P.E. license, registered in the state of California, U.S.A.
2. Conduit separation:
- a. Conduit installed underground or below building slab without full concrete encasement: Shall be separated from adjacent conduits of identical systems (i.e. signal to signal, data to data, power to power, control to control etc.) by a minimum of 3-inches. Conduits of non-identical systems (i.e. signal to power; data to power; power to control; signal to control, etc.) shall be separated by a minimum of 12-inches.
 - b. Conduit installed underground with full concrete encasement; shall be separated from adjacent conduits of similar systems (100 volt and less) by a minimum of 2-inches; conduits for non power systems (100 volts and less to ground) shall be separated by a minimum of 6-inches from power circuits (over 100 volts to ground); conduits for power circuits shall be separated from adjacent conduits of similar power systems (over 100 volts to ground) by a minimum of 3-inches.
 - c. Separation of conduits entering termination points or crossing other conduits may be reduced as required within 60-inches of the termination or crossing points.
 - d. Conduits containing Utility Company service circuits (i.e. electrical power, telephone, or cable television) shall be separated a minimum of 12-inches from all other utilities and conduits, with or without concrete encasement; metallic or non-metallic conduit, above grade or underground conduit locations.
 - e. Conduits shall be separated from hot water piping, exhaust flues/chimneys, steam piping, boilers, furnaces, ovens by a minimum of 12-inches.
3. Conduit stubs:
- a. Branch circuit and telephone conduits turned up from floor at the following locations shall terminate each conduit in a flush conduit coupling at the floor and then extend into partition or to equipment. Refer to DISTRICT'S REPRESENTATIVE'S drawings for location of walls and partitions.
 - 1) Interior demountable partitions.
 - 2) Below, into or adjacent to equipment not installed directly adjoining to a wall.
 - 3) Up from below the floor into hollow stud frame walls.
 - b. From each panel, and signal cabinet which is wall mounted, stub up from top of the panel/cabinet a minimum of (3) three 1-inch conduits to the nearest accessible ceiling

spaces or other accessible location. Where the floor below the panel is accessible or is a ceiling space, stub an additional (3) three 1-inch conduits from the bottom of the panel into the accessible space below the panel. Cap conduits for future use.

- c. Conduits stubbed underground outside of building line for future use shall be terminated a minimum of five feet clear (whichever distance is greater) of building or adjacent concrete walks and AC paving. The stubout conduit shall be capped. Provide concrete monuments, 6-inches by 6-inches by 15-inches deep, buried flush with grade over the capped ends. The face of monument shall be furnished with 3-inch square brass plates securely mounted and engraved with the number and size of conduits and type of service (i.e., "POWER", "TEL.", etc.).
 - d. Conduits stubbed into ceiling or floor spaces from outlets for telephone, video, computer/data or television shall be provided with an insulated throat bushing, on the end of each conduit stubout.
 - e. Conduit stubouts from outlet boxes and equipment located in hollow stud walls, into ceiling and floor spaces, shall be EMT or RMC conduit. The stubouts shall terminate into the ceiling and floor spaces with a conduit termination connector fitting.
 - f. Empty conduit stubs into building spaces and equipment shall be individually identified with a "ID-tag" located at each end of the conduit. The ID-tag shall state the origination point and termination point of the respective conduit (i.e., "from PNL-A/to Room #121"; "from outlet #24/to outlet #17 in Room #120"; etc.).
 - g. Provide a conduit termination fitting with insulated throat bushing and mechanical ground lugs at each conduit "stub-up" location.
4. Conduit concrete encasement:
 - a. Conduits which are run underground exterior to building slab shall be continuously concrete encased except, 15 and 20-ampere power branch circuit conduits underground do not require concrete encasement.
 - b. PVC rigid-non-metallic-type EB conduit, of any size and any location shall be continuously concrete encased the full length of the conduit installation, including under building slab.
 - c. Concrete for encasement of underground conduits shall be 2000-PSI 28-days cure strength with a mix of cement, sand, water and maximum of ¾-inch gravel. Concrete encasement of conduits shall be continuous without voids. The encasement shall extend 3-inches past the edges of all conduits on all sides of the circuit. Provide ten pounds of red oxide cement coloring uniformly mixed with each cubic yard of concrete for conduit encasement.
 - d. Conduits located below or adjacent to structural foundations shall be separated from the foundation by a minimum of 12-inches. Conduits located below structural foundations shall be fully and continuously concrete backfilled and encased between the bottom of the foundation to the bottom of the conduits. The concrete shall be 4000 PSI 28 day cure strength instead of 2000-PSI concrete.
 - e. Conduits of any size and type (including 15 ampere and 20 ampere power branch circuits) located under roads, paved areas and "transit-system" right of way shall be concrete encased.
 5. Underground conduits:
 - a. Three or more underground conduits larger than 1-inch in size and occupying the same trench shall be separated and supported on factory fabricated, non-metallic, duct/ conduit support spacers. The spacers shall be modular, keyed interlocking type, "built- up" to accommodate quantity, size orientation and spacing of installed conduits. The spacers shall maintain a constant distance between adjacent conduit supports and hold conduits in place during trench backfill operations. Minimum support spacer installation interval along with length of the conduits shall be as follows:
 - 1) Concrete encased conduits, not less than 8-feet on center.
 - 2) Non-concrete encased conduits, not less than 5-feet on center.
 - b. Provide trenching, excavation, shoring and Backfilling required for the proper installation of underground conduits. Tops of backfill shall match finish grade.
 - c. Bottoms of trenches shall be cut parallel to "finish grade" elevation. Make trenches 12-inches wider than the greatest diameter of the conduit.
 - d. Back-filling Trenches for Conduits without Concrete Encasement Requirements

- 1) Conduits which are not required by the Contract Documents to be concrete encased and are located exterior to building slab, shall be set on a 3-inch bed of damp clean sand. Conduit trenches shall be backfilled to within 12-inches of finished grade with damp sand after installation of conduit is completed. Remainder of backfill shall be native soil.
 - 2) Conduits located under a building which are not required by the Contract Documents to be concrete encased, shall be completely backfilled and compacted with clean damp sand to the same level as the building foundation pad.
 - 3) Provide a continuous yellow 12-inches wide flat plastic tracer tape, located 12-inches above the conduits in the trench. The tracer tape shall be imprinted with "Warning-Electric Circuits" a minimum of 24-inches on center.
- e. Backfilling trenches for conduits under paved areas:
- 1) In addition to the requirements of conduit concrete encasement, conduits under walkways, roads, parking lots, driveways, and buildings shall be cast in place concrete "slurry mix" backfill. The slurry mix shall cover each side and top of conduits and conduit concrete encasement. The slurry mix shall be continuous to the underside of the finish subgrade surface.
- f. Backfilling trenches for conduits with concrete encasement requirements by the contract documents:
- 1) Trenches with all conduits concrete encased, shall be backfilled with clean damp sand when located under building pads.
 - 2) Trenches with all conduits concrete encased and not located under a building pad and not located under paved areas, shall be backfilled with clean damp sand or native soil.
- g. Backfill material:
- 1) Sand and native soil backfill of trenches shall be machine vibrated in 6-inch lifts to provide not less than 90% compaction of backfill.
 - 2) Soil backfill shall have no stones, organic matter of aggregate greater than 3-inches.
 - 3) Concrete and slurry mix (2000-PSI) shall be machine vibrated during installation to remove "air-voids".
 - 4) The slurry mix shall consist of concrete, clean rock, clean sand and clean water mixture. Maximum shrinking of slurry mix shall not exceed 5% wet to dry.
- h. Do not backfill until District's Representative has approved installation and as-built drawings are up to date. Promptly install conduits after excavation has been done, so as to keep the excavations open as short a time as possible. Excess soil from trenching shall be removed from the site.
- i. Install underground conduit, except under buildings, not less than 24-inches below finished grade in non-traffic areas and 30-inches below finished grade in traffic areas, including roads and parking areas. Not less than 48-inches below finished grade under public/ private transit system right of way and railroad right of way. Dimensions shall be measured to the top of the conduit.
- j. Conduit crossing existing underground utilities shall cross below the bottom depth of the existing utilities. If the top portion of the existing utility depth below finish grade exceeds 72-inches and the specified separation and depths are maintained when crossing over the top of the existing underground utility, the conduit may cross above the existing underground utility.
- k. Provide long radius horizontal bends (minimum radius of 36-times the conduit diameter) in underground conduits where the conduit is in excess of 100-feet long.
- l. Conduits installed below grade and on grade below buildings, shall not be smaller than 0.75-inches. Conduits for circuits exceeding 600-volts shall not be smaller than 5.0-inches.
- m. Underground conduits entering a building shall be sloped. The conduit direction of slope shall be away from the building, and shall prevent water in the conduit from "gravity draining" towards the building. The conduit slope "high point" shall originate from the building, out to the first exterior pullbox, manhole etc. exterior conduit termination "low point". The minimum slope angle shall be a constant 8-inches (or greater) of fall for each 100-feet of conduit length.

- n. Dewatering:
 - 1) Provide pumping to remove, maintain and dispose of all water entering the excavation during the time the excavation is being prepared, for the conduit laying, during the laying of the conduit, and until the backfill at the conduit zone has been completed. These provisions shall apply on a continuous basis. Water shall be disposed of in a manner to prevent damage to adjacent property. Trench water shall not be drained through the construction. Groundwater shall not be allowed to rise around the pipe until joining compound has firmly set.
 - 2) The DISTRICT'S Representative shall be notified 48 hours prior to commencement of dewatering.
- 6. Raceway/Conduits, which are installed at this time and left empty for future use, shall have 0.25-inch diameter polyvinyl rope left in place for future use. The pull rope shall be 500-pound minimum tensile strength. Provide a minimum of 5-feet of slack at each end of pull ropes.
- 7. Unless otherwise restricted by structural drawings and specifications, the maximum size conduit permitted in concrete slab on-grade, walls, ceilings and roofs constructed of masonry or concrete shall not be greater than 20% of the concrete/masonry thickness. Conduits installed in these locations shall not cross.
 - a. Conduits shall not be installed in cast-in-place concrete floors.
- 8. Provide openings in building structures for conduit penetrations:
 - a. New construction shall be provided with conduit sleeves, to provide conduit penetrations.
 - b. Existing construction shall be drilled (core drill masonry and concrete) and provide conduit sleeves installed after drilling, to provide conduit penetrations.
 - c. Where the structure penetrations for underground conduits penetrating through foundations will not comply with the (restriction/penetration) shown in the Contract Documents, install the conduits below and clear of the foundation lowest point.
- 9. Conduit bends risers and offsets:
 - a. The minimum bend radius of "factory or field" fabricated conduit bends shall not be less than the following. The bend radius shall be measured at the surface, inside radius of the conduit wall:
 - 1) FMC and LTFMC conduit - conduit minimum bend radius 12-times the conduit diameter.
 - 2) RMC and EMT conduit minimum bend radius - conduit for power circuits over 100 volts and less than 600 volts, 8-times conduit diameter. Conduit for power circuits over 600 volt, 12-times conduit diameter. Conduit for low voltage, signal and fiber optic circuits, 10-times conduit diameter.
 - 3) RNMC conduit - conduit minimum bend radius 36-times the conduit diameter. Under building reduce minimum bend radius to 10-times the conduit diameter. Conduit bends and offsets in RNMC with less than 36-times conduit diameter bend/offset radius, shall be RNMC PVC schedule 80 or PVC coated RGS.
 - 4) Conduits for utility company conductors. Conduit minimum bend radius shall comply with the respective utility company requirements.
 - b. Bends and offsets in conduits shall be kept to an absolute minimum. The total summation of all bends and offsets permitted in a conduit segment, occurring between two conduit termination/ connection end points, shall not exceed the following, including conduit fittings:
 - 1) RMC and EMT conduit - 360 angular degrees
 - 2) FMC and LTFMC conduit - 180 angular degrees
 - 3) RNMC conduit - 270 angular degrees
 - c. Each field fabricated conduit offset, bend and elbow which are not the standard product of the raceway/conduit manufacturer shall be mandrel tested. The test shall be conducted after the conduit installation is complete and prior to pulling-in any wire, in the same manner as for underground conduits.
 - d. Factory manufactured angle connector conduit fittings shall be installed in exposed conduit locations only. Installation in locations normally concealed from view shall not be permitted. Not more than one (1) factory manufactured angle connector shall be permitted in any length of conduit between conduit termination end points.

- e. RNMC conduit risers from below grade shall be PVC coated RGS. Conduit risers, bends or offsets entering into a building shall be PVC coated RGS.
 - f. If three (3) or more conduit-bends of the same conduit size and same conduit material type, installed, as part of the contract work, fail to comply with the required minimum conduit bend radius or conduit angular degree limits. The following corrective actions shall occur:
 - 1) The CONTRACTOR shall remove all the non-complying conduit bends and the respective wire in the conduit from the project site. Provide new conduit and wire, complying with the contract documents.
 - 2) Where the conduit bends similar to the non-complying conduit bends are installed concealed in walls, floors, above ceilings or below grade, the Contractor shall expose the conduit bends to allow visual observation.
 - 3) The CONTRACTOR shall remove the non-complying conduit bends and dispose off the project site. The CONTRACTOR shall provide new conduit bends and conductors complying with the contract documents.
 - 4) All the costs to correct the deficient material and work along with costs to repair the direct, indirect, incidental damages and contract delays shall be the sole responsibility of the CONTRACTOR and shall be included in the bid price.
10. Expansion joint, deflection joint and seismic joint fittings.
- a. Provide a conduit expansion fitting for each conduit length and conduit type as follows (Note - The installation of specified combination expansion/deflection fittings at seismic joints shall satisfy this spacing requirement also):
- | <u>Conduit Type</u> | <u>Conduit</u> | <u>Fitting Length Spacing</u> |
|---------------------|--------------------------------------|-------------------------------|
| 1) RMC and EMT | Exposed exterior locations | 200-feet |
| 2) RMC and EMT | Interior weather protected locations | 400 feet |
- b. Provide a conduit combination expansion/deflection fitting for each conduit, crossing the following elements:
 - 1) At each building or non-building structure seismic joint.
 - 2) At each building on non-building structure expansion joint.
 - 3) At each conduit penetration of a "sound-rated" wall, floor or ceiling.
11. Provide two (2) locknuts and an insulated throat bushing at each metal conduit terminating at enclosures, including but not limited to outlet boxes, junction boxes, terminal cabinets, switchgear, transformers, switchboards, distribution panels and panelboards.
12. Provide metallic or plastic closure caps on all conduit ends during construction, until installation of conductors in the respective conduit.
13. Conduit run exposed, shall be run at right angles or parallel to the walls or structures. All changes in directions, either horizontally or vertically, shall be made with conduit outlet bodies as manufactured by Crouse Hinds, OZ or equal. Conduits run on exposed beams or trelliswork shall be painted to match surrounding surfaces.
14. Conduit exposed on roof:
- a. Conduits installed exposed on roofs shall be limited on the project and be approved by Architect beforehand. When approved, they shall be installed on conduit sleepers. Place the conduit sleepers a maximum 5-foot on center along the entire length of the conduit; under conduit expansion/deflection fittings; under each junction box and within 24- inches of each conduit bend.
 - b. Provide a conduit support "C" channel continuous along the top length of the sleeper and rigidly bolted to the sleeper. Conduits shall be loosely fastened to each sleeper "C" channel with pipe clamps to allow for relative movement between the sleeper and conduit.
 - c. Conduits shall not block or interfere with roof hatches, doors, ventilation openings, dampers, equipment access panels/doors, roof water drainage.
 - e. Conduit sleepers shall be fabricated, MIFAB C-Port Rubber Support or MIRO Industries with Polycarbonate base, or equal. Sleeper length shall extend a minimum of 9-inches past the conduits attached to the sleeper, but in no case shall the length of the sleeper be less than 24- inches.
 - f. Provide a pad under each sleeper, sleepers shall not be installed in direct contact with the roofing. Sleeper pads shall extend a minimum of 6 inches past each side of the sleeper. The sleeper pad shall be semirigid mineral surfaced composition board, not

- less than 0.375-inch thickness, bituminous impregnated, manufactured for application on the specific roofing material. Remove roofing “ballast” (gravel) under pad, prior to installation of sleeper pad. Do not puncture roof membrane.
- g. Position the “length” of the conduit sleepers’ perpendicular to the roof slope, to prevent obstruction of roof drainage water flow. Where the conduit routing prevents placing the conduit sleeper parallel to the roof slope, provide two separate sleeper pads for the conduit sleeper, with a continuous 3-inches wide water drainage gap between the sleepers. Align the water drainage gap to allow unimpeded water travel along the roof slope drainage flow line between the pads.
15. Rigid steel conduit or electrical metallic tubing shall not be strapped or fastened to equipment subject to vibration or mounted on shock absorbing bases.
 16. RMC conduit threads:
 - a. Machine cut threads on RMC conduit required for field fabrication shall comply with NPS and ANSI-B1.20.1.
 - b. The length of bare metal exposed during thread fabrication shall be completely covered by conduit couplings and fittings. Additionally, the thread length shall insure that conduit joints will reach “torque” tightness and become secure before conduit ends “butt” together and before conduit ends “butt” into the “shoulders” of other conduit fittings.
 - c. Running threads or right/left handed threads shall not be used to connect RMC.
 17. RNMC conduit:
 - a. Joints and fittings shall be solvent welded to RNMC conduit. Joints and fittings shall be watertight and airtight after fabrication.
 18. Tighten each conduit fittings and fitting appurtenance, to the “torque” (allowable tolerance 5%) value recommended by the fitting manufacturer and applicable code. If three (3) or more conduit fittings are found to not be in compliance with the manufacturer’s “torque” (tightness) recommendations, the following corrective actions shall occur:
 - a. The CONTRACTOR shall tighten “re-torque” the defective fittings and all similar conduit fittings installed as part of the contract documents in the presence of the District’s Representative.
 - b. If the respective conduit fittings similar to the deficient “torque tightness” fittings are installed concealed in walls, floors, above ceilings or below grade, the CONTRACTOR shall expose the fitting, to allow retightening each similar conduit fitting to the manufacturers recommended “torque” values.
 - c. All the cost to repair the direct, indirect, incidental damages and contract delays resulting from complying with these requirements shall be the sole responsibility of the CONTRACTOR and shall be included in the bid price.
 19. Horizontal directional boring for underground conduit:
 - a. Provide a directional guided horizontal “bore-hole” underground conduit installation where one or more of the following conduits occur:
 - 1) Continuous trenching excavation and backfill for conduit installation is not permitted by the contract.
 - 2) Where continuous trenching excavation due to the existing surface and below grade conditions and restrictions, is not possible or practical to excavate a trench.
 - b. Provide “path-tracing” of the underground bore head, from the surface, along the entire horizontal bore length. Path tracing shall use electronic transmitters and receivers, continuously communicating the underground bore head locations and depth to the bore equipment operator. The directional boring system shall employ active tracking and directional position/steering control of the bore equipment drill head location. The active tracking system shall provide a portable receiver/transmitter unit for tracking the position of the moving drill head; a sensor “Sonde” unit on the drill head for tracking signals to the receiver /transmitter; and a drill head tracking data view display located at the boring equipment operator position to view the drill head position information sent

from the portable receiver/ transmitter. As manufactured by SPX-Radiodetection Company or similar products.

- c. Provide vertical pilot excavations not more than 50-feet on center along the path of the bore-hole to intercept the horizontal bore-hole routing, provide excavations at the beginning and end terminals staging points of the horizontal bore-hole.
- d. Provide full-depth "shoring" of the vertical pilot excavations. Remove the shoring, backfill, compact and repair the excavations when conduit installation is complete.
- e. "Drilling-fluid" shall be used during "back-reaming" and "pullback", pumped through the drill pipe to the bore drill head.
- f. Directional guided horizontal drilling shall employ equipment specifically designed and manufactured for the process. The equipment manufacturer shall train bore equipment operating personal in the proper operation of said equipment.
- g. Locate the position, size, depth and identify all underground "cross-bore" existing underground utilities, pipes, structures and conflicts along the entire bore path of each underground bore, prior to initiating directional boring work. Notify respective agency for each "cross bore" potential crossing. Comply with the recommendations of the Cross Bore Safety Association (CBSA).
- h. Horizontal, directionally guided boring equipment, as manufactured by Ditch Witch; Vermeer Manufacturing; or Case Corporation.

J. Conduit Seals

1. Provide conduit seal fittings at each location where a conduit transitions or passes through the following areas and where indicated on the drawings:
 - a. Refrigerated areas.
 - b. Temperature control rooms including warming rooms, steam rooms, saunas etc.
 - c. Classified hazardous material areas.
 - d. Water intrusion areas.
2. Provide conduit seals on each conduit entering a building from a below grade area located outside the building (i.e., basement, vault etc.) and connecting to the following types of equipment
 - a. Transformers
 - b. Panelboards
 - c. Motor control centers
 - d. Switchboards
 - e. Switchgear
 - f. Motors
 - g. Terminal cabinets
 - h. Terminal backboards
 - i. Cable trenches
3. Conduit seals shall be installed in locations where the fitting is visible and accessible.

K. Nailing Shields

1. Provide "nail" shields where FMC conduit and conductors not installed in a conduit are installed through wood stud and wood frame construction. The nail shield shall provide a barrier resistant to "nailing" fasteners through the stud, and penetrating into the FMC and conductors.
2. The nail shields shall be flat nominal 1.5-inch x 3-inches, 14-gauge steel, and hot dip zinc galvanized with "nailing spurs".
3. Provide nailing shields on the front face and rear face of each FMC penetration. The shield shall be centered on each penetration through the respective framing, stud framing blocking, and stud framing plates.

L. Conduit Bodies

1. Conduit bodies shall be installed in exposed conduit locations only or above accessible ceilings.
2. Conduit bodies shall be accessible for removing body cover and pulling wire through the conduit body.
3. Conduit bodies shall not be installed inside enclosed walls.

- M. Preparation of Reuse of Existing Conduits
1. Prepare existing conduits shown to be reused as part of contract work as follows: Complete the required work prior to installing any conductors or cables in respective existing conduits.
 - a. "Rod" out existing raceways to be used under this contract, with approved test and flexible mandrels to remove all obstructions to clear debris from inside conduits.
 - b. Use test mandrels at least 12-inches long, 0.25-inches less than diameter of duct at center, tapering to 0.5-inches less than duct size at ends.
 2. If test mandrels cannot be pulled through raceways, CONTRACTOR shall perform the following to clear the existing raceways:
 - a. Force rigid or semi-rigid rods through the raceways to clear the obstructions from one to both ends of the raceway.
 - b. Force a power driven rotating router device through the conduit from one or both ends of raceways. Device shall incorporate small diameter cutting blades. Repeat the "router" process in incremental stages to a cutting blade diameter approximately 1/8-inch smaller than the raceway inside diameter.
 3. After clearing the raceway of obstructions, pull a test mandrel or brush through the raceway to clear the remaining debris from the raceway.

3.04 WIRE AND CABLE

- A. Branch circuit and fixture joints for #10AWG and smaller wire shall be made with UL-approved connectors listed for 600 volts, approved for use with copper and/or aluminum wire. Connector to consist of a cone-shaped, expandable coil spring insert, insulated with a nylon shell and two (2) wings placed opposite each other to serve as a built-in wrench or shall be molded one-piece as manufactured by 3M-"Scotchlok".
- B. Branch circuit joints of #8AWG and larger shall be made with screw pressure connectors made of high strength structural aluminum alloy and UL-approved for use with both copper and/or aluminum wire as manufactured by Thomas & Betts. Joints shall be insulated with plastic splicing tape, tapered half-lapped and at least the thickness equivalent to 1.5-times the conductor insulation. Tapes shall be fresh and of quality equal to Scotch.
- C. Use UL listed pulling compound for installation of conductors in conduits.
- D. Correspond each circuit to the branch number indicated on the panel schedule shown on the drawings except where departures are approved by the DISTRICT'S REPRESENTATIVE or the DISTRICT'S Representative.
- E. All wiring, including low voltage, shall be installed in conduit.
- F. Control wiring to conform to the wiring diagrams shown on the mechanical drawings and the manufacturer's wiring diagrams.
- G. All splices in exterior pull boxes and light poles shall be cast resins encapsulated.
 1. Power conductor splices - 3M Scotchcast Series 82/85/90; Plymouth or equal.
 2. Control and signal circuits 3M Scotchcast series 8981 through 8986, Plymouth or equal.
- H. Neatly group and lace all wiring in panelboards, motor control centers and terminal cabinets with plastic ties at 3-inch on centers. Tag all spare conductors.

3.05 CHEMICAL GROUND ROD

- A. General
 1. Install ground rod system in compliance with manufacturer's instructions.
 2. Install rods vertically. Where subterranean hard rock conditions prevent vertical installation horizontal "L" shape ground rod shall be installed.
 3. Where ground rod is installed in an indoors dry location set ground box flush with finish floor. Where ground rod is installed outdoors set the top of the ground box four inches above finish grade.
 4. Do not remove sealing tape from ground rod holes until time of installation in ground.

5. Separate ground rods from all other grounding electrodes and from each other by not less than 12-feet horizontal distance.
- B. Excavation
1. Vertical installation bore a 12-inch diameter vertical hole in the ground six inches deeper than ground rod length.
 2. Horizontal installations excavate a 12-inches wide trench, slope rod and trench to insure end cap of rod is 2-inches lower than the elbow.
- C. Backfill
1. Surround the entire rod with a minimum of 10 inches of bentonite clay mixed with water at six times volume to form a paste. Approximately 14-gallons for each 50-pounds of clay. Remove any excavation liners from the rod excavation area.
 2. Install ground box and complete backfill.
- D. Connect grounding electrode conductor(s) to ground rod.

3.06 CABLE RACKS

- A. General
1. Provide cable racks in precast and cast-in place concrete pullboxes, manholes and cable trenches, and ensure that all cables, conduits, or conductors of line or high voltage, are neatly assembled and are a minimum of 4" from the bottom of the boxes.

3.07 TESTING

- A. Testing Conduit and Conduit Bends
- The CONTRACTOR shall demonstrate the usability of all underground raceways, and field fabricated conduit bends installed as part of this contract.
1. A round tapered segmented semi-rigid mandrel with a diameter approximately ¼-inch smaller than the diameter of the raceway, shall be pulled through each new raceway.
 2. The mandrel shall be pulled through after the raceway installation is completed. Conduits which stubout only, may have the mandrel pulled after the concrete encasement is completed, but prior to completing the backfill.
 3. DISTRICT'S REPRESENTATIVE shall witness the raceway testing for usability. A Representative of the Respective Utility Company shall witness the raceway testing where applicable.
 4. CONTRACTOR shall repair/replace any conduit and conduit bend provided under this contract which will not readily pass the mandrel during this test.

END OF SECTION

SECTION 26 05 36
CABLE TRAY

PART 1 - GENERAL

1.01 SCOPE

- A. Work Included: All labor, materials, appliances, tools, equipment, facilities, transportation and services necessary for and incidental to performing all operations in connection with furnishing, delivery and installation of the work of this Section, complete as shown on the drawings and/or specified herein. Work includes, but is not necessarily limited to the following:
 - 1. Examine all other sections for work related to those other sections and required to be included as work under this section.
 - 2. General provisions and requirements for electrical work.

1.02 SUBMITTALS (ADDITIONAL REQUIREMENTS)

- A. Submit product data sheets for all cable trays, all related components, and NEMA VE1.
- B. Submit cable tray support details.
- C. Provide reproducible floor plan shop drawings, with the same scale as the contract floor plan drawings. The drawings shall show the proposed cable tray layout plan views. A elevation view shall be provided at each riser or change in horizontal elevation in the cable tray. The shop drawing plans shall show all building elements, expansion/seismic joints, air ducts, piping and components that cross the path of the cable tray, along with separation of the cable tray from the crossing components.

PART 2 - PRODUCTS

2.01 CABLE TRAY

- A. Material and installation shall comply with NEMA - "VE1" latest edition, Cable Tray Systems', N.E.C., California Title 24 and Title 8. As manufactured by Globe Tray, Chalfant, P-W Industries or equal.
- B. Cable tray shall include two (2) longitudinal side rails, ladder type, with transverse 6 inches rung spacing welded to side rails. Rungs shall have a minimum cable-bearing surface of 0.75-inches. Rungs shall not extend below bottom of side rails. Splice plates shall be locking bolt type to connect tray sections together without decreased tray strength. Provide expansion/deflection fitting at each building seismic and expansion joint crossing.
- C. Trays shall be steel or aluminum. Steel trays shall be hot dip galvanized after fabrication ASTM A 123 with ANSI type 304 and 316 stainless steel hardware. Aluminum trays shall be extruded from 6063-T6-aluminum alloy with 5052-H32-aluminum alloy hardware.
- D. The complete cable tray system and supports shall be designed for the following minimum uniformly distributed working load but not less than indicated on the drawings, with a 1.5 minimum safety factor, when supported as a single span. In addition, the cable tray shall support 200 pounds concentrated at span midpoint without permanent distortion.
 - 1. Cable tray wider than 12-inches or deeper than 6 inches, live loading 200 pounds per linear foot.
 - 2. Cable tray 12-inches or less in width and 6 inches or less in depth live loading 100 pounds per linear foot.
- E. Provide ladder type "elbows", "tees", horizontal "crosses", expansion connectors, reducer sections, connectors, straight sections, curved sections, fittings, supports, hangers, blind ends,

risers and accessories to provide a complete installation of the cable tray shown on the drawings. Provide trapeze brackets and individual threaded hanger suspension rods in any

combination required to support the cable tray system. Provide all materials and labor necessary for a complete installation.

- F. Cable tray runs shall be minimum 6-inches deep by 12-inches wide, but not less than indicated on drawings. Dimensions are outside dimensions of the cable tray rails.
- G. Similar cable tray parts and hardware shall be interchangeable with each other. The cable tray system shall be free of sharp edges, burrs or projections that can damage cable insulation.

PART 3 - EXECUTION

3.01 CABLE TRAY

- A. Cable trays shall be seismically anchored and supported to the building structure to prevent horizontal or lateral movement with 1.0-gravity acceleration, including specified live load conductor capacity, complying with State of California seismic codes. Support hangers from the building structure shall provide a 2.0 weight carrying safety factor including specified live cable weight. Cable tray hangers shall be provided with a spacing to insure the maximum cable tray deflection with the specified live cable loading does not exceed 0.75-inches between supports and hangers. In no case shall cable tray support or hanger spacing be greater than 12-feet on center.
- B. Punching or drilling of structural side members shall not be performed except for splice plate bolt-holes.
- C. Provide expansion adapters where cable trays cross a building expansion joint, and to comply with tray manufacturer's recommendation for the cable tray thermal expansion requirements.
- D. All cable trays including non-connected tray sections shall be made electrically continuous. Provide grounding jumpers minimum equivalent to #8AWG, where required to provide continuity.
- E. Grounding for cable trays shall comply with Article 318-6 of NEC.
- F. Provide curved "radius" cable trays at each "horizontal" or "vertical" change in direction of the cable tray. Provide "tee" and "crosses" at each intersection of cable trays. Provide "blind ends" at the end of each cable tray "run".
- G. Provide removable fire blocking "bagstyle" at cable tray penetrations of fire barriers.

END OF SECTION

SECTION 26 05 43

PULLBOXES

PART1 GENERAL

1.01 SCOPE

- A. Work Included: All labor, materials, appliances, tools, equipment, facilities, transportation and services necessary for and incidental to performing all operations in connection with furnishing, delivery and installation of the work of this Section, complete as shown on the drawings and/or specified herein. Work includes, but is not necessarily limited to the following:
 - 1. Examine all other sections for work related to those other sections and required to be included as work under this section.
 - 2. General provisions and requirements for electrical work.

1.02 SUBMITTALS (ADDITIONAL REQUIREMENTS)

- A. Submit product data sheets for all racks, hooks, supports, ladders, covers, grounding, manholes, vaults, pullboxes, joint sealing compound etc.
- B. Submit detailed shop drawings including dimensioned plans, elevations, details, structural calculations signed by a California State registered Structural ENGINEER and descriptive literature for all component parts.

PART 2 PRODUCTS

2.01 GENERAL

- A. Each concrete precast section shall be identified by having the manufacturer's name and address, along with respective section weight cast into an interior face or permanently attached thereto. Associated Concrete Products, Jensen Precast Products, Brooks Products or equal.
- B. Structure Construction
 - 1. The precast steel reinforced concrete structure walls, floor and roof shall safely sustain the loads and pressure resulting from vertical and lateral earth loading and vehicular loading. Based on the following criteria:
 - a. Minimum earth density shall be 120 lbs./cu.ft.
 - b. Minimum equivalent fluid pressure for lateral pressure due to earth shall be 85 lbs./sq.ft. undrained earth conditions, minimum safety factor for buoyancy shall be 1.25.
 - c. Vehicular load rating shall be H-20 in compliance with latest AASHTO specifications.
 - d. Design shall be based on maximum depth of fill over the structure as indicated on the drawings, but not less than 36 inches.
 - e. Design and details shall comply with minimum ACI 318-63 code requirement. Minimum concrete 28 day cure strength shall be 3,000 psi.
 - 2. Precast structure shall be designed to withstand forces due to additional inward load of 4,000 pounds (working load) with safety factor of two (2), acting perpendicular to the surface at any pulling iron.
 - 3. Structures shall be single piece or horizontal multi-section construction as required for field installation conditions. Multi-sections shall interlock with "Tongue and groove" joint mating surfaces to insure a rigid assembly.
 - 4. All structure precast joints shall be sealed with preformed cold field applied plastic joint sealing compound. Joint sealing compound shall not leak, sag or flow at the joints with 10 psi water pressure applied for 24 hours. Chemically resistant to acid, alkali's and saturated hydrogensulfide.
 - 5. Each precast structure section shall have suitable knockouts or openings in the vertical walls for the duct banks and conduits entering the structure. Provide a 1 inch diameter

knockout in each corner of the floor slab, 6 inch from adjacent walls, for installation of ground rods.

C. Intercept Manhole/Pullbox Structures

1. Intercept type manhole/pullbox structures shall comply with the requirements of non intercept manholes and pullboxes, respectively. Plus the additional requirements listed below.
2. Manholes/pullboxes shown to be installed at the same location as replacement for existing manhole/pullbox shall be custom fabricated "intercept" multi-section type.
3. The structure shall be provided with multiple, vertical and horizontal custom fabricated sections for fitting around existing manholes/conduits/duct banks/conductors entrances into the structure during manhole installation without disturbing existing manholes/pullboxes. The structures shall allow placement of the structures without disconnecting or disrupting existing circuits during the installation. The structure walls shall be slotted to fit around existing concrete encased conduit entrances.
4. Provide cast-in-place concrete steel reinforced foundation/footings and floor for the intercept structure. The foundation shall be installed prior to removal of existing manhole/pullbox. The floor shall be installed after removal of the existing manhole/pullbox structure. The foundation/footing and floor shall be designed, and engineered as part of precast structure.
5. The structure foundation/footings shall be "keyed" to match keying of manhole precast wall sections.

2.02 PULLBOXES

- A. Pullboxes shall have deep recess conduit knockout concrete extensions at two opposite end walls. Additional shallow recess knockouts shall be provided on the other two walls for conduit entrances.
- B. Pullboxes shall be provided with a minimum of one precast concrete 6 inch extension grade ring "tongue and groove" matting surfaces to insure rigid assembly.
- C. Pullbox sizes shall be as indicated on drawings but in no case less than required by applicable codes. Minimum depth of the pullbox shall not be less than 42 inch.
- D. The pullbox floor sump shall extend through the concrete floor into the gravel bedding, below the pullbox.

2.03 COVERS AND FRAME ASSEMBLIES

- A. Traffic rated per AASHO for H20 loading.
- B. Pullboxes
 1. Hot dip galvanized steel single piece flush fitting with threaded flush hold down, slotted head, stainless steel studs.
 2. Topping frame shall be hot dip galvanized steel angle frame where the pullbox is installed in paving or concrete work.
 3. Top ring frame shall be armor band type where the pull box is installed in exposed earth or landscaping.
 4. Cover openings larger than eight (8) square feet of surface area, shall be provided with "split" two (2) piece cover type. Each "split" cover shall be hinged open-close with Torsion Spring type cover, to assist in the ease of opening and closing the cover.
 5. Cover openings eight (8) square feet or smaller surface area shall be single piece covers.
- C. Covers shall be permanently marked in the cover metal as follows:
 1. "E" or "Electric" for covers on structures containing power circuits under 600 volts and "HV" or "High voltage" for covers on structures containing power circuits over 600 volts.
 2. "Signal" for covers containing signal circuits.

2.04 CABLE RACKS

- A. Cable racks, installed on the vertical walls of the structure, including hooks and porcelain insulator cable cradles, shall be sufficient to accommodate the cables and splices.
- B. Vertical racks shall be installed on all walls of the structure a minimum of 24-inches on center within 6-inches of floor and top of wall. A rack shall be installed within 18-inches of each corner of each wall. Additional racks spaced equally on each wall shall be installed, spacing between vertical wall racks shall not exceed 24 inches.
 - 1. Wall racks shall be slotted to accept removable hooks and lock hooks into place.
 - 2. Non-metallic, 50 percent (minimum) glass reinforced nylon or non-metallic material of the same characteristics.
 - 3. The installed cable racks, cable support hooks with arms and wall anchor bolts shall support the following minimum loads for each hook/arm, with a 2000 percent minimum safety factor. Based on multiple hook/arms located not less than 9-inches on center along the entire vertical length of the support rack:

<u>Hook/Arm Length</u>	<u>Minimum Weight Each Hook/Arm Supported</u>	<u>Maximum Allowable Hook/Arm Deflection</u>
a. 8-inch	450 pounds	0.25-inch
b. 14-inch	350 pounds	0.37-inch
c. 20-inch	250 pounds	0.37-inch

(Based on load, concentrated 1-inch from the end of each hook/arm.)

- 4. Racks shall be bolted to the precast and cast-in place structure walls, within 3-inches of each rack end and not less than 9-inches on center. Provide cast-in place or after set drilled expansion concrete anchors.

2.05 PULL-IN-IRONS

- A. Pull-in-irons shall be a galvanized steel bar bent in a "U" shape, and cast in the structure walls and floors.
- B. A floor pull-in-iron shall be centered under the manhole entry ring in the structure floor.
- C. Pull-in-irons shall not be less than 6 inches above or below, in the opposite wall from each knockout panel for conduit entrances.
- D. Pull-in-irons shall project from the structure wall into the structure approximately four inches.

2.06 DRAINAGE SUMPS

- A. Provide drainage sump with cast iron metal grate in the floor of each structure. Minimum diameter of 12-inches by 4-inches deep. Provide a removable cast iron grate over the sump.

PART 3 EXECUTION

3.01 EXCAVATION

- A. Excavate for installation of precast structures removes excess excavated material from the site. Saw cut existing paving and concrete as required for excavation.
- B. Provide a minimum of 6-inches deep bedding base of crushed rock 3/8-inch - 1/2-inch size in the bottom of the excavation. Bedding shall be level and well compacted by a minimum of four passes with a plate type mechanical vibrator.
- C. Back fills and compact earth around precast structure after installation of the structure to 90-percent minimum compaction in 12-inch lifts. Replace paving concrete, landscaping above structure to match existing.

3.02 INSTALLATION

- A. Install precast structures per manufacturer recommendations to provide a dry watertight installation. Set cover flush with existing grade or finish surface. Where precast structure is installed in pedestrian walkway or vehicular traffic way with a sloping finish grade. Slope cover to match existing finish surface slope.
- B. Install structures to avoid surface water drainage flow lines, and existing utilities.
- C. Exterior concrete walls tops and bases of precast structure shall be damp-proofed with two coats of a bituminous damp-proofing material, minimum finish thickness 4-mil.
- D. Connections to Precast Structure
 - 1. Lines connecting to precast structures shall be constructed to have a cast in place concrete tapered section adjacent to the structure and extending a minimum of 48 inch out from the structure to provide shear strength.
 - 2. Precast structure shall be constructed to provide for keying the concrete envelope of the conduit into the wall of the structure. Mechanical vibrators shall be used when this portion of the envelope is poured to assure a seal between the envelope and the wall of the precast structure.
- E. Entrances of conduits/ducts shall terminate with endbells inside the precast structure. Slope conduit entrances into manhole to insure top of conduit entrances into manhole are a minimum of 6-inches below manhole ceiling. Maximum conduit slope shall not exceed 1-inch per "running" foot of conduit.
- F. Manholes and pullboxes shown to intercept existing conduit, remove portion of existing conduit approximately 4-feet back from manhole wall, regrade and excavate conduit entrance and extend existing conduit into manhole or pullbox to match existing conduit quantity and size. Provide "horizontal, split" conduit and split conduit coupling to extend existing conduit into manholes and pullboxes.

3.03 GROUNDING

- A. Provide 10-foot long by 0.75-inch diameter copper clad, steel, driven ground rods through the floor of the precast structure. Provide a minimum of two ground rods in opposite corners in manholes and vaults, one ground rod in pullboxes. Ground rod shall extend 6-inches above the floor line. Where rock bottom is encountered, bury ground rod in horizontal trench with projection into precast structure. Seal off openings around ground rods.
- B. Ground permanently and effectively together all metal equipment cases, metallic, cable racks, ladders, etc., with #4 bare copper bonding conductor. Provide U.L. compression bonding fittings at each ground connection.

END OF
SECTION

SECTION 26 08 00

ELECTRICAL LIGHTING SYSTEMS COMMISSIONING

PART 1 - GENERAL

1.1 SECTION INCLUDES

A. Section Includes:

1. General requirements for Commissioning (Cx) of lighting systems components and lighting controls including installation, start-up, testing and documentation according to Construction Documents and Commissioning Plan (CxP).
2. Standard procedures for the execution of commissioning work shall be in conformance with Division 1, Section 01 91 00 General Commissioning Requirements. Coordinate all work with the Commissioning Agent (CxA).

1.2 RELATED SECTIONS:

1. Provisions of Division 01 apply to this section.
2. Section 01 91 00: Commissioning.
3. Section 01 78 23: Operations and Maintenance Data Training.
4. Section 26 05 00: Common Work Results for Electrical.
5. Section 26 05 01: Electrical General Provisions.
6. Section 26 09 23: Lighting Control Systems.
7. Section 26 50 00: Lighting Fixtures.
8. Project Commissioning Plan.

1.3 REFERENCES

- ###### A. Applicable codes, standards, and references: all inspections and tests shall be in accordance with the following applicable codes and standards, except as provided otherwise herein:
1. National Electrical Testing Association – NETA.
 2. National Electrical manufacturer's Association – NEMA.
 3. American Society for Testing and Materials – ASTM.
 4. Institute of Electrical and Electronic Engineers – IEEE.
 5. American National Standards Institute – ANSI.
 6. National Electrical Safety Code – NESC.
 7. California Building Code – CBC.

8. California Electrical Code – CEC.
9. Occupational Safety and Health Administration – OSHA.
10. National Institute of Standards and Technology – NIST.
11. ANSI/NFPA 70 – National Electrical Code.
12. NFPA 70E – Electrical Safety Requirements for Employee Work Places.
13. ANSI/NFPA 101– Life Safety Code.

1.4 SUBMITTALS

- A. Submittals shall include the following:
1. Submit required Cx submittals in accordance with Division 1 Specification Sections.
 2. Copy of the Architect's reviewed and accepted submittals to the CxA via the OAR.
 3. List of team members who will represent the Contractor in the Pre-functional Equipment Checks and Functional Performance Testing, at least two (2) weeks prior to the start of Pre-functional Equipment Checks.
 4. Detailed manufacturer installation and start-up, operating, troubleshooting and maintenance procedures, checklist documentation and field checklist forms to be used by factory or field technicians, and a copy of full details of Owner-contracted tests, full factory testing reports, if any, and Warranty information, including responsibilities of Owner to keep Warranty in force, clearly defined.
 5. Detailed manufacturer's recommended procedures and schedules for Pre-functional Equipment Checks, supplemented by Contractor's specific procedures, and Pre-functional Tests, at least four (4) weeks prior to the start of Pre-functional Performance Tests.
 6. After facility's commission is complete, submit all completed Pre-functional Equipment Checklists and Functional Performance Test checklists organized by system and by subsystem. Bind all information in a single package. The results of failed tests shall be included along with a description of the corrective actions taken.

1.5 MEETINGS, SEQUENCING AND SCHEDULING

- A. Meetings: Attend (Cx) meetings as required under Section 01 91 00 and the Cx Plan.
- B. Sequencing and Scheduling: The work described in this Section shall begin only after all work required in related Division 26 Sections has been successfully completed, and all tests, inspection reports and Operation & Maintenance manuals required in Division 26 Sections have been submitted and approved. The start-up and Pre-functional Equipment Checklists shall be completed and submitted to the Owner's Authorized Representative (OAR) prior to the Functional Performance Tests. Refer to the project Cx Plan for more details.
1. Coordinate all electrical work with the work of other trades prior to

- scheduling of any Cx procedures.
- 2. Coordinate the completion of all electrical testing, inspection, and calibration prior to start of Cx activities.
- 3. Cx activities shall be scheduled in accordance with project's Cx plan.

1.6 QUALITY CONTROL

- A. Incorporate manufacturer's recommended Cx procedures for the systems and equipment to be commissioned under this Section.

PART 2 - PRODUCTS

2.1 TEST EQUIPMENT

- A. Equipment to be utilized in the commissioning process shall meet the following requirements:
 - 1. Provide test equipment as necessary for the equipment and systems to be commissioned.
 - 2. Provide testing equipment and accessories that are free of defects and certified for use.
 - 3. Provide testing equipment with current calibration labels per NIST Standards.
 - 4. All testing equipment shall be UL Listed.

PART 3 – EXECUTION

3.1 COMMISSIONING PROCESS REQUIREMENTS

- A. Work to be performed prior to commissioning:
 - 1. Complete all phases of the work so the system(s) can be started, tested, adjusted, balanced, and otherwise commissioned.
 - 2. If modifications or corrections to the installed systems are required to bring the system(s) to acceptance levels due to Contractor's incorrect installation or defective materials, such modifications or corrections shall be made at no additional cost to the Owner.
- B. Pre-commissioning Responsibilities: Inspection, calibration and testing of the equipment and apparatuses to commission the following systems:
 - 1. Electrical Lighting Systems.
 - 2. Lighting Controls.
- C. Commissioning Process Requirements:
 - 1. Refer to Section 019100 General Commissioning Requirements, related sections and Cx Plan for information on meetings, start-up plans, Pre-

Functional and Functional Performance Testing (FPT), operations & maintenance data, and other Commissioning activities.

3.2 PREPARATION

- A. Provide certified electricians or other qualified personnel as required with tools and equipment necessary to perform all Cx activities.
- B. Provide equipment manufacturer's factory representative(s) for commissioning of classrooms lighting and its control system as required by the Cx Plan.
- C. Provide certified testing agency personnel and/or report(s) as required in the Cx Plan.

3.3 TESTING

- A. Testing documentation shall include the following minimum information:
 - 1. Test number.
 - 2. Equipment used for the test, with manufacturer and model number and date of last calibration.
 - 3. Date and time of the test.
 - 4. Indication of whether the record is the first commissioning test or a retest following correction of a previously identified problem or issue.
 - 5. Identification of the system, subsystem, assembly, or equipment.
 - 6. Conditions under which the test was conducted, including (as applicable) ambient conditions, set points, override conditions, and status and operating conditions that impact the results of the test.
 - 7. Systems and assemblies test results, performance and compliance with contract requirements.
 - 8. Issue number, if any, generated as the result of the test.
 - 9. Name and signature(s) of witnesses and the person(s) performing the test.
- B. Test lighting and controls systems performance to verify operation, functionality, light levels, energy usage, and compliance with construction documents.
 - 1. Contractor shall start up, test and document results under the observation of the CxA.
 - 2. Contractor shall execute the Functional Performance Test (FPT) under the observation of the CxA who will record the results of the Functional Performance Test procedures.
 - 3. Equipment & Components to be tested: Refer to Article 3.01, B.
 - 4. Functions and Testing Conditions:
 - a. Occupancy sensors and timer controls for lighting:
 - 1) Verify that all specified functions and features are set up, debugged and fully operable at time of test.

- 2) Verify that occupant override feature functions properly and as intended in the contract documents.
 - 3) Verify that sensor durations are set properly.
 - 4) Test the sequence of operation for all features and modes and confirm that adjustable timing matches the design specifications and contract documents.
- b. Electric lighting dimming, photocells and controls:
- 1) Test the dimming controls during daytime when conditions are such that controls should be dimming electric lighting. Verify that amperage changes in light fixtures are proportional to external light changes. Verify that dimmed light levels at the specified work plane remain within specified limits.
 - 2) Verify that delays and ramp times are set and functioning so that the speed of change of light fixture output is slow enough to not bother occupants and in compliance with the specifications.
 - 3) Verify that dimming does not cause lower than specified light levels in adjacent “non-dimmed” spaces.
 - 4) Verify that the controls and sensors cannot be easily overridden or disabled by occupants.
 - 5) Verify that dimming systems in places of assembly are interfaced with the Central Fire Alarm system. Dimmed lighting in these areas shall come back to full bright during a fire alarm condition.
- c. Illumination Levels, Night Conditions:
- 1) Verify that lighting throughout the building is operating automatically.
 - 2) Test with doors closed (to simulate actual occupancy) and after finishes are complete.
- d. Illumination Levels, Day Conditions:
- 1) Verify that lighting throughout the building is operating automatically.
 - 2) Test with doors closed (to simulate actual occupancy), after finishes are complete, and room is furnished.
 - 3) Test at different times during the day, or under Owner-approved simulated conditions, to ensure proper system response and to determine that lighting levels are within specified requirements.
 - 4) Test the system for the different pre-determined settings. AV mode, and normal standard class operation.

- e. Lighting Power Density: Perform the test with all interior lighting turned on and any manual or automatic controls temporarily overridden. The lighting power shall be measured at the building's electrical panels. Measurements shall be taken at least one (1) minute after all lighting in the building is on.
 - f. Emergency Lighting System: Verify that the system operates automatically under any condition, without human intervention, and that it resets back to normal operations after the power failure is over or cleared.
5. Acceptance Criteria:
- a. Lighting Controls: For the conditions, sequences and modes tested, the dimming/occupancy/photocell/timing controls, integral components and related equipment respond to changing conditions and parameters appropriately as defined in the Contract Documents.
 - b. Illumination Levels: Average light levels in the tested space at the work plane elevation shall not be less than 10% below nor greater than 20% above the specified light level range for the space.
 - c. Lighting Power Density: Average instantaneous lighting power density is +/- 10% of that indicated in the Construction Documents. Power factors on lighting circuits shall be 0.95, or as required by lighting fixture specifications.
6. Sampling Strategy for Identical Units:
- a. Lighting Controls: Test all automatic interior lighting controls.
 - b. Illumination Levels: At least 50% of all space zones and rooms, chosen by the Owner, shall be verified as realizing proper light levels. If 25% of the spaces in the first sample fail the Functional Performance Tests, test another 10% of the untested space zones and rooms (the 2nd sample). If 10% of the spaces in the 2nd sample fail, test all remaining spaces.
 - c. Power Density: Test all lighting circuits.
- C. Contractor shall participate and perform all Cx related testing requirements prescribed under Sections 019100 and the approved project Cx Plan.

3.4 ADJUSTING

- A. Systems improperly adjusted, incorrectly installed equipment and/or deficient Contractor performance may result in additional work being required for Cx acceptance.
 - 1. Contractor shall perform all work required to correct installations not meeting contract requirements at no additional cost to the Owner.
- B. Corrective work shall be completed in a timely manner to permit completion of the Cx process.

1. Contractor shall refer to the Cx Plan for retesting requirements necessary to achieve required system performance.
2. If the systems' Cx deadline, as defined in the Cx Plan, goes beyond the scheduled completion of Commissioning without resolution of the problem, the Owner reserves the right to obtain supplementary services and/or equipment to resolve the problem.

END OF SECTION

SECTION 26 08 00

ELECTRICAL LIGHTING SYSTEMS COMMISSIONING

PART 1 - GENERAL

1.7 SECTION INCLUDES

B. Section Includes:

1. General requirements for Commissioning (Cx) of lighting systems components and lighting controls including installation, start-up, testing and documentation according to Construction Documents and Commissioning Plan (CxP).
2. Standard procedures for the execution of commissioning work shall be in conformance with Division 1, Section 01 91 00 General Commissioning Requirements. Coordinate all work with the Commissioning Agent (CxA).

1.8 RELATED SECTIONS:

9. Provisions of Division 01 apply to this section.
10. Section 01 91 00: Commissioning.
11. Section 01 78 23: Operations and Maintenance Data Training.
12. Section 26 05 00: Common Work Results for Electrical.
13. Section 26 05 01: Electrical General Provisions.
14. Section 26 09 23: Lighting Control Systems.
15. Section 26 50 00: Lighting Fixtures.
16. Project Commissioning Plan.

1.9 REFERENCES

- A. Applicable codes, standards, and references: all inspections and tests shall be in accordance with the following applicable codes and standards, except as provided otherwise herein:
14. National Electrical Testing Association – NETA.
 15. National Electrical manufacturer's Association – NEMA.
 16. American Society for Testing and Materials – ASTM.
 17. Institute of Electrical and Electronic Engineers – IEEE.
 18. American National Standards Institute – ANSI.
 19. National Electrical Safety Code – NESC.
 20. California Building Code – CBC.
 21. California Electrical Code – CEC.

22. Occupational Safety and Health Administration – OSHA.
23. National Institute of Standards and Technology – NIST.
24. ANSI/NFPA 70 – National Electrical Code.
25. NFPA 70E – Electrical Safety Requirements for Employee Work Places.
26. ANSI/NFPA 101– Life Safety Code.

1.10 SUBMITTALS

- B. Submittals shall include the following:
7. Submit required Cx submittals in accordance with Division 1 Specification Sections.
 8. Copy of the Architect’s reviewed and accepted submittals to the CxA via the OAR.
 9. List of team members who will represent the Contractor in the Pre-functional Equipment Checks and Functional Performance Testing, at least two (2) weeks prior to the start of Pre-functional Equipment Checks.
 10. Detailed manufacturer installation and start-up, operating, troubleshooting and maintenance procedures, checklist documentation and field checklist forms to be used by factory or field technicians, and a copy of full details of Owner-contracted tests, full factory testing reports, if any, and Warranty information, including responsibilities of Owner to keep Warranty in force, clearly defined.
 11. Detailed manufacturer’s recommended procedures and schedules for Pre-functional Equipment Checks, supplemented by Contractor’s specific procedures, and Pre-functional Tests, at least four (4) weeks prior to the start of Pre-functional Performance Tests.
 12. After facility’s commission is complete, submit all completed Pre-functional Equipment Checklists and Functional Performance Test checklists organized by system and by subsystem. Bind all information in a single package. The results of failed tests shall be included along with a description of the corrective actions taken.

1.11 MEETINGS, SEQUENCING AND SCHEDULING

- C. Meetings: Attend (Cx) meetings as required under Section 01 91 00 and the Cx Plan.
- D. Sequencing and Scheduling: The work described in this Section shall begin only after all work required in related Division 26 Sections has been successfully completed, and all tests, inspection reports and Operation & Maintenance manuals required in Division 26 Sections have been submitted and approved. The start-up and Pre-functional Equipment Checklists shall be completed and submitted to the Owner’s Authorized Representative (OAR) prior to the Functional Performance Tests. Refer to the project Cx Plan for more details.
1. Coordinate all electrical work with the work of other trades prior to scheduling of any Cx procedures.

2. Coordinate the completion of all electrical testing, inspection, and calibration prior to start of Cx activities.
3. Cx activities shall be scheduled in accordance with project's Cx plan.

1.12 QUALITY CONTROL

- B. Incorporate manufacturer's recommended Cx procedures for the systems and equipment to be commissioned under this Section.

PART 2 - PRODUCTS

2.2 TEST EQUIPMENT

- A. Equipment to be utilized in the commissioning process shall meet the following requirements:
 1. Provide test equipment as necessary for the equipment and systems to be commissioned.
 2. Provide testing equipment and accessories that are free of defects and certified for use.
 3. Provide testing equipment with current calibration labels per NIST Standards.
 4. All testing equipment shall be UL Listed.

PART 3 – EXECUTION

3.5 COMMISSIONING PROCESS REQUIREMENTS

- D. Work to be performed prior to commissioning:
 3. Complete all phases of the work so the system(s) can be started, tested, adjusted, balanced, and otherwise commissioned.
 4. If modifications or corrections to the installed systems are required to bring the system(s) to acceptance levels due to Contractor's incorrect installation or defective materials, such modifications or corrections shall be made at no additional cost to the Owner.
- E. Pre-commissioning Responsibilities: Inspection, calibration and testing of the equipment and apparatuses to commission the following systems:
 3. Electrical Lighting Systems.
 4. Lighting Controls.
- F. Commissioning Process Requirements:
 1. Refer to Section 019100 General Commissioning Requirements, related sections and Cx Plan for information on meetings, start-up plans, Pre-Functional and Functional Performance Testing (FPT), operations & maintenance data, and other Commissioning activities.

3.6 PREPARATION

- D. Provide certified electricians or other qualified personnel as required with tools and equipment necessary to perform all Cx activities.
- E. Provide equipment manufacturer's factory representative(s) for commissioning of classrooms lighting and its control system as required by the Cx Plan.
- F. Provide certified testing agency personnel and/or report(s) as required in the Cx Plan.

3.7 TESTING

- D. Testing documentation shall include the following minimum information:
 - 1. Test number.
 - 2. Equipment used for the test, with manufacturer and model number and date of last calibration.
 - 3. Date and time of the test.
 - 4. Indication of whether the record is the first commissioning test or a retest following correction of a previously identified problem or issue.
 - 5. Identification of the system, subsystem, assembly, or equipment.
 - 6. Conditions under which the test was conducted, including (as applicable) ambient conditions, set points, override conditions, and status and operating conditions that impact the results of the test.
 - 7. Systems and assemblies test results, performance and compliance with contract requirements.
 - 8. Issue number, if any, generated as the result of the test.
 - 9. Name and signature(s) of witnesses and the person(s) performing the test.
- E. Test lighting and controls systems performance to verify operation, functionality, light levels, energy usage, and compliance with construction documents.
 - 7. Contractor shall start up, test and document results under the observation of the CxA.
 - 8. Contractor shall execute the Functional Performance Test (FPT) under the observation of the CxA who will record the results of the Functional Performance Test procedures.
 - 9. Equipment & Components to be tested: Refer to Article 3.01, B.
 - 10. Functions and Testing Conditions:
 - g. Occupancy sensors and timer controls for lighting:
 - 1) Verify that all specified functions and features are set up, debugged and fully operable at time of test.
 - 2) Verify that occupant override feature functions properly and as intended in the contract documents.
 - 3) Verify that sensor durations are set properly.

- 4) Test the sequence of operation for all features and modes and confirm that adjustable timing matches the design specifications and contract documents.
- h. Electric lighting dimming, photocells and controls:
- 1) Test the dimming controls during daytime when conditions are such that controls should be dimming electric lighting. Verify that amperage changes in light fixtures are proportional to external light changes. Verify that dimmed light levels at the specified work plane remain within specified limits.
 - 2) Verify that delays and ramp times are set and functioning so that the speed of change of light fixture output is slow enough to not bother occupants and in compliance with the specifications.
 - 3) Verify that dimming does not cause lower than specified light levels in adjacent “non-dimmed” spaces.
 - 4) Verify that the controls and sensors cannot be easily overridden or disabled by occupants.
 - 5) Verify that dimming systems in places of assembly are interfaced with the Central Fire Alarm system. Dimmed lighting in these areas shall come back to full bright during a fire alarm condition.
- i. Illumination Levels, Night Conditions:
- 1) Verify that lighting throughout the building is operating automatically.
 - 2) Test with doors closed (to simulate actual occupancy) and after finishes are complete.
- j. Illumination Levels, Day Conditions:
- 1) Verify that lighting throughout the building is operating automatically.
 - 2) Test with doors closed (to simulate actual occupancy), after finishes are complete, and room is furnished.
 - 3) Test at different times during the day, or under Owner-approved simulated conditions, to ensure proper system response and to determine that lighting levels are within specified requirements.
 - 4) Test the system for the different pre-determined settings. AV mode, and normal standard class operation.
- k. Lighting Power Density: Perform the test with all interior lighting turned on and any manual or automatic controls temporarily overridden. The lighting power shall be measured at the building’s

electrical panels. Measurements shall be taken at least one (1) minute after all lighting in the building is on.

1. Emergency Lighting System: Verify that the system operates automatically under any condition, without human intervention, and that it resets back to normal operations after the power failure is over or cleared.
11. Acceptance Criteria:
- d. Lighting Controls: For the conditions, sequences and modes tested, the dimming/occupancy/photocell/timing controls, integral components and related equipment respond to changing conditions and parameters appropriately as defined in the Contract Documents.
 - e. Illumination Levels: Average light levels in the tested space at the work plane elevation shall not be less than 10% below nor greater than 20% above the specified light level range for the space.
 - f. Lighting Power Density: Average instantaneous lighting power density is +/- 10% of that indicated in the Construction Documents. Power factors on lighting circuits shall be 0.95, or as required by lighting fixture specifications.
12. Sampling Strategy for Identical Units:
- d. Lighting Controls: Test all automatic interior lighting controls.
 - e. Illumination Levels: At least 50% of all space zones and rooms, chosen by the Owner, shall be verified as realizing proper light levels. If 25% of the spaces in the first sample fail the Functional Performance Tests, test another 10% of the untested space zones and rooms (the 2nd sample). If 10% of the spaces in the 2nd sample fail, test all remaining spaces.
 - f. Power Density: Test all lighting circuits.
- F. Contractor shall participate and perform all Cx related testing requirements prescribed under Sections 019100 and the approved project Cx Plan.

3.8 ADJUSTING

- A. Systems improperly adjusted, incorrectly installed equipment and/or deficient Contractor performance may result in additional work being required for Cx acceptance.
 1. Contractor shall perform all work required to correct installations not meeting contract requirements at no additional cost to the Owner.
- B. Corrective work shall be completed in a timely manner to permit completion of the Cx process.
 1. Contractor shall refer to the Cx Plan for retesting requirements necessary to achieve required system performance.

2. If the systems' Cx deadline, as defined in the Cx Plan, goes beyond the scheduled completion of Commissioning without resolution of the problem, the Owner reserves the right to obtain supplementary services and/or equipment to resolve the problem.

END OF SECTION

SECTION 26 09 23
OCCUPANCY MOTION SENSORS

PART 1 - GENERAL

1.01 SCOPE

- A. Work Included: All labor, materials, appliances, tools, equipment necessary for and incidental to performing all operations in connection with furnishing, delivery and installation of the work of this Section, complete, as shown on the drawings and/or specified herein. Work includes, but is not necessarily limited to the following:
 - 1. Examine all other specification sections and drawings for related work required to be included as work under Division 26.
 - 2. General provisions and requirements for electrical work.

1.02 SUBMITTALS (ADDITIONAL REQUIREMENTS)

- A. Submit data sheets on sensors, wiring diagrams, relays, transformers, junction and outlet boxes, and mounting accessories. Submit wiring diagrams. Submit agency certifications /approvals.
- B. Submit details of pendant-mounted sensor installation.

1.03 APPLICABLE STANDARDS (ADDITIONAL REQUIREMENTS)

- A. General
 - 1. All ultrasonic sensors shall comply with the State of California Safety and Health Requirements. Decibel levels for ultrasonic sensors shall comply with the following criteria and the State of California Energy Commission for ultrasonic emissions:

MAXIMUM DECIBEL LEVELS FOR ULTRASONIC EMISSIONS	
Midfrequency of Sound Pressure Third-Octave Bank (kHz)	Minimum dB Level Within Third Octave Band (in dB reference 20 micropascals)
Less than 20	80
20 or more to less than 25	105
25 or more to less than 31.5	110
31.5 or more	115
 - 2. The CONTRACTOR and manufacturer shall certify in writing that all proposed and installed occupancy motion sensors comply with the Federal Environmental Protection Agency (EPA) and State of California Energy Commission criteria.
 - 3. Occupancy motion sensors shall be:
 - a. UL listed and labeled.
 - b. Certified for compliance with Federal-EPA and State of California Title-24 Energy Commission Requirements.

PART 2 - PRODUCTS

2.01 MOTION SENSORS

- A. General
 - 1. Motion sensors and power supply shall be self-contained. The motion sensors shall be solid state low voltage devices designed specifically for energy conservation lighting control. Combined dual function ultrasonic and infrared motion sensing.
 - a. Ultrasonic crystal controlled to within +/- 0.01% motion sensor technology.
 - b. Passive infrared (PIR) motion sensor technology.
 - 2. Occupancy motion sensor shall also include available ambient light sensor, in addition to the motion sensor. The ambient light sensor shall prevent the occupancy motion sensor

from automatically turning "on" the respective lighting when the ambient day-lighting intensity detected by photoelectric cell contained in the motion sensor exceeds a selected

intensity. The ambient light sensor circuit shall not control the automatic off function. The ambient lighting intensity detection sensitivity shall be adjustable in the sensor, adjustment range not less than 15 through 140 ambient day-lighting footcandles.

3. Automatic-off: sensor shall automatically turn "off" lighting when there is no movement after the preset time delay interval. Lights shall remain "on" with movement. There shall be a "dead band" time period after the unit turns itself off (because of lack of motion) during which a new motion will automatically turn lights on without the manual switch having to be activated.
4. Automatic-on: Sensor shall automatically turn "on" lighting when movement is detected in the monitored space. Lights shall remain on with movement. An internal control shall provide a mechanism to bypass the automatic-on control feature and allow only automatic-off functions. Where manual on/off [dimming] lighting control switches are shown on the drawings, in addition to the occupancy motion sensors in the same space, the manual controls shall override the automatic "on" control feature of the occupancy motion sensor. Override of the automatic "off" feature shall not be affected by the respective manual switches.
5. Motion detection sensitivity, time delays to turn "ON" after activation and time delays to turn "OFF, shall be adjustable to ensure there will be no nuisance on/off switching of the lights by the motion sensor while the room is occupied. Adjustable settings shall be tamper resistant, concealed behind an access protection cover.
 - a. Fluorescent light fixtures with Instant Start or Rapid Start lamp ballast, set the minimum lamp "on" time at not less than 15-minutes. Program Start lamp ballast, set the minimum lamp "on" time at not less than 5-minutes.
6. Automatic self-adjusting Adaptive-Learning for time delay and sensitivity variable conditions in the monitored space.
7. Fail-to-on, the failure of a sensor shall cause the occupancy motion sensor load relay contacts to activate, so the occupancy motion sensor function is automatically bypassed and lighting is turned-on.
8. All occupancy motion sensors shall be provided with an indicator light to display when motion is being detected and the unit is operating correctly.
9. Non-volatile internal memory shall store and maintain in memory all occupancy motion sensor settings during any electric power failure.
10. Where multiple occupancy motion sensors are installed with overlapping monitoring spaces, the sensors shall not cause false triggering or malfunctions to adjacent occupancy motion sensors.
11. Occupancy motion sensors shall incorporate mechanical vibration-damping. The vibration-damping shall prevent normal building vibrations from causing "false" sensor operation.
12. As manufactured by WattStopper; or Leviton; or Hubbell; or Greargate.

B. Area Control Coverage

1. Space coverage of motion sensor transponder shall remain constant after sensitivity control has been set. No automatic reduction/increase in coverage nor sensitivity shall occur when air motion caused by air conditioning or heating fans are in operation nor when the occupancy motion sensor has turned off lighting due to not detecting any motion.
2. Occupancy motion sensors in spaces 300 square feet area or less may be a wall switch mounted unit.
 - a. Wall switch sensors shall provide detection of motion at desk top, for up to 300 square feet, 180-degree range within a volume dimension of up to approximately 20-feet by 15-feet by 10-feet high, extending from the wall mounting height of the unit to the finish floor.
 - b. Wall switch occupancy motion sensors shall be a minimum load capacity of 500 watts 120V; 1000 watts 277V, but in no case shall the load rating be less than the lighting loads shown on the drawings.

3. Motion sensors in spaces exceeding 300 square feet in size and where shown on the drawing as mounted on the ceiling, shall be ceiling mounted. The sensor shall not protrude more than 1.6-inches below the ceiling line.
 - a. Sensor area coverage shall be 360 degrees three (3) dimensional diameter surrounding the sensor installation location.
 - b. The sensor shall be rated to provide coverage of the space volume/room length/width/height shown in the contract documents. Provide additional ceiling mounted motion sensors to provide complete coverage of each area.
 - c. Corridor/hallway sensor area coverage shall not be less than 80-foot linear feet extending from the sensor installation location. Sensor shall be bi-directional or uni-directional to provide complete area motion detection at the installation location shown on the drawings.

2.02 CONTROL UNITS

A. General

1. Control unit shall be an integrated, self-contained unit consisting internally of load switching control relay(s); internal power supply and power supply transformer. The power supply shall be sufficient capacity to provide low-voltage power to a minimum of two (2) motion sensors.
2. Occupancy motion sensors directly controlling line voltage electrical loads, the line voltage load relay contacts shall be "dry" type electrically isolated, with load ratings as follows:
 - a. 15A – 120 volt single phase 60Hz AC.
 - b. 15A – 277 volt single phase 60Hz AC.
3. Load relay contacts shall be rated to control load types up to the full ampere rating. Incandescent Tungsten lamps for lighting equipment. Rapid start and instant start and Program Start solid state electronic ballast (both low power factor and high power factor) for lighting equipment.
4. The quantity of individual internal load switching relays shall be not less than the quantity of individual "switchleg" circuits to be controlled shown on the drawings.

B. Occupancy Management control/Building Automation

1. Provide each occupancy motion sensor control unit with auxiliary dedicated single pole double throw relay contacts operated by the motion sensors that shall be interfaced with building Energy Management Control/Building Automation (EMCS/BAS) energy management and/or building security systems. Relay contacts serving security function shall activate when motion is detected, regardless of whether the respective room manual light switches are on or off.

C. Occupancy motion sensors that connect to low voltage remote control relays (LVR CR) systems.

1. LVR CR systems and occupancy motion sensor shall be rated and certified by the occupancy sensor manufacturer and the LVR CR manufacturer for proper operation with the LVR CR control port inputs and the occupancy motion sensor control output interface relay contacts. Occupancy sensor normally open, normally closed, maintained control relay contact, momentary control relay contact, control operation sequences in coordination with the LVR CR requirements for automatic "on and off" load control by the LVR CR.
2. The occupancy motion sensor power supply input, voltage rating and current rating control interface should comply with LVR CR requirements.

2.03 OCCUPANCY MOTION SENSOR HOUSING ENCLOSURE

A. General

1. Enclosures for occupancy motion sensor control units shall be pressed steel or high impact resistant nonflammable non-metallic enclosure. Enclosure finish color white. Semi-flush mounting installation, NEMA I "dead front" construction with mounting plates and barriers to provide separation between line voltage and low voltage wiring.

B. Mounting

1. Flush mounting 4.67-inches square by 2.125-inches deep outlet junction box with extension ring and occupancy motion sensor cover mounting plate.
2. Occupancy sensor shall be semi-flush mount into outlet box with tamper resistant attachment of the sensor and the outlet box.
3. Motion sensor shall be approved for installation in environmental air plenum.

PART 3 – EXECUTION

3.01 MOTION SENSOR QUANTITIES AND TYPES

A. General

1. The CONTRACTOR shall provide the quantity and types of motion sensors required for complete and proper volumetric coverage without gaps within the range of coverage(s) of controlled areas.
2. Rooms shall be 90% to 100% volumetric coverage of the sensing coverage area, to completely cover the controlled area to accommodate all occupancy habits of single or multiple occupants at any location within the room(s). Motion sensing detection coverage shall extend from the finish floor to not less than 48-inches above finish floor.
3. The locations and quantities of sensors shown on the drawings are diagrammatic and indicate only rooms, which are to be provided with sensors. The CONTRACTOR shall provide additional sensors if required to properly cover the respective rooms.
4. Ceiling mounted sensors shall also be pendant-mounted in rooms in which the controlled lighting fixtures are chain, cable or pendant suspension mounted. The mounting height of the sensor shall be approximately 6-inches below the bottom of the light fixtures to be controlled.
5. Wall mounted sensors shall be installed at a height not higher than the bottom of the respective ceiling lighting fixtures. For Wall switches with integrated manual switch for “on” or “off” applications, mounting height shall not exceed 42-inches above finish floor.
6. Occupancy sensors may be affected by various conditions in the room. Make adjustments, change the location and/or type of occupancy motion sensor to obtain proper operation in each specific room location.
7. Install occupancy motion sensors a minimum of 72-inches horizontal distance from environmental air supply/return registers, fans and moving objects.

3.02 SETUP AND TESTING

A. Commissioning (Additional Requirements)

1. Setup, testing, startup and commissioning shall be performed by factory technician(s) trained, certified and authorized by the equipment manufacturer. Final commissioning shall be performed after installation and connections are complete.
2. Provide system programming and setup of all control sequences for lighting control system.
3. Adjust sensitively, time-delay, location and orientation of each occupancy motion sensor; test each sensor/control unit all in accordance with the manufacturers recommendations. Be certain that no obstructions block proper sensor coverage of detection areas and limit sensor pickup zone to the respective room.
4. Test all control system functions after the installation and connections are complete and the system has been energized. Verify each control sequence of operation and each device to be controlled are operating correctly.
5. Verify interconnections and controls with the:
 - a. Lighting control systems.
 - b. Security/intrusion detection systems.
 - c. Building automation systems (BAS and energy management and control systems (EMCS).
6. Record and document each sensor setup and program setting.

7. Submit written report (3 copies) to District's Representative certifying commissioning has been performed; all respective systems are operating correctly and documenting all software setup and each device settings.

3.03 WIRING (ADDITIONAL REQUIREMENTS).

A. General

1. The drawings do not indicate the quantity of control wires required between various control points. The CONTRACTOR shall provide the quantity and type of control wire required for proper system operation, as recommended by the system manufacturer. Install all control circuits in conduit.
2. Control wire shall be copper #18AWG minimum, twisted pairs, PVC insulated for control voltage, color coded to match relay and switch wiring "pigtail" color codes.
3. Network communications wires shall be ANSI/EIA/TIA-568B, 100-OHM, 4-pair shielded twisted pairs STP, Category-5E.
4. Where multiple control wires are installed in a signal conduit or route to a single location provide multiconductor control cables with outer jacket. Control wires for control of relay controllers which shall be separate twisted shielded four wire PVC insulated conductors, with a ground wire and outer jacket for each controller to prevent "RF" inference.
5. Control wire shall be increased in wire gauge size as required to ensure proper system operation and voltage drop over the installation distance shown on the drawings between equipment and control device locations.
6. Occupancy motions sensor control power shall be powered from line voltage "hot" non-switched, lighting branch circuit. Alternately, control power may be obtained directly from the respective lighting control panel (if available). Provide two additional #12 (AWG) "hot-circuit" and neutral unswitched conductor in conduit homeruns and branch circuits.
7. All wiring shall be installed in conduit.

END OF SECTION

BRANCH CIRCUIT PANELBOARDS AND TERMINAL CABINETS

PART 1 - GENERAL

1.01 SCOPE

- A. Work Included: All labor, materials, appliances, tools, equipment necessary for and incidental to performing all operations in connection with furnishing, delivery and installation of the work of this Section, complete, as shown on the drawings and/or specified herein. Work includes, but is not necessarily limited to the following:
 - 1. Examine all other specification sections and drawings for related work required to be included as work under Division 26.
 - 2. General provisions and requirements for electrical work.

1.02 SUBMITTALS (ADDITIONAL REQUIREMENTS)

- A. Provide manufacturers catalog data for panels, cabinets, and circuit breakers.
- B. Provide Shop Drawing showing panel circuit arrangements, size, voltage, ampacity, overcurrent protective devices, etc.
- C. Provide nameplate engraving schedule.
- D. Short Circuit, Coordination and ARC-FLASH
 - 1. Perform and submit engineered settings for each equipment location, fuse and adjustable circuit breaker device, showing the correct time and settings to provide the selective coordination within the limits of the specified equipment, per the latest applicable standards of IEEE and ANSI. Provide electrical system short circuit fault analysis, both 3-phase line-to-line and 1-phase line-to-ground calculations as part of the coordination analysis recommendations. Provide Electric ARC-FLASH calculations as part of the coordination analysis recommendations.
 - 2. The information shall be submitted in both tabular form and on time current log-log graph paper, with an engineering narrative. Written narrative describing data, assumptions, analysis of results and prioritized recommendations, six (6) copies.
 - 3. The goal is to minimize an unexpected but necessary electrical system outage and personnel exposure to the smallest extent possible within the fault occurrence location, using the specified contract equipment. Shall comply with, but not limited to:
 - a. IEEE-242, Recommended Practices for Protection and Coordination of Industrial and Commercial Distribution.
 - b. IEEE-399, Recommended Practice for Industrial and Commercial Power System Analysis.
 - c. IEEE-1584, Guide to Performing ARC-FLASH Hazard Study.
 - d. CEC/NEC
 - 4. Electrical equipment including switchgear, switchboards, electrical panels, and control panels, transformers, disconnects, etc., shall each be labeled by the manufacturer with "Electrical-ARC-Flash" warning signs. The signs shall explain a hazard to personnel may exist if the equipment is worked on while energized or operated by personnel, to wear the correct protective equipment/clothing (PPE) when working "Live", or operating "Live" equipment and circuits.

1.03 SEISMIC EARTHQUAKE AND WIND LOADING WITHSTAND, TESTING AND CERTIFICATION. (ADDITIONAL REQUIREMENTS)

- A. General

1. The complete panels and terminal cabinet assemblies; including circuit protection devices, meter, housings/enclosures, accessories, supports/anchors etc., shall be designed, manufactured and tested.
 - a. Wind loading all outdoor equipment locations.
 - b. Earthquake seismic zone-4 and CBC/IBC Seismic withstand, all indoor and all outdoor equipment locations.
2. Shall withstand, survive and maintain continuous non-interrupted energized operation during the seismic event occurrences and wind event occurrences. Continued normal energized operation after the wind event and seismic event occurrences have abated.
3. Shall include demonstrations of successful operation and run test after completion of seismic event shake-table simulation. Acceptance test seismic qualification shall employ triple axis shake-table simulation of the Required Response Spectrum (RRS) seismic event motion, certified and approved by the AHJ.
4. Provide three (3) dimensional finite element analysis demonstrating anchorage and operational withstand of wind loading not less than as follows and as required by AHJ:
 - a. 100MPH – West coast states USA and Hawaii.
 - b. 150MPH – East coast states USA, Gulf coast states USA and Alaska state.
 - c. 90MPH – all other USA locations.
5. Seismic test shall be performed by a third party independent test laboratory. Wind analysis and seismic Testing and reports shall be certified, signed and “stamped” by PE Professional Engineer licensed and in good standing in the State, Civil Engineer or Structural Engineer.

PART 2 - PRODUCTS

2.01 PANELBOARDS AND DISTRIBUTION PANELS

- A. Shall be flush or surface mounting as indicated with group -mount circuit protection devices as shown on panel schedule, hinged lockable doors, index cardholders and proper bussing.
 1. Panelboards shall comply with the latest versions:
 - a. NEMA – PB1.
 - b. UL – 50 and 67.
 - c. CEC/NEC.
 - d. ASTM-B187.
 2. Where indicated on the drawings shall be furnished with subfeed breakers and/or additional conductor lugs, split bussing, contactors, time switches, relays, etc., as required.
 - a. Branch circuit panels up through forty-two (42) circuits shall be single section, to accommodate all of the circuits and components.
 - b. Distribution panels shall be single section or multi-section, to accommodate all of the circuits and components.
 3. Panels shall be “Service-Entrance” equipment rated when the panel main incoming supply feeder originates from one of the following:
 - a. Originates outdoors exterior of the building in which the respective panel is located.
 - b. Originates from an electrical supply source not located in the same building as the respective panel.
- B. Housing and Painting, Panels and Terminal Cabinets
 1. Shall be finished with one (1) coat of rust inhibitor zinc chromate and coat of primer sealer after a thorough cleaning.
 2. Finish color paint as selected by DISTRICT 's Representative where exposed to public view (e.g., corridors, covered passages, offices, etc.). Prime coated panelboard shall be painted to match surroundings after installation in public areas.
 3. Manufacturer's standard color in electrical rooms/closets, janitor's, HVAC and storage rooms.
 4. Shall be fabricated of sheet steel of the following minimum gauges.
 - a. Full height hinged, locking door. Trim #12 gauge steel; enclosure - code gauge steel.

- b. Panels installed in indoor dedicated electrical equipment rooms and dedicated electrical equipment closets, omit full height hinged locking panel door. Dead front cover behind omitted panel door shall remain.
 - 5. NEMA-1 Metal Housing, for indoor locations.
 - 6. NEMA-3R Metal Housing, tamper resistant, for outdoor locations.
 - 7. Furnish all panels and terminal cabinets with the manufacturers flush locks and keys except where indicated otherwise herein. Keys and locks shall be interchangeable for all panels. Provide two (2) latches and two (2) locks for door heights exceeding 36-inches.
 - 8. Fasten the trim to panel and terminal cabinets by means of concealed, bolted or screwed fasteners accessible only when the door is open.
- C. Panels 208/120 volt, three phase, 4-wire, S/N or 120/240 volt, single phase, 3-wire, S/N.
Branch circuit panel as manufactured by:
 - 1. Cutler Hammer "Pow-R-Line 1 or 2" Series
 - 2. General Electric "A" Series
 - 3. Square D "NF/NQ" Series
 - 4. Siemens "P1/P2" Series
- D. Branch circuit panels for 480/277 volt, three phase, 4 wire, S/N.
Panelboard as manufactured by:
 - 1. Cutler Hammer "Pow-R-Line 2" Series
 - 2. General Electric..... "A" Series
 - 3. Square D "NF" Series
 - 4. Siemens "P1/P2" Series
- E. Distribution panels as manufactured by:
 - 1. Cutler Hammer "Power-R-Line 3 or 4" Series
 - 2. General Electric "Spectra" Series
 - 3. Square D "I-Line" Series
 - 4. Siemens "P4/P5" Series
- F. Top and bottom gutter space shall not be less than 6-inches high. Provide 6-inches additional gutter space in all panels where double lugs are required, or where cable ampere size exceeds bus ampere size. Provide 12-inches additional gutter space in all panels for aluminum feeders where used.
- G. Panel dimensions.
 - 1. Panels with buss sizes 50 ampere thru 400 ampere
 - a. Shall be 20-inches wide. Surface or flush mounting as indicated.
 - b. Recess mounted type shall have a 20-inches wide (maximum) recess metal enclosure with overlapping edge trim plate cover extending 1-inch on all sides of enclosure.
 - c. Depth shall be 5.75-inches nominal. Height of panel as required for devices.
 - 2. Panels with buss sizes greater than 400 ampere
 - a. Narrow panels 24-inches (maximum) wide by 6.5-inches (maximum) deep units. Wide panels 25-inches to 44-inches (maximum) wide by 8-inches to 15-inches (maximum) deep units. Nominal 90-inch panel height.
 - b. The wider units shall be used only at locations where the narrow unit is not available with the quantity or size of large-ampere frame branch/subfeed circuit protective devices shown on the panel schedules, or where the main breaker size exceeds the narrow panel maximum.
 - c. Distribution panels shall be floor standing and also supported from behind the panels at walls.
- H. Distribution panels and branch circuit panels maximum load rating
 - 1. Panelboards and Distribution Panels exceeding 800-ampere load rating shall not be permitted.
 - 2. Provide Distribution Switchboards instead of Distribution Panels for bus load and circuit load ratings exceeding 800 ampere.

- I. Panel Auxiliary Cabinets
 - 1. Panelboards shown on the drawings with relays, time clocks or other control devices shall have a separate auxiliary metal barriered compartment mounted above panel.
 - 2. Panelboards with circuits controlled by low voltage remote control relays shall be provided with separate auxiliary cabinets to contain the relays, adjacent to the panelboard.
 - 3. Provide auxiliary cabinets with separate hinged locking door to match panelboard.
 - 4. Provide mounting subbase in cabinet for control devices and wiring terminal strips.
- J. Panels shall have a circuit index cardholder removable type, with clear plastic cover. Index card shall have circuit numbers imprinted to match circuit breaker numbers.
 - 1. The panel identification nameplate shall describe the respective panel name and voltage, corresponding to the contract documents.
 - 2. The electrical power source, name and location of each panel supply-feeder and supply equipment name shall also be identified and described on the respective panel nameplate.
- K. TVSS - Transient Voltage Surge Suppressor
 - 1. Provide each of the following branch circuit panel and distribution panel types with a TVSS and RF filtering:
 - a. 208/120 volt - single phase and/or three phase.
 - b. 120/240 volt - single phase.
 - c. 480/277 volt - single phase and/or three phase.
 - d. All distribution panels.
 - 2. The TVSS shall be installed inside the respective panel housing and shall be factory connected to each main phase, ground and neutral bus inside the panel.
 - 3. The TVSS monitor/annunciator indicators shall be visible only when the panel access door is in the open position.
 - 4. Provide a 20-ampere 3-pole (2-pole for single-phase panels) branch circuit protection device in each panel for TVSS connection.
 - 5. The TVSS device and panel shall be UL labeled and listed for combined use. See related specification sections for additional TVSS requirements.
- L. Seismic Earthquake and wind loading withstand, testing and certification (ADDITIONAL REQUIREMENTS)
 - 1. The complete panel/panelboard assembly; including circuit protection devices, housings/enclosures, accessories, supports/anchors etc., shall be designed, manufactured and tested for wind loading and earthquake seismic zone-4 withstand.
 - 2. Shall withstand, survive and maintain continuous non-interrupted energized operation (running) during the seismic event occurrences. Continued normal energized operation after the wind event and seismic event occurrences have abated.
 - 3. Shall include demonstrations of successful operation and run test after completion of seismic event shake-table simulation.
 - 4. Provide three (3) dimensional finite element analysis demonstrating anchorage and operational withstand of wind loading as follows:
 - a. 100MPH – West coast states USA and Hawaii.
 - b. 150MPH – East coast states USA, Gulf coast states USA and Alaska state.
 - c. 90MPH – all other USA locations.
 - 5. Acceptance test seismic qualification of proposed panels and panelboards shall employ triple axis shake-table simulation of the Required Response Spectrum (RRS) seismic event motion, certified and approved by the AHJ.
 - 6. Seismic test shall be performed by a third party independent test laboratory. Wind analysis and seismic Testing and reports shall be certified, signed and "stamped" by PE Professional Engineer licensed and in good standing in the State, Civil Engineer or Structural Engineer.

2.02 Short Circuit Rating

- A. Circuit protective devices and bussing as indicated on the drawings. All devices and bussing shall have a short circuit fault withstand and interrupting capacity not less than the maximum available fault current at the panel and as indicated on the drawings, plus a 25% additional capacity (safety margin). However, in no case shall the short circuit fault interrupting and withstand capacity be less than the following symmetrical short circuit.

<u>C/B and/or Bus Rating</u>	<u>Circuit Voltage</u>	<u>Short Circuit Amp.</u>
1. 400A and less	240V and below	10,000A
2. 400A and less	over 240V and below 600V	14,000A
3. Over 400A & 800A & below	240V and below	42,000A
4. Over 400A & 800A & below	over 240V and below 600V	30,000A

- B. Panel short circuit fault rating

1. General

- a. Provide a “fully rated” for short circuit fault interrupt and full load ampere main circuit breaker in each branch circuit panel and/or each distribution panel. Provide the main circuit breaker whether or not a main circuit breaker is shown otherwise on the drawings, schedules or diagrams. The “utility-source” plus the “motor-load” transient contributions shall be used to establish the available fault duty values, unless indicated otherwise on the drawings.
- b. The panel main circuit breaker full load ampere capacity rating shall equal the respective panel main bus ampere rating.
- c. The panel assembly, buss and circuit protection devices bolted fault short circuit withstand and bolted fault short circuit interrupt ratings shall not be less than 125% greater (including a 25% safety margin) than the available utility-source symmetrical and asymmetrical bolted fault short circuit current when “series combined rated” with the panel main circuit breaker.
- d. The main circuit breaker rated “bolted-fault” short circuit fault interrupt and withstand short circuit rating shall not be less than 125% (including a 25% safety margin) of the upstream main service entrance “bolted-fault” available (symmetrical and asymmetrical) short circuit current.

2. Distribution Panelboards

- a. Distribution panel, main circuit breaker, all feeder circuit breakers, and all branch circuit breakers shall be “fully-rated” (plus safety margin) for the available bolted fault short circuit current (including safety margin).
- b. Shall provide time/current-tripping coordination with downstream equipment and upstream equipment.

3. Non-emergency branch circuit panelboards 400-ampere buss and smaller; Non-emergency branch circuit panelboards 400-ampere trip main circuit breaker and smaller.

- a. The branch circuit panel main circuit breaker shall be “fully-rated” (plus safety margin) Current Limiting Circuit Breaker type (CLCB). Shall provide time/current- tripping coordination with upstream equipment.
- b. The branch circuit panel main circuit breaker shall be “series-rated” with the panel downstream branch circuit devices and panel bussing. “The series-rating” shall provide short circuit bolted fault current withstand protection and short circuit bolted fault interrupt rating protection during a downstream 3-phase line-to-line and/or single-phase line-to-ground short circuit bolted faults.
- c. Typical for branch circuit panelboards connected to normal-power (non-emergency) power circuits.

4. Emergency branch circuit panelboards 400-ampere bus and smaller; Emergency branch circuit panelboards 400-ampere trip main circuit breaker and smaller.

- a. The branch circuit panel main circuit breaker shall be short circuit bolted fault “fully-rated” (plus safety margin) non-Current Limiting circuit breaker type (non-CLCB).
- b. The panel bussing shall also be short circuit bolted fault “fully-rated”.

- c. All of the branch circuit panel, branch circuit breakers shall be “fully-rated” non-fused Current Limiting Circuit Breaker Type (CLCB). Shall provide short circuit bolted fault interrupt rating. Coordinated time/current and instantaneous tripping with the upstream circuit protection devices.
- d. Typical for branch circuit panelboards connected to emergency power circuits.

2.03 PANEL CIRCUIT BREAKERS, CIRCUIT PROTECTION DEVICES

- A. Circuit Breakers General, for Distribution Panels and Panelboards
 - 1. NEMA-AB1 and AB3, comply with latest revision.
 - 2. UL-1087, UL-489 and IEC-60.947.2 rated devices, comply with latest revision.
 - 3. 5Hz AC closing and 3Hz AC trip and clear.
 - 4. Main circuit breakers for distribution panels exceeding 400 ampere and larger;
 - a. Shall be Insulated Case Circuit Breaker type ICCB.
 - 5. Main circuit breakers for branch circuit panelboards 400 ampere buss and smaller;
 - a. Shall be Current Limiting Circuit Breaker type-CLCB for non-emergency panelboards.
 - b. Shall be Molded Case Circuit Breaker type-MCCB for emergency panelboards.
 - 6. Branch circuit breakers and feeder circuit breakers smaller than 100-ampere trip shall be Molded Case Circuit Breakers type-MCCB and/or Current Limiting Circuit Breakers type-CLCB.
 - 7. All circuit breakers 100 ampere and larger trip shall employ sensors and solid state digital electronic automatic trip system. Short-time and long-time Time/current curve shaping field adjustable functions and adjustable instantaneous trip. Typical for Molded Case Circuit Breaker type-MCCB, Insulated Case Circuit Breaker type-ICCB and Current Limiting Circuit Breaker type-CLCB.
 - 8. Refer to Specification Section 16425 and/or 16312 for additional circuit breaker requirements.
- B. Manufacturer
 - 1. Circuit breakers as manufactured by the following companies only are acceptable:
 - a. Cutler Hammer
 - b. General Electric Co.
 - c. Square D Co.
 - d. Siemens
- C. Configuration
 - 1. Circuit breakers shall be arranged in the panels so that the breakers of the proper trip settings and numbers correspond to the numbering in the panel schedules on the drawings.
 - 2. Circuit numbers of breakers shall be black-on-white micarta tabs or other previously approved method. Circuit number tabs, which can readily be changed from front of panel, will not be accepted. Circuit number tabs shall not be attached to or be a part of the breaker.
 - 3. Panelboard circuit protection devices shall be bolt on type for connection to panel bus. Removable and installable without disturbing adjacent devices.
 - 4. Provide conductor wire terminations (lugs) on each circuit protection device for incoming main feeder, branch circuits and outgoing feeder circuits. Dual rated copper/aluminum and compatible with the respective conductor size, type, and quantity.
 - 5. Where 2-pole or 3-pole breakers occur in the panels, they shall be common trip units. Single pole breakers with tie-bar between handles will not be accepted.
 - 6. Branch circuit panels shall be field convertible for bottom entry main incoming feeder or top entry main incoming feeder.
 - 7. Each panel section, the feeder and branch circuit protection devices (3-phase and/or 1-phase) shall be “twin-mount”, side-by-side double row construction for the following circuit sizes:
 - a. 480/277 volt, 60-ampere circuit size and smaller.
 - b. 240 volt – 208/120 volt, 100 ampere circuit size and smaller.

- D. Lock-Off and Lock-On
 - 1. All circuit breakers shall be pad-lockable in the "off" position.
 - 2. Where branch circuit breakers supply the power to motors and signal systems, the breakers shall also be furnished with lockout clips, mounted in the "on" position. The breakers shall be able to trip automatically with lockout clips in place.
 - 3. Provide lock-on clips on branch circuit breakers supplying fire alarm equipment and fire alarm panels. Provide identification of the dedicated "fire alarm" circuit function and operation. Color-code the circuit breakers to comply with AHJ requirements.
 - 4. Locking facilities shall be riveted or mechanically attached to the circuit breaker (submit sample for approval. Other means of attachment shall not be accepted without prior written approval of the District's Representative.

- E. ARC Fault Interrupter Circuit Breaker (AFCI-C/B)
 - 1. AFCI-C/B provides automatic circuit interruption upon detection of any of these conditions: overload, short circuit fault and electric branch circuit arcing protection.
 - 2. The AFCI-C/B shall detect intermittent "arcing" type electrical faults, and provide automatic circuit interruption (tripping).
 - 3. Provide "test-pushbutton" on each C/B for manual AFCI-C/B testing.
 - 4. Single pole, 120-volt, 60Hz AC UL listed and labeled for installation in panelboard, #14 - #8AWG solid/ stranded AL/CU load conductor.

- F. Switch and Fuse Feeder Protective Devices for Distribution Panels
 - 1. Locations where the drawings show distribution panels employing switch-fuse circuit protection devices.
 - 2. Fusible Switches: Quick-make, quick-break type with rejection clips for use with Class "R" fuses current limiting fuses (CLF). Switches with ratings up to and including 100 ampere at 240 volts shall be twins mounted. Switches rated through 60 ampere and 480 volts shall be twins mounted. Provisions for padlocking in the "on" and/or "off" positions. Switches shall be removable from front of panel without disturbing adjacent units or panel bus structure.
 - 3. Fuses shall be time delay current limiting types, UL Class RK-1 unless otherwise indicated on the drawings. Provide one (1) spare set of fuses of each size and type in each Distribution Panel.
 - 4. Provide auxiliary contact on switch for remote status (on-off) signaling and monitoring. Provide conductor lugs to accept conductor temperature rating, sizes and quantities shown on drawings.
 - 5. Switch and fuse devices shall be permitted only in distribution panels and only where specifically indicated on the drawings for feeders.

2.04 PANEL BUSSING

- A. Bus Material
 - 1. Bussing shall be rectangular cross section tin-plated copper or alternately silver or tin-plated aluminum.
 - 2. Bussing shall be non-tapped, full length of the enclosure.

- B. Ground Bus
 - 1. Each panel shall be equipped with a ground bus secured to the interior of the enclosure. The bus shall have a separate lug for each ground conductor. No more than one conductor shall be installed per lug.

- C. Provisions
 - 1. Provide space and all hardware and bus mounting attachments for future devices as indicated on the drawings.

D. Neutral Bus

1. The ampere rating of the neutral bus of panels and distribution panels shall be a minimum of 100% greater ampere capacity than the ampere rating of the corresponding phase bus, where the panel is indicated to be provided with an "oversize-neutral" or "200%" neutral on the drawings.

2.05 TERMINAL and AUXILIARY CABINETS

A. Cabinets

1. Fabricated of code gauge sheet steel for flush mounting (except where noted as surface) of size indicated on the drawings, and complete with hinged lockable doors, provide the quantity of 2-way Feed through conductor terminals required for termination of all conductors, plus 15% spares of each type.
2. Cabinet locks to operate from same key used for panelboards. The trim to cabinets shall be fastened by means of concealed bolted or screwed fasteners accessible behind door into cabinets. All cabinets shall have 5/8-inch plywood backing, finished with fireproof intumescent primer and finish coat paint. Provide equipment ground bus in each cabinet.
3. Cabinets shall be finished with one coat of zinc chromate and one coat of primer sealer after a thorough cleaning. Where exposed to public view (e.g., corridors, covered passages, offices, etc.) finish color paint to match surrounding and manufacture's standard gray color in switchboard, janitors, heater and storage rooms.
4. Provide grounded metal barriers inside cabinet to isolate and separate line voltage and low voltage from each other inside the cabinet.

B. Cabinet dimensions.

1. Unless indicated otherwise on drawings.
 - a. Shall be 20-inches wide. Surface or flush mounting as indicated.
 - b. Recess mounted type shall have a 20-inches wide (maximum) recess metal enclosure with overlapping edge trim plate cover extending 1-inch on all sides of enclosure.
2. Depth shall be 5.75-inches nominal. Height of cabinet as required for devices, plus 25% spare unused interior space for future use, but not less than 36-inches high.

C. Terminals

1. Non-digital analog circuits; line and low voltage modular signal systems, 15-ampere dual row with isolation barriers, screw-down terminals insulated strips, heavy duty.
 - a. As manufactured by Molex, or ITT-Cannon, or General Electric.
2. Digital circuits; low voltage signal systems, ANSI/ EIA/TIA Category-6, 110-Block or 66-Block gas-tight punch down style, heavy duty.
 - a. As manufactured by: Leviton, or Ortronics, or AMP.

D. Identification (additional requirements)

1. Provide engraved nameplate on each cabinet indicating its designation and system (i.e., "Life Safety System - Panel 2LS", etc.).
2. Identify each terminal landing with unique circuit number and provide corresponding alphanumeric text-index card inside panel access door

PART 3 - EXECUTION

3.01 MOUNTING

A. Flush mounted panelboards and terminal cabinets shall be securely fastened to at least two studs or structural members. Trim shall be flush with finished surface.

1. Panels and cabinets installed flush (recess or semi-recess) into fire rated or smoke rated walls. The wall recess shall be fully wrapped inside the recess with fire/smoke rated materials. The wrap-materials shall provide the same fire and/or smoke protection rating as the respective wall.

- B. Surface mounted panels and terminal cabinets shall be secured to walls by means of preformed galvanized steel channels securely fastened to at least two (2) studs or structural members.
- C. Panelboards and terminal cabinets shall be installed to insure the top circuit protective device (including top compartment control devices) are not more than 6-feet-6-inches above finish floor in front of the panel and the bottom device is a minimum of 12-inches above the floor. Manufacturer shall specifically indicate on shop drawing submittals each panel where these conditions can not be met.

3.02 IDENTIFICATION (ADDITIONAL REQUIREMENTS)

- A. Provide a red and white Bakelite nameplate with ½-inch high letters in each 277/480 volt panel fastened to face of dead-front plate, to read: "DANGER 480 (or as applicable) VOLTS KEEP OUT AUTHORIZED PERSONNEL ONLY".
- B. Manufacturer shall stencil the panel/cabinet number identification on the inside of door to correspond with the designation on the drawings.
- C. Identification plates and numbers shall be attached with screws or twist lock fasteners. Adhesive attachment of any kind shall not be used.

3.03 SPARE CONDUITS (ADDITIONAL REQUIREMENTS)

Provide three (3) 1-inch conduit only stubs from each panel and terminal cabinet into accessible ceiling space. Where floor level below panel or terminal cabinet is accessible, also provide an additional three (3) 2-inch conduit only stubs into accessible floor space.

END OF SECTION

SECTION 26 24 19
MOTOR CONTROL EQUIPMENT

PART 1 - GENERAL

1.01 SCOPE

- A. Work Included: All labor, materials, appliances, tools, equipment necessary for, and incidental to, performing all operations in connection with furnishing, delivery and installation of the work of this Section, complete, as shown on the drawings and/or specified herein. Work includes, but is not necessarily limited to the following:
1. Examine all other specification sections and drawings for related work required to be included as work under Division 26.
 2. General provisions and requirements for electrical work.

1.02 SUBMITTALS (ADDITIONAL REQUIREMENTS)

- A. Provide schematic "ladder-type" logic control wiring diagrams and "point-to-point" control wiring diagrams showing the control system for HV/AC equipment and other electrical equipment.
- B. Provide nameplate engraving schedule.
- C. Submit full-scale time/current transparencies on log/log paper for all fuses, circuit breakers, ground fault system devices, and relays.
- D. SHORT CIRCUIT, COORDINATION AND ARC-FLASH
 1. Perform and submit engineered settings for each equipment location, fuse and adjustable circuit breaker device, showing the correct time and current settings to provide the coordination within the limits of the specified equipment, per the latest applicable standards of IEEE and ANSI. Provide electrical system short circuit fault analysis, both 3-phase line-to-line and 1-phase line-to-ground calculations as part of the coordination analysis recommendations. Provide Electric ARC-FLASH calculations as part of the coordination analysis recommendations.
 2. The information shall be submitted in both tabular form and on time current log-log graph paper, with an engineering narrative. Written narrative describing data, assumptions, analysis of results and prioritized recommendations, six (6) copies.
 3. The goal is to minimize an unexpected but necessary electrical system outage and personnel exposure to the smallest extent possible within the fault occurrence location, using the specified contract equipment. Shall comply with, but not limited to:
 - a. IEEE-242, Recommended Practices for Protection and Coordination of Industrial and Commercial Distribution.
 - b. IEEE-399, Recommended Practice for Industrial and Commercial Power System Analysis.
 - c. IEEE-1584, Guide to Performing ARC-FLASH Hazard Study.
 - d. CEC/NEC
 4. Electrical equipment including switchgear, switchboards, electric panels and control panels, motor control centers, combination motor starters, transformers, disconnects, etc., shall each be labeled by the manufacturer with "Electrical-ARC-Flash" warning signs. The signs shall explain a hazard to personnel may exist if the equipment is worked on while energized or operated by personnel while energized. The sign shall instruct personnel to wear the correct protective equipment/clothing (PPE) when working "Live", or operating "Live" electrical equipment and circuits.

PART 2 - PRODUCTS

2.01 GENERAL

- A. Division 240000 HVAC/Plumbing
Refer to Division 260000 Mechanical and Plumbing Contract Documents and shop drawings for additional electrical work and material requirements.
 1. Provide all control devices including timeswitches, relays, auxiliary contacts, voltage transformers, and interlocks.
 2. Provide all raceways, conduit wire, circuits, outlets, and interconnections of starters as required for HVAC and Plumbing systems.
- B. Special Considerations
 1. Mount all auxiliary relays and timeswitches in an isolated compartment inside motor control equipment unless otherwise indicated.
 2. Whether or not shown on mechanical and plumbing Contract Documents and/or control schedules, where motors are controlled by external devices (i.e., thermostats, relays, float or pressure switches, etc.) or interlocked with other motors, provide each magnetic motor starter with a "Hand-Off-Auto" selector switch in starter cover. Other magnetic motor starters provide a "Start-Stop" push-button station in starter cover.
 3. Motor starters, motor controllers and circuit feeder tap devices for motor circuits shall be rated and labeled for control of all electric motor design types A, B, C, D, and E pursuant to the requirements of the NEC
- C. Seismic Earthquake and wind loading withstand, testing and certification (ADDITIONAL REQUIREMENTS)
 1. The complete motor control equipment assembly; including circuit protection devices, motor controllers, housings/enclosures, accessories, supports/anchors etc., shall be designed, manufactured and tested.
 - a. Wind loading for outdoor locations.
 - b. Earthquake seismic zone-4 withstand and CBC/IBC Seismic withstand, all indoor and all outdoor equipment locations.
 2. Shall withstand, survive and maintain continuous non-interrupted energized operation (running) during the seismic event occurrences. Continued normal energized operation after the wind event and seismic event occurrences have abated.
 3. Shall include demonstrations of successful operation and run test after completion of seismic event shake-table simulation.
 4. Provide three (3) dimensional finite element analysis demonstrating anchorage and operational withstand of wind loading not less than as follows and as required by AHJ:
 - a. 100MPH-West coast states USA and Hawaii.
 - b. 150MPH-East coast states USA, Gulf coast states USA and Alaska state.
 - c. 90MPH-all other USA locations.
 5. Acceptance test seismic qualification of proposed motor control equipment shall employ triple axis shake-table simulation of the Required Response Spectrum (RRS) seismic event motion, certified and approved by the AHJ.
 6. Seismic test shall be performed by a third party independent test laboratory. Wind analysis and seismic Testing and reports shall be certified, signed and "stamped" by PE Professional Engineer licensed and in good standing in the State, Civil Engineer or Structural Engineer.
- D. Motor control equipment as manufactured by:
 1. General Electric; or Square D; or Cutler-Hammer; or Allen-Bradley; or Siemens.

2.02 MANUAL MOTOR STARTERS

- A. Provide flush or surface mounting manual motor starters with number of poles and size of thermal overload heaters as required for the motor being controlled (equipped with overload

heaters, one (1) for each motor lead). Back boxes shall be supplied with all flush mounting starters, whether they are toggle type requiring only a 4-inch square outlet box or the larger type requiring a special box. Provide cover designed to accept the particular unit.

- B. Unless otherwise noted on the drawings, all manual starters for single phase motors, smaller than 1 h.p. shall be the compact toggle type. Manual starters for all single phase motors, 1 to 5 h.p. and all three phase motors up to 5 h.p. shall be the heavy-duty type.
- C. Where manual motor starter is shown with pilot light, the pilot light shall be installed in a separate outlet box adjacent to the starter outlet with engraved nameplate to indicate function of pilot light. Pilot lights shall be push-to-test style.

2.03 FEEDER TAP DEVICES

A. General

1. Feeder tap devices shall be coordinated with the motor starter unit's electrical and mechanical characteristics. Operating handle shall be accessible and operable from the unit front with positive visible indication of the on, off and tripped operating handle positions.
2. Feeder tap devices shall have a short circuit and motor locked rotor interrupting capacity, series rated with the respective motor starter of not less than the maximum available fault current at the device as indicated on the drawings, but in no case shall the interrupting capacity be less than 30,000 ampere symmetrical interrupting for 480/277 volt devices and 42,000 ampere symmetrical for 240 volt or 208/120 volt devices. Provide four key interlocking and padlock-off devices on each feeder tap unit.
3. Feeder tap device (i.e. circuit breakers, switch and fuse or motor circuit protector) shall be as indicated on the drawings. Where feeder tap device type is not indicated, provide switch and fuse type device.
4. Circuit breakers shall provide time overcurrent and instantaneous circuit protection. Motor circuit protectors shall provide instantaneous magnetic only circuit protection. Feeder tap devices shall be UL component listed and rated with the respective motor starters.
5. Feeder tap device shall provide an auxiliary contact to automatically connect and disconnect control power when the feeder tap device is open, tripped or closed.
6. Provide an auxiliary contact on feeder tap device for remote status (on-off) signaling and monitoring.
7. Provide conductor lugs to accept conductor temperature rating, sizes, and quantities shown on the drawings.

B. Feeder tap devices shall be as indicated on the drawings:

1. Circuit breaker feeder tap
 - a. Circuit breakers shall employ a stored energy, quick make-quick break, and trip free operating system on each phase, with common trip. Breakers shall comply with U.L. 489 and 1087, NEMA AB1 AB3 latest revisions. Circuit breakers noted as "100%" on the drawings shall be rated to carry the breaker full rated (100%) ampere load continuously.
 - b. Protection performance requirements for circuit breakers conforming to one or more of the following applications:
 - 600 Ampere or larger frame size.
 - Larger than 400 ampere trip.
 - Service entrance motor control center.
 - Noted as main circuit breakers on the drawings.
- 1) Circuit breaker shall employ current sensors and solid state static digital electronic automatic trip system. Three phase, or single-phase operation as noted on the drawings. Current carrying components shall be completely isolated from the static trip units. The trip unit shall be independent of external power sources. Circuit breaker shall be U.L. listed for reverse connection.

- 2) Circuit breaker solid state trip control functions shall provide the following time/ current curve shaping field adjustable features;
 - a) Adjustable ampere setting to vary the long-time continuous current carrying capacity, minimum range of 80% through 100% of full load trip rating.
 - b) Adjustable long-time delay setting to vary the time the breaker will trip under sustained overload conditions. Minimum of three settings, "minimum - intermediate - maximum".
 - c) Adjustable short-time pickup to vary the level of high current the breaker can carry for short periods of time, minimum range of 2 times through 8 times of ampere setting.
 - d) Adjustable short time delay to vary the time of the short-time pickup. Minimum of three settings "minimum-intermediate-maximum".
 - e) Short time " I^2t " switch to allow a current-squared multiplied by time ramp function in the short-time system. Two (2) position setting "in-out".
 - f) Adjustable instantaneous pickup to vary the breaker ampere setting for immediate (instantaneous) interruption of severe overloads (short circuits). Adjustable minimum range of 2.0 times through 13 times of circuit breaker ampere sensor rating. Circuit breaker shall incorporate adjustable instantaneous trip settings to allow coordinated instantaneous trip settings when protecting energy efficient motors.
 - g) Individual fault trip indicators shall provide local indication on the breaker for overload and short circuit (and ground fault where applicable) conditions.
 - h) Provide one manufacturer standard test set for solid state trip circuit breakers.
- c. Protection performance requirements for circuit breakers conforming to one or more of the following applications:
 - Smaller than 600 ampere frame size.
 - 400 ampere and smaller trip.
 - Larger than 100 ampere frame size.
 - Larger than 100 ampere trip.
 - 1) Circuit breaker shall employ current sensors and solid-state static digital electronic automatic trip system. Time/current curve shaping field adjustable features.
 - 2) Solid state trip breakers shall conform to the requirements described above for solid state breakers larger than 400 ampere trip. However, only the following field adjustments are required;
 - a) Ampere setting adjustable minimum range of 80% through 100% of full load trip rating.
 - b) Short time pickup adjustable minimum range of 2 times through 8 times of the ampere setting.
 - c) Adjustable instantaneous trip (circuit breaker shall incorporate adjustable instantaneous trip settings to allow coordinated instantaneous trip settings when protecting energy efficient motors).
- d. Performance requirements for circuit breakers conforming to the following applications:
 - 100 ampere frame size and smaller.
 - 100 ampere and smaller trip.
 - 1) Circuit breaker shall be fixed or adjustable instantaneous trip with thermal-magnetic trip or with solid-state static digital electronic automatic time/over current automatic trip depending on the results of the coordination study.
- e. Current Limiting Circuit Breakers (CLCB):
 - 1) Performance requirements for circuit breakers conforming to the following applications:
 - 600 ampere and smaller trip and identified as current limiting (CLCB) on the drawings.
 - a) Current limiting circuit breakers shall be supplied in unit molded case construction and shall consist of a common trip, thermal-magnetic or solid state

- trip circuit breaker with an independently operating limiter section in series with each pole.
- b) The conventional breaker section shall have an over center, trip-free, toggle-type mechanism with quick-make, quick-break action and positive handle indication. A button shall be provided on the cover for mechanically tripping the circuit breaker. The current limiting breaker shall have permanent trip units containing solid state static digital trip or individual thermal and magnetic trip elements in each pole. Calibrated for 40 degrees C ambient temperature. The limiter section shall consist of three current limiting elements electrically coordinated with the conventional circuit breaker trip elements. The contacts of the limiter section shall be electro-magnetically and electro-dynamically opened and held open until interruption is complete.
 - c) Current and Energy Limitations: On high-level fault currents the limiter portion of the circuit breaker shall operate to limit the rise of fault current. Integral resistance shall be introduced into the faulted circuit to dissipate and limit let-through energy and to provide a voltage transient-free interruption at near unity power factor. The Let-through short circuit fault current and energy levels shall be less than that permitted by Underwriters Laboratories to a Value less than I^2t of a half cycle wave of the symmetrical prospective current. The CLCB limiter shall limit the Asymmetrical short circuit fault current below the equipment symmetrical short circuit fault current.
 - d) On fault currents below the threshold of current limitation, the thermal-magnetic breaker section shall provide conventional overload and short circuit protection.
- 2) Performance requirements for circuit breakers conforming to the following applications:
- Trip ratings over 600 ampere. Identified as current limiting (CLCB) on the drawings.
- a) Integrally fused circuit breaker integrated with solid state static digital electronic automatic trip. Combined standard circuit breaker providing overload-short circuit protection within its interrupting capacity and ON-OFF switching function and on each phase current limiters internally mounted on the load side of the circuit breaker, of such ratings that their time current limiting characteristics will coordinate with the time current tripping characteristics of the circuit breaker elements.
 - b) The coordination shall result in the interruption by the circuit breaker alone of fault level currents up to the interrupting capacity of the circuit breaker and interruption by the current limiter in conjunction with the circuit breaker of fault level currents above the interrupting capacity of the circuit breaker.
 - c) A removable cover shall be provided over the current limiter section of the integrally fused circuit breaker. The current limiter housing covers shall be interlocked with the breaker tripping mechanism to insure the breaker will trip upon removal of the cover. The cover shall be interlocked with the breaker to insure the circuit breaker cannot be turned to the ON position with the cover removed. Current limiters shall have a spring loaded plunger which, when the limiter blows, is released to actuate the circuit breaker common trip bar mechanism opening all breaker poles simultaneously.
 - d) The limiters shall be individually interlocked with the breaker element tripping mechanism to insure the limiter cannot be inserted until the breaker is in the OFF position. The circuit breaker and limiters shall be interlocked to insure the circuit breaker cannot be closed if a limiter is either missing or has blown.
 - e) Fuse limiters shall be individually removable from the circuit breaker housing.
 - f) The circuit breaker shall be ambient temperature compensating. The circuit breaker shall be provided with thermal magnetic or solid state static digital trip (depending on the coordination study).

- g) The integrally fused circuit breaker shall be capable of interrupting available short circuit currents up to 200,000 RMS symmetrical amperes at voltage up to 600 VAC.
 - h) Ratings, clearances and performance of the integrally fused circuit breaker shall be in accordance with applicable standards of NEMA, IEEE and ASA.
2. Switch and fuse feeder tap:
- a. Fusible Switches: Quick-make, quick-break type with rejection clips for use with Class "R" fuses. Switches shall be removable from front of equipment without disturbing adjacent units or equipment bus structure.
 - b. Fuses shall be time delay current limiting types, UL Class RK-1 for motor circuits unless otherwise indicated on the drawings. Provide one spare set of fuses of each size and type in each switchboard.
 - c. Provide auxiliary contacts on switch for remote status (on-off) signaling and monitoring.

2.04 MOTOR STARTERS - 50/60Hz AC INDUCTION ELECTRIC MOTORS

A. General

1. Motor starters shall be horsepower rated for the motor connected to the starter, air insulated, with NEMA rating.
2. Motor starter coils and controls shall be designed to operate on the control voltage indicated on the control diagrams and specifications. The motor starters shall reliably pick-up and seal-in at 80% through 110% of their coil control voltage.
3. Under voltage release for motor starter coil circuit shall automatically drop motor starter off the line when the line voltage drops below normal operating voltage. Under voltage release shall be field adjustable 80% to 95% of nominal voltage with field adjustable dropout delay 0.1 to 3 seconds minimum for starters larger than NEMA size 1. The under voltage release shall reset automatically when line voltage level returns too normal. The reset time delay shall be a 0.1 to 60-second field adjustable time range for starters larger than NEMA size 1.
4. Each motor starter control circuit shall be independently fused.
5. Three phase motor starters controlling three phase motors, five (5) horsepower and larger shall provide integral motor single phasing protection. The starter shall automatically "open", turn off electrical power to the connected motor in the event of the loss of one or more circuit phases, lock out and require manual resetting of the single phase protection to restart the magnetic motor starter. Provide single-phase annunciator. Provide adjustable time delay, minimum range 0.1 to 3 seconds for initiating single phase shut down.
6. Starter units shall be equipped with individual control power transformers (grounded type) with secondary and primary control power fuses. One secondary lead shall be grounded in the unit.
 - a. The unit disconnect shall be equipped with a normally open contact to isolate the control circuit from the source when the controller disconnect is open.
 - b. The control power transformer VA load rating shall include the motor starter, additional internal and external control devices connected to the motor starter, to insure control power voltage drop does not exceed 5% of nominal rating.
7. Starter units shall be equipped with three (3) motor overload elements, one for each phase, with automatic lockout, external overload indicating flag/pilot light and manual reset external push-button. Trip rating characteristics of the overload elements shall be as recommended by motor manufacturer.
 - a. Motor overload protection relays shall be bi-metal (non-melting) "heater-element" type or solid-state type, for motor starters NEMA size 1 and smaller.
 - b. Motor overload protection relays for motor starters larger than NEMA size 1 shall be solid-state type.
8. Pilot light indicators shall be provided with "Push-to-Test" feature. Provide a capacitor in parallel with the starters stop-start control relay circuit, to permit the motor starter control circuit to "drop-out" (turn-off) and prevent "capacitive-holding" (capacitive coupling) on control circuits with "long" (excessive distance) control circuit wiring.

9. Each starter shall be equipped with a minimum of one (1) normally open and one (1) normally closed auxiliary spare contacts. Provide additional auxiliary control contacts for interlocking with system control circuits as indicated on the drawings and specifications. Auxiliary contacts shall be field convertible for normally open or normally closed operation. Contacts shall be rated not less than 10 amps at 120 volt 60Hz, AC, but in no case shall the auxiliary contacts be rated for less ampere or lower voltage than the connected control circuit.
 10. Motor starters larger than NEMA size 1, provide a running time meter 0 to 99999 hours minimum range, and an operations counter 0 to 9999 meter minimum operations start count range. Meters shall be field resettable with maintained memory during power outages of any length.
 11. Minimum starter size shall be NEMA 1, but in no case less than indicated on the drawings or specifications.
 12. Verify the exact motor connection requirements, motor locked rotor/full load current, NEMA code letter and voltage characteristics with the supplier of each motor. Motor starters shall comply with the identified requirements.
 13. Each starter shall be equipped with "Hand-off-Auto" switch or stop-start push-button as required.
 14. An auxiliary relay contact for remote alarm annunciation shall provide common trouble annunciation for any of the starter automatic protection systems. The alarm contact shall automatically reset when the starter is reset.
 15. Provide each motor starter main "start" control relay or starter coil as applicable, with a magnetic coil auxiliary control "pilot" relay. The contacts of the auxiliary control relay shall directly control the starting, running and stopping control voltage of the motor starter main control coil circuit. The coil of the auxiliary relay shall condition and match the voltage and inrush of each motor starter to the requirements of the incoming control circuit.
 16. Provide a transient surge suppressor for each motor starter coil, to limit voltage transients induced by the motor starter coil operation and to protect the motor starting circuit from voltage transients.
 17. Motor starters connected to engine generator emergency power supply source (either direct connection or connection through an automatic transfer switch) shall each be provided with a field adjustable (0.1 - 180 seconds) "start" (on delay) time delay, to provide "staggered" sequenced starting of the connected motor load.
- B. Full Voltage Non Reversing (Fvnr), Unless Noted Otherwise
1. Across the line full voltage magnetic electromechanical motor starter.
 2. Provide FVNR motor starter for motor sizes through fifty (50) horsepower (241 to 600 volt) and through thirty (30) horsepower (240 volt and under) where the motor is connected to normal power utility source, unless noted otherwise on drawings.
- C. Two Speed Motor Starters
1. The two (2) speed motor starters shall be compatible with the connected motor and shall provide automatic two (2) speed control of separate high speed and low speed motor winding or consequent pole two (2) speed motors as applicable. The starters shall be constant horsepower, constant torque or variable torque as applicable for the motor connected to the starter.
 2. Low speed compelling control shall compel the motor starter to always start the motor on low speed before switching to high speed. Compelling control shall be manual switch selectable as either "in" or "out" (bypass) of the motor control circuits.

- D. Reduced Voltage Non-Reversing (RVNR)
 - 1. General
 - a. The reduced voltage starter shall reduce both motor starting current and motor starting torque.
 - b. Reduced voltage starters shall be closed transition types.
 - c. Provide RVNR motor starters for motors larger than thirty (30) horsepower (240 volt and below) and larger than fifty (50) horsepower (over 240 volts), reduced voltage type (Where the motor starter circuit is connected to engine generator emergency power source for motors larger than five (5) horsepower, provide each respective motor with RVNR reduced voltage motor starters).
 - d. Starters shall provide field adjustable time periods for acceleration (reduced voltage) and transition (transfer to full voltage) modes, with failure to transfer lockouts and pilot light annunciators. Adjustable time range shall be 0.1 to 15 seconds.
 - e. Duty cycle - NEMA rated medium duty, starters shall provide for not less than one (1) 15-second duration starter operation in each 4-minute interval for a 1-hour period, followed by a cool down rest period of 2-hours before the duty cycle is repeated. Provide automatic temperature lockout to prevent exceeding starter duty cycle.
 - f. Reduced voltage non-reversing RVNR Motor starters shall be types described in the following paragraphs.
 - 2. Autotransformer type reduced voltage starter
 - a. Auto transformers on each phase with field adjustable transformer voltage taps for 50%, 65%, and 80% motor terminal starting voltages.
 - b. Magnetic electromechanical motor contactor type.

2.05 COMBINATION MOTOR STARTERS

- A. General
 - 1. Combination motor starters shall consist of a feeder tap device, motor starter and enclosure. Voltage and amperage rating as indicated on drawings.
 - 2. Combination motor starter shall not be less than NEMA size 1, but in no case less than indicated on the drawings.
 - 3. Unit shall be self-contained floor standing, wall mounted NEMA 1 enclosures or as indicated on the drawings. Constructed, tested and listed in accordance with NEMA, ANSI and UL standards.
 - 4. Combination motor starters as manufactured by General Electric, Westinghouse, Square D, Cutler Hammer or equal.
 - 5. Provide incoming line and outgoing load terminations, size and capacity to match connections shown.
- B. Construction
 - 1. NEMA styles metal enclosed, with full height hinged access door. 12-gauge welded frame members and 14 gauge panel members. All parts shall be removable and accessible from the front for ease of maintenance and rearrangement.
 - 2. Provide removable lifting points and permanent anchor mounting points on the enclosure.
 - 3. Hinged doors shall be mounted with removable pin hinges and secured with quarter turn indicating fasteners. A door interlock with manual defeat override shall prevent access to unit interior when the feeder tap device is in the "on" position.
 - 4. Each metal surface shall be phosphatizing prime rust inhibitor painted and baked enamel finish painted Manufacturer's standard color.
- C. Combination Motor Starter Short Circuit Coordination Protection
 - 1. The combination motor starter shall be constructed and tested to comply with the following requirements.
 - 2. Type 1 coordination:

Under short circuit conditions the contactor/motor starter shall cause no danger to persons or installation. Continued re-use shall be permitted after service, repair or replacement of parts.

3. Type 2 coordination:
 - a. Under short circuit conditions the contactor/motor starter shall cause no danger to persons or installation. Continued re-use shall be permitted without requiring any service, repair or replacement of parts.
 - b. Motor starters shall also comply with International Electromechanical Committee (IEC) Type-2 short circuit protection, as recommended by the Manufacturer's published protection tables and as certified by UL.
- D. Energy Efficient Motor Protection
 1. Where a combination motor starter is connected to a high efficiency motor, provide one (1) of the following modifications to the starters or circuit disconnects. The modification shall prevent unnecessary tripping from locked rotor high inrush motor starting current:
 - a. Circuit breaker or MCP short circuit protection - Provide circuit breaker/MCP with adjustable magnetic current trip for high inrush motor starting current, or adjustable time delay trip for high magnetic current motor inrush damping.
 - b. Switch and fuse motor short circuit protection - Provide fuses with sufficient inherent time delay to allow passage of high magnetic current inrush motor starting current.

PART 3 - EXECUTION

3.01 MOTOR CONTROL CENTER AND INDIVIDUAL COMBINATION MOTOR STARTERS

- A. Install motor control equipment in accordance with manufacturer's written instructions and applicable portions of NEMA "Standards of Installations" for switchboards and motor control centers and individual motor starters.
- B. Bolt motor control equipment to floor and wall where wall exists. Where units are free standing provide preformed steel channel or angle iron bracing to nearest wall or building structural member. Motor control equipment anchoring shall be designed for a 1.0 gravity lateral acceleration of the equipment. Submit structural calculation and details.

3.02 IDENTIFICATION

- A. Provide a red and white bakelite nameplate with ½-inch high letters fastened to face of dead-front plate, to read: "DANGER 480 (actual volts) VOLTS, KEEP OUT, AUTHORIZED PERSONNEL ONLY".
- B. Manufacturer shall stencil the panel number and name of the connected motor circuit on each device and equipment section to correspond to identification on the drawing.
- C. Identification plates and numbers shall be attached with screws or twist lock fasteners. Adhesive attachment of any kind as the only method of attachment shall not be used.

3.03 SETTINGS AND ADJUSTMENTS

- A. Program and set control function sequences, time delays, and protective device settings for correct system operation.
- B. Test all timing, control sequences and motor rotation direction for proper operation. Correct deficiencies and retest until proper operation is confirmed.

END OF SECTION
021413/212164

SECTION 26 05 48
SOUND CONTROL

PART 1 - GENERAL

1.01 SCOPE

- A. Work Included: All labor, materials, appliances, tools, equipment, facilities, transportation and services necessary for and incidental to performing all operations in connection with furnishing, delivery and installation of the work of this Section, complete as shown on the drawings and/or specified herein. Work includes, but is not necessarily limited to the following:
 - 1. Examine all other sections for work related to those other sections and required to be included as work under this section.
 - 2. General provisions and requirements for electrical work.

1.02 SUBMITTALS (ADDITIONAL REQUIREMENTS)

- A. Comply with pertinent provisions of Division 26.
- B. Submit product data sheets for vibration isolation devices.
- C. Submit detailed shop drawings including dimensioned plans, showing equipment vibration isolation anchoring.

PART 2 - PRODUCTS AND EXECUTION

2.01 QUIETNESS OF OPERATION

Before the work will be accepted as complete, quietness of operation, to a degree satisfactory to the ARCHITECT, shall be attained for apparatus, equipment, fixtures, etc., included under the electrical work. Provide isolation and vibration protection required.

2.02 VIBRATION ISOLATION FOR ELECTRICAL EQUIPMENT

- A. Objective: It is the objective of this specification to provide the necessary design for the avoidance of excessive noise or vibration in the building due to the operation of machinery or transformers, and/or due to interconnected conduit.
- B. CONTRACTOR Responsibility
 - 1. Provide a submittal to the ARCHITECT for review prior to any installation of his equipment, containing the following information:
 - a. Catalog cuts and data sheets on specific vibration isolators to be utilized showing compliance with the specification.
 - b. An itemized list showing the items of equipment to be isolated, the isolator loading and deflection and isolator placement.
 - c. Drawings showing methods for attachment of conduit to motors.
 - 2. Furnish and install the vibration isolation devices as specified herein.
 - 3. Do not install any equipment or conduit as specified in the schedule, which makes rigid contact with the "building" unless it is approved in this specification, or by the ARCHITECT. "Building" includes slabs, beams, studs, walls, lath, etc.
 - 4. Coordinate work with other trades to avoid rigid contact between equipment or conduit as specified in the schedule and the building. Inform other trades following his work, such as plastering, to avoid any contact that would reduce the vibration isolation.
 - 5. Bring to the ARCHITECT'S attention, prior to installation, any conflicts with other trades which will result in unavoidable contact to the equipment or conduit as specified in the schedule, described herein due to adequate space, etc. Corrective work necessitated by conflicts after installation shall be at the responsible CONTRACTOR'S expense.
 - 6. Bring to the ARCHITECT'S attention any discrepancies between the specifications and field conditions, changes required due to installation. Corrective work necessitated by discrepancies after installation shall be at the CONTRACTOR'S expense.
 - 7. Obtain approval from the ARCHITECT of any installation to be covered on enclosed, prior to such closure.
 - 8. Obtain written and/or oral instructions from the vibration isolation manufacturer as to the proper installation and adjustment of vibration isolation devices.
 - 9. Notify the ARCHITECT, prior to the general installation of vibration isolation devices, so that the ARCHITECT can instruct and demonstrate the technique of proper installation with the CONTRACTOR'S foreman.

10. Correct, at no additional cost, all installations, which are deemed to be defective workmanship or materials by the ARCHITECT.

2.03 VIBRATION ISOLATION TYPES

A. Isolator Description

1. Isolate all transformers with Type MN molded neoprene units equipped with leveling bolts and design status deflection under load of 0.3-inch.
2. Isolate all switchgear connected directly to transformer with Type PN isolators. Limit loading to a static deflection of 0.06 inch. Choose the area of pad to match the load with the manufacturer's recommended unit loading. An auxiliary steel plate may be required to distribute the load uniformly over the pad area.

B. Equivalent Vibration Isolators

1. Type Description	A	B	C	D	E	F	G
Neoprene Mount							
a) 0.2-inch max. deflection	N	FD	R	RV	CS	F	T-44
b) 0.4-inch max. deflection	ND	FDD	RD	RFD	FU	RD	T-44
PN Neoprene Pad	W	(1)	(2)	NR	R	(3)	100W
2. Notes	Manufacturer's Code						
(1) Elastogrip	A.	Mason Industries					
(2) Shearflex	B.	Korfund					
(3) Kinetic	C.	Vibration Mounting					
	D.	Amber/Booth					
	E.	Sausse					
	F.	Consolidated Kinetics					
	G.	Vibration Eliminator					

2.04 CONDUIT INSTALLATION

- A. Provide flexible conduit or an approved vibration isolation device between any transformer and the building structure.
- B. Secure all electrical panels connected to transformers by flexible conduit to the floor. Do not contact stud or masonry partitions. Isolated panels from the floor as specified herein.
- C. Provide flexible conduit connections to all connections to air conditioning, plumbing, etc., or any rotating or oscillating equipment requiring electrical motors. Base the length of flexible conduit required for each motor upon the requirements for a 360 degrees loop in the conduit between the electrical motor and electrical box.
- D. As an alternative to the 360 degrees loop, a Neoprene or rubber bushing between the conduit and the electric motor to break the metal-to-metal contact may be used. Provide a flexible ground strap to complete the electrical ground.

2.05 DEVICE OUTLET BOXES (INSTALLED IN COMMON PARTY SEPARATION WALLS, IN CORRIDOR WALLS AND SERVICE WALLS).

Device outlet boxes installed in walls shall be sealed on the exterior back and sides of the boxes, including wall openings around the box, with a 1/8-inch minimum thickness resilient sound absorbing, sealant. The sealant shall be free of asbestos, temperature rated from -30 F to 200 F,

self adhesive to metal and plastics, as manufactured by Lowry and Associates Inc. Sun Valley, CA. or equal.

E
N
D
O
F
S
E
C
T
I
O
N

SECTION 09 51 00

ACOUSTICAL CEILINGS

PART 1 GENERAL

1.01 SECTION INCLUDES

- A. Suspended metal grid ceiling system.
- B. Acoustical units.
- C. Supplementary acoustical insulation above ceiling.

1.02 ADMINISTRATIVE REQUIREMENTS

- A. Sequence work to ensure acoustical ceilings are not installed until building is enclosed, sufficient heat is provided, dust generating activities have terminated, and overhead work is completed, tested, and approved.
- B. Do not install acoustical units until after interior wet work is dry.

1.03 SUBMITTALS

- A. See Section 01 33 13 - Submittal Procedures.
- B. Shop Drawings: Indicate grid layout and related dimensioning.
- C. Product Data: Provide data on suspension system components.
- D. Samples: Submit two full size samples illustrating material and finish of acoustical units.
- E. Samples: Submit two samples each, 12 inches long, of suspension system main runner.
- F. Manufacturer's Installation Instructions: Indicate special procedures.
- G. Maintenance Materials: Furnish the following for Glendale Unified School District's use in maintenance of project.
 - 1. See Section 01 60 00- Product Requirements, for additional provisions.
 - 2. Extra Acoustical Units: Quantity equal to 5 percent of total installed.

1.04 QUALITY ASSURANCE

- A. Suspension System Manufacturer Qualifications: Company specializing in manufacturing the products specified in this section with minimum three years documented experience.
- B. Acoustical Unit Manufacturer Qualifications: Company specializing in manufacturing the products specified in this section with minimum three years documented experience.
- C. Comply with Specifications of the California Department of Public Health (CDPH) Standard Practice.

1.05 FIELD CONDITIONS

- A. Maintain uniform temperature of minimum 60 degrees F, and maximum humidity of 40 percent prior to, during, and after-acoustical unit installation.

PART 2 PRODUCTS

2.01 ACOUSTICAL UNITS

- A. Acoustical Units- General: ASTM E1264, Class A.

- B. Acoustical Panels Type AC-1: Painted mineral fiber, ASTM E 1264 Type III, Form 2, Pattern C E with the following characteristics:
 - 1. VOC Content: As specified in Section 01 6116.
 - 2. Size: 24 x 48 inches.
 - 3. Thickness: 3/4 inches.
 - 4. Composition: Wet felted.
 - 5. Light Reflectance: 0.90 percent, determined as specified in ASTM E 1264.
 - 6. NRC Rating: 0.70, determined as specified in ASTM E 1264.
 - 7. Ceiling Attenuation Class (CAC): 35-39, determined as specified in ASTM E 1264.
 - 8. Edge: square.
 - 9. Surface Color: White.
 - 10. Surface Pattern: medium textured.
 - 11. Product: Ultima, Item 12913HRC, by ArmstrongWorld Industries, www.armstrong.com.
 - 12. Suspension System: Exposed grid Type 1.

2.02 SUSPENSION SYSTEM(S)

- A. Manufacturers:
 - 1. Same as for acoustical units.
 - 2. Substitutions: See Section 01 60 00 - Product

Requirements. B. System Description:

- 1. Seismic Loads: Design and size components to withstand seismic loads in accordance with ASCE 7-05, Chapter 13 as specified by the International Building Code, Chapter 16. Specific seismic requirements for suspended ceiling are located in ASCE section 13.5.6
- 2. Comply with ASTM C635; die cut and interlocking components, with stabilizer bars, clips, splices, perimeter moldings, and hold down clips as required.

- C. Exposed Steel Suspension System Type 1: Formed steel, commercial quality cold rolled; heavy-duty.
 - 1. Profile: Tee; 15/16 inch wide face.
 - 2. Construction: Double web.
 - 3. Finish: White.
 - 4. Product: Prelude XL HRC by Armstrong World Industries, Inc., www.armstrong.com.

2.03 ACCESSORIES

- A. Support Channels and Hangers: Galvanized steel; size and type to suit application, seismic requirements, and ceiling system flatness requirement specified.

- B. Attachment Devices: In accordance with the ASCE 7-05, Chapter 13 as specified by the International Building Code, Chapter 16. Specific seismic requirements for suspended ceiling are located in ASCE section 13.5.6, for Category D, E, and F.
- C. Wire for Hangers and Ties: In accordance with the ASCE 7-05, Chapter 13 as specified by the International Building Code, Chapter 16. Specific seismic requirements for suspended ceiling are located in ASCE section 13.5.6.
- D. Perimeter Moldings at walls: Same material and finish as grid.
 - 1. At Exposed Grid: Nominal 15/16 inch x 15/16 inch hemmed, pre-finished angle molding (7809).
- E. Ceiling Trim at exposed edges: 150 mm high Axiom Classic Ceiling Trim by Armstrong World Industries or approved equal.
 - 1. Color: Match adjacent ceiling tile.
- F. Provide BERC2- 2 inch Beam End Retaining Clip, 0.034 inch thick, hot-dipped galvanized cold-rolled steel per ASTM A568 - used to join main beam or cross tee to wall molding.
- G. Provide SJCG- Seismic Joint Clip, 5 inches x 1-1/2 inch, hot-dipped galvanized cold-rolled steel per ASTM A568. The two piece unit is designed to accommodate a seismic separation joint. The clip is compatible with 15/16 inch and 9/16 inch grid systems including Prelude, Suprafine, and Silhouette The SJCG is not suitable for use with Vector panel installations.
- H. Provide SJMR15- Seismic Joint Clip- Main Beam, 1 inch x 4 inches, commercial quality cold rolled hot dipped galvanized steel per ASM A568, chemical cleansed.
- I. Touch-up Paint: Type and color to match acoustical and grid units.

PART 3 EXECUTION

3.01 EXAMINATION

- A. Verify existing conditions before starting work.
- B. Do not proceed with installation until all wet work such as concrete, terrazzo, plastering and painting has been completed and thoroughly dried out, unless expressly permitted by manufacturer's printed recommendations.
- C. Verify that layout of hangers will not interfere with other work.

3.02 PREPARATION

- A. Coordination: Furnish layouts for preset inserts, clips, and other ceiling anchors whose installation is specified in other sections.
 - 1. Furnish concrete inserts and similar devices to other trades for installation well in advance of time needed for coordination of other work.

3.03 INSTALLATION - SUSPENSION SYSTEM

- A. Install suspension system and panels in accordance with the ASCE 7-05, Chapter 13 as specified by the International Building Code, Chapter 16. Specific seismic requirements for suspended ceiling are located in ASCE section 13.5.6., except as noted in Section 4.4.3.1 of ESR-1308, and with the authorities having jurisdiction.
- B. ESR-1308, Section 4.4.3.1, Alternate Seismic Design Category D,E and F Installation:
 - 1. Under this installation, the runners must be rated heavy-duty and have a minimum simple span uniform load of 16.35 pounds per lineal foot (238 N/m); maximum ceiling weight permitted is 4.0 pounds per square foot (19.5 kg/m²).
 - 2. The BERC-2 clip is used to secure the main runners and cross runners on two adjacent

walls to the structure and the two opposite walls to the perimeter trim, as detailed below. A nominal 7/8-inch (22 mm) wall molding is used in lieu of the 2-inch (51 mm) perimeter supporting closure angle required by Section 9.6.2.6.2.2 (b) of ASCE-7 for Seismic Design Categories D, E and F. Except for the use of the BERC-2 clip and the 7/8-inch (22 mm) wall molding and elimination of spreader bars, installation of the ceiling system must be as prescribed by the applicable code.

3. The BERC-2 clip is attached to the wall molding by sliding the locking lances over the hem of the vertical leg of the wall molding. Clips installed on the walls where the runners are fixed are attached to the runner by a sheet metal screw through the horizontal slot in the clip into the web of the runner.
 - a. Alternate #2: If acceptable to architect, fixed attachment may be accomplished by pop-riveting the runner to the wall molding.
4. Clips installed on the walls where the runners are not fixed to the runner allow the terminal runner end to move 3/4 inch (19.1 mm) in both directions. BERC-2 clips installed in this manner are an acceptable means of preventing runners from spreading in lieu of spacer bars required in CISCA 3-4, which is referenced in ASCE 7, Section 9.6.2.6.2.2, which is referenced in ASCE 7-05, Chapter 13 as specified by the International Building Code; Chapter 16. Specific seismic requirements for suspended ceiling are located in ASCE section 13.5.6.

- C. The SJCG Seismic Separation Joint Clip is to be installed per the manufacturer's instructions, CS-3815.
- D. The SJMR15 Seismic Joint Clip Main Beam is to be installed per the manufacturer's instructions, CS-3955.
- E. Install after major above-ceiling work is complete. Coordinate the location of hangers with other work.
- F. Hang suspension system independent of walls, columns, ducts, pipes and conduit. Where carrying members are spliced, avoid visible displacement of face plane of adjacent members.
- G. Where ducts or other equipment prevent the regular spacing of hangers, reinforce the nearest affected hangers and related carrying channels to span the extra distance.
- H. Do not support components on main runners or cross runners if weight causes total dead load to exceed deflection capability.
- I. Support fixture loads using supplementary hangers located within 6 inches of each corner, or support components independently.
- J. Do not eccentrically load system or induce rotation of runners.

3.04 INSTALLATION- ACOUSTICAL UNITS

- A. Install acoustical units in accordance with manufacturer's instructions.
- B. Fit acoustical units in place, free from damaged edges or other defects detrimental to appearance and function.
- C. Fit border trim neatly against abutting surfaces.
- D. Install units after above-ceiling work is complete.
- E. Install acoustical units level, in uniform plane, and free from twist, warp, and dents.
- F. Cutting Acoustical Units:

1. Cut to fit irregular grid and perimeter edge trim.
2. Make field cut edges of same profile as factory edges.
3. Double cut and field paint exposed reveal edges.

G. Where round obstructions occur, provide preformed closures to match perimeter molding.

3.05 TOLERANCES

- A. Maximum Variation from Flat and Level Surface: 1/8 inch in 10 feet.
- B. Maximum Variation from Plumb of Grid Members Caused by Eccentric Loads: 2 degrees.

3.06 ADJUSTING AND CLEANING

- A. Replace damaged and broken panels.
- B. Clean exposed surfaces of acoustical ceilings, including trim, edge moldings, and suspension members. Comply with manufacturer's instructions for cleaning and touch up of minor finish damage. Remove and replace work that cannot be successfully cleaned and repaired to permanently eliminate evidence of damage.

END OF SECTION

EXECUTION

4.01

USE OF PREMISES

- A. CONTRACTOR shall coordinate Work of all trades, Subcontractors, utility service providers, with OWNER and/or Separate Work Contract. CONTRACTOR shall sequence, coordinate, and perform the Work to impose minimum hardship on the operation and use of the existing facilities and/or Project site. CONTRACTOR shall install all necessary protection for existing improvements, Project site, property, and new Work against dust, dirt, weather, damage, vandalism, and maintain and relocate all protection to accommodate progression of the Work.
- B. CONTRACTOR shall confine entrance and exiting to the Project site and/or facilities to routes designated by the DISTRICT
- C. Within existing facilities, OWNER will remove portable equipment, furniture, and supplies from Work areas prior to the start of Work. CONTRACTOR shall cover and protect remaining items in areas of the Work
- D. CONTRACTOR is advised school may be in session during performance of the Work. CONTRACTOR shall utilize all available means to prevent generation of unnecessary noise and maintain noise levels to a minimum. When required by the DISTRICT, CONTRACTOR shall immediately discontinue noise-generating activities and/or provide alternative methods to minimize noise generation. CONTRACTOR shall install and maintain air compressors, tractors, cranes, hoists, vehicles, and other internal combustion engine equipment with mufflers, including unloading cycle of compressors. CONTRACTOR shall discontinue operation of equipment producing objectionable noise as required by the DISTRICT.
- E. CONTRACTOR shall furnish, install, and maintain adequate supports, shoring, and bracing to preserve structural integrity and prevent collapse of existing improvements and/or Work modified and/or altered as part of the Work.
- F. CONTRACTOR shall secure building entrances, exits, and Work areas with locking devices as required by the DISTRICT.
- G. CONTRACTOR assumes custody and control of OWNER property, both fixed and portable, remaining in existing facilities vacated during the Work.
- H. CONTRACTOR shall cover and protect surfaces of rooms and spaces in existing facilities turned over for the Work, including OWNER property remaining within as required to prevent soiling or damage from dust, dirt, water, and/or fumes. CONTRACTOR shall protect areas adjacent to the Work in a similar manner. Prior to OWNER occupancy, CONTRACTOR shall clean all surfaces including OWNER property.
- I. CONTRACTOR shall not use or allow anyone other than OWNER employees to use facility telephones and/or other equipment, except in an emergency. CONTRACTOR shall reimburse OWNER for telephone toll charges originating from the facility except those arising from emergencies or use by OWNER employees.
- J. CONTRACTOR shall protect all surfaces, coverings, materials, and finished Work from damage. Mobile equipment shall be provided with pneumatic tires.
- K. CONTRACTOR is advised OWNER will award Separate Work Contracts at this Project site.
- L. CONTRACTOR shall not permit the use of portable and/or fixed radio's or other types of sound producing devices including walk mans and similar devices.

4.02 PROPERTY INVENTORY

- A. Property, OWNER intends to remove; will be removed by OWNER before a room or space is vacated for the Work. Before performing Work in each room or space, DISTRICT and CONTRACTOR shall prepare a detailed initial written inventory of OWNER property remaining within, including equipment and telephone instruments and the condition thereof. DISTRICT and CONTRACTOR shall retain a signed copy of the inventory dated and signed by both parties. Prior to subsequent OWNER occupancy of each such room or space, DISTRICT and CONTRACTOR shall perform a final inventory of OWNER property and all discrepancies between the initial inventory and final inventory shall be the responsibility of CONTRACTOR.

4.03 FURNITURE, FIXTURES AND EQUIPMENT (MATERIALS) OWNER FURNISHED CONTRACTOR INSTALLED (OFCI)

- A. Certain materials identified in the Contract Documents as OWNER Furnished CONTRACTOR Installed, OFCI, will be delivered to the Project site by the OWNER.
- B. If designated in the Contract Documents to be OWNER furnished CONTRACTOR installed, (OFCI), and **CONTRACTOR** shall unload, store, uncrate, assemble, install, and connect OWNER supplied materials.
- C. Forty Eight (48) hours before the date the CONTRACTOR needs to have the OFCI materials on site, CONTRACTOR shall notify OWNER of the scheduled date for needed OFCI materials. Upon delivery to Project site, CONTRACTOR shall store OFCI materials inside rooms and/or protected spaces and will be responsible for security of OFCI materials until Substantial Completion. DISTRICT will sign receipt or bill of lading as applicable.
- D. CONTRACTOR shall, within one (1) day after delivery, uncrate and/or unpack OFCI materials in presence of OWNER who shall inspect delivered items. OWNER shall prepare an inspection report listing damaged or missing parts and accessories. OWNER shall transmit one (1) copy of the report to CONTRACTOR. OWNER will procure and/or replace missing and or damaged OFCI materials, as indicated in inspection report.
- E. CONTRACTOR shall install OFCI materials in the locations and orientation as indicated in the Contract Documents. CONTRACTOR shall verify exact locations with DISTRICT before final installation of OFCI materials.
- F. If required, DISTRICT will furnish setting and or placement drawings for OFCI materials.
- G. CONTRACTOR shall install OFCI materials by proper means and methods to ensure an installation as recommended by the manufacturer. CONTRACTOR shall furnish and install all necessary fasteners and required blocking to properly install OFCI materials.
- H. CONTRACTOR shall install OFCI materials with manufacturer recommended fasteners for the type of construction to which the OFCI materials are being fastened and/or anchored.
- I. CONTRACTOR shall provide final connections of any electrical, signal, gas, water, waste, venting and/or similar items to OFCI materials. CONTRACTOR shall, prior to final connection, verify the operating characteristics of OFCI materials are consistent with the designated supply.
- J. . General: All such work indicated in Contract Documents and/or specified herein.
- k. Coordination:
 - 1. Contractor shall schedule and coordinate Owner work with his work; give 5 days min. advance notice of all dates; verify that Owner work has been accomplished prior to beginning his work
- L. Owner Furnished Items or Products (IF ANY):
 - 1. Owner Responsibilities:
 - a. Delivery of items or products to site.

- b. Schedule delivery date with supplier in accord with Contractor's schedule.
- c. Obtain installation drawings and instructions.
- d. Submit claims for transportation damages.
- e. Arrange guarantees, warranties.

2. Contractor's Responsibilities:

- a. Schedule required delivery date for each product, and inform Owner.
- b. Promptly inspect delivered products, report damaged or defective items.
- c. Unload; handle at site, including uncrating and storage.
- d. Protect from exposure to elements, from damage.
- e. Repair or replace items damaged as result of Contractor's operations.
- f. Install, connect, finish products.

- B. The Contractor shall provide adequate storage within his fenced staging area, to store the equipment. The Contractor is solely responsible for the storage of this equipment within his staging area and all subsequent movement of this equipment. The Contractor shall be solely responsible for the maintenance and protection of all material.
- C. Bidders submitting under this Contract shall include the price for all necessary coordination with the District and the equipment manufacturer, as required for proper and complete coordination between all trades and all Contractors, within their bid.

4.04 WORK BY OTHERS

- A. The District reserves the right to do other work in connection with the project or adjacent thereto by contract or otherwise, and Contractor shall at all times conduct the work so as to impose no hardship on District or others engaged in District's work nor to cause any unreasonably delay or hindrance thereto.
- B. Where two or more Contractors are employed on related or adjacent work, each shall conduct their operation in such a manner as not to cause delay or additional expense to the other.
- C. Contractor shall be responsible to others engaged in the related or adjacent work for all damage to work, to persons, or for loss by failure to finish the work within the specified time for completion. Contractor shall coordinate his work with the work of others so that no discrepancies shall result in the project.

PART 9 – GENERAL NOTES

5.01 GENERAL NOTES

- A. Work areas and detailed scope of work are shown under PART 2.01.
- B. It is the responsibility of the contractor to examine the site of the work and after investigation to decide for himself the character of materials, equipment and utilities to be encountered and all other conditions affecting the work. It is also his responsibility to provide sufficient costs to cover the provisions of all items of work under the existing conditions referred to herein.
- C. CONTRACTOR is responsible to review the AHERA – Inspection reports for any presence of asbestos containing materials (ACM). CONTRACTOR shall immediately notify OWNER of the presence or suspected presence of any ACM found during the course of the work, prior to the disturbance of the subject materials. At the sole direction of the OWNER, contractor may be required to stop all work on all or any portion of the project until ACM materials are properly abated by OWNER.
- C. All work areas have available access. The Contractor will be issued keys for the sites through the District Facilities and Support Operations Department to allow access at the sites. Contractor will ensure they secure all areas that are accessed by their personnel to ensure the security of the site.
- D. Contractor shall provide trash bins and storage facilities for use at the site. The contractor shall not use school facilities for these purposes. It will be the contractor's responsibility to maintain and keep those facilities neat and clean at all times.
- E. There may be other contractors or District workers working at the job site. Contractor will be responsible to coordinate his work with their schedules.
- F. The Representative will have the right to stop the work immediately in case he sees a discrepancy or work not following the specifications. The contractor will not be let to continue to work until corrections are made and approval and permission given by the District Representative.

5.02 RESTRICTIONS

- A. Use of the Site: Limit use of the premises to work in areas indicated. Confine operations to areas within contract limits indicated. Do not disturb portions of the site beyond the work areas in which the work is indicated. Allow for Owner occupancy and use by the public.
- B. Use of the Existing Buildings: Repair damages caused by construction operations. Take all precautions necessary to protect the existing buildings and their occupants during the construction period.
- C. Driveways and Entrances: Keep driveways and entrances serving the premises clear and available to the Owner, the Owner's employees, other contractors working, and emergency vehicles at all times.
- D. Full Owner Occupancy: The Owner may occupy the site and existing buildings during the entire construction period. Cooperate with the owner during construction operations to minimize conflicts and facilitate owner usage. Perform the work so as not to interfere with the Owner's operations.

5.03 PERMISSIBLE WORKING DAYS AND HOURS

- A. Work may be conducted as follows:

- B. This school is on a traditional school year calendar, August through June. During the period of this contract, school events and educational requirements will limit or prevent access, and will affect Contractor work hours for a portion or all of the school building (s) pertinent to the contract. Contractor shall maintain schedule with full knowledge of these times and dates to be determined. A site-specific calendar will include currently known dates of limited access, or times of the school day that noise will have to be limited, or ceased. These shall include during the time of the project, but not be limited to:
1. **No work after 6:00 p.m. on six (6) weekday evenings** for back-to-school, open house, and other events per school year at each school site.
 2. **No work between 8:00 a.m. and 10:00 a.m. on five (5) student attendance weekdays** for assembly events per school year.
 3. **NO NOISE/WORK will be allowed on an Elementary school site between 8:00 a.m. and 12:30 p.m. on twelve (12) student attendance weekdays for testing (four (4) consecutive weekdays, three times) per school year.** Second shift work may be accommodated with the request pre-approved by the District Project Manager.
 4. **NO NOISE/WORK will be allowed on a Middle School or High School site between 8:00 a.m. and 1:30 p.m. on twenty (20) student attendance weekdays for testing (four (4) consecutive weekdays during the first semester; sixteen (16) consecutive weekdays during the second semester) per school year.** Second shift work may be accommodated with the request pre-approved by the District Project Manager.
- C. It shall be noted that there are students in the Early and Extended Education Learning Program in attendance on the Elementary school sites from 6:00 a.m. through 6:00 p.m. on a daily basis throughout the school year, and on each day that Classified Staff are assigned working hours (see specific EEELP calendar for each site, per each school year).
- D. Work hours for the Project shall be from 7:00 a.m. until 10:00 p.m. Monday through Saturday, unless advance permission to deviate from these hours is obtained from the City of Glendale per Glendale Municipal Code, Title 8, Chapter 36, and this request is also approved in writing five working days beforehand by the District Project Manager.
- E. Subject to local ordinances, CONTRACTOR may work any hours on Saturdays, Sundays, and any non-school session days, when written notification to the District has been submitted and the anticipated schedule of work has been approved.

SECTION 01 74 10

CLEANING

PART 10 - GENERAL

10.01 SECTION INCLUDES:

- A. Maintain premises and adjacent public and private properties free from accumulations of waste, debris, and rubbish, caused by operations during the project.
- B. At completion of Work, remove waste materials rubbish, tools, equipment, machinery and surplus materials, and clean all exposed surfaces; leave project clean and ready for occupancy.

PART 10.2 - PRODUCTS

10.2.01 MATERIALS:

- A. Use only cleaning materials recommended by the manufacturer of surface to be cleaned.
- B. Use cleaning materials only on proper surfaces recommended by the manufacturer.

PART 10.3 - EXECUTION

10.3.01 DURING CONSTRUCTION:

- A. Execute daily cleaning plans from each trade to ensure that buildings, grounds, and public and private properties are maintained free from accumulations of waste materials, rubbish and trash on a daily basis.
 - B. Wet down dry materials and rubbish to prevent blowing dust and debris on and from the construction work.
 - C. Daily, during progress of work, clean construction site and utilized public properties, and dispose of waste materials, debris and rubbish.
 - D. Provide on-site steel dump containers and appropriately sized trash containers for collection of waste materials, debris and rubbish. DO NOT USE SITE CONTAINERS.
 - E. Remove waste materials, debris and rubbish from site and legally dispose of at public or private dumping areas off the District's property.
 - F. Vacuum clean and wet wipe interior building walls, floors, doors, windows, and hardware in preparation for and when ready to receive finish preparation and painting. Continue vacuum cleaning on an as-needed basis until building is ready final inspection by the Architect, Inspector, and Project Manager and determined to be ready for substantial completion and occupancy.
 - G. Handle materials in a controlled manner to minimize any unnecessary waste or debris emanating from the construction areas. Do not drop or throw materials from heights: rather, a closed chute shall be used, to minimize unnecessary dust, waste or debris from the construction area.
- A. Schedule cleaning operations so that dust and other contaminants resulting from cleaning process will not migrate into new equipment or furniture, or onto wet, newly painted, or finished surfaces.

10.3.02 FINAL CLEANING:

- A. Employ experienced workmen, or professional cleaners, for final cleaning.
- B. Exterior: Clean surfaces of the construction and site including, but not limited to, fixtures, walls, soffits, floors, hardware, roofs, window and opening ledges and sills, horizontal projections, steps and platforms, walkways, rails and all like surfaces, and adjoining private and public property to the extent soiled by the Contractor's operations.
- C. Interior: Leave all horizontal and vertical surfaces in vacuum cleaned, wet-wiped condition with all dust, dirt, stains, hand marks, paint spots, droppings, and other blemishes and defects completely removed, and conform to the following requirements:
 - 1. Hard Floors: Freshly administer specified product sealants, and Wet mop/wash and dry, concrete, Portland cement flooring, tile, elastomeric, epoxy, refinished and colored concrete, and similar hard floor surfaces free of dust, streaks or stains.
 - 2. Resilient Flooring: Freshly wax and buff as specified in Section 09 65 00.
 - 3. Wood Flooring: Remove defects and blemishes by sanding surface and painting according to Section 09 90 00.
 - 4. Resilient Bases: Clean off adhesive smears and wipe clean with wet-wipe methods.
 - 5. Unpainted and Painted Surfaces: Clean of dust, lint, streaks or stains, utilizing wet-wipe methods as necessary.
 - 6. Tile Walls: Clean and polish per manufacturer's specifications.
 - 7. Hardware and Metal Surfaces: Clean and polish all exposed surfaces using non-corrosive and nonabrasive materials.
 - 8. Glass: Wash and polish both sides, and leave free of dirt, spots, streaks, and labels. Clean and polish mirrors.
 - 9. Ceilings: Clean and free of stains, hand marks, and defacing.
 - 10. Replace air conditioning filters as specified in Mechanical Specifications.
 - 11. Clean ducts, blowers and coils, if air conditioning units are found to have been operated without filters during construction, and after final inspection.
 - 12. Lighting fixtures: Replace lamps and clean fixtures and lenses if fixtures or lamps are dirty or have smudges or dust.
 - 13. Fixtures and Equipment: Clean and polish mechanical and electrical fixtures and like items. Leave lighting fixtures free of dust, dirt, stains or waste material. Clean and service equipment and machinery, leaving ready for use.
 - 14. Surfaces Not Mentioned: Clean according to the intent of this Section and as required for Architect's approval.

- E. Contaminated Earth: Final clean-up operation includes the removal and disposal of earth that is contaminated or unsuitable for support of plant life in planting areas, and filling the resulting excavations with suitable soil as directed and approved by the Architect, Inspector, and/or Project Manager.

Contaminated areas include those used for disposal of waste concrete, mortar, plaster, masonry, paints, and similar materials, and areas in which washing out of concrete and plaster mixers or washing of tools and like cleaning operations have been performed, and all areas and adjacent areas that have been oiled, paved, or chemically treated.

Do not dispose of waste, oil, solvents, paints, solutions, or like penetrating material by depositing or burying on School property; dispose of such material in a lawful manner.

END OF SECTION