

Interim Housing Monte Vista Elementary School

tBP Project No. 21056.00

DSA #03 - 121306

File # 19-41

Bid No:

Glendale Unified School District
Glendale, California

PROJECT MANUAL

Volume 1 of 1
Divisions 00 - 33
March 2021

Architect:

tBP/Architecture

4611 Teller Ave. Newport Beach, CA 92660-2104

949. 673. 0300

tBP

Architecture
Planning
Interiors
Management

**SECTION 00 01 01
PROJECT TITLE PAGE**

FOR

INTERIM HOUSING

PROJECT NUMBER: 21056.00

DISTRICT

**GLENDALE UNIFIED SCHOOL DISTRICT
349 WEST MAGNOLIA, GLENDALE, CA 91204
818.507.0201
WWW.GUSD.NET**

PROJECT LOCATION

**MONTE VISTA ELEMENTARY SCHOOL
2620 ORANGE AVENUE
LA CRESCENTA-MONTROSE , CALIFORNIA 91214**

PREPARED BY:

ARCHITECT

TBP/ARCHITECTURE

4611 Teller Avenue, Newport Beach, CA 92660
949.673.0300
www.tbparchitecture.com

NOTICE: This Project Manual, is an unpublished instrument of service of the authors. It is prepared for use only on this Project and in conjunction with the authors' interpretations, observations, decisions and administration, as described in the Conditions of the Contract. Desired results without these services cannot be assured. Use in whole or in part, without the authors' services and expressed written consent may violate Act 17 U.S.C. par. 301 (1991).

END OF PROJECT TITLE PAGE

SECTION 00 01 02
PROJECT INFORMATION

PART 1 GENERAL

1.01 PROJECT IDENTIFICATION

- A. Project Name: Interim Housing, located at:
 - Project Number: 21056.00.
 - Monte Vista Elementary School.
 - 2620 Orange Avenue.
 - La Crescenta-Montrose, California 91214.
- B. The Owner, hereinafter referred to as District: Glendale Unified School District
Glendale Unified School District
 - 349 West Magnolia, Glendale, CA 91204
 - www.gusd.net
 - 818.507.0201

1.02 NOTICE TO PROSPECTIVE BIDDERS

- A. These documents constitute an Invitation to Bid to and request for qualifications from General Contractors for the construction of the project described below.

1.03 PROJECT DESCRIPTION

- A. Summary Project Description: Project Description.
- B. Contract Scope: Grading and underground utilities, Construction, and demolition.
- C. Contract Terms: Lump sum (fixed price, stipulated sum).

1.04 PROJECT CONSULTANTS

- A. The Architect, hereinafter referred to as Architect: **tBP/Architecture**
 - 4611 Teller Avenue, Newport Beach, CA 92660
 - www.tbparhitecture.com
 - 949.673.0300

1.05 PROCUREMENT TIMETABLE

- A. Bids May Not Be Withdrawn Until: 30 days after due date.
- B. Contract Time: To be stated in bid documents.
- C. The District reserves the right to change the schedule or terminate the entire procurement process at any time.

1.06 PROCUREMENT DOCUMENTS

- A. Availability of Documents: Complete sets of procurement documents may be obtained:
 - 1. From District at the Project Manager's address listed above.

PART 2 PRODUCTS (NOT USED)

PART 3 EXECUTION (NOT USED)

END OF SECTION

SECTION 00 01 07
SEALS PAGE

ARCHITECT OF RECORD (AOR)

TBP/ARCHITECTURE

4611 Teller Avenue, Newport Beach, CA 92660

Hung L. Cheng C-34187



STRUCTURAL ENGINEER OF RECORD (SEOR)

VCA ENGINEERS, INC.

2151 Michelson Drive, Suite 240, Irvine, California 92612

Young-Keun Nam S-4029



ELECTRICAL ENGINEER OF RECORD (EEOR)

FBA ENGINEERING

150 Paularino Avenue, Suite A120, Costa Mesa CA 92626

Stephen R. Zajicek E-10372



CIVIL ENGINEER OF RECORD (CEOR)

FPL & ASSOCIATES

30 Corporate Park, Suite 401, Irvine, California 92606

Alan Wing-Chi Lee, CE C-34971



END OF SECTION

SECTION 00 01 10
TABLE OF CONTENTS

PROCUREMENT AND CONTRACTING REQUIREMENTS

DIVISION 00 -- PROCUREMENT AND CONTRACTING REQUIREMENTS

- 00 01 01 - Project Title Page
- 00 01 02 - Project Information
- 00 01 07 - Seals Page
- 00 01 10 - Table of Contents
- 00 40 25 - Request for Information
- 00 43 25 - Substitution Request Form - During Procurement
- 00 63 25 - Substitution Request Form - During Construction

SPECIFICATIONS

DIVISION 01 -- GENERAL REQUIREMENTS

- 01 10 00 - Summary
- 01 20 00 - Price and Payment Procedures
- 01 25 00 - Substitution Procedures
- 01 30 00 - Administrative Requirements
 - 01 30 00.01 - Request for Interpretation
- 01 35 50 - Requests for Electronic Files
- 01 35 53 - Security Procedures
- 01 40 00 - Quality Requirements
- 01 41 00 - Regulatory Requirements
- 01 42 19 - Reference Standards
- 01 45 33 - Code-Required Special Inspections
- 01 50 00 - Temporary Facilities and Controls
- 01 57 23 - Temporary Storm Water Pollution Control
- 01 58 13 - Temporary Project Signage
- 01 60 00 - Product Requirements
- 01 61 16 - Volatile Organic Compound (VOC) Content Restrictions
 - 01 61 16.01 - Accessory Material VOC Content Certification Form
- 01 70 00 - Execution and Closeout Requirements
- 01 71 23 - Field Engineering
- 01 74 19 - Construction Waste Management and Disposal
- 01 78 00 - Closeout Submittals

01 78 00.01 - Warranty Form Letter

01 79 00 - Demonstration and Training

DIVISION 02 -- EXISTING CONDITIONS

02 41 00 - Demolition

02 43 00 - Structure Moving

DIVISION 03 -- CONCRETE

03 10 00 - Concrete Forming and Accessories

03 20 00 - Concrete Reinforcing

03 30 00 - Cast-in-Place Concrete

DIVISION 04 -- MASONRY

04 05 11 - Masonry Mortaring and Grouting

04 20 00 - Unit Masonry

DIVISION 05 -- METALS

05 50 00 - Metal Fabrications

05 52 13 - Pipe and Tube Railings

DIVISION 06 -- WOOD, PLASTICS, AND COMPOSITES

06 10 00 - Rough Carpentry

DIVISION 07 -- THERMAL AND MOISTURE PROTECTION

07 13 00 - Sheet Waterproofing

07 92 00 - Joint Sealants

DIVISION 10 -- SPECIALTIES

10 14 00 - Signage

10 28 00 - Toilet Accessories

DIVISION 26 -- ELECTRICAL

26 05 00 - Common Work Results for Electrical

26 05 01 - Basic Electrical Materials and Methods

26 05 30 - Conduit and Wire

26 24 13 - Switchboards

26 50 00 - Lighting Fixtures

DIVISION 27 -- COMMUNICATIONS

27 21 00 - Electronic Network Systems Infrastructure

27 51 13 - Integrated Communications System

27 51 26 - Portable Assistive Listening System

DIVISION 28 -- ELECTRONIC SAFETY AND SECURITY

28 31 00 - Intrusion Detection System

28 46 20 - Fire Detection and Alarm

DIVISION 31 -- EARTHWORK

31 10 00 - Site Clearing

31 22 00 - Grading

DIVISION 32 -- EXTERIOR IMPROVEMENTS

32 12 16 - Asphalt Paving

32 12 36 - Seal Coats

32 13 13 - Concrete Paving

32 17 23.13 - Painted Pavement Markings

DIVISION 33 -- UTILITIES

33 14 16 - Site Water Distribution Piping

33 30 00 - Sanitary Utilities

END OF SECTION

**SECTION 00 40 25
REQUEST FOR INFORMATION**

RFI NUMBER: _____ **DATE:** _____

PROJECT NAME: INTERIM HOUSING PROJECT NO.: 21056.00

TO: TBP/ARCHITECTURE

4611 Teller Avenue, Newport Beach, CA 92660

Attention: _____

Contractor: _____

Address: _____

Request By: _____ Date: _____

BRIEF SUMMARY OF RFI: _____

Drawing No. _____ Detail No. _____

Specification Section _____ Title _____

Page _____ Paragraph _____

DETAILS OF THIS RFI: _____

Attachments: _____

RESPONSE WILL BE INCLUDED IN AN ADDENDUM

END OF RFI

SECTION 00 43 25
SUBSTITUTION REQUEST FORM - DURING PROCUREMENT

SUBSTITUTION REQUEST NO. _____

DATE: _____

PROJECT NAME: **INTERIM HOUSING**

PROJECT NUMBER: **21056.00**

TO: **TBP/ARCHITECTURE**

 4611 Teller Avenue, Newport Beach, CA 92660

From: _____

We hereby submit for your consideration the following product comparisons of the specified product and the proposed substitution. The undersigned fully understands that failure to answer any item below may be cause for rejection of request for substitution.

Request for substitution shall only be made during bidding (not later than 7 days prior to bid opening for inclusion by Addendum) except under conditions beyond control of Contractor.

SPECIFIED PRODUCT: _____

Project Manual Section Title _____ Number ___ Page ____ Paragraph ____.

Drawing No. _____ Detail No. _____

Proposed Substitution: _____

Manufacturer: _____ Tel: _____

A. Is the point-by-point comparative data attached? — REQUIRED BY A/E

B. Reason request for substitution is being submitted: _____

DIFFERENCES BETWEEN PROPOSED SUBSTITUTION AND SPECIFIED PRODUCT

A. Does proposed substitution affect in any way the Structural Safety, Access Compliance, or Fire & Life Safety portions of the project? No__ Yes__

Explain _____

B. Does proposed substitution affect dimensions, gages, weights, etc. on Drawing? No__ Yes__

Explain _____

- C. Does proposed substitution require changes in Drawings or design and installation changes?
No__ Yes__ _____
(If yes, cost of these changes is the responsibility of the Contractor.)
- D. Does proposed substitution affect product cost, delivery time, or construction schedule?
No__ Yes__ Explain _____
- E. Does proposed substitution comply with specified ICC Number, UL Rating, ASTM Numbers?
No__ Yes__ Explain _____
- F. Does proposed substitution affect other trades and systems such as wiring, piping, ductwork, structure, etc.? No ___ Yes ____ (Explain which and how) _____

- G. Does proposed substitution product guarantee differ from that of the specified product?
No__ Yes__ Explain _____

Attach a listing of 3 similar projects (one in service for at least 3 years) using the proposed substitution.

Substantiating Data: Attach product data/brochures and Vendor qualifications for both specified and substitute product. Provide samples for both specified and substitute products, if applicable.

Certification: Undersigned has examined Construction Documents, is familiar with specified product, understands indicated application of product, and understands design intent of the Architect caused by the requested substitution.

Submitted by: _____
 (Type Name) Signature Date

Signature must be made by person having legal authority to bind his firm to the above terms.

END OF SECTION

SECTION 00 63 25
SUBSTITUTION REQUEST FORM - DURING CONSTRUCTION

SUBSTITUTION REQUEST NO. _____

DATE: _____

PROJECT NAME: INTERIM HOUSING

PROJECT NUMBER: 21056.00

TO: TBP/ARCHITECTURE

4611 Teller Avenue, Newport Beach, CA 92660

From: _____

We hereby submit for your consideration the following product comparisons of the specified product and the proposed substitution. The undersigned fully understands that failure to answer any item below may be cause for rejection of request for substitution.

This request for substitution form shall only be used after the end of the bidding period except under conditions beyond control of Contractor.

Specified Product: _____

Project Manual Section Title _____ Number ___ Page ___ Paragraph ___.

Drawing No. _____ Detail No. _____

Proposed Substitution: _____

Manufacturer: _____ Tel: _____

A. Reason request for substitution is being submitted: _____

B. Does proposed substitution affect in any way the Structural Safety, Access Compliance, or Fire & Life Safety portions of the project? No__ Yes__

Explain _____

C. Does proposed substitution affect dimensions, gages, weights, etc. on Drawing? No__ Yes__

Explain _____

D. Does proposed substitution require changes in Drawings or design and installation changes? No__ Yes__

(If yes, cost of Architect and Engineer document changes are the responsibility of the Contractor.)

- E. Does proposed substitution affect product cost, delivery time, or construction schedule?
 No ___ Yes ___ Explain _____
- F. Does proposed substitution comply with specified ICC Number, UL Rating, ASTM Numbers?
 No ___ Yes ___ Explain _____
- G. Does proposed substitution affect other trades and systems such as wiring, piping, ductwork, structure, etc.? No ___ Yes ___ (Explain which and how) _____

If yes, has impact on their work been included in price of proposed substitution? No ___ Yes ___.

- H. Does proposed substitution product guarantee differ from that of the specified product?
 No ___ Yes ___ Explain _____

If the substitution request is accepted, it will result in:

No cost impact ___ Improve Schedule ___ Credit of \$ _____

Attach a listing of 3 projects (one in service for at least 3 years) using the proposed substitution.

Substantiating Data: Attach product data/brochures and Vendor qualifications for both specified and substitute product. Provide samples for both specified and substitute products, if applicable.

Certification: Undersigned has examined Construction Documents, is familiar with specified product, understands indicated application of product, and understands design intent of the Architect caused by the requested substitution.

Submitted by: _____
 (Type Name) Signature Date

Signature must be made by person having legal authority to bind his firm to the above terms.

Architect's Comments:

___ Accepted, ___ accepted as noted, ___ not accepted, ___ received too late.

Reviewed by:

 Architect Date

 Construction Manager Date

 District Date

END OF SECTION

SECTION 01 10 00
SUMMARY

PART 1 GENERAL

1.01 PROJECT

- A. Project Name: Interim Housing
- B. District's Name: Glendale Unified School District.
- C. Architect's Name: tBP/Architecture.
- D. The Project consists of the alteration of existing relocatable buildings and related sitework located at Monte Vista Elementary School.

1.02 CONTRACT DESCRIPTION

- A. Contract Type: A single prime contract based on a Stipulated Price as described in Owner-Contractor Agreement.
- B. The Work: The Work is construction and related services for a , CBC, Occupancy Type Educational Group E, Construction Type V-B, , totaling approximately 6720 square feet.

1.03 CONTRACT DOCUMENTS

- A. Contract Requirements:
 - 1. Conditions of the Contract and other Contract documents have been included in the Project Manual, as indicated in the Table of Contents.
 - a. Such documents are not Specifications.
 - 2. Specifications are found in Divisions 01 through 33 of the Project Manual.
- B. Contract Drawings: The Drawings provided with and identified in the Project Manual are the Drawings referenced in the Agreement.
 - 1. The location, extent and configuration of the required construction and improvements are shown and noted on Drawings.
 - a. The Drawings are referenced in the Agreement.
 - b. An index of Drawings is included in the set of Drawings.
 - 2. Drawings are arranged into series according to design discipline. Such organization and all references to trades, subcontractor, specialty contractor or supplier shall not control the Contractor in dividing the Work among subcontractors or in establishing the extent of the Work to be performed by any trade.
 - 3. Where the terms "as shown", "as indicated", "as noted", "as detailed", "as scheduled", or terms of like meaning, are used in the Drawings or Specifications, it shall be understood that reference is being made to the Drawings referenced in the Agreement.
 - 4. Where reference to the word "plans" is made anywhere in Drawings, Specifications and related Contract Documents, it shall be understood to mean the Drawings referenced in the Agreement.
- C. Contract Specifications: The Specifications provided in the Project Manual are the Specifications referenced in the Agreement.

1. Specifications are organized by Divisions and Sections in accordance with the recommended practices of the Construction Specifications Institute.
 - a. Such organization shall not control the Contractor in dividing the Work among subcontractors or in establishing the extent of Work to be performed by any trade.
2. Specifications are included in the Project Manual, which may also include other Bidding and Contract Documents.
 - a. Contents of the Project Manual are listed in Document 00 01 10 - Table of Contents, in the Project Manual.

1.04 DESCRIPTION OF ALTERATIONS WORK

- A. Scope of demolition and removal work is indicated on drawings and specified in Section 02 41 00.
 1. The intent of these drawings and specifications are the work of the alteration, rehabilitation, or reconstruction of this facility shall be submitted and approved by DSA before proceeding with the repair work. CAC Section 4-317.
- B. Scope of alterations work is indicated on drawings.
- C. Plumbing: Alter existing system and add new construction, keeping existing in operation.
- D. Electrical Power and Lighting: Alter existing system and add new construction, keeping existing in operation.
- E. Fire Suppression Sprinklers: Alter existing system and add new construction, keeping existing in operation.
- F. Telephone: Alter existing system and add new construction, keeping existing in operation.
- G. Security System: Alter existing system and add new construction, keeping existing in operation.
- H. Communications: Alter existing system and add new construction, keeping existing in operation.

1.05 WORK BY OWNER

- A. Concurrent Work Under Separate Contracts:
 1. Work Under Separate Contracts: District will award separate contracts for products and installation for interior improvements and other work as may be indicated on Drawings as NIC (Not in Contract).
 2. Relationship to Work Under the Contract:
 - a. Work under the Contract shall include all provisions necessary to make such concurrent work under separate contracts complete in every respect and fully functional, including field finishing.
 - b. Provide necessary backing, supports, piping, conduit, conductors and other such provisions from point of service to point of connection, as shown on Drawings and specified herein.
 3. Related Contract Documents:
 - a. District will make available, in a timely manner, drawings and specifications of work under separate contracts for coordination and further description of that work.

- b. Such drawings and other data required for the coordination of the work of separate contracts with the Work of this Contract may be included with the Contract Documents.
 - c. If so, they are provided for convenience only and are not to be considered Contract Documents produced by Architect or Architect's consultants.
 - 4. Permits, Notices and Fees:
 - a. Permits, Notices and Fees: Notices required by and approvals required of authorities having jurisdiction for work under separate contracts and related fees will be solely the responsibility of District.
- B. Items noted NIC (Not in Contract) will be supplied and installed by District before Substantial Completion.
- C. District will supply the following for installation by Contractor:
 - 1. Owner-Furnished Products: District may furnish, for installation by Contractor, products which are identified on the Drawings and in the Specifications as OFCI (Owner-Furnished/Contractor-Installed).
 - 2. Relationship to Work Under the Contract:
 - a. Work under the Contract shall include all provisions necessary to fully incorporate such products into the Work, including, as necessary.
 - 1) Fasteners.
 - 2) Backing,.
 - 3) Supports.
 - 4) Piping.
 - 5) Conduit.
 - 6) Conductors.
 - 7) Other such provisions from point of service to point of connection.
 - 8) Field finishing, as shown on Drawings and specified herein.
 - b. See Section 01 30 00 - Administrative Requirements for additional requirements.

1.06 PERMITS, LICENSES AND FEES

- A. Permits:
 - 1. For Work included in the Contract, Contractor shall obtain all permits from authorities having jurisdiction and from serving utility companies and agencies.
 - 2. District will reimburse Contractor for amount charged for such permits, without mark-up.
 - 3. For Work performed under design/build basis, plan check and permit fees shall be included in the Contract Sum.
- B. Licenses:
 - 1. Contractor shall obtain and pay all licenses associated with construction activities, such as business licenses, contractors' licenses and vehicle and equipment licenses.
 - 2. All costs for licenses shall be included in the Contract Sum.
- C. Assessments:

1. District will pay all assessments and utility service connection fees. Costs of assessments shall not be included in the Contract Sum.
- D. Test and Inspection Fees:
1. Contractor shall pay all fees charged by authorities having jurisdiction and from serving utility companies and agencies, for tests and inspections conducted by those authorities, companies and agencies.
 2. District will reimburse Contractor for actual amount of such fees, without mark-up.
 3. Refer to Section 01 40 00 - Quality Requirements for additional information on tests and inspections and responsibility for payment of fees.

1.07 OWNER OCCUPANCY

- A. District intends to continue to occupy adjacent portions of the existing site during the entire construction period.
- B. District intends to occupy the Project upon Substantial Completion.
- C. Cooperate with District to minimize conflict and to facilitate District's operations.
- D. Schedule the Work to accommodate District occupancy.

1.08 CONTRACTOR USE OF SITE AND PREMISES

- A. Construction Operations: Limited to areas noted on Drawings.
- B. Arrange use of site and premises to allow:
 1. District occupancy.
 2. Work by Others.
 3. Work by District.
 4. Use of site and premises by the public.
- C. Provide access to and from site as required by law and by District:
 1. Emergency Building Exits During Construction: Keep all exits required by code open during construction period; provide temporary exit signs if exit routes are temporarily altered.
 2. Site Access:
 - a. Limit access to site to indicated routes and access points as indicated.
 - b. If routes and access points are not indicated, access shall be as approved by District.
 - c. Do not restrict access to adjacent properties and do not restrict access for those performing work under separate contracts for the District.
 3. Do not obstruct roadways, sidewalks, or other public ways without permit.
 4. Construction Limit:
 - a. Limit construction activities to areas indicated on Drawings as Project Area or, if not indicated, to areas within the parcel as described in the legal description on the Drawings.
 - b. Refer also to Section 01 50 00 - Temporary Construction Facilities and Controls for additional requirements.
- D. Existing building spaces may not be used for storage.

- E. Time Restrictions:
 - 1. Limit conduct of especially noisy, malodorous, and dusty exterior work to local ordinances.
- F. Utility Outages and Shutdown:
 - 1. Limit disruption of utility services to hours the site is unoccupied.
 - 2. Do not disrupt or shut down life safety systems, including but not limited to fire sprinklers and fire alarm system, without 7 days notice to District and authorities having jurisdiction.
 - 3. Prevent accidental disruption of utility services to other facilities.

1.09 CONSTRUCTION WASTE MANAGEMENT

- A. Construction and waste management, complying with Section 01 74 19 - Construction Waste Management and Disposal, is a requirement for this project.
- B. The Contractor, Prime Contractors, and subcontractors all have obligations in meeting the requirements of this specification.

1.10 SPECIFICATION SECTIONS APPLICABLE TO ALL CONTRACTS

- A. Unless otherwise noted, all provisions of the sections listed in Division 01 apply to all contracts. Specific items of work listed under individual contract descriptions constitute exceptions.

END OF SECTION

SECTION 01 20 00
PRICE AND PAYMENT PROCEDURES

PART 1 GENERAL

1.01 SECTION INCLUDES

- A. Procedures for preparation and submittal of applications for progress payments.
- B. Documentation of changes in Contract Sum and Contract Time.
- C. Change procedures.
- D. Correlation of Contractor submittals based on changes.
- E. Procedures for preparation and submittal of application for final payment.

1.02 RELATED REQUIREMENTS

- A. Section 01 78 00 - Closeout Submittals: Project record documents.

1.03 SCHEDULE OF VALUES

- A. Use Schedule of Values Form:
 - 1. Form provided by District.
- B. Electronic media printout including equivalent information will be considered in lieu of standard form specified; submit draft to Architect for approval.
- C. Forms filled out by hand will not be accepted.
- D. Submit Schedule of Values in duplicate within 15 days after date established in Notice to Proceed.
- E. Format: Utilize the Table of Contents of this Project Manual. Identify each line item with number and title of the specification section. Identify site mobilization.
- F. Include in each line item, the amount of Allowances specified in this section. For unit cost Allowances, identify quantities taken from Contract Documents multiplied by the unit cost to achieve the total for the item.
- G. Include separately from each line item, a direct proportional amount of Contractor's overhead and profit.
- H. Revise schedule to list approved Change Orders, with each Application For Payment.
 - 1. List each authorized Change Order as an extension on the continuation sheet, listing the Change Order number and dollar value as for an original portion of Work.

1.04 APPLICATIONS FOR PROGRESS PAYMENTS

- A. Payment Period: Submit at intervals stipulated in the Agreement.
 - 1. Substantiating information will normally be required only for those portions of Work whose completion state cannot be readily determined by observation of the completed Work.
- B. Use Form AIA G702 and Form AIA G703, edition stipulated in the Agreement.

- C. Electronic media printout including equivalent information will be considered in lieu of standard form specified; submit sample to Architect for approval.
- D. Forms filled out by hand will not be accepted.
- E. For each item, provide a column for listing each of the following:
 - 1. Item Number.
 - 2. Description of work.
 - 3. Scheduled Values.
 - 4. Previous Applications.
 - 5. Work in Place and Stored Materials under this Application.
 - 6. Authorized Change Orders.
 - 7. Total Completed and Stored to Date of Application.
 - 8. Balance to Finish.
 - 9. Retainage.
- F. Execute certification by signature of authorized officer.
- G. Use data from approved Schedule of Values. Provide dollar value in each column for each line item for portion of work performed and for stored products.
- H. List each authorized Change Order as a separate line item, listing Change Order number and dollar amount as for an original item of work.
 - 1. No Change Orders shall be included with Application for Payment until approved in writing by District and Architect. Also approved by DSA when appropriate.
- I. Submit one electronic and three hard-copies of each Application for Payment.
- J. Include the following with the application:
 - 1. Transmittal letter as specified for submittals in Section 01 30 00.
 - 2. Construction progress schedule, revised and current as specified in Section 01 30 00.
 - 3. Current construction photographs specified in Section 01 30 00.
 - 4. Partial release of liens from major subcontractors and vendors.
 - a. Provide with each Application for Payment lien releases from all subcontractors, workers and materials suppliers employed for the Project covering their portion of Work to date for which payment application is made. Lien release forms will be provided by District and shall be completed in accordance with directions provided.
 - 5. Project record documents as specified in Section 01 78 00, for review by District which will be returned to the Contractor.
 - 6. Affidavits attesting to off-site stored products.
- K. When Architect requires substantiating information, submit data justifying dollar amounts in question. Provide one copy of data with cover letter for each copy of submittal. Show application number and date, and line item by number and description.

1.05 ADDENDA

- A. Addenda are changes issued prior to the signing of the Contract for Construction. These Addenda shall be signed by the Architect and approved by the Division of the State Architect.

- B. These documents may or may not have approved by the Division of the State Architect prior to the close of Bid.
 - 1. If not approved by DSA prior to close of the bidding period, the contract price shall include the Addenda.
 - 2. No work shall proceed regarding any Addendum until approved by DSA.
 - 3. Revisions to Addenda, when approved by DSA, shall be incorporated by an additional addendum or Change Order as indicated below and as provided for in the Contract for Construction and General Conditions.

1.06 MODIFICATION PROCEDURES

- A. Construction Changes, General:
 - 1. The following describe administrative procedures to be followed in compliance with provisions of the Conditions of the Contract for Architect's Supplemental Instructions, Construction Change Directives, Construction Change Documents, and Contract Change Orders.
 - 2. The Architect will prepare and issue: Architect's Supplemental Instructions, a Construction Change Directive or a Request for Proposal to be presented to the Contractor for action.
- B. Submit name of the individual authorized to receive change documents and who will be responsible for informing others in Contractor's employ or subcontractors of changes to Contract Documents.
- C. Contract Change Order Forms: Form as directed by District.
- D. For minor changes not involving an adjustment to the Contract Sum or Contract Time, Architect will issue instructions directly to Contractor.
 - 1. Architect's Supplemental Instructions:
 - a. Minor changes in the Work, not involving an adjustment in either the Contract Sum or Contract Time, as authorized by the Conditions of the Contract, will be presented by the Architect using the Architect's Bulletin form.
 - b. Should the Architect's Supplemental Instructions result in disputed costs and time adjustments, such dispute shall be resolved in accordance with the provisions of the Conditions of the Contract.
- E. DSA Construction Change Document approval for substitutions and changes to structural, accessibility, or fire-life-safety portions of approved Drawings and Specifications is required from DSA prior to fabrication and installation. DSA IR A-6; CAC Section 4-215, & 4-233(c).
 - 1. The approved Construction Change Document shall be signed by:
 - a. Architect of Record.
 - b. When applicable:
 - 1) Structural Engineer of Record.
 - 2) Mechanical Engineer of Record.
 - 3) Electrical Engineer of Record.
 - 4) Civil Engineer of Record.
 - 5) Delegated Professional Engineer.
 - c. Division of the State Architect for final approval.

- F. For other required changes, not involving structural, accessibility, or fire-life-safety portions of approved Drawings and Specifications, Architect will issue a document signed by District instructing Contractor to proceed with the change, for subsequent inclusion in a Change Order.
1. The document will describe the required changes and will designate method of determining any change in Contract Sum or Contract Time.
 2. Promptly execute the change.
 3. Construction Change Directives: In accordance with provisions of the Conditions of the Contract, the District may direct the Contractor to proceed with a change in the Work prior to formal preparation, review and agreement of a Contract Change Order, in order to not delay construction.
 - a. The Architect will prepare and issue a change document containing a Construction Change Directive which, when signed by the District and the Architect, shall instruct the Contractor to proceed with a change in the Work, for subsequent inclusion in a Contract Change Order.
 - b. Should the Construction Change Directive result in disputed costs and time adjustments, such dispute shall be resolved in accordance with the provisions of the Conditions of the Contract.
 - c. Construction Change Directives shall follow procedures specified below for Contract Change Orders except that Contractor shall immediately proceed with the change upon receipt of the signed Change Directive.
- G. For changes for which advance pricing is desired, Architect will issue a document that includes a detailed description of a proposed change with supplementary or revised drawings and specifications, a change in Contract Time for executing the change with a stipulation of any overtime work required and the period of time during which the requested price will be considered valid. Contractor shall prepare and submit a fixed price quotation within 14 days.
1. Such Request for Proposal may include an estimate of additions or deductions in Contract Time and Contract Sum for executing the change and may include stipulations regarding overtime work and the period of time the requested response from the Contractor shall be considered valid.
- H. Contractor may propose a change by submitting a request for change to Architect, describing the proposed change and its full effect on the work, with a statement describing the reason for the change, and the effect on the Contract Sum and Contract Time with full documentation and a statement describing the effect on work by separate or other contractors. Document any requested substitutions in accordance with Section 01 60 00.
1. After review of the request and with the District's approval, the Architect will prepare a change document containing a Request for Proposal, as described above.
 2. Issuance of such a request by the Architect shall not indicate authorization of the Contractor to proceed with the proposed change.
 3. Changes will be approved only by an approved Construction Change Directive and Contract Change Order.
- I. Computation of Change in Contract Amount: As specified in the Agreement and Conditions of the Contract.

1. For change requested by Architect for work falling under a fixed price contract, the amount will be based on Contractor's price quotation.
 2. For change requested by Contractor, the amount will be based on the Contractor's request for a Change Order as approved by Architect.
 3. For pre-determined unit prices and quantities, the amount will be based on the fixed unit prices.
 4. For change ordered by Architect without a quotation from Contractor, the amount will be determined by Architect based on the Contractor's substantiation of costs as specified for Time and Material work.
- J. Substantiation of Costs: Provide full information required for evaluation.
1. On request, provide the following data:
 - a. Quantities of products, labor, and equipment.
 - b. Taxes, insurance, and bonds.
 - c. Overhead and profit.
 - d. Justification for any change in Contract Time.
 - e. Credit for deletions from Contract, similarly documented.
 2. Support each claim for additional costs with additional information:
 - a. Origin and date of claim.
 - b. Dates and times work was performed, and by whom.
 - c. Time records and wage rates paid.
 - d. Invoices and receipts for products, equipment, and subcontracts, similarly documented.
 3. For Time and Material work, submit itemized account and supporting data after completion of change, within time limits indicated in the Conditions of the Contract.
 - a. Cost and Time Resolution: If amounts for changes in Contract Sum and Contract Time cannot be agreed upon by District and Contractor, amounts shall be resolved in accordance with provisions of the Conditions of the Contract for resolution of disputes and the following:
 - 1) Contractor shall keep accurate records of time, both labor and calendar days, and cost of materials and equipment.
 - 2) Contractor shall prepare and submit an itemized account and supporting data after completion of changed Work, within the time limits indicated in the Conditions of the Contract.
 - 3) Contractor shall provide full information as required and requested, for District and Architect to evaluate and substantiate proposed costs and time for the change in the Work.
 - 4) When District and Contractor determine mutually acceptable amounts for changes in Contract Sum and Contract Time, a Contract Change Order shall be executed for these amounts.
 - 5) District shall have the right to audit Contractor's invoices and bid quotations to substantiate costs for Contract Change Orders.

- K. Construction Changes Based on Stipulated Sum or Time: Based on the Contractor's response to a Request for Proposal or Construction Change Directive, the District and Architect will review the response.
 - 1. The District and Contractor shall negotiate a mutually acceptable adjustment in Contract Sum and Contract Time, as appropriate, prior to performance of the changed Work.
 - 2. A Contract Change Order for the stipulated amounts shall be prepared based on the stipulated sum and change in time.
- L. Execution of Change Orders: Architect will issue Change Orders for signatures of parties as provided in the Conditions of the Contract.
 - 1. When agreement is reached on changes, if any, in the Contract Time and the Contract Sum, the Contractor shall prepare a Contract Change Order using a form as directed by the District, with supplementary documents as necessary to describe the change and the associated costs and schedule impacts.
 - 2. Construction Change Document approval is required from DSA prior to fabrication and installation.
 - 3. Submit Contract Change Orders to District through the Architect.
 - 4. Contractor shall prepare and submit five original sets of documents for each Change Order. District, Architect and Construction Manager shall sign the Change Order indicating acceptance and approval of the change.
 - a. Structural Engineer shall also sign the Change Order, when applicable.
 - 5. All Change Orders must be approved by DSA prior to fabrication and installation.
 - 6. Upon approval of the Change Order, Contractor shall promptly execute the change in the Work.
- M. After execution of Change Order, promptly revise Schedule of Values and Application for Payment forms to record each authorized Change Order as a separate line item and adjust the Contract Sum.
- N. Promptly revise progress schedules to reflect any change in Contract Time, revise sub-schedules to adjust times for other items of work affected by the change, and resubmit.
 - 1. Contractor shall submit revised schedules at the next Application for Payment following approval and acceptance of the Contract Change Order.
- O. Promptly enter changes in Project Record Documents.

1.07 APPLICATION FOR FINAL PAYMENT

- A. Prepare Application for Final Payment as specified for progress payments, identifying total adjusted Contract Sum, previous payments, and sum remaining due.
- B. Application for Final Payment will not be considered until the following have been accomplished:
 - 1. All closeout procedures specified in Section 01 70 00.

PART 2 PRODUCTS - NOT USED

PART 3 EXECUTION - NOT USED

END OF SECTION

SECTION 01 25 00
SUBSTITUTION PROCEDURES

PART 1 GENERAL

1.01 SECTION INCLUDES

- A. Procedural requirements for proposed substitutions.

1.02 RELATED REQUIREMENTS

- A. Division 00 - Procurement and Contracting Requirements: Restrictions on timing of substitution requests.
- B. Section 00 43 25 - Substitution Request Form - During Procurement: Required form for substitution requests made prior to award of contract (During procurement).
- C. Section 00 63 25 - Substitution Request Form - During Construction: Required form for substitution requests made after award of contract (During construction).
- D. Section 01 30 00 - Administrative Requirements: Submittal procedures, coordination.
- E. Section 01 60 00 - Product Requirements: Fundamental product requirements, product options, delivery, storage, and handling.
- F. Section 01 61 16 - Volatile Organic Compound (VOC) Content Restrictions: Restrictions on emissions of indoor substitute products.

1.03 DEFINITIONS

- A. Substitutions: Changes from Contract Documents requirements proposed by Contractor to materials, products, assemblies, and equipment.
 - 1. Substitutions for Cause: Proposed due to changed Project circumstances beyond Contractor's control.
 - a. Unavailability.
 - b. Regulatory changes.
 - 2. Substitutions for Convenience: Proposed due to possibility of offering substantial advantage to the Project.
 - a. Substitution requests offering advantages solely to the Contractor will not be considered.

PART 2 PRODUCTS - NOT USED

PART 3 EXECUTION

3.01 GENERAL REQUIREMENTS

- A. Requests by Contractor to deviate from specified requirements for products, materials, equipment, and methods, or to provide products other than those specified, shall be considered requests for substitutions except under the following conditions:
 - 1. Substitutions are requested during the bidding period, and accepted prior to execution of the Contract. Acceptance shall be in the form of written Addendum to the Bidding

- documents or revision to the Drawings or Specifications for use as Construction Contract Documents.
2. Changes in products, materials, equipment, and methods of construction are directed by the District or Architect.
 3. Contractor options for provision of products and construction methods are specifically stated in the Contract Documents.
 4. Change in products, materials, equipment, and methods of construction is required for compliance with Codes, ordinances, regulations, orders and standards of authorities having jurisdiction.
- B. Substitution Provisions: Refer to substitution provisions of the Conditions of the Contract, in addition to the requirements specified herein. Provisions for consideration and acceptance of substitutions shall be as follows:
1. Documentation:
 - a. Substitutions will not be considered if they are indicated or implied on shop drawing, product data or sample submittals.
 - b. All requests for substitution shall be made by separate written request from Contractor.
 2. Cost and Time Considerations: Substitutions will not be considered unless a net reduction in Contract Sum or Contract Time results to the District's benefit, including redesign costs, life cycle costs, changes in related Work and overall performance of building systems.
 3. Design Revision:
 - a. Substitutions will not be considered if acceptance will require substantial revision of the Contract Documents or will substantially change the intent of the design, in the opinion of the Architect.
 - b. The intent of the design shall include functional performance and aesthetic qualities.
 4. Data: It shall be the responsibility of the Contractor to provide adequate data demonstrating the merits of the proposed substitution, including cost data and information regarding changes in related Work.
 5. Determination by Architect:
 - a. Architect will determine the acceptability of proposed substitutions and will notify Contractor, in writing within a reasonable time, of acceptance or rejection.
 - b. The determination by the Architect regarding functional performance and aesthetic quality shall be final.
 6. Non-Acceptance: If a proposed substitution is not accepted, provide the specified product.
 - a. If, in the opinion of the Architect, the substitution request is incomplete or has insufficient data to enable a full and thorough review of the intended substitution, the substitution may be summarily refused and determined to be unacceptable.
 7. Substitution Limitation: Only one request for substitution will be considered for each product.

- C. A Substitution Request for products, assemblies, materials, and equipment constitutes a representation that the submitter:
 - 1. Has investigated proposed product and determined that it meets or exceeds the quality level of the specified product, equipment, assembly, or system.
 - a. Include a signed certification that the Contractor has:
 - 1) Reviewed the proposed substitution and has determined that the substitution is equivalent or superior in every respect to product requirements indicated or product specified in the Contract Documents.
 - 2) Certify the proposed substitution is suited for and can perform the purpose or application of the specified product indicated or specified in the Contract Documents.
 - 2. Agrees to provide the same warranty for the substitution as for the specified product.
 - 3. Agrees to provide same or equivalent maintenance service and source of replacement parts, as applicable.
 - 4. Agrees to coordinate installation and make changes to other work that may be required for the work to be complete, with no additional cost to District.
 - 5. Waives claims for additional costs or time extension that may subsequently become apparent.
 - a. Include a signed waiver by the Contractor for changes in the Contract Time or Contract Sum because of the following:
 - 1) Substitution failed to perform adequately.
 - 2) Substitution required changes in on other elements of the Work.
 - 3) Substitution caused problems in interfacing with other elements of the Work.
 - 4) Substitution was determined to be unacceptable by authorities having jurisdiction.
 - 6. Agrees to reimburse District and Architect for review or redesign services associated with re-approval by authorities.
- D. A Substitution Request for specified installer constitutes a representation that the submitter:
 - 1. Has acted in good faith to obtain services of specified installer, but was unable to come to commercial, or other terms.
- E. Document each request with complete data substantiating compliance of proposed substitution with Contract Documents. Burden of proof is on proposer.
 - 1. Note explicitly any non-compliant characteristics.
- F. Content: Include information necessary for tracking the status of each Substitution Request, and information necessary to provide an actionable response.
 - 1. Forms indicated and included in the Project Manual are adequate for this purpose, and must be used.
 - 2. No specific form is required. Contractor's Substitution Request documentation must include the following:
 - a. Project Information:
 - 1) Official project name and number, and any additional required identifiers established in Contract Documents.
 - 2) District's, Architect's, and Contractor's names.

- b. Substitution Request Information:
 - 1) Discrete and consecutive Substitution Request number, and descriptive subject/title.
 - 2) Indication of whether the substitution is for cause or convenience.
 - 3) Issue date.
 - 4) Reference to particular Contract Document(s) specification section number, title, and article/paragraph(s).
 - 5) Description of Substitution.
 - 6) Reason why the specified item cannot be provided.
 - 7) Differences between proposed substitution and specified item.
 - 8) Description of how proposed substitution affects other parts of work.
 - c. Attached Comparative Data: Provide point-by-point, side-by-side comparison addressing essential attributes specified, as appropriate and relevant for the item:
 - 1) Physical characteristics.
 - 2) In-service performance.
 - 3) Expected durability.
 - 4) Visual effect.
 - 5) Sustainable design features.
 - 6) Warranties.
 - 7) Other salient features and requirements.
 - 8) Include, as appropriate or requested, the following types of documentation:
 - (a) Product Data:
 - (b) Samples.
 - (c) Certificates, test, reports or similar qualification data.
 - (d) Drawings, when required to show impact on adjacent construction elements.
 - 9) Include a detailed description, in written or graphic form as appropriate, indicating all changes or modifications needed to other elements of the Work and to construction to be performed by the District and by others under separate Contract with District, that will be necessary if the proposed substitution is accepted.
 - d. Impact of Substitution:
 - 1) Savings to District for accepting substitution.
 - (a) Include detailed cost data, including a proposal for the net change, if any, in the Contract Sum.
 - 2) Change to Contract Time due to accepting substitution.
 - (a) Indicate the substitution's effect on the Construction Schedule. Indicate the effect of the proposed substitution on overall Contract Time and, as applicable, on completion of portions of the Work for use by District or for work under separate contract by District.
- G. Limit each request to a single proposed substitution item.
- 1. Submit an electronic document, combining the request form with supporting data into single document.

3.02 SUBSTITUTION PROCEDURES DURING PROCUREMENT

- A. Instructions to Bidders specifies time restrictions for submitting requests for substitutions during the bidding period, and the documents required.
- B. Pursuant to Section 3400 of the Public Contract Code, requests for substitution will be considered only if received up to 7 days prior to the bid date. Subsequent requests will be considered only in the case of product unavailability, through no fault of the Contractor , or for reasons of cost reducing value analysis requested by the District .
- C. Submittal Form (before award of contract):
 - 1. Submit substitution requests by completing the form in Section 00 43 25; see this section for additional information and instructions. Use only this form; other forms of submission are unacceptable.

3.03 SUBSTITUTION PROCEDURES DURING CONSTRUCTION

- A. Submittal Form (after award of contract):
 - 1. Submit substitution requests by completing the form in Section 00 63 25; see this section for additional information and instructions. Use only this form; other forms of submission are unacceptable.
- B. After Contract award, requests will be considered for cause only; in the case of product unavailability, through no fault of the Contractor , or for reasons of cost reducing value analysis requested by the District.
 - 1. Substitutions will be considered when a product, through no fault of the Contractor, becomes unavailable or unsuitable due to regulatory change.
 - 2. Product Availability Waiver:
 - a. Substitutions will be considered after 35 day time limit only when a product becomes unavailable due to no fault of Contractor.
 - b. Failure to place orders for specified products sufficiently in advance of required date for incorporation into the Work will not be considered as a valid reason for which Contractor may request a substitution or deviation from requirements of the Drawings and Specifications.
 - 3. Waiver: At the discretion of the District, limitations on substitutions may be waived.
- C. Submit request for Substitution for Cause within 14 days of discovery of need for substitution, but not later than 14 days prior to time required for review and approval by Architect, in order to stay on approved project schedule.
- D. Submit request for Substitution for Convenience immediately upon discovery of its potential advantage to the project, but not later than 14 days prior to time required for review and approval by Architect, in order to stay on approved project schedule.
 - 1. In addition to meeting general documentation requirements, document how the requested substitution benefits the District through cost savings, time savings, greater energy conservation, or in other specific ways.
 - 2. Document means of coordinating of substitution item with other portions of the work, including work by affected subcontractors.
 - 3. Bear the costs engendered by proposed substitution of:

- a. District's compensation to the Architect for any required redesign, time spent processing and evaluating the request.
 - b. Other construction by District.
 - c. Other unanticipated project considerations.
- E. Substitutions will not be considered under one or more of the following circumstances:
- 1. When they are indicated or implied on shop drawing or product data submittals, without having received prior approval.
 - 2. Without a separate written request.
 - 3. When acceptance will require revisions to Contract Documents.

3.04 CONTRACT DOCUMENT REVISIONS:

- A. Should a Contractor-proposed substitution or alternative sequence or method of construction require revision of the Contract Drawings or Specifications;
 - 1. Including revisions for the purposes of determining feasibility, scope or cost, or revisions for the purpose of obtaining review and approval by authorities having jurisdiction.
 - 2. Revisions will be made by Architect or other consultant of District who is the responsible design professional, as approved in advance by District.
- B. Services of Architect or other consultant of the District, including time spent in researching and reporting on proposed substitutions or alternative sequence and method of construction, shall be paid by Contractor when such activities are considered additional services to the design services contracts of the Architect or other responsible design professional with the District.
- C. Costs of services by Architect or other responsible design professional of the District shall be paid on a time and materials basis, based on current hourly fee schedules, with reproduction, long distance telephone and shipping costs reimbursable at cost plus usual and customary mark-up for handling and billing.
- D. Such fees shall be paid whether or not the proposed substitution or alternative sequence or method of construction is ultimately accepted by District and a Change Order is executed.
- E. Such fees shall be paid from Contractor's portion of savings, if a net reduction in Contract Sum results. If fees exceed Contractor's portion of net reduction, Contractor shall pay all remaining fees unless otherwise agreed in advance by the District.
- F. Such fees owed shall be deducted from the amount owed Contractor on the Application for Payment next made following completion of revised Contract Drawings and Specifications or completion of research and other services. District will then pay Architect or other consultant of the District.
- G. Certain substitutions require approval from DSA.

3.05 RESOLUTION

- A. Architect may request additional information and documentation prior to rendering a decision. Provide this data in an expeditious manner.
- B. Architect will notify Contractor in writing of decision to accept or reject request.
 - 1. Architect's decision following review of proposed substitution will be noted on the submitted form.

3.06 ACCEPTANCE

- A. Accepted substitutions change the work of the Project. They will be documented and incorporated into work of the project by Change Order, Construction Change Directive, Architectural Supplementary Instructions, or similar instruments provided for in the Conditions of the Contract.

3.07 CLOSEOUT ACTIVITIES

- A. See Section 01 78 00 - Closeout Submittals, for closeout submittals.
- B. Include completed Substitution Request Forms as part of the Project record. Include both approved and rejected Requests.

3.08 ATTACHMENTS

- A. A facsimile of the Substitution Request Form (During Construction) required to be used on the Project is included after this section.

END OF SECTION

SECTION 01 30 00
ADMINISTRATIVE REQUIREMENTS

PART 1 GENERAL

1.01 SECTION INCLUDES

- A. General administrative requirements.
- B. Electronic document submittal service.
- C. Preconstruction meeting.
- D. Site mobilization meeting.
- E. Progress meetings.
- F. Construction progress schedule.
- G. Contractor's daily reports.
- H. Progress photographs.
- I. Coordination drawings.
- J. Submittals for review, information, and project closeout.
- K. Number of copies of submittals.
- L. Requests for Interpretation or Information (RFI) procedures.
- M. Submittal procedures.

1.02 RELATED REQUIREMENTS

- A. Section 01 60 00 - Product Requirements: General product requirements.
- B. Section 01 70 00 - Execution and Closeout Requirements: Additional coordination requirements.
- C. Section 01 78 00 - Closeout Submittals: Project record documents; operation and maintenance data; warranties and bonds.
- D. Technical Product Sections: Procedures for specific submittals specified in those Sections to be made at Contract closeout.

1.03 DEFINITIONS

- A. Action Submittals: Written and graphic information that requires responsive action by Construction Manager and Architect or other responsible design professional.
- B. Informational Submittals: Written information that does not require responsive action by Construction Manager and Architect or other responsible design professional.
- C. Unsolicited Submittals: Action or informational submittals not required by the Contract Documents or not requested by the reviewer. Unsolicited submittals may be returned with notation "not reviewed."
- D. Product Data: Standard published information ("catalog cuts") and specially prepared data for the Work of the Contract, including standard illustrations, schedules, brochures, diagrams, performance charts, instructions and other information to illustrate a portion of the Work.

- E. Request for Interpretation or Information (RFI): A document submitted by the Contractor requesting clarification of a portion of the Contract Documents, hereinafter referred to as an RFI.
- F. Samples: Physical examples that demonstrate the materials, finishes, features, workmanship and other characteristics of a portion of the Work. Accepted samples shall serve as quality basis for evaluating the Work.
- G. Shop Drawings, Product Data and Samples: Instruments prepared and submitted by Contractor, for Contractor's benefit, to communicate to Architect the Contractor's understanding of the design intent, for review and comment by Architect on the conformance of the submitted information to the general intent of the design. Shop drawings, product data and samples are not Contract Documents.
- H. Shop Drawings: Drawings, diagrams, schedules and illustrations, with related notes, specially prepared for the Work of the Contract, to illustrate a portion of the Work.
- I. Other Submittals: Technical data, test reports, calculations, surveys, certifications, special warranties and guarantees, operation and maintenance data, extra stock and other submitted information and products shall not be considered as Contract Documents but shall be information from Contractor to Architect to illustrate a portion of the Work for confirmation of understanding of design intent.

1.04 GENERAL ADMINISTRATIVE REQUIREMENTS

- A. Comply with requirements of Section 01 70 00 - Execution and Closeout Requirements for coordination of execution of administrative tasks with timing of construction activities.
- B. Make the following types of submittals to Architect:
 - 1. Requests for Interpretation or Information (RFI).
 - 2. Requests for substitution.
 - 3. Shop drawings, product data, and samples.
 - 4. Test and inspection reports.
 - 5. Design data.
 - 6. Manufacturer's instructions and field reports.
 - 7. Applications for payment and change order requests.
 - 8. Progress schedules.
 - 9. Coordination drawings.
 - 10. Correction Punch List and Final Correction Punch List for Substantial Completion.
 - 11. Closeout submittals.

PART 2 PRODUCTS - NOT USED

PART 3 EXECUTION

3.01 ELECTRONIC DOCUMENT SUBMITTAL SERVICE

- A. All documents transmitted for purposes of administration of the contract are to be in electronic (PDF, MS Word, or MS Excel) format, as appropriate to the document, and transmitted via an Internet-based submittal service that receives, logs and stores documents, provides electronic stamping and signatures, and notifies addressees via email.
 - 1. Besides submittals for review, information, and closeout, this procedure applies to Requests for Interpretation or Information (RFIs), progress documentation, contract modification documents (e.g. supplementary instructions, change proposals, change orders), applications for payment, field reports and meeting minutes, Contractor's correction punchlist, and any other document any participant wishes to make part of the project record.
 - 2. Contractor and Architect are required to use this service.
 - 3. It is Contractor's responsibility to submit documents in allowable format.
 - 4. Subcontractors, suppliers, and Architect's consultants are to be permitted to use the service at no extra charge.
 - 5. Users of the service need an email address, internet access, and PDF review software that includes ability to mark up and apply electronic stamps (such as Adobe Acrobat, www.adobe.com, or Bluebeam PDF Revu, www.bluebeam.com), unless such software capability is provided by the service provider.
 - 6. Unless specifically requested, paper document transmittals will not be reviewed; emailed electronic documents will not be reviewed.
 - 7. All other specified submittal and document transmission procedures apply, except that electronic document requirements do not apply to samples or color selection charts.
- B. Cost: The cost of the service is to be paid by Contractor; include the cost of the service in the Contract Sum.
- C. Submittal Service: The selected service is:
 - 1. Bluebeam Software Inc.; Bluebeam Revu Studio: www.bluebeam.com.
 - 2. Other Service acceptable to both District and Architect.
 - a. Direct email with PDF copies.
- D. Training: One, one-hour, web-based training session will be arranged for all participants, with representatives of Architect and Contractor participating; further training is the responsibility of the user of the service.
 - 1. Representatives of District are scheduled and included in this training.
- E. Project Closeout: Architect will determine when to terminate the service for the project and is responsible for obtaining archive copies of files for District.

3.02 PRECONSTRUCTION MEETING

- A. District will schedule a meeting after Notice of Award.
- B. Attendance Required:
 - 1. District.
 - 2. Architect.
 - 3. Contractor.
- C. Agenda:
 - 1. Execution of District-Contractor Agreement.
 - 2. Submission of executed bonds and insurance certificates.
 - 3. Distribution of Contract Documents.
 - 4. Submission of list of subcontractors, list of products, schedule of values, and progress schedule.
 - 5. Submission of initial Submittal schedule.
 - 6. Designation of personnel representing the parties to Contract and Architect.
 - 7. Procedures and processing of field decisions, submittals, substitutions, applications for payments, proposal request, Change Orders, and Contract closeout procedures.
 - 8. Scheduling.
 - 9. Scheduling activities of a Geotechnical Engineer.
- D. Record minutes and distribute copies within two days after meeting to participants, with two copies to Architect, District, participants, and those affected by decisions made.

3.03 SITE MOBILIZATION MEETING

- A. Schedule meeting at the Project site prior to Contractor occupancy.
- B. Attendance Required:
 - 1. Contractor.
 - 2. District.
 - 3. Architect.
 - 4. Contractor's superintendent.
 - 5. Major subcontractors.
 - 6. Inspector of Record.
- C. Agenda:
 - 1. Distribute and discuss list of subcontractors and suppliers.
 - 2. Project Communication Procedures: Review requirements and administrative requirements for written and oral communications.
 - a. Review requirements and administrative procedures Contractor may wish to institute for identification and reporting purposes.

3. Change Procedures: Review requirements and administrative procedures for Change Orders, Construction Change Directives, Architect's supplemental instructions and Contractor's Requests for Interpretation or Information.
 4. Use of premises by District and Contractor.
 - a. Site access restrictions, if any, and requirements to avoid disruption of operations at adjoining facilities or operations.
 - b. Construction Facilities and Temporary Utilities: Designate storage and staging areas, construction office areas; review temporary utility provisions; present District's requirements for use of premises.
 5. District's requirements.
 6. Construction facilities and controls provided by District.
 7. Temporary utilities provided by District.
 8. Survey and building layout.
 9. Security and housekeeping procedures.
 10. Schedules.
 - a. Distribute and discuss initial construction schedule and critical work sequencing of major elements of Work;
 - b. Include coordination of District Furnished / Contractor Installed (OFCI) products;
 11. Application for payment procedures.
 12. Procedures for testing.
 13. Procedures for maintaining record documents.
 14. Requirements for start-up of equipment.
 15. Inspection and acceptance of equipment put into service during construction period.
- D. Record minutes and distribute copies within two days after meeting to participants, with two copies to Architect, District, participants, and those affected by decisions made.

3.04 PROGRESS MEETINGS

- A. Schedule and administer meetings throughout progress of the work at maximum bi-weekly intervals.
- B. Meeting Time and Location: As mutually agreed by District, Architect, and Contractor, at on-site location.
- C. Special Meetings: As necessary, Construction Manager may convene special meetings to discuss specific construction issues in detail and to plan specific activities.
 1. See Section 01 70 00 - Execution and Closeout Requirements.
- D. Attendance Required:
 1. Contractor.
 2. District.
 3. Architect.
 4. Contractor's superintendent.
 5. Major subcontractors.

6. Inspector of Record.
- E. Agenda:
1. Review minutes of previous meetings.
 2. Review of work progress.
 3. Field observations, problems, and decisions.
 4. Identification of problems that impede, or will impede, planned progress.
 5. Review of submittals schedule and status of submittals.
 6. Review of RFIs log and status of responses.
 7. Review of off-site fabrication and delivery schedules.
 8. Maintenance of progress schedule.
 9. Corrective measures to regain projected schedules.
 - a. Develop corrective measures and procedures, including but not necessarily limited to additional personnel loading to regain planned schedule.
 10. Planned progress during succeeding work period.
 11. Coordination of projected progress.
 12. Maintenance of quality and work standards.
 13. Effect of proposed changes on progress schedule and coordination.
 14. Other business relating to work.
- F. Record minutes and distribute copies within two days after meeting to participants, with copies to Architect, District, participants, and those affected by decisions made.

3.05 CONSTRUCTION PROGRESS SCHEDULE

- A. Within 10 days after date of the Agreement, submit preliminary schedule defining planned operations for the first 60 days of work, with a general outline for remainder of work.
- B. Contractor's Review: All schedules shall be reviewed and approved by Contractor prior to submission for Architect's and Construction Manager's review.
- C. Reviews by Architect and Construction Manager will be to ascertain the general status of construction and shall not be interpreted to establish or approve the means, methods, techniques and sequences of construction.
- D. If preliminary schedule requires revision after review, submit revised schedule within 10 days.
- E. Within 20 days after review of preliminary schedule, submit draft of proposed complete schedule for review.
 1. Include written certification that major contractors have reviewed and accepted proposed schedule.
- F. Within 10 days after joint review, submit complete schedule.
- G. Submit updated schedule with each Application for Payment.

3.06 DAILY CONSTRUCTION REPORTS

- A. Include only factual information. Do not include personal remarks or opinions regarding operations and/or personnel.

- B. In addition to transmitting electronically a copy to District and Architect, submit two printed copies at weekly intervals.
 - 1. Submit in format acceptable to District.
 - 2. Submit using required form, a sample of which is appended to this section.
- C. Prepare a daily construction report recording the following information concerning events at Project site and project progress:
 - 1. Date.
 - 2. High and low temperatures, and general weather conditions.
 - 3. List of subcontractors at Project site.
 - 4. List of separate contractors at Project site.
 - 5. Approximate count of personnel at Project site.
 - a. Include a breakdown for supervisors, laborers, journeymen, equipment operators, and helpers.
 - 6. Major equipment at Project site.
 - 7. Material deliveries.
 - 8. Safety, environmental, or industrial relations incidents.
 - 9. Meetings and significant decisions.
 - 10. Unusual events (submit a separate special report).
 - 11. Stoppages, delays, shortages, and losses. Include comparison between scheduled work activities (in Contractor's most recently updated and published schedule) and actual activities. Explain differences, if any. Note days or periods when no work was in progress and explain the reasons why.
 - 12. Meter readings and similar recordings.
 - 13. Emergency procedures.
 - 14. Directives and requests of Authority(s) Having Jurisdiction (AHJ).
 - 15. Change Orders received and implemented.
 - 16. Testing and/or inspections performed.
 - 17. List of verbal instruction given by District and/or Architect.
 - 18. Signature of Contractor's authorized representative.

3.07 PROGRESS PHOTOGRAPHS

- A. Submit photographs with each application for payment, taken not more than 3 days prior to submission of application for payment.
- B. Maintain one set of all photographs at project site for reference; same copies as submitted, identified as such.
- C. Photography Type: Digital; electronic files.
- D. Provide photographs of site and construction throughout progress of work produced by an experienced photographer, acceptable to Architect.
- E. In addition to periodic, recurring views, take photographs of each of the following events:

1. Completion of site clearing.
 2. Excavations in progress.
 3. Foundations in progress and upon completion.
 4. Structural framing in progress and upon completion.
 5. Enclosure of building, upon completion.
 6. Final completion, minimum of ten (10) photos.
- F. Take photographs as evidence of existing project conditions as follows:
1. Interior views: each elevation, floor and ceilings prior to demolition.
 2. Exterior views: each elevation, roof and areas adjacent to construction limits.
- G. Views:
1. Provide non-aerial photographs from four cardinal views at each specified time, until date of Substantial Completion.
 2. Consult with Architect for instructions on views required.
 3. Provide factual presentation.
 4. Provide correct exposure and focus, high resolution and sharpness, maximum depth of field, and minimum distortion.
 5. Point of View Sketch: Provide sketch identifying point of view of each photograph.
- H. Digital Photographs: 24 bit color, minimum resolution of 1024 by 768, in JPG format; provide files unaltered by photo editing software.
1. Delivery Medium: Via email.
 2. File Naming: Include project identification, date and time of view, and view identification.
 3. Point of View Sketch: Include digital copy of point of view sketch with each electronic submittal; include point of view identification in each photo file name.
 4. PDF File: Assemble all photos into printable pages in PDF format, with 2 to 3 photos per page, each photo labeled with file name; one PDF file per submittal.
 5. Hard Copy: Printed hardcopy (grayscale) of PDF file and point of view sketch.

3.08 COORDINATION DRAWINGS

- A. See Section 01 31 14 - Facility Services Coordination.
- B. Provide information required by Project Coordinator for preparation of coordination drawings.
- C. Review drawings prior to submission to Architect.

3.09 REQUESTS FOR INTERPRETATION OR INFORMATION (RFI)

- A. Definition: A request seeking one of the following:
 1. An interpretation, amplification, or clarification of some requirement of Contract Documents arising from inability to determine from them the exact material, process, or system to be installed; or when the elements of construction are required to occupy the

same space (interference); or when an item of work is described differently at more than one place in the Contract Documents.

2. A resolution to an issue which has arisen due to field conditions and affects design intent.
- B. Whenever possible, request clarifications at the next appropriate project progress meeting, with response entered into meeting minutes, rendering unnecessary the issuance of a formal RFI.
- C. Preparation: Prepare an RFI immediately upon discovery of a need for interpretation of Contract Documents. Failure to submit a RFI in a timely manner is not a legitimate cause for claiming additional costs or delays in execution of the work.
 1. Prepare a separate RFI for each specific item.
 - a. Review, coordinate, and comment on requests originating with subcontractors and/or materials suppliers.
 - b. Do not forward requests which solely require internal coordination between subcontractors.
 2. Prepare in a format and with content acceptable to District.
 3. Combine RFI and its attachments into a single electronic file. PDF format is preferred.
- D. Reason for the RFI: Prior to initiation of an RFI, carefully study all Contract Documents to confirm that information sufficient for their interpretation is definitely not included.
 1. Include in each request Contractor's signature attesting to good faith effort to determine from Contract Documents information requiring interpretation.
 - a. Submit RFIs from subcontractors and material suppliers through, be reviewed by and be attached to an RFI prepared, signed and submitted by Contractor.
 - 1) RFIs from subcontractors and material suppliers are to be:
 - (a) Reviewed by Contractor.
 - (b) Corrected and rewritten to clarify as required by Contractor.
 - (c) Placed on the proper form, then signed, and submitted by Contractor.
 - (d) RFIs submitted directly by subcontractors or material suppliers will be returned unanswered to the Contractor.
 - 2) RFIs submitted directly by subcontractors or material suppliers will be returned unanswered to the Contractor.
 - b. Review all subcontractor- and supplier-initiated RFIs and take actions to resolve issues of coordination, sequencing and layout of the Work.
 - 1) RFIs submitted to request clarification of issues related to means, methods, techniques and sequences of construction or for establishing trade jurisdictions and scopes of subcontracts will be returned without response.
 - (a) Such issues are solely the Contractor's responsibility.
 - 2) Contractor is responsible for delays resulting from the necessity to resubmit an RFI due to insufficient or incorrect information presented in the RFI.
 2. Unacceptable Uses for RFIs: Do not use RFIs to request the following::
 - a. Approval of submittals (use procedures specified elsewhere in this section).
 - b. Approval of substitutions (see Section - 01 60 00 - Product Requirements)

- c. Changes that entail change in Contract Time and Contract Sum (comply with provisions of the Conditions of the Contract).
 - d. Different methods of performing work than those indicated in the Contract Drawings and Specifications (comply with provisions of the Conditions of the Contract).
 - 3. Improper RFIs: Requests not prepared in compliance with requirements of this section, and/or missing key information required to render an actionable response. They will be returned without a response, with an explanatory notation.
 - 4. Frivolous RFIs: Requests regarding information that is clearly indicated on, or reasonably inferable from, Contract Documents, with no additional input required to clarify the question. They will be returned without a response, with an explanatory notation.
 - a. The District reserves the right to assess the Contractor for the costs (on time-and-materials basis) incurred by the Architect, and any of its consultants, due to processing of such RFIs.
- E. Content: Include identifiers necessary for tracking the status of each RFI, and information necessary to provide an actionable response.
 - 1. Official Project name and number, and any additional required identifiers established in Contract Documents.
 - 2. District's, Architect's, and Contractor's names.
 - 3. Discrete and consecutive RFI number, and descriptive subject/title.
 - 4. Issue date, and requested reply date.
 - 5. Reference to particular Contract Document(s) requiring additional information/interpretation. Identify pertinent drawing and detail number and/or specification section number, title, and paragraph(s).
 - 6. Annotations: Field dimensions and/or description of conditions which have engendered the request.
 - a. Inability to determine from the Contract Documents the exact material, process, or system to be installed;
 - b. Or when the elements of construction are required to occupy the same space (interference);
 - c. Or when an item of Work is described differently at more than one place in the Contract Documents.
 - 7. Contractor's suggested resolution: A written and/or a graphic solution, to scale, is required in cases where clarification of coordination issues is involved, for example; routing, clearances, and/or specific locations of work shown diagrammatically in Contract Documents. If applicable, state the likely impact of the suggested resolution on Contract Time or the Contract Sum.
 - a. In all cases, furnish all information required for the Architect to analyze and/or understand the circumstances causing the RFI and prepare a clarification or direction as to proceed for RFIs issued to request clarification of issues related to:
 - 1) Means, methods, techniques and sequences of construction, for example
 - 2) Pipe and duct routing, clearances;
 - 3) Specific locations of Work shown diagrammatically;

- 4) Apparent interferences and similar items.
 - 5) If information included with this type RFI by the Contractor is insufficient, the RFI will be returned unanswered.
- F. Attachments: Include sketches, coordination drawings, descriptions, photos, submittals, and other information necessary to substantiate the reason for the request.
- G. RFI Log: Prepare and maintain a tabular log of RFIs for the duration of the project.
1. Indicate current status of every RFI. Update log promptly and on a regular basis.
 2. Note dates of when each request is made, and when a response is received.
 3. Highlight items requiring priority or expedited response.
 4. Highlight items for which a timely response has not been received to date.
 5. Identify and include improper or frivolous RFIs.
- H. Review Time: Architect will respond and return RFIs to Contractor within seven calendar days of receipt. For the purpose of establishing the start of the mandated response period, RFIs received after 12:00 noon will be considered as having been received on the following regular working day.
1. Response period may be shortened or lengthened for specific items, subject to mutual agreement, and recorded in a timely manner in progress meeting minutes.
- I. Responses: Content of answered RFIs will not constitute in any manner a directive or authorization to perform extra work or delay the project. If in Contractor's belief it is likely to lead to a change to Contract Sum or Contract Time, promptly issue a notice to this effect, and follow up with an appropriate Change Order request to District.
1. Response may include a request for additional information, in which case the original RFI will be deemed as having been answered, and an amended one is to be issued forthwith. Identify the amended RFI with an R suffix to the original number.
 2. Do not extend applicability of a response to specific item to encompass other similar conditions, unless specifically so noted in the response.
 3. Upon receipt of a response, promptly review and distribute it to all affected parties, and update the RFI Log.
 4. Notify Architect within seven calendar days if an additional or corrected response is required by submitting an amended version of the original RFI, identified as specified above.

3.10 SUBMITTAL SCHEDULE

- A. Submit to Architect for review a schedule for submittals in tabular format.
1. Submit at the same time as the preliminary schedule.
 - a. Submit initial Submittals Schedule within 14 days of date of Notice of Award of construction.
 - b. After review and return by Architect, resubmit Submittals Schedule within 10 days and thereafter submit updated Submittals Schedules at each Construction Progress Meeting.
 - c. Submit one copy each to Owner and Architect.
 2. Coordinate with Contractor's construction schedule and schedule of values.

3. Format schedule to allow tracking of status of submittals throughout duration of construction.
 - a. Prepare schedules in Gantt format using software at Contractor's option, providing clear indication of sequencing and scheduling of Work, for determination of "critical path" of construction progress.
 - 1) Submittals shall be connected to the related construction element by a graphically indicated critical path on the same page.
 - 2) Present schedules using opaque reproductions on substantial paper, with sheet size a multiple of 8-1/2 by 11 inches and large enough to clearly read characters.
4. Arrange information to include scheduled date for initial submittal, specification number and title, submittal category (for review or for information), description of item of work covered, and role and name of subcontractor.
5. Account for time required for preparation, review, manufacturing, fabrication and delivery when establishing submittal delivery and review deadline dates.

3.11 SUBMITTALS FOR REVIEW

- A. When the following are specified in individual sections, submit them for review:
 1. Product data.
 2. Shop drawings.
 3. Samples for selection.
 4. Samples for verification.
- B. Submit to Architect for review for the limited purpose of checking for compliance with information given and the design concept expressed in Contract Documents.
- C. Samples will be reviewed for aesthetic, color, or finish selection.
- D. After review, provide copies and distribute in accordance with SUBMITTAL PROCEDURES article below and for record documents purposes described in Section 01 78 00 - Closeout Submittals.

3.12 SUBMITTALS FOR INFORMATION

- A. When the following are specified in individual sections, submit them for information:
 1. Design data.
 2. Certificates.
 3. Test reports.
 4. Inspection reports.
 5. Manufacturer's instructions.
 6. Manufacturer's field reports.
 7. Other types indicated.
- B. Submit for Architect's knowledge as contract administrator or for District.

3.13 SUBMITTALS FOR PROJECT CLOSEOUT

- A. Submit Correction Punch List for Substantial Completion.
- B. Submit Final Correction Punch List for Substantial Completion.
- C. When the following are specified in individual sections, submit them at project closeout in compliance with requirements of Section 01 78 00 - Closeout Submittals:
 - 1. Project record documents.
 - 2. Operation and maintenance data.
 - a. Include operation and maintenance data submittals in Submittals Schedule specified above.
 - b. Provide space for review action stamps and, if required by governing authorities having jurisdiction, license seal of design Professional, if applicable.
 - 3. Warranties.
 - 4. Bonds.
 - 5. Other types as indicated.
- D. Submit for District's benefit during and after project completion.

3.14 NUMBER OF COPIES OF SUBMITTALS

- A. Electronic Documents: Submit one electronic copy in PDF format with renderable text; an electronically-marked up file will be returned. Create PDFs at native size and right-side up; illegible files will be rejected.
- B. Small Size Sheets, Not Larger Than 11 by 17 inch: Submit one copy; the Contractor shall make his own copies from original returned by the Architect after making his own file copy.
- C. Extra Copies at Project Closeout: See Section 01 78 00.
- D. Samples: Submit the number specified in individual specification sections; one of which will be retained by Architect.
 - 1. After review, produce duplicates.
 - 2. Retained samples will not be returned to Contractor unless specifically so stated.
 - 3. Quantity:
 - a. Submit minimum of four (4) samples of each of color, texture and pattern.
 - b. Submit one item only of actual assembly or product.
 - c. Unless otherwise noted, full-size and complete samples will be returned and may be incorporated into field mock-ups and the Work.

3.15 SUBMITTAL PROCEDURES

- A. General Requirements:
 - 1. Use a separate transmittal for each item.
 - 2. Submit separate packages of submittals for review and submittals for information, when included in the same specification section.
 - 3. Transmit using approved form.

4. Sequentially identify each item. For revised submittals use original number and a sequential numerical suffix.
5. Identify: Project; Contractor; subcontractor or supplier; pertinent drawing and detail number; and specification section number and article/paragraph, as appropriate on each copy.
 - a. For example:
 - 1) 09 21 16-1 - First submittal for Section 09 21 16 - Gypsum Board Assemblies.
 - 2) 09 21 16-2 - Second submittal for Section 09 21 16 - Gypsum Board Assemblies.
 - b. Use same number for resubmittals as original submittal, followed by a letter indicating sequential resubmittal. For example:
 - 1) 09 21 16-2A - Resubmission of second submittal for Section 09 21 16 - Gypsum Board Assemblies.
 - 2) 09 21 16-2B - Second resubmission of second submittal for Section 09 21 16 - Gypsum Board Assemblies.
6. Apply Contractor's stamp, signed or initialed certifying that review, approval, verification of products required, field dimensions, adjacent construction work, and coordination of information is in accordance with the requirements of the work and Contract Documents.
 - a. Submittals from sources other than the Contractor, or without Contractor's stamp will not be acknowledged, reviewed, or returned.
 - b. Field measurements have been determined and verified.
 - c. Conformance with requirements of Contract Drawings and Specifications is confirmed.
 - d. Catalog numbers and similar data are correct.
 - e. Work being performed by various subcontractors and trades is coordinated.
 - f. Field construction criteria have been verified, including confirmation that information submitted has been coordinated with the work being performed by others for District and actual site conditions.
 - g. All deviations from requirements of Drawings and Specifications have been identified and noted.
7. Deliver each submittal on date noted in submittal schedule, unless an earlier date has been agreed to by all affected parties, and is of the benefit to the project.
 - a. Send submittals in electronic format via email to Architect.
 - b. Upload submittals in electronic form to Electronic Document Submittal Service website.
8. Schedule submittals to expedite the Project, and coordinate submission of related items.
 - a. For each submittal for review, allow 15 days excluding delivery time to and from the Contractor.
 - b. For sequential reviews involving Architect's consultants, District, or another affected party, allow an additional 7 days.
9. Identify variations from Contract Documents and product or system limitations that may be detrimental to successful performance of the completed work.
 - a. Changes in the Work shall not be authorized by submittals review actions.

- b. No review action, implicit or explicit, shall be interpreted to authorized changes in the Work.
 - c. Changes shall only be authorized by separate written Contract Change Order or Construction Change Directive, in accordance with the Conditions of the Contract and Section 01 20 00 - Price and Payment Procedures.
- 10. Provide space for Contractor and Architect review stamps.
- 11. When revised for resubmission, identify all changes made since previous submission.
- 12. Distribute reviewed submittals. Instruct parties to promptly report inability to comply with requirements.
- 13. Incomplete submittals will not be reviewed, unless they are partial submittals for distinct portion(s) of the work, and have received prior approval for their use.
- 14. Submittals not requested will be recognized, but will be returned without comment,
- B. Product Data Procedures:
 - 1. Submit only information required by individual specification sections.
 - 2. Collect required information into a single submittal.
 - 3. Submit concurrently with related shop drawing submittal.
 - 4. Do not submit (Material) Safety Data Sheets for materials or products.
- C. Shop Drawing Procedures:
 - 1. Prepare accurate, drawn-to-scale, original shop drawing documentation by interpreting Contract Documents and coordinating related work.
 - 2. Use of reproductions of Contract Documents in digital data form to create shop drawings is only permitted as defined in Division 01 and individual product sections.
 - 3. Coordination: Show all field dimensions and relationships to adjacent or critical features of Work.
 - 4. Generic, non-project-specific information submitted as shop drawings do not meet the requirements for shop drawings.
- D. Samples Procedures:
 - 1. Transmit related items together as single package.
 - 2. Samples will be reviewed for aesthetic, color, or finish selection.
 - 3. Identify each item to allow review for applicability in relation to shop drawings showing installation locations.
 - 4. Color Selection Samples: Architect will review and select colors for Project only after all colors are received, so that colors may be properly coordinated.
 - 5. Copies: Submit actual samples. Photographic or printed reproductions will not be accepted.
 - 6. Review of Field Samples: Review by Architect of field samples will be made for the following example products, as applicable, if not otherwise required and if requested by Contractor.
 - a. Concrete wall finishes and detailing (edges, corners and reveals).
 - b. Concrete paving colors and textures.

- c. Gypsum board textures and finishes.
- d. Field-applied paint colors and finishes.

3.16 SUBMITTAL REVIEW

- A. Submittals for Review: Architect will review each submittal, and approve, or take other appropriate action.
- B. Submittals for Information: Architect will acknowledge receipt and review. See below for actions to be taken.
- C. Architect's actions will be reflected by marking each returned submittal using virtual stamp on electronic submittals.
 - 1. Notations may be made directly on submitted items and/or listed on appended Submittal Review cover sheet.
- D. Architect's and consultants' actions on items submitted for review:
 - 1. Authorizing purchasing, fabrication, delivery, and installation:
 - a. "Approved", or language with same legal meaning.
 - b. "Approved as Noted, Resubmission not required", or language with same legal meaning.
 - 1) At Contractor's option, submit corrected item, with review notations acknowledged and incorporated.
 - c. "Approved as Noted, Resubmit for Record", or language with same legal meaning.
 - 1) Resubmit corrected item, with review notations acknowledged and incorporated. Resubmit separately, or as part of project record documents.
 - 2) Non-responsive resubmittals may be rejected.
 - 2. Not Authorizing fabrication, delivery, and installation:
 - a. "Revise and Resubmit".
 - 1) Resubmit revised item, with review notations acknowledged and incorporated.
 - 2) Non-responsive resubmittals may be rejected.
 - b. "Rejected".
 - 1) Submit item complying with requirements of Contract Documents.
- E. Architect's and consultants' actions on items submitted for information:
 - 1. Items for which no action was taken:
 - a. "Received" - to notify the Contractor that the submittal has been received for record only.
 - 2. Items for which action was taken:
 - a. "Reviewed" - no further action is required from Contractor.

END OF SECTION

**SECTION 01 30 00.01
REQUEST FOR INTERPRETATION**

RFI NUMBER: _____ **DATE:** _____

PROJECT NAME: INTERIM HOUSING PROJECT NO.: 21056.00

TO: TBP/ARCHITECTURE

. 4611 Teller Avenue, Newport Beach, CA 92660

Attention: _____

Contractor: _____

Address: _____

BRIEF SUMMARY OF RFI: _____

Drawing No. _____ Detail No. _____

Specification Section _____ Title _____

. Page _____ Paragraph _____

DETAILS OF THIS RFI: _____

SUGGESTED SOLUTION: _____

Response required by: _____ (min. 3 full days) Submitted By: _____

. Organization: _____

RESPONSE: _____

Attachments: _____

Response By: _____ Date: _____

Organization: _____

Copies: __ File __ District __ Structural __ Mechanical __ Plumbing __ Electrical
__ Civil __ Landscape __ other consultants

END OF RFI

SECTION 01 35 50
REQUESTS FOR ELECTRONIC FILES

PART 1 - GENERAL

1.01 SECTION INCLUDES

- A. Requirements to request electronic construction document files from Architect.
- B. Hold Harmless Agreement form.

1.02 RELATED SECTIONS

- A. Section 01 30 00 - Administrative Requirements: Shop Drawings, Product Data and Samples.
- B. Section 01 70 00 - Execution and Closeout Requirements.
- C. Divisions 31 through 33 - Site Work.

1.03 REQUIREMENTS

- A. Electronic files have legal ramifications as information therein can be modified.
- B. In order to receive this electronic information, the following Hold Harmless Agreement form must be executed in its entirety, including signature by a company officer.
- C. Costs for processing and handling electronic files, however limited, will be \$250.00

PART 2 - PRODUCTS - (NOT APPLICABLE TO THIS SECTION.)

PART 3 - EXECUTION

3.01 ELECTRONIC FILE TRANSFER PROCEDURE

- A. Submit a check in the amount of \$250.00 along with a list of the requested sheet numbers and an acknowledged copy of this waiver to the office of the Architect, tBP/Architecture, 4611 Teller Avenue, Newport Beach, CA 92660.
- B. In order to expedite the transfer, upon receipt of a PDF copy of this acknowledgement, the requested CAD/Revit/BIM files will be sent in the form of a compact disc, DVD, or thumb drive to the recipient, as requested, by UPS, similar delivery service, or other method of electronic transfer after payment is received.
- C. It is expressly understood that any transfer is done as a courtesy and can be revoked at any time by the Architect.

Agreement is on next page

HOLD HARMLESS AGREEMENT

ARCHITECT'S PROJECT: INTERIM HOUSING

ARCHITECT'S PROJECT NUMBER: 21056.00

We, _____, understand that we may be receiving electronic media containing design information, not necessarily intended for construction. We agree to hold tBP/Architecture harmless for any defects in this data. We agree that it shall be our responsibility to reconcile this electronic data with the paper plans, and that only the paper plans shall be regarded as legal documents for the referenced project.

Further, the Contractor acknowledges that the Architect's reports, drawings, specifications, field data, field notes, laboratory test data, calculations, estimates and other similar documents are instruments of professional service, not products. In accepting and utilizing any drawings or other data on any form of electronic media generated and provided by the Design Professionals, the Parties listed above covenant and agree that all such drawings and data are instruments of service of the Design Professionals, who shall be deemed the author of the drawings and data, and shall retain all common law, statutory law and other rights, including copyrights.

The Parties agree that in accepting and utilizing any drawings and other data, that the Design Professionals waive all responsibility for any subsequent use of these data, the accuracy of dimensions, and the interpretation of information contained herein.

The Parties further agree not to use these drawings and data, in whole or in part, for any purpose or project other than the project which is the subject of this Agreement. The Parties further agree to waive all claims against the Design Professionals resulting in any way from any unauthorized changes of the drawings and data or any other use other than for the project which is the subject of this Agreement.

The Contractor shall indemnify, defend and hold harmless the Design Professionals and its subconsultants and their officers, agents, employees from any claims, damages, losses, liabilities or expenses (including attorneys' fees) arising out of use of such documents without Consultant's prior written authorization.

Under no circumstances shall transfer of the drawings and other data be deemed a sale by the Design Professionals, and the Design Professionals make no warranties, either express or implied of the merchantability and fitness of the data for any particular purpose.

Acknowledged by:

Signature of Company Officer Print or Type Name Date

Company Name

Street Address City, State, Zip Code

E-mail Address

END OF SECTION

SECTION 01 35 53
SECURITY PROCEDURES

PART 1 GENERAL

1.01 SECTION INCLUDES

- A. Security measures including formal security program, entry control, personnel identification, guard service, and miscellaneous restrictions.

1.02 RELATED REQUIREMENTS

- A. Section 01 10 00 - Summary: use of premises and occupancy.
- B. Section 01 50 00 - Temporary Facilities and Controls: Temporary lighting.

1.03 SECURITY PROGRAM

- A. Protect Work, existing premises and District's operations from theft, vandalism, and unauthorized entry.
- B. Initiate program in coordination with District's existing security system at project mobilization.
- C. Maintain program throughout construction period until District acceptance precludes the need for Contractor security.

1.04 ENTRY CONTROL

- A. Restrict entrance of persons and vehicles into Project site and existing facilities.
- B. Allow entrance only to authorized persons with proper identification.
- C. Maintain log of workers and visitors, make available to District on request.
- D. District will control entrance of persons and vehicles related to District's operations.
- E. Contractor shall control entrance of persons and vehicles related to District's operations.
- F. Coordinate access of District's personnel to site in coordination with District's security forces.

1.05 PERSONNEL IDENTIFICATION

- A. Shall be worn by Contractor's superintendent and all sub contractors
- B. Provide identification badge to each person authorized to enter premises.
- C. Badge To Include: Personal photograph, name, assigned number, expiration date and employer.
- D. Maintain a list of accredited persons, submit copy to District on request.
- E. Special badges shall be issued to construction personnel when term of construction exceeds six months.
- F. Require return of badges at expiration of their employment on the Work.

1.06 GUARD SERVICE

- A. Employ uniformed guard service to provide watch persons at site during all non-working hours.

- B. The phone number for security is _____.
- C. All personnel must obey and act immediately upon any request by security.
- D. In an emergency, from inside the facility, dial _____. Outside the facility, dial 911.

1.07 RESTRICTIONS

- A. Do not allow cameras on site or photographs taken except by written approval of District.

PART 2 PRODUCTS - NOT USED

PART 3 EXECUTION - NOT USED

END OF SECTION

SECTION 01 40 00
QUALITY REQUIREMENTS

PART 1 GENERAL

1.01 SECTION INCLUDES

- A. Contractor Quality assurance submittals.
- B. Quality assurance.
- C. Testing and inspection agencies and services.
- D. Contractor's construction-related professional design services.
- E. Control of installation.
- F. Tolerances.
- G. Manufacturers' field services.
- H. Defect Assessment.

1.02 RELATED REQUIREMENTS

- A. Section 01 30 00 - Administrative Requirements: Submittal procedures.
- B. Section 01 41 00 - Regulatory Requirements: Compliance with applicable codes, ordinances and standards.
- C. Section 01 42 19 - Reference Standards.
- D. Section 01 45 33 - Code-Required Special Inspections: Testing laboratory services and inspections required by Division of the State Architect (DSA), during the course of construction.
- E. Section 01 60 00 - Product Requirements: Requirements for material and product quality.
 - 1. Product options, substitutions, transportation and handling requirements, storage and protection requirements, and system completeness requirements.

1.03 REFERENCE STANDARDS

- A. IAS AC89 - Accreditation Criteria for Testing Laboratories.

1.04 DEFINITIONS

- A. Contractor's Quality Control Plan: Contractor's management plan for executing the Contract for Construction.

1.05 CONTRACTOR'S CONSTRUCTION-RELATED PROFESSIONAL DESIGN SERVICES

- A. Coordination: Contractor's professional design services are subject to requirements of project's Conditions for Construction Contract.
- B. Provide such engineering design services as may be necessary to plan and safely conduct certain construction operations, pertaining to, but not limited to the following:
 - 1. Temporary sheeting, shoring, or supports.
 - 2. Temporary scaffolding.

3. Temporary bracing.
4. Temporary falsework for support of spanning or arched structures.
5. Temporary stairs or steps required for construction access only.
6. Temporary hoist(s) and rigging.
7. Investigation of soil conditions to support construction equipment.

1.06 SUBMITTALS

- A. See Section 01 30 00 - Administrative Requirements, for submittal procedures.
- B. Designer's Qualification Statement: Submit for Architect's knowledge as contract administrator, or for District's information.
 1. Include information for each individual professional responsible for producing, or supervising production of, design-related professional services provided by Contractor.
 - a. Full name.
 - b. Professional licensure information.
 - c. Statement addressing extent and depth of experience specifically relevant to design of items assigned to Contractor.
- C. Quality Control Submittals Schedule
 1. Schedule Format: Include quality control submittals on Submittals Schedule specified in accordance with General Conditions
 2. Schedule Content: List all tests, inspections and reports specified to be submitted, indicating submittal number, submittal type (field test, field inspection, fabrication inspection, etcetera), scheduled date of quality control activity and date report should be made.
- D. Design Data: Submit for Architect's knowledge as contract administrator for the limited purpose of assessing compliance with information given and the design concept expressed in the Contract Documents, or for District's information.
 1. Include calculations that have been used to demonstrate compliance to performance and regulatory criteria provided, and to determine design solutions.
 2. Include required product data and shop drawings.
 3. Include a statement or certification attesting that design data complies with criteria indicated, such as building codes, loads, functional, and similar engineering requirements.
 4. Include signature and seal of design professional responsible for allocated design services on calculations and drawings.
- E. Test Reports: After each test/inspection, promptly submit two copies of report to Architect and to Contractor.
 1. Include:
 - a. Date issued.
 - b. Project title and number.
 - c. Name of inspector.
 - d. Date and time of sampling or inspection.

- e. Identification of product and specifications section.
 - f. Location in the Project.
 - g. Type of test/inspection.
 - h. Date of test/inspection.
 - i. Results of test/inspection.
 - j. Compliance with Contract Documents.
 - k. When requested by Architect, provide interpretation of results.
2. Test report submittals are for Architect's knowledge as contract administrator for the limited purpose of assessing compliance with information given and the design concept expressed in the Contract Documents, or for District's information.
- F. Certificates: When specified in individual specification sections, submit certification by the manufacturer and Contractor or installation/application subcontractor to Architect, in quantities specified for Product Data.
1. Indicate material or product complies with or exceeds specified requirements. Submit supporting reference data, affidavits, and certifications as appropriate.
 2. Certificates may be recent or previous test results on material or product, but must be acceptable to Architect.
- G. Manufacturer's Instructions: When specified in individual specification sections, submit printed instructions for delivery, storage, assembly, installation, start-up, adjusting, and finishing, for the District's information. Indicate special procedures, perimeter conditions requiring special attention, and special environmental criteria required for application or installation.
- H. Manufacturer's Field Reports: Submit reports for Architect's benefit as contract administrator or for District.
1. Submit report in duplicate within 30 days of observation to Architect for information.
 2. Submit for information for the limited purpose of assessing compliance with information given and the design concept expressed in the Contract Documents.
- I. Erection Drawings: Submit drawings for Architect's benefit as contract administrator or for District.
1. Submit for information for the limited purpose of assessing compliance with information given and the design concept expressed in the Contract Documents.
 2. Data indicating inappropriate or unacceptable Work may be subject to action by Architect or District.

1.07 QUALITY ASSURANCE

- A. Testing Agency Qualifications:
1. Prior to start of work, submit agency name, address, and telephone number, and names of full time registered Engineer and responsible officer.
 2. Submit copy of report of laboratory facilities inspection made by NIST Construction Materials Reference Laboratory during most recent inspection, with memorandum of remedies of any deficiencies reported by the inspection.

3. Qualification Statement: Provide documentation showing testing laboratory is approved by Division of the State Architect.
 4. Qualification Statement: Provide documentation showing testing laboratory is accredited under IAS AC89.
- B. Designer Qualifications: Where professional engineering design services and design data submittals are specifically required of Contractor by Contract Documents, provide services of a Professional Engineer experienced in design of this type of work and licensed in California.
- C. Contractor's Quality Control (CQC) Plan:
1. Prior to start of work, submit a comprehensive plan describing how contract deliverables will be produced. Tailor CQC plan to specific requirements of the project. Include the following information:
 - a. Management Structure: Identify personnel responsible for quality. Include a chart showing lines of authority.
 - 1) Include qualifications (in resume form), duties, responsibilities of each person assigned to CQC function.
 - b. Management Approach: Define, describe, and include in the plan specific methodologies used in executing the work.
 - 1) Management and control of documents and records relating to quality.
 - 2) Communications.
 - 3) Coordination procedures.
 - 4) Resource management.
 - 5) Process control.
 - 6) Inspection and testing procedures and scheduling.
 - 7) Control of noncomplying work.
 - 8) Tracking deficiencies from identification, through acceptable corrective action, and verification.
 - 9) Control of testing and measuring equipment.
 - 10) Project materials certification.
 - 11) Managerial continuity and flexibility.
 - c. District will not make a separate payment for providing and maintaining a Quality Control Plan. Include associated costs in Bid price.
 - d. Acceptance of the plan is required prior to start of construction activities not including mobilization work. District's acceptance of the plan will be conditional and predicated on continuing satisfactory adherence to the plan. District reserves the right to require Contractor to make changes to the plan and operations, including removal of personnel, as necessary, to obtain specified quality of work results.
- D. Quality-Control Personnel Qualifications. Engage a person with requisite training and experience to implement and manage quality assurance (QA) and quality control (QC) for the project.

1.08 REFERENCES AND STANDARDS - SEE SECTION 01 42 19

1.09 REGULATORY REQUIREMENTS FOR TESTING AND INSPECTION

- A. Inspections, testing and approvals as required by authorities having jurisdiction. Refer to Section 01 41 00 - Regulatory Requirements and Section 01 45 33 - Code-Required Special Inspections.
- B. Standards and Code Compliance and Manufacturer's Instructions and Recommendations: Unless more stringent requirements are indicated or specified, comply with manufacturer's instructions and recommendations, reference standards and building code research report requirements in preparing, fabricating, erecting, installing, applying, connecting and finishing Work.
- C. Deviations from Standards and Code Compliance and Manufacturer's Instructions and Recommendations: Document and explain all deviations from reference standards and building code research report requirements and manufacturer's product installation instructions and recommendations, including acknowledgement by the manufacturer that such deviations are acceptable and appropriate for the Project.

1.10 TESTING AND INSPECTION AGENCIES AND SERVICES

- A. District will employ and pay for services of an independent testing agency approved by DSA to perform specified testing.
- B. As indicated in individual specification sections, District or Contractor shall employ and pay for services of an independent testing agency to perform other specified testing.
- C. Employment of agency in no way relieves Contractor of obligation to perform Work in accordance with requirements of Contract Documents.
- D. Contractor Employed Agency:
 - 1. Laboratory Qualifications: Accredited by IAS according to IAS AC89.
 - 2. Laboratory: Authorized to operate in California.
 - 3. Laboratory Staff: Maintain a full time registered Engineer on staff to review services.
 - 4. Testing Equipment: Calibrated at reasonable intervals either by NIST or using an NIST established Measurement Assurance Program, under a laboratory measurement quality assurance program.

PART 2 PRODUCTS - NOT USED

PART 3 EXECUTION

3.01 CONTRACTOR'S QUALITY ASSURANCE

- A. Quality Requirements: Work shall be accomplished in accordance with quality requirements of the Drawings and Specifications, including, by reference, all Codes, laws, rules, regulations and standards. When no quality basis is prescribed, the quality shall be in accordance with the best accepted practices of the construction industry for the locale of the Project, for projects of this type.

- B. Quality Control Personnel: Contractor shall employ and assign knowledgeable and skilled personnel as necessary to perform quality control functions to ensure that the Work is provided as required.

3.02 CONTROL OF INSTALLATION

- A. Quality of Products: Unless otherwise indicated or specified, all products shall be new, free of defects and fit for the intended use.
- B. Monitor quality control over suppliers, manufacturers, products, services, site conditions, and workmanship, to produce work of specified quality.
- C. Comply with manufacturers' instructions, including each step in sequence.
- D. Should manufacturers' instructions conflict with Contract Documents, request clarification from Architect before proceeding.
- E. Comply with specified standards as minimum quality for the work except where more stringent tolerances, codes, or specified requirements indicate higher standards or more precise workmanship.
- F. Have work performed by persons qualified to produce required and specified quality.
- G. Verify that field measurements are as indicated on shop drawings or as instructed by the manufacturer.
- H. Secure products in place with positive anchorage devices designed and sized to withstand stresses, vibration, physical distortion, and disfigurement.
- I. Quality of Installation: All Work shall be produced plumb, level, square and true, or true to indicated angle, and with proper alignment and relationship between the various elements.
- J. Protection of Existing and Completed Work: Take all measures necessary to preserve and protect existing and completed Work free from damage, deterioration, soiling and staining, until Acceptance by the District.
- K. Verification of Quality: Work shall be subject to verification of quality by District, or Architect in accordance with provisions of the General Conditions of the Contract.
 - 1. Contractor shall cooperate by making Work available for inspection by District, Architect or their designated representatives.
 - 2. Such verification may include mill, plant, shop, or field inspection as required.
 - 3. Provide access to all parts of the Work, including plants where materials or equipment are manufactured or fabricated.
 - 4. Provide all information and assistance as required, including that by and from subcontractors, installers, fabricators, materials suppliers and manufacturers, for verification of quality by District, or Architect.
 - 5. Contract modifications, if any, resulting from such verification activities shall be governed by applicable provisions in the General Conditions.

3.03 TOLERANCES

- A. Monitor fabrication and installation tolerance control of products to produce acceptable Work. Do not permit tolerances to accumulate.

- B. Comply with manufacturers' tolerances. Should manufacturers' tolerances conflict with Contract Documents, request clarification from Architect before proceeding.
- C. Adjust products to appropriate dimensions; position before securing products in place.

3.04 TESTING AND INSPECTION

- A. See individual specification sections for testing required.
- B. Testing Agency Duties:
 - 1. Test samples of mixes submitted by Contractor.
 - 2. Provide qualified personnel at site. Cooperate with Architect and Contractor in performance of services.
 - 3. Perform specified sampling and testing of products in accordance with specified standards.
 - 4. Ascertain compliance of materials and mixes with requirements of Contract Documents.
 - 5. Promptly notify Architect and Contractor of observed irregularities or non-compliance of Work or products.
 - 6. Perform additional tests and inspections required by Architect.
 - 7. Submit reports of all tests/inspections specified.
- C. Limits on Testing/Inspection Agency Authority:
 - 1. Agency may not release, revoke, alter, or enlarge on requirements of Contract Documents.
 - 2. Agency may not approve or accept any portion of the Work.
 - 3. Agency may not assume any duties of Contractor.
 - 4. Agency has no authority to stop the Work.
- D. Contractor Responsibilities:
 - 1. Deliver to agency at designated location, adequate samples of materials proposed to be used that require testing, along with proposed mix designs.
 - 2. Cooperate with laboratory personnel, and provide access to the Work and to manufacturers' facilities.
 - 3. Provide incidental labor and facilities:
 - a. To provide access to Work to be tested/inspected.
 - b. To obtain and handle samples at the site or at source of Products to be tested/inspected.
 - c. To facilitate tests/inspections.
 - d. To provide storage and curing of test samples.
 - 4. Notify Architect and laboratory 24 hours prior to expected time for operations requiring testing/inspection services.
 - 5. Employ services of an independent qualified testing laboratory and pay for additional samples, tests, and inspections required by Contractor beyond specified requirements.
 - 6. Arrange with District's agency and pay for additional samples, tests, and inspections required by Contractor beyond specified requirements.

- 7. Inspections and Tests by Authorities Having Jurisdiction:
 - a. Contractor shall cause all tests and inspections to be made for Work under this Contract, as required by Building Departments, Department of Public Works, Fire Department, Health Department and similar agencies having jurisdiction.
 - b. Excepted as specifically noted, scheduling, conducting and paying for such inspections shall be solely the Contractor's responsibility.
- 8. Inspections and Tests by Serving Utilities:
 - a. Contractor shall cause all tests and inspections required by serving utilities to be made for Work under this Contract.
 - b. Scheduling, conducting and paying for such inspections shall be solely the Contractor's responsibility.
- E. Re-testing required because of non-compliance with specified requirements shall be performed by the same agency on instructions by Architect.
- F. Re-testing required because of non-compliance with specified requirements shall be paid for by Contractor.

3.05 MANUFACTURERS' FIELD SERVICES

- A. When specified in individual specification sections, require material or product suppliers or manufacturers to provide qualified staff personnel to observe site conditions, conditions of surfaces and installation, quality of workmanship, start-up of equipment, test, adjust, and balance equipment as applicable, and to initiate instructions when necessary.
- B. Submit qualifications of observer to Architect 30 days in advance of required observations.
 - 1. Observer subject to approval of Architect.
 - 2. Observer subject to approval of District.
- C. Report observations and site decisions or instructions given to applicators or installers that are supplemental or contrary to manufacturers' written instructions.

3.06 FIELD QUALITY CONTROL SUBMITTALS

- A. Administration: Make all submittals to the Architect, unless otherwise directed.
- B. Submittal Identification: Identify each submittal by Specification Section number followed by a number indicating sequential submittal for that Section. Coordinate submittal numbers with submittals specified in Section 01 30 00 - Administrative Requirements.
 - 1. Resubmittals shall use same number as original submittal, followed by a letter indicating sequential resubmittal.

03 30 00 - 1	First submittal for Section 03 30 00 - Cast in Place Concrete.
03 30 00 - 2	Second submittal for Section 03 30 00 - Cast in Place Concrete.
03 30 00 - 2A	Resubmittal of second submittal for Section 03 30 00 - Cast in Place Concrete.
03 30 00 - 2B	Second resubmittal of second submittal for Section 03 30 00 - Cast in Place Concrete.

- C. Project Identification: Title each submittal with Project name, submittal date and Architect's Project number.
- D. Copies: Provide PDF copies electronically transmitted or submit 6 copies, minimum, of reports of quality control reports on dry-process xerographic copies only.
- E. Contractor's Review:
 - 1. Submittals shall be made in accordance with requirements specified herein and in individual Sections.
 - 2. Indicate clearly on each submittal the specified or referenced values for each quality control activity and the values obtained.
 - 3. Note clearly and sign each submittal certifying that reported quality control activity "Conforms" or "Does Not Conform".
- F. Changes and Deviations:
 - 1. Identify all deviations from requirements of Drawings and Specifications.
 - 2. Changes in the Work shall not be authorized by submittals review actions.
 - 3. No review action, implicit or explicit, shall be interpreted to authorized changes in the Work.
 - 4. Changes shall only be authorized by separate written Change Order or Construction Change Directive, in accordance with the General Conditions and 01 20 00 - Price and Payment Procedures.
- G. Record Submittals: When record submittals are specified, submit three copies or sets only. Record submittals will not be reviewed but will be retained for historical and maintenance purposes.
- H. Unsolicited Submittals: Unsolicited submittals will be returned unreviewed.

3.07 ARCHITECT'S REVIEW

- A. General:
 - 1. Submitted Report review by Architect and Architect's consultants shall be only for general conformance with the design concept and requirements based on the information presented.
 - 2. Neither Architect nor Architect's consultants shall verify submitted quality control data.
- B. Contract Requirements:
 - 1. Review by Architect and Architect's consultants shall not relieve the Contractor from compliance with requirements of the Drawings and Specifications.
 - 2. Changes shall only be authorized by separate written Change Order or Construction Change Directive, in accordance with the General Conditions and 01 20 00 - Price and Payment Procedures.
- C. Observations by Architect and Architect's Consultants: Periodic and occasional observations of Work in progress will be made by Architect and Architect's consultants as deemed necessary to review progress of Work and general conformance with design intent.

3.08 DEFECT ASSESSMENT

- A. Replace Work or portions of the Work not conforming to specified requirements, at no change in Contract Sum or Contract Time.
- B. If, in the opinion of Architect, it is not practical to remove and replace the work, Architect will direct an appropriate remedy or adjust payment.
- C. Architect's Acceptance and Rejection of Work: Architect reserves the right to reject all Work not in conformance to the requirements of the Drawings and Specifications.
- D. Acceptance of Non-Conforming Work: Acceptance of non-conforming Work, without specific written acknowledgement and approval of the District, shall not relieve the Contractor of the obligation to correct such Work.
 - 1. Acceptance of structurally related non-conforming work shall be submitted to DSA for review and approval.
- E. Contract Adjustment for Non-conforming Work:
 - 1. Should Architect or District determine that it is not feasible or in District's interest to require non-conforming Work to be repaired or replaced, an equitable reduction in Contract Sum shall be made by agreement between District and Contractor.
 - 2. If equitable amount cannot be agreed upon, a Construction Change Directive will be issued and the amount in dispute resolved in accordance with applicable provisions of the General Conditions.
- F. Non-Responsibility for Non-Conforming Work: Architect and Architect's consultants disclaim any and all responsibility for Work produced not in conformance with the Drawings and Specifications.

END OF SECTION

SECTION 01 41 00
REGULATORY REQUIREMENTS

PART 1 GENERAL

1.01 AUTHORITY AND PRECEDENCE OF CODES, ORDINANCES AND STANDARDS

- A. Authority: All codes, ordinances and standards referenced in the Drawings and Specifications shall have the full force and effect as though printed in their entirety in the Specifications.
- B. Precedence:
 - 1. Where specified requirements differ from the requirements of applicable codes, ordinances and standards, the more stringent requirements take precedence.
 - 2. Where the Drawings or Specifications require or describe products or execution of better quality, higher standard or greater size than required by applicable codes, ordinances and standards, the Drawings and Specifications take precedence so long as such increase is legal.
 - 3. Where no requirements are identified in the Drawings or Specifications, comply with all requirements of applicable codes, ordinances and standards of authorities having jurisdiction.
- C. Applicable Codes, Laws and Ordinances: Refer also to Section 01 10 00 - Summary, regarding permits and licenses.
 - 1. Performance of the Work is be governed by all applicable laws, ordinances, rules and regulations of Federal, State and local governmental agencies and jurisdictions having authority over the Project, including accessibility requirements.
 - 2. Performance of the Work shall be accomplished in conformance with all rules and regulations of public utilities, utility districts and other agencies serving the development.
 - 3. Where such laws, ordinances, rules and regulations require more care or greater time to accomplish Work, or require better quality, higher standards or greater size of products, Work shall be accomplished in conformance to such requirements with no change to the Contract Time and Contract Sum, except where changes in laws, ordinances, rules and regulations occur subsequent to the execution date of the Agreement.
- D. Applicable Building Codes: References on the Drawings or in the Specifications to "code" or "building code" not otherwise identified shall mean the codes specified below, together with all additions, amendments, changes, and interpretations adopted by code authorities of the jurisdiction having authority over the Project.
- E. Performance of the Work shall meet or exceed the minimum regulatory requirements applicable to this project are summarized in this section, as adopted by Division of the State Architect:
 - 1. Part 1, Title 24 CCR - 2019 California Administrative Code.
 - 2. Part 2, Title 24 CCR - 2019 California Building Code (CBC); Volumes 1 and 2.
 - a. Based on ICC (IBC) - ICC International Building Code, 2018.
 - 3. Part 3, Title 24 CCR - 2019 California Electrical Code (CEC, NFPA 70-NEC 2017).

4. Part 4, Title 24 CCR - 2019 California Mechanical Code (CMC).
 - a. Based on IAPMO (UMC) - Uniform Mechanical Code, 2018.
 5. Part 5, Title 24 CCR - 2019 California Plumbing Code (CPC).
 - a. Based on IAPMO (UPC) - Uniform Plumbing Code, 2018.
 6. Part 6, Title 24 CCR - 2019 California Energy Code.
 7. Part 9, Title 24 CCR - 2019 California Fire Code (CFC).
 - a. Based on ICC (IFC) - International Fire Code; 2018.
 8. Part 10, Title 24 CCR - 2019 California Existing Buildings Code.
 - a. Based on ICC (IEBC) - ICC International Existing Buildings Code, 2018.
 9. Part 11, Title 24 CCR - 2019 California Green Building Standards Code (CalGreen).
 10. Part 12, Title 24 CCR - 2019 California Referenced Standards Code.
- F. Erosion and Sedimentation Control Regulations: .
1. California Codes and Regulations; Title 24, California Building Code, Parts 1 & 2.
 2. State of California State Water Resources Control Board Regulations.
 3. EPA (NPDES) - National Pollutant Discharge Elimination System (NPDES), Construction General Permit.

1.02 SUMMARY OF REFERENCE STANDARDS

- A. Regulatory requirements applicable to this project are the following:
- B. California Referenced Standards Code: Chapter 12-7-4 Fire Resistive Standards, for fire rated doors.
- C. National Fire Protection Association (NFPA): (Partial List of Applicable Standards)
 1. Reference CBC for applicable NFPA Standards - 2019 CBC (SFM) Chapter 35.
 2. NFPA 13 - Standard for the Installation of Sprinkler Systems (CA Amended); is current; use 2016, as amended in 2019 CBC Ch.35 Referenced Standards.
 3. NFPA 24 - Standard for the Installation of Private Fire Service Mains and Their Appurtenances is current; use 2016, as amended in 2019 CBC Ch.35 Referenced Standards.
 4. NFPA 241 - Standard for Safeguarding Construction, Alteration, and Demolition Operations; 2019.
- D. 28 CFR 35 - Nondiscrimination on the Basis of Disability in State and Local Government Services; Final Rule; Department of Justice.
- E. 28 CFR 36 - Nondiscrimination by Public Accommodations and in Commercial Facilities; Final Rule; Department of Justice.
- F. 36 CFR 1191 - Americans with Disabilities Act (ADA) Accessibility Guidelines for Buildings and Facilities; Architectural Barriers Act (ABA) Accessibility Guidelines.
- G. ADA Standards - Americans with Disabilities Act (ADA) Standards for Accessible Design.
- H. 29 CFR 1910 - Occupational Safety and Health Standards.

1.03 RELATED REQUIREMENTS

A. Section 01 40 00 - Quality Requirements.

PART 2 PRODUCTS - NOT USED

PART 3 EXECUTION - NOT USED

END OF SECTION

SECTION 01 42 19
REFERENCE STANDARDS

PART 1 GENERAL

1.01 SECTION INCLUDES

- A. Requirements relating to referenced standards.

1.02 QUALITY ASSURANCE

- A. For products or workmanship specified by reference to a document or documents not included in the Project Manual, also referred to as reference standards, comply with requirements of the standard, except when more rigid requirements are specified or are required by applicable codes.
- B. Conform to reference standard of date of issue specified in the individual specification sections, except where a specific date is established by applicable code.
- C. Obtain copies of standards when required by Contract Documents.
- D. Maintain copy at project site during submittals, planning, and progress of the specific work, until Date of Substantial Completion.
- E. Should specified reference standards conflict with Contract Documents, request clarification from the Architect before proceeding.
- F. Neither the contractual relationships, duties, or responsibilities of the parties in Contract nor those of the Architect shall be altered by Contract Documents by mention or inference otherwise in any reference document.

PART 2 CALIFORNIA DEPARTMENT OF GENERAL SERVICES, DIVISION OF THE STATE ARCHITECT

2.01 INTERPRETATION OF REGULATIONS

- A. Document IR A-5 - Acceptance of Products, Materials, and Evaluations Reports; Revised 1-27-17 .
- B. Current listings are on the DGS website:
<http://www.dgs.ca.gov/dsa/Resources/IRManual.aspx>.

PART 3 UNITED STATES GOVERNMENT AND RELATED AGENCIES DOCUMENTS

3.01 CFR -- CODE OF FEDERAL REGULATIONS

- A. ADA Standards - Americans with Disabilities Act (ADA) Standards for Accessible Design.
- B. 16 CFR 260.13 - Guides for the Use of Environmental Marketing Claims; Federal Trade Commission; Recycled Content.
- C. 16 CFR 1201 - Safety Standard for Architectural Glazing Materials.
- D. 28 CFR 36 - Nondiscrimination by Public Accommodations and in Commercial Facilities; Final Rule; Department of Justice.
- E. 29 CFR 1910 - Occupational Safety and Health Standards.

- F. 29 CFR 1910, Subpart D - Walking-Working Surfaces, 1910.21-1910.30.
- G. 29 CFR 1910.23 - Ladders.
- H. 29 CFR 1910.38 - Emergency action plans.
- I. 29 CFR 1910.132-138 - Personal Protective Equipment.
- J. 29 CFR 1910.134 - Respiratory protection.
- K. 29 CFR 1926.62 - Lead.
- L. 29 CFR 1926.1101 - Asbestos.
- M. 36 CFR 1191 - Americans with Disabilities Act (ADA) Accessibility Guidelines for Buildings and Facilities; Architectural Barriers Act (ABA) Accessibility Guidelines.
- N. 39 CFR 111 - U.S. Postal Service Standard 4C.
- O. 40 CFR 59, Subpart D - National Volatile Organic Compound Emission Standards for Architectural Coatings; U.S. Environmental Protection Agency.
- P. 40 CFR 60 - Standards of Performance for New Stationary Sources.
- Q. 40 CFR 273 - Standards For Universal Waste Management.
- R. 40 CFR 280 - Technical Standards and Corrective Action Requirements for Owners and Operators of Underground Storage Tanks.
- S. 40 CFR 761 - Polychlorinated Biphenyls (PCBs) Manufacturing, Processing, Distribution In Commerce, And Use Prohibitions.
- T. 47 CFR 15 - Radio Frequency Devices.
- U. 47 CFR 68 - Connection of Terminal Equipment to the Telephone Network.
- V. 49 CFR 37 - Transportation Services for Individuals with Disabilities (ADA).
- W. 49 CFR 178 - Specifications for Packaging.
- X. 49 CFR 192.285 - Plastic Pipe: Qualifying Persons to Make Joints.

3.02 CPSC -- CONSUMER PRODUCTS SAFETY COMMISSION

- A. CPSC Pub. No. 325 - Public Playground Safety Handbook.

3.03 EPA -- ENVIRONMENTAL PROTECTION AGENCY

- A. EPA (NPDES) - National Pollutant Discharge Elimination System (NPDES), Construction General Permit.
- B. EPA 600/4-90/010 - Compendium of Methods for the Determination of Air Pollutants in Indoor Air.
- C. EPA 600-4-790-20 - Methods for Chemical Analysis of Water and Wastes.
- D. EPA 625/1-86/021 - Design Manual: Municipal Wastewater Disinfection.
- E. EPA 625/R-96/010b - Compendium of Methods for the Determination of Toxic Organic Compounds in Ambient Air.
- F. EPA 712-C-02-190 - Health Effects Test Guidelines OPPTS 870.1100 Acute Oral Toxicity.

3.04 FDA -- FOOD AND DRUG ADMINISTRATION

- A. FDA Food Code - Chapter 6 - Physical Facilities.

3.05 FEMA -- U.S. FEDERAL EMERGENCY MANAGEMENT AGENCY

- A. FEMA (MAPS) - FEMA Map Service Center.
- B. FEMA 412 - Installing Seismic Restraints for Mechanical Equipment.
- C. FEMA 413 - Installing Seismic Restraints for Electrical Equipment.
- D. FEMA 414 - Installing Seismic Restraints for Duct and Pipe.
- E. FEMA E-74 - Reducing the Risks of Nonstructural Earthquake Damage.

3.06 FS -- FEDERAL SPECIFICATIONS AND STANDARDS (GENERAL SERVICES ADMINISTRATION)

- A. FED-STD-595C - Colors Used in Government Procurement (Fan Deck).
- B. FS L-F-001641 - Floor Covering Translucent or Transparent Vinyl Surface with Backing; 1971, and Amendment 2, 1982.
- C. FS L-S-125 - Screening, Insect, Nonmetallic.
- D. FS RR-P-1352 - Partitions, Toilet, Complete; Revision C, 1989.
- E. FS RR-T-650 - Treads, Metallic and Nonmetallic, Skid Resistant.
- F. FS RR-W-365 - Wire Fabric (Insect Screening); 1980, Rev. A (Amended 1986).
- G. FS SS-T-312 - Tile, Floor: Asphalt, Rubber, Vinyl, and Vinyl Composition; Revision B, 1974, and Amendment 1, 1979.
- H. FS TT-B-1325 - Beads (Glass Spheres); Retro-Reflective.
- I. FS TT-P-115 - Paint, Traffic (Highway, White and Yellow); Revision F, 1984.
- J. FS TT-P-1952 - Paint, Traffic and Airfield Marking, Waterborne.
- K. FS W-C-375 - Circuit Breakers, Molded Case; Branch Circuit and Service.
- L. FS W-C-596 - Connector, Electrical, Power, General Specification for.
- M. FS W-S-896 - Switches, Toggle (Toggle and Lock), Flush-mounted (General Specification).
- N. STATE STD 01.01 - Certification Standard Forced Entry and Ballistic Resistance of Structural Systems; Physical Security Division, Office of Physical Security Programs, Bureau of Diplomatic Security, United States Department of State.
- O. UFC 4-010-01 - DoD Minimum Antiterrorism Standards for Buildings.
- P. USPS Handbook AS-503 - Standard Design Criteria; United States Postal Service.

3.07 GSA -- U.S. GENERAL SERVICES ADMINISTRATION

- A. GSA PBS-P100 - Facilities Standards for the Public Buildings Service; General Services Administration.

3.08 NIJ -- NATIONAL INSTITUTE OF JUSTICE (DEPT. OF JUSTICE)

- A. NIJ 0108.01 - Standard for Ballistic Resistant Protective Materials.

3.09 PS -- PRODUCT STANDARDS

- A. PS 1 - Structural Plywood.
- B. PS 2 - Performance Standard for Wood-Based Structural-Use Panels.
- C. PS 20 - American Softwood Lumber Standard.

3.10 USDA -- UNITED STATES DEPARTMENT OF AGRICULTURE

- A. USDA TR-55 - Urban Hydrology for Small Watersheds; USDA Natural Resources Conservation Service.

3.11 USGS -- UNITED STATES GEOLOGICAL SURVEY

- A. USGS (FMWQ) - National Field Manual for the Collection of Water-Quality Data; United States Geological Survey.

END OF SECTION

SECTION 01 45 33
CODE-REQUIRED SPECIAL INSPECTIONS

PART 1 GENERAL

1.01 SECTION INCLUDES

- A. Division of the State Architect (DSA) Procedures for construction oversight and inspections required during the course of construction.
- B. Code-required special inspections.
 - 1. Division of the State Architect (DSA) approved testing laboratory services and inspections required during the course of construction.
- C. Testing services incidental to special inspections.
- D. Submittals.
- E. Manufacturers' field services.
- F. Fabricators' field services.

1.02 RELATED REQUIREMENTS

- A. Section 01 30 00 - Administrative Requirements: Submittal procedures.
- B. Section 01 40 00 - Quality Requirements.
- C. Section 01 42 19 - Reference Standards.
- D. Section 01 60 00 - Product Requirements: Requirements for material and product quality.

1.03 DEFINITIONS

- A. Code or Building Code: California Building Code and, more specifically, Chapter 17A - Structural Tests and Special Inspections, of same.
- B. Authority Having Jurisdiction (AHJ): Agency or individual officially empowered to enforce the building, fire and life safety code requirements of the permitting jurisdiction in which the Project is located. AHJ for this Project is Division of the State Architect.
- C. Special Inspection:
 - 1. Special inspections are inspections and testing of materials, installation, fabrication, erection or placement of components and connections mandated by the CBC that also require special expertise to ensure compliance with the approved contract documents and the referenced standards.
 - 2. Special inspections are separate from and independent of tests and inspections conducted by District or Contractor for the purposes of quality assurance and contract administration.

1.04 REFERENCE STANDARDS

- A. ACI 318 - Building Code Requirements for Structural Concrete and Commentary.
- B. ASCE 7 - Minimum Design Loads and Associated Criteria for Buildings and Other Structures.
- C. ASTM A615/A615M - Standard Specification for Deformed and Plain Carbon-Steel Bars for Concrete Reinforcement.

- D. ASTM A706/A706M - Standard Specification for Deformed and Plain Low-Alloy Steel Bars for Concrete Reinforcement.
- E. ASTM C143/C143M - Standard Test Method for Slump of Hydraulic-Cement Concrete.
- F. ASTM C31/C31M - Standard Practice for Making and Curing Concrete Test Specimens in the Field.
- G. ASTM C172/C172M - Standard Practice for Sampling Freshly Mixed Concrete.
- H. ASTM C94/C94M - Standard Specification for Ready-Mixed Concrete.
- I. ASTM D1556/D1556M - Standard Test Method for Density and Unit Weight of Soil in Place by Sand-Cone Method.
- J. ASTM D1557 - Standard Test Methods for Laboratory Compaction Characteristics of Soil Using Modified Effort (56,000 ft-lbf/ft³ (2,700 kN m/m³)).
- K. ASTM D3740 - Standard Practice for Minimum Requirements for Agencies Engaged in the Testing and/or Inspection of Soil and Rock as Used in Engineering Design and Construction.
- L. ASTM E329 - Standard Specification for Agencies Engaged in Construction Inspection, Testing, or Special Inspection.
- M. ASTM E543 - Standard Specification for Agencies Performing Nondestructive Testing.
- N. AWS D1.4/D1.4M - Structural Welding Code - Reinforcing Steel.
- O. TMS 402/602 - Building Code Requirements and Specification for Masonry Structures.

1.05 SUBMITTALS

- A. See Section 01 30 00 - Administrative Requirements, for submittal procedures.
- B. Special Inspection Agency Qualifications: Prior to the start of work, the Special Inspection Agency is required to:
 - 1. Submit agency name, address, and telephone number, names of full time registered Engineer and responsible officer.
 - 2. Submit copy of report of laboratory facilities inspection made by NIST Construction Materials Reference Laboratory during most recent inspection, with memorandum of remedies of any deficiencies reported by the inspection.
 - 3. Submit certification that Special Inspection Agency is acceptable to AHJ.
- C. Testing Agency Qualifications: Prior to the start of work, the Testing Agency is required to:
 - 1. Submit agency name, address, and telephone number, and names of full time registered Engineer and responsible officer.
 - 2. Testing and inspections will be performed by an independent testing laboratory selected and employed by the District and approved by the Division of the State Architect (DSA).
 - a. Qualification of a testing agency or laboratory will be under the jurisdiction of the DSA Structural Safety Section (SSS). Procedural and acceptance criteria are set forth in the California Administrative Code (CBC) Chapter 4.
- D. Manufacturer's Qualification Statement: Manufacturer is required to submit documentation of manufacturing capability and quality control procedures. Include documentation of AHJ approval.

- E. Fabricator's Qualification Statement: Fabricator is required to submit documentation of fabrication facilities and methods as well as quality control procedures.
- F. Distribution List: The Testing Laboratory will make the following distribution of test and inspection reports:
 - 1. District 1
 - 2. Architect 2
 - 3. Structural Engineer 1
 - 4. Contractor 1
 - 5. District's Inspector 1
 - 6. Division of the State Architect 1
 - 7. Construction Manager 1
- G. Each and every test or inspection report shall bear the File Number and Application Number assigned to this project by the DSA.
- H. DSA Form 291: From the engineering manager of the laboratory of record.
- I. Special Inspection Reports: After each special inspection, Special Inspector is required to promptly submit at least two copies of report; one to Architect and one each to the distribution list.
 - 1. Include:
 - a. Date issued.
 - b. Project title and number.
 - c. Name of Special Inspector.
 - d. Date and time of special inspection.
 - e. Identification of product and specifications section.
 - f. Location in the Project.
 - g. Type of special inspection.
 - h. Date of special inspection.
 - i. Results of special inspection.
 - j. Compliance with Contract Documents.
 - 2. Final Special Inspection Report: Document special inspections and correction of discrepancies prior to the start of the work.
 - 3. Comply with DSA IR 17-12, revised 04/23/20.
- J. Fabricator Special Inspection Reports: After each special inspection of fabricated items at the Fabricator's facility, Special Inspector is required to promptly submit at least two copies of report; one to Architect and one each to the distribution list.
 - 1. Include:
 - a. Date issued.
 - b. Project title and number.
 - c. Name of Special Inspector.
 - d. Date and time of special inspection.
 - e. Identification of fabricated item and specification section.

- f. Location in the Project.
 - g. Results of special inspection.
 - h. Verification of fabrication and quality control procedures.
 - i. Compliance with Contract Documents.
 - j. Compliance with referenced standard(s).
- K. Test Reports: After each test or inspection, promptly submit at least two copies of report; one to Architect and one each to the distribution list.
1. Include:
 - a. Date issued.
 - b. Project title and number.
 - c. Name of inspector.
 - d. Date and time of sampling or inspection.
 - e. Identification of product and specifications section.
 - f. Location in the Project.
 - g. Type of test or inspection.
 - h. Date of test or inspection.
 - i. Results of test or inspection.
 - j. Compliance with Contract Documents.
 - k. Test reports shall be signed by a Civil Engineer licensed in the State of California.
 2. Test reports shall include all tests made, regardless of whether such tests indicate that the material is satisfactory or unsatisfactory.
 - a. Samples taken but not tested shall also be reported.
 - b. Records of special sampling operations as required shall also be reported.
 - c. Reports shall show that the material or materials were sampled and tested in accordance with the requirements of the CBC, and with the approved specifications.
 - d. They shall also state definitely whether or not the material or materials tested comply with requirements.
 - e. Test reports shall be issued within 14 days of finding being known, to all parties listed above.
 3. At the completion of the project, Testing Laboratory shall certify in writing and on all required DSA forms, that all work specified or required to be tested and inspected conforms to drawings, specifications and applicable building codes.
 4. Verification of Test Reports:
 - a. The Testing Laboratory of record shall submit to the Division of the State Architect (DSA) a verified report covering all tests which are required to be made by that agency during the progress of the project.
 - 1) Such report shall be furnished each time that work on the project is suspended, covering the tests up to that time, and at the completion of the project.
 - 2) Specific testing requirements as listed on the Structural Test and Inspections (T&I) Form DSA-103 for this project. These tests may include the following forms:

- (a) DSA-201: Soils Compaction.
 - (b) DSA-202: Sieve Analysis.
 - (c) DSA-203: Tension/Bend.
 - (d) DSA-204: Compression.
 - (e) DSA-205: Concrete Masonry Unit.
 - (f) DSA-206: Anchor Load.
 - (g) DSA-207: Masonry Core Shear/Compression.
 - (h) DSA-250: Special Inspection(s).
 - (i) DSA-291: Laboratory Verified Report.
 - (j) DSA-292: Special Inspection(s) Verified Report(s).
 - (k) DSA-293: Geotechnical Verified Report.
- 3) Other Division of the State Architect (DSA) Certification Documents (Reports) as may be required.
- b. DSA Form 292 - Special Inspection Verified Report shall be from all special inspectors contracting directly and individually with the school board.
- L. Certificates: When specified in individual special inspection requirements, Special Inspector shall submit certification by the manufacturer, fabricator, and installation subcontractor to Architect and AHJ, in quantities specified for Product Data.
- 1. Indicate material or product complies with or exceeds specified requirements. Submit supporting reference data, affidavits, and certifications as appropriate.
 - 2. Certificates may be recent or previous test results on material or product, but must be acceptable to Architect and AHJ.
- M. Manufacturer's Field Reports: Submit reports to Architect.
- 1. Submit report in duplicate within 7 days of observation to Architect for information.
 - 2. Submit for information for the limited purpose of assessing compliance with information given and the design concept expressed in Contract Documents.
- N. Fabricator's Field Reports: Submit reports to Architect and AHJ.
- 1. Submit report in duplicate within 30 days of observation to Architect for information.
 - 2. Submit for information for the limited purpose of assessing compliance with information given and the design concept expressed in Contract Documents.

1.06 SPECIAL INSPECTION AGENCY

- A. District will employ services of a Special Inspection Agency to perform inspections and associated testing and sampling in accordance with ASTM E329 and required by the building code.
- B. The Special Inspection Agency may employ and pay for services of an independent testing agency to perform testing and sampling associated with special inspections and required by the building code.
- C. Employment of agency in no way relieves Contractor of obligation to perform work in accordance with requirements of Contract Documents.

1.07 TESTING AND INSPECTION AGENCIES

- A. District is to employ services of an independent inspection and testing agency to perform observation, testing and sampling associated with special inspections including those not required by the building code. CAC
 - 1. Project Inspector and testing lab are employed by the District and approved by:
 - a. A/E of Record.
 - b. Structural Engineer (when applicable).
 - c. DSA.
- B. Employment of agency in no way relieves Contractor of obligation to perform work in accordance with requirements of Contract Documents.

1.08 QUALITY ASSURANCE

- A. Special Inspection Agency Qualifications:
 - 1. Independent firm specializing in performing testing and inspections of the type specified in this section.
- B. Testing Agency Qualifications:
 - 1. Independent firm specializing in performing testing and inspections of the type specified in this section.
 - 2. Testing Agency must possess DSA LEA Program acceptance.
- C. Testing and inspection services which are performed shall be in accordance with requirements of the CBC, and as specified herein. Testing and inspection services shall verify that work meets the requirements of the Construction Documents.
- D. In general, tests and inspections for structural materials shall include all items enumerated on the Structural Tests and Inspections list for this project as prepared and distributed by the Architect.
- E. Copies of Documents at Project Site: Maintain at the project site a copy of each referenced document.

1.09 INSPECTION BY THE DISTRICT

- A. The District shall have the right to reject materials and workmanship which are defective, or to require their correction.
 - 1. Rejected workmanship shall be satisfactorily corrected and rejected materials shall be removed from the premises without charge to the District.
 - 2. If the Contractor does not correct such rejected work within a reasonable time, the District may correct such rejected work and charge the expense to the Contractor.
- B. Should it be considered necessary or advisable by the District at any time before final acceptance of the entire work to make an examination of work already completed by removing or tearing out the completed work; the Contractor shall on request promptly furnish necessary facilities, labor and materials.
 - 1. If such work is found to be defective in any respect due to fault of the Contractor or his subcontractor, he shall defray all expenses of such examinations and of satisfactory reconstruction. .

2. If, however, such work is found to meet the requirements of the Contract, the additional cost of labor and material necessarily involved in the examination and replacement shall be allowed the Contractor.

1.10 DISTRICT'S INSPECTOR

- A. A Project Inspector (IOR) employed by the District and approved by Architect, Structural Engineer and DSA in accordance with the requirements of the California Building Code will be assigned to the work.
 1. Project Inspector duties are specifically defined in CCR Title 24 Part 1, Sec. 4-211(b), 4-219, 4-333(b), 4-336 and 4-342.
- B. The District's Inspector shall at all times have access for the purpose of inspection to all parts of the work and to the shops where the work is in preparation, and the Contractor shall at all times maintain proper facilities and provide safe access for such inspection.
- C. The work of construction in all stages of progress shall be subject to the personal continuous observation of the District's Inspector.
 1. The Contractor shall furnish the Inspector reasonable facilities for obtaining such information as may be necessary to keep him fully informed respecting the progress and manner of the work and the character of the materials.
 2. Inspection of the work shall not relieve the Contractor from any obligation to fulfill this Contract.
 3. Inspector of Record is required to work a normal 40 hour week on this project only. Any overtime required will be at the expense of the Contractor and sub-contractor requiring the inspection.

1.11 PAYMENTS

- A. Costs of initial testing and inspection, except as specifically modified herein, or specified otherwise in technical sections, will be paid for by the District, providing such testing and inspection indicates compliance with Contract Documents. Initial tests and inspections are defined as the first tests and inspections as herein specified.
- B. In the event a test or inspection indicates failure of a material or procedure to meet requirements of Contract Documents, costs for retesting and reinspection will be paid by the District and backcharged to the Contractor.
- C. Additional tests and inspections not herein specified but requested by District or Architect, will be paid for by District, unless results of such tests and inspections are found to be not in compliance with Contract Documents, in which case the District will pay all costs for initial testing as well as retesting and reinspection and backcharge the Contractor.
- D. Costs for additional tests or inspections required because of change in materials being provided or change of source or supply will be paid by District and backcharged to the Contractor.
- E. Costs for tests or inspections which are required to correct deficiencies will be paid by the District and backcharged to the Contractor.
- F. Cost of testing which is required solely for the convenience of Contractor in his scheduling and performance of work will be paid by the District and backcharged to the Contractor.

- G. Overtime costs for testing and inspections performed outside the regular work day hours, including weekends and holidays, will be paid for by the District and backcharged to the Contractor. Such costs include overtime costs for the District's Inspector.
- H. Testing Laboratory shall separate and identify on the invoices, the costs covering all testing and inspections which are to be backcharged to the Contractor as specified above.
- I. Testing Laboratory shall furnish to District a cost estimate breakdown covering initial tests and inspections required by Contract Documents. Estimate shall include number of tests, man-hours required for tests, field and plant inspections, travel time, and costs.

PART 2 PRODUCTS - NOT USED

PART 3 EXECUTION

3.01 SCHEDULE OF SPECIAL INSPECTIONS, GENERAL

- A. Frequency of Special Inspections: Special Inspections are indicated as continuous or periodic.
 - 1. Continuous Special Inspection: Special Inspection Agency is required to be present in the area where the work is being performed and observe the work at all times the work is in progress.
 - 2. Periodic Special Inspection: Special Inspection Agency is required to be present in the area where work is being performed and observe the work part-time or intermittently and at the completion of the work.
- B. Tests and inspections for the following will be required in accordance with the current CBC, unless otherwise specified.

3.02 SPECIAL INSPECTIONS FOR CONCRETE CONSTRUCTION (CHAPTER 17A AND 19A)

- A. Inspection:
 - 1. Job Site Inspection: CBC 1705A.3, 1705A.3.5 (Conc. Preplacement), 1705A.3.6 (Placing Record), and 1910A.
 - 2. Batch Plant or Weighmaster Inspection: CBC 1705A.3.3.
 - a. Waiver of Continuous Batch Plant Inspection:
 - 1) Continuous batch plant inspection may be waived if the concrete plant complies fully with the requirements of CBC 1705A.3.3.1 subject to approval of DSA complying with either of these conditions:
 - (a) The plant must comply fully with the requirements of ASTM C94/C94M, Sections 8 and 9, and has a current certificate from the National Ready Mixed Concrete Association or another agency acceptable to the enforcement agency. The certification shall indicate that the plant has automatic batching and recording capabilities.
 - b. Prior to waiving of batch plant inspection, the testing lab must certify and submit evidence of compliance to the Architect and DSA and obtain agency approval prior to mixing concrete.
 - 1) Qualified technician of the testing laboratory shall check the first batching at the start of the day.

- 2) Licensed weigh-master to positively identify materials as to quantity and certify to each load by a batch ticket.
 - 3) Batch tickets, including material quantities and weights shall accompany the load, shall be transmitted to the Inspector of Record by a truck driver with load identified thereon. The load shall not be placed without a batch ticket identifying the mix. The inspector will keep a daily record of placements, identifying each truck, its load and time of receipt, and approximate location of deposit in the structure and will transmit a copy of the the daily record to the enforcement agency.
- B. Reinforcing Steel, Including: Verify compliance with approved contract documents and ACI 318, Sections 20.2, 25.2 through 25.7, and 26.6.
1. Reinforcing Bars: CBC 1901A.6; 1910A.2.
 2. Tests:
 - a. Tests shall be performed before the delivery of steel to Project site. Steel not meeting specifications shall not be shipped to the Project.
 - b. Testing procedure shall conform to ASTM A615/A615M or .
 - c. Sample at the place of distribution, before shipment:
 - 1) Make one tensile test and one bending test from samples out of 10 tons, or fraction thereof, of each size and kind of reinforcing steel, where taken from bundles as delivered from the mill and properly identified as to heat number.
 - 2) Mill analysis shall accompany report.
 - 3) Where identification number cannot be ascertained, or where random samples are taken, make one series of tests from each 2-1/2 tons, or fraction thereof, of each size and kind of reinforcing steel.
 - 4) Tests on unidentified reinforcing steel will be paid by the District and backcharged to the Contractor.
 - 5) Samples shall include not fewer than 2 pieces, each 18 inches long, of each size and kind of reinforcing steel.
 - d. District's Inspector will inspect all reinforcement for concrete work for size, dimensions, locations and proper placement.
- C. Reinforcing Bar Welding: Verify compliance with AWS D1.4/D1.4M and ACI 318, 26.6.4; continuous.
1. Verify weldability of reinforcing bars other than those complying with ASTM A706/A706M; periodic.
 2. Inspect single-pass fillet welds, maximum 5/16 inch; periodic.
 3. Inspect all other welds; continuous.
 4. Reinforcing Bar Welding Inspection: CBC 1705A.3.1; Table 1705A.3, Item 2; 1903A.8.
- D. Anchors Cast in Concrete: Verify compliance with ACI 318, 17.8.2; periodic.
- E. Anchors Post-Installed in Hardened Concrete: Verify compliance with ACI 318.
1. Comply with CBC Section 1910A.5; Table 1705A.3, items 4a & 4b, ASCE 7, Section 13.4.
 2. Adhesive Anchors: Verify horizontally or upwardly-inclined orientation installations resisting sustained tension loads - Section 17.8.2.4; continuous.
 3. Other Mechanical and Adhesive Anchors: Verify as per Chapter 17.8.2; periodic.

- F. Anchors Installed in Hardened Concrete: Verify compliance with ACI 318; periodic.
- G. Design Mix: Verify plastic concrete complies with the design mix in approved contract documents and with CBC Chapter 19A, ACI 318, Sections 26.4.3, 26.4.4; periodic.
 - 1. Portland Cement Tests: CBC 1705A.3.2, 1910A.1.
 - 2. Concrete Aggregates: CBC 1705A.3.2, 1903A.5.
 - 3. Batch Plant Inspection: CBC 1705A.3.3.
 - 4. Waiver of Continuous Batch Plant Inspection and Tests: CBC 1705A.3.3.1.
 - 5. Admixtures: CBC 1910A.1.
 - 6. Proportions of Concrete: CBC 1904A (Durability) and 1905A (Modifications to ACI 318).
- H. Concrete Sampling Concurrent with Strength Test Sampling: Each time fresh concrete is sampled for strength tests, verify compliance with ASTM C172/C172M, ASTM C31/C31M and ACI 318, Chapter 26.5, 26.12, and record the following, continuous:
 - 1. Slump.
 - 2. Air content.
 - 3. Temperature of concrete.
 - 4. Strength Tests of Concrete: CBC 1905A.1.15; Table 1705A.3 Item 6; ACI 318-14 Sec. 26.12.
- I. Concrete Placement: Verify application techniques comply with approved Contract Documents and ACI 318, Chapter 26.5; continuous.
- J. Specified Curing Temperature and Techniques: Verify compliance with ACI 318, Chapter 26.5.3-26.5.5; continuous.
- K. Concrete Strength in Situ: Verify concrete strength complies with approved Contract Documents, CBC Table 1705A.3, 1905A.1.15, and modified ACI 318, Chapter 26.12.2,1(a).
- L. Formwork Shape, Location and Dimensions: Verify compliance with approved Contract Documents and ACI 318, Chapter 26.11.1.2(b); continuous.
- M. Welding of Reinforcing Bars: Conduct special inspections and verify Special Inspector's qualifications in accordance with requirements of AWS D1.4/D1.4M.
- N. District Inspector (IOR) will do the following:
 - 1. Inspect placing of reinforcing steel and concrete at Project.
 - 2. Obtain weighmaster's certificate and identify mix before accepting each load.
 - 3. Keep daily record of concrete placement, identifying each truck load, time of receipt, and location of concrete in structure.
 - 4. Keep record until completion of Project and make available for inspection by DSA Field Engineer or representative.
 - 5. See also subparagraph on Waiver of Continuous Batch Plant Inspection above.
 - 6. During progress of work, take an additional number of test cylinders as directed by Architect. Conform to CBC 1905A.1.15 (modified ACI 318). Test cylinders need not be made for concrete used in exterior flatwork.
 - a. ACI 318 Section 26.12.2.1 shall be replaced and the Contractor shall comply with the following:

- 1) Samples for strength test of each class of concrete placed each day shall not be taken less than once for each 50 cubic yards (38.3m³) of concrete, or not less than once for each 2,000 square feet (186 m²) of surface area of for slabs or walls.
 - 2) Additional samples for seven day compressive strength tests shall be taken for each class of concrete at the beginning of the concrete work or whenever the mix or aggregate is changed.
7. One set of cylinders shall consist of 4 samples all taken from same batch, one to be tested at age of 7 days and two at 28 days.
 8. Make and store cylinders according to ASTM C31/C31M.
 9. Deliver cylinders to laboratory or store cylinders in a suitable protected environment for pick up by laboratory personnel.
 10. Make slump test of wet concrete according to test for slump of portland cement concrete, ASTM C143/C143M, at least at the same frequency that the cylinders are taken.

3.03 SPECIAL INSPECTIONS FOR MASONRY CONSTRUCTION (CHAPTER 17A AND 21A)

- A. Masonry Structures Subject to Special Inspection:
 1. Masonry construction when required by the quality assurance program of TMS 402/602.
 2. Engineered masonry in structures classified as "low hazard..." and "substantial hazard to human life in the event of failure".
- B. Verify each item below complies with approved Contract Documents and the applicable articles of TMS 402/602.
 1. Materials:

a. Masonry Units	CBC 2103A.1
b. Mortar, Portland Cement	CBC 2103A.2
c. Mortar and Grout Aggregates	CBC 2103A.2; 2103A.3
d. Reinforcing Bars	CBC 2103A.4
 2. Masonry Quality:

a. Portland Cement Tests	CBC 1903A, 1910A.1
b. Mortar and Grout Tests	CBC 2105A.3
c. Masonry Core Tests	CBC 2105A.4
d. Masonry Unit Tests	CBC 2105A.2, 2105A.3, 1705A.4
e. Reinforcing Bar Tests	CBC 1910A.2
 3. Masonry Inspection:

a. Reinforced Masonry	CBC 1705A.4; TMS 602 Tables 3 & 4, level 3.
b. Reinforcing Bar Welding Inspection	CBC 1705A.3.1; Table 1705A.3, Item 2; Table 1705A.3, Item 2; 1903A.8.
 4. Inspections and Approvals:
 - a. Verify compliance with the required inspection provisions of the approved Contract Documents; periodic.
 - b. Verify approval of submittals required by Contract Documents; periodic.

5. Compressive Strength of Masonry: Verify compressive strength of masonry units prior to start of construction unless specifically exempted by code; periodic.
 - a. Comply with CBC 2105A.2 Compressive Strength.
6. Slump Flow and Visual Stability Index (VSI): Verify compliance as self consolidating grout arrives on site; continuous.
7. Joints and Accessories: When masonry construction begins, verify:
 - a. Proportions of site prepared mortar; periodic.
 - b. Construction of mortar joints; periodic.
 - c. Location of reinforcement, connectors, prestressing tendons, anchorages, etc; periodic.
8. Structural Elements, Joints, Anchors, Protection: During masonry construction, verify:
 - a. Size and location of structural elements; periodic.
 - b. Type, size and location of anchors, including anchorage of masonry to structural members, frames or other construction; periodic.
 - c. Size, grade and type of reinforcement, anchor bolts and prestressing tendons and anchorages; periodic.
 - d. Welding of reinforcing bars; continuous.
 - e. Preparation, construction and protection of masonry against hot weather above 90 degrees F and cold weather below 40 degrees F; periodic.
9. Grouting Preparation: Prior to grouting, verify:
 - a. Comply with CBC 2105A.2 Compressive Strength.
 - b. Grout space is clean; periodic.
 - c. Correct placement of reinforcing, connectors, prestressing tendons and anchorages; periodic.
 - d. Correctly proportioned site prepared grouts and prestressing grout for bonded tendons; periodic.
 - e. Correctly constructed mortar joints; periodic.
10. Preparation of Grout Specimens, Mortar Specimens and Prisms: Observe preparation of specimens; periodic.
 - a. Comply with CBC 2105A.2 Compressive Strength.

3.04 SPECIAL INSPECTIONS FOR SITE-BUILT WOOD CONSTRUCTION

- A. Conform to CBC 1705A.5.3 Wood Structural Elements and Assemblies.

3.05 SPECIAL INSPECTIONS FOR SOILS

- A. Materials and Placement: Verify each item below complies with approved construction documents and approved geotechnical report.
 1. Design bearing capacity of material below shallow foundations; periodic.
 2. Design depth of excavations and suitability of material at bottom of excavations; periodic.
 3. Materials, densities, lift thicknesses; placement and compaction of backfill: continuous.
 4. Subgrade, prior to placement of compacted fill verify proper preparation; periodic.

- B. Testing: Classify and test excavated material; periodic.
- C. Excavations, Foundations and Retaining Walls (Chapters 17A, 18A, and 33):
 - 1. Earth Compaction: CBC 1705A.6; Table 1705A.6, continuous; 1804A.6.
 - 2. Verify use of proper materials, densities, and lift thicknesses during placement and compaction of compacted fill: CBC 1705A.6.1; Table 1705A.6, periodic; 1804A.6.
- D. The Geotechnical Engineer of record or a Geotechnical Engineer selected by the District will provide continuous inspection of fill and will field test fill and earth backfill as placed and compacted, and inspect excavations and subgrade before concrete is placed and provide periodic inspection of open excavations, embankments, and other cuts or vertical surfaces of earth.
 - 1. The Geotechnical Engineer will submit a Verified Report indicating observations, tested fills, and opinion the fills were placed in accordance with the project specifications.
- E. Contractor shall remove unsatisfactory material, re-roll, adjust moisture, place new material, or in the case of excavations, provide proper protective measures, perform other operations necessary, as directed by the Geotechnical Engineer whose decisions and directions will be considered final.
- F. Soils Test and Inspection Procedure:
 - 1. Allow sufficient time for testing, and evaluation of results before material is needed. The Geotechnical Engineer shall be sole and final judge of suitability of all materials.
 - 2. Laboratory compaction tests to be used will be in accordance with ASTM D1557.
 - 3. Field density tests will be made in accordance with ASTM D1556/D1556M.
 - 4. Number of tests will be determined by Geotechnical Engineer. Materials in question may not be used pending test results.
 - 5. Excavation and embankment inspection procedure. Geotechnical Engineer will visually or otherwise examine such areas for bearing values, cleanliness and suitability.
 - 6. Earthwork Test Reports: In order to avoid misinterpretations by the reviewing agencies, all retest results shall be reported on the same sheet, immediately following the previous failure test to which it is related. Retests shall be clearly noted as such.

3.06 SPECIAL INSPECTIONS FOR SEISMIC RESISTANCE

- A. Inspection: Comply with CBC 1705A.12.
- B. Testing: Comply with CBC 1705A.13.
- C. Structural Wood:
 - 1. Field gluing; continuous.
 - 2. Nailing, bolting, anchoring and other fastening of components within the seismic force-resisting system; periodic.
- D. Designated Seismic System Verification: Verify label, anchorage or mounting complies with certificate of compliance provided by manufacturer or fabricator.
- E. Structural Testing for Seismic Resistance:
 - 1. Concrete reinforcement: Comply with ACI 318, Section 20.2.2.5 and 21.1.52.

- a. Materials Obtain mill certificates demonstrating compliance with ASTM A615/A615M; periodic.
 - b. Welding: Perform chemical tests complying with ACI 318, Section 26.6.4 to determine weldability; periodic.
2. Non-Structural Components:
- a. General Design Requirements: Obtain manufacturer certification of compliance with requirements of ASCE 7, Section 13.2.1; periodic.
 - b. Designated Seismic Force-Resisting Non-Structural System Components: Obtain manufacturer certification of compliance with ASCE 7, Section 13.2.2; periodic.
- F. Structural Observations for Seismic Resistance: Visually observe structural system for general compliance with the approved Contract Documents; periodic.

3.07 SPECIAL INSPECTIONS FOR WIND RESISTANCE

- A. Structural Wood:
- 1. Field gluing of components in the main wind force-resisting system; continuous.
 - 2. Nailing, bolting, anchoring and other fastening of components within the main wind force-resisting system; periodic.
- B. Structural Observations for Wind Resistance: Visually observe structural system for general compliance with the approved Contract Documents; periodic.

3.08 STRUCTURAL OBSERVATIONS FOR STRUCTURES

- A. Provide Observations: For structure where one or more of the following conditions exist:
- 1. Such observation is required by the registered design professional responsible for the structural design.
 - 2. Such observation is specifically required by AHJ.

3.09 SPECIAL ARCHITECTURAL INSPECTIONS

- A. Signs and/or identification devices:
- 1. Prior to issuance of a final Certificate of Occupancy, Enforcing Agency shall verify installation of signs for information content, appearance, location and Braille per CBC 11B-703.1.1.2.
 - a. Inspection shall include, but not limited to:
 - 1) Braille dots and cells are properly spaced and the size proportion and type raised characters are in compliance with these regulations.
 - 2) Tactile exit signage per CBC 1013.4 and 11B-216.4.1 Exit doors.
 - 3) Tactile floor designation signs in stairways per CBC 1023.9 Stairway identification signs.
 - 4) Tactile special egress control device signs per CBC 1010.1.9.7 Delayed Egress Locks, item 5.1.
 - 5) Elevator car control identification per CBC 11B-407.4.6-8 Elevator car controls.
 - 6) Sanitary facilities signage per CBC 11B-216.8 Toilet rooms and bathing rooms; and 11B-703.7.2.6 Toilet and bathing facilities geometric symbols.
- B. Waterproofing Verification:

1. The District's Inspector will check surfaces and approve before application of membrane materials and verify that substrate surfaces are in satisfactory condition to receive membrane materials and furnish continuous inspection during application of membrane.
2. Check minimum specified thickness of membrane waterproofing. For fluid-applied membrane check thickness every 100 square feet during application with a mil-thickness gage especially manufactured for the purpose.

3.10 SPECIAL INSPECTION AGENCY DUTIES AND RESPONSIBILITIES

- A. Special Inspection Agency shall:
 1. Verify samples submitted by Contractor comply with the referenced standards and the approved Contract Documents.
 2. Provide qualified personnel at site. Cooperate with Architect and Contractor in performance of services.
 3. Perform specified sampling and testing of products in accordance with specified reference standards.
 4. Ascertain compliance of materials and products with requirements of Contract Documents.
 5. Promptly notify Architect, SEOR, IOR, DSA, District and Contractor of observed irregularities or non-conformance of work or products.
 6. Perform additional tests and inspections required by Architect.
 7. Submit reports of all tests or inspections specified.
- B. Limits on Special Inspection Agency Authority:
 1. Agency may not release, revoke, alter, or enlarge on requirements of Contract Documents.
 2. Agency may not approve or accept any portion of the work.
 3. Agency may not assume any duties of Contractor.
 4. Agency has no authority to stop the work.
- C. Re-testing required because of non-compliance with specified requirements shall be performed by the same agency on instructions by Architect.
- D. Re-testing required because of non-compliance with specified requirements shall be paid for by Contractor.

3.11 TESTING AGENCY DUTIES AND RESPONSIBILITIES

- A. Testing Agency Duties:
 1. Test samples submitted by Contractor.
 2. Provide qualified personnel at site. Cooperate with Architect and Contractor in performance of services.
 3. Perform specified sampling and testing of products in accordance with specified standards.
 4. Ascertain compliance of materials and mixes with requirements of Contract Documents.

5. Promptly notify Architect and Contractor of observed irregularities or non-compliance of work or products.
 6. Perform additional tests and inspections required by Architect.
 7. Attend preconstruction meetings and progress meetings.
 8. Submit reports of all tests or inspections specified.
- B. Limits on Testing or Inspection Agency Authority:
1. Agency may not release, revoke, alter, or enlarge on requirements of Contract Documents.
 2. Agency may not approve or accept any portion of the work.
 3. Agency may not assume any duties of Contractor.
 4. Agency has no authority to stop the work.
- C. Immediately upon determination of a test failure, the Laboratory shall telephone the results to the Architect. On the same day, Laboratory shall send test results by email to the Architect and to all relevant responsible parties of the project team, and District's Inspector
- D. On instructions by Architect, perform re-testing required because of non-compliance with specified requirements, using the same agency.
- E. Contractor will pay for re-testing required because of non-compliance with specified requirements.
- F. At the completion of the project, Testing Laboratory shall certify in writing and on all required DSA forms, that all work specified or required to be tested and inspected conforms to drawings, specifications and applicable building codes.
1. See DSA Procedure PR 13-01.
- G. Duties of the Laboratory of Record related to the use of form DSA 152 are as follows:
1. Meet with the Project Inspector, design professionals, and contractor as needed to mutually communicate and understand the testing and inspection program and the methods of communication appropriate for the project.
 2. Obtain a copy of the DSA approved construction documents from the design professional in general responsible charge prior to the commencement of construction
 3. Obtain a copy of the DSA approved Statement of Structural Tests and Special Inspections (form DSA 103) from the design professional in general responsible charge prior to the commencement of construction.
 4. Report all project related activities to the Project Inspector. The Project Inspector is responsible for monitoring the work of the Laboratory of Record and Special Inspectors to ensure the testing and special inspection program is satisfactorily completed
 5. Provide material testing as identified in the DSA approved construction documents.
 6. Submit test reports to the Project Inspector on the day the tests were performed for any tests performed on-site
 7. Submit material test reports in a timely manner such that construction is not delayed and not to exceed 14 days from the date the material tests were performed. Test reports are to be submitted to DSA, the Architect, structural engineer, Project Inspector and school district.

- a. As a convenience, and if agreed upon by involved parties, the test reports may be submitted electronically as identified in Section 4 of this procedure.
 - 8. Immediately submit reports of material tests not conforming to the requirements of the DSA approved construction documents. These reports shall be submitted to the DSA, Architect, structural engineer, Project Inspector and school district.
 - 9. The Engineering Manager shall submit an interim Laboratory of Record Verified Report (form DSA 291) and the Geotechnical Engineer shall submit an interim Geotechnical Verified Report (form DSA 293) to DSA, the project inspector, school district and the Design Professional in General Responsible Charge.
 - a. The reports are required to be submitted upon any of the following events occurring:
 - 1) Within 14 days of the completion of the material testing/special inspection program.
 - 2) Work on the project is suspended for a period of more than one month.
 - 3) The services of the laboratory of record are terminated for any reason prior to completion of the project.
 - 4) The DSA requests a Verified Report. (See interim verified reports below. This is a "DSA request.")
 - 10. The Engineering Manager shall submit an interim verified report (form DSA 291) and the Geotechnical Engineer shall submit form DSA 293 to DSA and a copy to the project inspector for each of the applicable sections of the form DSA 152, prior to the project inspector signing off that section of the project inspection card, if that section required material testing. The sections are:
 - a. Initial Site Work
 - b. Foundation Prep
 - c. Vertical Framing
 - d. Horizontal Framing
 - e. Appurtenances
 - f. Finish Site Work
 - g. Other Work
 - h. Final
- H. Duties of Special Inspectors, employed by the Laboratory of Record, related to the use of form DSA 152 are as follows:
- 1. Meet with the Project Inspector, design professionals, and contractor as needed to mutually communicate and understand the testing and inspection program and the methods of communication appropriate for the project.
 - 2. Report all project related activities to the Project Inspector. The Project Inspector is responsible for monitoring the work of the Laboratory of Record and Special Inspectors to ensure the testing and special inspection program is satisfactorily completed.
 - 3. Perform work under the supervision of the Engineering Manager for the Laboratory of Record
 - 4. Perform inspections in conformance with the DSA approved construction documents, applicable codes and code reference standards

5. Prepare detailed daily inspection reports outlining the work inspected and provide the Project Inspector a copy of the reports on the same day the inspections were performed.
 6. Prepare detailed daily inspection reports outlining the work inspected and provide the Project Inspector a copy of the reports on the same day the inspections were performed.
 7. Immediately submit reports of materials or work not conforming to the requirements of the DSA approved construction documents. These reports shall be submitted to the DSA, Architect, structural engineer, Project Inspector and school district.
 8. Submit daily special inspection reports in a timely manner such that construction is not delayed and not to exceed 14 days from the date the special inspections were performed. The reports are to be submitted to the Architect, structural engineer, Project Inspector and school district.
 9. Submit Verified Report forms DSA 292 to the DSA, Project Inspector, district and design professional in responsible charge.
 10. The reports are required to be submitted upon any of the following events occurring:
 11. Within 14 days of the completion of the special inspection work.
 12. Work on the project is suspended for a period of more than one month.
 13. The services of the special inspector are terminated for any reason prior to completion of the project.
 14. The DSA requests a Verified Report. (See interim verified reports below. This is a "DSA request")
 15. Submit an interim Verified Report (form DSA 292) to the DSA and a copy to the Project Inspector for each of the applicable sections of the form DSA 152, prior to the Project Inspector signing off that section of the project inspection card, if that section required special inspections. The sections are:
 - a. Initial Site Work
 - b. Foundation
 - c. Vertical Framing
 - d. Horizontal Framing
 - e. Appurtenances
 - f. Non-Building Site Structures
 - g. Finish Site Work
 - h. Other Work
 - i. Final
 16. The Verified Reports shall be sent electronically to the DSA.
- I. Duties of Special Inspectors, not employed by the Laboratory of Record, related to the use of form DSA 152 are as follows:
1. Meet with the project inspector, Laboratory of Record, the design professionals, and the contractors as needed to mutually communicate and understand the testing and inspection program, and the methods of communication appropriate for the project.

2. Report all project related activities to the project inspector. The project inspector is responsible for monitoring the work of the Laboratory of Record and special inspectors to ensure the testing and special inspection program is satisfactorily completed.
3. Perform work under the direction of the design professional in general responsible charge, as defined in Section 4-335(f)1B of the California Administrative Code (Title 24, Part 1).
4. Perform inspections in conformance with the DSA approved construction documents, applicable codes and code reference standards.
5. Prepare detailed daily inspection reports outlining the work inspected and provide the project inspector a copy of the reports on the same day the inspections were performed.
6. Immediately submit reports of materials or work not conforming to the requirements of the DSA approved construction documents. These reports shall be submitted to DSA, the Architect, structural engineer, project inspector and the school district.
7. Submit daily special inspection reports in a timely manner such that construction is not delayed and not to exceed 14 days from the date the special inspections were performed. The reports are to be submitted to DSA, the Architect, structural engineer, project inspector and the school district.
8. Submit Special Inspection Verified Report forms DSA 292 to DSA, the project inspector, the school district and the Design Professional in General Responsible Charge.
 - a. The reports are required to be submitted upon any of the following events occurring:
 - 1) Within 14 days of the completion of the special inspection work.
 - 2) Work on the project is suspended for a period of more than one month.
 - 3) The services of the special inspector are terminated for any reason prior to completion of the project.
 - 4) DSA requests a verified report. (See interim verified reports below. This is a "DSA request.")
9. Submit an interim Special Inspection Verified Report (form DSA 292) to DSA and a copy to the project inspector for each of the applicable sections of the form DSA 152, prior to the project inspector signing off that section of the project inspection card, if that section required special inspections.
 - a. The sections are:
 - 1) Initial Site Work
 - 2) Foundation Prep
 - 3) Vertical Framing
 - 4) Horizontal Framing
 - 5) Appurtenances
 - 6) Finish Site Work
 - 7) Other Work
 - 8) Final

3.12 CONTRACTOR DUTIES AND RESPONSIBILITIES

A. DSA Requirements:

1. Each Multi-Prime Contractor or Subcontractor shall comply with DSA Construction Oversight Procedure PR 13-01. California Code of Regulations (CCR), Title 24, Part 1, CCR, Chapter 4, Article 1 (Sections 4-211 through 4-220) and Group1, Articles 5 and 6 (Sections 4-331 through 4-344) which provide regulations governing the construction process for projects under the jurisdiction of the Division of the State Architect (DSA).
 - a. Assist the Project Inspector (IOR) and complete and fill out the following forms during the course of construction.
 - 1) Form-102-IC: Construction Start Notice/ Inspection Card Request: Verify Project Inspector has an active form issued by DSA.
 - 2) Form-151: Project Inspector Notifications: Contractor to notify IOR and assist.
 - 3) Form-152: Project Inspection Card: See below.
 - 4) Form-154: Notice of Deviations/ Resolution of Deviations: Contractor to verify all deviations are reviewed, corrected, and accepted by the design professional, and filed with DSA through the Project Inspector (IOR).
 - (a) When the Project Inspector identifies deviations from the DSA approved construction documents the inspector must verbally notify the contractor. If the deviations are not corrected within a reasonable time frame, the inspector is required to promptly issue a written notice of deviation to the contractor, with a copy sent to the design professional in general responsible charge and the DSA.
 - (b) When the noticed deviations are corrected, the inspector is required to promptly issue a written notice of resolution to the contractor, with a copy sent to the design professional in general responsible charge and the DSA.
 - (c) Deviations include both construction deviations and material deficiencies.
 - (d) The written notice of deviations shall be made using form DSA 154.
 - (e) The notice of resolution of deviations shall be made using the original form DSA 154 that reported the deviations.
 - 5) Form-156: Commencement/Completion of Work Notification
 - 6) Form-6.C: Verified Report – Contractor: From each contractor having a contract with the school board.
2. Duties of Contractor related to the use of form DSA 152 are as follows:
 - a. The Contractor shall carefully study the DSA approved documents and shall plan a schedule of operations well ahead of time.
 - b. If at any time it is discovered that work is being done which is not in accordance with the DSA approved construction documents, the Contractor shall correct the work immediately.
 - c. Verify that forms DSA 152 are issued for the project prior to the commencement of construction.
 - d. Meet with the design team, the Laboratory of Record and the Project Inspector to mutually communicate and understand the testing and inspection program and the methods of communication appropriate for the project.
 - e. Notify the Project Inspector, in writing, of the commencement of construction of each and every aspect of the work at least 48 hours in advance by submitting form DSA 156 (or other agreed upon written documents) to the Project Inspector.

- f. Notify the Project Inspector of the completion of construction of each and every aspect of the work by submitting form DSA 156 (or other agreed upon written documents) to the Project Inspector.
- g. Consider the relationship of the signed off blocks and sections of the form DSA 152 and the commencement of subsequent work. Until the Project Inspector has signed off applicable blocks and sections of the form DSA 152, the Contractor may be prohibited from proceeding with subsequent construction activities that cover up the unapproved work. Any subsequent construction activities, that cover up the unapproved work, will be subject to a "Stop Work Order" from the DSA or the district and are subject to removal and remediation if found to be in non-compliance with the DSA approved construction documents.
- h. Submit the final verified report. All prime contractors are required to submit final Contractor Verified Reports (form DSA 6-C) to DSA and the project inspector.
 - 1) The reports are required to be submitted upon any of the following events occurring:
 - (a) The project is substantially complete. DSA considers the project to be complete when the construction is sufficiently complete in accordance with the DSA approved construction documents so that the owner can occupy or utilize the project.
 - (b) Work on the project is suspended for a period of more than one month.
 - (c) The services of the contractor are terminated for any reason prior to the completion of the project.
 - (d) DSA requests a verified report.

B. Contractor Responsibilities, General:

- 1. Deliver to agency at designated location, adequate samples of materials for special inspections that require material verification.
- 2. Availability of Samples
 - a. Contractor shall make materials required for testing available to Laboratory and assist in acquiring these materials as directed by the District's Inspector. The samples shall be taken under the immediate direction and supervision of the Testing Laboratory or District's Inspector.
 - b. If work which is required to be tested or inspected is covered up without prior notice or approval, such work may be uncovered at the discretion of Architect at no additional cost to the District. Refer to paragraph "Payments" herein.
 - c. Unless otherwise specified, Contractor shall notify Testing Laboratory a minimum of 10 working days in advance of all required tests, and a minimum of 2 working days in advance of all required inspections. All extra expenses resulting from a failure to notify the Laboratory will be paid by the District and backcharged to the Contractor.
 - d. Contractor shall give sufficient advance notice to Testing Laboratory in the event of cancellation or time extension of a scheduled test or inspection. Charges due to insufficient advance, notice of cancellations, or time extension will be paid for by the District and backcharged to the Contractor.
- 3. Cooperate with agency and laboratory personnel; provide access to approved documents at project site, to the work, to manufacturers' facilities, and to fabricators' facilities.

4. Provide incidental labor and facilities:
 - a. To provide access to work to be tested or inspected.
 - b. To obtain and handle samples at the site or at source of Products to be tested or inspected.
 - c. To facilitate tests or inspections.
 - d. To provide storage and curing of test samples.
 5. Notify Architect and laboratory 24 hours prior to expected time for operations requiring testing or inspection services.
 6. Arrange with District's agency and pay for additional samples, tests, and inspections required by Contractor beyond specified requirements.
 7. The Contractor shall notify the District's Inspector a minimum of 5 working days in advance of the manufacture of material to be supplied by him under the Contract Documents, which must be by terms of the Contract be tested, in order that the District may arrange for the testing of such material at the source of supply.
 8. Material shipped by the Contractor from the source of supply before having satisfactorily passed such testing and inspection or before the receipt of notice from said Inspector that such testing and inspection will not be required, shall not be incorporated in the Project.
 9. The District will select and pay testing laboratory costs for all tests and inspections, but may be reimbursed by the Contractor for such costs under the Contract conditions. Any direct payments by the Contractor to the testing laboratory on this project is prohibited.
- C. Contractor shall submit a written statement of responsibility to comply with CBC section 1704A.4.
1. Each contractor responsible for the construction of a main wind- or seismic-force-resisting system, designated seismic system or a wind- or seismic-resisting component listed in the statement of special inspections shall submit a written statement of responsibility to the building official and the owner prior to the commencement of work on the system or component. The contractor's statement of responsibility shall contain the following:
 - a. Acknowledgment of awareness of the special requirements contained in the statement of special inspections;
 - b. Acknowledgment that control will be exercised to obtain conformance with the construction documents approved by the building official;
 - c. Procedures for exercising control within the contractor's organization, the method and frequency of reporting and the distribution of the reports; and
 - d. Identification and qualifications of the person(s) exercising such control and their position(s) in the organization.
- D. Contractor Responsibilities, Seismic Force-Resisting System, Designated Seismic System, and Seismic Force-Resisting Component: Submit written statement of responsibility for each item listed in the Statement of Special Inspections to AHJ and District prior to starting work. Statement of responsibility shall acknowledge awareness of special construction requirements and other requirements listed.

- E. Contractor Responsibilities, Wind Force-Resisting System and Wind Force-Resisting Component: Submit written statement of responsibility for each item listed in the Statement of Special Inspections to AHJ and District prior to starting work. Statement of responsibility shall acknowledge awareness of special construction requirements and other requirements listed.
- F. Unless otherwise directed, materials not conforming to the requirements of Contract Documents shall be promptly removed from the Project site.

3.13 MANUFACTURERS' AND FABRICATORS' FIELD SERVICES

- A. When specified in individual specification sections, require material suppliers, assembly fabricators, or product manufacturers to provide qualified staff personnel to observe site conditions, conditions of surfaces and installation, quality of workmanship, start-up of equipment, to test, adjust, and balance equipment as applicable, and to initiate instructions when necessary.
- B. Submit qualifications of observer to Architect 30 days in advance of required observations.
 - 1. Observer subject to approval of Architect.
 - 2. Observer subject to approval of District.
- C. Report observations and site decisions or instructions given to applicators or installers that are supplemental or contrary to manufacturers' written instructions.

END OF SECTION

SECTION 01 50 00
TEMPORARY FACILITIES AND CONTROLS

PART 1 GENERAL

1.01 SECTION INCLUDES

- A. Temporary sanitary facilities.
- B. Temporary Controls: enclosures and fencing.
- C. Waste removal facilities and services.
- D. Project identification sign.

1.02 RELATED REQUIREMENTS

- A. Section 01 35 53 - Security Procedures

1.03 REFERENCE STANDARDS

1.04 TEMPORARY UTILITIES

- A. Provide and pay for all electrical power, lighting, and water required for construction purposes.
- B. Existing facilities may not be used.
- C. Use trigger-operated nozzles for water hoses, to avoid waste of water.

1.05 TEMPORARY SANITARY FACILITIES

- A. Provide and maintain required facilities and enclosures. Provide at time of project mobilization.
 - 1. Provide temporary toilet facilities if maximum number of personnel on project is greater than 10.
 - 2. Submit proposed location of temporary toilet(s) to Construction Manager for approval.
 - a. Place on-site portable toilets away from building air intakes and entryway.
- B. Maintain daily in clean and sanitary condition.

1.06 FENCING

- A. Construction: Contractor's option.
- B. Provide 6 foot high fence around construction site; equip with vehicular and pedestrian gates with locks.

1.07 SECURITY

- A. Coordinate with District's security program.

1.08 CAFETERIA AND FOOD

- A. Construction personnel shall police their own areas. All cups, cans, paper, wrappers, and discarded food must be placed in trash receptacles at end of each break.

- B. Contractor(s) shall submit to Construction Manager proposed location of any break areas and eating areas for approval.

1.09 SMOKING AND TOBACCO

- A. Smoking and vaping is not permitted on property.
- B. No chewing tobacco or spitting of tobacco is permitted.

1.10 VEHICULAR ACCESS AND PARKING

- A. Comply with regulations relating to use of streets and sidewalks, access to emergency facilities, and access for emergency vehicles.
- B. Coordinate access and haul routes with governing authorities and District.
- C. Provide and maintain access to fire hydrants, free of obstructions.
- D. Provide means of removing mud from vehicle wheels before entering streets.
- E. Provide temporary parking areas to accommodate construction personnel. When site space is not adequate, provide additional off-site parking.

1.11 WASTE REMOVAL

- A. See Section 01 74 19 - Construction Waste Management and Disposal, for additional requirements.
- B. Provide waste removal facilities and services as required to maintain the site in clean and orderly condition.
- C. Provide containers with lids. Remove trash from site periodically.
- D. If materials to be recycled or re-used on the project must be stored on-site, provide suitable non-combustible containers; locate containers holding flammable material outside the structure unless otherwise approved by the authorities having jurisdiction.
- E. Open free-fall chutes are not permitted. Terminate closed chutes into appropriate containers with lids.

1.12 PROJECT IDENTIFICATION

- A. Provide project identification sign of design and construction indicated on drawings.
- B. Erect on site at location indicated.
- C. No other signs are allowed without District permission except those required by law.

1.13 REMOVAL OF UTILITIES, FACILITIES, AND CONTROLS

- A. Remove temporary utilities, equipment, facilities, materials, prior to Date of Substantial Completion inspection.
- B. Remove underground installations to a minimum depth of 2 feet. Grade site as indicated.
- C. Clean and repair damage caused by installation or use of temporary work.
- D. Restore existing facilities used during construction to original condition.
- E. Restore new permanent facilities used during construction to specified condition.

PART 2 PRODUCTS - NOT USED

PART 3 EXECUTION - NOT USED

END OF SECTION

SECTION 01 57 23

TEMPORARY STORM WATER POLLUTION CONTROL

PART 1 - GENERAL

- 1.1** The Contractor shall exercise every reasonable precaution to protect channels, storm drains, and bodies of water from pollution.
- A. Conduct and schedule operations to minimize or avoid muddying and silting channels, drains, and waters.
 - B. As required, obtain permits for erosion and water pollution control from the appropriate jurisdictional agency before starting Work.
 - C. Provide any necessary water pollution control devices to prevent, control, and abate water pollution, and implement good housekeeping pollution control measures to reduce the discharge of pollutants from work sites to the maximum extent practicable. These water pollution control devices include drains, gutters, slope protection blankets and retention basins and shall be constructed concurrently with other Work at the earliest practicable time.
 - D. Exercise care in preserving vegetation and protecting property, to avoid disturbing areas beyond the limits of the Work. Promptly repair any damage caused by Contractor operations.
 - E. Comply with the specific requirements based on acreage of disturbed soil.
 - F. Penalties: Failure to comply with this Section may result in significant fines and possible imprisonment. The RWQCB or other prosecuting authority may assess fines of up to \$32,500 per day for each violation. Should the Owner be fined or penalized as a result of the Contractor failing to comply with this Section, the Contractor shall reimburse the Owner for any and all fines, penalties and related costs.
 - G. Notification and Report: If pollution occurs in the work area for any reason or when the Contractor becomes aware of any violation of this Section, correct the problem and immediately notify the Inspector. In addition, submit a written report to the Engineer within seven (7) calendar days describing the incident and the corrective actions taken. If either the Inspector or Engineer is first to observe pollution or a violation, the Contractor shall also explain in the written report why the Work was inadequately monitored.
 - H. The provisions of this Section describe minimum compliance and do not preclude other more stringent stormwater pollution control measures that may be required in the Contract.

1.2 DEFINITIONS

- A. "Construction activity": Operations such as clearing, grading, disturbances to the ground such as stockpiling, or excavation that results in soil disturbances. If construction activity is part of a larger common plan of development, the amount of disturbed soil is the total land area of disturbed soil that results under the common plan.

1.3 LIABILITIES & PENALTIES:

- A. Payment of penalties for non-compliance by CONTRACTOR shall be the sole responsibility of CONTRACTOR.
- B. Compliance with the Clean Water Act pertaining is the sole responsibility of CONTRACTOR. Any fine against OWNER due to non-compliance by CONTRACTOR, OWNER shall recover all costs of the fine by appropriate OWNER Assessment.

PART 2 - EXECUTION

2.1 Construction activity: Comply with the following minimum water quality protection requirements.

- A. Retain eroded sediments and other pollutants on-site and do not allow transportation from the site by sheet flow, swales, area drains, natural drainage, or wind. Control slope and channel erosion by implementing an effective combination of best management practices (BMPs). Such BMPs include scheduling grading during non-rainy seasons, planting and maintaining vegetation on slopes and covering erosion-susceptible slopes.
- B. Protect stockpiles of earth and other construction-related materials from being transported from the site by wind or water.
- C. Properly store and handle fuels, oils, solvents, and other toxic materials to not contaminate the soil or surface waters, enter the groundwater, or be placed where they may enter a live stream, channel, drain, or other water conveyance facility. Protect all approved toxic storage containers from weather. Clean spills immediately and properly dispose of cleanup materials. Spills shall not be washed into live streams, channels, drains, or other water conveyance facilities. IF RAIN OR STORM WATER RUN OFF COMES IN CONTACT WITH POLLUTANTS (SUCH AS SOIL STABILIZERS, PAINT OR FLUID FROM VEHICLES) REPORT TO INSPECTOR IMMEDIATELY. CONTRACTOR WILL BE REQUIRED TO SAMPLE AND REMEDIATE CONTAMINATED WATER.
- D. Do not wash excess or waste concrete into the public way or any drainage system. Retain concrete wastes on-site until they can be appropriately disposed of or recycled.
- E. Deposit trash and construction-related solid wastes in covered receptacles to prevent contamination of rainwater and dispersal by wind.

- F. Do not allow sediments and other materials to be tracked from the site by vehicle traffic. Stabilize construction entrance roadways to inhibit sediments from being deposited onto public ways. Immediately sweep up accidental depositions. Do not allow depositions to be washed away by rain or by any other means.
- G. Contain non-stormwater runoff from equipment or vehicle washing and any other activity at the work site.
- H. At completion of the Work, clear the worksite of debris and restore to a condition at least equal to or better than prior to construction.

PART 3 – MAINTENANCE

- 3.1 To ensure the proper implementation and functioning of control measures, the Contractor shall regularly inspect and maintain the construction site. The Contractor shall identify corrective actions and time needed to address any deficient measures or reinstate any measures that have been discontinued. Inspections of the construction site shall be conducted by the Contractor to identify deficient measures, as follows:
 - 1. Prior to a forecast storm;
 - 2. At 24-hour intervals during extended precipitation events;
 - 3. After all precipitation, which causes runoff capable of carrying sediment from the construction site; and;
 - 4. Routinely, at a minimum of once every week during the rainy season (October 1st – April 30th) and once every month during non-rainy season (May 1st – September 30th).
- 3.2 All temporary and/or permanent post-construction control measures shall be maintained and regularly inspected by the Contractor after all improvements are in place and accepted by the Owner. Temporary and/or permanent post-construction landscaping maintenance shall include but not limited to, watering, seeding, hydro-seeding, matting, slope stabilization, re-vegetation, and any other maintenance control measures recommended by the Owner to insure proper erosion control and plant growth.

END OF SECTION

SECTION 01 58 13
TEMPORARY PROJECT SIGNAGE

PART 1 GENERAL

1.01 SECTION INCLUDES

- A. Project identification sign.
- B. Project informational signs.

1.02 RELATED REQUIREMENTS

- A. Section 01 10 00 - Summary: Responsibility to provide signs.
- B. Section 05 50 00 - Metal Fabrications: Miscellaneous connectors.
- C. Section 06 10 00 - Rough Carpentry: General requirements for structural and non-structural rough carpentry Work.
- D. Section 09 91 13 - Exterior Painting: General requirements for paint products and painting.

1.03 REFERENCE STANDARDS

- A. FHWA (SHS) - Standard Highway Signs and Markings.

1.04 QUALITY ASSURANCE

- A. Design sign and structure to withstand 80 miles/hr wind velocity.
- B. Sign Painter: Experienced as a professional sign painter for minimum three years.
 - 1. Sign painter shall be regularly engaged and specializing in the design, execution, construction and installation of exterior signage of equivalent type, size and complexity as those required for Project.
- C. Finishes, Painting: Adequate to withstand weathering, fading, and chipping for duration of construction.

1.05 SUBMITTALS

- A. See Section 01 30 00 - Administrative Requirements for submittal procedures.
- B. Shop Drawing: Show content, layout, lettering, color, foundation, structure, sizes and grades of members.

PART 2 PRODUCTS

2.01 SIGN MATERIALS

- A. Structure and Framing: New, wood, structurally adequate to support sign panel and suitable for specified finish.
- B. Sign Surfaces: Exterior grade plywood with medium or high density phenolic sheet overlay, minimum 3/4 inch thick, standard large sizes to minimize joints. Provide sheet thickness as required to span across framing members and provide even, smooth surface without waves or buckles.

- C. Rough Hardware: Galvanized steel, as specified in Section 05 50 00 - Metal Fabrications and Section 06 10 00 - Rough Carpentry..
- D. Sign Face Paint and Primers: Exterior quality, primer, two gloss enamel finish coats; sign background of color as selected. Provide paint type as customarily used for sign painting, adequate to resist weathering and fading for the scheduled construction period.
- E. Sign Structure Paint and Primers: Exterior quality, primer, one gloss enamel finish coats; color as selected. Provide paint type as customarily used for sign painting, adequate to resist weathering and fading for the scheduled construction period.
- F. Lettering: Exterior quality paint, colors as selected.

2.02 PROJECT IDENTIFICATION SIGN

- A. Provide painted sign of construction, design, and content shown on Drawings, location designated or agreed to by Architect.
 - 1. Graphic design, text, style of lettering, and colors shall be as directed; assume 4 colors and special graphic for Project title.
- B. Content:
 - 1. Project number, title, logo and name of District as indicated on Contract Documents.
 - 2. Include organizational logos of parties identified on sign.
 - 3. Names and titles of authorities.
 - 4. Names and titles of Architect and Consultants.
 - 5. Name of Prime Contractor and major Subcontractors.
- C. Graphic Design, Colors, Style of Lettering: Designated by Architect.
 - 1. Sign Painting: Sign panels shall be shop painted and field installed.
 - a. Sign painting shall be performed by professional sign painters. Silk screen method is recommended in order to accurately depict graphics.
 - b. Paint back and edges of sign panels for complete weather resistance and finished appearance.
- D. Project Address Signs: Provide Project name and street address signs, minimum of 4 feet wide, to identify Project to facilitate deliveries.
 - 1. Graphic design and colors shall match Project Identification Sign.
 - 2. Text shall be as directed.
- E. Lettering: Standard Alphabet Series C, as specified in FHWA (SHS).

2.03 PROJECT INFORMATIONAL SIGNS

- A. Restrictions: Signs other than Project Identification Sign specified above and Project Informational Signs specified below shall not be displayed without approval of Architect.
- B. Project Informational Signs: Informational signs, necessary for conduct of construction activities or required by governmental authorities having jurisdiction may be displayed when in conformance to sign construction and graphic requirements specified in this Section.
 - 1. Architect may review such signs. If so, review will be for sign construction, and graphic designs only.

2. Adequacy of signage for safety and conformance to requirements of authorities having jurisdiction and trade practices shall be solely Contractor's responsibility.
- C. Painted informational signs of same colors and lettering as Project Identification sign, or standard products; size lettering to provide legibility at 100 foot distance.
 1. Colors shall be as required by authorities having jurisdiction and, if not otherwise required, of colors consistent with Project graphics.
 2. Informational signage shall be produced by professional sign painters and be of size and lettering style consistent with use.
- D. Provide at each field office, storage shed, and directional signs to direct traffic into and within site. Relocate as Work progress requires.
- E. Provide municipal traffic agency directional traffic signs to and within site.

PART 3 EXECUTION

3.01 INSTALLATION

- A. Install project identification sign within 30 days after date fixed by Notice to Proceed.
- B. Erect at location of high public visibility adjacent to main entrance to site.
- C. Erect supports and framing on secure foundation, rigidly braced and framed to resist wind loadings.
- D. Install sign surface plumb and level, with butt joints. Anchor securely.
- E. Paint exposed surfaces and edges of sign, supports, and framing for a finished appearance.
- F. Project Identification Sign Installation
 1. Construction: Construct sign support structure and install panels in durable manner, to resist high winds.
 2. Installation: Erect Sign on site at a lighted location of high public visibility, adjacent to the main entrance to the site, as approved by Architect.
 - a. Install sign at height for optimum visibility, on ground-mounted poles or attached to portable structure on skids.
 - b. Portable structure shall resist overturning force of wind.
 3. Street Address Signs: Locate and install signs at each access point from public streets.
- G. Project Informational Signs Installation:
 1. Construction: Construct sign support structure and install panels in durable manner, to resist high winds.
 2. Project Informational Signs Installation:
 - a. Locate signs as necessary for construction activities and as required by authorities having jurisdiction.
 - b. Install informational signs for optimum visibility, on ground-mounted posts or temporarily attached to surfaces of structures.
 - c. Attachment methods shall leave no permanent disfiguration or discoloration on completed Work.

3.02 MAINTENANCE

- A. Maintain signs and supports neat clean condition. Repair all deterioration, weathering and damage to structure framing, and signage.
- B. Sign Relocation: Relocate signs as required by progress of the Work.

3.03 REMOVAL

- A. Remove signs, framing, supports, and foundations at completion of Project and restore the area prior to Substantial Completion review.

END OF SECTION

SECTION 01 60 00
PRODUCT REQUIREMENTS

PART 1 GENERAL

1.01 SECTION INCLUDES

- A. General product requirements.
 - 1. System Completeness.
 - 2. Installation of Products.
- B. Transportation, handling, storage and protection.
- C. Product option requirements.
- D. Substitution limitations.
- E. Procedures for District-supplied products.
- F. Maintenance materials, including extra materials, spare parts, tools, and software.

1.02 RELATED REQUIREMENTS

- A. Section 01 10 00 - Summary: Identification of District-supplied products.
- B. Section 01 25 00 - Substitution Procedures: Substitutions made during procurement and/or construction phases.
- C. Section 01 40 00 - Quality Requirements: Product quality monitoring.
- D. Section 01 61 16 - Volatile Organic Compound (VOC) Content Restrictions: Requirements for VOC-restricted product categories.
- E. Section 01 74 19 - Construction Waste Management and Disposal: Waste disposal requirements potentially affecting product selection, packaging and substitutions.
- F. Divisions 31 - 33: Sitework.

1.03 REFERENCE STANDARDS

- A. CAL (CDPH SM) - Standard Method for the Testing and Evaluation of Volatile Organic Chemical Emissions From Indoor Sources Using Environmental Chambers.
- B. NFPA 70 - National Electrical Code.
 - 1. Use California Electrical Code.

1.04 SUBMITTALS

- A. Proposed Products List: Submit list of major products proposed for use, with name of manufacturer, trade name, and model number of each product.
 - 1. Submit within 15 days after date of Agreement.
 - 2. For products specified only by reference standards, list applicable reference standards.
- B. Product Data Submittals: Submit manufacturer's standard published data. Mark each copy to identify applicable products, models, options, and other data. Supplement manufacturers' standard data to provide information specific to this Project.

- C. Shop Drawing Submittals: Prepared specifically for this Project; indicate utility and electrical characteristics, utility connection requirements, and location of utility outlets for service for functional equipment and appliances.
- D. Sample Submittals: Illustrate functional and aesthetic characteristics of the product, with integral parts and attachment devices. Coordinate sample submittals for interfacing work.
 - 1. For selection from standard finishes, submit samples of the full range of the manufacturer's standard colors, textures, and patterns.

1.05 QUALITY ASSURANCE

- A. CAL (CDPH SM) v1.1: California Department of Public Health (CDPH) Standard Method for the Testing and Evaluation of Volatile Organic Chemical Emissions from Indoor Sources Using Environmental Chambers, v. 1.1–2010, for the emissions testing and requirements of products and materials.

PART 2 PRODUCTS

2.01 GENERAL REQUIREMENTS

- A. Drawings and Specifications:
 - 1. If a conflict exists between the Drawings and the Specifications (Project Manual), then the Contractor is to submit a Request for Interpretation from the Architect.
 - a. As noted in the General Conditions, the more stringent requirements govern, including cost of materials and/or installation.
 - 2. If a specific product is indicated on the Drawings for use, then that product is to be used without exception in the location identified.
 - 3. If the Contractor proposes the use of another product other than the item indicated, whether or not listed in these specifications, Contractor is to submit the product using the complete substitution process. See the the Article titled "SUBSTITUTIONS".
 - 4. DSA (Division of the State Architect) approval is also required prior to the use or installation of any substitution, on any product or location of product (requiring a revision to the Drawings or Specifications), included in these construction documents.
 - a. Installation of a non-approved product may result in the Contractor removing and replacing the non-approved product at the Contractor's own expense.
- B. General: Items purchased for incorporation in the Work, whether purchased for the Project or taken from previously purchased stock, and include materials, equipment, assemblies, fabrications and systems.
 - 1. Named Products: Items identified by manufacturer's product name, including make or model designations indicated in the manufacturer's published product data.
 - 2. Materials: Products that are shaped, cut, worked, mixed, finished, refined or otherwise fabricated, processed or installed to form a part of the Work.
 - 3. Equipment: A product with operating parts, whether motorized or manually operated, that requires connections such as wiring or piping.

- C. Specific Product Requirements: Refer to requirements of Section 01 40 00 - Quality Requirements and individual product technical Sections for specific requirements for products.
- D. Minimum Requirements: Specified requirements for products are minimum requirements. Refer to general requirements for quality of the Work specified in Section 01 40 00 - Quality Requirements and elsewhere herein.
- E. Standard Products:
 - 1. Where specific products are not specified, provide standard products of types and kinds that are suitable for the intended purposes and that are usually and customarily used on similar projects under similar conditions.
 - 2. Products shall be as selected by Contractor and subject to review and acceptance by the District and Architect.
- F. Product Completeness:
 - 1. Provide products complete with all accessories, trim, finish, safety guards and other devices and details needed for a complete installation and for the intended use and effect.
 - 2. Comply with additional requirements specified herein in Article titled "SYSTEM COMPLETENESS".
- G. Code Compliance:
 - 1. All products, other than commodity products prescribed by Code, are to have a current ICC Evaluation Service Research Report (ICC ESR), CABO National Evaluation Report (NER), or other testing agencies as accepted by the Division of the State Architect.
 - 2. Refer to additional requirements specified in Section 01 41 00 - Regulatory Requirements.

2.02 SYSTEM COMPLETENESS

- A. The Contract Drawings and Specifications are not intended to be comprehensive directions on how to produce the Work. Rather, the Drawings and Specifications are instruments of service prepared to describe the design intent for the completed Work.
- B. It is intended that all equipment, systems and assemblies be complete and fully functional even though not fully described. Provide all products and operations necessary to achieve the design intent described in the Contract Documents.
- C. Refer to related general requirements specified in Section 01 41 00 - Regulatory Requirements regarding compliance with minimum requirements of applicable codes, ordinances and standards.
- D. Omissions and Misdescriptions: Contractor shall report to Architect immediately when elements essential to proper execution of the Work are discovered to be missing or misdescribed in the Drawings and Specifications or if the design intent is unclear.
 - 1. Should an essential element be discovered as missing or misdescribed prior to receipt of Bids, an Addendum will be issued so that all costs may be accounted for in the Contract Sum.

2. Should an obvious omission or misdescription of a necessary element be discovered and reported after execution of the Agreement, Contractor shall provide the element as though fully and correctly described, and a no-cost Change Order shall be executed.
3. Refer to related General Requirements specified in Section 01 30 00 - Administrative Requirements and 01 31 14 - Facility Services Coordination regarding construction interfacing and coordination.

2.03 NEW PRODUCTS

- A. Provide new products unless specifically required or permitted by Contract Documents.
 1. Provide products that fully comply with the Contract Documents, are undamaged and unused at installation.
 2. Comply with additional requirements specified herein in Article titled "PRODUCT OPTIONS".
- B. See Section 01 40 00 - Quality Requirements, for additional source quality control requirements.
- C. Use of products having any of the following characteristics is not permitted:
 1. Made outside the United States, its territories, Canada, or Mexico.
 2. Containing lead, cadmium, or asbestos.
- D. Where other criteria are met, Contractor shall give preference to products that:
 1. If used on interior, have lower emissions, as defined in Section 01 61 16.
 2. If wet-applied, have lower VOC content, as defined in Section 01 61 16.
 3. Are extracted, harvested, and/or manufactured closer to the location of the project.
 4. Have longer documented life span under normal use.
 5. Result in less construction waste. See Section 01 74 19
- E. Provide interchangeable components of the same manufacture for components being replaced.
 1. To the fullest extent possible, provide products of the same kind from a single source. Products required to be supplied in quantity shall be the same product and interchangeable throughout the Work.
 2. When options are specified for the selection of any of two or more products, provide product selected to be compatible with products previously selected.
- F. Product Nameplates and Instructions:
 1. Except for required Code-compliance labels and operating and safety instructions, locate nameplates on inconspicuous, accessible surfaces. Do not attach manufacturer's identifying nameplates or trademarks on surfaces exposed to view in occupied spaces or to the exterior.
 2. Provide a permanent nameplate on each item of service-connected or power-operated equipment. Nameplates shall contain identifying information and essential operating data such as the following example:
 - a. Name of manufacturer
 - b. Name of product

- c. Model and serial number
 - d. Capacity
 - e. Operating and Power Characteristics
 - f. Labels of Tested Compliance with Codes and Standards
3. Refer to additional requirements which may be specified in various sections, as included in this Project Manual.
 4. For each item of service-connected or power-operated equipment, provide operating and safety instructions, permanently affixed and of durable construction, with legible machine lettering. Comply with all applicable requirements of authorities having jurisdiction and listing agencies.
- G. Wiring Terminations: Provide terminal lugs to match branch circuit conductor quantities, sizes, and materials indicated. Size terminal lugs to CEC/NFPA 70, include lugs for terminal box.
 - H. Cord and Plug: Provide minimum 6 foot cord and plug including grounding connector for connection to electric wiring system. Cord of longer length is specified in individual specification sections.

2.04 PRODUCT OPTIONS

- A. Unless the specifications state that no substitution is permitted, whenever the Contract Documents indicate any specific article, device, equipment, product, material, fixture, patented process, form, method, or type of construction or any specific name, make, trade name, or catalog number, with or without the words "or equal," such specification shall be deemed to be used for the purpose of facilitating description of the material, process, or article desired and shall be deemed to be followed by the words "or equal."
 1. See Section 01 25 00 - Substitution Procedures.
- B. Products Specified by Reference Standards or by Description Only: Use any product meeting those standards or description.
 1. Reference Standards:
 - a. Where Specifications require compliance with a standard, provided product shall fully comply with the standard specified.
 - b. Refer to general requirements specified in Section 01 42 19 - Reference Standards regarding compliance with referenced standards, standard specifications, codes, practices and requirements for products.
 2. Product Description:
 - a. Where Specifications describe a product, listing characteristics required, with or without use of a brand name, provide a product that has the specified attributes and otherwise complies with specified requirements.
 3. Performance Requirements:
 - a. Where Specifications require compliance with performance requirements, provide product(s) that comply and are recommended by the manufacturer for the intended application.
 - b. Verification of manufacturer's recommendations may be by product literature or by certification of performance from manufacturer.

- C. Products Specified by Naming One or More Manufacturers with a Provision for Substitutions: Submit a request for substitution for any manufacturer not named.
- D. Products Specified by Identification of Manufacturer and Product Name or Number:
 - 1. "Specified Manufacturer": Provide the specified product(s) of the specified manufacturer.
 - a. If only one manufacturer is specified, without "acceptable manufacturers" being identified, provide only the specified product(s) of the specified manufacturer.
 - b. If District standard is indicated make all efforts to provide that product.
 - c. If the phrase "or equal" or "approved equal" is stated or reference is made to the "or equal provision," products of other manufacturers may be provided if such products are equivalent to the specified product(s) of the specified manufacturer.
 - 1) Equivalence shall be demonstrated by submission of information in compliance with requirements of Section 01 25 00 - Substitution Procedures.
 - 2. "Acceptable Manufacturers":
 - a. Product(s) of the named manufacturers, if equivalent to the specified product(s) of the specified manufacturer, will be acceptable in accordance with the requirements of Section 01 25 00 - Substitution Procedures.
 - 1) Exception: Considerations regarding changes in Contract Time and Contract Sum will be waived if no increase in Contract Time or Contract Sum results from use of such equivalent products.
 - 3. Unnamed manufacturers: Product(s) of unnamed manufacturers will be acceptable when disclosed during the bidding period and only as follows:
 - a. Unless specifically stated that substitutions will not be accepted or considered, the phrase "or equal" shall be assumed to be included in the description of specified product(s).
 - b. Equivalent products of unnamed manufacturers will be accepted in accordance with the "or equal" provision specified herein, below.
 - c. If provided, products of unnamed manufacturers shall be subject to the requirements of Section 01 25 00 - Substitution Procedures.
 - 4. Quality basis:
 - a. Specified product(s) of the specified manufacturer shall serve as the basis by which products by named acceptable manufacturers and products of unnamed manufacturers will be evaluated.
 - b. Where characteristics of the specified product are described, where performance characteristics are identified or where reference is made to industry standards, such characteristics are specified to identify the most significant attributes of the specified product(s) which will be used to evaluate products of other manufacturers.
- E. Products Specified by Combination of Methods: Where products are specified by a combination of attributes, including manufacturer's name, product brand name, product catalog or identification number, industry reference standard, or description of product characteristics, provide products conforming to all specified attributes.
- F. "Or Equal" Provision: Where the phrase "or equal" or the phrase "or approved equal" is included, equivalent product(s) of unnamed manufacturer(s) may be provided as specified

above in subparagraph titled "Unnamed manufacturers" and Section 01 25 00 - Substitution Procedures with the following conditions:

1. The requirements of Section 01 25 00 - Substitution Procedures applies to products provided under the "or equal" provision.
 - a. Exception: If the proposed product(s) are determined to be equivalent to the specified product(s) of the specified manufacturer, the requirement specified for substitutions to result in a net reduction in Contract Time or Contract Sum will be waived.
 2. Use of product(s) under the "or equal" provision shall not result in any delay in completion of the Work, including completion of portions of the Work for use by District or for work under separate contract by District.
 3. Use of product(s) under the "or equal" provision shall not result in any costs to the District, including design fees and permit and plan check fees.
 4. Use of product(s) under the "or equal" provision shall not require substantial change in the intent of the design, in the opinion of the Architect.
 - a. The intent of the design shall include functional performance and aesthetic qualities.
 5. The determination of equivalence will be made by the Architect and District, and such determination shall be final.
- G. Visual Matching:
1. Where Specifications require matching a sample, the decision by the Architect on whether a proposed product matches shall be final.
 2. Where no product visually matches but the product complies with other requirements, comply with provisions for substitutions for selection of a matching product in another category.
- H. Visual Selection of Products:
1. Where requirements include the phrase "as selected from manufacturer's standard colors, patterns and textures", or a similar phrase, selections of products will be made by indicated party or, if not indicated, by the Architect. The will select color, pattern and texture from the product line of submitted manufacturer, if all other specified provisions are met.
 2. The Architect will select color, pattern and texture from the product line of submitted manufacturer, if all other specified provisions are met.

2.05 MAINTENANCE MATERIALS

- A. Furnish extra materials, spare parts, tools, and software of types and in quantities specified in individual specification sections.
- B. Deliver to Project site; obtain receipt prior to final payment.

PART 3 EXECUTION

3.01 SUBSTITUTION LIMITATIONS

- A. See Section 01 25 00 - Substitution Procedures.

3.02 OWNER-SUPPLIED PRODUCTS

- A. See Section 01 10 00 - Summary for identification of District-supplied products.
- B. District's Responsibilities:
 - 1. Arrange for and deliver District reviewed shop drawings, product data, and samples, to Contractor.
 - 2. Arrange and pay for product delivery to site.
 - 3. On delivery, inspect products jointly with Contractor.
 - 4. Submit claims for transportation damage and replace damaged, defective, or deficient items.
 - 5. Arrange for manufacturers' warranties, inspections, and service.
- C. Contractor's Responsibilities:
 - 1. Review District reviewed shop drawings, product data, and samples.
 - 2. Receive and unload products at site; inspect for completeness or damage jointly with District.
 - 3. Handle, store, install and finish products.
 - 4. Repair or replace items damaged after receipt.

3.03 TRANSPORTATION AND HANDLING

- A. Package products for shipment in manner to prevent damage; for equipment, package to avoid loss of factory calibration.
- B. If special precautions are required, attach instructions prominently and legibly on outside of packaging.
- C. Coordinate schedule of product delivery to designated prepared areas in order to minimize site storage time and potential damage to stored materials.
 - 1. Schedule delivery to minimize long-term storage and prevent overcrowding construction spaces.
 - 2. Coordinate with installation to ensure minimum holding time for items that are flammable, hazardous, easily damaged, or sensitive to deterioration, theft and other losses.
- D. Transport and handle products in accordance with manufacturer's instructions.
- E. Transport products by methods to avoid product damage.
- F. Transport materials in covered trucks to prevent contamination of product and littering of surrounding areas.
- G. Promptly inspect shipments to ensure that products comply with requirements, quantities are correct, and products are undamaged.
- H. Provide equipment and personnel to handle products by methods to prevent soiling, disfigurement, or damage, and to minimize handling.
- I. Arrange for the return of packing materials, such as wood pallets, where economically feasible.

3.04 STORAGE AND PROTECTION

- A. Provide protection of stored materials and products against theft, casualty, or deterioration.
- B. Designate receiving/storage areas for incoming products so that they are delivered according to installation schedule and placed convenient to work area in order to minimize waste due to excessive materials handling and misapplication. See Section 01 74 19.
 - 1. Structural Loading Limitations: Handle and store products and materials so as not to exceed static and dynamic load-bearing capacities of project floor and roof areas.
- C. Inspection Provisions: Arrange storage to provide access for inspection and measurement of quantity or counting of units.
- D. Structural Considerations: Store heavy materials away from the structure in a manner that will not endanger supporting construction.
- E. Store and protect products in accordance with manufacturers' instructions.
- F. Store with seals and labels intact and legible.
- G. Arrange storage of materials and products to allow for visual inspection for the purpose of determination of quantities, amounts, and unit counts.
- H. Store sensitive products in weathertight, climate-controlled enclosures in an environment favorable to product.
- I. For exterior storage of fabricated products, place on sloped supports above ground.
 - 1. Place products on raised blocks, pallets or other supports, above ground and in a manner to not create ponding or misdirection of runoff.
- J. Provide bonded off-site storage and protection when site does not permit on-site storage or protection.
- K. Protect products from damage or deterioration due to construction operations, weather, precipitation, humidity, temperature, sunlight and ultraviolet light, dirt, dust, and other contaminants.
 - 1. Periodically inspect to ensure products are undamaged, and are maintained under required conditions.
 - 2. Remove and replace products damaged by improper storage or protection with new products at no change in Contract Sum or Contract Time.
 - 3. Weather-Resistant Storage:
 - a. Store moisture-sensitive products above ground, under cover in a weathertight enclosure or covered with an impervious sheet covering. Provide adequate ventilation to avoid condensation.
 - b. Maintain storage within temperature and humidity ranges required by manufacturer's instructions.
 - c. Store loose granular materials on solid surfaces in a well-drained area. Prevent mixing with foreign matter.
- L. Comply with manufacturer's warranty conditions, if any.
- M. Do not store products directly on the ground.
- N. Cover products subject to deterioration with impervious sheet covering. Provide ventilation to prevent condensation and degradation of products.

- O. Store loose granular materials on solid flat surfaces in a well-drained area. Prevent mixing with foreign matter.
- P. Prevent contact with material that may cause corrosion, discoloration, or staining.
- Q. Provide equipment and personnel to store products by methods to prevent soiling, disfigurement, or damage.
- R. Arrange storage of products to permit access for inspection. Periodically inspect to verify products are undamaged and are maintained in acceptable condition.

3.05 INSTALLATION OF PRODUCTS

- A. Comply with manufacturer's instructions and recommendations for installation of products, except where more stringent requirements are specified, are necessary due to Project conditions or are required by authorities having jurisdiction.
- B. Anchor each product securely in place, accurately located and aligned with other Work.
- C. Clean exposed surfaces and provide protection to ensure freedom from damage and deterioration at time of Substantial Completion review. Refer to additional requirements specified in General Conditions, Section 01 50 00 - Temporary Construction Facilities and Controls and 01 70 00 - Execution and Closeout Requirements.

3.06 PROTECTION OF COMPLETED WORK

- A. Provide barriers, substantial coverings and notices to protect installed Work from traffic and subsequent construction operations.
- B. Remove protective measures when no longer required and prior to Substantial Completion review of the Work.
- C. Comply with additional requirements specified in Section 01 50 00 - Temporary Construction Facilities and Controls.

END OF SECTION

SECTION 01 61 16
VOLATILE ORGANIC COMPOUND (VOC) CONTENT RESTRICTIONS

PART 1 GENERAL

1.01 SECTION INCLUDES

- A. Requirements for Indoor-Emissions-Restricted products.
- B. Requirements for VOC-Content-Restricted products.
- C. Requirement for installer certification that they did not use any non-compliant products.

1.02 RELATED REQUIREMENTS

- A. Section 01 30 00 - Administrative Requirements: Submittal procedures.
- B. Section 01 40 00 - Quality Requirements: Procedures for testing and certifications.
- C. Section 01 60 00 - Product Requirements: Fundamental product requirements, substitutions and product options, delivery, storage, and handling.
- D. Section 07 92 00 - Joint Sealants: Emissions-compliant sealants.

1.03 DEFINITIONS

- A. Indoor-Emissions-Restricted Products: All products in the following product categories, whether specified or not:
 - 1. Interior paints and coatings applied on site.
 - 2. Interior adhesives and sealants applied on site, including flooring adhesives.
 - 3. Flooring.
 - 4. Products making up wall and ceiling assemblies.
 - 5. Thermal and acoustical insulation.
 - 6. Other products when specifically stated in the specifications.
- B. VOC-Content-Restricted Products: All products in the following product categories, whether specified or not:
 - 1. Exterior and interior paints and coatings.
 - 2. Exterior and interior adhesives and sealants, including flooring adhesives.
 - 3. Wet-applied roofing and waterproofing.
 - 4. Other products when specifically stated in the specifications.
- C. Interior of Building: Anywhere inside the exterior weather barrier.
- D. Adhesives: All gunnable, trowelable, liquid-applied, and aerosol adhesives, whether specified or not; including flooring adhesives, resilient base adhesives, and pipe jointing adhesives.
- E. Sealants: All gunnable, trowelable, and liquid-applied joint sealants and sealant primers, whether specified or not; including firestopping sealants and duct joint sealers.
- F. Inherently Non-Emitting Materials: Products composed wholly of minerals or metals, unless they include organic-based surface coatings, binders, or sealants; and specifically the following:

1. Concrete.
2. Clay brick.
3. Metals that are plated, anodized, or powder-coated.
4. Glass.
5. Ceramics.
6. Solid wood flooring that is unfinished and untreated.

1.04 REFERENCE STANDARDS

- A. 40 CFR 59, Subpart D - National Volatile Organic Compound Emission Standards for Architectural Coatings; U.S. Environmental Protection Agency.
- B. ASTM D3960 - Standard Practice for Determining Volatile Organic Compound (VOC) Content of Paints and Related Coatings.
- C. CAL (CDPH SM) - Standard Method for the Testing and Evaluation of Volatile Organic Chemical Emissions From Indoor Sources Using Environmental Chambers.
- D. CARB (ATCM) - Airborne Toxic Control Measure to Reduce Formaldehyde Emissions from Composite Wood Products; California Air Resources Board.
- E. CARB (SCM) - Suggested Control Measure for Architectural Coatings; California Air Resources Board.
- F. CHPS (HPPD) - High Performance Products Database.
- G. CRI (GL) - Green Label Testing Program - Certified Products.
- H. CRI (GLP) - Green Label Plus Testing Program - Certified Products.
- I. GreenSeal GS-36 - Adhesives for Commercial Use.
- J. SCAQMD 1113 - Architectural Coatings.
- K. SCAQMD 1168 - Adhesive and Sealant Applications.
- L. SCS (CPD) - SCS Certified Products.
- M. UL (GGG) - GREENGUARD Gold Certified Products.

1.05 SUBMITTALS

- A. See Section 01 30 00 - Administrative Requirements, for submittal procedures.
- B. Product Data: For each VOC-restricted product used in the project, submit evidence of compliance.
- C. Installer Certifications Regarding Prohibited Content: Require each installer of any type of product (not just the products for which VOC restrictions are specified) to certify that either 1) no adhesives, joint sealants, paints, coatings, or composite wood or agrifiber products have been used in the installation of installer's products, or 2) that such products used comply with these requirements.
 1. Use the form following this section for installer certifications.
- D. Verification of compliance with VOC limits as specified in the CalGreen Code Section 5.504 shall be provided at the request of the Building Inspector.
 1. Product certification and specifications.

2. Chain of custody certifications.
3. Product, labeled and invoiced as meeting the Composite Wood Products regulation.
4. Exterior grade products marked as meeting the PS-1 or PS-2 standards of the Engineered Wood Association, the Australian AS/NZS 2269 or European 636 3S standards
5. Other methods approved by the building official.

1.06 QUALITY ASSURANCE

- A. Indoor Emissions Standard and Test Method: CAL (CDPH SM), using Standard Private Office exposure scenario and the allowable concentrations specified in the method, and range of total VOC's after 14 days.
 1. Wet-Applied Products: State amount applied in mass per surface area.
 2. Paints and Coatings: Test tinted products, not just tinting bases.
 3. Evidence of Compliance: Acceptable types of evidence are the following;
 - a. Current UL (GGG) certification.
 - b. Current SCS (CPD) Floorscore certification.
 - c. Current SCS (CPD) Indoor Advantage Gold certification.
 - d. Current listing in CHPS (HPPD) as a low-emitting product.
 - e. Current CRI (GLP) certification.
 - f. Test report showing compliance and stating exposure scenario used.
 4. Product data submittal showing VOC content is NOT acceptable evidence.
 5. Manufacturer's certification without test report by independent agency is NOT acceptable evidence.
- B. VOC Content Test Method: 40 CFR 59, Subpart D (EPA Method 24), or ASTM D3960, unless otherwise indicated.
 1. Evidence of Compliance: Acceptable types of evidence are:
 - a. Report of laboratory testing performed in accordance with requirements.
 - b. Published product data showing compliance with requirements.
 - c. Certification by manufacturer that product complies with requirements.
- C. Composite Wood Emissions Standard: CARB (ATCM) for ultra-low emitting formaldehyde (ULEF) resins.
 1. Evidence of Compliance: Acceptable types of evidence are:
 - a. Current SCS "No Added Formaldehyde (NAF)" certification; www.scs-certified.com.
 - b. Report of laboratory testing performed in accordance with requirements.
 - c. Published product data showing compliance with requirements.
 - d. Certification by manufacturer that product complies with requirements.
- D. Testing Agency Qualifications: Independent firm specializing in performing testing and inspections of the type specified in this section.

PART 2 PRODUCTS

2.01 REGULATORY REQUIREMENTS

- A. All VOC restricted products shall be compliant with local jurisdiction, South Coast Air Quality Management District, Air Pollution Control District, County of San Diego, and California Green Standards Code, Rules and Regulations in effect at the time of installation. Products specified in this project shall be used as a basis of design. Updated products that are compliant with the rules in force at the time of installation shall be submitted as substitutions when they become available.
 - 1. If a product is found to be non-compliant with the VOC rules at the scheduled time of installation, notify the Architect a minimum of 90 days prior to installation. Contractor shall submit a suggested compliant product that is equal to the performance and cost of the specified product using the substitution procedure.

2.02 MATERIALS

- A. All Products: Comply with the most stringent of federal, State, and local requirements, or these specifications.
- B. Indoor-Emissions-Restricted Products: Comply with Indoor Emissions Standard and Test Method, except for:
 - 1. Composite Wood, Wood Fiber, and Wood Chip Products: Comply with Composite Wood Emissions Standard or contain no added formaldehyde resins.
 - a. Comply with CalGreen Building Standards Section 5.504.4.5, Table 504.4.4.5 "Formaldehyde Limits".
 - 2. Inherently Non-Emitting Materials.
- C. VOC-Content-Restricted Products: VOC content not greater than required by the following:
 - 1. Adhesives, Including Flooring Adhesives: SCAQMD 1168 Rule.
 - 2. Aerosol Adhesives: GreenSeal GS-36.
 - 3. Joint Sealants: SCAQMD 1168 Rule.
 - 4. Paints and Coatings: Each color; most stringent of the following:
 - a. 40 CFR 59, Subpart D.
 - b. SCAQMD 1113 Rule.
 - c. CARB (SCM).
 - d. CalGreen Building Standards Section 5.504, Table 504.4.3 "VOC Content Limits for Architectural Coatings".
 - e. Clear Wood Finishes, Floor Coatings, Stains, Primers and Shellacs: Do not exceed the VOC content limits established in SCAQMD 1113 rule.
 - 5. Wet-Applied Roofing and Waterproofing: Comply with requirements for paints and coatings.
 - 6. Carpet, Carpet Tile, and Adhesive: Provide products having VOC content not greater than that required for CRI (GLP) certification.

- a. Comply with CalGreen Building Standards Section 5.504, Table 504.4.1 "Adhesive VOC Limit".
- 7. Carpet Cushion: Provide products having VOC content not greater than that required for CRI (GL) certification.
 - a. Comply with CalGreen Building Standards Section 5.504, Table 504.4.1 "Adhesive VOC Limit".
- D. Other Product Categories: Comply with limitations specified elsewhere.

PART 3 EXECUTION

3.01 FIELD QUALITY CONTROL

- A. District reserves the right to reject non-compliant products, whether installed or not, and require their removal and replacement with compliant products at no extra cost to District.
- B. Additional costs to restore indoor air quality due to installation of non-compliant products will be borne by Contractor.

END OF SECTION

SECTION 01 61 16.01

ACCESSORY MATERIAL VOC CONTENT CERTIFICATION FORM

.01 FORM

A. Identification:

- 1. Project Name: Interim Housing
- 2. Project No.: 21056.00
- 3. Architect: tBP/Architecture

B. Use of This Form:

- 1. Because installers are allowed and directed to choose accessory materials suitable for the applicable installation, there is a possibility that such accessory materials might contain VOC content in excess of that permitted, especially where such materials have not been explicitly specified.
 - a. Each installer of work on this project is required to certify that his/their use of these particular materials complies with the contract documents and to provide documentation showing that the products used do not contain the prohibited content.
- 2. Contractor is required to obtain and submit this form from each installer of work on this project.
- 3. For each product category listed, check the correct paragraph.
- 4. If any of these accessory materials has been used, attach to this form product data and MSDS sheet for each such product.

C. VOC content restrictions are specified in Section 01 61 16.

- 1. Volatile organic compounds (VOCs) are defined by the U.S. EPA, California Air Resources Board (CARB), South Coast Air Quality Management District (SCAQMD), along with other state and local regulations applicable to this project.

1.01 PRODUCT CERTIFICATION

A. I certify that the installation work of my firm on this project:

- 1. [HAS] [HAS NOT] required the use of any ADHESIVES.
- 2. [HAS] [HAS NOT] required the use of any JOINT SEALANTS.
- 3. [HAS] [HAS NOT] required the use of any PAINTS OR COATINGS.
- 4. [HAS] [HAS NOT] required the use of any COMPOSITE WOOD or AGRIFIBER PRODUCTS.

B. Product data and MSDS sheets are attached.

2.01 CERTIFIED BY: (INSTALLER/MANUFACTURER/SUPPLIER FIRM)

A. Firm Name: _____

- B. Print Name: _____
- C. Signature: _____
- D. Title: _____ (officer of company)
- E. Date: _____

END OF SECTION

SECTION 01 70 00
EXECUTION AND CLOSEOUT REQUIREMENTS

PART 1 GENERAL

1.01 SECTION INCLUDES

- A. Examination, preparation, and general installation procedures.
- B. Requirements for alterations work, including selective demolition, except removal, disposal, and/or remediation of hazardous materials and toxic substances.
- C. Pre-installation meetings.
- D. Cutting and patching.
- E. Surveying for laying out the work.
- F. Cleaning and protection.
- G. Starting of systems and equipment.
- H. Demonstration and instruction of District personnel.
- I. Closeout procedures, including Contractor's Correction Punch List, except payment procedures.
- J. General requirements for maintenance service.

1.02 RELATED REQUIREMENTS

- A. Section 01 10 00 - Summary: Limitations on working in existing building; continued occupancy; work sequence; identification of salvaged and relocated materials.
- B. Section 01 30 00 - Administrative Requirements: Submittals procedures.
- C. Section 01 31 14 - Facility Services Coordination: Coordination of trades and BIM documents.
- D. Section 01 40 00 - Quality Requirements: Testing and inspection procedures.
- E. Section 01 45 33 - Code-Required Special Inspections: Construction oversight procedures by DSA regarding the execution, approval, and closeout of this building project.
- F. Section 01 50 00 - Temporary Facilities and Controls: Temporary exterior enclosures.
- G. Section 01 50 00 - Temporary Facilities and Controls: Temporary interior partitions.
- H. Section 01 74 19 - Construction Waste Management and Disposal: Additional procedures for trash/waste removal, recycling, salvage, and reuse.
- I. Section 01 78 00 - Closeout Submittals: Project record documents, operation and maintenance data, warranties, and bonds.
- J. Section 01 79 00 - Demonstration and Training: Demonstration of products and systems to be commissioned and where indicated in specific specification sections
- K. Section 02 41 00 - Demolition: Demolition of whole structures and parts thereof; site utility demolition.
- L. Section 07 84 00 - Firestopping.
- M. Individual Product Specification Sections:
 - 1. Advance notification to other sections of openings required in work of those sections.

2. Limitations on cutting structural members.

1.03 REFERENCE STANDARDS

- A. CFC Ch. 33 - Fire Safety During Construction and Demolition.
- B. CFC Ch. 35 - California Fire Code - Chapter 35 - Welding and Other Hot Work.
- C. NFPA 241 - Standard for Safeguarding Construction, Alteration, and Demolition Operations.

1.04 SUBMITTALS

- A. See Section 01 30 00 - Administrative Requirements, for submittal procedures.
- B. Survey work: Submit name, address, and telephone number of Surveyor before starting survey work.
 1. On request, submit documentation verifying accuracy of survey work.
 2. Submit a copy of site drawing signed by the Land Surveyor, that the elevations and locations of the work are in compliance with Contract Documents.
 3. Submit surveys and survey logs for the project record.
- C. Cutting and Patching: Submit written request in advance of cutting or alteration that affects:
 1. Structural integrity of any element of Project.
 2. Integrity of weather exposed or moisture resistant element.
 3. Efficiency, maintenance, or safety of any operational element.
 4. Visual qualities of sight exposed elements.
 5. Work of District or separate Contractor.
 6. Include in request:
 - a. Identification of Project.
 - b. Location and description of affected work. Include shop drawings as necessary to identify locations and communicate descriptions.
 - c. Necessity for cutting or alteration.
 - d. Description of proposed work and products to be used.
 - e. Effect on work of District or separate Contractor.
 - f. Effect on existing construction of District and, if applicable, work for Project being provided by District under separate contract.
 - g. Written permission of affected separate Contractor.
 - h. Date and time work will be executed.
 7. Include written evidence that those performing work under separate contract for District have been notified and acknowledge that cutting and patching work will be occurring. Include written permission for intended cutting and patching, included scheduled times.
- D. Project Record Documents: Accurately record actual locations of capped and active utilities.

1.05 QUALIFICATIONS

- A. For demolition work, employ a firm specializing in the type of work required.
 1. Minimum of 5 years of documented experience.

- B. For surveying work, employ a land surveyor registered in California and acceptable to Architect. Submit evidence of surveyor's Errors and Omissions insurance coverage in the form of an Insurance Certificate. Employ only individual(s) trained and experienced in collecting and recording accurate data relevant to ongoing construction activities,
- C. For field engineering, employ a professional engineer of the discipline required for specific service on Project, licensed in California. Employ only individual(s) trained and experienced in establishing and maintaining horizontal and vertical control points necessary for laying out construction work on project of similar size, scope and/or complexity.
- D. For design of temporary shoring and bracing, employ a Professional Engineer experienced in design of this type of work and licensed in California.

1.06 PROJECT CONDITIONS

- A. Grade site to drain. Maintain excavations free of water. Provide, operate, and maintain pumping equipment.
- B. Protect site from puddling or running water.
- C. Ventilate enclosed areas to assist cure of materials, to dissipate humidity, and to prevent accumulation of dust, fumes, vapors, or gases.
- D. Dust Control: Execute work by methods to minimize raising dust from construction operations. Provide positive means to prevent air-borne dust from dispersing into atmosphere and over adjacent property.
 - 1. Provide dust-proof enclosures to prevent entry of dust generated outdoors.
- E. Erosion and Sediment Control: Plan and execute work by methods to control surface drainage from cuts and fills, from borrow and waste disposal areas. Prevent erosion and sedimentation.
 - 1. Minimize amount of bare soil exposed at one time.
 - 2. Provide temporary measures such as berms, dikes, and drains, to prevent water flow.
 - 3. Construct fill and waste areas by selective placement to avoid erosive surface silts or clays.
 - 4. Periodically inspect earthwork to detect evidence of erosion and sedimentation; promptly apply corrective measures.
- F. Noise Control: Provide methods, means, and facilities to minimize noise produced by construction operations.
 - 1. At All Times: Excessively noisy tools and operations will not be tolerated inside the building at any time of day; excessively noisy includes jackhammers.
 - 2. Outdoors: Limit conduct of especially noisy exterior work to the hours of 8 am to 5 pm.
- G. Pest and Rodent Control: Provide methods, means, and facilities to prevent pests and insects from damaging the work.
- H. Rodent Control: Provide methods, means, and facilities to prevent rodents from accessing or invading premises.
- I. Pollution Control: Provide methods, means, and facilities to prevent contamination of soil, water, and atmosphere from discharge of noxious, toxic substances, and pollutants produced by construction operations. Comply with federal, state, and local regulations.

1.07 COORDINATION

- A. See Section 01 10 00 for occupancy-related requirements.
- B. Coordinate scheduling, submittals, and work of the various sections of the Project Manual to ensure efficient and orderly sequence of installation of interdependent construction elements, with provisions for accommodating items installed later.
- C. Notify affected utility companies and comply with their requirements.
- D. Verify that utility requirements and characteristics of new operating equipment are compatible with building utilities. Coordinate work of various sections having interdependent responsibilities for installing, connecting to, and placing in service, such equipment.
- E. Coordinate space requirements, supports, and installation of mechanical and electrical work that are indicated diagrammatically on drawings. Follow routing indicated for pipes, ducts, and conduit, as closely as practicable; place runs parallel with lines of building. Utilize spaces efficiently to maximize accessibility for other installations, for maintenance, and for repairs.
- F. In finished areas except as otherwise indicated, conceal pipes, ducts, and wiring within the construction. Coordinate locations of fixtures and outlets with finish elements.
- G. Coordinate completion and clean-up of work of separate sections.
- H. After District occupancy of premises, coordinate access to site for correction of defective work and work not in accordance with Contract Documents, to minimize disruption of District's activities.

PART 2 PRODUCTS

2.01 PATCHING MATERIALS

- A. New Materials: As specified in product sections; match existing products and work for patching and extending work.
- B. Type and Quality of Existing Products: Determine by inspecting and testing products where necessary, referring to existing work as a standard.
- C. Product Substitution: For any proposed change in materials, submit request for substitution described in Section 01 60 00 - Product Requirements.

PART 3 EXECUTION

3.01 EXAMINATION

- A. Verify that existing conditions and substrate surfaces are acceptable for subsequent work. Start of work means acceptance of existing conditions.
- B. Verify that existing substrate is capable of structural support or attachment of new work being applied or attached.
- C. Examine and verify specific conditions described in individual specification sections.
- D. Take field measurements before confirming product orders or beginning fabrication, to minimize waste due to over-ordering or misfabrication.
- E. Verify that utility services are available, of the correct characteristics, and in the correct locations.

- F. Prior to Cutting: Examine existing conditions prior to commencing work, including elements subject to damage or movement during cutting and patching. After uncovering existing work, assess conditions affecting performance of work. Beginning of cutting or patching means acceptance of existing conditions.

3.02 PREPARATION

- A. Clean substrate surfaces prior to applying next material or substance.
- B. Seal cracks or openings of substrate prior to applying next material or substance.
- C. Apply manufacturer required or recommended substrate primer, sealer, or conditioner prior to applying any new material or substance in contact or bond.
- D. Temporary Supports: Provide supports to ensure structural integrity of the Work. Provide devices and methods to protect other portions of Project from damage.
- E. Weather Protection: Provide protection from elements for areas which may be exposed by uncovering Work. Maintain excavations free of water.

3.03 PREINSTALLATION MEETINGS

- A. When required in individual specification sections, convene a preinstallation meeting at the site prior to commencing work of the section.
 - 1. Coordinate operations of the various trades to assure efficient and orderly installation of each part of Work.
 - 2. Coordinate Work operations of the various trades that depend on each other for proper installation, connection, and operation of Work, including but not limited to:
 - a. Schedule construction operations in sequence required where installation of one part of Work depends on installation of other components, before or after its own installation.
 - b. Coordinate installation of different components to assure maximum accessibility for required maintenance, service, and repair.
 - c. Provide provisions to accommodate items scheduled for later installation.
 - 3. Prepare and administer coordination drawings. Refer to Section 01 31 14 - Facility Services Coordination.
- B. Require attendance of parties directly affecting, or affected by, work of the specific section.
- C. Notify Architect four days in advance of meeting date.
- D. Prepare agenda and preside at meeting:
 - 1. Review conditions of examination, preparation and installation procedures.
 - 2. Review coordination with related work.
- E. Record minutes and distribute copies within two days after meeting to participants, with two copies to Architect, District, participants, and those affected by decisions made.

3.04 LAYING OUT THE WORK

- A. Notify the District at least 48 hours before staking is to be started.
- B. Verify locations of survey control points prior to starting work.
- C. Promptly notify Architect of any discrepancies discovered.

- D. Contractor shall locate and protect survey control and reference points.
- E. Control datum for survey is that established by District provided survey.
- F. Protect survey control points prior to starting site work; preserve permanent reference points during construction.
- G. Promptly report to Architect the loss or destruction of any reference point or relocation required because of changes in grades or other reasons.
- H. Replace dislocated survey control points based on original survey control. Make no changes without prior written notice to Architect.
- I. Utilize recognized engineering survey practices.
- J. Establish a minimum of two permanent bench marks on site, referenced to established control points. Record locations, with horizontal and vertical data, on project record documents.
- K. Establish elevations, lines and levels. Locate and lay out by instrumentation and similar appropriate means:
 - 1. Site improvements including pavements; stakes for grading, fill and topsoil placement; utility locations, slopes, and invert elevations.
 - 2. Grid or axis for structures.
 - 3. Building foundation, column locations, ground floor elevations.
- L. Periodically verify layouts by same means.
- M. Maintain a complete and accurate log of control and survey work as it progresses.
- N. On completion of foundation walls and major site improvements, prepare a certified survey illustrating dimensions, locations, angles, and elevations of construction and site work.

3.05 GENERAL INSTALLATION REQUIREMENTS

- A. Dimensions for Accessibility:
 - 1. Conventions: See CBC Figure 11B-104. Dimensions that are not stated as "maximum" or "minimum" are absolute.
 - 2. Tolerances shall be per CBC 11B-104.1.1 "Construction and manufacturing tolerances. All dimensions are subject to conventional industry tolerances except where the requirement is stated as a range with specific minimum and maximum end points."
- B. In addition to compliance with regulatory requirements, conduct construction operations in compliance with CFC Ch. 33 and NFPA 241, including applicable recommendations in Appendix A.
- C. When welding or doing other hot work, comply with CFC Ch. 35.
- D. Install products as specified in individual sections, in accordance with manufacturer's instructions and recommendations, and so as to avoid waste due to necessity for replacement.
- E. Make vertical elements plumb and horizontal elements level, unless otherwise indicated.
- F. Install equipment and fittings plumb and level, neatly aligned with adjacent vertical and horizontal lines, unless otherwise indicated.
- G. Make consistent texture on surfaces, with seamless transitions, unless otherwise indicated.

- H. Make neat transitions between different surfaces, maintaining texture and appearance.

3.06 ALTERATIONS

- A. Drawings showing existing construction and utilities are based on casual field observation and existing record documents only.
 - 1. Verify that construction and utility arrangements are as indicated.
 - 2. Report discrepancies to Architect before disturbing existing installation.
 - 3. Beginning of alterations work constitutes acceptance of existing conditions.
- B. Keep areas in which alterations are being conducted separated from other areas that are still occupied.
 - 1. Provide, erect, and maintain temporary dustproof partitions of construction specified in Section 01 50 00 .
- C. Maintain weatherproof exterior building enclosure except for interruptions required for replacement or modifications; take care to prevent water and humidity damage.
 - 1. Where openings in exterior enclosure exist, provide construction to make exterior enclosure weatherproof.
 - 2. Insulate existing ducts or pipes that are exposed to outdoor ambient temperatures by alterations work.
- D. Remove existing work as indicated and as required to accomplish new work.
 - 1. Remove rotted wood, corroded metals, and deteriorated masonry and concrete; replace with new construction specified.
 - 2. Remove items indicated on drawings.
 - 3. Relocate items indicated on drawings.
 - 4. Where new surface finishes are to be applied to existing work, perform removals, patch, and prepare existing surfaces as required to receive new finish; remove existing finish if necessary for successful application of new finish.
 - 5. Where new surface finishes are not specified or indicated, patch holes and damaged surfaces to match adjacent finished surfaces as closely as possible.
- E. Services (Including but not limited to HVAC, Plumbing, Fire Protection, Electrical, and Telecommunications): Remove, relocate, and extend existing systems to accommodate new construction.
 - 1. Maintain existing active systems that are to remain in operation; maintain access to equipment and operational components; if necessary, modify installation to allow access or provide access panel.
 - 2. Where existing systems or equipment are not active and Contract Documents require reactivation, put back into operational condition; repair supply, distribution, and equipment as required.
 - 3. Where existing active systems serve occupied facilities but are to be replaced with new services, maintain existing systems in service until new systems are complete and ready for service.

- a. Disable existing systems only to make switchovers and connections; minimize duration of outages.
 - b. Provide temporary connections as required to maintain existing systems in service.
- 4. Verify that abandoned services serve only abandoned facilities.
- 5. Remove abandoned pipe, ducts, conduits, and equipment, including those above accessible ceilings; remove back to source of supply where possible, otherwise cap stub and tag with identification; patch holes left by removal using materials specified for new construction.
- F. Protect existing work to remain.
 - 1. Prevent movement of structure; provide shoring and bracing if necessary.
 - 2. Perform cutting to accomplish removals neatly and as specified for cutting new work.
 - 3. Repair adjacent construction and finishes damaged during removal work.
- G. Adapt existing work to fit new work: Make as neat and smooth transition as possible.
 - 1. When existing finished surfaces are cut so that a smooth transition with new work is not possible, terminate existing surface along a straight line at a natural line of division and make recommendation to Architect.
 - 2. Where removal of partitions or walls results in adjacent spaces becoming one, rework floors, walls, and ceilings to a smooth plane without breaks, steps, or bulkheads.
 - 3. Where a change of plane of 1/4 inch or more occurs in existing work, submit recommendation for providing a smooth transition for Architect review and request instructions.
 - 4. Trim existing wood doors as necessary to clear new floor finish. Refinish trim as required.
- H. Patching: Where the existing surface is not indicated to be refinished, patch to match the surface finish that existed prior to cutting. Where the surface is indicated to be refinished, patch so that the substrate is ready for the new finish.
- I. Refinish existing surfaces as indicated:
 - 1. Where rooms or spaces are indicated to be refinished, refinish all visible existing surfaces to remain to the specified condition for each material, with a neat transition to adjacent finishes.
 - 2. If mechanical or electrical work is exposed accidentally during the work, re-cover and refinish to match.
- J. Clean existing systems and equipment.
- K. Remove demolition debris and abandoned items from alterations areas and dispose of off-site; do not burn or bury.
- L. Do not begin new construction in alterations areas before demolition is complete.
- M. Comply with all other applicable requirements of this section.

3.07 CUTTING AND PATCHING

- A. Whenever possible, execute the work by methods that avoid cutting or patching.
- B. See Alterations article above for additional requirements.

- C. Perform whatever cutting and patching is necessary to:
 - 1. Complete the work.
 - 2. Fit products together to integrate with other work.
 - 3. Provide openings for penetration of mechanical, electrical, and other services.
 - 4. Match work that has been cut to adjacent work.
 - 5. Repair areas adjacent to cuts to required condition.
 - 6. Repair new work damaged by subsequent work.
 - 7. Remove samples of installed work for testing when requested.
 - 8. Remove and replace defective and non-complying work.
- D. Execute work by methods that avoid damage to other work and that will provide appropriate surfaces to receive patching and finishing. In existing work, minimize damage and restore to original condition.
 - 1. Coordinate installation or application of products for integrated Work.
 - 2. Uncover completed Work as necessary to install or apply products out of sequence.
 - 3. Remove and replace defective or non-conforming Work.
 - 4. Provide openings for penetration of utility services, such as plumbing, mechanical and electrical Work.
- E. After uncovering existing Work, inspect conditions affecting proper accomplishment of Work.
- F. Temporary Supports: Provide supports to ensure structural integrity of the Work. Provide devices and methods to protect other portions of Project from damage.
- G. Beginning of cutting or patching shall be interpreted to mean that existing conditions were found by Contractor to be acceptable.
- H. Employ skilled and experienced installer to perform cutting for weather exposed and moisture resistant elements, and sight exposed surfaces.
- I. Cut rigid materials using masonry saw or core drill. Pneumatic tools not allowed without prior approval.
 - 1. Use a diamond grit abrasive saw or similar cutter for smooth edges. Do not overcut corners.
- J. Restore work with new products in accordance with requirements of Contract Documents.
- K. Fit work neat and tight allowing for expansion and contraction.
- L. Fit work air tight to pipes, sleeves, ducts, conduit, and other penetrations through surfaces.
- M. At penetrations of fire rated walls, partitions, ceiling, or floor construction, completely seal voids with fire rated material in accordance with Section 07 84 00, to full thickness of the penetrated element.
- N. Patching:
 - 1. Finish patched surfaces to match finish that existed prior to patching. On continuous surfaces, refinish to nearest intersection or natural break. For an assembly, refinish entire unit.
 - 2. Match color, texture, and appearance.

3. Repair patched surfaces that are damaged, lifted, discolored, or showing other imperfections due to patching work. If defects are due to condition of substrate, repair substrate prior to repairing finish.
- O. Finishing: Refinish surfaces to match adjacent and similar finishes as used for the Project.
1. For continuous surfaces, refinish to nearest intersection or natural break.
 2. For an assembly, refinish entire unit.

3.08 PROGRESS CLEANING

- A. Maintain areas free of waste materials, debris, and rubbish. Maintain site in a clean and orderly condition.
- B. Remove debris and rubbish from pipe chases, plenums, attics, crawl spaces, and other closed or remote spaces, prior to enclosing the space.
- C. Broom and vacuum clean interior areas prior to start of surface finishing, and continue cleaning to eliminate dust.
- D. Collect and remove waste materials, debris, and trash/rubbish from site periodically and dispose off-site; do not burn or bury.

3.09 PROTECTION OF INSTALLED WORK

- A. Protect installed work from damage by construction operations.
- B. Provide special protection where specified in individual specification sections.
- C. Provide temporary and removable protection for installed products. Control activity in immediate work area to prevent damage.
- D. Provide protective coverings at walls, projections, jambs, sills, and soffits of openings.
- E. Protect finished floors, stairs, and other surfaces from traffic, dirt, wear, damage, or movement of heavy objects, by protecting with durable sheet materials.
- F. Prohibit traffic or storage upon waterproofed or roofed surfaces. If traffic or activity is necessary, obtain recommendations for protection from waterproofing or roofing material manufacturer.
- G. Remove protective coverings when no longer needed; reuse or recycle coverings if possible.

3.10 SYSTEM STARTUP

- A. Coordinate schedule for start-up of various equipment and systems.
- B. Notify Architect and Owner seven days prior to start-up of each item.
- C. Verify that each piece of equipment or system has been checked for proper lubrication, drive rotation, belt tension, control sequence, and for conditions that may cause damage.
- D. Verify tests, meter readings, and specified electrical characteristics agree with those required by the equipment or system manufacturer.
- E. Verify that wiring and support components for equipment are complete and tested.
- F. Execute start-up under supervision of applicable Contractor personnel and manufacturer's representative in accordance with manufacturers' instructions.
- G. When specified in individual specification Sections, require manufacturer to provide authorized representative to be present at site to inspect, check, and approve equipment or

system installation prior to start-up, and to supervise placing equipment or system in operation.

- H. Submit a written report that equipment or system has been properly installed and is functioning correctly.

3.11 PROJECT CLOSEOUT CONFERENCE

- A. Schedule and conduct a project closeout conference, at a time convenient to District and Architect, but no later than 90 days prior to the scheduled date of Substantial Completion.
 - 1. Conduct the conference to review requirements and responsibilities related to Project closeout.
 - 2. Attendees: Authorized representatives of District, Commissioning Authority (CxA), Architect, and relevant consultants; Contractor and project superintendent; major subcontractors; suppliers; and other concerned parties shall attend the meeting. Participants at the meeting shall be familiar with Project and authorized to conclude matters relating to the Work.
 - 3. Agenda: Discuss items of significance that could affect or delay Project closeout, including the following:
 - a. Preparation of record documents.
 - b. Commissioning.
 - c. Procedures required prior to inspection for Substantial Completion and for final inspection for acceptance.
 - d. Submittal of written warranties.
 - e. Coordination of separate contracts.
 - f. District's partial occupancy requirements.
 - g. Installation of District's furniture, fixtures, and equipment.
 - h. Responsibility for removing temporary facilities and controls.
 - 4. Record minutes and distribute copies within two days after meeting to participants, with two copies to Architect, District, participants, and those affected by decisions made.

3.12 DEMONSTRATION AND INSTRUCTION

- A. See Section 01 79 00 - Demonstration and Training.

3.13 ADJUSTING

- A. Adjust operating products and equipment to ensure smooth and unhindered operation.
- B. Testing, adjusting, and balancing HVAC systems: See Section 23 05 93 - Testing, Adjusting, and Balancing for HVAC.

3.14 FINAL CLEANING

- A. Cleaning and Disposal Requirements, General: Conduct cleaning and disposal operations in compliance with all applicable codes, ordinances and regulations, including environmental protection laws, rules and practices.
- B. Execute final cleaning prior to final project assessment.

1. Clean areas to be occupied by District prior to final completion before District occupancy.
- C. Substantial Completion Review Cleaning, General: Execute a thorough cleaning prior to Substantial Completion review by Architect and District. Employ experienced workers or professional cleaners for cleaning operations for Substantial Completion review.
- D. Use cleaning materials that are nonhazardous.
 1. Cleaning Agents and Materials: Use only those cleaning agents and materials which will not create hazards to health or property and which will not damage or degrade surfaces.
 - a. Use only those cleaning agents, materials and methods recommended by manufacturer of the material to be cleaned.
 - b. Use cleaning materials only on surfaces recommended by cleaning agent manufacturer.
 - c. Before use, review cleaning agents and materials with Construction Manager for suitability and compatibility. Use no cleaning agents and materials without approval as noted above.
 2. Cleaning Procedures: All cleaning processes, agents and materials shall be subject to Architect, District and/or Construction Manager review and approval. Processes and degree of cleanliness shall be as directed by Architect, District and/or Construction Manager.
- E. Clean interior and exterior glass, surfaces exposed to view; remove temporary labels, stains and foreign substances, polish transparent and glossy surfaces, vacuum carpeted and soft surfaces.
- F. Remove all labels that are not permanent. Do not paint or otherwise cover fire test labels or nameplates on mechanical and electrical equipment.
- G. Clean equipment and fixtures to a sanitary condition with cleaning materials appropriate to the surface and material being cleaned.
- H. Clean filters of operating equipment.
- I. Clean debris from roofs, gutters, downspouts, scuppers, overflow drains, area drains, and drainage systems.
- J. Clean site; sweep paved areas, rake clean landscaped surfaces.
- K. Remove waste, surplus materials, trash/rubbish, and construction facilities from the site; dispose of in legal manner; do not burn or bury.

3.15 CLOSEOUT PROCEDURES

- A. Clean-Up Retainage:
 1. Five (5) percent of each Contractor's bid will automatically be held in abeyance in their contract schedule of values for clean-up.
 2. If in the Construction Manager's opinion the Contractor is maintaining a clean project, a pro-rata share of this clean-up budget will be paid monthly to the Contractor in accordance with their approximate aggregate percentage of completion of the project.

3. If a Contractor fails to heed written directives to clean-up during the course of the project, the work will be done at the Contractor's expense and a deductive change order will be written against their contract with the District.
 4. The establishment of this 5 percent budget in no way limits the cost for the Contractor to maintain a clean project.
- B. Make submittals that are required by governing or other authorities.
 1. Provide copies to Architect and District.
 - C. Accompany Architect, Construction Manager, and District Representative on preliminary inspection to determine items to be listed for completion or correction in the Contractor's Correction Punch List for Contractor's comprehensive list of items to be completed or corrected.
 1. As authorized by the District; Architect and Architect's and District's consultants, as appropriate, will attend a meeting at the Project site to review Contract closeout procedures and to review the list of items to be completed and corrected (punch list) to make the Work ready for acceptance by the District.
 2. This meeting shall be scheduled not earlier than 14 days prior to the date anticipated for the Substantial Completion review.
 - D. Notify Architect when work is considered ready for Architect's Substantial Completion inspection.
 - E. Submit written certification containing Contractor's Correction Punch List, that Contract Documents have been reviewed, work has been inspected, and that work is complete in accordance with Contract Documents and ready for Architect's Substantial Completion inspection.
 1. Final Application for Payment: In the Application for Payment that coincides with the date Substantial Completion is claimed, show 100 percent completion for the portion of the Work claimed substantially complete.
 2. Warranties, Bonds and Certificates: Submit specific warranties, guarantees, workmanship bonds, maintenance agreements, final certifications and similar documents.
 3. Locks and Keys: Change temporary lock cylinders over to permanent keying and transmit keys to the District, unless otherwise directed or specified.
 4. Tests and Instructions: Complete start-up testing of systems, and instruction of the District's personnel. Remove temporary facilities from the site, along with construction tools, mock-ups, and similar elements.
 - F. Clearing and Cleaning: Prior to the Substantial Completion review, Contractor shall conduct a thorough cleaning and clearing of the Project area, including removal of construction facilities and temporary controls.
 - G. Inspection and Testing: Prior to the Substantial Completion review, complete inspection and testing required for the Work, including securing of approvals by authorities having jurisdiction.
 1. Complete all inspections, tests, balancing, sterilization and cleaning of plumbing and HVAC systems.

2. Complete inspections and tests of electrical power and signal systems.
 3. Complete inspections and tests of conveying (elevator or wheelchair lift) systems.
- H. District will occupy all of the building as specified in Section 01 10 00.
- I. Conduct Substantial Completion inspection and create Final Correction Punch List containing Architect's and Contractor's comprehensive list of items identified to be completed or corrected and submit to Architect.
1. Correction (Punch) List: Contractor shall prepare and distribute at the preliminary Contract closeout review meeting, a typewritten, comprehensive list of items to be completed and corrected (punch list) to make the Work ready for acceptance by the District.
 - a. The punch list shall include all items to be completed or corrected prior to the Contractor's application for final payment.
 - b. The punch list shall identify items by location (room number or name) and consecutive number. For example, 307-5 would identify item 5 in Room 307, Roof-4 would identify item 4 on Roof.
 - c. Contractor shall prepare separate lists according to categories used for Drawings. For example, provide lists for Architectural, Structural, Plumbing, Mechanical, Electrical, Fire Protection, Civil, and Landscape.
 - d. Architect, Architect's consultants and District's consultants, if in attendance, will conduct a brief walk-through of Project with the Contractor to review scope and adequacy of the punch list.
 - e. Verbal comments will be made to the Contractor by the Construction Manager, the Architect and the Architect's and District's consultants, if in attendance, during the walk-through. These comments will indicate generally the additions and corrections to be made to the punch list. Such comments shall not be considered to be comprehensive; Contractor shall use the comments as guidance in preparing the punch list for the Substantial Completion review.
 2. Substantial Completion Meeting: On a date mutually agreed by the District, Architect, and Contractor, a meeting shall be conducted at the Project site to determine whether the Work is satisfactory and complete for filing a Notice of Completion (Substantial Completion).
 - a. Contractor shall provide three working days notice to Architect for requested date of Substantial Completion meeting.
 - b. The Construction Manager, the Architect and the Architect's and District's consultants, as authorized by the District, will attend the Substantial Completion meeting.
 - c. In addition to conducting a walk-through of the facility and reviewing the punch list, the purpose of the meeting shall include submission of warranties, guarantees and bonds to the District, submission of operation and maintenance data (manuals), provision of specified extra materials to the District, and submission of other Contract closeout documents and materials as required and if not already submitted.

- d. The Construction Manager, the Architect and Architect's consultants, as appropriate, will conduct a walk-through of the facility with the Contractor and review the punch list.
 - e. Contractor shall correct the punch list and record additional items as may identified during the walk-through, including notations of corrective actions to be taken.
 - f. Contractor shall retype the punch list and distribute it within three working days to those attending the meeting.
 - g. If additional site visits by the Construction Manager, the Architect and the Architect's and District's consultants are required to review completion and correction of the Work, the costs of additional visits shall be reimbursed to the District by the Contractor by deducting such costs from the Final Payment.
- J. Correct items of work listed in Final Correction Punch List and comply with requirements for access to District-occupied areas.
 - K. Notify Architect when work is considered finally complete and ready for Architect's Substantial Completion final inspection.
 - 1. Architect's Certification of Substantial Completion:
 - a. When Architect determines that list of items to be completed and corrected (Punch List) is sufficiently complete for District to occupy Project for the use to which it is intended.
 - b. Architect will complete and issue to the District and Contractor a Certificate of Substantial Completion using:
 - 1) The American Institute of Architects Form G704 - Certificate of Substantial Completion
 - 2) or other form if directed by the District.
 - L. Complete items of work determined by Architect listed in executed Certificate of Substantial Completion.

3.16 FINAL PAYMENT

- A. After completion of all items listed for completion and correction, after submission of all documents and products and after final cleaning, submit final Application for Payment, identifying total adjusted Contract Sum, previous payments and sum remaining due.
- B. Payment will not be made until the following are accomplished:
 - 1. All Project Record Documents have been transferred and accepted by District.
 - 2. All extra materials and maintenance stock have been transferred and received by District.
 - 3. All warranty documents and operation and maintenance data have been received and accepted by District.
 - 4. All liens have been released or bonded by Contractor.
 - 5. Contractor's surety has consented to Final Payment.
 - 6. All documentation required by DSA has been completed.

3.17 MAINTENANCE

- A. Provide service and maintenance of components indicated in specification sections.

- B. Maintenance Period: As indicated in specification sections or, if not indicated, not less than one year from the Date of Substantial Completion or the length of the specified warranty, whichever is longer.
- C. Examine system components at a frequency consistent with reliable operation. Clean, adjust, and lubricate as required.
- D. Include systematic examination, adjustment, and lubrication of components. Repair or replace parts whenever required. Use parts produced by the manufacturer of the original component.
- E. Maintenance service shall not be assigned or transferred to any agent or subcontractor without prior written consent of the District.

END OF SECTION

SECTION 01 71 23
FIELD ENGINEERING

PART 1 – GENERAL

1.01 SECTION INCLUDES

- A. Layout of the work.
- B. Verification of work.
 - 1. Owner reserves the right to verify any work that Inspector deems necessary.
 - 2. Other sections that require Surveyor to verify or measure installed work and related item. Surveyor shall perform such verifications or measurements at Contractor's expense. Contractor shall furnish a certification, signed by both Surveyor and Contractor, to Inspector.

1.02 SURVEY CONTROLS

- A. Vertical Control shall use same benchmark used in the preparation of topographic survey. When Work consists of both on-site and off-site and benchmarks differ, an equation shall be indicated on Drawings.
- B. Horizontal control for existing structures shall be the property line.

1.03 LAYOUT OF WORK

- A. All work related to staking shall be by a Land Surveyor, or Civil engineer, registered with the State of California to perform land surveying and employed by Contractor.
- B. Before commencement of Work, surveyor shall locate all reference points and benchmarks to be used for vertical and horizontal control.
- C. Surveyor shall lay out entire Work, set grades, lines, levels, control points, elevations, grids and positions.

1.04 RECORD DOCUMENTS

- A. Maintain complete and accurate log of all control and survey documentation as work progresses.
- B. Record, by coordinates, all utilities onsite with top of pipe elevations, at major grade and alignment changes, rim, grate or top of curb and flow line elevations of all drainage structures and sewer manholes.
- C. Indicate reference and control points on record drawings. The basis of elevation shall be one of the established benchmarks.
- D. Upon Beneficial Occupancy, obtain and pay for reproducible plans. Deliver plans to District Representative. Clearly indicate all differences between original drawings and completed work within specified tolerances.

1.05 SUBMITTALS

- A. Surveyor: Shall submit name, address and license number to Owner, including any changes as they occur.
- B. Field notes: Upon request by District Representative, submit copies of cut sheets, coordinate plots, data collector printouts, marked-up construction staking plans and other documentation as available to verify accuracy of field engineering work during and at completion of project. Submittals to Owner must be signed and sealed by Surveyor and counter-signed by Contractor
- C. Statement of Compliance: Contractor shall submit a statement of certification signed and sealed by Surveyor, counter-signed by Contractor indicating compliance with grades and alignment of construction plans at rough grade, fine grade and top of rock stages. Inspector shall approve survey submittals for each stage of construction prior to proceeding with work
- D. Upon Beneficial Occupancy, Contractor shall obtain and pay for reproducible survey drawings (or "As Built").
- E. Completed record drawings shall be signed and certified as correct and within specified tolerances by licensed surveyor. Originals and two sets of blueprints shall be submitted to Owner.

PART 2 – PRODUCTS (Not used)

PART 3 – EXECUTION

3.01 PREPARATION

- A. Pre-mark areas of excavation in accordance with the requirements of "Dig-Alert". Request locators 2 days before commencing excavation.
- B. Before commencing Work, establish all horizontal and vertical reference points used in Contract Documents according to existing field conditions.
- C. Preserve established reference lines and benchmarks.
- D. Differentiate school and city datum as applicable.
- E. Relocate bench marks that may interfere with Work.
- F. Reset and re-establish reference marks damaged or lost during construction.

3.02 SURVEY REQUIREMENTS GENERAL

- A. Establish a minimum of two permanent horizontal and vertical control points on Project site, remote from construction area, referenced to data established by control points.
- B. Indicate reference points, relative to benchmark elevation, on record drawings.
- C. Provide grade stakes and elevations to construct over excavation and re-compaction, rough and final grades, paved areas, curbs, gutters, sidewalks, building pads, landscaped areas, and other areas as required.

- D. Calculate and layout proposed finished elevations and intermediate controls, as required, to provide smooth transitions between spot elevations indicated on Drawings.
- E. Provide stakes and elevations for grading, fill, and topsoil placement.
- F. Provide adequate horizontal and vertical control to locate utility lines, including but not limited to, storm, sewers, water mains, gas, electric and signal and provide vertical control in proportion to the slope of the line as required for accurate construction. Dry utilities will be based upon adequate horizontal and vertical control layout. Prior to trench closure, survey and record invert and flow line elevations. Survey and record top of curb and flow line elevations on finished concrete or asphaltic concrete (AC) surfaces at key locations such as beginning-of-curve (BC), end-of-curve (EC), grade breaks, corners or angle points in sufficient number to demonstrate the Work complies with the intent of the Contract Documents.
- G. Provide horizontal and vertical control for batter boards for drainage, utility, and other on-site structures as required.
- H. Furnish building corner offsets as required to adequately locate building pads. Provide cut and fill stakes within the building pad perimeter adequate to control both over excavation and re-compaction and the final sub-grade elevation of the building pad.
- I. Submit a certification signed by the surveyor confirming the elevations and locations of improvements are in conformance with the Contract Documents. The statement shall include survey notes for the finish floor and building pad, showing the actual measured elevations on the completed sub-grade, recorded to the nearest 0.01 of a foot. Building pad tolerance will be plus or minus 0.1 of a foot.
- J. Establish a minimum of two permanent horizontal and vertical control points on Project site, remote from building area, referenced to data established by survey control points.
- K. Mark boundaries for rights-of-way dedications and easements for utilities prior to making location of buildings and utilities.
- L. Layout all lines, elevations, and measurements needed for construction or installation of buildings, grading, paving utilities according to the following:
 - 1. Identify site boundary, property lines.
 - 2. Provide working benchmarks.
 - 3. Set stakes for Bottom of Excavated Plane (B.E.P.).
 - 4. Set gridlines, radii, working points etcetera, for foundation.
 - 5. Set and verify building pad elevations.
 - 6. Set finish floor elevations.
 - 7. Stake location and elevations for exterior ramps and stairs.
 - 8. Set gridlines, radii, working points, etcetera, for all floors of multi-story buildings.
 - 9. Set storm drain and sanitary sewer inverts and other utilities as needed at 5-foot off-set from building lines.

10. For new facilities, establish permanent onsite Benchmark with 2-inch diameter brass disk. Location of Benchmark to be determined by Owner.

3.03 SURVEY REQUIREMENTS FOR GRADING

- A. Provide grade stakes and elevations as follows:
 1. Removal limits (cut lines).
 2. Rough grade staking: 60-foot maximum grid plus additional stakes at grade changes and pertinent locations. Flag all grade changes including ridges, flow lines and grade breaks.
 3. Fine grade for top of dirt: 30-foot maximum grid plus additional stakes at grade changes and pertinent locations. Flag all grade changes including ridges, flow lines and grade breaks.
 4. Verify fine grade for top of rock: 30-foot maximum grid plus additional stakes at grade changes and pertinent locations. Flag all grade changes including ridges, flow lines and grade breaks.
 5. Finish grade marks on all buildings, structures and at pertinent locations
 6. Finish grades and offsets for all concrete work, utilities, landscape areas, and structures.
 7. Provide controls and baselines for playground striping.
 8. Offsite improvements: set grades and provide grade sheets as required by local authorities.
- B. Provide a minimum of two permanent horizontal and vertical control points onsite, remote from building area, referenced to data established by survey control points.

3.04 SURVEY REQUIREMENTS FOR UTILITIES

- A. Locate "wet" utility lines and provide vertical control proportionate to slope of line as required for accurate construction. "Dry" utilities shall have adequate horizontal and vertical control layout supplied by others.
- B. Prior to back-filling trench, survey and record invert and flow line elevations. Survey and record top of curb and flow line elevations on finished surfaces at key locations (such as Back of Curbs, grade breaks, corners or angle points) in sufficient number to demonstrate Work complies with intent of Contract Documents.
- C. Provide horizontal and vertical control for batter boards for drainage, utility, and other on-site structures as required.
 1. Set grades for vaults one inch higher than adjacent surrounding design grades, unless noted otherwise.
- D. Leave all trenches open until required inspection is completed.

3.05 SURVEY REQUIREMENTS FOR STRUCTURES

- A. Furnish building corner offsets as required to adequately locate building pads. Provide cut and fill stakes within building pad perimeter adequate to control both over excavation and re-compaction and final sub-grade elevation of building pad.
- B. Submit a certification signed by surveyor confirming elevations and locations of improvements are in conformance with Contract Documents. Statement shall include survey notes for finish floor and building pad, showing actual measured elevations on completed sub-grade, recorded to nearest 0.01 of a foot. Building pad tolerance will be plus or minus 0.1 of a foot.

END OF SECTION

SECTION 01 74 19
CONSTRUCTION WASTE MANAGEMENT AND DISPOSAL

PART 1 GENERAL

1.01 WASTE MANAGEMENT REQUIREMENTS

- A. Comply with the requirements Section 5.408 of the California Green Building Standards Code.
 - 1. Recycle and/or salvage for reuse a minimum of 65percent of the nonhazardous construction and demolition waste in accordance with Section 504.8.1.1, 5.408.1.2, or 5.408.1.3; or meet a local construction and demolition waste management ordinance, whichever is more stringent.
- B. District requires that this project generate the least amount of trash and waste possible.
- C. Employ processes that ensure the generation of as little waste as possible due to error, poor planning, breakage, mishandling, contamination, or other factors.
- D. Minimize trash/waste disposal in landfills; reuse, salvage, or recycle as much waste as economically feasible.
- E. Required Recycling, Salvage, and Reuse: The following may not be disposed of in landfills or by incineration:
 - 1. Aluminum and plastic beverage containers.
 - 2. Corrugated cardboard.
 - 3. Wood pallets.
 - 4. Clean dimensional wood.
 - 5. Concrete: May be crushed and used as riprap, aggregate, sub-base material, or fill.
 - 6. Bricks: May be used on project if whole, or crushed and used as landscape cover, sub-base material, or fill.
 - 7. Concrete masonry units: May be used on project if whole, or crushed and used as sub-base material or fill.
 - 8. Asphalt paving: May be recycled into paving for project.
 - 9. Metals, including packaging banding, metal studs, sheet metal, structural steel, piping, reinforcing bars, door frames, and other items made of steel, iron, galvanized steel, stainless steel, aluminum, copper, zinc, lead, brass, and bronze.
 - 10. Glass.
 - 11. Gypsum drywall and plaster.
 - 12. Carpet, carpet cushion, carpet tile, and carpet remnants, both new and removed: DuPont (<http://flooring.dupont.com>) and Interface (www.interfaceinc.com) conduct reclamation programs.
 - 13. Roofing.
 - 14. Paint.
 - 15. Plastic sheeting.
 - 16. Rigid foam insulation.

17. Windows, doors, and door hardware.
18. Plumbing fixtures.
19. Mechanical and electrical equipment.
20. Fluorescent lamps (light bulbs).
21. Acoustical ceiling tile and panels.
22. Materials which could be hazardous and subject to special disposal regulations include but are not limited to the following: CalGreen Section 5.408.2
 - a. Lead-Based Paint
 - b. Asbestos: Found in older pipe insulation, asphalt floor tiles, linoleum, insulation, etc.
 - c. Polychlorinated Biphenyls (PCBs):
 - 1) Found in electrical oil filled equipment manufactured prior to 1978 such as transformers, switches and fluorescent lamp ballasts.
 - 2) Also found in adhesive, sealant, caulk, glazing putty, roofing material, pesticide vehicle, ink, paper, fabric dye, gaskets, and hydraulic fluid.
 - d. HVAC Refrigerants: Containing Fluorinated and Chlorinated compounds.
 - e. Drinking Fountain Refrigerants: Containing Fluorinated and Chlorinated compounds.
 - f. Fluorescent Light Tubes: Contain mercury.
 - g. EXIT signs and Smoke Detectors: May contain unregulated, radioactive tritium. Required to be returned to manufacturer.
 - h. Contaminated Soils.
 - i. Pressure Treated Lumber.
- F. Contractor shall submit periodic Waste Disposal Reports; all landfill disposal, recycling, salvage, and reuse must be reported regardless of to whom the cost or savings accrues; use the same units of measure on all reports.
 1. Contractor's quantitative reports for construction waste materials as a condition of approval of progress payments.
- G. Contractor shall develop and follow a Waste Management Plan designed to implement these requirements. CalGreen Section 5.408.1.1.
- H. The following sources may be useful in developing the Waste Management Plan:
 1. California Recycling Department, at www.bsc.ca.gov/Home/CALGreen.aspx.
 2. General information contacts regarding construction and demolition waste:
 - a. EPA Construction and demolition (C&D) debris website: www.epa.gov/epawaste/conserves/imr/cdm/.
 - b. Directory of Wood-Framed Building Deconstruction and Reused Building Materials Companies: www.fpl.fs.fed.us/documnts/fplgtr/fpl_gtr150.pdf.
 - c. Additional resources to be developed by Contractor with assistance from District and Contractor, as requested.
 3. Recycling Haulers and Markets: The source list below contains local haulers and markets for recyclable materials. This list is provided for information only and is not necessarily comprehensive; other haulers and markets are acceptable.
 - a. CAL-MAX: www.calrecycle.ca.gov/calmax/.

- 1) A free service designed to help businesses find markets for non-hazardous materials they have traditionally discarded.
- b. General Recycling/Reuse Centers: For information on qualified local solid waste haulers contact the California Department of Resources Recycling and Recovery - CalRecycle. The website lists wastes recycling facilities in counties throughout the State of California.
 - 1) <http://www.calrecycle.ca.gov/default.asp>
- I. Methods of trash/waste disposal that are not acceptable are:
 1. Burning on the project site.
 2. Burying on the project site.
 3. Dumping or burying on other property, public or private.
 4. Other illegal dumping or burying.
 5. Incineration, either on- or off-site.
- J. Regulatory Requirements: Contractor is responsible for knowing and complying with regulatory requirements, including but not limited to Federal, state and local requirements, pertaining to legal disposal of all construction and demolition waste materials.

1.02 RELATED REQUIREMENTS

- A. Section 01 30 00 - Administrative Requirements: Additional requirements for project meetings, reports, submittal procedures, and project documentation.
- B. Section 01 50 00 - Temporary Facilities and Controls: Additional requirements related to trash/waste collection and removal facilities and services.
- C. Section 01 60 00 - Product Requirements: Waste prevention requirements related to delivery, storage, and handling.
- D. Section 01 70 00 - Execution and Closeout Requirements: Trash/waste prevention procedures related to demolition, cutting and patching, installation, protection, and cleaning.

1.03 DEFINITIONS

- A. Clean: Untreated and unpainted; not contaminated with oils, solvents, caulk, or the like.
- B. Construction and Demolition Waste: Solid wastes typically including building materials, packaging, trash, debris, and rubble resulting from construction, remodeling, repair and demolition operations.
 1. Debris that is not hazardous as defined in CalGreen Section 5.408.2 and California Code of Regulations, Title 22, Section 66261.3 et seq.
 2. This term includes, but is not limited to, asphalt concrete, Portland cement concrete, brick, lumber, gypsum wallboard, cardboard and other associated packaging, roofing material, ceramic tile, carpeting, plastic pipe, and steel.
 3. The debris may be commingled with rock, soil, tree stumps, and other vegetative matter resulting from land clearing and landscaping for construction or land development projects.
- C. Disposal: Removal off-site of demolition and construction waste and subsequent sale, recycling, reuse, or deposit in landfill or incinerator acceptable to authorities having jurisdiction.

- D. Diversion: Avoidance of demolition and construction waste sent to landfill or incineration. Diversion does not include using materials for landfill, alternate daily cover on landfills, or materials used as fuel in waste-to-energy processes.
- E. Enforcement Agency (EA). Enforcement agency as defined in CA Public Resources Code 40130.
- F. Hazardous: Exhibiting the characteristics of hazardous substances, i.e., ignitibility, corrosivity, toxicity or reactivity.
- G. Landfill, Inert waste or Inert Disposal Facility:
 - 1. A disposal facility that accepts only inert waste such as soil and rock, fully cured asphalt paving, uncontaminated concrete (including fiberglass or steel reinforcing rods embedded in the concrete), brick, glass, and ceramics, for land disposal.
- H. Landfill, Class III:
 - 1. A landfill that accepts non-hazardous resources such as household, commercial, and industrial waste, resulting from construction, remodeling, repair, and demolition operations.
 - 2. A Class III landfill must have a solid waste facilities permit from the California Integrated Waste Management Board (CIWMB) and is regulated by the Enforcement Agency (EA).
- I. Mixed Debris: Loads that include commingled recyclable and non-recyclable materials generated at the construction site.
- J. Mixed Debris Recycling Facility: A processing facility that accepts loads of commingled construction and demolition debris for the purpose of recovering re-usable and recyclable materials and disposing the non-recyclable residual materials.
- K. Nonhazardous: Exhibiting none of the characteristics of hazardous substances, i.e., ignitibility, corrosivity, toxicity, or reactivity.
- L. Nontoxic: Neither immediately poisonous to humans nor poisonous after a long period of exposure.
- M. Recyclable: The ability of a product or material to be recovered at the end of its life cycle and remanufactured into a new product for reuse by others.
- N. Recycle: To remove a waste material from the project site to another site for remanufacture into a new product for reuse by others.
- O. Recycling: The process of sorting, cleansing, treating and reconstituting solid waste and other discarded materials for the purpose of using the altered form. Recycling does not include burning, incinerating, or thermally destroying waste.
- P. Recycling Center: A facility that receives only C&D material that has been separated for reuse prior to receipt, in which the residual (disposed) amount of waste in the material is less than 10% of the amount separated for reuse by weight.
- Q. Return: To give back reusable items or unused products to vendors for credit.
- R. Reuse: To reuse a construction waste material in some manner on the project site.
- S. Salvage: To remove a waste material from the project site to another site for resale or reuse by others.
- T. Sediment: Soil and other debris that has been eroded and transported by storm or well production run-off water.

- U. Separated for Reuse:
 1. Materials, including commingled recyclables.
 2. Separated or kept separate from the solid waste stream for the purpose of:
 - a. Additional sorting or processing those materials for reuse or recycling.
 - 1) In order to return them to the economic mainstream in the form of raw material for new, reused, or reconstituted products.
 - b. Products shall meet the quality standards necessary to be used in the marketplace.
 - c. Includes materials that have been "source separated".
- V. Solid Waste:
 1. All putrescible and nonputrescible solid, semisolid, and liquid wastes, including:
 - a. Garbage, trash, refuse, paper, rubbish, ashes, industrial wastes, demolition and construction wastes.
 - b. Abandoned vehicles and parts thereof.
 - c. Discarded home and industrial appliances.
 - d. Dewatered, treated, or chemically fixed sewage sludge which is not hazardous waste.
 - e. Manure, vegetable or animal solid and semisolid wastes.
 - f. Other discarded solid and semisolid wastes.
 2. "Solid waste" does not include hazardous waste, radioactive waste, or medical waste as defined or regulated by State law.
- W. Source Separation: The act of keeping different types of waste materials separate beginning from the first time they become waste.
 1. Materials, including commingled recyclables, that have been separated or kept separate from the solid waste stream at the point of generation, for the purpose of additional sorting or processing of those materials for reuse or recycling in order to return them to the economic mainstream in the form of raw materials for new, reused, or reconstituted products which meet the quality standards necessary to be used in the marketplace.
- X. Toxic: Poisonous to humans either immediately or after a long period of exposure.
- Y. Trash: Any product or material unable to be reused, returned, recycled, or salvaged.
- Z. Waste: Extra material or material that has reached the end of its useful life in its intended use. Waste includes salvageable, returnable, recyclable, and reusable material.
- AA. Waste Hauler: A company that possesses a valid permit from the local waste management authority to collect and transport solid wastes from individuals or businesses for the purpose of recycling or disposal in the locality.

1.04 SUBMITTALS

- A. See Section 01 30 00 - Administrative Requirements, for submittal procedures.
- B. Submit Waste Management Plan within 30 calendar days after receipt of Notice to Proceed, or prior to any trash or waste removal, whichever occurs sooner; submit projection of all trash and waste that will require disposal and alternatives to landfilling.
 1. Submit four copies of CWMP for review.

- a. Contractor's Construction Waste and Recycling Plan must be approved by the Architect and Construction Manager prior to the start of Work.
 2. Approval of the Contractor's CWMP shall not relieve the Contractor of responsibility for adequate and continuing control of pollutants and other environmental protection measures.
- C. Waste Management Plan: Include the following information:
1. Analysis of the trash and waste projected to be generated during the entire project construction cycle, including types and quantities.
 2. Landfill Options: The name, address, and telephone number of the landfill(s) where trash/waste will be disposed of, the applicable landfill tipping fee(s), and the projected cost of disposing of all project trash/waste in the landfill(s).
 3. Landfill Alternatives: List all waste materials that will be diverted from landfills by reuse, salvage, or recycling.
 - a. List each material proposed to be salvaged, reused, or recycled.
 - b. List the local market for each material.
 4. Meetings: Describe regular meetings to be held to address waste prevention, reduction, recycling, salvage, reuse, and disposal.
 5. Materials Handling Procedures: Describe the means by which materials to be diverted from landfills will be protected from contamination and prepared for acceptance by designated facilities; include separation procedures for recyclables, storage, and packaging.
 6. Transportation: Identify the destination and means of transportation of materials to be recycled; i.e. whether materials will be site-separated and self-hauled to designated centers, or whether mixed materials will be collected by a waste hauler.
 7. Recycling Incentives: Describe procedures required to obtain credits, rebates, or similar incentives.
- D. Waste Disposal Reports: Submit at specified intervals, with details of quantities of trash and waste, means of disposal or reuse, and costs; show both totals to date and since last report.
1. Submit updated Report with each Application for Progress Payment; failure to submit Report will delay payment.
 - a. Inert materials shall achieve a construction waste diversion rate of at least 95 percent.
 - 1) These materials include, but are not limited to, concrete, asphalt and rock.
 - 2) Earthwork is not included.
 - 3) Excavated soil shall not be included in any of the calculations used to ensure compliance with this specification section.
 - b. The overall diversion rate must be based on weight.
 - c. The diversion rate of individual materials can be measured in either weight or volume, but the rate shall be converted into the units selected for calculating the overall diversion rate.
 - 1) All individual material diversions must be converted to a consistent set of units when calculating the overall diversion rate for the all reports and submittals required for the Work.

- d. Conversion rate numbers shall be based on standard conversion rate data for construction projects provided by the California Integrated Waste Management Board (CIWMB). This data is available at the following internet location, <https://www.calrecycle.ca.gov/LGCentral/Library/Guidance/>.
2. Submit Report on a form acceptable to District.
3. Landfill Disposal: Include the following information:
 - a. Identification of material.
 - b. Amount, in tons or cubic yards, of trash/waste material from the project disposed of in landfills.
 - c. State the identity of landfills, total amount of tipping fees paid to landfill, and total disposal cost.
 - d. Include manifests, weight tickets, receipts, and invoices as evidence of quantity and cost.
4. Recycled and Salvaged Materials: Include the following information for each:
 - a. Identification of material, including those retrieved by installer for use on other projects.
 - b. Amount, in tons or cubic yards, date removed from the project site, and receiving party.
 - c. Transportation cost, amount paid or received for the material, and the net total cost or savings of salvage or recycling each material.
 - d. Include manifests, weight tickets, receipts, and invoices as evidence of quantity and cost.
 - e. Certification by receiving party that materials will not be disposed of in landfills or by incineration.
5. Material Reused on Project: Include the following information for each:
 - a. Identification of material and how it was used in the project.
 - b. Amount, in tons or cubic yards.
 - c. Include weight tickets as evidence of quantity.
6. Other Disposal Methods: Include information similar to that described above, as appropriate to disposal method.

PART 2 PRODUCTS

2.01 PRODUCT SUBSTITUTIONS

- A. See Section 01 60 00 - Product Requirements for substitution submission procedures.
- B. For each proposed product substitution, submit the following information in addition to requirements specified in Section 01 60 00:
 1. Relative amount of waste produced, compared to specified product.
 2. Cost savings on waste disposal, compared to specified product, to be deducted from the Contract Sum.
 3. Proposed disposal method for waste product.
 4. Markets for recycled waste product.

PART 3 EXECUTION

3.01 WASTE MANAGEMENT PROCEDURES

- A. See Section 01 30 00 for additional requirements for project meetings, reports, submittal procedures, and project documentation.
- B. See Section 01 50 00 for additional requirements related to trash/waste collection and removal facilities and services.
- C. See Section 01 60 00 for waste prevention requirements related to delivery, storage, and handling.
- D. See Section 01 70 00 for trash/waste prevention procedures related to demolition, cutting and patching, installation, protection, and cleaning.

3.02 WASTE MANAGEMENT PLAN IMPLEMENTATION

- A. Manager: Designate an on-site person or persons responsible for instructing workers and overseeing and documenting results of the Waste Management Plan.
- B. Communication: Distribute copies of the Waste Management Plan to job site foreman, each subcontractor, District, and Architect.
- C. Instruction: Provide on-site instruction of appropriate separation, handling, and recycling, salvage, reuse, and return methods to be used by all parties at the appropriate stages of the project.
- D. Meetings: Discuss trash/waste management goals and issues at project meetings.
 - 1. Prebid meeting.
 - 2. Preconstruction meeting.
 - 3. Regular job-site meetings.
- E. Facilities: Provide specific facilities for separation and storage of materials for recycling, salvage, reuse, return, and trash disposal, for use by all contractors and installers.
 - 1. As a minimum, provide:
 - a. Separate area for storage of materials to be reused on-site, such as wood cut-offs for blocking.
 - b. Separate dumpsters for each category of recyclable.
 - c. Recycling bins at worker lunch area.
 - 2. Provide containers as required.
 - 3. Provide temporary enclosures around piles of separated materials to be recycled or salvaged.
 - 4. Provide materials for barriers and enclosures that are nonhazardous, recyclable, or reusable to the maximum extent possible; reuse project construction waste materials if possible.
 - 5. Locate enclosures out of the way of construction traffic.
 - 6. Provide adequate space for pick-up and delivery and convenience to subcontractors.
 - 7. If an enclosed area is not provided, clearly lay out and label a specific area on-site.

- 8. Keep recycling and trash/waste bin areas neat and clean and clearly marked in order to avoid contamination of materials.
- F. Hazardous Wastes: Separate, store, and dispose of hazardous wastes according to applicable regulations.
- G. Recycling: Separate, store, protect, and handle at the site identified recyclable waste products in order to prevent contamination of materials and to maximize recyclability of identified materials. Arrange for timely pickups from the site or deliveries to recycling facility in order to prevent contamination of recyclable materials.
- H. Reuse of Materials On-Site: Set aside, sort, and protect separated products in preparation for reuse.
- I. Salvage: Set aside, sort, and protect products to be salvaged for reuse off-site.

3.03 DISPOSAL OPERATIONS AND WASTE HAULING

- A. Remove waste materials from Project Site and legally dispose of them in a landfill or incinerator acceptable to authorities having jurisdiction.
 - 1. Except for items or materials to be salvaged, recycled, or otherwise reused.
 - 2. Except as otherwise specified, do not allow waste materials that are to be disposed of to accumulate on site.
 - 3. Use a permitted waste hauler or Contractor's trucking services and personnel. To confirm valid permitted status of waste haulers, contact the local solid waste authority.
 - 4. Become familiar with the conditions for acceptance of new construction, excavation and demolition materials at recycling facilities, prior to delivering materials.
 - 5. Deliver to facilities that can legally accept new construction, excavation and demolition materials for purpose of re-use, recycling, composting, or disposal.
 - 6. Remove and transport debris in a manner that will prevent spillage on adjacent surfaces and areas.
 - 7. Do not burn or bury waste materials on or off site. Appropriate on-site topical application of ground gypsum or wood, or use of site paving as granulated fill is considered reuse, not waste.

3.04 PLAN AND REPORT FORMS

- A. See suggested forms on the following pages.

END OF SECTION

CONTRACTOR'S CONSTRUCTION WASTE AND RECYCLING PLAN

(Submit After Award of Contract and Prior to Start of Work)

Project Title:						
Contract or Work Order No.:						
Contractor's Name:						
Street Address:						
City:			State:		Zip:	
Phone: ()			Fax: ()			
E-Mail Address:						
Prepared by: (Print Name)						
Date Submitted:						
Date Submitted:						
Project Period:						
Project Period:		From:				TO:
Reuse, Recycling or Disposal Processes To Be Used						
Describe the types of recycling processes or disposal activities that will be used for material generated in the project. Indicate the type of process or activity by number, types of materials, and estimated quantities that will be recycled or disposed in the sections below:						
01 - Reuse of building materials or salvage items on site (i.e. crushed base or red clay brick)						
02 - Salvaging building materials or salvage items at an offsite salvage or re-use center (i.e. lighting, fixtures)						
03 - Recycling source separated materials on site (i.e. crushing asphalt/concrete for reuse or grinding for mulch)						
04 - Recycling source separated materials at an offsite recycling center (i.e. scrap metal or green materials)						
05 - Recycling commingled loads of C&D materials at an offsite mixed debris recycling center or transfer station						
06 - Recycling material as Alternative Daily Cover at landfills						
07 - Delivery of soils or mixed inerts to an inert landfill for disposal (inert fill).						
08 - Disposal at a landfill or transfer station.						
09 - Other (please describe) _____						
Types of Material To Be Generated						
Use these codes to indicate the types of material that will be generated on the project						
A = Asphalt C = Concrete M = Metals I = Mixed Inert G = Green Materials						
D = Drywall P/C=Paper/Cardboard W/C = Wire/Cable S= Soils (Non Hazardous)						
M/C = Miscellaneous Construction Debris R = Reuse/Salvage W = Wood O = Other (describe)						
Facilities Used: Provide Name of Facility and Location (City)						
Total Truck Loads: Provide Number of Trucks Hauled from Site During Reporting Period						
Total Quantities: If scales are available at sites, report in tons. If not, quantify by cubic yards. For salvage/reuse items, quantify by estimated weight (or units).						
SECTION I - RE-USED/RECYCLED MATERIALS						
Include all recycling activities for source separated or mixed material recycling centers where recycling will occur.						
Type of Material	Type of Activity	Facility to be Used/Location	Total Truck Loads	Total Quantities		
				Tons	Cubic YD	Other Wt.
(ex.) M	04	ABC Metals, Los Angeles	24	355		
a. Total Diversion						

CONTRACTOR'S CONSTRUCTION WASTE AND RECYCLING PLAN

Continued

SECTION II - DISPOSED MATERIALS						
Include all disposal activities for landfills, transfer stations, or inert landfills where no recycling will occur.						
Type of Material	Type of Activity	Facility to be Used/Location	Total Truck Loads	Total Quantities		
				Tons	Cubic YD	Other Wt.
(ex.) D	08	DEF Landfill, Los Angeles	2	35		
b. Total Disposal				0	0	0

SECTION III - TOTAL MATERIALS GENERATED			
This section calculates the total materials to be generated during the project period (Reuse/Recycle + Disposal = Generation)			
	Tons	Cubic YD	Other Wt.
a. Total Reused/Recycled	0	0	0
b. Total Disposed	0	0	0
c. Total Generated	0	0	0

SECTION IV - CONTRACTOR'S LANDFILL DIVERSION RATE CALCULATION			
Add totals from Section I + Section II			
	Tons	Cubic YD	Other Wt.
a. Materials Re-Used and Recycled	0		
b. Materials Disposed	0		
c. Total Materials Generated (a. + b. = c.)	0	0	0
d. Landfill Diversion Rate (Tonnage Only)*			

* Use tons only to calculate recycling percentages: Tons Reused/Recycled/Tons Generated = % Recycled

Contractor's Comments (Provide any additional information pertinent to planned reuse, recycling, or disposal activities):

- Notes:
- | | |
|--|--|
| 1. Suggested Conversion Factors: From Cubic Yards to Tons
(Use when scales are not available) | c. Ferrous Metals: .22 (ex. 1000 CY Ferrous Metal = 220 tons) |
| a. Asphalt: .61 (ex. 1000 CY Asphalt = 610 tons. Applies to broken chunks of asphalt) | d. Non-Ferrous Metals: .10 (ex. 1000 CY Non-Ferrous Metals = 100 tons) |
| b. Concrete: .93 (ex. 1000 CY Concrete = 930 tons. Applies to broken chunks of concrete) | e. Drywall Scrap: .20 |
| | f. Wood Scrap: .16 |

CONTRACTOR'S REUSE, RECYCLING, AND DISPOSAL REPORT

(Submit With Each Progress Payment)

Project Title:						
Contract or Work Order No.:						
Contractor's Name:						
Street Address:						
City:			State:		Zip:	
Phone: ()			Fax: ()			
E-Mail Address:						
Prepared by: (Print Name)						
Date Submitted:						
Project Period:		From:			TO:	
Reuse, Recycling or Disposal Processes to Be Used						
Describe the types of recycling processes or disposal activities that will be used for material generated in the project. Indicate the type of process or activity by number, types of materials, and estimated quantities that will be recycled or disposed in the sections below:						
01 - Reuse of building materials or salvage items on site (i.e. crushed base or red clay brick)						
02 - Salvaging building materials or salvage items at an offsite salvage or re-use center (i.e. lighting, fixtures)						
03 - Recycling source separated materials on site (i.e. crushing asphalt/concrete for reuse or grinding for mulch)						
04 - Recycling source separated materials at an offsite recycling center (i.e. scrap metal or green materials)						
05 - Recycling commingled loads of C&D materials at an offsite mixed debris recycling center or transfer station						
06 - Recycling material as Alternative Daily Cover at landfills						
07 - Delivery of soils or mixed inerts to an inert landfill for disposal (inert fill).						
08 - Disposal at a landfill or transfer station.						
09 - Other (please describe) _____						
Types of Material To Be Generated						
Use these codes to indicate the types of material that will be generated on the project						
A = Asphalt		C = Concrete		M = Metals		I = Mixed Inert
D = Drywall		P/C=Paper/Cardboard		W/C = Wire/Cable		S= Soils (Non-Hazardous)
M/C = Miscellaneous Construction Debris		R = Reuse/Salvage		W = Wood		O = Other (describe)
Facilities Used: Provide Name of Facility and Location (City)						
Total Truck Loads: Provide Number of Trucks Hauled from Site During Reporting Period						
Total Quantities: If scales are available at sites, report in tons. If not, quantify by cubic yards. For salvage/reuse items, quantify by estimated weight (or units).						
SECTION I - RE-USED/RECYCLED MATERIALS						
Include all recycling activities for source separated or mixed material recycling centers where recycling will occur.						
Type of Material	Type of Activity	Facility to be Used/Location	Total Truck Loads	Total Quantities		
				Tons	Cubic YD	Other Wt.
(ex.) M	04	ABC Metals, Los Angeles	24	355		
a. Total Diversion						

CONTRACTOR'S REUSE, RECYCLING, AND DISPOSAL REPORT

Continued

SECTION II - DISPOSED MATERIALS						
Include all disposal activities for landfills, transfer stations, or inert landfills where no recycling will occur.						
Type of Material	Type of Activity	Facility to be Used/Location	Total Truck Loads	Total Quantities		
				Tons	Cubic YD	Other Wt.
(ex.) D	08	DEF Landfill, Los Angeles	2	35		
b. Total Disposal						

SECTION III - TOTAL MATERIALS GENERATED			
This section calculates the total materials to be generated during the project period (Reuse/Recycle + Disposal = Generation)			
	Tons	Cubic YD	Other Wt.
a. Total Reused/Recycled			
b. Total Disposed			
c. Total Generated			

SECTION IV - CONTRACTOR'S LANDFILL DIVERSION RATE CALCULATION			
Add totals from Section I + Section II			
	Tons	Cubic YD	Other Wt.
a. Materials Re-Used and Recycled			
b. Materials Disposed			
c. Total Materials Generated (a. + b. = c.)			
d. Landfill Diversion Rate (Tonnage Only)*			

* Use tons only to calculate recycling percentages: Tons Reused/Recycled/Tons Generated = % Recycled

Contractor's Comments (Provide any additional information pertinent to planned reuse, recycling, or disposal activities):

- Notes:
- | | |
|--|--|
| 1. Suggested Conversion Factors: From Cubic Yards to Tons
(Use when scales are not available) | c. Ferrous Metals: .22 (ex. 1000 CY Ferrous Metal = 220 tons) |
| a. Asphalt: .61 (ex. 1000 CY Asphalt = 610 tons. Applies to broken chunks of asphalt) | d. Non-Ferrous Metals: .10 (ex. 1000 CY Non-Ferrous Metals = 100 tons) |
| b. Concrete: .93 (ex. 1000 CY Concrete = 930 tons. Applies to broken chunks of concrete) | e. Drywall Scrap: .20 |
| | f. Wood Scrap: .16 |

SECTION 01 78 00
CLOSEOUT SUBMITTALS

PART 1 GENERAL

1.01 SECTION INCLUDES

- A. Project record documents.
- B. Operation and maintenance data.
- C. Warranties and bonds.

1.02 RELATED REQUIREMENTS

- A. Owner issued Bidding Instructions and General Conditions: Performance bond and labor and material payment bonds, warranty, and correction of work.
- B. Section 01 30 00 - Administrative Requirements: Submittals procedures, shop drawings, product data, and samples.
- C. Section 01 45 33 - Code-Required Special Inspections: Construction oversight procedures by DSA regarding the execution, approval, and closeout of this building project.
- D. Section 01 70 00 - Execution and Closeout Requirements: Contract closeout procedures.
- E. Individual Product Sections: Specific requirements for operation and maintenance data.
- F. Individual Product Sections: Warranties required for specific products or Work.
 - 1. Special Project warranty requirements for specific products or elements of the Work; commitments and agreements for continuing services to District.

1.03 DEFINITIONS

- A. Warranty: Assurance to District by Contractor, installer, supplier, manufacturer or other party responsible as warrantor, for the quantity, quality, performance and other representations of a product, system service of the Work, in whole or in part, for the duration of the specified period of time.
- B. Guarantee: Assurance to District by Contractor or product manufacturer or other specified party, as guarantor, that the specified warranty will be fulfilled by the guarantor in the event of default by the warrantor.
- C. Standard Product Warranty: Preprinted, written warranty published by product manufacturer for particular products and specifically endorsed by the manufacturer to the District.
- D. Special Project Warranty: Written warranty required by or incorporated into Contract Documents, to extend time limits provided by standard warranty or to provide greater rights for District.
- E. Correction Period: As defined in the Conditions of the Contract, Correction Period shall be synonymous with "warranty period", "guarantee period" and similar terms used in the Contract Specifications.

1.04 SUBMITTALS

- A. Advance Submittals: For equipment and systems, or component parts of systems, put into service during construction and operated by District, submit documents within ten days of start of operation by District.
- B. Final Completion Submittals: Prior to application for final payment, Contractor shall submit 3 copies the following:
 - 1. Agency Document Submittals: Submit to District all documents required by authorities having jurisdiction, including serving utilities and other agencies. Submit original versions of all permit cards, with final sign-off by inspectors. Submit all certifications of inspections and tests.
 - a. Contractor shall also complete all required contractor forms and obtain DSA approval of these same forms. Comply with "Final Certification of Construction" per Title 24 Part 1 section 4-339.
 - 1) Form-6.C: Verified Report – Contractor: From each Contractor having a contract with the District.
 - 2. Final Specifications Submittals: Submit to District all documents and products required by Specifications to be submitted, including the following:
 - a. Project record drawings and specifications.
 - b. Operating and maintenance data.
 - c. Guarantees, warranties and bonds.
 - d. Keys and keying schedule.
 - e. Spare parts and extra stock.
 - f. Test reports and certificates of compliance.
 - 3. Certificates of Compliance and Test Report Submittals: Submit to District certificates and reports as specified and as required by authorities having jurisdiction, including the following:
 - a. Sterilization of water systems.
 - b. Sanitary sewer system tests.
 - c. Gas system tests.
 - d. Lighting, power and signal system tests.
 - e. Ventilation equipment and air balance tests.
 - f. Fire sprinkler system tests.
 - g. Fire detection system, smoke alarms and dampers.
 - h. Roofing inspections and tests.
 - 4. Lien and Bonding Company Releases: Submit to District, with copy to Architect, evidence of satisfaction of encumbrances on Project by completion and submission of The American Institute of Architects Forms:
 - a. G706 - Contractor's Affidavit of Payment of Debts and Claims;
 - b. G706A - Contractor's Affidavit of Release of Liens;
 - c. (if applicable) G707 - Consent of Surety;
 - d. or forms as as agreed to by the District.
 - e. Comply also with other requirements of District, as directed.

- f. All signatures shall be notarized.
- 5. Subcontractor List: Submit two copies to District and two copies to Architect of updated Subcontractor and Materials Supplier List.
- 6. Warranty Documents: Prepare and submit to District all warranties and bonds as specified in Contract General Conditions and this Section.
- C. Project Record Documents: Submit documents to Architect with claim for final Application for Payment.
- D. Operation and Maintenance Data:
 - 1. Submit two copies of preliminary draft or proposed formats and outlines of contents before start of Work. Architect will review draft and return one copy with comments.
 - 2. For equipment, or component parts of equipment put into service during construction and operated by District, submit completed documents within ten days after acceptance.
 - 3. Submit one copy of completed documents 15 days prior to final inspection. This copy will be reviewed and returned after final inspection, with Architect comments. Revise content of all document sets as required prior to final submission.
 - 4. Submit two sets of revised final documents in final form within 10 days after final inspection.
- E. Warranties and Bonds:
 - 1. For equipment or component parts of equipment put into service during construction with District's permission, submit documents within 10 days after acceptance.
 - 2. Make other submittals within 10 days after Date of Substantial Completion, prior to final Application for Payment.
 - 3. For items of Work for which acceptance is delayed beyond Date of Substantial Completion, submit within 10 days after acceptance, listing the date of acceptance as the beginning of the warranty period.

1.05 WARRANTIES AND GUARANTEES

- A. General:
 - 1. Provide all warranties and guarantees with District named as beneficiary.
 - 2. For equipment and products, or components thereof, bearing a manufacturer's warranty or guarantee that extends for a period of time beyond the Contractor's warranty and guarantee, so state in the warranty or guarantee.
- B. Provisions for Special Warranties: Refer to Conditions of the Contract for terms of the Contractor's special warranty of workmanship and materials.
- C. General Warranty and Guarantee Requirements:
 - 1. Warranty shall be an agreement to repair or replace, without cost and undue hardship to District, Work performed under the Contract which is found to be defective during the Correction Period (warranty or guarantee) period.
 - 2. Repairs and replacements due to improper maintenance or operation, or due to normal wear, usage and weathering are excluded from warranty requirements unless otherwise specified.

- D. Specific Warranty and Guarantee Requirements: Specific requirements are included in product Specifications Sections of Divisions 03 through 33, including content and limitations.
- E. Disclaimers and Limitations:
 - 1. Manufacturer's disclaimers and limitations on product warranties and guarantees shall not relieve Contractor of responsibility for warranty and guarantee requirements.
 - 2. This applies to the Work that incorporates such products, nor shall they relieve suppliers, manufacturers, and installers required to countersign special warranties with Contractor.
- F. Related Damages and Losses: When correcting warranted Work that has been found defective, remove and replace other Work that has been damaged as a result of such defect or that must be removed and replaced to provide access for correction of warranted Work.
- G. Reinstatement of Warranty:
 - 1. When Work covered by a warranty has been found defective and has been corrected by replacement or rebuilding, reinstate the warranty by written endorsement.
 - 2. The reinstated warranty shall be equal to the original warranty with an equitable adjustment for depreciation.
- H. Replacement Cost:
 - 1. Upon determination that Work covered by a warranty has been found to be defective, replace or reconstruct the Work to a condition acceptable to District, complying with applicable requirements of the Contract Documents.
 - 2. Contractor shall be responsible for all costs for replacing or reconstructing defective Work regardless of whether District has benefited from use of the Work through a portion of its anticipated useful service life.
- I. District's Recourse:
 - 1. Written warranties made to the District shall be in addition to implied warranties, and shall not limit the duties, obligations, rights and remedies otherwise available under law, nor shall warranty periods be interpreted as limitations on time in which the District can enforce such other duties, obligations, rights, or remedies.
 - 2. Rejection of Warranties:
 - a. The District reserves the right to reject warranties and to limit selections to products with warranties not in conflict with requirements of the Contract Documents.
- J. Warranty as Condition of Acceptance:
 - 1. District reserves the right to refuse to accept Work for the Project where a special warranty, certification, or similar commitment shall be required on such Work or part of the Work, until evidence is presented that entities required to countersign such commitments are willing to do so.

PART 2 PRODUCTS - NOT USED

PART 3 EXECUTION

3.01 PROJECT RECORD DOCUMENTS

- A. Record Documents are to be maintained and submitted in searchable live electronic format (PDF).
 - 1. Develop in compliance with Section 01 30 00 - Administrative Requirements.
 - 2. Acceptable markup software:
 - a. Adobe Acrobat Professional.
 - b. Bluebeam Revu.
- B. Maintain on site one set of the following record documents; record actual revisions to the Work:
 - 1. Contract Drawings.
 - 2. Project Manual with Specifications.
 - 3. Addenda.
 - 4. Change Orders and other modifications to the Contract.
 - 5. Reviewed shop drawings, product data, and samples.
 - 6. Manufacturer's instruction for assembly, installation, and adjusting.
- C. Ensure entries are complete and accurate, enabling future reference by District.
- D. Store record documents separate from documents used for construction.
- E. Record information concurrent with construction progress.
- F. Specifications: Legibly mark and record at each product section description of actual products installed, including the following:
 - 1. Manufacturer's name and product model and number.
 - 2. Product substitutions or alternates utilized.
 - 3. Changes made by Addenda and modifications.
 - 4. Provide copies of all approved addenda, directives, corrections, and change orders affecting the associated project.
 - a. These copies shall be included with the "Bid Set" and/or "Record Set" listed above and formatted as detailed above.
- G. Record Drawings and Shop Drawings: Legibly mark each item to record actual construction including:
 - 1. Reproducible set of Contract Drawings will be provided to Contractor by District through Architect or Construction Manager.
 - 2. Measured depths of foundations in relation to finish first floor datum.
 - 3. Measured horizontal and vertical locations of underground utilities and appurtenances, referenced to permanent surface improvements.

4. Measured locations of internal utilities and appurtenances concealed in construction, referenced to visible and accessible features of the Work.
5. Field changes of dimension and detail.
6. Details not on original Contract drawings.
 - a. Application of copies of details produced and provided by Architect during construction will be accepted.
- H. Submission: Submit Record Documents in searchable (live text and redlines mark-ups; not scanned) PDF format to Architect prior to final Application for Payment.
 1. Maintain one additional paper copy and one in PDF format (on CD) of the fire suppression and fire protection detection system drawings and specifications at the building premises.
 - a. One copy is to be kept on site for a period of three years to comply with CFC section 901.6.2.

3.02 OPERATION AND MAINTENANCE DATA

- A. Source Data: For each product or system, list names, addresses and telephone numbers of Subcontractors and suppliers, including local source of supplies and replacement parts.
- B. Product Data: Mark each sheet to clearly identify specific products and component parts, and data applicable to installation. Delete inapplicable information.
- C. Drawings: Supplement product data to illustrate relations of component parts of equipment and systems, to show control and flow diagrams. Do not use Project Record Documents as maintenance drawings.
- D. Typed Text: As required to supplement product data. Provide logical sequence of instructions for each procedure, incorporating manufacturer's instructions.

3.03 OPERATION AND MAINTENANCE DATA FOR MATERIALS AND FINISHES

- A. For Each Product, Applied Material, and Finish:
 1. Product data, with catalog number, size, composition, and color and texture designations.
 2. Information for re-ordering custom manufactured products.
- B. Instructions for Care and Maintenance: Manufacturer's recommendations for cleaning agents and methods, precautions against detrimental cleaning agents and methods, and recommended schedule for cleaning and maintenance.
- C. Moisture protection and weather-exposed products: Include product data listing applicable reference standards, chemical composition, and details of installation. Provide recommendations for inspections, maintenance, and repair.
- D. Additional information as specified in individual product specification sections.
- E. Where additional instructions are required, beyond the manufacturer's standard printed instructions, have instructions prepared by personnel experienced in the operation and maintenance of the specific products.

3.04 OPERATION AND MAINTENANCE DATA FOR EQUIPMENT AND SYSTEMS

- A. For Each Item of Equipment and Each System:

1. Description of unit or system, and component parts.
 2. Identify function, normal operating characteristics, and limiting conditions.
 3. Include performance curves, with engineering data and tests.
 4. Complete nomenclature and model number of replaceable parts.
- B. Where additional instructions are required, beyond the manufacturer's standard printed instructions, have instructions prepared by personnel experienced in the operation and maintenance of the specific products.
- C. Panelboard Circuit Directories: Provide electrical service characteristics, controls, and communications; typed.
- D. Include color coded wiring diagrams as installed.
- E. Operating Procedures: Include start-up, break-in, and routine normal operating instructions and sequences. Include regulation, control, stopping, shut-down, and emergency instructions. Include summer, winter, and any special operating instructions.
- F. Maintenance Requirements: Include routine procedures and guide for preventative maintenance and trouble shooting; disassembly, repair, and reassembly instructions; and alignment, adjusting, balancing, and checking instructions.
- G. Provide servicing and lubrication schedule, and list of lubricants required.
- H. Include manufacturer's printed operation and maintenance instructions.
- I. Include sequence of operation by controls manufacturer.
- J. Provide original manufacturer's parts list, illustrations, assembly drawings, and diagrams required for maintenance.
- K. Provide control diagrams by controls manufacturer as installed.
- L. Provide Contractor's coordination drawings, with color coded piping diagrams as installed.
- M. Provide charts of valve tag numbers, with location and function of each valve, keyed to flow and control diagrams.
- N. Provide list of original manufacturer's spare parts, current prices, and recommended quantities to be maintained in storage.
1. Parts Data:
 - a. Provide original manufacturer's parts list, illustrations, assembly drawings, and diagrams as necessary for service and maintenance.
 - b. Include complete nomenclature and catalog numbers for consumable and replacement parts.
 - c. Provide list of original manufacturer's spare parts, current prices, and recommended quantities to be maintained in stock by the District or operator.
- O. Include test and balancing reports.
- P. Additional Requirements: As specified in individual product specification sections.

3.05 ASSEMBLY OF OPERATION AND MAINTENANCE MANUALS

- A. Assemble operation and maintenance data into durable manuals for District's personnel use, with data arranged in the same sequence as, and identified by, the specification sections.

1. Provide duplicate electronic formatted (PDF) versions of the O&M binder for record purposes. Organize the same as the printed versions.
- B. Where systems involve more than one specification section, provide separate tabbed divider for each system.
- C. Binders: Commercial quality, 8-1/2 by 11 inch three D side ring binders with durable plastic covers; 2 inch maximum ring size. When multiple binders are used, correlate data into related consistent groupings.
- D. Cover: Identify each binder with typed or printed title OPERATION AND MAINTENANCE INSTRUCTIONS; identify title of Project; identify subject matter of contents.
- E. Project Directory: Title and address of Project; names, addresses, and telephone numbers of Architect, Consultants, Contractor and subcontractors, with names of responsible parties.
- F. Tables of Contents: List every item separated by a divider, using the same identification as on the divider tab; where multiple volumes are required, include all volumes Tables of Contents in each volume, with the current volume clearly identified.
- G. Dividers: Provide tabbed dividers for each separate product and system; identify the contents on the divider tab; immediately following the divider tab include a description of product and major component parts of equipment.
- H. Text: Manufacturer's printed data, or typewritten data on 20 pound paper.
- I. Drawings: Provide with reinforced punched binder tab. Bind in with text; fold larger drawings to size of text pages.
- J. Arrangement of Contents: Organize each volume in parts as follows:
 1. Project Directory.
 2. Table of Contents, of all volumes, and of this volume.
 3. Operation and Maintenance Data: Arranged by system, then by product category.
 - a. Source data.
 - b. Product data, shop drawings, and other submittals.
 - c. Operation and maintenance data.
 - d. Field quality control data.
 - e. Photocopies of warranties and bonds.
 4. Design Data: To allow for addition of design data furnished by Architect or others, provide a tab labeled "Design Data" and provide a binder large enough to allow for insertion of at least 20 pages of typed text.

3.06 WARRANTIES AND BONDS

- A. Obtain warranties and bonds, executed in duplicate by responsible Subcontractors, suppliers, and manufacturers, within 10 days after completion of the applicable item of work. Except for items put into use with District's permission, leave date of beginning of time of warranty until Date of Substantial completion is determined.
- B. Project Warranty and Guarantee Forms:
 1. Example forms for special Project warranties and guarantees are included at the end of this Section.

2. Prepare written documents utilizing the appropriate form, ready for execution by the Contractor, or the Contractor and subcontractor, supplier or manufacturer.
 - a. Submit a draft to District through Architect for approval prior to final execution.
 3. Refer to product technical Sections for specific content requirements, and particular requirements for submittal of special warranties.
 4. Prepare standard warranties and guarantees, excepting manufacturers' standard printed warranties and guarantees, on Contractor's, subcontractor's, material supplier's, or manufacturer's own letterhead, addressed to District.
 5. Warranty and guarantee letters shall be signed by all responsible parties and by Contractor in every case, with modifications only as approved in advance by District to suit the conditions pertaining to the warranty or guarantee.
- C. Manufacturer's Guarantee Form:
1. Manufacturer's guarantee form may be used in lieu of special Project form included at the end of this Section.
 2. Manufacturer's guarantee form shall contain appropriate terms and identification, ready for execution by the required parties.
 3. If proposed terms and conditions restrict guarantee coverage or require actions by District beyond those specified, submit draft of guarantee to District through Architect for review and acceptance before performance of the Work.
 4. In other cases, submit draft of guarantee to District through Architect for approval prior to final execution of guarantee.
- D. Signatures: Signatures shall be by person authorized to sign warranties, guarantees and bonds on behalf of entity providing such warranty, guarantee or bond.
- E. Co-Signature: All installer's warranties and bonds shall be co-signed by Contractor. Manufacturer's guarantees will not require co-signature.
- F. Verify that documents are in proper form, contain full information, and are notarized.
- G. Co-execute submittals when required.
- H. Retain warranties and bonds until time specified for submittal.
- I. Manual: Bind in commercial quality 8-1/2 by 11 inch three D side ring binders with durable plastic covers.
- J. Cover: Identify each binder with typed or printed title WARRANTIES AND BONDS, with title of Project; name, address and telephone number of Contractor and equipment supplier; and name of responsible company principal.
 1. If more than one volume of warranties, guarantees and bonds is produced, identify volume number on binder.
- K. Table of Contents: Neatly typed, in the sequence of the Table of Contents of the Project Manual, with each item identified with the number and title of the specification section in which specified, and the name of product or work item.
- L. Separate each warranty or bond with index tab sheets keyed to the Table of Contents listing. Provide full information, using separate typed sheets as necessary. List Subcontractor, supplier, and manufacturer, with name, address, and telephone number of responsible principal.

M. Form of Warranty and Bond Submittals:

1. Prior to final Application and Certificate for Payment, compile two copies of each required warranty, guarantee and bond, properly executed by Contractor, or jointly by Contractor, subcontractor, supplier, or manufacturer.
2. Collect and assemble all written warranties and guarantees into binders and deliver binders to District for final review and acceptance.
3. Include Table of Contents for binder, neatly typed, following order and Section numbers and titles as used in the Project Manual.
4. Provide heavy paper dividers with celluloid or plastic covered tabs for each separate warranty.
 - a. Mark tabs to identify products or installation, and Section number and title.
5. Include on separate typed sheet, if information is not contained in warranty or guarantee form, a description of the product or installation, and the name, address, telephone number and responsible person for applicable installer, supplier and manufacturer.
6. When operating and maintenance data manuals are required for warranted construction, include additional copies of each required warranty and guarantee in each required manual.
 - a. Coordinate with requirements listed in the prior articles for operating and maintenance data manuals.

3.07 TIME OF WARRANTY AND BOND SUBMITTALS

A. Submission of Preliminary Copies:

1. Unless otherwise specified, obtain preliminary copies of warranties, guarantees and bonds within ten days of completion of applicable item or Work.
2. Prepare and submit preliminary copies for review as specified herein.

B. Submission of Final Copies:

1. Submit fully executed copies of warranties, guarantees and bonds within ten days of date identified in Certificate of Completion but no later than three days prior to date of final Application for Payment.

C. Date of Warranties and Bonds:

1. Unless otherwise directed or specified, commencement date of warranty, guarantee and bond periods shall be the date established in the Certificate of Completion.
2. Warranties for Work accepted in advance of date stated in Certificate of Completion:
 - a. When a designated system, equipment, component parts or other portion of the Work is completed and occupied or put to beneficial use by District:
 - 1) By separate agreement with Contractor, prior to completion date established in the Certificate of Completion, submit properly executed warranties to District within ten days of completion of that designated portion of the Work.
 - 2) List date of commencement of warranty, guarantee or bond period as the date established in the Certificate of Completion.

3. Warranties for Work not accepted as of date established in the Certificate of Completion:
 - a. Submit documents within ten days after acceptance, listing date of acceptance as beginning of warranty, guarantee or bond period.

D. Duration of Warranties and Guarantees:

1. Unless otherwise specified or prescribed by law, warranty and guarantee periods shall be not less than the Correction Period required by the Conditions of the Contract.
2. In no case, the period is to be less than one year from the date established for completion of the Project in the Certificate of Completion.
3. See product Specifications Sections of the Project Manual for extended warranty and guarantee beyond the minimum one year duration.

END OF SECTION

**SECTION 01 78 00.01
WARRANTY FORM LETTER**

FOR CONTRACTOR'S / SUBCONTRACTOR'S / MANUFACTURER'S WARRANTY

CONTRACTOR'S/SUBCONTRACTOR'S/SUPPLIER'S LETTERHEAD

SPECIAL LIMITED PROJECT WARRANTY FOR _____ WORK.

We, the undersigned, do hereby warrant that the portion of the Work described above which we have provided for Interim Housing is in accordance with the Contract Documents and that all such Work as installed will fulfill or exceed all minimum warranty requirements. We agree to repair or replace Work installed by us, together with any adjacent Work which is displaced or damaged by so doing, that proves to be defective in workmanship, material, or function within a period of (years), commencing (date identified in Certificate of Completion, unless otherwise directed) and terminating (date).

The following terms and conditions apply to this warranty (obtain District 's approval before submission):

In the event of our failure to comply with the above-mentioned conditions within a reasonable time period determined by the District , after notification in writing, we, the undersigned, all collectively and separately, hereby authorize the District to have said defective Work repaired or replaced to be made good, and agree to pay to the District upon demand all moneys that the District may expend in making good said defective Work, including all collection costs and reasonable attorney fees.

LOCAL REPRESENTATIVE: FOR WARRANTY MAINTENANCE, REPAIR, OR REPLACEMENT SERVICE, CONTACT:

(Name) _____
(Address) _____
(City) _____ (State) _____ (ZIP) _____
(Phone) _____ / _____
(signed) _____
(Date) _____ (Typed Name) _____
(Title) _____ (Firm) _____

CONTRACTOR:

State License No: _____
(signed) _____
(Date) _____ (Typed Name) _____
(Title) _____ (Firm) _____

FORM LETTER

FORM LETTER

FOR CONTRACTOR'S / MANUFACTURER'S GUARANTEE

CONTRACTOR'S / MANUFACTURER'S LETTERHEAD

SPECIAL LIMITED PROJECT [__ WARRANTY__] [__ GUARANTEE__] FOR _____ WORK.

We, the undersigned, do hereby [__ warrant__] [__ guarantee__] that the portion of the Work described above which [__ we have provided__] [__ was provided by (Installer or Subcontractor's Name)__] for Interim Housing in accordance with the Contract Documents and that all such Work as installed will fulfill or exceed all minimum warranty requirements. We agree to repair or replace Work installed by [__ us,__] [__(Installer or Subcontractor's Name)__] together with any adjacent Work which is displaced or damaged by so doing, that proves to be defective in workmanship, material, or function within a period of (years), commencing (date indicated in Certificate of Completion, unless otherwise directed) and terminating (date).

The following terms and conditions apply to this [__ warranty__] [__ guarantee__] (obtain District's approval before submission):

In the event of our failure to comply with the above-mentioned conditions within a reasonable time period determined by the District, after notification in writing, we, the undersigned, all collectively and separately, hereby authorize the District to have said defective Work repaired or replaced to be made good, and agree to pay to the District upon demand all moneys that the District may expend in making good said defective Work, including all collection costs and reasonable attorney fees.

LOCAL REPRESENTATIVE: FOR WARRANTY MAINTENANCE, REPAIR, OR REPLACEMENT SERVICE, CONTACT:

(Name) _____
(Address) _____
(City) _____ (State) _____ (ZIP) _____
(Phone) _____ / _____
(signed) _____
(Date) _____ (Typed Name) _____
(Title) _____ (Firm) _____

CONTRACTOR:

State License No: _____
(signed) _____
(Date) _____ (Typed Name) _____
(Title) _____ (Firm) _____

FORM LETTER

END OF SECTION

SECTION 01 79 00
DEMONSTRATION AND TRAINING

PART 1 GENERAL

1.01 SUMMARY

- A. Demonstration of products and systems to be commissioned and where indicated in specific specification sections.
- B. Training of District personnel in operation and maintenance is required for:
 - 1. All software-operated systems.
 - 2. HVAC systems and equipment.
 - 3. Plumbing equipment.
 - 4. Electrical systems and equipment.
 - 5. Conveying systems.
 - 6. Landscape irrigation.
 - 7. Items specified in individual product Sections.
- C. Training of District personnel in care, cleaning, maintenance, and repair is required for:
 - 1. Roofing, waterproofing, and other weather-exposed or moisture protection products.
 - 2. Finishes, including flooring, wall finishes, ceiling finishes.
 - 3. Fixtures and fittings.
 - 4. Items specified in individual product Sections.

1.02 RELATED REQUIREMENTS

- A. Section 01 78 00 - Closeout Submittals: Operation and maintenance manuals.
- B. Section 01 91 13 - General Commissioning Requirements: Additional requirements applicable to demonstration and training.
- C. Other Specification Sections: Additional requirements for demonstration and training.

1.03 SUBMITTALS

- A. See Section 01 30 00 - Administrative Requirements, for submittal procedures.
- B. Training Plan: District will designate personnel to be trained; tailor training to needs and skill-level of attendees.
 - 1. Each Sub, Design-Builder SubContractor and vendor responsible for training submits a written training plan to the Architect and District Representative for review and approval prior to training.
 - 2. Submit to Architect for transmittal to District.
 - 3. Submit not less than four weeks prior to start of training.
 - 4. Revise and resubmit until acceptable.
 - 5. Provide an overall schedule showing all training sessions.
 - 6. Include at least the following for each training session:

- a. Identification, date, time, and duration.
 - b. Description of products and/or systems to be covered.
 - 1) Equipment list
 - c. Name of firm and person conducting training; include qualifications.
 - d. Intended audience, such as job description.
 - e. Objectives of training and suggested methods of ensuring adequate training.
 - 1) Agenda and subjects (design intent, equipment inspections, modes of operation, system interactions, troubleshooting, preventative maintenance, etc.)
 - f. Methods to be used, such as classroom lecture, live demonstrations, hands-on, etc.
 - g. Media to be used, such as slides, hand-outs, etc.
 - 1) The approved O&M manuals shall be used during the training for equipment specific references.
 - h. Training equipment required, such as projector, projection screen, etc., to be provided by Contractor.
- C. Training Manuals: Provide training manual for each attendee; allow for minimum of two attendees per training session.
- 1. Include applicable portion of O&M manuals.
 - 2. Include copies of all hand-outs, slides, overheads, video presentations, etc., that are not included in O&M manuals.
 - 3. Provide one extra copy of each training manual to be included with operation and maintenance data.
- D. Training Reports:
- 1. Identification of each training session, date, time, and duration.
 - 2. Sign-in sheet showing names and job titles of attendees.
 - 3. List of attendee questions and written answers given, including copies of and references to supporting documentation required for clarification; include answers to questions that could not be answered in original training session.
 - 4. Include Commissioning Authority's formal acceptance of training session.
- E. Video Recordings: Submit digital video recording of each demonstration and training session for District's subsequent use.
- 1. Format: DVD Disc.
 - 2. Label each disc and container with session identification and date.

1.04 QUALITY ASSURANCE

- A. Instructor Qualifications: Familiar with design, operation, maintenance and troubleshooting of the relevant products and systems.
- 1. Provide as instructors the most qualified trainer of those contractors and/or installers who actually supplied and installed the systems and equipment.
 - 2. Where a single person is not familiar with all aspects, provide specialists with necessary qualifications.

PART 2 PRODUCTS - NOT USED

PART 3 EXECUTION

3.01 TRAINING OF OWNER PERSONNEL

- A. The Contractor and Design-Builder SubContractors shall be responsible for training coordination and scheduling and for ensuring that training is completed.
- B. The Commissioning Authority (CA) shall be responsible for reviewing and approving the content of the training of Owner personnel for commissioned equipment.
- C. The specific training requirements of District personnel by Subs, Design-Builder SubContractors and vendors is specified in the Division in which the equipment is specified.
- D. For primary HVAC equipment, the Controls Contractor shall provide a short discussion of the control of the equipment during the mechanical or electrical training conducted by others.

3.02 DEMONSTRATION - GENERAL

- A. Demonstrations conducted during system start-up do not qualify as demonstrations for the purposes of this section, unless approved in advance by District.
- B. Demonstrations conducted during Functional Testing need not be repeated unless District personnel training is specified.
- C. Demonstration may be combined with District personnel training if applicable.
- D. Operating Equipment and Systems: Demonstrate operation in all modes, including start-up, shut-down, seasonal changeover, emergency conditions, and troubleshooting, and maintenance procedures, including scheduled and preventive maintenance.
 - 1. Perform demonstrations not less than two weeks prior to Substantial Completion.
 - 2. For equipment or systems requiring seasonal operation, perform demonstration for other season within six months.
- E. Non-Operating Products: Demonstrate cleaning, scheduled and preventive maintenance, and repair procedures.
 - 1. Perform demonstrations not less than two weeks prior to Substantial Completion.

3.03 TRAINING - GENERAL

- A. Commissioning Authority will prepare the Training Plan based on draft plans submitted.
- B. Conduct training on-site unless otherwise indicated.
- C. District will provide classroom and seating at no cost to Contractor.
- D. Do not start training until Functional Testing is complete, unless otherwise specified or approved by the Commissioning Authority.
- E. Provide training in minimum two hour segments.
- F. The Commissioning Authority is responsible for determining that the training was satisfactorily completed and will provide approval forms.
- G. Training schedule will be subject to availability of District's personnel to be trained; re-schedule training sessions as required by District; once schedule has been approved by

District failure to conduct sessions according to schedule will be cause for District to charge Contractor for personnel "show-up" time.

- H. Review of Facility Policy on Operation and Maintenance Data: During training discuss:
 - 1. The location of the O&M manuals and procedures for use and preservation; backup copies.
 - 2. Typical contents and organization of all manuals, including explanatory information, system narratives, and product specific information.
 - 3. Typical uses of the O&M manuals.
- I. Product- and System-Specific Training:
 - 1. Review the applicable O&M manuals.
 - 2. For systems, provide an overview of system operation, design parameters and constraints, and operational strategies.
 - 3. Review instructions for proper operation in all modes, including start-up, shut-down, seasonal changeover and emergency procedures, and for maintenance, including preventative maintenance.
 - 4. Provide hands-on training on all operational modes possible and preventive maintenance.
 - 5. Emphasize safe and proper operating requirements; discuss relevant health and safety issues and emergency procedures.
 - 6. Discuss common troubleshooting problems and solutions.
 - 7. Discuss any peculiarities of equipment installation or operation.
 - 8. Discuss warranties and guarantees, including procedures necessary to avoid voiding coverage.
 - 9. Review recommended tools and spare parts inventory suggestions of manufacturers.
 - 10. Review spare parts and tools required to be furnished by Contractor.
 - 11. Review spare parts suppliers and sources and procurement procedures.
- J. Be prepared to answer questions raised by training attendees; if unable to answer during training session, provide written response within three days.

END OF SECTION

SECTION 02 41 00
DEMOLITION

PART 1 - GENERAL

1.01 SUMMARY

- A. Section Includes: Furnishing all labor, materials and equipment necessary for demolition, dismantling, cutting and alterations as indicated, specified, and required for completion of the Contract, as applicable. Includes items such as the following:
 - 1. Protecting existing work to remain.
 - 2. Cleaning soiled materials that are to remain.
 - 3. Disconnecting and capping utilities.
 - 4. Removing debris and equipment.
 - 5. Removal of items indicated on Drawings.
 - 6. Salvageable items to be retained by the Owner as indicated on the Drawings and during the pre-construction job walk.

- B. Related Sections:
 - 1. Section 31 22 00: Grading

1.02 QUALITY ASSURANCE

- A. Comply with the following:
 - 1. Applicable codes, ordinances, regulations of local, municipal, state and federal authorities having jurisdiction.
 - 2. Comply strictly to Rule 403 Fugitive Dust, South Coast Air Quality Management District.
 - 3. Obtain necessary permits and notices, post where required.
 - 4. Comply with safety requirements of the local fire department.
 - 5. Comply with ANSI A10.6.

- B. Notify affected utility companies before starting Work and comply with their requirements.

- C. Carefully perform demolition work, by skilled workers experienced in building demolition procedures, using appropriate tools and equipment. Perform work, at all times, under the direct supervision of a supervisor approved by the Owner Inspector.

- D. Coordinate demolition with other trades to ensure correct sequence, limits, and methods of proposed demolition. Schedule work to create least possible inconvenience to the public and to facility operations.
- E. Pre-Demolition: Conduct conference at Project site 7 days prior to scheduled installation.
 - 1. Conference agenda shall include review and discussion of requirements of authorities having jurisdiction, instructions and requirements of serving utilities, sequencing and interface considerations and Project conditions.
 - 2. Conference shall be attended by supervisory and quality control personnel of Contractor and all subcontractors performing this and directly related work. Submit minutes of meeting to Design Builder's Representative for Project record purposes.

1.03 DEFINITIONS

- A. Remove: Remove and legally dispose of items except those indicated to be reinstalled, salvaged, or to remain the Owner's property.
- B. Remove and Salvage: Items indicated to be removed and salvaged remain the Owner's property. Remove, clean, and pack or crate items to protect against damage. Identify contents of containers and deliver to location as directed by Owner's Representative.
- C. Remove and Reinstall: Remove items indicated; clean, service, and otherwise prepare them for reuse; store and protect against damage. Reinstall items in locations indicated.
- D. Existing to Remain: Protect construction indicated to remain against damage and soiling during demolition. When permitted by the Owner's Representative, items may be removed to a suitable, protected storage location during demolition and then cleaned and reinstalled in their original locations.
- E. Replace: Remove and legally dispose of existing item(s) indicated and install new like item(s) that conform to project specifications.

1.04 OWNERSHIP OF MATERIALS

- A. Ownership of Materials: Except for items or materials indicated to be reused, salvaged, or otherwise indicated to remain the Owner's property, demolished materials shall become the Contractor's property and shall be removed from the site with further disposition at the Contractor's option.

1.05 PROJECT CONDITIONS

- A. Drawings may not indicate in detail all demolition work to be carried out. Carefully examine existing conditions to determine full extent of demolition required. All utilities, whether shown on the drawings or not, to be capped at the property line U.N.O.
- B. Repair damage due to demolition activities to existing improvements to remain at no additional cost to the Owner. Repair or replace as directed by the Owner Inspector.

- C. Take measures to avoid excessive damage from inadequate or improper means and methods, or improper shoring, bracing or support. Repair or replace any resulting damage at no additional cost to the owner as directed by the Owner Inspector.
- D. If conditions are encountered that vary from those indicated, notify the Owner Inspector for instructions prior to proceeding. Owner assumes no responsibility for actual condition of structures to be demolished.
- E. Inform Owner immediately upon discovery of asbestos products, radioactive materials, toxic wastes or other hazardous materials. Do not remove hazardous materials without Owner authorization.
- F. Adjacent roadways/passageways:
 - 1. Maintain fire department access through all phases of the project.
 - 2. Obstruction of streets, walks or other adjacent facilities will not be allowed.

1.06 DIG ALERT NOTIFICATION

- A. Before any excavation in or near the public right-of-way, the Contractor must contact the Underground Service Alert of Southern California (Dig Alert) at **811** for information on buried utilities and pipelines.
- B. Delineation of the proposed excavation site is mandatory. Mark the area to be excavated with water soluble or chalk based white paint on paved surfaces or with other suitable markings such as flags or stakes on unpaved areas.
- C. Call at least Two (2) full working days prior to digging.
- D. If the members (utility companies) have facilities within the work area, they will mark them prior to the start of your excavation and if not, they will let you know there is no conflict. A different color is used for each utility type (electricity is marked in red, gas in yellow, water in blue, sewer in green, telephone and cable TV in orange).
- E. The Law requires you to hand expose to the point of no conflict 24" (inches) on either side of the underground facility, so you know its exact location before using power equipment.
- F. If caught digging without a Dig Alert ticket you can be fined as much as \$50,000 per California government code 4216.

PART 2 - PRODUCTS

2.01 SOIL MATERIALS

- A. Satisfactory Soil Materials: Refer to section 31 22 00 Grading.
- B. Backfill & Native Fill Materials: Refer to section 31 22 00 Grading.

- C. Borrow / Imported Fill Material: Refer to section 31 22 00 Grading.
- D. Engineered Fill: All engineered fill should be placed on competent, scarified and compacted bottom as evaluated by the geotechnical engineer. Prior to compaction, fill materials should be thoroughly mixed and moisture conditioned to within three (3) percent of the optimum moisture content for granular soils and to approximate three (3) percent above the optimum moisture for fine-grained soils. Fill soils shall be evenly spread in maximum 8-inch lifts, watered or dried as necessary, mixed and compacted to at least the density specified below. The fill shall be placed and compacted on a horizontal plane, unless otherwise approved by the geotechnical engineer. All fill, if not specified otherwise elsewhere in this report, should be compacted to at least 90 percent of the laboratory dry density in accordance with the ASTM Standard D2922 test method.

2.02 HANDLING OF MATERIALS

- A. Items scheduled for salvage by the Owner shall be delivered to a location designated by the Owner’s Authorized Representative. Items shall be cleaned, packaged and labeled for storage.
- B. Items scheduled for reuse shall be stored on site and protected from damage, soiling and theft.

PART 3 - EXECUTION

3.01 GENERAL

- A. Protection:
 - 1. Do not begin demolition until safety partitions, barricades, warning signs and other forms of protection are installed.
 - 2. Provide safeguards, including warning signs, lights and barricades, for protection of occupants and the general public during demolition.
 - 3. Provide and maintain fire extinguishers. Comply with requirements of governing authorities.
 - 4. Maintain existing utilities which are to remain in service and protect from damage during operations.
- B. Safety: If at any time safety of existing construction appears to be endangered, take immediate measures to correct such conditions; cease operations and immediately notify the Owner Inspector. Do not resume demolition until directed by the Owner Inspector.
- C. Noise and Dust Abatement: Exercise all reasonable and necessary means to abate dust, dirt rising and undue noise. Perform necessary sprinkling and wetting of construction site to allay dust as required by applicable codes and ordinances
- D. Dust Control: Use water mist, temporary enclosures, and other suitable methods to limit the spread of dust and dirt. Comply with governing environmental protection regulations. Do not

create hazardous or objectionable conditions, such as flooding and pollution, when using water.

- E. Water for Dust Control: Contractor shall obtain and pay for all water required for his dust control operations. This may include, but is not limited to, payment of deposits to utility for construction meter, and payment of all monthly service and water charges. Construction meter shall be in place throughout construction period unless alternative arrangements are made with the Long Beach Water Department to provide construction water for all purposes. Contractor shall be aware of water moratoriums and restrictions, and shall immediately advise Owner of effects on construction schedules.
- F. An 8 foot high, chain link fence and gates, shall be erected prior to any demolition operations at the construction limits perimeter. Coordinate the exact location with Owner.
- G. Debris Removal: Remove and transport debris in a manner that will prevent spillage on adjacent surfaces and areas. Remove debris from elevated portions of building by chute, hoist, or other device that will convey debris to grade level.
- H. Progress Cleaning: Clean adjacent buildings and improvements of dust, dirt, and debris caused by demolition operations. Return adjacent areas to condition existing before start of demolition.
- I. Where performing contracted scope of work requires coring of existing concrete, brick masonry, or CMU structures (including Walls, Floors, and Sitework), contractor shall obtain and document means of verifying existence and location of embedded steel reinforcing materials within said concrete, brick and CMU assemblies. Contractor shall locate reinforcement by means of non-invasive technology such as X-ray photography for the purposes of protecting said reinforcement in place and shall not damage any reinforcement materials (rebar, etc.) unless specifically detailed as such and approved by the authority having jurisdiction.
- J. Perform surveys as the Work progresses to detect hazards resulting from selective demolition activities.
- K. Drain, purge, or otherwise remove, collect, and dispose of chemicals, gases, explosives, acids, flammables, or other dangerous materials before proceeding with selective demolition operations.
- L. Contractor shall provide temporary weather protection, during interval between demolition and removal of existing construction, on exterior surfaces and new construction to ensure that no water leakage or damage occurs to structure or interior areas.
- M. Provide and maintain interior and exterior shoring, bracing, or structural support to preserve stability and prevent movement, settlement, or collapse of building to be selectively demolished.
- N. Clean adjacent structures and improvements of dust, dirt, and debris caused by selective demolition operations. Return adjacent areas to condition existing before start of selective demolition.

- O. Where repairs to existing surfaces are required, patch to produce surfaces suitable for new materials if exposed, repaired surfaces shall match existing adjacent surface color finish and texture.
 - 1. Restore exposed finishes of patched areas and extend finish restoration into adjoining construction to remain in a manner that eliminates evidence of patching and refinishing.
- P. Disposal: Promptly dispose of demolished materials. Do not allow demolished materials to accumulate on-site.

3.02 PREPARATION

- A. Prevent movement or settlement of adjacent structures. Provide bracing and shoring as necessary.
- B. Utilities:
 - 1. The Drawings do not purport to show all below-grade conditions and objects on the site. Contractor shall perform field investigations as necessary to establish location of underground utility services and other features affecting earthwork.
 - 2. Mark location of underground utilities on asphalt pavement with paint
 - 3. Disconnect and cap utility services; comply with requirement of governing authorities.
 - 4. Contractor shall arrange and notify utility company in advance of date and time when service needs to be disconnected.
 - 5. Do not commence demolition operations until associated disconnections have been completed.
 - 6. Should utilities and other below-grade conditions be encountered which adversely affect the Work, discontinue affected Work and notify Owner's Representative and Architect and request direction. Unforeseen conditions will be resolved in accordance with provisions of the General Conditions of the Contract.
 - 7. Should a utility line or structure be damaged, immediately notify the responsible utility company or agency and notify Owner's Representative and Architect.
 - a. Repair or replace all damaged utility lines and structures as directed by the responsible utility company or agency.
 - b. Repair or replacement of damaged utility lines and structures whole location or existence has been made known to the Contractor shall be at no change in the Contract Time and Contract Price.
- C. Structures to be demolished shall be inspected for hazardous materials. Such materials shall be removed and disposed of before general demolition begins.

- D. Do not interrupt existing utilities serving occupied or operating facilities, except when authorized in writing by Owner's Representative and Authority Having Jurisdiction (AHJ). Provide temporary services during interruptions to existing utilities, as acceptable to Owner's Representative and to Authority Having Jurisdiction (AHJ).

3.03 EXPLOSIVES

- A. Explosives: Use of explosives will not be permitted.

3.04 DEMOLITION

- A. Demolition, General:

1. With certain exceptions, the Contractor shall raze, remove and dispose of all buildings and foundations, structures, paving, fences and other obstructions that lie wholly or partially within the construction limits identified on Drawings. The exceptions are utility-owned equipment and any other items the Owner/Documents may direct the Contractor to leave intact or re-use onsite. Cease demolition immediately if adjacent structures appear to be in danger.
2. Conduct demolition operations and remove debris to ensure minimum interference with roads, streets, walks, and other adjacent occupied and used facilities.
3. Do not close or obstruct streets, walks, or other adjacent occupied or used facilities without permission from Owner's Representative and Authority Having Jurisdiction (AHJ). Provide alternate routes around closed or obstructed traffic ways if required by governing regulations.
4. Conduct demolition operations to prevent injury to people and damage to adjacent buildings and facilities to remain. Ensure safe passage of people around demolition area.
 - a. Erect temporary protection, such as walks, fences, railings, canopies, and covered passageways, where required by authorities having jurisdiction.
 - b. Protect existing site improvements, appurtenances, and landscaping to remain.
 - c. Completely remove below-grade construction, including foundation walls and footings.
5. Filling Below-Grade Areas: Completely fill below-grade areas and voids resulting from demolition of buildings and pavements with soil materials according to requirements specified in Section 31 22 00- Grading.
6. Damages: Promptly repair damages to adjacent facilities caused by demolition operations.
7. Unless otherwise indicated on the plans, remove all demolished material from the site and dispose of at approved disposal sites. Comply with all requirements

for recycling of demolished material as called for in Division 1 of this Specification. The contractor shall obtain necessary permits for the transportation of material from the site.

3.05 REMOVAL OF EXISTING PLUMBING AND ELECTRICAL EQUIPMENT AND SERVICES

- A. Remove existing plumbing and electrical equipment fixtures and services not indicated for reuse and not necessary for completion of work. Remove abandoned lines and cap unused portions of existing lines. The Contractor is responsible for completely surveying the site and locating all existing utilities, above and below ground, before contracting to perform the work.

- B. Asbestos – Cement (A-C) Pipe Removal and Disposal: The plans for the project may indicate that existing asbestos-cement pipe is to be removed from the ground. Where so indicated the Contractor shall excavate with care, expose the pipeline and remove the A-C pipe to the nearest joint. Should the plans not call out the removal of the A-C pipe and A-C pipe is encountered, the Contractor shall obtain approval from the Owner as to whether or not the A-C pipe is to be removed or can be left in place. Cutting of the pipe shall only be done if absolutely there is no other way to expose the length of pipe to the nearest joint that be separated and the Owner approves the cutting of the pipe. Cutting of the pipe shall be done with a mechanical saw with a pressure water source to dampen the pipe and the dust from the cutting. To remove a coupling, the coupling may have to be broken in the trench. The pipe once removed from the trench may be broken for handling. The breaking shall be done within a plastic bagging or sheeting material to minimize the release of asbestos fibers into the atmosphere. Once removed and broken, if necessary, the A-C material shall be bagged and disposed of legally with the Owner to be given a copy of all Contractor paperwork as to the legal disposal of the material. If the A-C pipe section(s) are removed intact the pipe can be removed by the Contractor from the project site and become the property and responsibility of the Contractor.

3.06 CLEANING

- A. Clean existing materials to remain, using appropriate tools and materials.

- B. Protect adjacent materials and equipment during cleaning operations.

3.07 RESTORATION

- A. Restoration of Site Finishes:
 - 1. Concrete paving: Where it is necessary to excavate a trench across make a cut in concrete paved areas, cut concrete cutting saw, full depth of paving.

 - 2. Bituminous paving: Where it is necessary to excavate a trench across make a cut in bituminous paved areas, either first score paving with a concrete cutting saw, in neat straight lines, prior to removing paving or make straight cuts with pneumatic spade.

 - 3. Restoration of paving: Restore all paved areas to their original condition using material of like type and quality as the removed paving. Paving in public ways shall conform to applicable requirements of authorities having jurisdiction.

Repaired surfaces shall match existing adjacent paving except minimum depth shall be 3-1/2 inches where existing paving is less than 3-1/2 inches.

4. Restoration of landscape planting: Restore soil and plant materials to match original condition, including additional topsoil, topsoil grading and preparation, new plant materials and plant maintenance during establishment period.

3.08 MAINTENANCE

- A. Install and maintain all erosion control devices, including sandbag and gravel bag dikes, silt fences, de-silting basins, inlet barricades, vehicle wash traps, and other features called for in specification 01 57 23 Temporary Storm Water Pollution Control.

3.09 CLEAN-UP/DISPOSAL

- A. Coordinate building access with the Owner Inspector. Review and schedule waste storage and removal, include truck access to site.
- B. Debris shall be dampened by fog water spray prior to transporting by truck.
- C. Debris pick-up area shall be kept broom-clean and shall be washed daily with clean water.
- D. Remove waste and debris, other than items to be salvaged. Turn over salvaged items to Owner, or store and protect for reuse where scheduled. Continuously clean-up and remove items as demolition work progresses. Do not allow waste and debris to accumulate in building or on site.

END OF SECTION

SECTION 02 43 00
STRUCTURE MOVING

PART 1 GENERAL

1.01 SECTION INCLUDES

- A. Preparing structure for move.
- B. Moving existing relocatable classroom building structure to new location.
- C. Setting structure on new foundation.
- D. Disconnecting and capping utilities at original location.
- E. Connecting utilities at new location.

1.02 RELATED REQUIREMENTS

- A. Section 02 41 00 - Demolition: Removal of existing foundation after structure removal.
- B. Section 31 22 00 - Grading: Rough and finish grading.

1.03 ADMINISTRATIVE REQUIREMENTS

- A. Arrange for route of move with authorities having jurisdiction and comply with its requirements for the move including, but not limited to, traffic control, police escorts, and relocation of overhead utility services in the route.
- B. Coordination: Ensure utilities at new location are ready for connection.
- C. Pre-Move Meeting: Convene one week before starting work of this section. Discuss the following:
 - 1. Method of determining damage to existing structure and finishes before and after the move.
 - 2. Identify existing damage to sidewalks, roads, and curbs.
 - 3. Method and responsibility for repairs after moving.
 - 4. Review the intended route for moving and dimensional clearances of obstructions.
 - 5. Coordination with affected utility companies.
 - 6. Coordination with authorities for permits, municipalities affected, and traffic control.

1.04 SUBMITTALS

- A. See Section 01 30 00 - Administrative Requirements, for submittal procedures.
- B. Project Record Documents: Record actual locations of new utilities and services, foundations

1.05 QUALITY ASSURANCE

- A. Mover Qualifications: Company specializing in relocating building structures with minimum of five years of documented experience.
 - 1. Company specializing in moving portable classroom building structures.
 - 2. Current State of California Category C-21 license.

- B. Retain services of a Professional Structural Engineer experienced in this Work and licensed in California for the following:
 - 1. To investigate and provide documented report confirming load bearing capacity of roads over which structure will be moved.
 - 2. To design structural supports for existing structure and associated Work. Design framing, reinforcement, and brace connections to transfer loads of structure to transport carrying equipment.
- C. Insurance: Company must show proof of one million dollars (\$1,000,000.00) in general liability insurance.

1.06 REGULATORY REQUIREMENTS

- A. Conform to applicable municipal ordinances; obtain permits, licenses and pay deposit sums; arrange for route of move; disconnect and reconnect utility services on route.
- B. When relocation occurs off-site, arrange with authorities having jurisdiction for traffic control, police escorts, relocation of services and interim structure locations.

1.07 SCHEDULING

- A. Arrange schedule with District's requirements for sequence of work under this contract.
- B. No transporting of the relocatable buildings to any of the designated sites, neither any movement on site will be permitted no later than (30 min.) before and no earlier than (30 min.) after school hours.
- C. A school schedule stating times and activities for each school site will be issued at the Pre-Construction Meeting.

PART 2 PRODUCTS

2.01 EQUIPMENT AND MATERIALS

- A. Transport, Equipment, and Supports: As required to achieve a successful structure move.
- B. Fill Materials: As specified in Section 31 23 23.

PART 3 EXECUTION

3.01 EXAMINATION

- A. Visit District' proposed sites, where shown on Drawings, for moving of portables, route of transport and sites of destination.
- B. Verify on-site surface load limits to ensure conditions are adequate to support moving loads of structure.
- C. Verify availability and accessibility of transport routes. Verify route load limits to ensure conditions are adequate to support moving loads of structure.
- D. Identify utility services and obstructions to be removed, relocated, or abandoned during progress of the Work.
- E. Inspect structure thoroughly and notify Architect in writing of visible defects, structural or otherwise, which would affect safe movement of structures to final location.

- F. Damage Determination:
 - 1. Before the move, inspect existing structure thoroughly and notify Architect in writing of visible defects and factors that could affect safe movement of structure to final location.
 - 2. Compile list of existing visible defects to building structure, finishes, accessories . This list will form the basis for determining required repair work after the move.
 - 3. Photograph for record purposes.
- G. Beginning work of this section means acceptance of existing conditions.

3.02 PREPARATION

- A. Prepare site, route of transport, and destination site.
- B. Protect road as necessary to safely move the structures and to prevent damage.
- C. Coordinate the work of utility disconnection and reconnection with the work of this section.
- D. Disconnect and cap existing site utility services. Remove overhead or exposed utility services to provide clear working and moving space around and below structure.
- E. Remove building protrusions prior to move.
- F. Secure supplementary framing and bracing to structure.
- G. Secure operating, moving, or suspended items such as doors, windows, cabinetry, and light fixtures in a manner to prevent damage to items or to the structure during move.
- H. Protect elements surrounding the structure from damage.

3.03 RAISE STRUCTURE

- A. Cut structure free of foundation and portions of structure not being moved.
- B. Reinforce, brace, and raise structure clear of foundation in manner to prevent damage.
- C. Provide necessary framing, bracing, closures, supports, and blocking.
- D. Secure structure to temporary supporting structural members to prevent shifting of structure during move.

3.04 MOVE STRUCTURE

- A. Provide transport vehicles for moving structure to new site.
- B. Move structure, control speed, and provide anchor and restraining devices to maintain the integrity of the structure.
- C. During move, protect adjacent structures, and private and public property from damage.

3.05 REINSTALL STRUCTURE

- A. Position and anchor structure over prepared foundation and lower onto new foundation.
 - 1. Anchor structure to foundation in accordance with Architectural / Manufacturer's Drawings.
- B. Attach individual units to each other at mod-lines to provide a complete building.
 - 1. Attach in accordance with Architectural / Manufacturer's Drawings.
 - 2. Provide all material requirements to attach units.

- C. Remove moving equipment.
- D. Leave reinforcing, framing, and bracing intact until structure is fully attached and structure loads are supported by new foundation.
- E. Reinstall building protrusions removed prior to move.

3.06 TOLERANCES

- A. Maximum Variation from Level and Plumb After Reinstallation: 1/4 inch.
- B. Maximum Offset from True Position After Reinstallation: 1/4 inch.
- C. Adjust structure on foundation:
 - 1. To permit doors to swing freely.
 - 2. So that floor surfaces are level, walls are plumb.

3.07 DAMAGE REPAIR

- A. Repair damage to structure not identified in writing prior to move.
 - 1. Repair or remove and replace with new material, damage which cannot be repaired to the satisfaction of the Architect.
- B. Refinish repaired surfaces to match adjacent work.
- C. Pay all third party claims for incidental or other damage.
- D. Refer to Section 01 70 00 - Execution and Closeout Requirements.

3.08 ORIGINAL SITE

- A. Original supports for structure shall be collected and turned over to District.

3.09 CLEANING

- A. Remove moving equipment and materials from original site, final site, and route of travel.
- B. Remove road base constructed by this section, fill and return grades and contours to original condition and dimension.

END OF SECTION

SECTION 03 10 00
CONCRETE FORMING AND ACCESSORIES

PART 1 GENERAL

1.01 SECTION INCLUDES

- A. Formwork for cast-in place concrete, with shoring, bracing and anchorage.
- B. Openings for other work.
- C. Form accessories.
- D. Form stripping.

1.02 RELATED REQUIREMENTS

- A. Section 03 20 00 - Concrete Reinforcing.
- B. Section 03 30 00 - Cast-in-Place Concrete.
- C. Section 04 20 00 - Unit Masonry: Reinforcement for masonry.
- D. Section 05 50 00 - Metal Fabrications: Placement of embedded steel anchors and plates in cast-in-place concrete.
- E. Section 32 13 13 - Concrete Paving: Sidewalks, curbs and gutters.

1.03 REFERENCE STANDARDS

- A. ACI 117 - Specifications for Tolerances for Concrete Construction and Materials.
- B. ACI 301 - Specifications for Structural Concrete.
- C. ACI 318 - Building Code Requirements for Structural Concrete and Commentary.
- D. ACI 347R - Guide to Formwork for Concrete.
- E. PS 1 - Structural Plywood.
- F. CBC Chapter 19A.

1.04 DEFINITIONS

- A. Unexposed Finish: A general-use finish, with no appearance criteria, applicable to all formed concrete concealed from view after completion of construction.
- B. Exposed Finish: A general-use finish applicable to all formed concrete exposed to view and including surfaces which may receive a paint coating (if any).

1.05 SUBMITTALS

- A. See Section 01 30 00 - Administrative Requirements, for submittal procedures.
- B. Product Data: Provide data on void form materials and installation requirements.
 - 1. Form release agent.
- C. Shop Drawings: Indicate pertinent dimensions, materials, bracing, and arrangement of joints and ties.

1.06 QUALITY ASSURANCE

- A. Industry Standard: Formwork design and construction shall be in accordance with ACI 301, ACI 318, and ACI 347R.
- B. Maintain one copy of each installation standard on site throughout the duration of concrete work.
- C. Regulatory Requirements: Conform to formwork construction requirements of the California Building Code (CBC) Title 24, Part 2, Chapter 19A as amended and adopted by authorities having jurisdiction.

1.07 DELIVERY, STORAGE, AND HANDLING

- A. Deliver prefabricated forms and installation instructions in manufacturer's packaging.
- B. Store prefabricated forms off ground in ventilated and protected manner to prevent deterioration from moisture.

PART 2 PRODUCTS

2.01 FORMWORK - GENERAL

- A. Provide concrete forms, accessories, shoring, and bracing as required to accomplish cast-in-place concrete work.
- B. Design and construct concrete that complies with design with respect to shape, lines, and dimensions.
- C. Chamfer outside corners of beams, joists, columns, and walls.
- D. Comply with applicable state and local codes with respect to design, fabrication, erection, and removal of formwork.
- E. Comply with relevant portions of ACI 347R, ACI 301, and ACI 318.
- F. Provide materials for contact with concrete which impart suitable surface quality to completed concrete. Use the following form types:
 - 1. Forms for Exposed Finish Concrete:
 - a. Plywood, metal, metal-framed plywood faced, or other acceptable panel-type materials to provide continuous, straight, smooth, exposed surfaces.
 - b. Furnish in largest practical sizes to minimize number of joints and to conform to joint system shown on the Drawings.
 - 2. Forms for Unexposed Finish Concrete:
 - a. Plywood, lumber, metal, or another acceptable material.
 - b. Provide lumber dressed on at least two edges and one side for tight fit.
 - c. When unexposed concrete is intended to receive waterproofing, provide form as for exposed finish concrete.
- G. Provide materials to construct formwork to support forming materials in contact with concrete, of sufficient capacity to withstand pressures of concrete placement and to support concrete in place until cured, without distortion.

2.02 WOOD FORM MATERIALS

- A. Softwood Plywood for Concealed Surfaces: PS 1, undamaged face C Grade, Group 2 Plugged EXT or APA Structural I Sheathing.
- B. Hardboard: For curved surfaces, tempered hardboard, Masonite Corp., or equal.
- C. Lumber: Douglas fir or douglas fir-larch species; appropriate for intended use grade; with grade stamp clearly visible.
 - 1. Sound and undamaged straight edges, and solid knots, to maintain principal shores to support concrete until minimum strength is achieved as approved by Structural Engineer.
- D. Embedded Nailers: Clear all heart redwood or pressure preservative-treated (PPTDF) douglas fir, edges reverse beveled to key into concrete.

2.03 FORMWORK ACCESSORIES

- A. Form Ties: Removable, adjustable-length or snap-off type, galvanized metal, fixed length, cone type, with waterproofing washer, free of defects that could leave holes larger than 1 inch in concrete surface.
- B. Form Release Agent: Capable of releasing forms from hardened concrete without staining or discoloring concrete or forming bugholes and other surface defects, compatible with concrete and form materials, and not requiring removal for satisfactory bonding of coatings to be applied.
 - 1. Do not use materials containing diesel oil or petroleum-based compounds.
 - 2. Does not impair subsequent treatments of concrete surfaces or bond of applied coatings.
 - 3. VOC Content: In compliance with applicable local, State, and federal regulations.
 - 4. Products:
 - a. SpecChem, LLC; Bio Strip WB (water-based): www.specchemllc.com/#sle.
 - b. W. R. Meadows, Inc; Duogard: www.wrmeadows.com/#sle.
 - c. Substitutions: See Section 01 60 00 - Product Requirements.
- C. Nails, Spikes, Lag Bolts, Through Bolts, Anchorages: Sized as required, of sufficient strength and character to maintain formwork in place while placing concrete.
- D. Embedded Anchor Shapes, Plates, Angles and Bars: As specified in Section 05 50 00.
- E. Screed Pins and Chairs:
 - 1. Provide units that leave no metal closer than 1-1/2 inch to the plane of the exposed concrete surface.
 - 2. Manufacturers:
 - a. Grann Adjustable Quick Screed (800/554-7266).
 - b. Dayton Richmond (800/745-3700).
 - c. Aztek (877/531-3344).
 - d. Substitutions: See Section 01 60 00 - Product Requirements.

PART 3 EXECUTION

3.01 EXAMINATION

- A. Verify lines, levels and centers before proceeding with formwork. Ensure that dimensions agree with drawings.

3.02 SYSTEM REQUIREMENTS

- A. Formwork Design Requirements: Formwork products and execution specified herein are for finish surface quality only.
 - 1. Design, layout and construction of formwork shall be solely the responsibility of the Contractor.
 - 2. Design and construct formwork, shoring and bracing to conform to California Building Code (CBC), Title 24, Part 2, Chapter 19A requirements and ACI 318.
 - 3. Resulting concrete shall conform to shapes, lines and dimensions indicated and required.
- B. Coordination:
 - 1. Coordinate Work specified in this Section with other Sections which require placement of embedded products and provision of openings and recesses.
 - 2. If formwork is placed after reinforcement, resulting in insufficient concrete cover over reinforcement, request instructions from the Architect before proceeding.

3.03 EARTH FORMS

- A. Earth (Soil) Forms, General: Except as otherwise indicated on Drawings, conform to ACI 301, ACI 347R and California Building Code (CBC) requirements. Refer also to notes on Structural Drawings.
- B. Hand trim sides and bottom of earth forms. Remove loose soil prior to placing concrete.

3.04 ERECTION - FORMWORK

- A. Erect formwork, shoring and bracing to achieve design requirements, in accordance with requirements of ACI 301, ACI 347R and California Building Code (CBC) Title 24, Part 2 requirements.
- B. Provide bracing to ensure stability of formwork. Shore or strengthen formwork subject to overstressing by construction loads.
 - 1. Use form ties of sufficient strength and sufficient quantities to prevent formwork spreading.
 - 2. Maintain principal shores to support concrete until minimum required strength is achieved.
- C. Arrange and assemble formwork to permit dismantling and stripping. Do not damage concrete during stripping. Permit removal of remaining principal shores.
 - 1. Design and fabricate forms for easy removal, without impact, shock, or damage to concrete surfaces or other portions of the work.
 - 2. Design to support all applied loads until concrete is adequately cured, within allowable tolerances and deflection limits.

- D. Align joints and make watertight. Keep form joints to a minimum. Make forms watertight to prevent leakage of concrete mortar. Locate form joints, at exposed concrete, to be symmetrical about center of panel, unless otherwise noted. Align joints symmetrically at exposed conditions.
- E. Permanent openings: Provide openings to accommodate Work specified in other Sections. Size and locate openings accurately. Securely support items built into forms; provide additional bracing at openings and discontinuities in formwork.
- F. Temporary openings: Provide temporary openings for cleaning and inspection. Provide drain openings at bottoms of formwork to allow water to drain. Locate temporary openings in most inconspicuous locations at base of forms, closed with tight-fitting panels designed to minimize appearance of joints in finished concrete Work.
- G. Obtain approval before framing openings in structural members that are not indicated on drawings.
- H. Coordinate this section with other sections of work that require attachment of components to formwork.
- I. If formwork is placed after reinforcement, resulting in insufficient concrete cover over reinforcement, request instructions from Architect before proceeding.
- J. Inspection: Before placing of concrete, and after placement of reinforcing steel in the forms, provide notification so that proper inspection can be made. Make such notification at least 2 working days in advance of placing concrete.
- K. Rejection of Defective Work: Any movement or bellying of forms during construction or variations in excess of the tolerances specified shall be considered just cause for the removal of such forms and, in addition, the concrete construction so affected. Reconstruct forms, place new concrete and required reinforcing steel at no additional cost to the District.

3.05 APPLICATION - FORM RELEASE AGENT

- A. Form Release Agent: Provide either form materials with factory applied non-absorptive liner or field applied form coating to comply with applicable air quality regulations for VOC. If field applied coating is employed, thoroughly clean and recondition formwork and reapply coating before each use. Rust on form surfaces is not acceptable.
- B. Apply form release agent on formwork in accordance with manufacturer's recommendations.
- C. Apply prior to placement of reinforcing steel, anchoring devices, and embedded items.
- D. Do not apply form release agent where concrete surfaces to receive special finishes or applied coverings that are affected by agent. Soak inside surfaces of untreated forms with clean water. Keep surfaces coated prior to placement of concrete.

3.06 INSERTS, EMBEDDED PARTS, AND OPENINGS

- A. Provide formed openings where required for items to be embedded in passing through concrete work.
 - 1. Install accessories in accordance with manufacturer's instructions and referenced standards, level, straight and plumb.
- B. Locate and set in place items that are cast directly into concrete.

- C. Coordinate with work of other sections in forming and placing openings, slots, reglets, recesses, sleeves, bolts, anchors, other inserts, and components of other work.
 - 1. Openings: Size and locate formed openings, depressions, recesses and chases to accommodate products to be applied to, built into and pass through concrete Work. Coordinate size, location and placement of inserts, embedded products, openings and recesses with Work specified in other Sections.
 - 2. Anchors and Other Devices: Set and build into concrete formwork anchorage devices and other embedded products required for Work to be attached to or supported by concrete elements.
 - 3. Locating Embedded Products and Openings: Use setting drawings, diagrams, instructions and templates to set embedded products.
 - 4. Screeds: Set screeds and establish level for tops of concrete slabs and leveling for finish surfaces. Shape surfaces as indicated on the Drawings. Provide cradle, pad or base type screed supports for concrete over waterproof membranes and vapor retarders.
- D. Install accessories in accordance with manufacturer's instructions, so they are straight, level, and plumb. Ensure items are not disturbed during concrete placement.
- E. Provide temporary ports or openings in formwork where required to facilitate cleaning and inspection. Locate openings at bottom of forms to allow flushing water to drain.
- F. Close temporary openings with tight fitting panels, flush with inside face of forms, and neatly fitted so joints are not apparent in exposed concrete surfaces.

3.07 FORM CLEANING

- A. Clean forms as erection proceeds, to remove foreign matter within forms.
- B. Clean formed cavities of debris prior to placing concrete.
 - 1. At above grade forms, flush with water or use compressed air to remove remaining foreign matter. Ensure that water and debris drain to exterior through clean-out ports.
 - 2. During cold weather, remove ice and snow from within forms. Do not use de-icing salts. Do not use water to clean out forms, unless formwork and concrete construction proceed within heated enclosure. Use compressed air or other means to remove foreign matter.
- C. Formwork Reuse: Do not reuse wood and plywood forming materials which contact concrete, except as follows:
 - 1. High density plywood may be cleaned and reused for exposed concrete.
 - 2. Unfaced plywood may be reused for concealed concrete.
 - 3. Steel and fiberglass forming materials may be cleaned and reused.
- D. Patching and Repairs: Patch tie holes with sheet metal patches and restore forms to like new condition prior to reuse.

3.08 FORMWORK TOLERANCES

- A. Construct formwork to maintain tolerances required by ACI 117, unless otherwise indicated.
 - 1. Also as specified in ACI 301, ACI 318, and ACI 347R, unless otherwise specified or indicated.

- B. Camber slabs and beams in accordance with ACI 301.

3.09 FIELD QUALITY CONTROL

- A. An independent testing agency will perform field quality control tests, as specified in Section 01 40 00 - Quality Requirements.
- B. Inspect erected formwork, shoring, and bracing to ensure that work is in accordance with formwork design, and to verify that supports, fastenings, wedges, ties, and items are secure.
 - 1. Comply with CBC Table 1705A.3, item 12.
- C. Do not reuse wood formwork more than 3 times for concrete surfaces to be exposed to view. Do not patch formwork.

3.10 FORM REMOVAL

- A. Do not remove forms or bracing until concrete has gained sufficient strength to carry its own weight and imposed loads.
 - 1. Comply with California Building Code (CBC) requirements.
 - 2. Formwork supporting weight of concrete may not be removed until concrete has reached a minimum of specified 28-day compressive strength and no earlier than 21 days after pour.
 - 3. Removal of Load Bearing Formwork:
 - a. Do not remove shoring and forms supporting weight of concrete, such as beam soffits, joists, slabs, and other structural elements, until concrete has attained its 28 day specified compressive strength, unless otherwise specified or permitted by the Structural Engineer of Record.
 - b. Determine the actual compressive strength has attained is adequate to support the weight of the concrete and superimposed loads.
 - c. Maintain curing and protection operations after form removal.
 - 4. Removal of Non Load Bearing Formwork After Superimposed Loads or as Approved by Engineer:
 - a. Provided that concrete has hardened sufficiently, that it is not damaged, and has achieved sufficient strength to support its own weight and all imposed construction and design loads, forms not actually supporting weight of concrete or weight of soffit forms may be removed after concrete has cured at not less than 50 degrees F for 24 hours.
 - b. Maintain curing and protection operations after form removal.
- B. Loosen forms carefully. Do not wedge pry bars, hammers, or tools against finish concrete surfaces scheduled for exposure to view.
 - 1. Remove formwork progressively so no unbalanced loads are imposed on structure. Remove formwork without damaging concrete surfaces.
 - 2. Remove or snap off metal spreader ties inside wall surface. Cut nails and form ties off flush and leave surfaces level and clean.
- C. Store removed forms to prevent damage to form materials or to fresh concrete. Discard damaged forms.

3.11 PATCHING

- A. Schedule: Patch forming and tie holes immediately after form removal.
- B. Cleaning: Clean surface of all loose materials and soiling.
- C. Patching: Patch all holes and depressions with grouting gun and grout mix of one part cement and 2-1/2 parts mortar sand.

3.12 FORMWORK SCHEDULE

- A. Footings and Walls, Not Exposed to View: Site fabricated plywood or lumber, coated with form release agent.
- B. Footings and Walls, Exposed to View: Site fabricated plywood, coated with form release agent compatible with applied finish coatings.

END OF SECTION

SECTION 03 20 00
CONCRETE REINFORCING

PART 1 GENERAL

1.01 SECTION INCLUDES

- A. Reinforcing steel for cast-in-place concrete.
- B. Supports and accessories for steel reinforcement.

1.02 RELATED REQUIREMENTS

- A. Section 03 10 00 - Concrete Forming and Accessories.
- B. Section 03 30 00 - Cast-in-Place Concrete.
- C. Division 26 - Electrical: Grounding connection to concrete reinforcement.

1.03 REFERENCE STANDARDS

- A. ACI 301 - Specifications for Structural Concrete.
- B. ACI 318 - Building Code Requirements for Structural Concrete and Commentary.
- C. ASTM A615/A615M - Standard Specification for Deformed and Plain Carbon-Steel Bars for Concrete Reinforcement.
- D. ASTM A706/A706M - Standard Specification for Deformed and Plain Low-Alloy Steel Bars for Concrete Reinforcement.
- E. ASTM A996/A996M - Standard Specification for Rail-Steel and Axle-Steel Deformed Bars for Concrete Reinforcement.
- F. ASTM A1064/A1064M - Standard Specification for Carbon-Steel Wire and Welded Wire Reinforcement, Plain and Deformed, for Concrete.
- G. AWS B2.1/B2.1M - Specification for Welding Procedure and Performance Qualification.
- H. AWS A5.5/A5.5M - Specification for Low-Alloy Steel Electrodes for Shielded Metal Arc Welding.
- I. AWS D1.4/D1.4M - Structural Welding Code - Reinforcing Steel.
- J. CRSI (DA4) - Manual of Standard Practice.
- K. CRSI (P1) - Placing Reinforcing Bars.

1.04 SUBMITTALS

- A. See Section 01 30 00 - Administrative Requirements, for submittal procedures.
- B. Product Data:
 - 1. Reinforcement supporting and spacing devices at exposed concrete only, to demonstrate non-corroding and non-staining characteristics.
 - 2. Adhesive compounds.
- C. Manufacturer's Certificate: Certify that reinforcing steel and accessories supplied for this project meet or exceed specified requirements.

- D. Welders' Qualification Statement: Welders' certificates in accordance with AWS B2.1/B2.1M and dated no more than 12 months before start of scheduled welding work.
- E. Reports: Submit certified copies of mill test report of reinforcement materials analysis.
- F. Quality Control Submittals: Submit the following information related to quality assurance requirements specified:
 - 1. Certifications: Submit to the testing laboratory mill test certificates for all reinforcing steel, showing physical and chemical analysis. If steel is to be welded, include in chemical analysis the percentages of carbon, manganese, copper, nickel, and chromium, and optionally the percentages of molybdenum and vanadium.
 - 2. Certifications: If steel is to be welded, submit certifications to the testing laboratory signed by AWS Certified Welding Inspector (CWI) of prequalified welding procedures, qualifications of welding procedures unless prequalified, qualification of welding operators, and qualification of welders.
- G. Welding Procedure Specification Submittal: Submit to Testing Laboratory written Welding Procedure Specifications (WPS) as defined by AWS D1.4/D1.4M. The WPS shall be prepared by the Fabricator for review and approval by the Architect (Structural Engineer) and Testing Laboratory as complying with specified criteria, and shall be readily available to the welding inspector.

1.05 QUALITY ASSURANCE

- A. Perform work of this section in accordance with CRSI (DA4), CRSI (P1), ACI 301, and ACI 318.
 - 1. Maintain one copy of each document on project site.
- B. Regulatory Requirements: Conform to California Building Code (CBC) Title 24 Part 2, Chapter 19A requirements as amended and adopted by authorities having jurisdiction, for details of reinforcement.
- C. Provide Architect, Project Inspector, and Special Inspector with access to fabrication plant to facilitate inspection of reinforcement. Provide notification of commencement and duration of shop fabrication in sufficient time to allow inspection.
- D. Welder Qualifications: Welding processes and welding operators qualified in accordance with AWS D1.4/D1.4M and no more than 12 months before start of scheduled welding work.
 - 1. Only AWS Certified Welding Inspectors shall be used for tests and qualifications associated with welding of reinforcing steel.
 - 2. Only AWS qualified welders or welding operators shall perform welding of reinforcing steel.
- E. Coordinate Work specified in this Section with other Sections which require placement of embedded products and provision of openings and recesses.
- F. If formwork is placed after reinforcement, resulting in insufficient concrete cover over reinforcement, request instructions from Architect (Structural Engineer) before proceeding.

1.06 DELIVERY, STORAGE AND HANDLING

- A. Delivery: Deliver reinforcement bars new and free from rust and mill scale in original bundles marked with durable identification tags.

- B. Storage: Store reinforcement to avoid excessive rusting or fouling with grease, oil, dirt or other bond-weakening coatings.
- C. Handling: Take precautions to maintain reinforcement identification after bundles are broken.

PART 2 PRODUCTS

2.01 REINFORCEMENT

- A. Reinforcing Steel: ASTM A615/A615M, Grade 60 (60,000 psi).
 - 1. Deformed billet-steel bars.
 - 2. Unfinished.
- B. Reinforcing Steel: ASTM A706/A706M, deformed low-alloy steel bars.
 - 1. Unfinished.
 - 2. Carbon Content: 0.55 % maximum.
- C. Reinforcing Steel: #3 Deformed bars, ASTM A615/A615M Grade 40 (280), Type A.
- D. Tie Wire: ASTM A1064/A1064M steel wire, unfinished.
- E. Reinforcement Accessories:
 - 1. Tie Wire: Annealed, minimum 16 gauge, 0.0508 inch.
 - 2. Chairs, Bolsters, Bar Supports, Spacers: Wire-bar-type devices, complying with CRSI (DA4), for spacing, supporting and fastening reinforcing bars and welded wire reinforcement in place. Sized and shaped for adequate support of reinforcement during concrete placement.
 - a. Supports at Slab on Grade: Provide devices with load-bearing pads or horizontal runners where base material does not support chair legs, to prevent puncture of vapor retarder/barrier or provide precast concrete block bar supports of equal or greater strength to specified concrete.
 - b. Corrosion Resistance:
 - 1) Provide stainless steel or plastic components for placement within 1-1/2 inches of weathering surfaces.
 - (a) Provide plastic coated, plastic-tipped (CRSI, Class 1) or stainless steel types at exposed-to-view concrete surfaces.
 - (b) Provide only stainless steel (CRSI Class 2) at exterior exposed surfaces to be painted.
 - 3. Welding Electrodes: AWS A5.5/A5.5M E80XX, low hydrogen, with a minimum yield point of 80,000 psi, for welding grade 60 reinforcing steel.

2.02 RE-BAR SPLICING:

- A. Coupler Systems: Mechanical devices for splicing reinforcing bars; capable of developing 160% of steel reinforcing design strength in tension and compression.
- B. Dowel Bar Splicer with Dowel-Ins: Mechanical devices for connecting dowels; Type II capable of developing 160% of steel reinforcing design strength in tension and compression.
- C. Grout: Cementitious, non-metallic, non-shrink grout for use with manufacturer's grout sleeve reinforcing bar coupler system.

2.03 FABRICATION

- A. Fabricate concrete reinforcing in accordance with CRSI (DA4) - Manual of Standard Practice.
- B. Welding of reinforcement is permitted only with the specific approval of Architect. Perform welding in accordance with AWS D1.4/D1.4M.
- C. Fusion welded reinforcing steel assemblies are not permitted.
- D. Locate reinforcing splices not indicated on drawings at point of minimum stress. See Structural Drawings,
 - 1. Review locations of splices with Architect (Structural Engineer) before fabrication and placement. .

PART 3 EXECUTION

3.01 PREPARATION

- A. Cleaning: Clean reinforcement to remove loose rust and mill scale, soil, and other materials which may reduce or destroy bond with concrete.
- B. Adjustment and Inspection: Do not bend or straighten reinforcement in a manner injurious to material. Do not use bars with kinks or bends not shown on Drawings and reviewed shop drawings, or bars with reduced cross-section due to corrosion or other cause.
- C. Do not bend bars No. 5 and larger in the field.
- D. Do not bend bars more than once in the same location.

3.02 PLACEMENT

- A. General: Place and secure reinforcement as specified herein, as indicated and noted on Drawings and in compliance with recommended details and methods of reinforcement placement and support specified in CRSI Placing Reinforcing Bars.
- B. Place, support and secure reinforcement against displacement. Do not deviate from required position.
 - 1. Set wire ties so ends are directed into concrete, not toward exposed concrete surfaces.
- C. Do not displace or damage vapor barrier.
- D. Accommodate placement of formed openings.
- E. Maintain concrete cover around reinforcing as indicated on Structural Drawings:
- F. Comply with applicable code for concrete cover over reinforcement.
 - 1. If not otherwise indicated on Drawings or specified herein, provide concrete cover in compliance with ACI 318.
- G. Bond and ground all reinforcement to requirements of Division 26.
- H. Coordination: Locate reinforcement to accommodate embedded products and formed openings and recesses.
- I. Slab on Grade Reinforcement: Do not displace or damage vapor retarder/barrier at slab on grade.
- J. Wire Reinforcement Placement: Place reinforcement in sheets as long as practicable, lapping adjoining pieces at least one full mesh and lace splices with 16 gage wire. Offset end laps in

adjacent widths to prevent continuous laps. Extend reinforcement to within 1-inch of edge at slabs on grade. Cut mesh at expansion joints and full depth control joints.

- K. Dowels: Secure tie dowels in place before depositing concrete. Provide No. 3 bars for securing dowels where no other reinforcement is provided.
- L. Reinforcement Splices, General: Provide standard reinforcement splices by lapping ends, placing bars in contact and tightly wire tying. Comply with details and requirements of ACI 318 for minimum lap of spliced bars and criteria indicated on the Drawings.
 - 1. Clearances for Splices: Wherever possible, provide minimum 1-1/2 inch clearance between sets of splices. Stagger horizontal bars so that adjacent splices are minimum 48 inches apart.
- M. Reinforcement Supports: Support reinforcement on metal chairs, spacers or metal hangers to provide required coverage and to properly locate reinforcement. Do not use wood. Avoid cutting or puncturing vapor retarder/barrier during reinforcement placement and concreting operations. Repair damages before placing concrete.
 - 1. Support Spacing: Space chairs and accessories in conformance with CRSI Placing Reinforcing Bars.
- N. Welding of Reinforcement Steel
 - 1. Welding: Perform welding under continuous inspection and supervision of a qualified Registered Deputy Inspector employed by testing and inspection agency. Weld reinforcement as indicated on Drawings.

If mill test report is not available, make chemical analysis of bars representative of bars to be welded. Bars with CE above 0.75 shall not be welded.
 - 2. No welds shall be made at bends in reinforcing bars. Welds to be 1 inch minimum from bends
- O. Corrections During Concrete Placement: Maintain reinforcing steel workers on-site during placement of concrete for resetting reinforcement displaced by runways, workers and other causes.

3.03 FIELD QUALITY CONTROL

- A. An independent testing agency, as specified in Section 01 40 00 - Quality Requirements, will inspect installed reinforcement for compliance with contract documents before concrete placement.
 - 1. Concrete floor slabs on grade are to be continuously inspected as recommended in the geotechnical report.
- B. Inspector of Record, as specified in Section 01 45 33 - Code-Required Special Inspections, will inspect installed reinforcement for conformance to contract documents before concrete placement.
 - 1. Concrete floor slabs on grade are to be continuously inspected as recommended in the geotechnical report.
- C. Defective Reinforcement Work: The following shall be considered defective and may be ordered to be removed and reconstructed at no change in Contract Time or Sum.
 - 1. Bars with kinks or bends not shown on Drawings.
 - 2. Bars injured due to bending or straightening.

3. Bars heated or bent.
4. Reinforcement not placed in accordance with Drawings and Specifications.
5. Rusty or oily bars.
6. Bars exposed in surface of concrete or without adequate concrete cover.

END OF SECTION

SECTION 03 30 00
CAST-IN-PLACE CONCRETE

PART 1 GENERAL

1.01 SECTION INCLUDES

- A. Concrete foundations and anchor bolts.
- B. Joint devices associated with concrete work.
- C. Miscellaneous concrete elements, including equipment pads and thrust blocks.
- D. Concrete curing.

1.02 RELATED REQUIREMENTS

- A. Section 03 10 00 - Concrete Forming and Accessories: Forms and accessories for formwork.
- B. Section 03 20 00 - Concrete Reinforcing.
- C. Section 32 13 13 - Concrete Paving: Sidewalks, curbs and gutters.

1.03 REFERENCE STANDARDS

- A. ACI 211.1 - Standard Practice for Selecting Proportions for Normal, Heavyweight, and Mass Concrete.
- B. ACI 301 - Specifications for Structural Concrete.
- C. ACI 304R - Guide for Measuring, Mixing, Transporting, and Placing Concrete.
- D. ACI 306R - Guide to Cold Weather Concreting.
- E. ACI 308R - Guide to External Curing of Concrete.
- F. ACI 318 - Building Code Requirements for Structural Concrete and Commentary.
- G. ASTM C33/C33M - Standard Specification for Concrete Aggregates.
- H. ASTM C39/C39M - Standard Test Method for Compressive Strength of Cylindrical Concrete Specimens.
- I. ASTM C94/C94M - Standard Specification for Ready-Mixed Concrete.
- J. ASTM C109/C109M - Standard Test Method for Compressive Strength of Hydraulic Cement Mortars (Using 2-in. or (50-mm) Cube Specimens).
- K. ASTM C143/C143M - Standard Test Method for Slump of Hydraulic-Cement Concrete.
- L. ASTM C150/C150M - Standard Specification for Portland Cement.
- M. ASTM C494/C494M - Standard Specification for Chemical Admixtures for Concrete.
- N. ASTM C579 - Standard Test Methods for Compressive Strength of Chemical-Resistant Mortars, Grouts, Monolithic Surfacing, and Polymer Concretes.
- O. ASTM C827/C827M - Standard Test Method for Change in Height at Early Ages of Cylindrical Specimens of Cementitious Mixtures.
- P. ASTM C881/C881M - Standard Specification for Epoxy-Resin-Base Bonding Systems for Concrete.

- Q. ASTM C1059/C1059M - Standard Specification for Latex Agents for Bonding Fresh to Hardened Concrete.
- R. ASTM C1107/C1107M - Standard Specification for Packaged Dry, Hydraulic-Cement Grout (Nonshrink).
- S. ASTM C1602/C1602M - Standard Specification for Mixing Water Used in the Production of Hydraulic Cement Concrete.
- T. ASTM D695 - Standard Test Method for Compressive Properties of Rigid Plastics.
- U. NSF 61 - Drinking Water System Components - Health Effects.
- V. NSF 372 - Drinking Water System Components - Lead Content.

1.04 SUBMITTALS

- A. See Section 01 30 00 - Administrative Requirements for submittal procedures.
- B. Product Data: Submit manufacturers' data on manufactured products showing compliance with specified requirements and installation instructions.
 - 1. Including printed statement of VOC content and material safety data sheets.
- C. Mix Design: Submit proposed concrete mix design.
 - 1. Indicate proposed mix design complies with requirements of ACI 301, Section 4 - Concrete Mixtures.
 - 2. Indicate proposed mix design complies with requirements of ACI 318, Chapter 19 - Concrete: Design and Durability Requirements, and Chapter 26 - Construction Documents and Inspection..
- D. Shop Drawings: Submit proposed layout of construction and control joints for approval.
- E. Test Reports: Submit report for each test or series of tests specified.
- F. Mix Design: Submit mix designs prepared, stamped and signed by a Civil Engineer licensed in the State of California.
- G. Quality Control Submittals:
 - 1. Field tests: Submit reports of all slump, strength and air content tests as required by authorities having jurisdiction and as indicated on the Drawings and specified herein.
 - 2. Delivery tickets: Have available copies of delivery tickets complying with ASTM C94/C94M for each load of concrete delivered to site. Include on the tickets the additional information specified in the ASTM document.
- H. Manufacturer's Installation Instructions: For concrete accessories, indicate installation procedures and interface required with adjacent construction.
- I. Project Record Documents: Accurately record actual locations of embedded utilities and components that are concealed from view upon completion of concrete work.

1.05 QUALITY ASSURANCE

- A. Perform work of this section in accordance with ACI 301 and ACI 318.
 - 1. Maintain one copy of each document on site.
- B. Follow recommendations of ACI 305R when concreting during hot weather .

- C. When air temperature in the shade and away from artificial heat falls below 40 degrees F, or when concrete without special protection is likely to be subject to freezing temperatures before expiration of specified curing period, follow recommendations of ACI 306R when concreting during cold weather.
- D. Regulatory Requirements:
 - 1. Conform to California Building Code (CBC) Chapter 19A requirement, as amended and adopted by authorities having jurisdiction.
 - 2. Chemical products field-applied to concrete shall comply with applicable air quality requirements of authorities having jurisdiction.
 - a. Comply with Section 01 61 16 - Volatile Organic Compound (VOC) Content Restrictions, CALGreen Section 5.504.4 Finish material pollutant control; 5.504.4.1 Adhesives, sealants and caulks; 5.504.4.3 Paints and coatings.
- E. Testing Agency Services: District will engage an independent testing and inspection agency to conduct tests and perform other services specified for quality control during construction, as required by Sections 01 40 00 - Quality Requirements and Section 01 45 33 - Code-Required Special Inspections.
- F. Coordination: Coordinate the placement of joint devices with erection of concrete formwork and placement of form accessories. Coordinate concrete requirements with Work specified for underground utilities and mechanical and electrical equipment pads and bases.

1.06 DELIVERY AND HANDLING

- A. Protection During Concrete Placement: Provide protective coverings and runways, and use appropriate equipment and means of access to Work areas to avoid soiling or damage to existing conditions.
- B. Runoff: Prevent run off of water contaminated by construction agents and chemicals from soiling existing surfaces and from contaminating existing and future landscape areas.

PART 2 PRODUCTS

2.01 FORMWORK

- A. Comply with requirements of Section 03 10 00.

2.02 REINFORCEMENT MATERIALS

- A. Comply with requirements of Section 03 20 00.

2.03 CONCRETE MATERIALS

- A. Cement: ASTM C150/C150M, Type II - Moderate Portland type.
 - 1. Cement used in contact with soil shall be Type V - Sulfate Resistant.
 - 2. Acquire cement for entire project from same source.
- B. Fine and Coarse Aggregates: ASTM C33/C33M.
 - 1. Acquire aggregates for entire project from same source.
 - 2. Fine and coarse aggregates, CBC Title 24, Part 2, and as follows.

- a. Structural Concrete: Maximum size not larger than 1/5 of narrowest dimension between forms, 1/3 depth of slab nor 3/4 of minimum clear spacing between individual reinforcing bars. Maximum aggregate size shall be 1 inch.
- b. Other than Structural Concrete: Conform to requirements for structural concrete.
- C. Water: ASTM C1602/C1602M; clean, potable, and not detrimental to concrete.

2.04 ADMIXTURES

- A. Chemical Admixture:
 - 1. Use no admixtures not included in mix design. Products of the following manufacturers are specified and will be acceptable provided they comply with referenced standards all other requirements of the Contract Documents:
 - a. Manufacturers:
 - 1) BASF Building Systems: www.buildingsystems.basf.com.
 - 2) Dayton Superior Corporation: www.daytonsuperior.com.
 - 3) Euclid Chemical Co.: www.euclidchemical.com.
 - 4) L&M Construction Chemicals, Inc.: www.lmcc.com.
 - 5) Larsen Products Corp.: www.larsenproducts.com.
 - 6) MeadowBurke Co.: meadowburke.com.
 - 7) W.R. Meadows, Inc.: www.wrmeadows.com.
 - 8) Sika Corporation; www.us.sika.com.
 - 9) Simpson Strong-Tie: www.strongtie.com
 - 10) Specialty Products Group: www.SPGoGreen.com.
 - 11) US Spec Division of US Mix Products Co.: www.usspec.com.
 - 12) Substitutions: See Section 01 60 00 - Product Requirements.
- B. Do not use chemicals that result in soluble chloride ions in excess of 0.1 percent by weight of cement.
- C. Water Reducing and Accelerating Admixture: ASTM C494/C494M Type E.
 - 1. Manufacturers:
 - a. Euclid Chemical Company; ACCELGUARD 80: www.euclidchemical.com/#sle.
 - b. Accelguard 80 by Euclid Chemical Co.
 - c. Pozzutec 20 by Master Builders Technology, Inc.
 - d. Substitutions: See Section 01 60 00 - Product Requirements.
- D. Water Reducing and Retarding Admixture: ASTM C494/C494M Type D.
 - 1. Manufacturers:
 - a. L.M. Scofield Company: www.scofield.com.
 - b. Eucon Retarder 75 by Euclid Chemical Co.
 - c. Pozzolite R by Master Builders Technology, Inc.
 - d. Plastiment by Sika Corporation.
 - e. Substitutions: See Section 01 60 00 - Product Requirements.
- E. Water Reducing Admixture: ASTM C494/C494M Type A.
 - 1. Manufacturers:
 - a. Euclid Chemical Company; EUCON NW: www.euclidchemical.com/#sle.

- b. Eucon WR-75 by Euclid Chemical Co.
- c. Pozzolith Normal or Polyheed by Master Builders Technology, Inc.
- d. Plastocrete 161 by Sika Corporation.
- e. Substitutions: See Section 01 60 00 - Product Requirements.

2.05 ACCESSORY MATERIALS

- A. Non-Shrink Cementitious Grout: Premixed compound consisting of non-metallic aggregate, cement, water reducing and plasticizing agents.
 - 1. Grout: Comply with ASTM C1107/C1107M.
 - 2. Height Change, Plastic State; when tested in accordance with ASTM C827/C827M:
 - a. Maximum: Plus 4 percent.
 - b. Minimum: Plus 1 percent.
 - 3. Minimum Compressive Strength at 48 Hours: 2,000 pounds per square inch.
 - 4. Minimum Compressive Strength at 28 Days: 8,000 pounds per square inch.
 - 5. Flowable Products:
 - a. Dayton Superior Corporation: www.daytonsuperior.com/#sle.
 - b. L&M Construction Chemicals, Inc, a subsidiary of Laticrete International, Inc; DURAGROUT: www.laticrete.com/our-products/concrete-construction-chemicals/#sle.
 - c. Sika Corporation; SikaGrout 328: www.us.sika.com.
 - d. SpecChem, LLC; SC Precision Grout: www.specchemllc.com/#sle.
 - e. US SPEC; MP Grout: www.usspec.com.
 - f. W. R. Meadows, Inc; 588-10K: www.wrmeadows.com/#sle.
 - g. W. R. Meadows, Inc; 1428 HP: www.wrmeadows.com/#sle.
 - h. Substitutions: See Section 01 60 00 - Product Requirements.
 - 6. Low-Slump, Dry Pack Products:
 - a. Dayton Superior Corporation; Dri Pak Precast Grout: www.daytonsuperior.com/#sle.
 - b. L&M Construction Chemicals, Inc, a subsidiary of Laticrete International, Inc; Duragrout: www.lmcc.com/#sle.
 - c. Sika Corporation; SikaGrout 212: www.us.sika.com.
 - d. US SPEC; GP Grout: www.usspec.com.
 - e. Substitutions: See Section 01 60 00 - Product Requirements.
 - B. Non-Shrink Epoxy Grout: Moisture-insensitive, two-part; consisting of epoxy resin, non-metallic aggregate, and activator.
 - 1. Composition: High solids content material exhibiting positive expansion when tested in accordance with ASTM C827/C827M.
 - a. Maximum Height Change: Plus 4 percent.
 - b. Minimum Height Change: Plus 1 percent.
 - 2. Minimum Compressive Strength at 7 days, ASTM C579: 12,000 pounds per square inch.
- OR

3. Minimum Compressive Strength at 7 days, ASTM D695: 12,000 pounds per square inch.
4. Manufacturers:
 - a. Euclid Chemical Company; E3-DEEP POUR: www.euclidchemical.com/#sle.
 - b. Dayton Superior Corporation: www.daytonsuperior.com/#sle.
 - c. Euclid Chemical Co.; www.euclidchemical.com.
 - d. Five Star Products, Inc; Five Star DP Epoxy Grout: www.fivestarprouducts.com.
 - e. L&M Construction Chemicals, Inc.; www.lmcc.com.
 - f. Sika Corporation; Sika Grout Pak 42: www.us.sika.com.
 - g. SpecChem, LLC; SpecPoxy Grout: www.specchemllc.com.
 - h. US Mix Products Co.; www.usspec.com.
 - i. W.R. Meadows, Inc.; REZI-WELD 3/2: www.wrmeadows.com.
 - j. Substitutions: See Section 01 60 00 - Product Requirements.

2.06 BONDING AND JOINTING PRODUCTS

- A. Latex Bonding Agent: Non-redispersable acrylic latex, complying with ASTM C1059/C1059M, Type II.
 1. Acrylic or Styrene Butadiene:
 2. Manufacturers:
 - a. BASF Building Systems; MasterEmaco A 400 or A 600: www.buildingsystems.basf.com.
 - b. Dayton Superior Corp.; Acrylic Bonding Agent J40: www.daytonsuperior.com
 - c. Euclid Chemical Company; AKKRO-7T: www.euclidchemical.com/#sle.
 - d. L&M Construction Chemicals, Inc.; Everbond: www.lmcc.com.
 - e. MeadowBurke Co.; Arcylic Bond: meadowburke.com.
 - f. Sika Corporation; Sika Latex by Sika Corporation: www.us.sika.com.
 - g. Simpson Strong-Tie; FX-Bondcrete: www.strongtie.com
 - h. SpecChem, LLC; Strong Bond Acrylic Bonder: www.specchemllc.com/#sle.
 - i. W. R. Meadows, Inc; ACRY-LOK-: www.wrmeadows.com/#sle.
 - j. US Spec Division of US Mix Products Co.; Acrylcoat, Dura: www.usspec.com.
 - k. Substitutions: See Section 01 60 00 - Product Requirements.
- B. Epoxy Bonding System:
 1. Complying with ASTM C881/C881M and of Type required for specific application.
 2. Manufacturers:
 - a. Adhesives Technology Corporation; Crackbond SLV-302, Crackbond LR-321, Crackbond LR-321 LPL, Ultrabond 2100 LPL, Ultrabond 2100, Ultrabond 1, Ultrabond 2, or Ultrabond HS200: www.atcepoxy.com/#sle.
 - b. Euclid Chemical Company; DURAL FAST SET LV: www.euclidchemical.com/#sle.
 - c. Euclid Chemical Company; DURALFLEX GEL: www.euclidchemical.com/#sle.
 - d. Euclid Chemical Company; DURALFLEX LV: www.euclidchemical.com/#sle.
 - e. Euclid Chemical Company; DURAL 452 GEL, DURAL 452 LV, or DURAL 452 MV: www.euclidchemical.com/#sle.

- f. Dayton Superior Corporation; Slow Set Bonding Agent: www.daytonsuperior.com/#sle.
 - g. Sika Corporation; Sikadur 31 Hi Mod Gel or Sikadur 32 Hi Mod Bonder: www.us.sika.com.
 - h. Simpson Strong-Tie; FX-752 Epoxy Bonding Agent, FX-762 High-Modulus Epoxy Bonding Agent, FX-792LPL Long Pot Life Epoxy Bonding Agent: www.strongtie.com
 - i. SpecChem, LLC; SpecPoxy 1000, SpecPoxy 2000, SpecPoxy 3000, or SpecPoxy 3000FS: www.specchemllc.com/#sle.
 - j. W. R. Meadows, Inc; Rezi-Weld Gel Paste, Rezi-Weld Gel Paste State, Rezi-Weld 1000: www.wrmeadows.com/#sle.
 - k. Substitutions: See Section 01 60 00 - Product Requirements.
- C. Waterstops: Bentonite and butyl rubber, complying with NSF 61 and NSF 372.

2.07 CURING MATERIALS

- A. Evaporation Reducer: Liquid thin-film-forming compound that reduces rapid moisture loss caused by high temperature, low humidity, and high winds; intended for application immediately after concrete placement.
- 1. Manufacturers:
 - a. Atlas Tech Products Division of Atlas Construction Supply, Inc.;; Atlas Finish-Film: www.atlastechproducts.com.
 - b. Dayton Superior Corporation; AquaFilm Concentrate J74: www.daytonsuperior.com/#sle.
 - c. Euclid Chemical Company ; EUCOBAR: www.euclidchemical.com/#sle.
 - d. Nox-Crete Inc; Monofilm: www.nox-crete.com/#sle.
 - e. Master Builder Solutions by BASF; MasterKure ER 50: www.master-builders-solutions.basf.us.
 - f. Nox-Crete Products Group; Monofilm: www.nox-crete.com
 - g. Sika Corp.; SikaFilm: usa.sika.com.
 - h. SpecChem, LLC; SpecFilm Concentrate or SpecFilm: www.specchemllc.com/#sle.
 - i. W. R. Meadows, Inc ; Evapre or Evapre-RTU: www.wrmeadows.com/#sle.
 - j. Substitutions: See Section 01 60 00 - Product Requirements.
- B. Curing Compound, Naturally Dissipating: Clear, water-based, liquid membrane-forming compound; complying with ASTM C309.
- 1. Application: Use at concrete slab on grade.
 - 2. Product dissipates within 4 to 6 weeks.
 - 3. Provide product containing fugitive red dye.
 - 4. Manufacturers:
 - a. Dayton Superior Corporation: www.daytonsuperior.com/#sle.
 - b. Euclid Chemical Company; COLOR-CRETE CURE AND SEAL VOC: www.euclidchemical.com/#sle.
 - c. SpecChem, LLC; SpecRez: www.specchemllc.com/#sle.
 - d. Paul M. Wolff Co.; SHUR-CURE: www.paulwolffco.com.

- e. W. R. Meadows, Inc; 1100-Clear: www.wrmeadows.com/#sle.
 - f. Substitutions: See Section 01 60 00 - Product Requirements.
- C. Water: Potable, not detrimental to concrete.

2.08 CONCRETE MIX DESIGN

- A. Mix Design: Contractor shall coordinate with the Testing Laboratory of Record, under supervision of Civil Engineer licensed in the State of California, to determine mix proportions to fulfill specified requirements for strength, aggregate, size and workability of concrete.
- B. Proportioning Normal Weight Concrete: Comply with ACI 211.1 recommendations.
 - 1. Comply with Chapter 19A requirements.
- C. Concrete Strength: Establish required average strength for each type of concrete on the basis of field experience or trial mixtures, as specified in ACI 301.
 - 1. For trial mixtures method, employ independent testing agency acceptable to Architect for preparing and reporting proposed mix designs.
- D. Admixtures: Add acceptable admixtures as recommended in ACI 211.1 and at rates recommended or required by manufacturer.
- E. Normal Weight Concrete:
 - 1. Compressive Strength, when tested in accordance with ASTM C39/C39M at 28 days: As indicated on Structural Drawings.
 - 2. Proportions: For normal weight concrete, in accordance with ACI 301, and as noted on the Drawings.
 - 3. Structural Concrete: Structural concrete strengths (including non-structural floor slabs on grade), aggregate sizes and slumps indicated on Structural Drawings.
 - 4. Water-Cement Ratio: As indicated on Structural Drawings.
 - 5. Maximum Slump: As indicated on Structural Drawings.
 - 6. Maximum Aggregate Size: As indicated on Structural Drawings.

2.09 MIXING

- A. Transit Mixers: Comply with ASTM C94/C94M.
- B. Adding Water: If concrete arrives on-site with slump less than suitable for placement, do not add water that exceeds the maximum water-cement ratio or exceeds the maximum permissible slump.

PART 3 EXECUTION

3.01 EXAMINATION

- A. Verify lines, levels, and dimensions before proceeding with work of this section.
- B. Verify that concrete cover requirements are met in formwork construction and reinforcement placement.
- C. Verify that all embedded products and formed openings and recesses are correctly placed.

3.02 PREPARATION

- A. Verify that forms are clean and free of rust before applying release agent.
- B. Prepare previously placed concrete by cleaning with hydro-blasting or wet sand blasting to provide suitable surface for bonding. Provide minimum aggregate exposure of 1/4 inch.
- C. Coordinate placement of embedded items with erection of concrete formwork and placement of form accessories.
- D. Where new concrete is to be bonded to previously placed concrete, prepare existing surface by cleaning and applying bonding agent in accordance with bonding agent manufacturer's instructions.
 - 1. Use epoxy bonding system for bonding to damp surfaces, for structural load-bearing applications, and where curing under humid conditions is required.
 - 2. Use latex bonding agent only for non-load-bearing applications.

3.03 CONCRETE MIXING

- A. Concrete Mixing, General: Comply with ACI 318 as adopted by CBC, Title 24, Part 2, Chapter 19A and ACI 304R - Guide for Measuring, Mixing, Transporting, and Placing Concrete. Introduce and mix admixtures in compliance with manufacturer's instructions and recommendations.

3.04 PLACING CONCRETE

- A. Notify District's Inspector and DSA at least 2 working days in advance of placing concrete.
- B. Place concrete in accordance with ACI 304R. General: Comply with ACI 318 as adopted by CBC, Title 24, Part 2, Chapter 19A and as follows:
 - 1. Schedule continuous placement of concrete to prevent the formation of cold joints.
 - 2. Ready mix concrete shall be delivered in accordance with ASTM C94/C94M. Concrete shall be placed within 90 minutes after start of mixing.
 - 3. Provide construction joints if concrete for a particular element or component cannot be placed in a continuous operation.
 - a. Submit for review, proposed locations of joints prior to pouring. See Structural Drawings for additional requirements.
 - 4. Deposit concrete as close as possible to its final location, to avoid segregation.
- C. Placement in Forms: Limit horizontal layers to depths which can be properly consolidated, but in no event greater than 24 inches.
 - 1. Consolidate concrete by means of mechanical vibrators, inserted vertically in freshly placed concrete in a systematic pattern at close intervals. Penetrate previously placed concrete to ensure that separate concrete layers are knitted together.
 - 2. Vibrate concrete sufficiently to achieve consistent consolidation without segregation of coarse aggregates.
 - 3. Do not use vibrators to move concrete laterally.
- D. Notify Architect not less than 48 hours prior to commencement of placement operations.
- E. Ensure reinforcement, inserts, and waterstops are not disturbed during concrete placement.

- F. Place concrete continuously without construction (cold) joints wherever possible; where construction joints are necessary, before next placement prepare joint surface by removing laitance and exposing the sand and sound surface mortar, by sandblasting or high-pressure water jetting.

3.05 CONCRETE FINISHING

- A. Repair surface defects, immediately after removing formwork.
 - 1. Remove honeycombed areas and other defective concrete down to sound concrete, cutting perpendicular to surface or slightly undercutting without damaging reinforcement. Dampen patch location and area immediately surrounding it prior to applying bonding compound or patching mortar.
 - 2. Before bonding compound has dried, apply patching mixture matching original concrete in materials and mix except for omission of coarse aggregate, and using a blend of white and normal portland cement as necessary to achieve color match. Consolidate thoroughly and strike off slightly higher than surrounding surface.

3.06 CURING AND PROTECTION

- A. Comply with requirements of ACI 308R. Immediately after placement, protect concrete from premature drying, excessively hot or cold temperatures, and mechanical injury.
- B. Maintain concrete with minimal moisture loss at relatively constant temperature for period necessary for hydration of cement and hardening of concrete.
 - 1. Normal concrete: Not less than seven days.
- C. Formed Surfaces: Cure by moist curing with forms in place for full curing period.
- D. Surfaces Not in Contact with Forms:
 - 1. Initial Curing: Start as soon as free water has disappeared and before surface is dry. Keep continuously moist for not less than three days by water-fog spray or saturated burlap.
 - a. Spraying: Spray water over floor slab areas and maintain wet.
 - b. Saturated Burlap: Saturate burlap-polyethylene and place burlap-side down over floor slab areas, lapping ends and sides; maintain in place.
 - 2. Final Curing: Begin after initial curing but before surface is dry.
 - a. Moisture-Retaining Sheet: Lap strips not less than 3 inches and seal with waterproof tape or adhesive; secure at edges.
 - b. Curing Compound: Apply in two coats at right angles, using application rate recommended by manufacturer.

3.07 MISCELLANEOUS CONCRETE ITEMS

- A. Filling In: Fill in holes and openings left in concrete structures for passage of Work specified in other Sections, after such Work is in place. Mix, place, and cure concrete as specified to blend with in-place construction. Provide other miscellaneous concrete filling shown or required to complete Work. Use non-shrink grout where required or indicated.
- B. Equipment Bases and Foundations: Provide machine and equipment bases and foundations as shown on drawings. Set anchor bolts for machines and equipment to template at correct

elevations, complying with diagrams or templates of manufacturer furnishing machines and equipment.

3.08 FIELD QUALITY CONTROL

- A. An independent testing agency will perform field quality control tests, as specified in Section 01 40 00 - Quality Requirements.
- B. Provide free access to concrete operations at project site and cooperate with appointed firm.
- C. Submit proposed mix design of each class of concrete to inspection and testing firm for review prior to commencement of concrete operations.
- D. Field Certifications: For all concrete, provide signed copy of batch plant's certificate stating quantity of each material, amount of water, admixtures, departure time and date accompanying each load of materials or concrete.
- E. Field Tests of Concrete: Perform tests in accordance with applicable California Building Code requirements, ACI 301 and requirements of authorities having jurisdiction.
- F. Tests of concrete and concrete materials may be performed at any time to ensure conformance with specified requirements.
- G. Compressive Strength Tests: ASTM C39/C39M. For each test, mold and cure four concrete test cylinders. Obtain test samples for every 2,000 sq ft - 50 cu yd or less of slab and structural concrete of each class of concrete placed (CBC requirement).
 - 1. Test one cylinder at 7 days and two at 28 days after placement.
 - 2. Maintain fourth cylinder to be tested at 56 days only if 28-day test fails to meet strength requirement.
 - 3. Take one additional test cylinder during cold weather concreting and cure it at job site under same conditions as concrete it represents. Test cold weather cylinder at 28 days.
- H. Take one additional test cylinder during cold weather concreting, cured on job site under same conditions as concrete it represents.
- I. Perform one slump test for each set of test cylinders taken, following procedures of ASTM C143/C143M.

3.09 DEFECTIVE CONCRETE

- A. Test Results: The testing agency shall report test results in writing to Architect and Contractor within 24 hours of test.
- B. Defective Concrete: Concrete not complying with required lines, details, dimensions, tolerances or specified requirements.
- C. Repair or replacement of defective concrete will be determined by the Architect. The cost of additional testing shall be borne by Contractor when defective concrete is identified.
 - 1. Obtain repair details from Architect (Structural Engineer) and approved by DSA before proceeding.
- D. Do not patch, fill, touch-up, repair, or replace exposed concrete except upon express direction of Architect for each individual area.

3.10 PROTECTION

- A. Do not permit traffic over unprotected concrete floor surface until fully cured.

- B. Protect concrete from marring and damage due to weather and construction activities.
 - 1. Protective measures shall include providing temporary coverings, and be in accordance with Section 01 50 00 - Temporary Facilities and Controls, and shall prohibit all non-essential construction activities, including cleaning and maintenance of construction equipment.
 - 2. In particular, protect concrete floor slabs from oil, paint and other products that might penetrate and degrade concrete surface.

END OF SECTION

SECTION 04 05 11
MASONRY MORTARING AND GROUTING

PART 1 GENERAL

1.01 SECTION INCLUDES

- A. Mortar for masonry.
- B. Grout for masonry.

1.02 RELATED REQUIREMENTS

- A. Section 04 20 00 - Unit Masonry: Installation of mortar and grout.

1.03 REFERENCE STANDARDS

- A. TMS 402/602 - Building Code Requirements and Specification for Masonry Structures.
- B. ASTM C91/C91M - Standard Specification for Masonry Cement.
- C. ASTM C94/C94M - Standard Specification for Ready-Mixed Concrete.
- D. ASTM C270 - Standard Specification for Mortar for Unit Masonry.
- E. ASTM C387/C387M - Standard Specification for Packaged, Dry, Combined Materials for Concrete and High Strength Mortar.
- F. ASTM C476 - Standard Specification for Grout for Masonry.
- G. ASTM C780 - Standard Test Method for Preconstruction and Construction Evaluation of Mortars for Plain and Reinforced Unit Masonry.
- H. ASTM C1019 - Standard Test Method for Sampling and Testing Grout for Masonry.
- I. ASTM C1142 - Standard Specification for Extended Life Mortar for Unit Masonry.

1.04 SUBMITTALS

- A. See Section 01 30 00 - Administrative Requirements, for submittal procedures.
- B. Product Data: Include design mix and indicate whether the Proportion or Property specification of ASTM C270 is to be used. Also include required environmental conditions and admixture limitations.
- C. Reports: Submit reports on mortar indicating compliance of mortar to property requirements of ASTM C270 and test and evaluation reports per ASTM C780.
- D. Reports: Submit reports on grout indicating compliance of component grout materials to requirements of ASTM C476 and test and evaluation reports to requirements of ASTM C1019.
- E. Manufacturer's Certificate: Certify that products meet or exceed specified requirements.
- F. Manufacturer's Installation Instructions: Submit packaged dry mortar manufacturer's installation instructions.

1.05 QUALITY ASSURANCE

- A. Comply with provisions of TMS 402/602, except where exceeded by requirements of Contract Documents.
 - 1. Maintain one copy of each document on project site.

1.06 DELIVERY, STORAGE, AND HANDLING

- A. Maintain packaged materials clean, dry, and protected against dampness, freezing, and foreign matter.

1.07 FIELD CONDITIONS

- A. Cold and Hot Weather Requirements: Comply with requirements of TMS 402/602 or CBC Chapter 21A building code, whichever is more stringent.

PART 2 PRODUCTS

2.01 MORTAR AND GROUT APPLICATIONS

- A. Use only factory premixed packaged dry materials for mortar and grout, with addition of water only at project site.
 - 1. Exception: If a specified mix design is not available in a premixed dry package, provide equivalent mix design using standard non-premixed materials.
- B. Mortar Color: Natural gray unless otherwise indicated.
- C. Mortar Mix Designs: ASTM C270, Proportion Specification.
 - 1. Masonry below grade and in contact with earth: Type S.
 - 2. Exterior, Non-loadbearing Masonry: Type S.
 - 3. Interior, Loadbearing Masonry: Type S.
- D. Grout Mix Designs:
 - 1. Comply with CBC 2103A.3.1.
 - 2. Engineered Masonry: Compressive strength at 28 days: as indicated on Drawings; 8-10 inches slump; provide premixed type in accordance with ASTM C 94/C 94M.
 - a. Fine grout for spaces with smallest horizontal dimension of 2 inches or less.
 - b. Coarse grout for spaces with smallest horizontal dimension greater than 2 inches.

2.02 MATERIALS

- A. All materials to conform to CBC, Section 2103A.2 and 2103A.3.
- B. Packaged Dry Material for Mortar for Unit Masonry: Premixed Portland cement, hydrated lime, and sand; complying with ASTM C387/C387M and capable of producing mortar of the specified strength in accordance with ASTM C270 with the addition of water only.
 - 1. Type: Type S.
 - 2. Color: Standard gray.
- C. Packaged Dry Material for Grout for Masonry: Premixed cementitious materials and dried aggregates; capable of producing grout of the specified strength in accordance with ASTM C476 with the addition of water only.
 - 1. Type: Fine.
- D. Water: Clean and potable.
- E. Bonding Agent: Latex type.

2.03 MORTAR MIXING

- A. Ready Mixed Mortar: ASTM C1142, Type equivalent to that specified according to ASTM C270.
- B. Thoroughly mix mortar ingredients using mechanical batch mixer, in accordance with ASTM C270 and in quantities needed for immediate use.
- C. Maintain sand uniformly damp immediately before the mixing process.
- D. Do not use anti-freeze compounds to lower the freezing point of mortar.
- E. If water is lost by evaporation, re-temper only within two hours of mixing.

2.04 GROUT MIXING

- A. Mix grout in accordance with ASTM C94/C94M.
- B. Thoroughly mix grout ingredients in quantities needed for immediate use in accordance with ASTM C476 for fine and coarse grout.
 - 1. Per DSA IR 21-2.13, revised 3/3/16 (modified for 2016 CBC):
 - a. The grout mix shall comply with the requirements of CBC, Section 2103A.3.
 - 1) All cells shall be solidly filled with grout in reinforced hollow unit masonry per CBC Section 2104A.1.3.
 - 2) A coarse grout shall be used in grout spaces 2 inches or more in width and in all grouted cells of hollow unit masonry, per CBC Section 2103A.3.
 - b. Sufficient water may be added to make a workable mix that will flow into all voids of the masonry without separation or segregation.
 - 1) The slump of the grout shall be 8 to 11 inches per TMS 402/602, Article 2.6 B.2 and ASTM C476, Section 4.2.2.
 - c. Grout mixes shall contain an approved admixture conforming to the requirements of this specification. Admixture shall be used in strict accordance with the manufacturer's instructions and appropriate listing from ICC-ES or other acceptable evaluation agency per IR A-5.
- C. Add admixtures in accordance with manufacturer's instructions; mix uniformly.
 - 1. Basis of Design Product: Grout Aid as manufactured by Sika, or approved equal.
 - 2. Admixtures shall meet the requirements of CBC Section 2103A.5 and have an evaluation report meeting the requirements of IR A-5.
 - 3. The approval of the Architect or structural engineer and DSA is required for the use of any admixture.

PART 3 EXECUTION

3.01 PREPARATION

- A. Apply bonding agent to existing concrete surfaces.
- B. Plug clean-out holes for grouted masonry with block masonry units. Brace masonry to resist wet grout pressure.

3.02 INSTALLATION

- A. Install mortar and grout to requirements of section(s) in which masonry is specified.
- B. Do not install grout in lifts greater than 16 inches without consolidating grout by rodding.

3.03 GROUTING

- A. Perform all grouting by means of low-lift technique. Do not employ high-lift grouting.
- B. Low-Lift Grouting:
 - 1. Limit height of pours to 48 inches.
 - 2. Limit height of masonry to 16 inches above each pour.
 - 3. Pour grout only after vertical reinforcing is in place; place horizontal reinforcing as grout is poured. Prevent displacement of bars as grout is poured.
 - 4. Place grout for each pour continuously and consolidate immediately; do not interrupt pours for more than 1-1/2 hours.
- C. When grouting is stopped for more than one hour, terminate grout minimum 1-1/2 inch, 2 inches maximum below top of upper masonry unit to form a positive key for subsequent grout placement.
- D. Solid grout all cells and courses, no exceptions. Consolidate with 3/4 inch diameter mechanical vibrator inserted into each and every cell.

3.04 FIELD QUALITY CONTROL

- A. An independent testing agency will perform field tests, in accordance with provisions of Section 01 40 00 - Quality Requirements.
- B. Testing of mortar and grout: Conform to the requirements of CBC, Section 2105A.3.
- C. Test and evaluate mortar in accordance with ASTM C780 procedures.
 - 1. Test with same frequency as specified for masonry units.
- D. Test and evaluate grout in accordance with ASTM C1019 procedures.
 - 1. Test with same frequency as specified for masonry units.

END OF SECTION

SECTION 04 20 00
UNIT MASONRY

PART 1 GENERAL

1.01 SECTION INCLUDES

- A. Concrete block.
- B. Reinforcement and anchorage.
- C. Accessories.

1.02 RELATED REQUIREMENTS

- A. Section 03 20 00 - Concrete Reinforcing: Reinforcing steel for grouted masonry.
- B. Section 04 05 11 - Masonry Mortaring and Grouting.
- C. Section 05 50 00 - Metal Fabrications: fabricated steel items.
- D. Section 07 92 00 - Joint Sealants: Sealing control and expansion joints.

1.03 REFERENCE STANDARDS

- A. ASTM C90 - Standard Specification for Loadbearing Concrete Masonry Units.
- B. ASTM C129 - Standard Specification for Nonloadbearing Concrete Masonry Units.
- C. TMS 402/602 - Building Code Requirements and Specification for Masonry Structures.
- D. DSA, Interpretation of Regulations Document IR 21-2.13 - Concrete Masonry High Lift Grouting Method; 3/03/16.

1.04 ADMINISTRATIVE REQUIREMENTS

- A. Preinstallation Meeting: Convene a preinstallation meeting one week before starting work of this section; require attendance by all relevant installers.

1.05 SUBMITTALS

- A. See Section 01 30 00 - Administrative Requirements, for submittal procedures.
- B. Product Data: Provide data for masonry units and masonry accessories.
- C. Samples: Submit four samples of decorative block units to illustrate color, texture, and extremes of color range.
- D. Manufacturer's Certificate: Certify that masonry units meet or exceed specified requirements.
- E. Test Reports: Concrete masonry manufacturer's test reports for units with integral water repellent admixture.
- F. Installer's Qualification Statement.
- G. Maintenance Materials: Furnish the following for District's use in maintenance of project.
 - 1. See Section 01 60 00 - Product Requirements, for additional provisions.

1.06 QUALITY ASSURANCE

- A. Comply with provisions of TMS 402/602, except where exceeded by requirements of Contract Documents.
 - 1. Maintain one copy of each document on project site.
- B. Regulatory Requirements: Except as modified by the requirements specified herein or the details indicated, reinforced concrete unit masonry construction shall conform to the California Building Code (CBC), Title 24, Part 2, Chapter 21A - Masonry.
- C. Manufacturer Qualifications: Company specializing in manufacturing the type of products specified in this section with minimum three years of documented experience.
- D. Installer Qualifications: Company specializing in performing work of the type specified and with at least three years of documented experience.
- E. Single-Source Responsibility for Masonry Units: Obtain exposed masonry units of uniform texture and color, or a uniform blend within the ranges accepted for these characteristics, from one manufacturer for each different product required for each continuous surface or visually related surfaces.

1.07 DELIVERY, STORAGE, AND HANDLING

- A. Deliver, handle, and store masonry units by means that will prevent mechanical damage and contamination by other materials.
 - 1. Store and handle masonry units off the ground, under cover, and in a dry location to prevent their deterioration or damage due to moisture, temperature changes, contaminants, corrosion, and other causes. If units become wet, do not place until units are in an air-dried condition.

PART 2 PRODUCTS

2.01 CONCRETE MASONRY UNITS

- A. Acceptable Manufacturers:
 - 1. Angeles Block Co., Inc.: www.angelusblock.com.
 - 2. Orco Block Co.: www.orco.com.
 - 3. RCP Block and Brick: www.rcpblock.com.
 - 4. Substitutions: See Section 01 60 00 - Product Requirements.
- B. Concrete Block: Comply with referenced standards and as follows:
 - 1. Size: Standard units with nominal face dimensions of 16 x 8 inches or as indicated and nominal depths as indicated on the Drawings for specific locations.
 - 2. Special Shapes: Provide non-standard blocks configured for corners, lintels, headers, control joint edges, and other detailed conditions.
 - 3. Load-Bearing Units: ASTM C90, medium weight.
 - a. Hollow block, as indicated.
 - b. Exposed Faces: Manufacturer's standard color and texture where indicated.
 - c. Pattern: As indicated on Drawings.

- d. Unit Compressive Strength: Where indicated, provide units with minimum average net area compressive strength of 2,000 psi (Type M or S) and not less than the unit compressive strengths required to produce concrete unit masonry construction of compressive strength indicated.
- e. Non-Loadbearing Units: ASTM C129.
 - 1) Hollow block, as indicated.
 - 2) Medium weight.
- f. Solid Cap Unit: Nominal unit size, texture and color to match adjacent wall, unless specified otherwise.

2.02 MORTAR AND GROUT MATERIALS

- A. Mortar and Grout: As specified in Section 04 05 11.

2.03 REINFORCEMENT AND ANCHORAGE

- A. Reinforcing Steel: Type specified in Section 03 20 00; size as indicated on drawings; uncoated finish.

2.04 ACCESSORIES

- A. Preformed Control Joints: Neoprene material. Provide with corner and tee accessories, fused joints.
 - 1. Manufacturers:
 - a. Blok-Lok Limited: www.blok-lok.com/#sle.
 - b. Dur-O-Wal: www.dur-o-wal.com.
 - c. Hohmann & Barnard, Inc: www.h-b.com.
 - d. WIRE-BOND: www.wirebond.com/#sle.
 - e. Substitutions: See Section 01 60 00 - Product Requirements.
- B. Joint Filler: Closed cell polyurethane; oversized 50 percent to joint width; self expanding; 3/8 inch wide by maximum lengths available.
 - 1. Manufacturers:
 - a. Hohmann & Barnard, Inc: www.h-b.com.
 - b. WIRE-BOND: www.wirebond.com/#sle.
 - c. Substitutions: See Section 01 60 00 - Product Requirements.
- C. Cleaning Solution: Non-acidic, not harmful to masonry work or adjacent materials.
 - 1. Job-Mixed Detergent Solution: Solution of trisodium phosphate (1/2-cup dry measure) and laundry detergent (1/2-cup dry measure) dissolved in one gallon of water.
 - 2. Basis of Design Product: Enviro Klean as manufactured by ProSoCo, Inc., www.prosoco.com, or equal.

PART 3 EXECUTION

3.01 EXAMINATION

- A. Verify that field conditions are acceptable and are ready to receive masonry.
- B. Verify that related items provided under other sections are properly sized and located.

- C. Verify that built-in items are in proper location, and ready for roughing into masonry work.

3.02 PREPARATION

- A. Direct and coordinate placement of metal anchors supplied for installation under other sections.
- B. Comply with CBC Section 2104A in addition to referenced unit masonry standard and other requirements indicated applicable to each type of installation included in Project.
- C. Cut or trim interior of face shells or cross webs of masonry units, where necessary, to provide a minimum clearance of 1/2 inch or one bar diameter, whichever is greater, to reinforcing bars.
- D. Protection of Unit Masonry: During erection, cover tops of walls, projections, and sills with waterproof sheeting at end of each workday. Cover partially completed unit masonry when construction is not in progress.
 - 1. Extend cover a minimum of 24-inches down both sides and hold cover securely in place.
- E. Stain Prevention: Prevent grout, mortar, and soil from staining the face of unit masonry to be left exposed or painted. Remove immediately any grout, mortar, and soil that come in contact with such masonry.
- F. Stopping and Resuming Work: In each course, rack back 1/2-unit length for one-half running bond; do not tooth. Clean exposed surfaces of set masonry, and remove loose masonry units and mortar prior to laying fresh masonry.

3.03 COLD AND HOT WEATHER REQUIREMENTS

- A. Comply with requirements of TMS 402/602 or applicable building code, whichever is more stringent.

3.04 COURSING

- A. Establish lines, levels, and coursing indicated. Protect from displacement.
- B. Maintain masonry courses to uniform dimension. Form vertical and horizontal joints of uniform thickness.
- C. Concrete Masonry Units:
 - 1. Bond: Running.
 - 2. Coursing: One unit and one mortar joint to equal 8 inches.
 - 3. Mortar Joints: Concave.

3.05 PLACING AND BONDING

- A. Lay out walls in advance for accurate spacing of surface bond patterns with uniform joint widths and for accurate locating of openings, movement-type joints, returns, and offsets. Avoid the use of less-than-half-size units at corners, jambs, and where possible at other locations.
- B. Lay solid masonry units in full bed of mortar, with full head joints, uniformly jointed with other work.
 - 1. Bed webs in mortar in starting course on footings and in all courses of piers, columns, and pilasters, and where adjacent to cells or cavities to be filled with grout.

2. For starting course on footings where cells are not grouted, spread out full mortar bed including areas under cells.
- C. Lay hollow masonry units with face shell bedding on head and bed joints.
- D. Buttering corners of joints or excessive furrowing of mortar joints is not permitted.
- E. Remove excess mortar and mortar smears as work progresses.
- F. Interlock intersections and external corners, except for units laid in stack bond.
- G. Do not shift or tap masonry units after mortar has achieved initial set. Where adjustment must be made, remove mortar and replace.
- H. Perform job site cutting of masonry units with proper tools (motor-driven saws) to provide straight, clean, unchipped edges. Prevent broken masonry unit corners or edges. Use full-size units without cutting where possible.

3.06 REINFORCEMENT AND ANCHORAGE - GENERAL AND SINGLE WYTHE MASONRY

- A. Place continuous joint reinforcement in first and second joint below top of walls.
- B. Embed longitudinal wires of joint reinforcement in mortar joint with at least 5/8 inch mortar cover on each side.
- C. Lap joint reinforcement ends as indicated on Drawings, minimum 6 inches.
- D. Reinforce joint corners and intersections with strap anchors 16 inches on center.
- E. Fasten anchors to structural framing and embed in masonry joints as masonry is laid. Unless otherwise indicated on drawings or closer spacing is indicated under specific wall type, space anchors at maximum of 16 inches horizontally and 16 inches vertically.

3.07 CONTROL AND EXPANSION JOINTS

- A. Control Joints: As indicated on Drawings.
- B. Control Joints: Locate control joints maximum 24 feet on center or as indicated. If not shown, provide submittal to Architect with proposed locations for approval.
- C. Expansion Joints: As indicated on Drawings.
- D. Do not continue horizontal joint reinforcement through control or expansion joints.
- E. Install preformed control joint device in continuous lengths. Seal butt and corner joints in accordance with manufacturer's instructions.
- F. Size control joints as indicated on drawings; if not indicated, 3/4 inch wide and deep.
- G. Comply with Section 07 92 00 for sealant performance.
- H. Form expansion joint as detailed on drawings.

3.08 TOLERANCES

- A. Install masonry within the site tolerances found in TMS 402/602.
- B. Verify tolerances prior to placing next course. If the unit placed does not meet the tolerances listed below, it shall be removed and reinstalled to meet specified tolerances at no additional cost to District.
- C. Maximum Variation from Alignment of Columns: 1/4 inch.
- D. Maximum Variation From Unit to Adjacent Unit: 1/16 inch.

- E. Maximum Variation from Plane of Wall: 1/4 inch in 10 ft and 1/2 inch in 20 ft or more.
- F. Maximum Variation from Plumb: 1/4 inch per story non-cumulative; 1/2 inch in two stories or more.
- G. Maximum Variation from Level Coursing: 1/8 inch in 3 ft and 1/4 inch in 10 ft; 1/2 inch in 30 ft.
- H. Maximum Variation of Mortar Joint Thickness: Head joint, minus 1/4 inch, plus 3/8 inch.
- I. Maximum Variation from Cross Sectional Thickness of Walls: 1/4 inch.

3.09 CUTTING AND FITTING

- A. Cut and fit for chases and sleeves. Coordinate with other sections of work to provide correct size, shape, and location.
- B. Obtain approval prior to cutting or fitting masonry work not indicated or where appearance or strength of masonry work may be impaired.

3.10 FIELD QUALITY CONTROL

- A. An independent testing agency will perform field quality control tests, as specified in Section 01 40 00 - Quality Requirements.
- B. Inspection and Core Tests shall be per CBC 1705A.4 and 2105A.4.

3.11 REPAIRING AND POINTING

- A. Repairing: Remove and replace masonry units that are loose, chipped, broken, stained, or otherwise damaged or if units do not match adjoining units. Install new units to match adjoining units and in fresh mortar or grout, pointed to eliminate evidence of replacement.
- B. Pointing: During the tooling of joints, enlarge any voids or holes, except weep holes, and completely fill with mortar. Point-up all joints including corners, openings, and adjacent construction to provide a neat, uniform appearance, prepared for application of sealants.

3.12 CLEANING

- A. Remove excess mortar and mortar droppings.
- B. Replace defective mortar. Match adjacent work.
- C. Clean soiled surfaces with cleaning solution.
- D. Use non-metallic tools in cleaning operations.
- E. Final Cleaning: After mortar is thoroughly set and cured, clean exposed masonry as follows:
 1. Remove large mortar particles by hand with wooden paddles and nonmetallic scrape hoes or chisels.
 2. Test cleaning methods on sample wall panel; leave 1/2 panel uncleaned for comparison purposes. Obtain Architect's approval of sample cleaning before proceeding with cleaning of masonry.
 3. Wet wall surfaces with water prior to application of cleaners; remove cleaners promptly by rinsing thoroughly with clear water.
 4. Clean concrete unit masonry by means of cleaning method indicated in NCMA TEK 45 applicable to type of stain present on exposed surfaces.

3.13 PROTECTION

- A. Without damaging completed work, provide protective boards at exposed external corners that are subject to damage by construction activities.

END OF SECTION

SECTION 05 50 00
METAL FABRICATIONS

PART 1 GENERAL

1.01 SECTION INCLUDES

- A. Shop fabricated steel items.

1.02 RELATED REQUIREMENTS

- A. Section 03 30 00 - Cast-in-Place Concrete: Placement of metal fabrications in concrete.
- B. Section 05 12 00 - Structural Steel Framing: Structural steel column anchor bolts.
- C. Section 09 91 13 - Exterior Painting: Paint finish.
- D. Section 09 91 23 - Interior Painting: Paint finish.

1.03 REFERENCE STANDARDS

- A. AISC 201 - AISC Certification Program for Structural Steel Fabricators, Standard for Steel Building Structures.
- B. ASTM A36/A36M - Standard Specification for Carbon Structural Steel.
- C. ASTM A53/A53M - Standard Specification for Pipe, Steel, Black and Hot-Dipped, Zinc-Coated, Welded and Seamless.
- D. ASTM A123/A123M - Standard Specification for Zinc (Hot-Dip Galvanized) Coatings on Iron and Steel Products.
- E. ASTM A307 - Standard Specification for Carbon Steel Bolts, Studs, and Threaded Rod 60 000 PSI Tensile Strength.
- F. ASTM A500/A500M - Standard Specification for Cold-Formed Welded and Seamless Carbon Steel Structural Tubing in Rounds and Shapes.
- G. AWS A2.4 - Standard Symbols for Welding, Brazing, and Nondestructive Examination.
- H. AWS B2.1/B2.1M - Specification for Welding Procedure and Performance Qualification.
- I. AWS D1.1/D1.1M - Structural Welding Code - Steel.
- J. AWS D1.2/D1.2M - Structural Welding Code - Aluminum.
- K. IAS AC172 - Accreditation Criteria for Fabricator Inspection Programs for Structural Steel.
- L. SSPC-PA 1 - Shop, Field, and Maintenance Painting of Steel.
- M. SSPC-Paint 15 - Steel Joist Shop Primer/Metal Building Primer.
- N. SSPC-Paint 20 - Zinc-Rich Primers (Type I, "Inorganic," and Type II, "Organic").

1.04 SUBMITTALS

- A. See Section 01 30 00 - Administrative Requirements, for submittal procedures.
- B. Shop Drawings: Indicate profiles, sizes, connection attachments, reinforcing, anchorage, size and type of fasteners, and accessories. Include erection drawings, elevations, and details where applicable.

1. Indicate welded connections using standard AWS A2.4 welding symbols. Indicate net weld lengths.
- C. Welders' Qualification Statement: Welders' certificates in accordance with AWS B2.1/B2.1M and dated no more than 12 months before start of scheduled welding work.
- D. Fabricator's Qualification Statement: Provide documentation showing steel fabricator is accredited under IAS AC172 or AISC 201.

1.05 QUALITY ASSURANCE

- A. Welder Qualifications: Welding processes and welding operators qualified in accordance with AWS D1.1/D1.1M and AWS D1.2/D1.2M and dated no more than 12 months before start of scheduled welding work.
- B. Fabricator Qualifications: A qualified steel fabricator that is accredited by IAS AC172 or AISC 201.

PART 2 PRODUCTS

2.01 REGULATORY REQUIREMENTS

- A. Conform to applicable requirements of California Building Code (CBC), Title 24, Part 2, as amended and adopted by authorities having jurisdiction.
 1. Comply with Title 24, Part 9, California Fire Code Chapter 35 "Welding and Other Hot Work."

2.02 MATERIALS - STEEL

- A. Steel Sections: ASTM A36/A36M, for channels, angles and plates.
- B. Steel Tubing: ASTM A500/A500M, Grade B cold-formed structural tubing.
- C. Pipe: ASTM A53/A53M, Grade B Schedule 40, black finish.
- D. Mechanical Fasteners: Same material as or compatible with materials being fastened; type consistent with design and specified quality level.
- E. Bolts, Nuts, and Washers: ASTM A307, Grade A, plain.
- F. Welding Materials: AWS D1.1/D1.1M; type required for materials being welded.
- G. Shop and Touch-Up Primer: SSPC-Paint 15, complying with VOC limitations of authorities having jurisdiction.
 1. Comply with SSPC-PA 1. Coordinate with requirements specified in Section 09 91 13 - Exterior Painting and 09 91 23 - Interior Painting .
 - a. Coordinate primer with finish paint and coating, as applicable, to provide sound foundation for field-applied topcoats despite prolonged exposure during construction.
- H. Galvanize all exterior steel members to comply with ASTM A123/A123M. Provide minimum 1.7 oz/sq ft galvanized coating.
- I. Touch-Up Primer for Galvanized Surfaces: SSPC-Paint 20, Type I - Inorganic, complying with VOC limitations of authorities having jurisdiction.

2.03 FABRICATION

- A. Ferrous Metal Surfaces, General:
 - 1. For metal fabrications exposed to view upon completion of the Work: Provide ferrous metals materials selected for their surface flatness, smoothness, and freedom from surface blemishes.
 - 2. Do not use materials whose exposed surfaces exhibit pitting, seam marks, roller marks, rolled trade names, roughness, and, for steel sheet, variations in flatness exceeding those permitted by reference standards for stretcher-leveled sheet.
- B. Hot-dip galvanize fabricated ferrous items, indicated as remaining unpainted, after fabrication. Field connections shall be bolted or screwed where possible. Avoid field cutting and welding which damage galvanized coating.
- C. Fit and shop assemble items in largest practical sections, for delivery to site.
- D. Fabricate items with joints tightly fitted and secured.
- E. Gas cutting of non-structural steel items may be acceptable where stress is not transmitted through flame-cut surfaces.
 - 1. Make cuts clean and to contour.
 - 2. Deduct 1/8 inch from effective width of members cut by torch.
- F. Continuously seal joined members by continuous welds.
- G. Joints Exposed to Weather or Water: Fabricate to keep water out, or provide adequate drainage of water that penetrates.
- H. Steel Tubing and Piping Fabrication: Unless otherwise indicated, close ends with plate stock so no exposed ends of tubing and piping. Grind all edges.
- I. Connections, General:
 - 1. Component parts of built-up members shall be well-pinned with closely-fitted contact.
 - 2. Conceal connections where possible.
 - 3. Otherwise, make countersinks for concealment after fabrication, except where noted.
- J. Welding: Conform to AWS D1.1/D1.1M recommendations.
 - 1. Do not field weld galvanized components to remain unfinished.
 - 2. Provide continuous welds at welded corners and seams.
 - 3. Grind exposed welds smooth and flush with base material.
 - 4. Re-weld to fill holes. Putties and fillers are not acceptable.
- K. Grind exposed joints flush and smooth with adjacent finish surface. Make exposed joints butt tight, flush, and hairline. Ease exposed edges to small uniform radius.
- L. Exposed Mechanical Fastenings: Flush countersunk screws or bolts; unobtrusively located; consistent with design of component, except where specifically noted otherwise.
 - 1. Bolted and Screwed Connections:
 - a. Provide holes and connections for work specified in other Sections.
 - b. Use bolts for field connections only.
 - c. Provide washers under heads and nuts bearing on wood.

- d. Draw all nuts tight and nick threads of permanent connections.
 - e. Use beveled washers where bearing is on sloped surfaces.
 - f. Where screws must be used for permanent connections in ferrous metal, use flat head type, countersunk, with screw slots filled and finished smooth and flush.
- M. Supply components required for anchorage of fabrications. Fabricate anchors and related components of same material and finish as fabrication, except where specifically noted otherwise.

2.04 FABRICATED ITEMS

- A. Rough Hardware
 - 1. Provide bent or otherwise custom fabricated bolts, plates, anchors, hangers, dowels, and other miscellaneous steel and iron shapes as indicated on Drawings.
- B. Other Products and Fabrications
 - 1. Other Products and Fabrications: Provide all materials not specifically described but required for a complete and proper installation, as selected by the Contractor, subject to review and acceptance by Construction Manager and Architect.

2.05 FINISHES - STEEL

- A. Mechanical Finishes: Complete finishing prior to fabrication wherever possible.
 - 1. After fabrication, finish all joints, bends, abrasions, and other surface blemishes to match finish.
 - 2. Protect finish on exposed surfaces by using temporary protective covering.
- B. Clean surfaces of rust, scale, grease, and foreign matter prior to finishing.
- C. Galvanizing of Structural Steel Members: Galvanize all exterior steel members after fabrication to ASTM A123/A123M requirements. Provide minimum 1.7 oz/sq ft galvanized coating.
- D. Galvanizing of Non-structural Items: Galvanize all exterior steel members after fabrication to ASTM A123/A123M requirements.

2.06 FABRICATION TOLERANCES

- A. Squareness: 1/8 inch maximum difference in diagonal measurements.
- B. Maximum Offset Between Faces: 1/16 inch.
- C. Maximum Misalignment of Adjacent Members: 1/16 inch.
- D. Maximum Bow: 1/8 inch in 48 inches.
- E. Maximum Deviation From Plane: 1/16 inch in 48 inches.
- F. Punch, drill and reaming in manner to leave clean, true lines and surfaces.
 - 1. Oversize hole 1/16 inch by punching, when material thickness is equal to or less than bolt diameter plus 1/8 inch.
 - 2. Sub-punch 1/16 inch smaller than bolt and drill or ream to oversize by 1/16 inch, when material thickness is thicker than bolt diameter plus 1/8 inch.

PART 3 EXECUTION

3.01 EXAMINATION

- A. Verify that field conditions are acceptable and are ready to receive work.
- B. Field Inspection of Fabricated Products: Prior to installation, inspect products for damage and verify markings and dimensions against reviewed submittals.
- C. Coordination: Coordinate metal fabrications Work with Work specified in other Sections so that related Work shall be accurately and properly joined.

3.02 PREPARATION

- A. Clean and strip primed steel items to bare metal where site welding is required.
- B. Supply setting templates to the appropriate entities for steel items required to be cast into concrete.
- C. Make provision for erection loads with temporary bracing. Keep work in alignment.
- D. Obtain Architect's review prior to site cutting or making adjustments not indicated on Drawings and reviewed shop drawings.

3.03 INSTALLATION

- A. Install items plumb and level, accurately fitted, free from distortion or defects.
- B. Provide for erection loads, and for sufficient temporary bracing to maintain true alignment until completion of erection and installation of permanent attachments.
- C. Field weld components as indicated on drawings.
- D. Perform field welding in accordance with AWS D1.1/D1.1M.
- E. Obtain approval prior to site cutting or making adjustments not scheduled.

3.04 TOLERANCES

- A. Maximum Variation From Plumb: 1/4 inch per story, non-cumulative.
- B. Maximum Offset From True Alignment: 1/4 inch.
- C. Maximum Out-of-Position: 1/4 inch.

END OF SECTION

SECTION 05 52 13
PIPE AND TUBE RAILINGS

PART 1 GENERAL

1.01 SECTION INCLUDES

- A. Wall mounted handrails.
- B. Free-standing railings at steps or ramps.

1.02 RELATED REQUIREMENTS

- A. Section 03 30 00 - Cast-in-Place Concrete: Placement of anchors in concrete.
- B. Section 05 50 00 - Metal Fabrications: Embedded items, welding and shop painting.
- C. Section 06 10 00 - Rough Carpentry: Placement of backing in stud wall construction.

1.03 REFERENCE STANDARDS

- A. ADA Standards - Americans with Disabilities Act (ADA) Standards for Accessible Design.
- B. ASTM A53/A53M - Standard Specification for Pipe, Steel, Black and Hot-Dipped, Zinc-Coated, Welded and Seamless.
- C. ASTM A123/A123M - Standard Specification for Zinc (Hot-Dip Galvanized) Coatings on Iron and Steel Products.
- D. ASTM A500/A500M - Standard Specification for Cold-Formed Welded and Seamless Carbon Steel Structural Tubing in Rounds and Shapes.
- E. ASTM A780/A780M - Standard Practice for Repair of Damaged and Uncoated Areas of Hot-Dip Galvanized Coatings.
- F. ASTM E935 - Standard Test Methods for Performance of Permanent Metal Railing Systems and Rails for Buildings.
- G. AWS A2.4 - Standard Symbols for Welding, Brazing, and Nondestructive Examination.
- H. AWS B2.1/B2.1M - Specification for Welding Procedure and Performance Qualification.
- I. AWS D1.1/D1.1M - Structural Welding Code - Steel.
- J. AWS D1.1/D1.1M - Structural Welding Code - Steel.
- K. NAAMM AMP 521 - Pipe Railing Systems Manual.
- L. SSPC-Paint 20 - Zinc-Rich Primers (Type I, "Inorganic," and Type II, "Organic").

1.04 SUBMITTALS

- A. See Section 01 30 00 - Administrative Requirements, for submittal procedures.
- B. Shop Drawings: Indicate profiles, sizes, connection attachments, anchorage, size and type of fasteners, and accessories.
 - 1. Indicate welded connections using standard AWS A2.4 welding symbols. Indicate net weld lengths.
 - 2. Prepare shop drawings for all railing systems, including attachment.

3. Conform to AISC Standards, except provisions for approval/responsibility for dimensions by Architect and structural engineer shall not apply.
 4. Include erection drawings, elevations, and details where applicable.
 5. Indicate welded connections using standard AWS welding symbols. Indicate net weld lengths.
- C. Welders' Qualification Statement: Welders' certificates in accordance with AWS B2.1/B2.1M and dated within the previous 12 months.
- D. Fabricator's Qualification Statement.

1.05 QUALITY ASSURANCE

- A. Welder Qualifications: Welding processes and welding operators qualified within previous 12 months.
- B. Fabricator Qualifications:
1. A company specializing in manufacturing products specified in this section, with not less than ten years of documented experience.
- C. Coordination: Provide templates and sleeves for incorporation of embedded items into the work specified elsewhere herein.

1.06 DELIVERY, STORAGE AND HANDLING

- A. Delivery, Storage and Handling, General: Protect products from deformation, marring, discoloration, soiling and corrosion.
- B. Storage: Store products in enclosed, well-ventilated spaces, not in contact with soil or vegetation and not subject to inclement weather.

PART 2 PRODUCTS

2.01 RAILINGS - GENERAL REQUIREMENTS

- A. Regulatory Requirements: Conform to California Building Code (CBC), Title 24, Part 2, Section 11B-505 and 11B-405.8 as amended and adopted by authorities having jurisdiction.
1. Top of gripping surfaces of handrails shall be 34 inches minimum and 38 inches maximum vertically above walking surfaces, stair nosings, and ramp surfaces. Handrails shall be at a consistent height above such surfaces.
 2. Clearance between handrail gripping surfaces and adjacent surfaces shall be 1-1/2 inches minimum.
 - a. Handrail may be located in a recess if the recess is 3 inches maximum deep and 18 inches minimum clear above the top of the handrail.
 3. Handrail gripping surfaces shall be continuous along their length and shall not be obstructed along their tops or sides. The bottoms of handrail gripping surfaces shall not be obstructed for more than 20% of their length.
 - a. Where provided, horizontal projections shall occur 1-1/2 inches minimum below the bottom of the handrail gripping surfaces.
 4. Handrail gripping surfaces with a circular cross section shall have an outside diameter of 1-1/4 inch minimum and 2 inches maximum.

5. Handrail gripping surfaces with a non-circular cross section shall have an outside dimension of 4 inches minimum and 6-1/4 inches maximum, and a cross-sectional dimension of 2-1/4 inches maximum.
 6. Handrail gripping surfaces and any surfaces adjacent to them shall be free of sharp or abrasive elements and shall have rounded edges.
 7. Handrails shall not rotate within their fittings.
 8. Handrail gripping surfaces shall extend beyond and in the same direction of stair flights and ramp runs in accordance with CBC Section 11B-505.10.
 - a. Such extensions are not required for continuous handrails at the inside turn of switchback or dogleg stairs and ramps.
 9. A 2 inch minimum high curb or a barrier shall be provided to prevent the passage of a 4 inch diameter sphere rolling off the sides of a ramp surface.
 - a. Such a curb or barrier shall be continuous and uninterrupted along the length of a ramp. CBC Section 11B-405.9.2
- B. Design, fabricate, and test railing assemblies in accordance with the most stringent requirements of applicable local code.
 - C. Distributed Loads: Design railing assembly, wall rails, and attachments to resist distributed force of 75 pounds per linear foot applied to the top of the assembly and in any direction, without damage or permanent set. Test in accordance with ASTM E 935.
 - D. Concentrated Loads: Design railing assembly, wall rails, and attachments to resist a concentrated force of 200 pounds applied at any point on the top of the assembly and in any direction, without damage or permanent set. Test in accordance with ASTM E 935.
 1. Infill Area and Intermediate Rails: Resist a minimum horizontal concentrated load of 200 LBF applied to one square foot at any point in the system, including panels, intermediate rails balusters, or other elements composing the infill area.
 - E. Allow for expansion and contraction of members and building movement without damage to connections or members.
 - F. Dimensions: See drawings for configurations and heights.
 1. Top Rails and Wall Rails: 1-1/2 inches outside diameter, round.
 2. Intermediate Rails: 1-1/2 inches diameter, round.
 - G. Provide anchors and other components as required to attach to structure, made of same materials as railing components unless otherwise indicated; where exposed fasteners are unavoidable provide flush countersunk fasteners.
 1. For anchorage to concrete, provide inserts to be cast into concrete, for welding anchors.
 2. For anchorage to stud walls, provide backing plates, for bolting anchors.
 - H. Provide welding fittings to join lengths, seal open ends, and conceal exposed mounting bolts and nuts, including but not limited to elbows, T-shapes, splice connectors, flanges, escutcheons, and wall brackets.

2.02 STEEL RAILING SYSTEM

- A. Steel Tube: ASTM A500/A500M, Grade B cold-formed welded or seamless structural tubing.

- B. Steel Pipe: ASTM A 53/A 53M, Grade B Schedule 40, black and galvanized finish, as indicated, seamless or welded.
- C. Welding Fittings: Factory- or shop-welded from matching pipe or tube; seams continuously welded; joints and seams ground smooth.
- D. Exposed Fasteners: No exposed bolts or screws.
- E. Straight Splice Connectors: Steel concealed spigots.
- F. Galvanizing: In accordance with requirements of ASTM A123/A123M.
 - 1. Touch-Up Primer for Galvanized Surfaces: SSPC-Paint 20, Type I - Inorganic.

2.03 FABRICATION

- A. Fabricate railings in accordance with NAAMM AMP 521 and as required for specified design requirements. Provide stock and tubing and manufactured components sized and arranged as indicated on Drawings and specified herein.
- B. Accurately form components to suit specific project conditions and for proper connection to building structure.
 - 1. Prior to fabrication, field verify dimensions and details of construction. Immediately report variances in writing to Architect.
- C. Fit and shop assemble components in largest practical sizes for delivery to site.
- D. Fabricate components with joints tightly fitted and secured. Provide spigots and sleeves to accommodate site assembly and installation.
- E. Welded Joints:
 - 1. Exterior Components (Type 2): Continuously seal joined pieces by continuous welds. Drill condensate drainage holes at bottom of members at locations that will not encourage water intrusion.
 - 2. Grind exposed joints flush and smooth with adjacent finish surface. Make exposed joints butt tight, flush, and hairline. Ease exposed edges to small uniform radius (1/8 inch).
- F. Weld connections that cannot be shop welded due to size limitations.
 - 1. Weld in accordance with AWS D1.1/D1.1M.
 - 2. Match shop welding and bolting.
 - 3. Clean welds, bolted connections, and abraded areas.
 - 4. Touch up shop primer and factory-applied finishes.
 - 5. Repair galvanizing with galvanizing repair paint per ASTM A780/A780M.

PART 3 EXECUTION

3.01 EXAMINATION

- A. Verify that field conditions are acceptable and are ready to receive work.
- B. Coordination: Coordinate fabrication and installation of steel pipe and tube railings so that related Work accurately and properly join.

3.02 PREPARATION

- A. Obtain Architect's review prior to site cutting or making adjustments not indicated on shop drawings.
- B. Supply items required to be cast into concrete with setting templates, for installation as work of other sections.

3.03 INSTALLATION

- A. Install in accordance with manufacturer's instructions.
- B. Install components plumb and level, accurately fitted, free from distortion or defects, with tight joints.
- C. Install railings in compliance with CBC 11B and ADA Standards for accessible design at applicable locations.
- D. Anchor railings securely to structure.
- E. Field weld anchors as indicated on drawings. Touch-up welds with primer. Grind welds smooth.
- F. Conceal anchor bolts and screws whenever possible. Where not concealed, use flush countersunk fastenings.
- G. Guardrails Installation: Install railings plumb and level, accurately fitted, free from distortion or defects.
 - 1. Plumb posts in each direction.
 - 2. Temporarily install sections and align before securing sections together.
 - 3. Fully weld all joints and grind smooth as for shop welding.
 - 4. Perform field welding in accordance with AWS D1.1/D1.1M.
- H. Wall Railings Installation, General: Secure handrails to wall with wall brackets and end return fittings.
 - 1. Provide brackets with 1-1/2 inch clearance from inside face of handrail and finished wall surface.
 - 2. Locate brackets as indicated, or if not indicated, at spacing required to support structural loads.
 - 3. Secure wall brackets to building construction as specified below.
 - a. Secure railing to bracket with pre-drilled hole for exposed bolt anchorage.
 - b. Securing Railings to Concrete Walls as Applicable: Anchor railings to concrete substrate with expansion anchors.
 - c. Railing intermediate supports: Secure to wall with specified handrail brackets.
 - d. Railing ends: None. Return railings to within 1/4 inch of wall face and provide handrail bracket within 12 inches of end of railing.
 - e. Securing Railings to Wood Stud Framed Walls as Applicable: Anchor brackets and fittings directly to minimum 4 x framing, or minimum 2 x solid blocking with wood screws or lag bolts as specified in Section 05 50 00 - Metal Fabrications and Section 06 10 00 - Rough Carpentry.

3.04 TOLERANCES

- A. Code required dimensions indicated on Drawings as minimum or maximum are absolute. No tolerances are allowed less or more than this dimension.
- B. Maximum Variation From Plumb: 1/4 inch per floor level, non-cumulative.
- C. Maximum Offset From True Alignment: 1/4 inch.
- D. Maximum Out-of-Position: 1/4 inch.

3.05 CLEANING AND PROTECTION

- A. Galvanizing Repair Compound:
 - 1. If finish is to be painted or is otherwise not visible, field repair with premixed cold galvanizing compound for field touch-up of galvanized coatings.
 - 2. Where the finish is galvanized, resend to galvanizing for reapplication, if practical (e.g.; bolted components) and accepted by Architect.
- B. Cleaning:
 - 1. Clean and dress all field welds, bolted connections, and abraded areas of galvanizing or shop paint on miscellaneous metal.

END OF SECTION

SECTION 06 10 00
ROUGH CARPENTRY

PART 1 GENERAL

1.01 SECTION INCLUDES

- A. Structural dimension lumber framing.
- B. Nonstructural dimension lumber framing.
- C. Preservative treated wood materials.
- D. Miscellaneous framing and sheathing.
- E. Communications and electrical room mounting boards.
- F. Concealed wood blocking, nailers, and supports.
- G. Miscellaneous wood nailers, furring, and grounds.

1.02 RELATED REQUIREMENTS

- A. Section 01 61 16 - Volatile Organic Compound (VOC) Content Restrictions.
- B. Section 03 30 00 - Cast-in-Place Concrete: Setting anchors in concrete.
- C. Section 05 50 00 - Metal Fabrications: Miscellaneous steel connectors and support angles for wood framing.

1.03 REFERENCE STANDARDS

- A. ASTM A153/A153M - Standard Specification for Zinc Coating (Hot-Dip) on Iron and Steel Hardware.
- B. ASTM A653/A653M - Standard Specification for Steel Sheet, Zinc-Coated (Galvanized) or Zinc-Iron Alloy-Coated (Galvannealed) by the Hot-Dip Process.
 - 1. Use 2015 as indicated in 2016 CBC Referenced Standards.
- C. ASTM C557 - Standard Specification for Adhesives for Fastening Gypsum Wallboard to Wood Framing.
- D. ASTM D3498 - Standard Specification for Adhesives for Field-Gluing Wood Structural Panels (Plywood or Oriented Strand Board) to Wood Based Floor System Framing.
- E. ASTM E84 - Standard Test Method for Surface Burning Characteristics of Building Materials.
- F. AWC NDS - National Design Specification® (NDS®) for Wood Construction.
- G. AWC SDPWS - Special Design Provisions for Wind and Seismic.
- H. AWPA U1 - Use Category System: User Specification for Treated Wood.
- I. PS 1 - Structural Plywood.
- J. PS 2 - Performance Standard for Wood-Based Structural-Use Panels.
- K. PS 20 - American Softwood Lumber Standard.
- L. WCLIB (GR) - Standard Grading Rules for West Coast Lumber No. 17.

1.04 SUBMITTALS

- A. See Section 01 30 00 - Administrative Requirements for submittal procedures.
- B. Product Data: Provide technical data on wood preservative materials and application instructions.
- C. Samples: For rough carpentry members that will be exposed to view, submit two samples, ___ by ___ inch in size illustrating wood grain, color, and general appearance.
- D. Evaluation Service Reports: Show compliance with specified requirements.
- E. Manufacturer's Certificate: Certify that wood products supplied for rough carpentry meet or exceed specified requirements.

1.05 DELIVERY, STORAGE, AND HANDLING

- A. General: Cover wood products to protect against moisture. Support stacked products to prevent deformation and to allow air circulation.

1.06 WARRANTY

- A. See Section 01 78 00 - Closeout Submittals for additional warranty requirements.
- B. Correct defective work within a two-year period commencing on Date of Substantial Completion.

PART 2 PRODUCTS

2.01 GENERAL REQUIREMENTS

- A. Dimension Lumber: Comply with PS 20 and requirements of specified grading agencies.
 - 1. If no species is specified, provide species graded by the agency specified; if no grading agency is specified, provide lumber graded by grading agency meeting the specified requirements.
 - 2. Grading Agency: Grading agency whose rules are approved by the Board of Review, American Lumber Standard Committee at www.alsc.org, and who provides grading service for the species and grade specified; provide lumber stamped with grade mark unless otherwise indicated.
 - 3. Lumber of other species or grades is acceptable provided structural and appearance characteristics are equivalent to or better than products specified.

2.02 DIMENSION LUMBER FOR CONCEALED APPLICATIONS

- A. Grading Agency: West Coast Lumber Inspection Bureau; WCLIB (GR).
- B. Sizes: Nominal sizes as indicated on drawings, S4S.
- C. Moisture Content: S-dry or MC19. Maximum 19%.
- D. Joist, Rafter, and Small Beam Framing (2 by 6 through 4 by 16):
 - 1. Species: Douglas Fir-Larch.
 - 2. Grade: No. 1 and Better.
 - a. No. 1 & Better for joists and rafters;

- b. No. 1 for beams and stringers.

2.03 EXPOSED DIMENSION LUMBER

- A. Grading Agency: West Coast Lumber Inspection Bureau; WCLIB (GR).
- B. Sizes: Nominal sizes as indicated on drawings.
- C. Surfacing: S4S.
- D. Moisture Content: S-dry or MC19.
- E. Stud Framing (2 by 2 through 2 by 6):
 - 1. Species: Douglas Fir.
 - 2. Grade: Clear.
- F. Joist, Rafter, and Small Beam Framing (2 by 6 through 4 by 16):
 - 1. Species: Douglas Fir.
 - 2. Grade: Select Heart.

2.04 CONSTRUCTION PANELS

- A. Wall Sheathing: Any PS 2 type plywood.
 - 1. Bond Classification: Exterior.
 - 2. Grade: Structural I Sheathing.
 - 3. Span Rating: 24.
 - 4. Performance Category: 15/32 PERF CAT.
 - 5. Edge Profile: Square edge.
- B. Communications and Electrical Room Mounting Boards: PS 1 A-D plywood, or medium density fiberboard; 3/4 inch thick; flame spread index of 25 or less, smoke developed index of 450 or less, when tested in accordance with ASTM E84.
- C. Other Applications:
 - 1. Plywood Concealed From View But Located Within Exterior Enclosure: PS 1, C-C Plugged or better, Exterior grade.
 - 2. Plywood Exposed to View But Not Exposed to Weather: PS 1, A-D, or better.
 - 3. Other Locations: PS 1, C-D Plugged or better.

2.05 ACCESSORIES

- A. Fasteners and Anchors:
 - 1. Metal and Finish: Hot-dipped galvanized steel complying with ASTM A153/A153M for high humidity and preservative-treated wood locations, unfinished steel elsewhere.
- B. Die-Stamped Connectors: Hot dipped galvanized steel, sized to suit framing conditions. Provide connectors manufactured by Simpson Strong-Tie.
 - 1. For contact with preservative treated wood in exposed locations, provide minimum G185 galvanizing complying with ASTM A653/A653M.
- C. Sill Flashing: As specified in Section 07 62 00.

- D. Subfloor Adhesives: Waterproof, air cure type, cartridge dispensed; adhesives designed for subfloor applications and complying with either ASTM C557 or ASTM D3498.

2.06 FACTORY WOOD TREATMENT

- A. Treated Lumber and Plywood: Comply with requirements of AWPA U1 - Use Category System for wood treatments determined by use categories, expected service conditions, and specific applications.
 - 1. Preservative-Treated Wood: Provide lumber and plywood marked or stamped by an ALSC-accredited testing agency, certifying level and type of treatment in accordance with AWPA standards.
- B. Preservative Treatment:
 - 1. Manufacturers:
 - a. Lonza Group: www.wolmanizedwood.com.
 - b. Koppers Performance Chemicals, Inc: www.koppersperformancechemicals.com.
 - c. Viance, LLC; Preserve ACQ: www.treatedwood.com/#sle.
 - d. Substitutions: See Section 01 60 00 - Product Requirements.
 - 2. Preservative Pressure Treatment of Lumber Above Grade: AWPA U1, Use Category UC3B, Commodity Specification A using waterborne preservative.
 - a. Kiln dry lumber after treatment to maximum moisture content of 19 percent.
 - b. Treat lumber in contact with roofing, flashing, or waterproofing.
 - c. Treat lumber in contact with concrete.
 - d. Treat lumber in other locations as indicated.
 - 3. Preservative Pressure Treatment of Plywood Above Grade: AWPA U1, Use Category UC2 and UC3B, Commodity Specification F using waterborne preservative.
 - a. Kiln dry plywood after treatment to maximum moisture content of 19 percent.
 - b. Treat plywood in contact with roofing, flashing, or waterproofing.
 - c. Treat plywood in other locations as indicated.

PART 3 EXECUTION

3.01 PREPARATION

- A. Coordinate installation of rough carpentry members specified in other sections.

3.02 INSTALLATION - GENERAL

- A. Select material sizes to minimize waste.
- B. Reuse scrap to the greatest extent possible; clearly separate scrap for use on site as accessory components, including: shims, bracing, and blocking.
- C. Where treated wood is used on interior, provide temporary ventilation during and immediately after installation sufficient to remove indoor air contaminants.

3.03 FRAMING INSTALLATION

- A. Set structural members level, plumb, and true to line. Discard pieces with defects that would lower required strength.

- B. Make provisions for temporary construction loads, and provide temporary bracing sufficient to maintain structure in true alignment and safe condition until completion of erection and installation of permanent bracing.
- C. Install structural members full length without splices unless otherwise specifically detailed.
- D. Comply with member sizes, spacing, and configurations indicated, and fastener size and spacing indicated, but not less than required by AWC NDS, AWC SDPWS, and applicable codes.
- E. Construct double joist headers at floor and ceiling openings and under wall stud partitions that are parallel to floor joists; use metal joist hangers unless otherwise detailed.
- F. Frame wall openings with two or more studs at each jamb; support headers on cripple studs.

3.04 BLOCKING, NAILERS, AND SUPPORTS

- A. Provide framing and blocking members as indicated or as required to support finishes, fixtures, specialty items, and trim.
- B. In framed assemblies that have concealed spaces, provide solid wood fireblocking as required by applicable local code, to close concealed draft openings between floors and between top story and roof/attic space; other material acceptable to code authorities may be used in lieu of solid wood blocking.
 1. Comply with CBC Section 718.2 Fireblocking.

3.05 INSTALLATION OF CONSTRUCTION PANELS

- A. Wall Sheathing: Secure with long dimension perpendicular to wall studs, with ends over firm bearing and staggered, using nails or screws.
 1. Use plywood or other acceptable structural panels at building corners, for not less than 96 inches, measured horizontally.
- B. Communications and Electrical Room Mounting Boards: Secure with screws to studs with edges over firm bearing; space fasteners at maximum 24 inches on center on all edges and into studs in field of board.
 1. At fire-rated walls, install board over wall board indicated as part of the fire-rated assembly.
 2. Where boards are indicated as full floor-to-ceiling height, install with long edge of board parallel to studs.
 3. Install adjacent boards without gaps.
 4. Size and Location: As indicated on drawings.

3.06 SITE APPLIED WOOD TREATMENT

- A. Apply preservative treatment compatible with factory applied treatment at site-sawn cuts, complying with manufacturer's instructions.
- B. Allow preservative to dry prior to erecting members.

3.07 TOLERANCES

- A. Framing Members: 1/4 inch from true position, maximum.
- B. Variation from Plane, Other than Floors: 1/4 inch in 10 feet maximum, and 1/4 inch in 30 feet maximum.

3.08 FIELD QUALITY CONTROL

- A. See Section 01 40 00 - Quality Requirements, for additional requirements.

3.09 CLEANING

- A. Waste Disposal: See Section 01 74 19 - Construction Waste Management and Disposal.
 - 1. Comply with applicable regulations.
 - 2. Do not burn scrap on project site.
 - 3. Do not burn scraps that have been pressure treated.
 - 4. Do not send materials treated with pentachlorophenol, CCA, or ACA to co-generation facilities or “waste-to-energy” facilities.
- B. Do not leave wood, shavings, sawdust, etc. on the ground or buried in fill.
- C. Prevent sawdust and wood shavings from entering the storm drainage system.

END OF SECTION

SECTION 07 13 00
SHEET WATERPROOFING

PART 1 GENERAL

1.01 SECTION INCLUDES

- A. Sheet Waterproofing:
 - 1. Self-adhered modified bituminous sheet membrane.

1.02 RELATED REQUIREMENTS

- A. Section 03 30 00 - Cast-in-Place Concrete: Concrete substrate.
- B. Section 04 20 00 - Unit Masonry: Masonry joints prepared to receive waterproofing and flashings.
- C. Section 07 92 00 - Joint Sealants: Sealing moving joints in waterproofed surfaces that are not required to be treated in this section.
- D. Section 31 22 00 - Grading: Requirements for backfill.

1.03 REFERENCE STANDARDS

- A. ASTM D412 - Standard Test Methods for Vulcanized Rubber and Thermoplastic Elastomers--Tension.
- B. ASTM D570 - Standard Test Method for Water Absorption of Plastics.
- C. ASTM D903 - Standard Test Method for Peel or Stripping Strength of Adhesive Bonds.
- D. ASTM D1876 - Standard Test Method for Peel Resistance of Adhesives (T-Peel Test).
- E. ASTM D1970/D1970M - Standard Specification for Self-Adhering Polymer Modified Bituminous Sheet Materials Used as Steep Roofing Underlayment for Ice Dam Protection.
- F. ASTM D5295/D5295M - Standard Guide for Preparation of Concrete Surfaces for Adhered (Bonded) Membrane Waterproofing Systems.
- G. ASTM D5385/D5385M - Standard Test Method for Hydrostatic Pressure Resistance of Waterproofing Membranes.
- H. ASTM D6506/D6506M - Standard Specification for Asphalt Based Protection Board for Below-Grade Waterproofing.
- I. ASTM E96/E96M - Standard Test Methods for Water Vapor Transmission of Materials.
- J. ASTM E154/E154M - Standard Test Methods for Water Vapor Retarders Used in Contact with Earth Under Concrete Slabs, on Walls, or as Ground Cover.
- K. NRCA (WM) - The NRCA Waterproofing Manual.

1.04 SUBMITTALS

- A. See Section 01 30 00 - Administrative Requirements, for submittal procedures.
- B. Product Data: Provide data for membrane, surface conditioner, flexible flashings, and joint and crack sealants.
- C. Shop Drawings: Indicate special joint or termination conditions and conditions of interface with other materials.

- D. Certificate: Certify that products meet or exceed specified requirements.
- E. Manufacturer's Installation Instructions: Indicate special procedures.
- F. Warranty: Submit manufacturer warranty and ensure forms have been completed in District's name and registered with manufacturer.

1.05 QUALITY ASSURANCE

- A. Membrane Manufacturer Qualifications: Company specializing in manufacturing products specified in this section, with not less than three years of documented experience.
- B. Installer Qualifications: Company specializing in performing work of the type specified and with at least three years of documented experience.

1.06 MOCK-UP

- A. See Section 01 40 00 - Quality Requirements for additional requirements.
- B. Construct mock-up consisting of 100 sq ft of vertical waterproofed panel; to represent finished work including internal and external corners.
- C. Locate where directed.
- D. Mock-up may remain as part of this Work.

1.07 FIELD CONDITIONS

- A. Maintain ambient temperatures above 40 degrees F for 48 hours before and during application and until liquid or mastic accessories have cured.

1.08 WARRANTY

- A. See Section 01 78 00 - Closeout Submittals, for additional warranty requirements.
- B. Extended Warranty: Provide written guarantee from waterproofing membrane manufacturer, and furnish joint written warranty to District from waterproofing applicator and Contractor, covering all membranes, and other elements essential to be watertight.
- C. Contractor shall correct defective Work within a five year period after Date of Substantial Completion; remove and replace materials concealing waterproofing at no extra cost to District.
- D. Provide five year manufacturer warranty for waterproofing failing to resist penetration of water, except where such failures are the result of structural failures of building. Hairline cracking of concrete due to temperature change or shrinkage is not considered a structural failure.

PART 2 PRODUCTS

2.01 WATERPROOFING APPLICATIONS

- A. Self-Adhered Modified Bituminous Sheet Membrane:
 - 1. Location: Retaining walls.
 - 2. Cover with drainage panel.

2.02 MEMBRANE MATERIALS

- A. Self-Adhered Modified Bituminous Sheet Membrane:
 - 1. Thickness: 60 mil, 0.060 inch, minimum.
 - 2. Sheet Width: 36 inches, minimum.
 - 3. Tensile Strength:
 - a. Membrane: 325 psi, minimum, measured in accordance with ASTM D412 Method A, using die C and at spindle-separation rate of 2 inches per minute.
 - 4. Elongation at Break: 300 percent, minimum, measured in accordance with ASTM D412.
 - 5. Water Vapor Permeance: 0.05 perm, maximum, measured in accordance with ASTM E96/E96M.
 - 6. Low Temperature Flexibility: Unaffected when tested in accordance with ASTM D1970/D1970M at minus 20 degrees F, 180 degree bend on 1 inch mandrel.
 - 7. Peel Strength: 7 lb per inch, minimum, when tested in accordance with ASTM D903.
 - 8. Lap Adhesion Strength: 5 pounds per inch, minimum, when tested according to ASTM D 1876 modified (low temp.).
 - 9. Puncture Resistance: 50 lb, minimum, measured in accordance with ASTM E154/E154M.
 - 10. Water Absorption: 0.1 percent increase in weight, maximum, measured in accordance with ASTM D570, 24 hour immersion.
 - 11. Hydrostatic Resistance: Resists the weight of 200 ft when tested in accordance with ASTM D5385/D5385M.
 - 12. Adhesives, Sealants, Tapes, and Accessories: As recommended by membrane manufacturer.
 - 13. Manufacturers:
 - a. Carlisle Coatings & Waterproofing Inc; MiraDRI 860/861: www.carlisleccw.com/#sle.
 - b. GCP Applied Technologies; Bituthene 3000: www.gcpat.com/sle.
 - c. Henry Company; Blueskin WP 200: www.henry.com/#sle.
 - d. W.R. Meadows, Inc; MEL-ROL: www.wrmeadows.com/#sle.
 - e. Substitutions: See Section 01 60 00 - Product Requirements.

2.03 ACCESSORIES

- A. Attachment Materials:
 - 1. Circular Membrane Discs: 1-1/2 inch diameter with neoprene pads or as recommended by manufacturer.
- B. Seaming Materials: As recommended by membrane manufacturer.
- C. Membrane Sealant: As recommended by membrane manufacturer..
- D. Sealant for Cracks and Joints In Substrates: Resilient elastomeric joint sealant compatible with substrates and waterproofing materials.
- E. Protection Board: Provide type capable of preventing damage to waterproofing due to backfilling and construction traffic.

1. Multi-layer internally-reinforced asphaltic panels, 1/8 inch thick, nominal, complying with ASTM D6506/D6506M.
 2. Manufacturers:
 - a. W.R. Meadows, Inc; Protection Course: www.wrmeadows.com/#sle.
 - b. Substitutions: See Section 01 60 00 - Product Requirements.
- F. Drainage Panel: Drainage layer with geotextile filter fabric on earth side. See also Section 33 41 00 - Subdrainage.
1. Composition: Dimpled polystyrene, polyethylene, or polypropylene core; polypropylene filter fabric.
 - a. Manufacturers:
 - 1) American Wick Drain Corp.; Product Amerdrain 520: www.americanwick.com.
 - 2) Carlisle Coatings & Waterproofing; Product MiraDRAIN 6000: www.carlisle-ccw.com.
 - 3) CETCO; Product AquaDrain with Aquadrain 100BD Base Drain: www.cetco.com.
 - 4) JDR Enterprises, Inc.; Product J-DRain 420: www.j-drain.com.
 - 5) W.R. Meadows, Inc; Mel-Drain 5012: www.wrmeadows.com/#sle.
 - 6) Substitutions: See Section 01 60 00 - Product Requirements.
- G. Cant Strips: Premolded composition material.
- H. Flexible Flashings: Type recommended by membrane manufacturer.
- I. Termination Bars: Stainless steel; compatible with membrane and adhesives.
- J. Adhesives: As recommended by membrane manufacturer.
- K. Thinner and Cleaner: As recommended by adhesive manufacturer, compatible with sheet membrane.

PART 3 EXECUTION

3.01 EXAMINATION

- A. Verify existing conditions are acceptable prior to starting this work.
- B. Verify substrate surfaces are durable; free of matter detrimental to adhesion or application of waterproofing system.
- C. Verify items that penetrate surfaces to receive waterproofing are securely installed.

3.02 PREPARATION

- A. Protect adjacent surfaces from damage not designated to receive waterproofing.
- B. Clean and prepare surfaces to receive waterproofing in accordance with manufacturer's instructions; vacuum substrate clean.
- C. Do not apply waterproofing to surfaces unacceptable to membrane manufacturer.
- D. Fill non-moving joints and cracks with a filler compatible with waterproofing materials.
- E. Seal moving cracks with sealant and non-rigid filler, using procedures recommended by sealant and waterproofing manufacturers.

- F. Seal cracks and joints with sealant using depth to width ratio as recommended by sealant manufacturer.
- G. Surfaces for Adhesive Bonding: Apply surface conditioner at a rate recommended by manufacturer, and protect conditioner from rain or frost until dry.
- H. Concrete Surfaces for Adhesive Bonding: Prepare concrete substrate according to ASTM D5295/D5295M.
 - 1. Remove substances that inhibit adhesion including form release agents, curing compounds admixtures, laitance, moisture, dust, dirt, grease and oil.
 - 2. Repair surface defects including honeycombs, fins, tie holes, bug holes, sharp offsets, rutted cracks, ragged corners, deviations in surface plane, spalling and delaminations, as described in the reference standard.
 - 3. Remove and replace areas of defective concrete as specified in Section 03 30 00.
 - 4. Prepare concrete for adhesive bonded waterproofing using mechanical or chemical methods described in the referenced standard.
 - 5. Test concrete surfaces as described in the referenced standards. Verify surfaces are ready to receive adhesive bonded waterproofing membrane system.

3.03 INSTALLATION - MEMBRANE

- A. Install membrane waterproofing in accordance with manufacturer's instructions and NRCA (WM) applicable requirements.
- B. Roll out membrane, and minimize wrinkles and bubbles.
- C. Self-Adhering Membrane: Remove release paper layer, and roll out onto substrate with a mechanical roller to provide full contact bond.
- D. Overlap edges and ends, minimum 3 inches, seal permanently waterproof by method recommended by manufacturer, and apply uniform bead of sealant to joint edge.
- E. Reinforce membrane with multiple thickness of membrane material over joints, whether joints are static or dynamic.
- F. Weather lap joints on sloped substrate in direction of drainage, and seal joints and seams.
- G. Flexible Flashings: Seal items watertight that penetrate through waterproofing membrane with flexible flashings.
- H. Extend membrane over cants and up intersecting surfaces at membrane perimeter minimum 6 inches above horizontal surface for first ply and 4 inches at subsequent plies laid in shingle fashion.
- I. Seal membrane and flashings to adjoining surfaces.
 - 1. Install termination bar along edges.
 - 2. Install counterflashing over exposed edges.

3.04 INSTALLATION - DRAINAGE PANEL AND PROTECTION BOARD

- A. Place drainage panel directly against membrane, butt joints, place to encourage drainage downward. Scribe and cut boards around projections, penetrations, and interruptions.
- B. Place protection board directly against drainage panel; butt joints. Scribe and cut boards around projections, penetrations, and interruptions.

- C. Adhere protection board to substrate with compatible adhesive.

3.05 FIELD QUALITY CONTROL

- A. District will provide testing services in accordance with Section 01 45 33. Contractor shall provide temporary construction and materials for testing.
- B. Upon completion of horizontal membrane installation, dam installation area in preparation for flood testing.
- C. Flood to minimum depth of 1 inch with clean water, and after 48 hours inspect for leaks.
- D. If leaking is found, remove water, repair leaking areas with new waterproofing materials as directed by Architect; repeat flood test, and repair damage to building.
- E. When area is proven watertight, drain water and remove dam.

3.06 PROTECTION

- A. Do not permit traffic over unprotected or uncovered membrane.

END OF SECTION

SECTION 07 92 00
JOINT SEALANTS

PART 1 GENERAL

1.01 SECTION INCLUDES

- A. Nonsag gunnable joint sealants.
- B. Self-leveling pourable joint sealants.
- C. Joint backings and accessories.
- D. District-provided field quality control.

1.02 RELATED REQUIREMENTS

- A. Section 01 61 16 - Volatile Organic Compound (VOC) Content Restrictions: Additional requirements for sealants and primers.

1.03 REFERENCE STANDARDS

- A. ASTM C661 - Standard Test Method for Indentation Hardness of Elastomeric-Type Sealants by Means of a Durometer.
- B. ASTM C920 - Standard Specification for Elastomeric Joint Sealants.
- C. ASTM C1193 - Standard Guide for Use of Joint Sealants.
- D. ASTM C1330 - Standard Specification for Cylindrical Sealant Backing for Use with Cold Liquid-Applied Sealants.
- E. ASTM C1521 - Standard Practice for Evaluating Adhesion of Installed Weatherproofing Sealant Joints.
- F. SWRI (VAL) - SWR Institute Validated Products Directory.

1.04 SUBMITTALS

- A. See Section 01 30 00 - Administrative Requirements, for submittal procedures.
- B. Product Data for Sealants: Submit manufacturer's technical data sheets for each product to be used, that includes the following.
 - 1. Physical characteristics, including movement capability, VOC content, hardness, cure time, and color availability.
 - 2. List of backing materials approved for use with the specific product.
 - 3. Substrates that product is known to satisfactorily adhere to and with which it is compatible.
 - 4. Substrates the product should not be used on.
 - 5. Substrates for which use of primer is required.
 - 6. Installation instructions, including precautions, limitations, and recommended backing materials and tools.
 - 7. Sample product warranty.

8. Certification by manufacturer indicating that product complies with specification requirements.
9. SWRI Validation: Provide currently available sealant product validations as listed by SWRI (VAL) for specified sealants.
- C. Product Data for Accessory Products: Submit manufacturer's technical data sheet for each product to be used, including physical characteristics, installation instructions, and recommended tools.
- D. Color Cards for Selection: Where sealant color is not specified, submit manufacturer's color cards showing standard colors available for selection.
- E. Samples for Verification: Where custom sealant color is specified, obtain directions from Architect and submit at least two physical samples for verification of color of each required sealant.
- F. Installer's Qualification Statement.

1.05 QUALITY ASSURANCE

- A. Maintain one copy of each referenced document covering installation requirements on site.
- B. Manufacturer Qualifications: Company specializing in manufacturing the products specified in this section with minimum three years documented experience.
- C. Installer Qualifications: Company specializing in performing the work of this section and with at least three years of documented experience.
- D. District will employ an independent testing agency to perform the field quality control inspection and testing as referenced in PART 3 of this section and as follows, to prepare and submit the field quality control plan and log, and to provide recommendations of remedies in the case of failure.
 1. Contractor shall cooperate with testing agency and repair failures discovered and destructive test location damage.
- E. Field Adhesion Tests of Joints: Test for adhesion using most appropriate method in accordance with ASTM C1521, or other applicable method as recommended by manufacturer.

1.06 WARRANTY

- A. See Section 01 78 00 - Closeout Submittals, for additional warranty requirements.
- B. Correct defective work within a five year period after Date of Substantial Completion.
- C. Warranty: Include coverage for installed sealants and accessories that fail to achieve watertight seal , exhibit loss of adhesion or cohesion, or do not cure.

PART 2 PRODUCTS

2.01 MANUFACTURERS

- A. Non-Sag Sealants: Permits application in joints on vertical surfaces without sagging or slumping.
 1. Adhesives Technology Corporation: www.atcepoxy.com.
 2. Bostik Inc: www.bostik-us.com.

3. Dow Corning Corporation: www.dowcorning.com/construction/sle.
 4. Fortifiber Building Systems Group: www.fortifiber.com/sle.
 5. Hilti, Inc: www.us.hilti.com/#sle.
 6. Master Builders Solutions by BASF: www.master-builders-solutions.basf.us/en-us/#sle.
 7. Momentive Performance Materials, Inc (formerly GE Silicones): www.momentive.com/sle.
 8. Pecora Corporation: www.pecora.com.
 9. QUIKRETE Companies: www.quikrete.com/#sle.
 10. Sherwin-Williams Company: www.sherwin-williams.com.
 11. Sika Corporation: www.usa-sika.com.
 12. Specified Technologies Inc: www.stifirestop.com/#sle.
 13. Tremco Commercial Sealants & Waterproofing: www.tremcosealants.com/#sle.
 14. W.R. Meadows, Inc: www.wrmeadows.com/sle.
 15. Substitutions: See Section 01 60 00 - Product Requirements.
- B. Self-Leveling Sealants: Pourable or self-leveling sealant that has sufficient flow to form a smooth, level surface when applied in a horizontal joint.
1. Adhesives Technology Corporation: www.atcepoxy.com.
 2. Bostik Inc: www.bostik-us.com.
 3. Dayton Superior Corporation: www.daytonsuperior.com.
 4. Dow Corning Corporation: www.dowcorning.com/construction/sle.
 5. Master Builders Solutions by BASF: www.master-builders-solutions.basf.us/en-us/#sle.
 6. Pecora Corporation: www.pecora.com.
 7. QUIKRETE Companies: www.quikrete.com/#sle.
 8. Sherwin-Williams Company: www.sherwin-williams.com.
 9. Sika Corporation: www.usa-sika.com.
 10. Tremco Commercial Sealants & Waterproofing: www.tremcosealants.com/#sle.
 11. W.R. Meadows, Inc: www.wrmeadows.com/sle.
 12. Substitutions: See Section 01 60 00 - Product Requirements.

2.02 JOINT SEALANT APPLICATIONS

- A. Scope:
1. Exterior Joints: Seal open joints, whether or not the joint is indicated on drawings, unless specifically indicated not to be sealed. Exterior joints to be sealed include, but are not limited to, the following items.
 - a. Wall expansion and control joints.
 - 1) Unit Masonry.
 - 2) Cement Plastering System.
 - 3) Metal and Composite Panels.
 - 4) Siding.

- b. Construction joints in cast-in-place concrete
 - c. Joints between door, window, and other frames and adjacent construction.
 - d. Joints between different exposed materials.
 - e. Openings below ledge angles in masonry.
 - f. Control and expansion joints in ceilings and other overhead surfaces.
 - g. Other joints indicated below.
2. Do not seal the following types of joints.
- a. Intentional weepholes in masonry.
 - b. Joints indicated to be treated with manufactured expansion joint cover or some other type of sealing device.
 - c. Joints where sealant is specified to be provided by manufacturer of product to be sealed.
 - d. Joints where installation of sealant is specified in another section.
 - e. Joints between suspended panel ceilings/grid and walls.
- B. Type CP-1 - Control and Expansion Joints in Concrete Paving: Self-leveling polyurethane "traffic-grade" sealant.

2.03 JOINT SEALANTS - GENERAL

- A. Sealants and Primers: Provide products with levels of volatile organic compound (VOC) content as indicated in Section 01 61 16.
- B. Colors: As indicated on the drawings. Match adjacent surface.

2.04 NONSAG JOINT SEALANTS

- A. Type ST-1 - Silyl-Terminated Polyether (STPE) and Polyurethane (STPU) Sealant: ASTM C920, Grade NS, Uses M and A; single component; not expected to withstand continuous water immersion or traffic.
 - 1. Movement Capability: Plus and minus 35 percent, minimum.
 - 2. Hardness Range: 20 to 40, Shore A, when tested in accordance with ASTM C661.
 - 3. Color: To be selected by Architect from manufacturer's full range.
 - 4. Service Temperature Range: Minus 40 to 180 degrees F.
 - 5. Manufacturers:
 - a. Sherwin-Williams Company; Stampede 100 Low-Modulus Hybrid Urethane Sealant: www.sherwin-williams.com/#sle.
 - b. Substitutions: See Section 01 60 00 - Product Requirements.
- B. Type PS-1 - Polyurethane Sealant: ASTM C920, Grade NS, Uses M and A; single or multi-component; not expected to withstand continuous water immersion or traffic.
 - 1. Hardness Range: 20 to 35, Shore A, when tested in accordance with ASTM C661.
 - 2. Color: To be selected by Architect from manufacturer's full range.
 - 3. Service Temperature Range: Minus 40 to 180 degrees F.
 - 4. Manufacturers:

- a. Master Builders Solutions by BASF; MasterSeal NP1: www.master-builders-solutions.basf.us/en-us/#sle.
 - b. Sherwin-Williams Company; Stampede-1/-TX Polyurethane Sealant: www.sherwin-williams.com/#sle.
 - c. Sika Corporation; Sikaflex-1a: www.usa-sika.com/#sle.
 - d. Sika Corporation; Sikaflex-15 LM: www.usa-sika.com/#sle.
 - e. W. R. Meadows, Inc; POURTHANE NS: www.wrmeadows.com/#sle.
 - f. Substitutions: See Section 01 60 00 - Product Requirements.
- C. Non-Sag "Traffic-Grade" Polyurethane Sealant: ASTM C920, Grade NS, Uses M and A; single or multi-component; explicitly approved by manufacturer for continuous water immersion and traffic without the necessity to recess sealant below traffic surface.
- 1. Movement Capability: Plus and minus 25 percent, minimum.
 - 2. Hardness Range: 40 to 50, Shore A, when tested in accordance with ASTM C661.
 - 3. Color: To be selected by Architect from manufacturer's full range.
 - 4. Service Temperature Range: Minus 40 to 180 degrees F.

2.05 SELF-LEVELING SEALANTS

- A. Self-Leveling Silicone Sealant: ASTM C920, Grade P, Uses M and A; single or multicomponent, explicitly approved by manufacturer for traffic exposure when recessed below traffic surface; not expected to withstand continuous water immersion.
- 1. Movement Capability: Plus 100 percent, minus 50 percent, minimum.
 - 2. Hardness Range: 0 to 15, Shore A, when tested in accordance with ASTM C661.
 - 3. Color: To be selected by Architect from manufacturer's full range.
 - 4. Service Temperature Range: Minus 40 to 180 degrees F.
 - 5. Manufacturers:
 - a. Sika Corporation; Sikasil 728SL: www.usa-sika.com/#sle.
 - b. Substitutions: See Section 01 60 00 - Product Requirements.
- B. Type P-1 - Self-Leveling Polyurethane Sealant: ASTM C920, Grade P, Uses M and A; single or multi-component; explicitly approved by manufacturer for traffic exposure; not expected to withstand continuous water immersion .
- 1. Movement Capability: Plus and minus 25 percent, minimum.
 - 2. Hardness Range: 35 to 55, Shore A, when tested in accordance with ASTM C661.
 - 3. Color: To be selected by Architect from manufacturer's full range.
 - 4. Service Temperature Range: Minus 40 to 180 degrees F.
 - 5. Manufacturers:
 - a. Pecora Corporation: www.pecora.com.
 - b. Sherwin-Williams Company; Stampede 1SL Polyurethane Sealant: www.sherwin-williams.com/#sle.
 - c. Sika Corporation; Sikaflex-1c SL: www.usa-sika.com/#sle.
 - d. Substitutions: See Section 01 60 00 - Product Requirements.

- C. Self-Leveling Polysulfide Sealant: ASTM C920, Grade P, Uses M and A; multicomponent; explicitly approved by manufacturer for traffic exposure and continuous water immersion.
 - 1. Movement Capability: Plus and minus 25 percent.
 - 2. Hardness Range: 30 to 55, Shore A, when tested in accordance with ASTM C661.
 - 3. Color: To be selected by Architect from manufacturer's full range.
 - 4. Service Temperature Range: Minus 40 to 180 degrees F.
 - 5. Manufacturers:
 - a. W.R. Meadows, Inc; Deck-O-Seal (pourable): www.wrmeadows.com/#sle.
 - b. Substitutions: See Section 01 60 00 - Product Requirements.
- D. Rigid Self-Leveling Polyurethane Joint Filler: Two part, low viscosity, fast setting; intended for cracks and control joints not subject to significant movement.
 - 1. Hardness Range: Greater than 100, Shore A, and 50 to 80, Shore D, when tested in accordance with ASTM C661.
 - 2. Manufacturers:
 - a. ARDEX Engineered Cements; ARDEX ARDIFIX: www.ardexamericas.com/#sle.
 - b. Substitutions: See Section 01 60 00 - Product Requirements.

2.06 ACCESSORIES

- A. Backer Rod: Cylindrical cellular foam rod with surface that sealant will not adhere to, compatible with specific sealant used, and recommended by backing and sealant manufacturers for specific application.
 - 1. Type for Joints Not Subject to Pedestrian or Vehicular Traffic: ASTM C1330; Type C - Closed Cell Polyethylene.
 - 2. Type for Joints Subject to Pedestrian or Vehicular Traffic: ASTM C1330; Type B - Bi-Cellular Polyethylene.
 - 3. Closed Cell and Bi-Cellular: 25 to 33 percent larger in diameter than joint width.
- B. Backing Tape: Self-adhesive polyethylene tape with surface that sealant will not adhere to and recommended by tape and sealant manufacturers for specific application.
- C. Masking Tape: Self-adhesive, nonabsorbent, non-staining, removable without adhesive residue, and compatible with surfaces adjacent to joints and sealants.
- D. Joint Cleaner: Non-corrosive and non-staining type, type recommended by sealant manufacturer; compatible with joint forming materials.
- E. Primers: Type recommended by sealant manufacturer to suit application; non-staining.

PART 3 EXECUTION

3.01 EXAMINATION

- A. Verify that joints are ready to receive work.
- B. Verify that backing materials are compatible with sealants.
- C. Verify that backer rods are of the correct size.

- D. Preinstallation Adhesion Testing: Install a sample for each test location indicated in the test plan.
 - 1. Test each sample as specified in PART 1 under QUALITY ASSURANCE article.
 - 2. Notify Architect of date and time that tests will be performed, at least seven days in advance.
 - 3. Record each test on Preinstallation Adhesion Test Log as indicated.
 - 4. If any sample fails, review products and installation procedures, consult manufacturer, or take whatever other measures are necessary to ensure adhesion; re-test in a different location; if unable to obtain satisfactory adhesion, report to Architect.
 - 5. After completion of tests, remove remaining sample material and prepare joint for new sealant installation.

3.02 PREPARATION

- A. Remove loose materials and foreign matter that could impair adhesion of sealant.
- B. Clean joints, and prime as necessary, in accordance with manufacturer's instructions.
- C. Perform preparation in accordance with manufacturer's instructions and ASTM C1193.
- D. Mask elements and surfaces adjacent to joints from damage and disfigurement due to sealant work; be aware that sealant drips and smears may not be completely removable.

3.03 INSTALLATION

- A. Perform work in accordance with sealant manufacturer's requirements for preparation of surfaces and material installation instructions.
- B. Perform installation in accordance with ASTM C1193.
- C. Measure joint dimensions and size joint backers to achieve the following, unless otherwise indicated:
 - 1. Width/depth ratio of 2:1.
 - 2. Neck dimension no greater than 1/3 of the joint width.
 - 3. Surface bond area on each side not less than 75 percent of joint width.
- D. Install bond breaker backing tape where backer rod cannot be used.
- E. Install sealant free of air pockets, foreign embedded matter, ridges, and sags, and without getting sealant on adjacent surfaces.
- F. Do not install sealant when ambient temperature is outside manufacturer's recommended temperature range, or will be outside that range during the entire curing period, unless manufacturer's approval is obtained and instructions are followed.
- G. Nonsag Sealants: Tool surface concave, unless otherwise indicated; remove masking tape immediately after tooling sealant surface.

3.04 FIELD QUALITY CONTROL

- A. District will employ an independent testing agency to perform field quality control inspection and testing as specified in PART 1 under QUALITY ASSURANCE article.

- B. Non-Destructive Adhesion Testing: If there are any failures in first 100 linear feet, notify Architect immediately.
- C. Destructive Adhesion Testing: If there are any failures in first 1000 linear feet, notify Architect immediately.
- D. Remove and replace failed portions of sealants using same materials and procedures as indicated for original installation.
- E. Repair destructive test location damage immediately after evaluation and recording of results.

END OF SECTION

SECTION 10 14 00
SIGNAGE

PART 1 GENERAL

1.01 SECTION INCLUDES

- A. Room and door signs.

1.02 REFERENCE STANDARDS

- A. ADA Standards - Americans with Disabilities Act (ADA) Standards for Accessible Design.
- B. ASTM D1187/D1187M - Standard Specification for Asphalt-Base Emulsions for Use as Protective Coatings for Metal.

1.03 SUBMITTALS

- A. See Section 01 30 00 - Administrative Requirements, for submittal procedures.
- B. Product Data: Manufacturer's printed product literature for each type of sign, indicating sign styles, font, foreground and background colors, locations, overall dimensions of each sign.
- C. Signage Schedule: Provide information sufficient to completely define each sign for fabrication, including room number, room name, other text to be applied, sign and letter sizes, fonts, and colors.
 - 1. When room numbers to appear on signs differ from those on drawings, include the drawing room number on schedule.
 - 2. When content of signs is indicated to be determined later, request such information from District through Architect at least 2 months prior to start of fabrication; upon request, submit preliminary schedule.
 - 3. Submit for approval by District through Architect prior to fabrication.
- D. Samples: Submit two samples of each type of sign, of size similar to that required for project, illustrating sign style, font, and method of attachment.
- E. Selection Samples: Where colors are not specified, submit two sets of color selection charts or chips.
- F. Verification Samples: Submit samples showing colors specified.
- G. Manufacturer's Installation Instructions: Include installation templates and attachment devices.
- H. Manufacturer's Qualification Statement.
- I. Maintenance Materials: Furnish the following for District's use in maintenance of project.
 - 1. See Section 01 60 00 - Product Requirements, for additional provisions.

1.04 QUALITY ASSURANCE

- A. Manufacturer Qualifications: Company specializing in manufacturing the products specified in this section with minimum three years of documented experience.

1.05 DELIVERY, STORAGE, AND HANDLING

- A. Package signs as required to prevent damage before installation.
- B. Package room and door signs in sequential order of installation, labeled by floor or building.
- C. Store tape adhesive at normal room temperature.

1.06 FIELD CONDITIONS

- A. Do not install tape adhesive when ambient temperature is lower than recommended by manufacturer.
- B. Maintain this minimum temperature during and after installation of signs.

PART 2 PRODUCTS

2.01 MANUFACTURERS

- A. Flat Signs:
 - 1. ASI Sign Systems, Inc.: www.asisignage.com.
 - 2. Best Sign Systems, Inc: www.bestsigns.com.
 - 3. Cosco Industries (ADA signs): www.coscoarchitecturalsigns.com/#sle.
 - 4. Cosco Industries (non-ADA signs): www.coscoarchitecturalsigns.com/#sle.
 - 5. FASTSIGNS: www.fastsigns.com/#sle.
 - 6. Inpro: www.inprocorp.com/#sle.
 - 7. Mohawk Sign Systems, Inc: www.mohawksign.com.
 - 8. Seton Identification Products: www.seton.com/aec.
 - 9. Substitutions: See Section 01 60 00 - Product Requirements.

2.02 SIGNAGE APPLICATIONS

- A. Accessibility Compliance: Signs are required to comply with ADA Standards and applicable building codes, unless otherwise indicated; in the event of conflicting requirements, comply with the most comprehensive and specific requirements.
 - 1. Requirements for Persons with Disabilities: Provide identifying devices meeting the requirements for the physically disabled of the following codes:
 - a. California Building Code (CBC) Title 24, Part 2; Chapter 11B, Accessibility.
 - b. Code of Federal Regulations 36 CFR 1191 - Americans with Disabilities Act (ADA) Accessibility Guidelines for Buildings and Facilities.
 - c. Accessible Means of Egress Signage: CBC 1009.
 - 1) Two-Way Communications Signage: CBC 1009.8
 - (a) Provide at the landing of each elevator or bank of elevators on each accessible floor, one or more stories above or below the level of exit discharge. Coordinate content with system provider. CBC 1009.11
 - 2) When included, provide Area of Refuge Signage indicating special accessibility provisions as shown: CBC 1009.9

- (a) Each door providing access to an area of refuge from an adjacent floor area shall be identified by a sign stating: AREA OF REFUGE.
 - (b) Each door providing access to an exterior area for assisted rescue shall be identified by a sign stating: EXTERIOR AREA FOR ASSISTED RESCUE.
 - (c) Comply with Chapter 11B, Section 11B-703.5, as applicable, requirements for visual characters and include the International Symbol of Accessibility.
 - (d) Where exit sign illumination is required by Section 1013.3, the **signs shall be illuminated**.
 - (e) Locate at each door to an area of refuge and exterior area for assisted rescue in accordance with Section 1013.4, signage with visual characters, raised character and braille complying with Chapter 11B, Sections 11B-703.1, 11B-703.2, 11B-703.3 and 11B-703.5.
 - (f) Provide International Symbol of Accessibility to comply with Chapter 11B, Section 11B-703.
- 3) Directional Signage: CBC 1009.10.
- (a) Provide directional signage complying with Chapter 11B, Section 11B-703.5 indicating the location of all other means of egress and which are accessible means of egress:
 - (1) At exits serving a required accessible space but not providing an approved accessible means of egress.
 - (2) At elevator landings.
 - (3) Within areas of refuge.
2. Raised characters shall comply with CBC 11B-703.2.
- a. Depth: It shall be 1/32 inch minimum above their background and shall be sans serif uppercase and be duplicated in Braille.
 - b. Height: It shall be 5/8 inch minimum and 2 inches maximum based on the height of the uppercase letter "I". CBC Section 11B-703.2.5
 - c. Finish and contrast: Characters and their background shall have a non-glare finish. Character shall contrast with their background with either light characters on a dark background or dark characters on a light background. CBC Section 11B-703.5.1
 - d. Proportions: It shall be selected from fonts where the width of the uppercase letter "O" is 60 % minimum and 110 % maximum of the height of the uppercase letter "I". Stroke thickness of the uppercase letter "I" shall be 15% maximum of the height of the character. CBC Sections 11B-703.2.4 and 11B-703.2.6; If characters are both visual and raised, provide stroke width min. 10% and max. 15% of the character "I".
 - e. Character Spacing: Spacing between individual tactile characters shall comply with CBC Section 11B-703.2.7.
 - 1) 11B-703.2.8 Line spacing. Spacing between the baselines of separate lines of raised characters within a message shall be 135 percent minimum and 170 percent maximum of the raised character height.
 - f. Format: Text shall be in a horizontal format. CBC 11B-703.2.9.
 - g. Braille: It shall be contracted (Grade 2) and shall comply with CBC Sections 11B-703.3 and 11B-703.4. Braille dots shall have a domed and rounded shape and shall comply with CBC Table and Figure 11B-703.3.1.
 - h. Mounting height: Tactile sign on signs shall be located 48 inches minimum to the baseline of the lowest Braille cells and 60 inches maximum to the baseline of the

- highest line of raised characters above the finish floor or ground surface. CBC Section and Figure 11B-703.4.1.
- i. Mounting location: A tactile sign shall be located per CBC Section and Figure 11B-703.4.2 as follows:
 - 1) alongside a single door on the latch side.
 - 2) on the inactive leaf of a double door with one active leaf.
 - 3) to the right of the right hand door at double doors with two active leaves.
 - 4) on the nearest adjacent wall where there is no wall space at the latch side of a single door or at the right side of double doors with two active leaves.
 - 5) so that a clear floor space of 18 x 18 inch minimum, centered on the tactile characters, is beyond the arc of any door swing between the closed position and 45 degree open position.
 - j. Visual characters shall comply with CBC Section 11B-703.5 and shall be 40 inches minimum above finish floor or ground.
 - 1) Visual character stroke thickness of the uppercase letter "I" shall be 10 % minimum and 20% maximum of the height of the character. CBC Section 11B-703.5.7
 - k. Pictograms shall comply with CBC Section 11B-703.6.
 - l. Symbol of accessibility shall comply with CBC Section 11B-703. 7.
 - m. Variable message signs shall comply with CBC Section 11B-703.8.
- B. Room and Door Signs: Provide a sign for every doorway, whether it has a door or not, not including corridors, lobbies, and similar open areas.
1. Sign Type: Flat signs with injection molded or etched panel media as specified.
 2. Provide "tactile" signage, with letters raised minimum 1/32 inch and Grade II braille.
 3. Character Height: 1 inch.
 4. Sign Height: 3 inches, unless otherwise indicated.
 5. Doors: Identify with room numbers to be determined later, not the numbers indicated on drawings.
 6. Conference and Meeting Rooms: Identify with room numbers to be determined later, not the numbers indicated on drawings; in addition, provide "window" section with sliding "In Use/Vacant" indicator.
 7. Service Rooms: Identify with room names and numbers to be determined later, not those indicated on drawings.
 8. Rest Rooms: Identify with pictograms, the names "MEN" and "WOMEN", room numbers to be determined later, and braille.
 - a. Identify all single user toilet facilities as gender neutral facilities by a door symbol that complies with CBC Sections 11B-216.8 and 11B-703.7.2.6.3.
 - 1) No pictogram, text, or braille is required.
 - 2) Tactile jamb signage shall comply with appropriate technical requirements of CBC Section 11B-703.
 - (a) Examples of appropriate designations are "ALL-GENDER RESTROOM", "RESTROOM", or "UNISEX RESTROOM". DSA BU-17.

- (b) Provide "RESTROOM" as the signage text, unless indicated otherwise on Drawings.
 - 3) See Drawings for actual sign to be provided.
- b. Geometric Symbols: The symbol color shall contrast with door or wall.
 - 1) Comply with CBC 11B-216.8.1 at the entrances to toilet and bathing rooms.
 - 2) Comply with CBC 11B-703.7.2.6.
 - (a) Men's: An equilateral triangle, ¼ inch thick edges with edges 12 inches long and a vertex pointing upward.
 - (b) Women's: A circle, ¼ inch thick and 12 inches in diameter.
 - (c) Unisex: A circle, ¼ inch thick and 12 inches in diameter with a equilateral triangle, ¼ inch thick edges with edges 12 inches long and a vertex pointing upward, superimposed on and geometrically inscribed within the circle and within the 12 inch diameter. The vertex of the triangle shall be located ¼ inch from the edge of the circle. The triangle shall contrast with the circle symbol, either light on a dark background or dark on a light background. The circle symbol shall contrast with the door.
 - (1) No pictogram is to be provided.
 - (d) Mount within 1 inch of the centerline of the door at minimum 58 inches and 60 inches maximum from the centerline of the symbol to the finished floor surface.
- 9. Exits: Provide raised character and Braille exit signs per CBC Section 1013.4 at the following locations:

<u>Location</u>	<u>Text</u>
Grade level exit door	EXIT

- C. Emergency Evacuation Maps:
 - 1. Allow for one map per building.
 - 2. Map content to be provided by District.
 - 3. Use clear plastic panel silk-screened on reverse, in brushed aluminum frame, screw-mounted.

2.03 SIGN TYPES

- A. Flat Signs: Signage media without frame.
 - 1. Edges: Square.
 - 2. Corners: Square.
 - 3. Clear Cover: For customer produced sign media, provide clear cover of polycarbonate plastic, glossy on back, non-glare on front.
 - 4. Wall Mounting of One-Sided Signs: Tape adhesive.
 - a. Provide visually matching back plate when mounted on a glass surface.
- B. Color and Font: Unless otherwise indicated:
 - 1. Character Font: Helvetica, Arial, or other sans serif font.
 - 2. Character Case: Upper case only.
 - 3. Background Color: As scheduled.

4. Character Color: Contrasting color.

2.04 TACTILE SIGNAGE MEDIA

- A. Etched Metal Panels: Zinc based panel etched through face to expose core as background color:
 1. Exterior Basis of Design Product: SignEtch™ ADA-Ready™ Sign System with requirements indicated for materials, thickness, finish colors, designs, shapes, sizes and details as manufactured by ASI Sign Systems, Inc., or approved equal.
 2. Total Thickness: 1/8 inch.
 3. Paint: Primer and urethane based color coat, of type standard with manufacturer.
 - a. U.V. resistant clear urethane top coat required for exterior applications.
 4. Fabrication:
 - a. Tactile Graphics and Text:
 - 1) Fabrication process: Provide tactile copy and grade 2 Braille raised 1/32 inch minimum from plaque first surface by manufacturer's photochemical etching.
 - 2) Provide lettering and graphics precisely formed, uniformly opaque to comply with relevant ADA regulations and requirements indicated for size, style, spacing, content, position, and colors.
 - b. Letter style[s], color[s], letter size[s] and layout position:
 - 1) As selected by Architect from manufacturer's standard letter style and color charts.
 - c. Raised text and graphic finishes: (Match Existing)
 - 1) Colors/Sheen:
 - (a) As selected by Architect from manufacturer's standard colors.
 - (b) Finish: Matte.
 - d. Text Schedule: As indicated on Drawings.
 - e. Edge Detail: Square.
 - f. Edge Finish: Brushed.
 - g. Overall panel size: As indicated on Drawings.
 - h. Recessed Graphics Color Options:
 - 1) As selected by Architect from manufacturer's standard colors.
 - i. Recessed Area Texture Options:
 - 1) Smooth paint.

2.05 NON-TACTILE SIGNAGE MEDIA

- A. Silk Screened Plastic Panels: Letters and graphics silk screened onto reverse side of plastic surface:
 1. Sign Color: Clear.
 2. Total Thickness: 1/8 inch.

2.06 ACCESSORIES

- A. Concealed Screws: Stainless steel, galvanized steel, chrome plated, or other non-corroding metal.

- B. Concealed Studs: Concealed (blind), threaded studs welded or brazed to back of sign material, screwed into back of sign assembly, or screwed into tapped lugs cast integrally into back of cast sign material.
- C. Exposed Screws: Stainless steel.
 - 1. Exposed fasteners are permitted only where specifically indicated, and shall be tamper proof stainless steel, countersunk, and may be painted or finished to match adjacent surfaces.
- D. Adhesives:
 - 1. Type recommended by the manufacturer of the material specified to be laminated or adhered.
 - 2. No adhesives that fade, discolor or delaminate as a result of proximity to sunlight or heat therefrom shall be used.
 - 3. Adhesives shall not change the color or otherwise deteriorate the materials to which they are to be applied.
 - 4. The adhesives shall be of non-staining, non-yellowing quality.
- E. Bituminous Paint: Cold-applied asphalt emulsion complying with ASTM D1187/D1187M.

PART 3 EXECUTION

3.01 EXAMINATION

- A. Verify that substrate surfaces are ready to receive work.
- B. Do not start work until deficiencies have been corrected. Start of work of this section constitutes acceptance of the surfaces.

3.02 INSTALLATION

- A. Install in accordance with manufacturer's instructions.
- B. Mounting Method:
 - 1. Mount signs to surfaces with a minimum of four countersunk tamperproof stainless steel fasteners.
 - 2. Provide anchorage where necessary for fastening signs securely in place.
 - a. Anchorage not otherwise specified or indicated shall include expansion shields and power-driven fasteners;
 - 1) when approved:
 - (a) for concrete and masonry;
 - (b) toggle or molly bolts to plaster surfaces;
 - (c) full threaded wood screws to wood doors;
 - (d) machine or metal screws to metal doors.
 - b. Provide backing plates for mounting to expanded metal substrates.
 - 3. Adhere signs to glass with adhesive.
- C. Install neatly, with horizontal edges level.
- D. Locate signs and mount at heights indicated on drawings and in accordance with ADA Standards and CBC Chapter 11B.

1. Room and Door Signs: Locate on wall at latch side of door a minimum of 48 inches to the baseline of the lowest braille cells; with baseline of highest line of raised character text at maximum 60 inches above finished floor.
 - a. Comply with CBC 11B-703.4.1
- E. Protect from damage until Date of Substantial Completion; repair or replace damaged items.

3.03 FIELD QUALITY CONTROL

- A. Inspect signs for information content, appearance, location and Braille per as noted in Section 01 45 33 - Code-Required Special Inspections.

3.04 ADJUST AND CLEAN

- A. Repair damage to signs incurred during installation. Replace signs which cannot be repaired to new condition. Clean glass, frames, and other sign surfaces, adjust hardware for proper operation.

END OF SECTION

SECTION 10 28 00
TOILET ACCESSORIES

PART 1 GENERAL

1.01 SECTION INCLUDES

- A. Under-lavatory pipe supply covers.

1.02 REFERENCE STANDARDS

- A. ADA Standards - Americans with Disabilities Act (ADA) Standards for Accessible Design.
- B. ASME A112.18.9 - Protectors/Insulators for Exposed Waste and Supplies on Accessible Fixtures.
- C. ASTM C1822 - Standard Specification for Insulating Covers on Accessible Lavatory Piping.
- D. ASTM E84 - Standard Test Method for Surface Burning Characteristics of Building Materials.
- E. ASTM G21 - Standard Practice for Determining Resistance of Synthetic Polymeric Materials to Fungi.

1.03 SUBMITTALS

- A. See Section 01 30 00 - Administrative Requirements, for submittal procedures.
- B. Product Data: Submit data on accessories describing size, finish, details of function, and attachment methods.
- C. Maintenance Materials: Furnish the following for District's use in maintenance of project:
 - 1. See Section 01 60 00 - Product Requirements, for additional provisions.

PART 2 PRODUCTS

2.01 REGULATORY REQUIREMENTS

- A. Provide toilet accessories meeting the requirements for the physically disabled of the California Building Code (CBC), Title 24 Part 2, and 2010 ADA Standards, as amended.
- B. Accessible requirements:
 - 1. Elements of sanitary facilities shall be mounted at locations in compliance with CBC Sections 11B-602 through 11B-612.
 - 2. Grab bars in toilet facilities and bathing facilities shall comply with CBC Section 11B-609.
 - a. Grab bars and any wall or other surfaces adjacent to grab bars shall be free of sharp or abrasive elements and shall have rounded edges.
 - b. The space around the grab bars shall be as follows:
 - 1) 1-1/2 inches between the grab bar and the wall. CBC Section 11B-609.3.
 - 2) 1-1/2 inches minimum between the grab bar and projecting objects below and at the ends.
 - 3) 12 inches minimum between the grab bar and projecting objects above.
 - 3. Toilet accessories required to be accessible shall be mounted with any operable part at maximum 40 inches above the finish floor. CBC Section 11B-603.5.

4. The grab bar shall not project more than 3 inches into the 48 inches minimum clear space required required in front of the water closet. CBC 11B-609.3.
5. Toilet tissue dispensers are to be continuous flow type. CBC Section 11B-604.7.
6. All other accessories shall not project more than 4 inches from wall surface, but cannot encroach into any required clear space.

2.02 UNDER-LAVATORY PIPE AND SUPPLY COVERS

- A. Under-Lavatory Pipe and Supply Covers:
 1. Insulate exposed drainage piping, including hot, cold, and tempered water supplies under lavatories or sinks to comply with ADA Standards.
 2. Exterior Surfaces: Smooth non-absorbent, non-abrasive surfaces.
 3. Construction: 1/8 inch flexible PVC.
 - a. Surface Burning Characteristics: Flame spread index of 25 or less and smoke developed index of 450 or less, when tested in accordance with ASTM E84.
 - b. Comply with ASTM C1822, type indicated.
 - c. Comply with ASME A112.18.9.
 - d. Microbial and Fungal Resistance: Comply with ASTM G21.
 4. Color: White.
 5. Fasteners: Reusable, snap-locking fasteners with no sharp or abrasive external surfaces.
 6. Products:
 - a. Bobrick Washroom Equipment, Inc.; www.bobrick.com.
 - b. Bradley Corporation : www.bradleycorp.com.
 - c. IPS Corporation Lav Guard 2 Undersink Pipe Covers: www.ipscorp.com.
 - d. IPS Corporation TrueBro Lav Shield: www.ipscorp.com.
 - e. Plumberex Specialty Products, Inc; Plumberex Pro-Extreme: www.plumberex.com/#sle.
 - f. Substitutions: See Section 01 60 00 - Product Requirements.

PART 3 EXECUTION

3.01 EXAMINATION

- A. Verify existing conditions before starting work.
- B. Verify exact location of accessories for installation.

3.02 INSTALLATION

- A. Install accessories in accordance with manufacturers' instructions in locations indicated on drawings.

3.03 PROTECTION

- A. Protect installed accessories from damage due to subsequent construction operations.

END OF SECTION

SECTION 26 05 00
COMMON WORK RESULTS FOR ELECTRICAL

PART 1 - GENERAL

1.01 SCOPE

- A. Work Included: All labor, materials, appliances, tools, equipment, facilities, transportation, and services necessary for and incidental to performing all operations in connection with furnishing, delivery and installation of the work of this Section, complete, as shown on the Drawings and/or specified herein. Work includes, but is not necessarily limited to, the following:
 - 1. Examine all other Sections for work related to those other Sections and required to be included as work under this Section.
 - 2. Electrical General Provisions and Requirements for electrical work.
 - 3. Division-1; General Requirements; General Conditions.
- B. Organization of the Specifications into Divisions, Sections and Articles, and arrangement of Drawings shall not control the Contractor in dividing the Contract Work among subcontractors or in establishing the extent of work to be performed by any trade.

1.02 GENERAL SUMMARY OF ELECTRICAL WORK

- A. The Specifications and Drawings are intended to cover a complete installation of systems. The omission of expressed reference to any item of labor or material for the proper execution of the work in accordance with present practice of the trade shall not relieve the Contractor from providing such additional labor and materials.
- B. Refer to the Drawings and Shop Drawings of other trades for additional details, which affect the proper installation of this work. Diagrams and symbols showing electrical connections are diagrammatic only. Wiring diagrams do not necessarily show the exact physical arrangement of the equipment.
- C. Before submitting a bid, the Contractor shall become familiar with all features of the Building Drawings and Site Drawings, which may affect the execution of the work. No extra payment will be allowed for failure to obtain this information.
- D. If there are omissions or conflicts between the Drawings and Specifications, clarify these points with the District's Representative before submitting bid and before commencing work.
- E. Provide work and material in conformance with the Manufacturer's published recommendations for respective equipment and systems.

1.03 LOCATIONS OF EQUIPMENT

- A. The Drawings indicate diagrammatically the desired locations or arrangements of conduit runs, outlets, equipment, etc., and are to be followed as closely as possible. Proper judgment must be exercised in executing the work so as to secure the best possible installation in the available space and to overcome local difficulties due to space limitations or interference of structure conditions encountered.
- B. Where outlets are placed on a wall, locate symmetrically with respect to each other, furniture, cabinets, and other features or finishes on the wall.

- C. In the event changes in the indicated locations or arrangements are necessary, due to developed conditions in the building construction or rearrangement of furnishings or equipment, such changes shall be made without cost to the Contract, providing the change is ordered before the conduit runs, etc., and work directly connected to same is installed and no extra materials are required.
- D. Lighting fixtures in mechanical spaces are shown in their approximate location only. Do not install light outlets or fixtures until mechanical piping and ductwork is installed; then install lights in a location to provide best lighting.
- E. Coordinate and cooperate in every way with other trades in order to avoid interference and assure a satisfactory job.
- F. The location of the existing utilities, building, equipment and conduit shown on the Drawings is approximate. Verify exact locations and routing of existing systems by potholing all trench routes prior to digging the trench. Pothole at least 100 feet ahead of the actual trenching to allow space to alter the new conduit routing to accommodate existing conditions.
- G. Underground Detection Services Existing Utility Structures
 - 1. Detection/location services shall be provided utilizing the latest detection equipment available. Services shall be performed by a company regularly engaged in the business of existing Underground Utility Structure Detection for the past 5-years.
 - 2. Prior to excavation and prior to directional boring the following work shall be performed:
 - a. Contractor to mark excavating and trenching/ directional boring locations and indicate width and depth.
 - b. Locate, by way of vertical and horizontal control dimensions, existing subgrade petroleum product pipes, process piping, conduits, sewer, water, gas, storm drain, electrical, telephone and irrigation lines in the affected areas of contract construction work.
 - c. Arrange and meet with the District's Representative to review existing underground conditions.
 - d. The proposed route of each excavation shall be continuously surveyed along the entire excavation path using Ground-Penetrating Radar (GPR) operating from the surface grade. The GPR shall detect and map existing underground metal and non-metal, both private and public utility lines, pipes, conduits, conductors, etc. The GPR shall identify the horizontal and vertical location of existing underground conditions located at a depth of up to 3-meters below finish grade and located with a vertical and horizontal accuracy within ± 12 -inches of actual condition. The Contractor shall add this information to the existing Conditions Site Plan.
 - 3. Exercise extreme caution in directional boring, excavating and trenching on this site to avoid existing underground utilities and structures, and to prevent hazard to Personnel and/or damage to existing underground utilities or structures. The Contract Documents, Drawings and Specifications do not include necessary components for construction safety, which is the responsibility of the Contractor.
 - 4. Repair/replace, without additional cost to the Contract, and to the satisfaction of the District any existing work damaged that was identified in the Record Drawings provided; Identified by the District's Representative; Identified by the Underground Detection

Services performed; or any existing work damaged as a result of failure to comply with all the referenced Requirements.

5. The Contractor shall contact Common Ground Alliance (CGA) telephone #811 "Know What's Below-Call Before You Dig" and Underground Service Alert (USA), not less than 72-hours prior to excavation. Contractor shall not excavate until verification has been received from CGA and USA that existing underground utilities serving the site have been located, identified, and marked.
- H. The locations of existing underground utilities, where shown on Drawings, are shown diagrammatically and have not been independently verified by the District, the District's Representative, the Architect/Engineer. The District, the District's Representative, and the District's Architect/Engineer are not responsible for the location of underground utilities or structures, whether or not shown or detailed and installed under this or any other Contracts. The Contractor shall identify each existing utility line prior to excavation and mark the locations on the ground of each existing utility line.

1.04 AIR CONDITIONING, HEATING, PLUMBING EQUIPMENT WIRING

Provide electrical work, materials, and control components required for proper operation of the air conditioning, heating and plumbing systems as indicated on the Electrical, Mechanical, and Plumbing Contract Documents and specified herein.

1.05 PERMITS

Take out and pay for all required permits, inspections, and examinations without additional cost to the District.

1.06 QUALITY ASSURANCE

- A. Work and materials shall be in full accordance with the latest Rules and Regulations as follows. The following publications shall be included in the Contract Documents Requirements. If a conflict occurs between the following publications and any other part of the Contract Documents, the Requirements describing the more restrictive provisions shall become the applicable Contract definition:
 1. California Code of Regulations Title 24.
 2. California Part 3 "California Electrical Code" CEC, Title 24 and Title 8 "Division of Industrial Safety".
 3. California Building Code – CBC.
 4. California Fire Code – CFC
 5. The National Electrical Code – NEC/NFPA 70.
 6. International Building Code – IBC.
 7. National Fire Protection Agency – NFPA.
 8. National Fire Alarm Code – NFAC/NFPA 72.
 9. Underwriter's Laboratory – UL.
 10. Other applicable State and Local Government Agencies Laws and Regulations.

11. Electrical Installation Standards National Electrical Contractors Association (NECA) and National Electrical Installation Standards (NEIS):
 - a. NECA/NEIS-1: Standard of Practices for Good Workmanship in Electrical Construction
 - b. NECA/NEIS-101: Standard for Installing Steel Conduit (Rigid, IMC, EMT) (ANSI)
 - c. NECA/NEIS-104: Recommended Practice for Installing Aluminum Building Wire and Cable (ANSI)
 - d. NECA/NEIS-105: Standard for Installing Metal Cable Tray Systems (ANSI)
 - e. NECA/NEIS-111: Standard for Installing Nonmetallic Raceways (RNC, ENT, LFNC) (ANSI)
 - f. NECA/NEIS-230: Recommended Practice for Installing Motors
 - g. NECA/FOA-301: Standard for Installing and Testing Fiber Optic Cables
 - h. NECA/NEIS-305: Standard for Fire Alarm System Job Practice (ANSI)
 - i. NECA/NEIS-331: Standard for Installing Building and Service Entrance Grounding
 - j. NECA/NEIS-400: Standard for Installing and Maintaining Switchboards
 - k. NECA/NEIS-402: Standard for Installing and Maintaining Motor Control Centers (ANSI)
 - l. NEIS/NECA and EGSA-404: Standard for installing Generator Sets (ANSI)
 - m. NECA/NEIS-405: Recommended Practices for installing and Commissioning Interconnected Generation Systems
 - n. NECA/NEIS-407: Recommended Practice for Installing Panelboards
 - o. NECA/NEIS-408: Standards for Installing and Maintaining Busways (ANSI)
 - p. NECA/NEIS-409: Recommended Practice for Installing and Maintaining Dry-Type Transformers
 - q. NEIS/NECA and IESNA-500: Recommended Practice for installing indoor Commercial Lighting Systems
 - r. NEIS/NECA and IESNA-501: Recommended Practice for Installing Exterior Lighting Systems
 - s. NEIS and IESNA-502: Recommended Practice for Installing Industrial Lighting Systems
 - t. NECA/BICSI-568: Standards for Installing Commercial Building Telecommunications System
 - u. NECA/MACSCB 600: Standard for Installing and Maintaining Medium-Voltage Cable (ANSI)
- B. All material and equipment shall be new and shall be delivered to the site in unbroken packages. All material and equipment shall be listed and labeled by Underwriters Laboratories or other recognized testing laboratories, where such listings are available. Comply with all Installation Requirements and restrictions pertaining to such listings.
- C. Work and material shown on the Drawings and in the Specifications is new and included in the Contract unless specifically indicated as existing or N.I.C. (not in Contract).

- D. Keep a copy of all applicable Codes and Standards available at the Job site at all times for reference while performing work under this contract. Nothing in Plans or Specifications shall be construed to permit work not conforming to the most stringent of building codes.
- E. Where a conflict or variation occurs between applicable Codes, Standards and/or the Contract Documents, the provisions of the most restrictive provision shall become the Requirement of the Contract Documents.

1.07 SUBMITTALS (ADDITIONAL REQUIREMENTS)

A. General

- 1. Review of Contractor's submittals is for general conformance with the design concept of the Project and general compliance with the information given in the Contract Documents. Any action shown is subject to the Requirements of the Plans and Specifications. Contractor is responsible for quantities; dimensions which shall be confirmed and correlated at the job site; fabrication processes and techniques of construction; coordination of work with that of all other trades and satisfactory performance of their work.
- 2. The Contractor shall review each submittal in detail for compliance with the Requirements of the Contract Documents prior to submittal. The Contractor shall "Ink Stamp" and sign each item of the submittal with a statement "CERTIFYING THE SUBMITTAL HAS BEEN REVIEWED BY THE CONTRACTOR AND COMPLIES WITH ALL THE REQUIREMENTS OF THE CONTRACT DOCUMENTS". The Contractor shall clearly and specifically identify each individual proposed substitution, substitution of equal or proposed deviation from the Requirements of the Contract Documents with a statement "THIS ITEM IS A SUBSTITUTION".

The burden of research, preparation of calculations and the furnishing of adequate and complete Shop Drawings information to demonstrate the suitability of Contractor's proposed substitutions and suitability of proposed deviations from the Contract Documents is the responsibility of the Contractor.

- 3. Departure from the submittal procedure will result in resubmittals and delays. Failure of the Contractor to comply with the submittal Requirements shall render void any acceptance or any approval of the proposed variation. The Contractor shall then be required to provide the equipment or method without variation from the Contract Documents and without additional cost to the Contract.
- 4. The Contractor at no additional cost or delays to the Contract shall remove any work, material and correct any deficiencies resulting from deviations from the Requirements of the Contract Documents not approved in advance by the District prior to commencement of work.
- 5. Shop Drawings submitted by the Contractor, which are not specifically required for submittal by the Contract Documents, or Contractor Shop Drawings previously reviewed and resubmitted without a written resubmittal request to the Contractor, will not be reviewed, considered, or commented on. The respective Shop Drawing submittal/ resubmittal will not be returned to the Contractor and will be destroyed without comment or response to the Contractor. The respective submittal shall be considered null and void as being not in compliance with the Requirements of the Contract Documents.

6. Refer to Division-1 for Additional Requirements.

B. Material Lists and Shop Drawings

1. Submit Material list and Equipment Manufacturers for review within 35 days of award of Contract. Give name of Manufacturer and where applicable, brand name, type and/or catalog number of each item. Listing of more than one Manufacturer for any one item of equipment, or listing items "as specified", without both make and model or type designation, is not acceptable. Shop Drawings shall not be submitted before review completion of Manufacturers list. The right is reserved to require submission of samples of any material whether or not particularly mentioned herein.
2. After completion of review of the Material and Equipment Manufacturers list, submit Shop Drawings for review. Shop Drawings shall be submitted in completed bound groups of materials (i.e., all lighting fixtures or all switchgear, etc.). The Contractor shall verify dimensions of equipment and be satisfied as to fit and that they comply with all Code Requirements relating to clear working space about electrical equipment prior to submitting Shop Drawings for review. Submittals, which are intended to be reviewed as substitution or departure from the Contract Documents, must be specifically noted as such. The Requirements of the Contract Documents shall prevail regardless of the acceptance of the submittal.
3. Shop Drawings shall include catalog data sheets, instruction manuals, Dimensioned Plans, elevations, details, wiring diagrams, and descriptive literature of component parts where applicable. Structural calculations and mounting details, signed by a Structural Engineer registered by the State of California, shall be submitted for all equipment weighing over four hundred pounds, and shall be in compliance with Title 21 of the California Code of Regulations.
4. Each Shop Drawing item shall be identified with the Specification Section and paragraph numbers, lighting fixture types and Drawing sheet numbers; the specific Shop Drawing is intended to represent. Shop Drawings 11-inches by 17-inches or smaller in size shall be bound in three ring binders. Divider tabs shall be provided in the three ring binders identifying and separating each separate Shop Drawing submittal item. Shop Drawings larger than 11-inches by 17-inches, Shop Drawing pages/sheets submittals shall be sequentially numbered with unique alphanumeric numbering system to facilitate correspondence referencing identification of individual sheets.
5. The time required to review and comment on the Contractor's submittals will not be less than 14 calendar days, after receipt of the submittals at the office of FBA Engineering. The review of Contractor submittals and return to Contractor of submittals with review comments will occur in a timely manner conditioned upon the Contractor complying with all of the following:
 - a. The submittals contain complete and accurate information, complying with the Requirements of the Contract Documents.
 - b. Contractor's submittals are each marked with Contractor's approval "stamp", and with Contractor signatures.
 - c. The submittals are received in accordance with a written, shop drawing submittal schedule for each submittal. The Contractor distributes the schedule not less than 35-calendar days in advance of the Shop Drawing Submittals, and the schedule

identifies the calendar dates, the Contractor will deliver the various submittals for review.

6. Shop Drawings shall include the Manufacturers projected days for shipment from the factory of completed equipment, after the Contractor releases the equipment for production. It shall be the responsibility of the Contractor to ensure that all material and equipment is ordered in time to provide an orderly progression of the work. The Contractor shall notify the District's Representative of any changes in delivery, which would affect the Project completion date.
7. Submittal Identification
 - a. Each submittal shall be dated: with submittal transmission date; sequentially numbered and titled with submittal contents identification and applicable Specification/Drawing references (*i.e., Submittal dated: 05/12/98 Submittal #4 Contents: Branch Circuit Panelboards Sheet #E5.1 and Transformers Specification Section 260500 Paragraph 2.11, etc.*).
 - b. Each resubmittal shall be dated: with original submittal date and resubmittal transmission dates; sequentially numbered with original submittal number and sequential resubmittal revision number and titled with submittal contents identification and applicable Specifications/Drawing references (*i.e., Original Submittal Date: 05/12/98 Resubmittal Date: 10/09/98 Original Submittal #4 Resubmittal Revision R2 Contents: Transformer Resubmittal Specification Section - 260500 Paragraph 2.11, etc.*).
 - c. Contractor shall provide a written response narrative with each resubmittal. Describe each response-action, resubmittal addition, change and deletion. Correspond to each response to A/E specific review comment.
- C. The Contractor shall be responsible for incidental, direct and indirect costs resulting from the Contractor's substitution of; or changes to; the specified Contract Materials and Work.
- D. The Contractor shall pay, upon request by the District's Representative, a fee for the District's Representative time involved in the review of substitution submittals and design changes resulting from the Contractor's requested substitutions. The fee shall be not less than \$125.00 per hour but, in no case, less than stated in Division-1, whichever is greater.
- E. Maintenance and Operating Manuals
 1. The Contractor shall furnish three copies of type-written maintenance and operating manuals for all electrical equipment, fire alarm equipment, sound system equipment, etc., to the District.
 2. Instruct the District's Personnel in correct operation of all equipment at completion of Project. Provide the quantity and duration of instruction class as specified; but in no case less than two 4-hour duration separate instruction classes for each individual equipment group furnished as part of the Contract. Instruction classes shall be presented by Manufacturer's authorized field service Engineer at the project site. Instruction class size shall be at the District's discretion, not less than one or more than fifteen students shall attend each instruction session. Submit fifteen written outline copies of the proposed instruction class curriculum, 14-days prior to the class-scheduled dates.

3. Maintenance and operating manuals shall be bound in three-ring, hard-cover, plastic binders with table of contents. Manuals shall be delivered to the District's Representative, with an itemized receipt.
- F. Portable or Detachable Parts: The Contractor shall retain in his possession and shall be responsible for all portable and detachable parts or portions of the installation such as fuses, keys, locks, adapters, locking clips, and inserts until final completion of Contract Work. These parts shall then be delivered to the District's Representative with an itemized receipt.
- G. Record Drawings (Additional Requirements)
1. Provide and maintain in good order a complete set of Electrical Contract "Record" prints. Changes to the Contract to be clearly recorded on this set of prints. At the end of the Project, transfer all changes to one set of transparencies to be delivered unfolded to the District's Representative.
 2. The actual location and elevation of all buried lines, boxes, monuments, vaults, stub-outs and other provisions for future connections shall be referenced to the building lines or other clearly established base lines and to approved benchmarks. If any necessary dimensions are omitted from the Record Drawings, the Contractor shall, at the Contractor's own expense, do all excavation required to expose the buried work and to establish the correct locations.
 3. The Contractor shall keep the "Record" prints up to date and current with all work performed.
 4. Refer to Division-1 for Additional Requirements.

1.08 CLEANING EQUIPMENT, MATERIALS, PREMISES

All parts of the equipment shall be thoroughly cleaned of dirt, rust, cement, plaster, etc., and all cracks and corners scraped out clean. Surfaces to be painted shall be carefully cleaned of grease and oil spots and left smooth, clean and in proper condition to receive paint finish.

1.09 JOB CONDITIONS - PROTECTION

Protect all work, materials, and equipment from damage from any cause whatever and provide adequate and proper storage facilities during the progress of the work. Provide for the safety and good condition of all the work until final acceptance of the work by the District and replace all damaged or defective work, materials, and equipment before requesting final acceptance.

1.10 EXCAVATION, CUTTING, BACKFILL AND PATCHING ADDITIONAL REQUIREMENTS

- A. General
1. Perform excavation, cutting, backfill, core drilling, directional boring, and patching of the construction work required for the proper installation of the electrical work.
 2. Patching shall be of the same material, thickness, workmanship, and finish as existing and accurately match-surrounding work to the satisfaction of the District's Representative.
 3. Prior to penetrating, coring, drilling or cutting existing building elements, concrete and/or masonry, provide imaging equipment examinations of each specific location. The imaging process shall identify existing internal embedded components and locations, including structural elements/anchors, conduit, and piping that are present. Do not

penetrate or damage the existing internal embedded elements. Imaging shall employ one of the following, with GPR methodology preferred:

- a. Non-invasive imaging employing high frequency, ground penetrating radar (GPR), single side echo reflection technology.
- b. Non-invasive imaging employing x-ray radiography, through-and-through imaging technology.

B. Excavation Temporary Cover

1. Excavations for Contract Work occurring in streets, vehicular drive areas, parking lots, sidewalks; any paved surface; or any area accessible to the public; provide temporary steel plating and shoring support for the plates, to completely cover the excavations under one or more of the following conditions:
 - a. Excavation shall not remain "open" for more than 4-calendar days; provide temporary plating.
 - b. Excavation shall not be "open" over weekends (Saturday, Sunday) or Holidays; provide temporary plating.
2. The temporary plating shall be a minimum of 0.75-inch thickness steel, but in no case shall the thickness be less than required to support AASHO-H20 traffic loading.
3. Provide a minimum of two 100% open lane(s) (12-foot lane width) for vehicular traffic at all times during construction, for vehicle access to all areas.

1.11 IDENTIFICATION

A. Equipment Nameplates

1. Panelboards, terminal cabinets, circuit breakers, disconnect switches, starters, relays, time switches, contactors, push-button control stations, and other apparatus used for the operation or control of feeders, circuits, appliances, or equipment shall be properly identified by means of descriptive nameplates or tags permanently attached to the apparatus and wiring.
2. Provide nameplate label on electrical service entrance equipment describing available short circuit information calculated by the Contractor, including:
 - a. Calculation date, month-day-year.
 - b. Calculate maximum available short circuit fault current.
 - c. Description of parameters and changes affecting the Requirements for recalculation of the fault current information.
3. Electrical equipment including switchgear, switchboards, electric panels and control panels, motor control centers, combination motor starters, transformers, disconnects, etc., shall each be labeled by the Manufacturer with "Electric-Arc-Flash" warning signs. The signs shall explain a hazard to personnel may exist if the equipment is worked on while energized or operated by personnel while energized. The sign shall instruct personnel to wear the correct protective equipment/clothing (PPE) when working "Live" or operating "Live" electrical equipment and circuits.
4. Nameplates shall be engraved laminated phenolic. Shop Drawings with dimensions and format shall be submitted before installation. Attachment to equipment shall be with

escutcheon pins, rivets, self-tapping screws or machine screws. Self-adhering or adhesive backed nameplates shall not be used.

5. Provide black-on-white laminated plastic nameplates engraved in minimum ¼-inch high letters to correspond with the designations on the Drawings. Provide other or additional information on nameplates where indicated.
- B. Plates: All cover and device plates shall be furnished with engraved or etched designations under any one of the following conditions (minimum character size not less than 0.188 inch. Engraving shall indicate circuits and equipment controlled or connected):
1. More than two devices under a common coverplate.
 2. Lock switches.
 3. Pilot switches.
 4. Switches in locations from which the equipment or circuits controlled cannot be readily seen.
 5. Manual motor starting switches.
 6. Where so indicated on the Drawings.
 7. As required on all control circuit switches, such as heater controls, motor controls, etc.
 8. Receptacles other than standard 15-amp 120 volt duplex receptacles; shall indicate circuit voltage, ampere, phase and source circuit number.
 9. Where outlets or switches are connected to emergency power circuit; provide panel-board and circuit number engraved on plate.
 10. Low voltage and signal system outlets.
- C. For equipment and access doors or gates to equipment containing or operating on circuits of more than 100 volts AC or DC nominal. Provide red-on-white laminated warning signs engraved in ½-inch high letters to read: "DANGER - 480 (*or applicable voltage*) VOLTS KEEP OUT AUTHORIZED PERSONNEL ONLY".
- D. Wire and Cable Identification
1. Provide identification on individual wire and cable including signal systems, fire alarm, electrical power systems (each individual phase, neutral and ground), empty conduit pull ropes, and controls circuit.
 2. Permanent identification shall be provided at each termination location, splice location, pullbox, junction box and equipment enclosure.
 - a. Individual wire and cable larger than #6AWG or 0.25-inch diameter, shall be provided with polypropylene identification tag holders, with yellow polypropylene tags interchangeable black alphanumeric characters, character height 0.25 inch. Attach identification tags with plastic "tie" wraps, minimum of two for each tag. As manufactured by Almetek Industries- "EZTAG" series; or TECH Products - "EVERLAST" series.
 - b. Individual wire and cable #6AWG and smaller or smaller than 0.25 inch diameter, shall be provided with water and oil resistant, flexible, self-laminating pressure sensitive machine embossed plastic tags that wrap a minimum of 360 degrees around the wire/cable diameter. The entire tag shall then be covered with a clear flexible waterproof plastic cover wrapped a minimum of 540 degrees around the

wire/cable diameter and completely covering the identification. As manufactured by Brady Identification; or 3M; or Panduit.

- c. Each identification tag location shall indicate the following information: circuit number, circuit phase, source termination and destination termination equipment name (or outlet number as applicable).
3. Install permanent identification after installation/pulling of wire/cable is complete, to prevent loss or damage to the identification.
- E. Cardholders and cards shall be provided for circuit identification in panelboards. Cardholders shall consist of a metal frame retaining a clear plastic cover permanently attached to the inside of panel door. List of circuits shall be typewritten on card. Circuit description shall include name or number of circuits, area, and connected load.
- F. Junction and pull boxes shall have covers stenciled with box number when shown on the Drawings, or circuit numbers according to panel schedule. Data shall be lettered in a conspicuous manner with a color contrasting to finish.

1.12 TESTING

- A. The Contractor shall obtain an independent testing laboratory, provide all instrumentation and perform tests on the electrical system and equipment as hereinafter described and further directed by the District's Representative. The test shall be performed after the completion of all electrical systems included in the Contract Scope of Work. All tests shall be recorded and documented and submitted to the District's Representative for review.
 1. All equipment and personnel required for set-up and testing shall be provided by the Contractor.
- B. Test for Phase to Ground and Neutral Condition:
 1. Open main service disconnects.
 2. Isolate the system neutral from ground by removing the neutral disconnects link located in the service switchboard.
 3. Close all submain disconnects.
 4. Close all branch feeder circuit breakers.
 5. Turn all switches to "on" position, unplug all portable equipment from outlet receptacles.
 6. Measure the resistance of each phase to ground and phase to neutral. A properly calibrated "megger" type test instrument shall be used. The test voltage shall be a nominal 500 volts.
 7. Record all readings after 1-minute duration and document into a complete report.
 8. Isolating Grounds: In the event that low resistance ground neutral connections are found in the system, they shall be isolated and located by testing each circuit individually as outlined above. Make proper corrections to restore the resistance values to an acceptable value.

- C. Method of obtaining ground resistance shall be in accordance with the latest edition of the James G. Biddle (Plymouth Meeting, Pennsylvania) manual published on this subject.
 - 1. Perform "fall-of-potential" three-point tests on the main grounding electrode of system per IEEE Standard No. 81, Section 8.2.1.5. when suitable locations for test rods are not available, a low resistance dead earth or reference ground shall be utilized.
 - 2. Perform the two-point method test per IEEE Standard No. 81, Section 8.2.1.1, to determine the ground resistance between the main grounding system and all major electrical equipment frames, system neutral, and/or derived neutral points.
- D. The testing, calibrating and setting of all ground and ground fault equipment, circuit breakers, circuit device protection relays, and meters adjustable settings shall be by an independent testing laboratory. Set as recommended by the respective Manufacturer and coordination study so as to be coordinated with other protection devices within the electrical design. Bound and tabulated copies of the test and settings shall be sent to the District's Representative.
- E. Ampere and Voltage Measurements
 - 1. Measure and record ampere and line voltage measurements under full load on all panel feeders, switchboard, and switchgear feeders, motor control centers and motor circuits provided in the Contract. Record measurements at the equipment tested and submit to the District's Representative for review.
 - 2. Ampere voltage readings shall be:
 - a. Phase A-B, A-C and B-C.
 - b. Phase A-Neutral, B-Neutral and C-Neutral.
 - 3. The ampere and voltage readings shall be not less than 20-minutes duration for each test. Record and submit the measured minimum, maximum and 20-minute average for each ampere and voltage value and test location. Voltage and ampere measurements shall occur at the connected load end of each respective feeder, not at the source of supply end of each feeder.
 - 4. Test equipment shall be accurate within plus or minus 1%.
 - 5. Branch circuit devices 40 amp or less and motor loads ten horsepower or smaller are excluded from ampere and voltage testing Requirement.
 - 6. If, in the opinion of the District's Representative, the voltages and regulations are not met within acceptable limits, make arrangements with the serving utility for proper electrical service. Retest feeder line voltages, and submit to District's Representative for review, after the utility company has completed corrective actions. Reset "voltage taps" on transformers provided or modified as part of the contract work, to adjust line voltages to within acceptable values, as directed by the District's Representative.
- F. The Contractor shall complete the following work before any electrical equipment is energized.
 - 1. All equipment shall be permanently anchored.
 - 2. All bus connections and conductor/wire connections shall be tightened per Manufacturer's instructions and witnessed by the District's Representative.
 - 3. All ground connections shall be completed and identified. Perform and successfully complete all required megger and ground resistance tests.

4. Feeders shall be connected and identified.
5. The interiors of all electrical enclosures including busbars and wiring terminals shall be cleaned of all loose material and debris, paint, plaster, cleaners or other abrasives over spray removed and equipment vacuumed clean. The District's Representative shall observe all interiors before covers are installed.
6. All wall, ceiling, and floor work and painting shall be completed within areas containing electrical equipment prior to installation of equipment. The equipment indoor rooms and spaces shall be weathertight, and weather protected from environmental incursions.
7. All doors to electrical equipment rooms shall be provided with locks in order to restrict access to energized equipment.
8. Electrical spaces and rooms shall not be used as storage rooms after power is energized.
9. Outdoor electrical equipment enclosures and housings shall be weather protected.
10. The electrical system time current coordination and ARC-Fault study shall be complete for circuit breakers, ground relays set, and circuit relay sets, fuses; set-up, tested and calibrated accordingly.

1.13 POWER OUTAGES

- A. All Electrical Services in all occupied facilities of the Contract Work are to remain operational during the entire Contract period. Any interruption of the electrical services for the performance of this work shall be at the convenience of the District and performed only after consultation with the District's Representative. Work involving circuit outages shall be only at such a time and of such a duration as approved in writing. Work involving circuit outages for the work required to connect new equipment and disconnect existing equipment shall be performed at the convenience of the District.
- B. Contract Work involving outages or disruption of normal function in electrical power systems, telephone/communication systems, fire alarms, shall be performed during the following time periods. The contract work shall be phased to limit outages in the respective systems to the stated periods:
 1. 11:30 p.m. Friday to 11:30 p.m. Sunday of the same weekend. Work shall occur on multiple weekend periods if a single weekend is not sufficient time to complete the work.
 2. The contract work involving outages shall be phased in multiple work time units, to comply with the permitted outage limitations.
- C. Work involving system outages to the building fire alarm system shall be performed only after consultation with the District and shall be only at such a time and of such duration as approved in writing. Contractor shall provide continuous "Fire-Watch" during fire alarm system outages and comply with AHJ "Fire-Watch" Requirements.
- D. Provide overtime work; double shift work; nighttime work; Saturday, Sunday, and holiday work to meet outages schedule.
- E. Provide temporary electrical power to meet the Requirements of this Article.
- F. Any added costs to Contractor due to necessity of complying with this Article shall be included in the Contract Scope of Work.

- G. When electrical work involving power disruptions to existing areas is initiated, the work shall proceed on a continuous basis without stopping until electric power is restored to the affected areas.
- H. The Contractor shall request in writing to the District's Representative a minimum of 3-weeks in advance, for any proposed electrical outage.

1.14 TEMPORARY ELECTRICAL POWER

- A. Provide temporary electrical power if work requiring power outages cannot be completed in time permitted and approved by the District's Representative.
- B. Temporary electrical power shall be a standby diesel engine generator. Voltage, frequency, regulation, etc. shall be equal to that of normal utility source. Exhaust system shall have a critical silencing muffler. Generator voltage shall match the existing secondary voltage required at the site. The Contractor shall furnish all necessary cables, switches, etc., to make all required connections to existing panels, feeders, etc. Generator shall be sized to adequately carry the demand load. If record of demand load is not available, size generator to match corresponding transformer, maximum capacity circuit as directed by the District's Representative.
- C. After completion of required usage of the temporary generators, prior to completion of the Project, the Contractor shall remove the generators. All temporary cables, switches, etc. shall be removed and all permanent equipment left in satisfactory condition.
- D. Each generator shall be housed in security type sound attenuated housing to prevent access by unauthorized Personnel. Temporary power cables, connections, etc. shall be protected from unauthorized Personnel.
- E. The Contractor shall be responsible for complete operation of the generator including Personnel, fuel supplies, proper safety precautions, etc. Generator shall not be left unattended while in operation.
- F. The Contractor shall provide temporary construction lighting and power as required in areas where work is being performed. Temporary power arrangements, outages, installation, work schedules, etc., shall be submitted in writing 3-weeks prior to requested outage date, and approved by the District's Representative prior to start of work.

1.15 ASBESTOS, POLYCHLORINATED BIPHENYL (PCB) OR HAZARDOUS WASTE:

- A. It is understood and agreed that this contract does not contemplate the handling of asbestos, PCB or any hazardous waste material. If asbestos, PCB or any hazardous waste material is encountered, notify the District's Representative immediately. Do not disturb, handle or attempt to remove.
- B. Lighting Fixture Demolition Hazardous Materials
 - 1. The removal of existing lighting fixtures will generate hazardous material Waste Disposal Contract Documents.
 - a. The existing lighting fixture ballast contains PCB material.
 - b. The existing lighting fixture lamps contain mercury.
 - c. The existing lighting fixture internal wire insulation may contain asbestos.
 - 2. Remove, handle, store, contain, dispose-of and document the hazardous materials resulting from existing lighting fixtures work, as part of the Contract Requirements.

1.16 TIME/CURRENT COORDINATION, SHORT CIRCUIT, ARC-FLASH AND SERIES RATED EQUIPMENT

A. Series Rated Equipment.

1. Circuit protective Devices identified as "Series Rated" or "Current Limiting" (i.e., CLCB - current limiting circuit breaker; CLF - current limiting fuse, etc.) shall be series rated and tested (UL 489 and CSA5) by the Manufacturer with all equipment and circuit protective devices installed downstream of the identified series rated or current limiting device.
2. Provide nameplates on all equipment located downstream, including the CLCB and CLF devices, to comply with CEC/NEC paragraphs 110-22 and 240-83 "CAUTION SERIES RATED SYSTEM - NEW DEVICE INSTALLATIONS AND REPLACEMENTS SHALL BE THE SAME MANUFACTURER AND MODELS".

B. Short Circuit, Coordination and Arc-Flash

1. Perform engineering analysis and submit engineered settings for each equipment location, fuse and circuit breaker device, showing the correct time and current settings to provide the selective coordination within the limits of the specified equipment. Shall comply with the latest application standards of IEEE and ANSI. Provide electrical system short circuit worst case bolted-fault analysis, both 3-phase line-to-line and 1-phase line-to-ground calculations as part of the coordination analysis recommendations. Provide Electric Arc-Flash calculations as part of the coordination analysis recommendations.
2. The information shall be submitted in both tabular form and on time current log-log graph paper, with an engineering narrative. Written narrative describing data, assumptions, analysis of results and prioritized recommendations, six copies.
3. The goal is to minimize an unexpected but necessary electrical system outage and Personnel exposure to the smallest extent possible within the fault occurrence location, using the specified Contract Equipment shall comply with, but not limited to:
 - a. IEEE-242, Recommended Practices for Protection and Coordination of Industrial and Commercial Distribution.
 - b. IEEE-399, Recommended Practices for Industrial and Commercial Power System Analysis.
 - c. IEEE-1584, Guide to Performing Arc-Flash Hazard Study.
 - d. CEC/NEC
4. Provide permanent warning labels on each equipment location. The labels shall describe Arc-Flash, Short-Circuit and Time/Current Coordination, including safety precautions and protective clothing. Also described actions to be taken if any circuit changes or equipment modifications occur.
5. Shall be submitted with the Shop Drawing Submittals for the respective equipment.

1.17 INDEPENDENT TESTING LABORATORY

A. Testing Laboratories Definition

1. The Testing Laboratory shall meet Federal OSHA Criteria for accreditation of Nationally Recognized Testing Laboratories (NRTL) Title 29 Part 1907 and 29 CFR-1910.
2. Membership in the National Electrical Testing Association (NETA) shall also constitute acceptance of meeting said criteria, for testing of electrical systems.

1.18 SPARE FUSES

Provide three spare fuses for each size and type at each location to match the installed fuses where the fuses are provided as part of the Contract. Provide spare fuse holders on inside door of each respective fuse compartment. Provide engraved nameplate on front of fuse access door indicating fuse type/catalog number ampere rating and Manufacturer of fuse.

1.19 EQUIPMENT SEISMIC AND WIND LOAD REQUIREMENTS (ADDITIONAL REQUIREMENTS)

A. Seismic Performance and Seismic Restraint Requirements

1. Refer to Structural, Architectural, and Soils Report Contract Documents for Additional Requirements.

B. General

1. Equipment supports and anchorage is provided as part of the Contract shall be designed, constructed and installed in accordance with the Earthquake Regulations of the California Building Code (CBC), International Building Code (IBC).
2. Provide equipment anchorage details, coordinated with the equipment mounting provision, prepared, signed and "stamped" with PE registration in good standing, by a Civil or Structural Engineer licensed as a Professional Engineer (PE) in the State of California.
3. Mounting recommendations shall be provided by the Manufacturer based upon approved shake-table tests used to verify the seismic design of that type of equipment.
4. The Equipment Manufacturer shall document the details necessary for proper wind-load and seismic mounting, anchorage, and bracing of the equipment for floor, ceiling, and wall/back installation location.
5. Seismic performance shall be based on actual install location of the respective equipment in the building and height above or below grade.
6. The Seismic Requirements are typical for each equipment item exceeding 19-pounds, including but not limited to the following:
 - a. Switchgear, switchboards, and motor control equipment
 - b. Transformers
 - c. Equipment racks and terminal cabinets
 - d. Panels
 - e. Conduits with floor, ceiling or wall attachment support and conduits with suspension attachments.
 - f. Busway, wire way and cable tray
 - g. Uninterruptable Power Supplies (UPS)
 - h. Inverters
 - i. Generators and related equipment
 - j. Lighting equipment
 - k. Fire alarm equipment

C. Certification

1. Electrical Equipment Manufacturers and Contractor shall provide Special Seismic Certification (SCC) for each specific equipment configuration with shake-table verification, all furnished as part of the Contract Documents Requirements. The SCC shall include the specific installation location characteristics of the respective equipment including as follows:
 - a. Ground or floor attachment
 - b. Wall attachment
 - c. Ceiling attachment
 - d. Roof attachment
2. Wind Loading
Electrical equipment and anchorages shall withstand the wind-load imposed at the install location. Wind Loading Withstand Requirements shall apply to all electrical equipment installed in outdoor locations and to all electrical equipment exposed to the weather. The equipment shall be tested and certified by the Manufacturer and Contractor. The Wind-Load Withstand Qualification of the equipment and anchorages shall be verified by the following methods:
 - a. Aerodynamic wind tunnel test method.
 - b. Analytical calculation method, for oversized equipment too large for wind tunnel test method.
3. The wind-load withstand rating and the SCC shall comply with the Requirements of the Authority Having Jurisdiction (AHJ), and include the latest revisions, but not limited to the following:
 - a. American Society of Civil Engineers; ASCE-7
 - b. CBC/IBC; including but not limited to Sections 1702, 1708, 1709, 1708A and 1709A.
 - c. California Office of Statewide Health Planning and Development OSHPD; OPA-Preapproval of Anchorage; Code Application Notice CAN 2-1708A.5 and OSP-Special Seismic Certification Approval
 - d. US Department of Homeland Security; FEMA- (installing seismic restraints for electrical equipment)

D. Wall Mounted Electrical Equipment

1. Surface Mounted Equipment
 - a. Provide multiple horizontal sections of metal "C" channels for support and attaching wall mounted equipment to walls. Channels shall provide "turned lips" at longitudinal edges to hold "lock-in" fasteners and shall comply with ANSI-1008 and ASTM-A569 latest revision. The channels shall be steel hot dip zinc galvanized. As manufactured by Unistrut or Kindorf.
 - b. The "C" channels shall be positioned horizontally within 3-inches of the top and bottom of each, equipment section cabinet and located behind each equipment vertical section. Provide additional intermediate "C" channels at not less than 36-inches on center between the "top" and "bottom" "C" channel positions, located behind each equipment vertical section.

- c. The “C” channels shall be of sufficient length to provide connection to not less than two vertical structural wall framing elements separated by not less than 16-inches; but in no case shall the “C” channel length be less than the width of the respective equipment section.
 - d. Attach the “C” channels to the wall structural elements after the wall, finish surface, installation (including painting) is complete.
 - e. Attach the “C” channels with fasteners to the building wall framing structural elements as follows: welded to steel framing; bolted to wood framing; cast in place concrete inserts for masonry and concrete construction; drilled “afterset” expansion anchors for existing masonry and concrete construction.
 - f. Attach the equipment to the “C” channels with threaded and bolted fasteners to “pre-locate” and lock into the channel “turned lips” and channel walls.
- 2. Flush mount equipment
 - a. Provide anchor attachment of equipment into adjacent wall structural elements.
- E. Housekeeping Pad
- 1. Provide cast-in-place, steel re-enforced concrete raised “housekeeping” pads under all floor standing electrical equipment (except data network equipment racks).
 - 2. Pad sizes
 - a. The raised housekeeping pad height shall extend 4-inches above the surrounding finished floor elevation for interior building locations.
 - b. The pad shall extend 8-inches below finish grade plus 4-inches above finish grade for outdoor equipment location on grade.
 - c. The pads shall extend 7-inches past the “footprint” edge of the respective floor standing equipment.
 - 3. Anchor equipment to pads. Anchor pads to the building structural floor. Equipment pad, equipment re-enforcing and equipment anchoring shall comply with Seismic Earthquake Requirements and Wind Load Requirements.
 - 4. Unless shown otherwise on Drawings. The equipment housekeeping pad steel re-enforcing shall consist of two layers of Number-4 size steel-rebar laid horizontally and uniformly spaced 6-inches on center. Position rebar in two directions (90-degrees opposed) and centered inside the concrete housekeeping pad. Horizontal rebar shall extend to within 3-inches of the edge of the concrete pad in all directions. Metal wire “tie-wrap” shall be provided at each rebar crossing.
 - 5. Equipment anchor attachments shall extend through the housekeeping pad and into the structural concrete below the pad a minimum of not less than 2-inches.

1.20 ELECTRICAL WORK CLOSEOUT

- A. Prepare the following items and submit to the District’s Representative before final acceptance.
 - 1. Two copies of all test results as required under this Section.
 - 2. Two copies of Local and/or State Code enforcing authorities’ final inspection certificates.

3. Copies of record Drawings as required under the General Conditions, pertinent Division One Sections and Electrical General Provisions.
 4. Two copies of all receipts transferring portable or detachable parts to the District's Representative when requested.
 5. Notify the District's Representative in writing when installation is complete and that a final inspection of this work can be performed. In the event any defect or deficiencies are found during this final inspection they shall be corrected to the satisfaction of the District's Representative before final acceptance can be issued.
 6. List of spare fuses and locations identified by equipment name and building designation.
 7. Prior to energizing, retighten to the proper torque, each circuit conductor lug landing, each bus bar (phases, neutral and ground) and circuit protection device threaded connections in all switchboards, switchgear, motor control centers, transformers, busways, disconnect switches, motor starters, motor terminals and panelboards, after the equipment is installed/connected and prior to energizing the equipment. The torque values shall comply with Manufacturer's recommendations.
- B. Electrical Power Single Line Diagrams – SLD
1. Provide single line diagrams showing the Contract Document work complete electrical power system (normal and emergency). SLD shall show inter-connection circuits, electrical equipment, panels, and circuit protection devices, nominal 50% (½-size) approximately 18-inches by 24-inches. Show installed voltages and electrical capacity sizes.
 2. SLD shall be mounted in metal (picture frame) rigid enclosure frame with rigid-backing (backer-board) and clear/transparent front, for hanging on wall. Provide clear transparent cover over SLD inside the frame.
 3. Provide a wall-hung (±48-inches) SLD in each "main" and "sub" electrical equipment room. If wall space is limited, alternatively securely attach SLD frame to room door facing into the respective electrical room.

END OF SECTION 26 05 00
021821/212276

SECTION 26 05 01
BASIC ELECTRICAL MATERIALS AND METHODS

PART 1 - GENERAL

1.01 SCOPE

- A. Work Included: All labor, materials, appliances, tools, equipment, facilities, transportation, and services necessary for and incidental to performing all operations in connection with furnishing, delivery and installation of the work of this Section, complete as shown on the Drawings and/or specified herein. Work includes, but is not necessarily limited to the following:
 - 1. Examine all other Sections for work related to those other Sections and required to be included as work under this Section.
 - 2. General Provisions and Requirements for electrical work.

1.02 SUBMITTALS (ADDITIONAL REQUIREMENTS)

- A. Submit product data sheets for all outlet boxes, floor boxes, wiring devices, device plates, relays, contactors, timeswitches, and disconnects fuses.
- B. Submit detailed Shop Drawings including Dimensioned Plans, elevations, details, schematic and point-to-point wiring diagrams and descriptive literature for all component parts for relays, time clocks, and photocells.
- D. Submit material list for outlet boxes.

PART 2 - PRODUCTS

2.01 OUTLET AND JUNCTION BOXES

- A. General:
 - 1. Flush or concealed outlet boxes and junction boxes.
 - a. Non-masonry and/or non-concrete locations provide pressed steel boxes. Steel thickness not less than 0.062-inch, hot-dip galvanized. Knockout (KO) type with conduit entrances and quantity size to match conduits shown connecting to respective junction box and outlet box.
 - b. UL-514 listed and labeled.
 - c. Minimum required box depth is exclusive of extension-ring depth.
 - d. Provide all boxes with matching cover plates. Cover plates shall be gasketed water-tight in wet and outdoor locations.
 - e. Boxes installed in masonry or concrete shall be UL "concrete-tight" approved for installation in concrete and shall allow the placing of conduit without displacing reinforcing bars.
 - 2. Provide boxes of proper code size for the number of wires or conduits passing through or terminating therein. In no case shall box be less than 4.0-inches square by 2.125-inches deep, unless specified elsewhere or noted otherwise on the Drawings. 2.5-inches minimum depth for box width's exceeding 2-gang.

3. Increase the minimum outlet box size to 4.69-inches square by not less than 2.125-inches deep, where one or more of the following conditions occurs:
 - a. More than two conduits connect to the outlet box.
 - b. Circuit or Conduit "homerun" connects to outlet box.
4. Signal, Communication and Low Voltage:
 - a. Individual audio/visual, telephone, computer or data outlets: 4.69-inches square by 2.125-inch deep minimum with two gang extension ring on flush boxes.
 - b. Combination signal/telephone/data or computer outlets: 4.69-inches square by 2.125-inch deep minimum with 2-gang wide extension ring on flush boxes.
5. Junction boxes shall be sized to comply with the following:
 - a. Code Requirements size based on the conduit quantities, conduit sizes and wire-fill connected to the junction box.
 - b. Junction box minimum size shall not be less than 4.69-inches by 4.69-inches by 2.5-inches deep, but not less than size indicated on the Drawings or required by code.
6. Provide extension rings on flush outlets to finish face of extension ring flush with finished building surfaces. Extension ring shall match outlet box construction and contain "attachment mounting-tabs" for wiring devices. Extension rings shall be "screw-attached" to respective outlet box and maintain "ground" bonding continuity.
7. Outlet boxes installed in outdoor locations, or in wet locations, or in concrete/masonry, shall be cast-iron or cast bronze, with threaded conduit hubs. UL rated for wet locations.
 - a. Aluminum boxes shall NOT be in contact with concrete or masonry. Die-cast aluminum or cast aluminum water-tight electrical outlet boxes with threaded hubs may be provided as an alternate to cast-iron or cast-bronze outlet boxes, only where one or more of the following conditions occur:
 - 1) Outdoor locations above finish grade.
 - 2) Indoor wet locations surface or flush in walls or ceilings.
8. Provide fixture-supporting device in outlet boxes for surface mounted fixtures as required.
9. Provide solid gang boxes for three or more devices, typical for line and low voltage switches, receptacles, low voltage/signal outlets, etc. for mounting devices behind a common device plate.
10. Provide isolation barriers in outlet boxes:
 - a. Between line voltage and low voltage devices.
 - b. Where more than one device is installed in an outlet box.
 - c. Between 277-volt and 120-volt devices.
 - d. Between devices connected to emergency and non-emergency circuits of all volt-ages.

11. Outlet boxes installed penetrating into fire rated walls, fire rated floors, fire rated ceilings and all fire rated construction. The outlet boxes shall be UL listed, classified and labeled, for fire rated and temperature rated penetration of the respective fire rated surface and fire rated construction. The outlet box fire rating and temperature rating shall equal or exceed the fire/temperature rating of the surface/construction being penetrated. Provide UL listed and labeled supplemental fire and temperature protection to maintain ratings:
 - a. Wall and ceiling penetrations, tumescent fire wrap (external or internal of outlet box).
 - b. Floors provide subfloor supplemental fireproofing below floor box.
 12. Outlet boxes installed in floors. The floor outlet boxes shall be UL listed and labeled for Scrub Water Exclusion Requirements, including but not limited to tiles, carpeting and exposed wood and concrete floor finishes.
 13. Outdoor flush in wall device outlet boxes:
 - a. Flush in wall, gasketed watertight, with hinged, key locking cast metal, self-closing cover. Tamper resistant and vandal resistant. UL-listed and labeled for installation in masonry, cast-in-place concrete and hollow-framed walls.
 - b. Flush cast-iron or cast-bronze device back-box, 4.68-inch square by 2.25-inch deep.
 - c. Internal metal adapter plate and wiring device types, in the box as indicated on the Drawings.
 - d. As manufactured by Legrand/Pass and Seymour #4600 Series: or C.W. Cole #310 Series.
 14. Refer to Architectural and Structural Contract Documents and details for additional Box and Install Requirements.
- B. Surface Outlet Boxes
1. Surface mounted outlet boxes, cast iron Type FS or FD, with threaded hubs as required. Box interior dimensions and interior volume capacity not less than required for “press steel boxes”, and “sheet steel boxes”. Provide plugs in all unused openings. Provide weatherproof gaskets for all exterior boxes.

2.02 PULL BOXES

- A. General
1. Sizes as indicated on the Drawings and in no case of less size or material thickness than required by the Governing Code and AHJ.
 2. Exercise care in locating pull boxes to avoid installation in drain water flow areas and to clear existing condition interferences.
 3. UL listed and labeled for electrical circuits.
- B. General Purpose Sheet Metal Pullbox
1. General purpose sheet steel pull boxes: Install only in dry protected locations with removable screw covers. Manufacturer's standard rust proofing and baked enamel finishes.

2. Weatherproof sheet steel pull boxes: Fabricate of code gauge steel. All surfaces interior and exterior hot-dip galvanized steel. Gasketed weather-tight cover of same material. Manufacturer's standard baked exterior enamel finish.
- C. Concrete Pull Boxes and Hand-holes
1. H-20 traffic rated box and cover, pre-cast concrete, steel reinforced pull boxes and hand-holes. Provide complete with pulling irons, hot-dip galvanized metal traffic cover with hot-dip galvanized metal cover frame, pull-box concrete base with sump. Four cable full height wall racks with porcelain blocks.
 2. Boxes shall be "Intercept" type with multiple sections and extension cable-intercepts at both ends of box. Refer to Drawings for box size.
 3. Covers shall be flush bolt down. Covers weighing more than 40-pounds shall be split cover type "Torsion-Spring" assist, hinged open-close.
 4. Box covers shall comply with Federal ADA, UL, State and Local AHJ for slip resistance. Provide bead weld on cover to pullbox to indicate services within pull box (i.e., "480/277-VOLT, 3-PHASE, 4-WIRE ELECTRICAL" OR "SIGNAL/TEL/P.A./CLOCK/FIRE ALARM" etc.).
 5. Shall be set on a machine-compacted pea gravel base 12-inch thick and extend 6-inches beyond box base on all sides. Provide a ¾-inch by 10-foot copper clad ground rod through the box bottom with 9-inch projection into box, for grounding all metal parts with #10awg copper bond wire.
 6. After cables have been pulled, connected, tested and inspected, seal all box joints and seal box between cover and frame with a mastic compound similar to Parmagum or Dukseal.
 7. As manufactured by Jensen Precast, or Old Castle Precast.

2.03 SWITCHES

- A. General
1. Provide wiring device circuit switches totally enclosed, electrical insulating Bakelite or electrical insulating composition base, manual operator type with 277-volt 60Hz AC rating for full capacity contacts rated for incandescent lamp loads, fluorescent lamp loads and motor loads. Switch mounting ears for screw attachment to outlet box. Switches shall be UL listed and labeled; conform to NEMA-WD1 and WD6.
 2. Switch controlling (on-off) rated for all lighting loads and all non-lighting loads; switch ratings shall be 20-amp, unless indicated otherwise on Drawings.
 3. Color as selected by District's Representative. Switches controlling circuits connected to emergency power shall be red.
 4. All switches shall be of the same Manufacturer.
 5. Where switches are mounted in multiple gang assembly and are operating at 277 volts and/or 277 volts and 120 volts or emergency/non-emergency and mounted in same outlet box, there shall be an insulating barrier installed between each switch.
 6. Devices shall additionally be listed and labeled as UL-All Weather-Resistant for the following install locations:
 - a. Devices indicated on Drawings as Weather-Proof (W.P.).

- b. Devices installed in outdoor locations
 - c. Installed in classified wet or damp area locations both indoor and outdoor.
7. Wiring devices shall be listed and labeled for connection of both “solid” and “stranded” copper circuit conductors.
 8. Switches with ampere and voltage ratings different than described herein. The different rated switches shall have the same characteristics and performance as the respective described switches, except for differing ampere and voltage characteristics.

B. Switches Heavy Duty (Toggle – Type)

1. Single Pole Switches – 20 amp at 277V

<u>Manufacturer</u>	<u>Toggle Type</u>	<u>Lock Type</u>
Hubbell	#HBL1221	#HBL1221-L
Legrand/P&S	#20AC1	#20AC1-L
Leviton	#1221	#1221-L
Cooper-Arrow/Hart	#AH1221	#AH1221-L

2. Double Pole Switch – 20 amp at 277V

<u>Manufacturer</u>	<u>Toggle Type</u>	<u>Lock Type</u>
Hubbell	#HBL1222	#HBL1222-L
Legrand/P&S	#20AC2	#20AC2-L
Leviton	#1222	#1222-L
Cooper-Arrow/Hart	#AH1222	#AH1222-L

3. Three-Way Switches – 20 amp at 277V

<u>Manufacturer</u>	<u>Toggle Type</u>	<u>Lock Type</u>
Hubbell	#HBL1223	#HBL1223
Legrand/P&S	#20AC3	#20AC3-L
Leviton	#1223	#1223-L
Cooper-Arrow/Hart	#AH1223	#AH1223-L

4. Four-Way Switches – 20 amp at 277V

<u>Manufacturer</u>	<u>Toggle Type</u>	<u>Lock Type</u>
Hubbell	#HBL1224	#HBL1224-L
Legrand/P&S	#20AC4	#20AC4-L
Leviton	#1224	#1224-L
Cooper-Arrow/Hart	#AH1224	#AH1224-L

5. Momentary Contact Switches – 20 amp at 277V

<u>Manufacturer</u>	<u>3-Position Regular</u>	<u>3-Position Lock</u>
Hubbell	#HBL1557	#HBL1557-L
Legrand/P&S	#1251	#1251-L
Leviton	#1251	#1251-L
Cooper-Arrow/Hart	#AH (extra)	#AH (extra)

6. Maintained Contact Switches (Double Throw, Center Off) – 20 amp at 277V

<u>Manufacturer</u>	<u>Toggle Type</u>		<u>Lock Type</u>	
	<u>1-Pole</u>	<u>2-Pole</u>	<u>1-Pole</u>	<u>2-Pole</u>
Legrand/P&S	#1225	#1226	#12250L	#1226-L
Hubbell	#HBL1385	#HBL1386-L	#HBL1385-L	#HBLM1386-L
Leviton	#1385	#1386		
Cooper-Arrow/Hart	#AH (extra)	#AH (extra)	#AH (extra)	#AH (extra)

7. Pilot lights used in conjunction with circuit switches shall be LED type with red jewel.
- C. Weather-Proof (W.P.) Switches
 1. Outdoor switches provide heavy-duty, tamper resistant gasketed weatherproof metal, hinged door cover for each switch.
 2. Cover door shall be key locking-type or padlock-type.
- D. Other Switches, Receptacles, Devices, and Outlets
 1. Special devices outlets and outlet locations shall be as indicated on the Drawings. Modify device and outlet characteristics to accommodate the actual install location conditions for each outlet.

2.04 RECEPTACLES

- A. General
 1. All receptacle wiring devices in flush type outlet boxes shall be installed with a bonding jumper to connect the box to the receptacle ground terminal. Grounding through the receptacle mounting straps is not acceptable. The bonding jumper shall be sized in accordance with the branch circuit protective device as tabulated herein under "Grounding". Bonding jumper shall be attached at each outlet to the back of the box using drilled and tapped holes and washer head screws 6-32 or larger (except isolated ground receptacles). For receptacles in surface mounted outlet boxes direct metal-to-metal contact between receptacle mounting strap (if it is connected to the grounding contacts) and outlet box may be used. Receptacle mounting ears for screw attachment to outlet box. Receptacle shall be UL listed and labeled; conform to NEMA-WD1 and WD6.
 2. All receptacles shall be same Manufacturer.
 3. Receptacle color as selected by District's Representative. Receptacles connected to emergency power circuits shall be red.
 4. Tamper Resistant Receptacle
 - a. Devices shall additionally be listed and labeled as tamper resistant, provide tamper resistant receptacles in buildings containing dormitories, guestrooms, housing/residences, condominiums, apartments, dwellings, hotels/motels, secondary schools K through 12th grade, childcare/daycare/kindergarten, hospital pediatric-care units and other locations required by AHJ.
 - b. The electrical receptacles shall be rated "Tamper-Resistant-Receptacle" (TR), UL-TR (RTRT). Spring loaded shutters shall automatically open-close (unblock-block) the receptacle slots when the plug-in (cap) insertion and removal occurs.
 - c. Typical for 15-amp and 20-amp receptacles. Modify Manufacturer's catalog number description to include tamper resistant receptacle function.
 5. Wiring devices shall be listed and labeled for connection of both "solid" and "stranded" copper circuit conductors.
 6. Duplex convenience receptacles and 120-volt single phase branch circuits.
 - a. Duplex (convenience) receptacle, wiring device with two single receptacles with the same electrical rating, integrated into a single assembly by the Manufacturer.

- b. 20-amp branch circuits with a single duplex convenience receptacle connection on each circuit, receptacles shall be rated for 20-amp.
 - c. 15-amp and 20-amp branch circuits with two or more duplex convenience receptacle connections each circuit, receptacle shall be rated 15-amp or 20-amp.
7. Devices shall additionally be listed and labeled as UL-All Weather-Resistant, provide weather resistant receptacles for the following install locations:
- a. Devices indicated on Drawings as Weather-Proof (W.P.).
 - b. Devices installed in outdoor locations.
 - c. Devices installed in classified as damp or wet locations both indoor and outdoor.
 - d. All GFCI (ground-fault) receptacles all locations.
8. Receptacles with ampere and voltage ratings different than described for duplex convenience receptacles. The different rated receptacles shall have the same characteristics and performance as the respective duplex convenience receptacles, except for differing ampere and voltage characteristics.
9. Receptacles shall be GFCI type for the following locations:
- a. located within 84-inches of a sink or hosebib shall be GFCI receptacles.
 - b. Devices installed in outdoor locations.
 - c. Devices installed in classified as damp or wet locations both indoor and outdoor.
 - d. Devices indicated on Drawings as GFCI or Weather-Proof (W.P.).
- B. Duplex convenience receptacles.
- 1. Shall be grounding type, 120 volt and shall have two current carrying contacts and one grounding contact which is internally connected to the frame. Outlet shall accommodate standard parallel blade cap and shall be side wired. Receptacles shall be tamper resistant –TR, UL-TR.
 - 2. GFCI receptacles shall be all Weather-Resistant and wet location rated. Rated 120 volt 60Hz AC, 20 amp, unless indicated otherwise on Drawings.
 - 3. Heavy Duty Industrial Grade

<u>Manufacturer</u>	<u>NEMA 5-15R</u>	<u>NEMA 5-20R</u>	<u>NEMA 5-20R-GFCI</u>
a. Legrand/P&S	#5262	#5362	#2095HG
b. Leviton	#5262	#5362	#W7899
c. Hubbell	#CR5252	#5362	#GFR8300
d. Cooper-Arrow/Hart	#AH5262	#AH5362	#WRVGF20
- C. Weatherproof (W.P.) Receptacle
- 1. Outdoor receptacles shall be duplex convenience GFCI type rated 20-amp 120 Volt 60Hz AC weatherproof, GFCI, unless indicated otherwise on Drawings. Test-reset buttons and visual pilot.
 - 2. GFCI receptacles shall be wet location and Weather-Resistant rated weatherproof, gasketed, key locking tamper resistant, wet location.

3. Outdoor, flush mount outlet with hinged, key-locking, weather-proof cover (CEC/NEC – 406.8 compliant). As manufactured by Pass and Seymour/Legrand #4600 Series; or C.W. Cole #310 Series.
 4. On exposed conduit runs, provide weatherproof ground fault circuit interrupter type GFCI receptacles installed in "FS" conduit watertight cast metal body, with weather-proof spring door type covers, gasket watertight. Door shall be key locking-type or pad-lock-type.
- D. Other switches, receptacles, devices, and outlets.
1. Special devices, outlets and outlet locations shall be as indicated on the Drawings. Modify device and outlet characteristics to accommodate the actual install location conditions for each outlet.

2.05 PLATES

- A. Metal cover plates for devices
1. Provide cover plates for every switch, receptacle, telephone, computer, television and other device outlets. All plates shall be 0.040-inch stainless steel, Type 302 alloy composed of 18% chromium and 8% nickel. Plates shall be manufactured by P&S, Hubbell, Leviton or General Electric.
- B. Residential location project non-metal cover plates for devices.
1. Provide plates for every switch, receptacle, telephone, computer, television, and other device outlets. Non-metallic, heavy-duty, high-abuse and high-impact resistant plates. Plates shall be same Manufacturer as the respective wiring device.

2.06 VANDAL-PROOF FASTENINGS

Provide approved vandal proof type screws, bolts, nuts where exposed to sight throughout the project. Screws for such items as switch plates, receptacle plates, fixtures, communications equipment, fire alarm, blank covers, wall and ceiling plates to be spanner head stainless steel, tamperproof type. Provide District with six screwdrivers for this type.

2.07 STRUCTURAL AND MISCELLANEOUS STEEL

Structural and miscellaneous steel used in connection with electrical work and located out-of-doors or in damp locations, shall be hot dip galvanized unless otherwise specified. Included are underground pull box covers and similar electrical items. Galvanizing averages 2.0 ounce per square foot and conforms to ASTM A123.

2.08 FLASHING ASSEMBLIES

- A. General
1. Flashing shall be compatible with the material being penetrated and with the pipe passing through the flashing. Coordinate with and comply with Manufacturer's recommendations, for both the flashing and the material being penetrated.
 2. Provide lead metal flashing assemblies at all roof penetrations, unless recommended otherwise by Manufacturer.
 3. Seal the joint between the flashing and pipe passing through the flashing with waterproofing compound.

4. Lead flashing for roof penetrations, as manufactured by Santa Rosa Lead Products; or Semco; or Flashco.
- B. Storm Collars
1. In addition to penetration flashing, provide a storm-collar counterflashing for each roof penetration flashing. Shall attach to the structure of the penetration and form a water-tight “umbrella” counter flashing over the roof penetration flashing.
 2. As manufactured by STD-Storm collars; or ASI-Storm collars.

2.09 RELAYS, CONTACTORS AND TIMESWITCHES

A. Individual Control Relays (HVAC Plumbing of the Control Functions)

1. Individual control relays shall have convertible contacts rated a minimum of 10-amp, 600-volts regardless of usage voltage. Coil voltage, number and type of contacts shall be verified and supplied to suit the specific usage as shown in the wiring diagrams and/or schedules on the Electrical and Mechanical Drawings. Coil control circuit shall be independently fused, sized to protect coil. Relays shall be installed on prefabricated mounting strips. Each relay shall have a surge protection device to limit coil transient voltages. Furnished in the NEMA Type I enclosure unless indicated otherwise.
2. The following relays are approved:

<u>Manufacturer</u>	<u>Type</u>
Cooper-Arrow/Hart	IMP
General Electric	Class CR 2811
Square D Co.	Class 8501, Type A
Westinghouse	Bul. 16-321, Type NH
Allen Bradley	Approved Equal

B. Contactors and/or Relays

1. Contactors and/or relays for control of lighting shall be 600-volt AC, electrically operated, mechanically held units, open type for panel mounting with number of poles and of size as indicated on the Drawings. Provide auxiliary control relay for operation of each contactor and/or relay with a 2-wire control circuit.
2. Contactors and/or relays shall be mounted in panelboards in barriered section under separate hinged lockable doors or in contactor and/or relay cabinets as called for on the Drawings. Contactors and/or relays shall be installed on Lord sound absorbing rubber mounts.
3. Contactors and/or relays shall be Automatic Switch Co. Bulletin #920 Series for 2-pole and 3-pole, Automatic Switch Co. Bulletin 917 Series with poles as indicated on Drawings. Coil control circuit shall be independently fused, sized to protect coil.
4. Contactors and/or relays shall be equipped with a switch, in the proper configuration, to disconnect the control circuit controlling the coil of the respective device. Control circuit disconnect switch shall be labeled showing function of device.

C. Time-switches

1. All time-switches shall have synchronous motor drive for operation on 120 or 277 volts, 60Hz, AC and shall be furnished with a 10-hour, spring-driven, reserve-power motor. Contacts shall be rated 40-amp per pole.

- a. Exterior lighting time-switches for control of individual circuits or electrically operated relays shall have astronomic dial and shall be Tork 7000ZL Series or approved equal by Paragon or Intermatic.
 - b. Interior lighting time-switches for control of individual circuits or electrically operated relays shall be Tork 7000 Series or approved equal by Paragon or Intermatic.
 - c. Time-switches for control of air conditioning or plumbing equipment shall have 7-day dial and shall be Tork WL Series or approved equal by Paragon or Intermatic.
2. All time-switches shall be mounted in separate section in top of panelboards under separate lockable door unless otherwise indicated on Drawings. Clear opening for time-switch shall be a minimum of 12-inches by 12-inches.
- D. Contactors and/or Relays/Time-switch Cabinet
- 1. Contactors, relays, and/or time-switches not indicated to be mounted in electrical panels shall be mounted in a cabinet, size as required, with hinged lockable door keyed same as panelboards. Construction of cabinet shall be similar to terminal cabinets.
 - 2. Each contactor, relay or time-switch mounted in the contactor cabinet shall be barriered in its own compartment, and shall be installed on Lord sound absorbing mounts.
 - 3. Contactor cabinets shall be of the same Manufacturer as the panelboards.
 - 4. Where relays and/or contactors occupy the same enclosure as time-switches they shall have a clear acrylic shield installed over each relay or contactor to guard line exposed parts from accidental contact by non-authorized personnel.

2.10 DISCONNECTS (SAFETY SWITCHES)

- A. General
- 1. Disconnect switches shall all be rated:
 - a. 600-volt 60Hz AC for all safety switches.
 - b. NEMA Type HD, quick-make, quick-break, H.P.-rated.
 - c. Fused Class "R", in NEMA Type I enclosure, lockable.
 - d. Number of poles and amperage as indicated on the Drawings.
 - 2. Provide internal neutral bus, ground-lug and conductor landing lugs, size to match conductors shown on Drawings. Switch access door shall be interlocked with switch to prevent access inside switch when switch is "on" closed position.
 - 3. Where enclosure is indicated W.P. (Weather-Proof) switches shall be raintight NEMA Type HD and NEMA 3R enclosure, lockable.
 - 4. Maximum voltage, current and horsepower rating clearly marked on the switch enclosure and switches having dual element fuses shall have rating indicated on the nameplate.
 - 5. Switch and fuses ampere rating shall also comply with Manufacturer recommendation for the connected load.

2.11 CONCRETE WORK (ADDITIONAL REQUIREMENTS)

A. Portland Cement

1. ASTM C33- (latest revision), Type II, Low Alkali Cement. Composed of Portland cement, coarse aggregate, fine aggregate, and water.
 - a. Concrete for use as electrical equipment footings, lighting pole bases and equipment slabs on grade, concrete shall attain minimum 28-day compressive strength of 4000psi, using not less than 5.75 sacks of cement per cubic yard of wet concrete.
 - b. Concrete for underground duct/conduit encasement, the minimum 28-day compressive strength shall be 2000 psi. Provide a minimum of 10-pounds of red oxide concrete coloring per yard of concrete.
 - c. Mix shall obtain a 6-inches slump, measured with standard slump cone per ASTM C143/C143M (latest revision).
2. Coarse Aggregate: Uniformly graded between maximum size not over 1½-inch and not less than ¾-inch and minimum Size #4, crushed rock or washed gravel. For concrete encased conduit only, maximum aggregate size shall be ½-inch.
3. Fine Aggregate: Clean, natural washed sand of hard and durable particles varying from fine to particles passing ¾-inch screen, of which at least 12% shall pass fifty mesh screens.

B. Water: Clean and free from deleterious quantities of acids, alkalis, salts, or organic materials.

C. Reinforcement

1. Bars: Intermediate Grade Steel conforming to ASTM A615/A615M grade 60, with pattern deformations.
2. Welded Wire Fabric: ASTM A185/A185M.
3. Bending: Conform to Requirements of ACI 318.

D. Form Material: For exposed work, use PS 1-66 "B-B Concrete Form" plywood forms, or equal. Elsewhere, forms may be plywood, metal, or 1-inch by 6-inch boards. Forms for round lighting pole bases shall be sono-tube.

2.12 WIREWAY

A. General:

Unobstructed lay in type, metal wireway, fittings and connectors UL listed for use as wireway and auxiliary gutter. Length, elbows and "T-S" as shown on Drawings. Minimum cross-section size 4-inches by 4-inches, but not less than shown on the Drawings. Suitable for mounting in any position orientation.

B. Construction:

1. Minimum metal gauge shall not be less than 14 gages.
2. Cover shall be hinged entire length of cover. Cover shall be held in the closed position with bolts and nuts.
3. Provide spring nuts on all hardware fastener penetrations into the interior of the wireway to protect against wire insulation damage.
4. The inside of 90-degree corners in the wireway shall be a 45-degree bevel.

5. Grounding continuity between wireway sections and fittings shall be continuous the entire length of the wireway.
- C. Finish:
1. Indoor non-raintight, rust inhibitor phosphatizing base coating and baked enamel finish, Manufacturer's standard color.
 2. Raintight outdoor-galvanized metal, with corrosion resistant phosphate primer and baked enamel finish, Manufacturer's standard color, NEMA 3R construction.
 3. All hardware shall be plated to prevent corrosion.

PART 3 - EXECUTION

3.01 GROUNDING (ADDITIONAL REQUIREMENTS)

- A. Grounding shall be executed in accordance with all applicable Codes and Regulations, both of the State of California and Local authorities having jurisdiction.
- B. The neutral of each transformer shall be grounded by individual separate ground conductors in individual conduits as follows:
 1. Conductor and conduit shall be grounded to building main ground bus.
 2. Conductor and conduit shall be grounded to nearest available effectively grounded building structural steel member or grounded metal cold water pipe.
- C. The transformer neutral ground conductors for secondary side of the transformers shall be copper and shall be sized according to the following table:

<u>Secondary Total Equivalent Size Copper</u>	<u>Neutral Ground Wire Size Copper</u>
#2 or smaller	#6-1-inch conduit
1 or 1/0	#4-1-inch conduit
2/0 or 3/0	#2-1¼-inch conduit
4/0 thru 350 MCM	#1-1¼-inch conduit
Over 350 MCM thru 600 MCM	2/0-1½-inch conduit
Over 600 MCM thru 1100 MCM	3/0-1½-inch conduit
Over 1100 MCM	4/0-2-inch conduit
- D. Each pullbox or any other enclosure in which several ground wires are terminated shall be equipped with a ground bus secured to the interior of the enclosure. The bus shall have a separate lug for each ground conductor. No more than one conductor shall be installed per lug.
- E. The maximum resistance to ground shall not exceed 5 ohms.

3.02 OUTLET AND JUNCTION BOXES

- A. General:
 1. Accurately place boxes and securely fastens to structural members. Where outlets are shown at same location but at different mounting heights, install outlets in one vertical line. Where outlets are shown at same location and mounting height, mount outlets as close together in a horizontal row as possible. Where the outlet boxes for switches and receptacles are shown at the same location and mounting height, mount in common outlet box with barriers between devices. Provide single piece multi-gang cover plate for

close mounted outlet boxes. Where switches are shown on wall adjacent to hinge side of doors, box shall be installed to clear door when door is fully opened.

2. Flush mounted boxes shall be attached to not less than two parallel studs or structure members by means of metal supports. The supports shall span between and attach to the structure members.
 3. Boxes above accessible ceilings shall be attached to structural members. Where boxes are suspended, they shall be supported independently of conduit system by means of hanger rods and/or preformed steel channels. Boxes shall be supported independently of all piping, ductwork, equipment, ceiling hanger wires and suspended ceiling grid system.
 4. Surface mounted outlets shall be attached to concrete or masonry walls by means of expansion shields.
 5. Floor boxes shall be installed level with finish floor and within adjustable limits of floor ring. Where outlets are shown at same or adjacent location, use multi-gang boxes.
 - a. Provide cut-outs in the sub-floor assembly, to accept the recess depth of each electrical floor box. Provide added "fire-proof" applications on the bottom of each floor box location extending through the sub-floor. The "fire-proof" application shall be equal to the floor fire-assembly withstand rating.
 - b. Poke-thru floor outlets, core drill floor for installation of poke-thru. Install "split-box" in the ceiling space of the floor below. If the ceiling space of the floor below is not accessible ceiling type (lift-out), then provide 12-inches round removable fire-rated stainless steel access panel and trim-ring in the finish ceiling for hand-access to poke-thru "split-box" above the ceiling.
 6. Outlet Box Horizontal and Vertical Separation: Outlet boxes and device outlet rings installed flush in walls shall be horizontally and vertically separated by not less than 24-inches (edge of box to edge of box) from device outlet boxes and rings in common wall surfaces located on the opposite (back) side of the same wall.
 - a. Where the separation cannot be maintained, provide a solid backing behind and completely enclosing each outlet box.
 - b. The backing shall extend the width of the wall cavity (i.e., between "studs" or masonry cells) behind the box and 12-inches above and below the outlet box centerline, completely enclosing the outlet box.
 - c. The backing shall consist of the following:
 - 1) $\frac{5}{8}$ -inch thick gypsum board anchored in place for "stud" wall construction.
 - 2) Solid "mortar" to completely fill the outlet box "cell" behind the box in masonry construction.
 7. Provide metal outlet box for each device. Install devices in metal outlet boxes. Typical for all wiring devices including, switches, receptacles, line voltage devices, and low voltage/signal system devices.
- B. Fire Wrap:
1. In fire rated walls and ceilings provide fire rated "box-wrap" around the outside of each outlet box placed in fire rated wall or ceiling. Install the fire wrap on exterior of box

inside the wall or ceiling, to maintain the fire rating of wall or ceiling with the installed outlet boxes.

3.03 SWITCHES AND RECEPTACLES-DEVICES

A. General

1. Provide outlet boxes for all devices, switches, receptacles, both line-voltage and low-voltage.
2. Devices installed in wireways shall be installed flush in wireway assembly.
3. Install and screw attach devices into outlet boxes and wireways.
4. Provide ground circuit connections to all devices.
5. Provide branch circuit connections to all devices.
6. Provide testing and commissioning for proper operation and phase/ground connectors.
 - a. Test each GFCI devices after installation and circuit connection is complete.
 - b. Test all devices for correct polarity and proper electrical energization.
7. Install and adjust all coverplates to be flush and level, with correct device identification.
8. Were one or more device occurring at the proximity with other similar devices, all of the devices shall be "granged" under one common coverplate as follows:
 - a. Duplex convenience receptacles with other proximity (within 18-inches) duplex convenience receptacles.
 - b. Lighting control switches not exceeding 20-amp switch rating with other proximity (within 18-inches) similar switches.

B. Line-voltage Plug-In Type Receptacle Installation Orientation:

1. The "ground-pin" shall face "up" at the receptacle top location (double duplex) 4-plex, individual and vertically mounted individual duplex receptacles.
2. The "neutral-blade" shall face "up" at the receptacle top location on horizontally mounted duplex receptacles.

3.04 CONCRETE WORK

A. Form:

1. Space forms properly with spreaders and securely tie together. Do not use twisted wire form ties. Keep forms wet to prevent joints from opening up before concrete is placed. Replace improper construction as directed. Do not use wood inside forms.
2. Build in and set all anchors, dowels, bolts, sleeves, iron frames, expansion joints and other materials required for the Electrical Work. Place all items carefully, true, straight, plumb, and even.
3. Carefully remove all exposed forms. Cut nails and tie wires below face of concrete and fill all holes. Rubbish will not be allowed to remain in, under, or around concrete.

- #### **B. Mixing:** Use batch machine mixer of approved type. After ingredients are in mixer, mix for at least 1½-minutes.

- C. Transit Mixing: In lieu of mixing at site, transit mixing may be used if rate of delivery, haul time, mixing time, and hopper capacity is such that concrete delivered will be placed in forms within 90-minutes from time of introduction of cement and water to mixer.
- D. Placing of Concrete
 1. Before placing concrete, remove wood, rubbish, vegetable matter and loose material from inside forms. Thoroughly wet down wood forms to close joints.
 2. Clean reinforcement; remove paint, loose rust, scale and foreign material. Bars with bends not called for will be rejected. Hold securely in place to prevent displacement. Lap bar splices 24-diameters, min; lap fabric one-mesh minimum. Tie intersections, corners, splices with 16-gallon annealed wire, or as otherwise called for.
 3. Place concrete immediately after mixing. Do not use concrete that has begun to set; no tempering will be allowed. If chuting is used, avoid segregation. In placing new concrete against existing concrete, use bonding agent per Manufacturer's directions.
 4. Give careful and thorough attention to curing of concrete. Keep concrete and forms wet for a minimum of 10-days, after placing concrete.
- E. Concrete Finish
 1. Finish of Exposed Concrete: Horizontal surfaces, steel troweled monolithic finish; vertical surfaces, smooth and free of fins, holes, projection, etc.
 2. Exposed lighting pole bases shall be filled, and sack finished to a smooth finish.

3.05 WIREWAY INSTALLATION

Wireway hangers shall provide clamp type, hanger rod type, direct bolted bracket type from ceiling or walls as indicated on the Drawings and required for field installation locations. Supports shall be installed a minimum of 5-feet on center.

END OF SECTION 26 05 01
021821/212276

SECTION 26 05 30
CONDUIT AND WIRE

PART 1 - GENERAL

1.01 SCOPE

- A. Work Included: All labor, materials, appliances, tools, equipment, facilities, transportation, and services necessary for and incidental to performing all operations in connection with furnishing, delivery and installation of the work of this Section, complete as shown on the Drawings and/or specified herein. Work includes, but is not necessarily limited to the following:
 - 1. Examine all other Sections for work related to those other Sections and required to be included as work under this Section.
 - 2. General Provisions and Requirements for electrical work.

1.02 SUBMITTALS (ADDITIONAL REQUIREMENTS)

- A. Submit product data sheets for all wire, supports, conduit, fittings and splicing materials.
- B. Submit material list for all conduit and conduit fittings.
- C. Submit details and structural engineering calculations for conduit support systems.

PART 2 - PRODUCTS

2.01 CONDUIT

- A. General
 - 1. The interior surfaces of conduits and fittings shall be continuous and smooth, with a constant interior diameter. Conduits and conduit fittings shall provide conductor raceways of fully enclosed circular cross section. The interior surfaces of conduits and fittings shall be without ridges, burrs irregularities or obstructions. Conduits and fittings of the same type shall be of the same uniform weight and thickness.
 - 2. Type of conduit, type of conduit fittings and conduit supports shall be suitable for the conditions of use and the conditions of location of installation, based on the Manufacturer's recommendations and based on applicable Codes.
 - 3. All fittings for metal conduit shall be suitable for use as a grounding means, pursuant to the applicable Code Requirements. All metal conduit and metal conduit fittings shall provide 3 second duration ground fault current carrying ratings, when installed and connected to the respective conduit, as follows:
 - a. RMC and EMT conduit fittings.
 - 1) 0.5 inch through 1.5 inch conduit/fitting size - 10,000 amp RMS.
 - 2) 2.0 inch and larger conduit/fitting size - 20,000 amp RMS.
 - b. FMC and LTFMC Conduit Fittings
 - 1) 0.5 inch through 1.25-inch conduit/fitting size-1,000 amp RMS (without external bonding jumper).

- 2) 1.5 inch through 4.0-inch fitting size-10,000 amp RMS with bonding jumper.
4. Protective corrosion resistant finish for metal conduit fabricated from steel and metal conduit fittings fabricated from steel, shall be as follows:
 - a. Clean all metal surfaces (including metal threads) with acid bath “pickle” prior to coating, to remove dirt, oil and prepare surfaces for galvanizing.
 - b. Hot-dip galvanized zinc coating on all interior and exterior steel surfaces. Minimum finish zinc coating thickness shall not be less than 0.002 inches.
 - c. Threads shall be hot-dip zinc coated after machine fabrication.
 - d. Exterior metal surfaces shall be finished with clear organic polymer topcoat layer, after galvanizing.
 - e. The inner metal surfaces of conduit fittings shall be finished with a lubricating topcoat after galvanizing, to facilitate conductor pulling through the conduit/fitting.
5. Threads for metal conduit and metal conduit fittings shall be taper-pipe-thread, National Pipe Standards (NPS) and shall comply with ANSI-B1.20.1.
6. Metal conduit termination connector fittings shall be provided with a Manufacturer installed, insulating throat bushing inside the fitting. The bushing shall protect the wire conductor insulation from cutting, nicks and abrasion during conductor installation and electrical load “cycling” after installation is complete. The bushing shall comply with UL 94V-0 flammability.
7. Provide conduit bonding/grounding jumper from metal enclosures with “concentric ring” knockouts, to positively ground/bond each respective conduit(s) to the metal enclosure.
8. Metal conduit fittings connecting to PVC coated metal conduit shall be PVC coated to match the conduit.
9. The conduit and fittings shall be watertight and airtight without cracks and pinholes.
- B. Rigid Metal Conduit (RMC)
 1. Rigid metal, round tubing, machine threaded at both ends.
 - a. The conduit and conduit fittings shall comply with the Requirements for an equipment grounding conductor, pursuant to applicable Codes.
 2. RMC raceway types shall be as follows:
 - a. Rigid Galvanized Steel conduit (RGS), minimum yield strength shall be 35,000 PSI. Shall comply with NEMA standard 5-19 (latest revision); ANSI C80.1 and ANSI-C80.4 (latest revision); UL 514-B and UL 6 (latest revisions); National Pipe Standard Specification (latest revision).
 - b. Intermediate steel conduit (IMC). Shall comply with NEMA Standard 5-19 (latest revision) ANSI-C80.6 (latest revision); UL 2142 (latest revision).
 3. RMC fittings:
 - a. Fittings shall be compatible with RGS and IMC.
 - b. Fittings shall be rated “liquid tight”.
 - c. Fittings imbedded in concrete shall be rated “liquid tight” and “concrete tight”.
 - d. Connectors and couplings for terminating, connecting, and coupling to RMC conduit shall be threaded metal.

- e. Fittings shall comply with ANSI C80.4 and ANSI C33-84 (latest revision); NEMA FB1 (latest revision); UL 514 (latest revision).
 - f. Conduit seal fittings:
 - 1) Conduit seals shall prevent the passage of gasses, liquids and vapors past the location of the seal installation in the conduit.
 - 2) Conduit seals shall be suitable for installation in both vertical and horizontal conduit locations.
 - 3) Conduit seals shall be visible and accessible for inspection after installation is complete.
 - 4) Conduit seals shall be rated for the following locations:
 - a) Wet locations
 - b) Classified hazardous location materials NEC Class 1 Division 1.
 - c) Temperature ranges from 0 degrees centigrade through 90 degrees centigrade.
 - 5) Conduit seals, sealing compound and sealing compound dam shall be the products of the same Manufacturer.
4. RMC fittings as manufactured by:
- a. For threaded enclosure, termination connection.
 - 1) Thomas & Betts - 106 Series bonding locknut, 5302 Series sealing ring with stainless steel retainer.
 - b. For non-threaded enclosure, termination connector.
 - 1) Thomas & Betts - 370 Series watertight threaded sealing hub, 106 Series threaded bonding locknut, Sta-Con Series enclosure bonding jumper and 3870 Series threaded ground bushing.
 - 2) Emerson-OZ/Gedney-CHMT/CHT watertight threaded hub with bonding locknut and GH50G Series enclosure bonding jumper.
 - c. For RMC to RMC conduit-to-conduit coupling
 - 1) Thomas & Betts/Erickson - 674 (threaded) Series
 - 2) Emerson-OZ/Gedney Type TPC (threaded) Series
 - 3) Threaded RMC conduit couplings, product of the same Manufacturer as the RMC conduit.
 - d. For RMC Conduit Seals
 - 1) Emerson-OZ/Gedney-EYA and EYAM (threaded) Series
 - 2) Appleton-EYF and EYM (threaded) Series
- C. Electrical Metallic Tubing (EMT)
- 1. Rigid metal round tubing, "thin wall" steel construction, with non-threaded ends.
 - a. The conduit and conduit fittings shall comply with the Requirements for an equipment grounding conductor pursuant to applicable Codes.
 - b. The conduit shall be watertight and airtight without cracks and pinholes.
 - 2. EMT shall be allowed for conduit size ranges from 0.5-inch through 4.0-inches.

3. Comply with ANSI C80.3, C80.4, and ANSI C33.98 (latest revisions); UL 594 and UL 797 (latest revisions); CEC Section 12500 (latest revision).
 4. EMT fittings:
 - a. Connectors and couplings for terminating, connecting and coupling to EMT conduit shall be non-threaded steel fabrication.
 - b. EMT termination connector fittings shall be as follows:
 - 1) Set screw type “concrete tight” when installed in dry interior locations.
 - 2) Compression types “raintight” and “concrete tight” when installed in wet or damp locations, outdoors and in concrete or masonry construction.
 - c. Fittings shall comply with ANSI C33.84 (latest revision); UL 514 (latest revision); NEMA FB-1.
 5. EMT fittings as manufactured by:
 - a. For threaded and non-threaded enclosure, termination connector
 - 1) Thomas & Betts-TC721A (set screw type) Series (with locknuts).
 - 2) Emerson-OZ/Gedney-TC500I (set screw type) Series (with locknuts).
 - 3) Thomas & Betts-5123 (compression type) Series (with two locknuts).
 - 4) Emerson-OZ/Gedney-TC600I (compression type) Series (with locknut).
 - 5) Thomas & Betts-4240 (compression type) Series (90-degree angle with locknut).
 - 6) Emerson-OZ/Gedney-TWL (compression type) Series (90-degree angle with locknut).
 - b. For EMT to EMT conduit-to-conduit coupling:
 - 1) Thomas & Betts-TK121A (set screw type) Series (with locknut).
 - 2) Emerson-OZ/Gedney-5000 (set screw type) Series (with locknut).
 - 3) Thomas & Betts-5120 (compression type) Series.
 - 4) Emerson-OZ/Gedney-TC600 (compression type) Series.
 - c. For EMT to RMC conduit to conduit combination coupling:
 - 1) Thomas & Betts-HT221 (set screw type) Series.
 - 2) Emerson-OZ/Gedney-ESR (set screw type) Series.
 - 3) Thomas & Betts-530 (compression type) Series.
 - 4) Emerson-OZ/Gedney-ETR (compression type) Series.
- D. Flexible Metal Conduit (FMC)
1. Round flexible conduit fabricated from a single continuous steel strip. The steel shall be factory formed into continuous interlocking convolutions to form a complete lock between steel strips and provide raceway flexibility.
 2. Metal to metal grounding contact shall be maintained throughout the length of the FMC conduit.
 3. FMC shall be allowed for conduit size ranges from 0.5 inch through 4.0-inches.
 4. FMC shall comply with ANSI-C.33.84 and ANSI C33.92; NEMA FB-1; CEC 12-1100.

5. FMC Fittings
 - a. FMC fittings shall be malleable iron construction or steel construction.
 - b. Fitting shall automatically cause the FMC raceway throat opening to be centered with respect to the fitting throat opening.
 - c. Straight and angled connector termination fittings shall be threaded on one end and shall include a threaded locknut, suitable for connection to threaded and unthreaded enclosures.
 - d. The attachment of the fittings to FMC shall be angled saddle type, to engage and interlock with the FMC spiral groove, and shall be unaffected by vibration. Direct bearing screw type fittings shall not be used.
 - e. Direct FMC conduit-to-FMC conduit coupling of FMC shall not be permitted.
 - f. Shall comply with ANSI C33.9, and ANSI C33.92 (latest revision); NEMA FB1 (latest revision); UL 514.
 6. FMC fittings as manufactured by:
 - a. Straight Termination Connectors 45 and 90 Degree Angle Connectors
 - 1) Thomas & Betts-3110 Series Thomas & Betts-3130 Series
 (with locknut) (with locknut)
 - b. FMC to EMT conduit combination coupling:
 - 1) Thomas & Betts 503TB Series.
- E. Liquid Tight Flexible Metal Conduit (LTFMC)
1. The metal conduit core of LTFMC shall comply with the same Requirements as FMC conduit, with the addition of a thermoplastic exterior flexible jacket over the metal core.
 2. The exterior jacket shall be positively locked to the metal core to prevent jacket “sleeving”.
 3. The LTFMC shall be rated for installation and operating service temperatures of between minus 20 degrees centigrade through plus 90 degrees centigrade.
 4. The LTFMC jacket shall be suitable for continuous exposure to sunlight, rainwater, water vapor, mineral oils and liquid solvents, without penetrating into the conduit and without deteriorating the jacket.
 5. LTFMC sizes from 0.5-inch through 1.25-inch shall include an additional internal ground conductor, fabricated by the Manufacturer, as an integral part of the conduit core.
 6. Direct LTFMC conduit-to-LTFMC conduit coupling of LTFMC shall not be permitted.
 7. LTFMC shall be allowed for conduit size ranges from 0.5-inch through 4.0-inches.
 8. In addition to the Requirements for FMC conduit, LTFMC shall also comply with ANSI C-33.84 (latest revision); NEMA-FB1 (latest revision); CEC 12-1400 (latest revision).
 9. LTFMC fittings
 - a. Fittings shall include an external mechanical ground/bond wire connector.
 - b. The attachment of the fitting to LTFMC shall be threaded compression type onto the conduit core with locknut and liquid tight jacket compression seal. The fitting shall automatically prevent “sleeving” of the jacket.

- c. Straight and angled termination connector fittings shall be threaded on one end and shall include locknut suitable for connection to threaded and unthreaded enclosures.
10. LTFMC fittings as manufactured by:
- a. Termination connector fittings:

<u>Straight</u>	<u>45 & 90 Degree Angle Connectors</u>
1) Thomas & Betts-5331 GR Series.	Thomas & Betts-5341GR & 5351GR Series.
2) Appleton-STB Series; STN-L with preformed Series for use "knockouts".	Appleton-STB-L Series; STN-L Series for use with preformed "knockouts".
3) Emerson- OZ/Gedney-4QSeries.	Emerson-OZ/Gedney-4Q Series
 - b. LTFMC to RMC conduit to conduit combination coupling fittings:
 - 1) Thomas & Betts-5271 GR Series.
 - 2) Emerson-OZ/Gedney-4Q Series
- F. Rigid Non-Metallic Conduit (RNMC)
- 1. General
 - a. Conduit and fittings shall be 90-degree centigrade conductor rated. Fabricated from homogeneous material, free from visible cracks, holes or foreign inclusions, with integral "end-bell". The conduit and conduit fittings shall be watertight and airtight.
 - b. Conduit, conduit fittings and conduit fitting assembly "solvent cement" shall all be the product of the same Manufacturer. Conduit fittings shall be solvent cement welded watertight.
 - c. Conduit and fittings shall be identified with legible markings showing ratings, size and Manufacturers name.
 - d. RNMC and fitting shall be corrosion resistant, watertight.
 - e. Conduit shall be suitable for conductor operating temperatures from minus 20 degrees centigrade to 90 degrees centigrade.
 - f. RNMC shall comply with NEMA TC-2 (PVC 40 conduit, latest revision) NEMA TC-6 (EB conduit latest revision) and NEMA TC-3 (fittings, latest revision); UL 514 and UL 651 (latest revision).
 - 2. Polyvinyl Chloride (PVC)-RNMC
 - a. PVC-Schedule 40 heavy wall construction.
 - b. PVC-Schedule 80 extra heavy wall construction.
 - c. PVC-Type EB.
 - 3. RNMC fittings connecting to metallic raceways shall be provided with a ground/bond jumper connection.
- G. Combi-Duct
- 1. Rigid nonmetallic conduit combining a continuous linear outer raceway (duct) with factory installed (inside the outer duct) multiple, segregated inner raceway (ducts). Rigid, Schedule 40 PVC construction. Shall be modular lengths of 20-feet for each duct segment.

2. The conduit shall be suitable for use with signal/ telecommunications, fiber optic, telephone and computer/data circuits, operating at 100 volts or less, UL listed and labeled.
3. Outer Duct, outer enclosing Schedule-40 PVC duct size. The outer enclosing duct shall be 4.2-inches inside nominal duct diameter and 4.5-inches outer duct nominal diameter.
4. Inner-ducts (Contained inside the enclosing outer duct), non-metallic SDR-19 or Type-C /CAO-8546:

Triple Combi-Duct

- a. Quantity of three continuous round rigid inner linear ducts, nominal size inside diameter 1.5-inch for each inner duct.

Quad Combi-Duct

- b. Quantity of four continuous round rigid inner linear ducts, nominal size inside diameter 1.19-inch for each inner duct.

5. Manufacturer's standard bends and offsets, minimum 72-inches radius.
6. Combi-duct and combi-duct fittings shall be airtight and watertight. Approved for direct burial in earth and approved for encasement in concrete.
7. As manufactured by Carlon # Multi-Guard/Multi-Cell Series; American Pipe and Plastic (AMTEL) #Multi-Bore Series; or equal.

H. Expansion Joint, Deflection Joint and Seismic Joint Conduit Fittings

1. Expansion Conduit Fitting - Fitting shall provide for a minimum of 2-inches straight line movement between two connecting conduits in each direction (total 4-inches conduit expansion and contraction) parallel to the respective conduit lengths. Fitting shall be watertight.
2. Deflection Conduit Fitting - Fitting shall provide for a minimum of 30 degrees angular deflection movement ("Shear" deflection) between two connecting conduits, in any direction perpendicular to the length of the respective conduits. Fitting shall be watertight.
3. Combination Expansion/Deflection Conduit Fitting - Fitting shall provide the combined "expansion" and "deflection" movement capacity between two connecting conduits as described for separate "expansion" and "Deflection" conduit fittings. Fitting shall be approved for installation concealed in both masonry/concrete construction and exposed non-masonry/concrete construction. Fitting shall be watertight.
4. Fittings shall comply with UL.
5. Fittings as manufactured by:
 - a. Conduit expansion fittings exposed, or concealed locations as manufactured by:
 - 1) Emerson-OZ/Gedney – AXB-8 Series for RMC conduit.
 - 2) Emerson-OZ/Gedney - TX Series for EMT conduit.
 - 3) Appleton – AXB or XJ8 Series for RMC conduit and EMT conduits. Provide RMC to EMT combination conduit coupling fittings for each end of the expansion fitting.

- b. Combination expansion/deflection conduit fittings exposed, or concealed conduit locations as manufactured by:
 - 1) Emerson-OZ/Gedney - AXDX Series for RMC conduit.
 - 2) Emerson-OZ/Gedney - AXDX Series for EMT conduit.
 - 3) Appleton-DX Series for RMC conduit.
 - 4) Provide RMC to EMT combination conduit coupling fittings for each end of the expansion/deflection fitting.
 - c. Conduit expansion/deflection fittings for FMC and LTFMC conduit.
 - 1) Provide a minimum of 12-inches of “slack” LTFMC in each FMC or LTFMC conduit at building and structure seismic or expansion joint conduit crossings.
 - 2) Note: Each FMC “slack” expansion/deflection location, shall be considered as not less than a 90-degree conduit bend location, for compliance with the maximum quantity of conduit bends allowed in a raceway.
6. Conduit fitting bonding jumper:
- a. The grounding/bonding path of metal conduit shall be maintained by the fitting.
 - b. Provide a bonding jumper at each expansion, deflection and combination expansion deflection conduit fitting.
 - c. The jumper shall be a bare flexible copper “braid”. The copper braid electrical current carrying capacity shall be equal to the metal conduit.
 - d. Provide a factory terminated ground clamp on each end of the braid with adjusting steel conduit grounding clamps and connect to each respective conduit end.
 - e. The jumper braid length shall be 8-inches longer than the respective conduit fitting.
 - f. Bonding jumper for FMC and EMT fittings as manufactured by:
 - 1) Emerson-OZ/Gedney – BJ and BJE Series
 - 2) Appleton – BJ/XJ Series
- I. Conduit Bodies Conduit Fitting
- 1. Conduit bodies shall provide conductor access with a removable conduit body cover and wiring area enclosed in metal housing. The conduit body shall facilitate pulling conductors.
 - 2. In-line form “C” conduit bodies shall be prohibited.
 - 3. The interior space “length” of 90 degree “elbow” conduit bodies shall not be less than six times the diameter size of the largest conduit connecting to the conduit body.
 - 4. Conduit body covers shall be removable, gasketed; watertight “domed” metal covers “Mogul-Type” with threaded screw attachment to the conduit body.
 - 5. Lubricated, reusable, wire roller guards inside the conduit body shall protect wire from insulation damage during wire “pulling”.
 - 6. Conduit body fittings shall comply with UL 514.
 - 7. Conduit bodies as manufactured by:
 - a. For RMC Conduit
 - 1) Hubbell/Killark – LB/Mogul (90-degree elbow) Series – threaded body.

- 2) Emerson-OZ/Gedney - LB 6X/Mogul (90-degree elbow) Series - threaded body.
 - 3) Appleton – NEC6X-LB/Mogul (90-degree elbow) Series - threaded body.
- b. For EMT Conduit
- 1) Same as for RMC conduit. Provide EMT to RMC conduit combination coupling fitting for each outlet body connection.

2.02 PVC COATING

- A. PVC coatings shall be provided as described for specified metal products.
- B. PVC coating shall be factory applied, to comply with NEMA-RN1 and 5-19.
- C. The adhesion of the PVC coating to the coated metal shall exceed the strength of the coating itself, based on 0.5-inch “strip-pull” test.
- D. Uniform coating thickness shall be continuous without “breaks” or “pinholes” and shall not be less than the following:
 1. Exterior metal surfaces, 40-millimeter coating thickness.
 2. Interior metal surfaces, 10-millimeter PVC or urethane coating thickness (i.e. interior of conduits, interior of conduit fittings etc.).

2.03 CONDUIT SUPPORTS

- A. General
 1. Conduit Supports, hangers and fasteners for metal conduit shall be steel, hot dip zinc galvanized.
 2. Conduit supports, hangers and fasteners for PVC coated conduit shall be PVC coated to match the conduit PVC coating.
 3. Threaded hardware shall be continuous, free running threads.
 4. Conduit support systems, including support channels, pipe clamps, braces, anchors, hardware, fasteners, shall be sized to support the full capacity circuit conductors’ weight, plus the installed conduit weight, plus the conduit fitting weight and support hardware weight, plus a 300% additional weight capacity safety factor.
 5. Provide lock washer at each “bolted”/threaded connection.
 6. Conduit supports, fasteners, channels, braces, hardware, anchors, pipe clamps, and hangers as manufactured by Unistrut or Kindorf.
 7. Supports shall be free of “BURRS” and sharp edges.
 8. Metal supports cut in the field shall be zinc galvanized after cutting to prevent rust.
- B. Conduit Hangers
 1. Threaded steel hanger rods.
 - a. Hanger rods smaller than 0.375-inches in diameter shall not be used for support of individual conduits.
 - b. Hanger rods smaller than 0.5-inches in diameter shall not be used for support of multiple conduits.
 2. Conduit hanger wires shall be not less than 12-gauge steel.

3. Conduit hangers shall attach to structure fasteners with steel “Clevis” or “Swing” hangers and shall provide a minimum of 45 degrees of angular movement in any direction at the point of the conduit hanger attachment to the structure fasteners.
 4. Conduits individually suspended by conduit hangers shall fasten to the respective hangers with “Clevis” type pipe hangers. The pipe hangers shall be steel, adjustable to fit conduit size and shall completely enclose the conduit circumference.
- C. Conduit Support Channels
1. “C” channels shall be factory preformed with a minimum 12-gauge thickness metal. The channel shall be factory “punched” with regularly spaced slotted holes for fastener attachments along the length of the channel.
 2. The “C” channel shall not deflect more than 0.1 inch between channel supports at maximum installed design load, including required safety factor.
 3. Channels shall comply with ANSI-1008 (latest revision) and ASTM-A569 latest revision).
 4. Channels shall provide “turned lips” at longitudinal edges to hold (lock-in) fasteners.
 5. Conduit support channels suspended from conduit hangers shall attach to conduit hangers with treaded connections. Provide a minimum of two hangers (trapeze style) connected to each channel.
 6. Non-suspended conduit support channels shall connect to structure fasteners with threaded connectors.
- D. Fasteners, Seismic Earthquake Rated
1. Channel fasteners:
 - a. Channel fasteners shall “prelocate” and lock into the channel “turned lips” and channel “walls”.
 - b. A separate metal strap shall “tie” each conduit to each channel with conduit channel fasteners.
 2. Structure fasteners:
 - a. Structure fasteners for wall and floor mounted conduit attachments shall attach to existing masonry and concrete structures with structure fasteners using drilled, mechanical, expansion shield anchors.
 - b. Structure fasteners for wall and floor mounted conduit attachments shall attach to new masonry and concrete structures with structure fasteners using steel threaded inserts precast into the structures.
 - c. Structure fasteners shall center the support load above or below the beam flanges and reduce torsion-rotation forces exerted on the structural beam. Attach to steel structural members with “swing-beam clamps”, with set-locking screw structure fasteners.
 - 1) Beam clamps shall include integral safety rod, strap or “J”-hook to secure the attachment clamp to the beam flanges on both sides of the beam, with integral hanger rod attachment.
 - 2) Or double-ended beam clamp to secure the attachment clamp to the beam flanges on both sides of the beam, with integral hanger rod attachment.

- d. Structure fasteners for wall and floor mounted conduit attachments shall attach to wood structural members with flush “through-bolted” wood beam/wood framing stud structure fasteners.
 - e. Structure fasteners for wall mounted conduit attachments shall attach to steel framing studs and steel structural elements with spot welded steel structure fasteners or drilled and bolted structure fasteners.
- E. Brace Connectors
- 1. Provide lateral brace connectors to resist horizontal, lateral and vertical movement of suspended conduits during seismic earthquakes.
 - 2. The braces shall connect from each conduit support, attach as close to the conduit as possible, and attach to fixed rigid, non-suspended building “main” structural elements with fixed anchoring.
 - 3. Brace attachment connectors and fasteners shall be rigid preformed steel channels or flexible #10 gauge steel hanger wire.
 - 4. Connect and attach the brace connectors to fixed structural elements in the same manner as conduit support hangers. The connection of braces to structural elements shall be independent of the conduit support hanger structure fasteners.

2.04 ELECTRICAL POWER WIRE AND CABLE

A. General

- 1. All wire and cable shall be single-conductor, annealed copper, insulated 600 volts, #12AWG minimum unless specifically noted otherwise on the Drawings.
- 2. Conductors #10AWG and smaller shall be solid. Conductors #8AWG and larger shall be stranded.
- 3. Insulation of conductor connected to circuit protection devices required to be "100%" rated, shall be 90-degree centigrade rated insulation.
- 4. Insulation of conductors installed outdoors, on grade or underground, insulation shall be rated for wet locations.
- 5. Insulation of conductors installed outdoors, installed exposed to the sun, installed in exposed conduits, insulation shall be rated for high-temperature 90 degrees centigrade.
- 6. Insulation of branch circuit conducts installed in light fixtures; insulation shall be rated for 90 degrees centigrade.
- 7. Conductor exposed to oil, insulation and jacket shall be oil resistant, complying with “Oil Resistant-1” and “Oil Resistant-2” UL 83.

B. Conductor Insulation

- 1. 600 Volt AC and/or DC insulated conductors installed entirely inside conduits, or enclosed inside wireways, or enclosed inside raceways, insulation shall be rated as follows.
- 2. Indoor above Grade locations either concealed or exposed.
 - a. Dual rated THHN and THWN
 - b. Individually rated THHN-2
 - c. Individually rated THWN-2

- d. XHHW-2
 - 3. Outdoor above Grade either concealed or exposed.
 - a. XHHW-2
 - b. THWN-2
 - c. THW-2
 - 4. Outdoor below Grade or outdoor on Grade.
 - a. XHHW-2
 - b. THWN-2
 - c. THW-2
 - 5. All other enclosed raceway locations not described above.
 - a. XHHW-2
 - b. THWN-2
 - c. THW-2
 - 6. Health Care facilities all circuits insulation shall be XHHW-2, rated Hospital-Grade.
 - 7. 600 Volt AC and/or DC insulated conductors installed in open cable tray or open wireway or exposed insulation also shall be rated for exposed install locations.
- C. Insulation Color Coding and Identification
- 1. The following color code for branch circuits:
 - a. Neutral . . . White (Tape feeder neutrals with white tape near connections)
 - b. Normal Power:
 - 120/208 Volt
 - Ground Green
 - Phase A Black
 - Phase B Red
 - Phase C Blue
 - c. Isolated ground insulation shall be green with a longitudinal yellow stripe.
 - d. Emergency power same insulation color as normal power except as follows:
 - 120/208 Volt
 - Provide a continuous stripe on each conductor insulation, orange or yellow, except ground.
 - 2. When individual neutral conductors are shown for each branch circuit, the color code for the neutral conductors shall be as follows:
 - a. 120/208 volt; Phase A - White with Black stripe; Phase B - White with Red stripe; Phase C - White with Blue stripe.
 - 3. Feeders identified as to phase or leg in each, switchboard, switchgear, panelboard, and junction location with printed identifying tape.
 - 4. Fire alarm conductors: Use 600-volt, type THHN-2/THWN-2 conductors and color-coded per Equipment Manufacturer's recommendations and approved and listed for use on fire alarm systems by the State Fire Marshal.

5. Color coding for mechanical and plumbing control wiring shall be an agreed upon color code between the Mechanical/Plumbing Contractor and the Electrical Contractor, and color code shall be submitted to the District's Representative in writing for approval prior to installation.
- D. Panel feeders, copper or aluminum:
1. Wire size shown on the Drawings is for copper conductors, unless specifically indicated otherwise.

2.05 CABLE RACKS

- A. Cable racks, installed on the vertical walls of the structure, including hooks and porcelain insulator cable cradles, shall be sufficient to accommodate the cables and splices.
- B. Vertical racks shall be installed on all walls of the structure a minimum of 24-inches on center within 6-inches of floor and top of wall. A rack shall be installed within 18-inches of each corner of each wall. Additional racks spaced equally on each wall shall be installed; spacing between vertical wall racks shall not exceed 24-inches.
 1. Wall racks shall be slotted to accept removable hooks and lock hooks into place.
 2. Non-metallic, 50% (minimum) glass reinforced nylon or non-metallic material of the same characteristics.
 3. The installed cable racks, cable support hooks with arms and wall anchor bolts shall support the following minimum loads for each hook/arm, with a 200% minimum safety factor. Based on multiple hook/arms located not less than 9-inches on center along the entire vertical length of the support rack:

	<u>Hook/Arm Length</u>	<u>Min. Weight Each Hook/Arm Supported</u>	<u>Max. Allowable Hook/Arm Deflection</u>
a.	8-inches	450 pounds	0.25-inch
b.	14-inches	350 pounds	0.37-inch
c.	20-inches	250 pounds	0.37-inch

(Based on load concentrated 1-inch from the end of each hook/arm.)

4. Racks shall be bolted to the precast and cast-in place structure walls, within 3-inches of each rack end and not less than 9-inches on center. Provide cast-in place or after-set drilled expansion concrete anchors.

PART 3 - EXECUTION

3.01 TRENCHING, FOOTINGS, SLEEVES

- A. Provide trenching, concrete encasement of conduits, backfilling, and compaction for the underground electrical work, in accordance with applicable Sections of this Specification.
- B. Provide footings for all post and/or pole-mounted lighting fixtures: concrete shall conform to the applicable Sections of this Specification.
- C. Sleeves
 1. Provide sleeves for raceways, conduit and wire/cables passing through the following construction elements:
 - a. Concrete and masonry foundations, floors, walls and slabs.

- b. Gypsum, Lath, and plaster walls and ceilings.
 - c. Building structures (i.e., foundations, walls, floors, ceilings, beams, and roofs) with a fire rating exceeding 20-minutes.
2. Sleeves shall extend 1.5-inch above and below floors, except under floor standing electrical equipment. Sleeves shall be flush with wall ceiling foundations and partitions exposed to public view and extend approximately 0.5-inch past penetration in fire rated construction. Sleeves shall be installed at exact penetration locations and angles to accommodate wire/cable, raceway and conduit routings.
 3. Joists, girders, beams, columns or reinforcing steel shall not be cut or weakened. Where construction necessitates the routing of conduit or raceways through structural members, framing or footings, written permission to make such installation shall first be obtained from the District's Representative. Such permission will not be granted, however, if any other method of installation is possible.
 4. The layout and design of raceways and conduits located in or routed through masonry or reinforced beams or the District's Representative shall review walls before any work is performed. All sleeving shall be accomplished according to the instructions of the District's Representative and shall be accepted before any concrete is poured.
 5. Sleeves, raceways and conduit shall be located to clear steel reinforcing bars in beams. Reinforcing bars in walls shall be offset to clear piping and sleeves.
 6. Provide a continuous clearance between the inside of a sleeve and exterior of wire/cables, conduits and raceways passing through the sleeve not less than the following:
 - a. 0.5-inch clearance except as required otherwise.
 - b. 1.0-inch clearance through outside walls below grade.
 - c. 3.0-inch clearance through seismic joints.
 7. Sleeves set in fire rated construction shall be caulked between sleeve and building structure, additionally sleeves shall be caulked between the sleeve and the wire/cables, conduits/raceways passing through the sleeve. The caulking shall be a fireproof sealant, equal to the fire rating and temperature being penetrated. Clearance between components inside of sleeve and exterior of components passing through sleeve and between components inside the sleeve shall comply with Fireproof Sealant Manufacturer's recommendations.
 8. Sleeve material:
 - a. In floor construction: Schedule 40 black steel pipe, with upper surface to be sealed watertight.
 - b. In concrete or masonry walls roofs or ceilings: Schedule 40 black steel pipe. When installed in roofs or outside walls, seal outer surface watertight.
 - c. In fire rated construction; 24-gauge galvanized iron or steel.
 - d. Sleeves through waterproof membranes: Cast iron or Schedule 40 steel with flashing clamp device and corrosion resistant clamping bolts. Caulk space between pipe and sleeve and surfaces between sleeve and conduits sealed watertight.

3.02 GROUNDING

- A. Grounding shall be executed in accordance with all applicable Codes and Regulations, both of the State and local authorities having jurisdiction.
- B. Where nonmetallic conduit is used in the distribution system, the Contractor shall install the proper sized copper ground wire in the conduit with the feeder for use as an equipment ground. The electrical metallic raceway system shall be grounded to this ground wire.
- C. The maximum ground/bond resistance to the grounding electrode shall not exceed 1ohms from any location in the electrical system. The maximum ground resistance of the grounding electrode to earth shall not exceed 5 ohms.
- D. Ground/Bond Conductors
 - 1. Provide an additional, dedicated, green insulation equipment ground/bond wire inside each conduit type and raceway as follows. Size the ground/bond conductors to comply with CEC/NEC Requirements. The metal conduit or raceway shall not be permitted to serve (function) as the only (exclusive) electrical ground return path:
 - a. All types of nonmetallic conduit and all types of non-metallic raceways including but not limited to: RNMC - Rigid Nonmetallic Conduit.
 - b. FMC – Flexible Metal Conduit.
 - c. LTFMC – Liquid Tight Flexible Metal Conduit.
 - d. Metal and non-metal raceways.
 - e. RMC – Rigid Metal Conduit.
 - f. EMT – Electrical Metal Tubing.
 - 2. The equipment ground/bond wire shall be continuous from the electrical circuit source point of origin to the electrical circuit end termination utilization point as follows:
 - a. Every conduit and raceway path containing any length of the above identified conduits or raceway.
 - b. Every conduit path and raceway path connected to any length of the above-identified conduits and raceways.
 - 3. The equipment ground/bond wire shall be sized as follows, but in no case smaller than indicated on the Drawings. Install equipment ground/bond wire in each conduit/raceway, with the respective phase conductors:

<u>Feeder, Subfeeders & Branch Circuit Protection</u>	<u>Min. Equip Ground Wire Size</u>
15 amp	#12
20 amp	#12
30 to 60 amp	#10
70 to 100 amp	#8
101 to 200 amp	#6
201 to 400 amp	#2
401 to 600 amp	#1
801 to 1000 amp	2/0
1001 to 1200 amp	3/0
1201 to 1600 amp	4/0
1601 to 2000 amp	250 MCM
2001 to 2500 amp	350 MCM

2501 to 4000 amp

500 MCM

4. Isolated grounds - Raceways containing branch circuit or feeder phase conductors connected to panelboards equipment, or receptacles with isolated grounds or isolated ground bus shall contain a dedicated insulated ground conductor connected to the isolated ground system only. The isolated ground conductor shall be continuous the length of the raceways and connected only to the isolated ground terminals in addition to and independent of the equipment bonding/ground conductor. The isolated ground conductor shall be sized as indicated above, for equipment ground/bond wire.
 5. Splices in ground/bond wires shall be permitted only at the following locations:
 - a. Ground buses with listed and approved ground lugs.
 - b. Where exothermic welded ground/bond wire splices are provided.
 6. Provide ground/bond wire jumpers for conduit fittings with ground lugs, expansion and deflection conduit fittings at conduit fittings connecting between metallic and non-metallic raceways and to bond metal enclosures to conduit fittings with ground lugs.
- E. Where conductors are run in parallel in multiple raceways, the grounding conductor shall be run in parallel. Each parallel equipment-grounding conductor shall be sized on the basis of the ampere rating of the overcurrent device protecting the circuit conductors in the raceway. When conductors are adjusted in size to compensate for voltage drop, grounding conductors, where required, shall be adjusted proportionately in size.
- F. Ground conductors for branch circuit wiring shall be attached at each outlet to the back of the box using drilled and tapped holes and washer head screws, 6-32 or larger.
- G. Each panelboard, switchboard, pull box or any other enclosure in which several ground wires are terminated shall be equipped with a ground bus secured to the interior of the enclosure. The bus shall have a separate lug for each ground conductor. No more than one conductor shall be installed per lug.

3.03 CONDUIT

- A. General
1. The sizes of the conduits for the various circuits shall be as indicated on the Drawings, but not less than the conduit size required by Code for the size and quantity of conductors to be installed in the conduit.
 2. Conduits shall be installed concealed from view. Install conduits concealed in walls, concealed below floors and concealed above ceilings, except as specifically noted otherwise.
 - a. Conduits shall not be installed in concrete floors.
 3. The following systems shall be considered as circuits 100 volts and less, all other circuits shall be considered to be over 100-volts (power circuits) unless specifically noted otherwise: Fire alarm, energy management control, telephone, public address, data, computer, television, intercom, intrusion alarm and nurse call.
 4. Conduits shall be provided complete with conduit bends, conduit fittings, outlet boxes, pullboxes, junction boxes, conduit anchors/supports, grounding/bonding for a complete and operating conductor/wire raceway system.

5. Metal and nonmetal conduits shall be provided mechanically continuous between termination connection points. Metal conduit shall be provided electrically continuous between termination connection points.
6. Individual conduit paths and home runs shown on the Drawings shall be maintained as separate individual conduits for each homerun and path.
7. Conduits, conduit fittings and installation work occurring in classified hazardous materials locations shall comply with applicable Code Class 1 Division 1 Requirements, unless specifically noted otherwise.
8. Transitions between conduits constructed of different materials and occurring in above grade locations shall be allowed only at outlet boxes, junction boxes, pull boxes and equipment enclosures unless specifically indicated otherwise. Provide outlet boxes and junction boxes.
9. Metal conduit terminating to nonmetal enclosures; terminating into metal enclosures with “concentric.ring” knockouts; terminating into metal enclosures with knockout reducing washers, including but not limited to equipment housings, outlet boxes, junction boxes, pull boxes, cable trenches, manholes, shall be provided with a ground/bonding lug integrated with the conduit termination conductor fitting construction, by the Fitting Manufacturer. The lug shall provide for connection of a grounding/bonding conductor (insulated or uninsulated). The grounding lug shall be located on the fitting, inside the termination enclosure.
10. The type of conduit, type of conduit fittings, and type of conduit supports, and method of conduit installation shall be suitable for the conditions of use and conditions of location of installation based on the Manufacturer’s recommendations; based on the applicable Codes and based on the Requirements of the Contract Documents.

B. RMC Installation Locations

RGS, IMC conduits and RGS, IMC fittings shall be installed in the following locations:

1. Embedded in floors, walls, ceilings, roofs, foundations, and footings constructed with concrete.
2. Embedded in walls and foundations constructed with brick and masonry.
3. Interior of buildings, within 9-feet of finish floor lines for exposed conduit locations.
4. Exterior of building for exposed conduit locations.
5. Damp or wet locations exposed or concealed locations.
6. Exposed on roofs.
7. In hazardous materials areas and locations; below hazardous materials areas and locations; above hazardous materials areas and locations.
8. Exposed on utility service poles, for pole risers less than 9-feet above finish grade.
9. RMC conduit and RMC fittings may be installed in any location where EMT and FMC conduit is permitted to be installed.

C. PVC Coated RMC Installation Locations

PVC coated RMC conduit and PVC coated RMC fittings shall be installed in the following locations:

1. Underground conduit locations for elbows and bends with a radius of less than 36-times the conduit diameter.
2. Underground vertical risers extending above grade.
3. Entire length of underground conduits for the following circuits:
 - a. Audio microphones
 - b. Lighting dimming controls
4. Installed in contact with earth or corrosive materials.
5. Exposed in "cold" rooms and "refrigerated" rooms, rooms with a maintained temperature below 65 degrees Fahrenheit.

D. EMT Installation Locations

EMT conduit and EMT fittings may be installed in the following locations, for circuit conductors operating below 600 volts to ground; locations containing only "non-hazardous materials"; only dry locations:

1. Concealed in hollow non masonry/non-concrete, metal stud frame and wood stud frame walls and floors.
2. Concealed above ceilings.
3. Exposed inside interior enclosed crawl spaces.
4. Exposed interior locations placed 9-feet or higher above finished floors (except as described in paragraph below at lower heights).
5. Exposed on walls and ceilings (any height) in the following dedicated function areas, interior enclosed room locations:
 - a. Indoor enclosed electrical equipment rooms and closets.
 - b. Indoor enclosed data and telecommunication terminal rooms and closets.
 - c. Indoor enclosed HVAC equipment rooms and closets.
6. Any location where FMC is described to be installed, except as the final connection to rotating or vibrating equipment.

E. FMC Installation Locations

FMC conduit and FMC fittings may be installed in the following locations for circuit conductors operating below 600 volts to ground; locations containing only "non-hazardous materials"; only dry, interior locations:

1. Concealed in hollow non-masonry metal stud frame and wood stud frame fully enclosed walls.
2. Concealed above fully enclosed ceiling spaces.
3. FMC conduit shall be installed in continuous lengths between termination points. FMC shall not be "spliced" or coupled directly to FMC or any other conduit type under any circumstance.

4. The maximum continuous length of FMC that shall be installed between termination end points is 15-feet. Circuits requiring continuous conduit lengths exceeding 15 feet between termination end points shall be installed using either RMC or EMT conduits. FMC lengths shorter than 16-inches are prohibited.
5. The minimum size FMC conduit shall be as shown on the Drawings but not be less than the following:
 - a. FMC lengths of 6-feet or less, minimum FMC conduit size shall be 0.50-inch.
 - b. FMC lengths exceeding 6-feet, minimum FMC conduit size shall be 1.0-inch.

F. LTFMC Installation Locations

LTFMC conduit and LTFMC fittings shall be installed in the following locations for circuit conductors operating below 600 volts to ground; locations containing only “non-hazardous materials”:

1. Final electrical connection to vibrating or rotating equipment; control and monitoring devices mounted on vibrating and rotating equipment including the following. Minimum conduit length shall not be less than 24-inches:
 - a. Motor, engines, boilers, solenoids, and valves.
 - b. Fixed mounted “shop” (manufacturing) production equipment.
 - c. Fixed mounted food preparation equipment and “kitchen” equipment.
2. All locations where exposed flexible conduit connections are required, both indoor and outdoor.
3. Final connection to indoors electrical transformers. Minimum conduit length shall not be less than 24-inches; maximum conduit length shall not exceed 72-inches.
4. Do not install LTFMC located in environmental air plenums.

G. RNMC Installation Locations

RNMC conduit and RNMC fittings shall be installed in the following locations containing only “non-hazardous material”:

1. Underground, concealed below earth grade, unless specifically noted or specified otherwise.
2. Exposed on utility service poles, for pole risers at 9-feet or higher above finish grade, Schedule 80 PVC only.
3. RNMC Type “EB” conduit(s) shall be concrete encased along the entire length of the conduits for all installation locations.
4. Non-metal type raceways and RNMC type conduit shall not be installed inside buildings.

H. Combi-Duct Installation Locations

Combi-duct conduits shall be installed where shown on the Drawings. Combi-duct shall be installed underground (below grade) as follows:

1. Do not install exposed or inside buildings above grade.
2. Provide a 0.25-inch pull rope in each inner duct.
3. Radius and elbows shall be rigid non-metallic, PVC, Manufacturer factory fabricated, in lieu of PVC coated RMC conduit.

4. Inner ducts shall be supported by internal spacers inside the enclosing outer duct.
 5. Provide end bell and three hole "snug-plugs" at each entrance end of Combi-duct into pullboxes, manholes, equipment cabinets stub-ups and Combi-duct terminations. Compression type "snug-plugs" shall provide watertight and airtight seal between inner and outer ducts and around future cables installed in inner duct.
- I. Conduit Installation
1. Conduit Supports
 - a. Securely and rigidly support all raceways/conduits from the building structure. Raceways/Conduits shall be supported independent of all piping, air ducts, equipment ceiling hanger wires, and suspended ceiling grid systems. Secure conduit to structural element by means of UL listed and approved hangers, fasteners, "C" channels and pipe clamps.
 - b. Provide conduit supports spaced along the length of the conduit as follows:
 - 1) RMC and EMT conduit, maximum not to exceed 96-inches on center; within 24-inches of each conduit bend and conduit termination location.
 - 2) FMC and LTFMC conduit, maximum not to exceed 24-inches on center; within 6-inches of each conduit bend and conduit termination location.
 - c. Suspended conduit methods:
 - 1) Individual, suspended raceways/conduits separated by more than 12-inches from any other conduit and suspended from ceilings and roofs shall be supported as follows:
 - a) Conduits smaller than 1.5-inches by means of hanger rods or hanger wires.
 - b) Conduits 1.5-inches and larger by means of hanger rods.
 - c) The conduit shall attach to the hangers with pipe clamps.
 - 2) Suspended raceways/conduits positioned within 24 inches of any other conduit shall be grouped and supported by hanger rods using trapeze type conduit support channels ("C" channels). Conduits shall individually attach to common channels side-by-side, with pipe clamps.
 - d. Non-suspended conduit methods:
 - 1) Individual raceway/conduits placed against wall/ceiling/floors, placed inside hollow wall/ceiling construction or structure framing (i.e., "dry- wall" or plaster hollow wall construction), shall be secured by means of individual pipe clamps and fasteners attached to the framing studs or other structural members and the conduit/raceway.
 - 2) Provide common "C" channel supports for all multiple raceway/conduits placed against vertical or horizontal surfaces and positioned within 24-inches of other raceways/conduits. Attach channels to the framing studs or other structural members. Attach the conduits/raceway individually to common channels, side-by-side, with pipe clamps.
 - 3) The use of toggle bolts is prohibited.
 - e. Conduit rising from floor for motor connection shall be independently supported if extending over 18-inch above floor. Support shall not be to a motor or ductwork, which may transmit vibrations.

- f. Provide conduit anchoring, conduit support and conduit bracing systems conforming to Earthquake Seismic Zone 4 Requirements. The conduit support/anchoring system capacity shall include the weight of the conduits, conduit fittings, conduit supports, and conductors/wires/cables installed in the conduits plus a 300% safety factor. Submit Shop Drawing details showing each typical conduit anchor, conduit support and conduit brace location. Submit structural calculations performed by and signed by a Professional Structural Engineer (P.E.) with a P.E. license, registered in the State of California, U.S.A.
2. Conduit separation:
- a. Conduit installed underground or below building slab without full concrete encasement: Shall be separated from adjacent conduits of identical systems (i.e., signal to signal, data to data, power to power, control to control etc.) by a minimum of 3-inches. Conduits of non-identical systems (i.e., signal to power; data to power; power to control; signal to control, etc.) shall be separated by a minimum of 12-inches.
 - b. Conduit installed underground with full concrete encasement; shall be separated from adjacent conduits of similar systems (100 volt and less) by a minimum of 2-inches; conduits for non-power systems (100 volts and less to ground) shall be separated by a minimum of 6-inches from power circuits (over 100 volts to ground); conduits for power circuits shall be separated from adjacent conduits of similar power systems (over 100 volts to ground) by a minimum of 3-inches.
 - c. Separation of conduits entering termination points or crossing other conduits may be reduced as required within 60-inches of the termination or crossing points.
 - d. Conduits containing Utility Company service circuits (i.e., electrical power, telephone, or cable television) shall be separated a minimum of 12-inches from all other utilities and conduits, with or without concrete encasement, metallic or non-metallic conduit, above grade or underground conduit locations.
 - e. Conduits shall be separated from hot water piping, exhaust flues/chimneys, steam piping, boilers, furnaces, ovens by a minimum of 12-inches.
3. Conduit stubs:
- a. Branch circuit and telephone conduits turned up from floor at the following locations shall terminate each conduit in a flush conduit coupling at the floor and then extend into partition or to equipment. Refer to District's Representative's Drawings for location of walls and partitions.
 - 1) Interior demountable partitions.
 - 2) Below, into or adjacent to equipment not installed directly adjoining to a wall.
 - 3) Up from below the floor into hollow stud frame walls.
 - b. From each panel, and signal cabinet which is wall mounted, stub up from top of the panel/cabinet a minimum of three 1-inch conduits to the nearest accessible ceiling spaces or other accessible location. Where the floor below the panel is accessible or is a ceiling space, stub an additional three 1-inch conduits from the bottom of the panel into the accessible space below the panel. Cap conduits for future use.
 - c. Conduits stubbed underground outside of building line for future use shall be terminated a minimum of five feet clear (whichever distance is greater) of building

or adjacent concrete walks and AC paving. The stubout conduit shall be capped. Provide concrete monuments, 6-inches by 6-inches by 15-inches deep, buried flush with grade over the capped ends. The face of monument shall be furnished with 3-inch square brass plates securely mounted and engraved with the number and size of conduits and type of service (i.e., "POWER", "TEL.", etc.).

- d. Conduits stubbed into ceiling or floor spaces from outlets for telephone, video, computer/data or television shall be provided with an insulated throat bushing, on the end of each conduit stubout.
 - e. Conduit stub-outs from outlet boxes and equipment located in hollow stud walls, into ceiling and floor spaces, shall be EMT or RMC conduit. The stub-outs shall terminate into the ceiling and floor spaces with a conduit termination connector fitting.
 - f. Empty conduit stubs into building spaces and equipment shall be individually identified with an "ID-tag" located at each end of the conduit. The ID-tag shall state the origination point and termination point of the respective conduit (i.e., "from PNL-A/to Room #121"; "from outlet #24/to outlet #17 in Room #120"; etc.).
 - g. Provide a conduit termination fitting with insulated throat bushing and mechanical ground lugs at each conduit "stub-up" location.
4. Conduit concrete encasement:
- a. Conduits which are run underground exterior to building slab shall be continuously concrete encased except, 15-amp and 20-amp power branch circuit conduits underground do not require concrete encasement.
 - b. PVC rigid-non-metallic-type EB conduit, of any size and any location shall be continuously concrete encased the full length of the conduit installation, including under building slab.
 - c. Concrete for encasement of underground conduits shall be 2000-PSI 28-days cure strength with a mix of cement, sand, water and maximum of ¾-inch gravel. Concrete encasement of conduits shall be continuous without voids. The encasement shall extend 3-inches past the edges of all conduits on all sides of the circuit. Provide ten pounds of red oxide cement coloring uniformly mixed with each cubic yard of concrete for conduit encasement.
 - d. Conduits located below or adjacent to structural foundations shall be separated from the foundation by a minimum of 12-inches. Conduits located below structural foundations shall be fully and continuously concrete backfilled and encased between the bottom of the foundation to the bottom of the conduits. The concrete shall be 4000 PSI 28-day cure strength instead of 2000-PSI concrete.
 - e. Conduits of any size and type (including 15 amp and 20-amp power branch circuits) located under roads, paved areas and "transit-system" right of way shall be concrete encased.
5. Underground conduits:
- a. Three or more underground conduits larger than 1-inch in size and occupying the same trench shall be separated and supported on factory fabricated, non-metallic, duct/conduit support spacers. The spacers shall be modular, keyed interlocking type, "built-up" to accommodate quantity, size orientation and spacing of installed

conduits. The spacers shall maintain a constant distance between adjacent conduit supports and hold conduits in place during trench backfill operations. Minimum support spacer installation interval along with length of the conduits shall be as follows:

- 1) Concrete encased conduits, not less than 8-feet on center.
 - 2) Non-concrete encased conduits, not less than 5-feet on center.
- b. Provide trenching, excavation, shoring and Backfilling required for the proper installation of underground conduits. Tops of backfill shall match finish grade.
- c. Bottoms of trenches shall be cut parallel to “finish grade” elevation. Make trenches 12-inches wider than the greatest diameter of the conduit.
- d. Back-filling Trenches for Conduits without Concrete Encasement Requirements
- 1) Conduits which are not required by the Contract Documents to be concrete encased and are located exterior to building slab, shall be set on a 3-inch bed of damp clean sand. Conduit trenches shall be backfilled to within 12-inches of finished grade with damp sand after installation of conduit is completed. Remainder of backfill shall be native soil.
 - 2) Conduits located under a building which are not required by the Contract Documents to be concrete encased, shall be completely backfilled and compacted with clean damp sand to the same level as the building foundation pad.
 - 3) Provide a continuous yellow 12-inches wide flat plastic tracer tape, located 12-inches above the conduits in the trench. The tracer tape shall be imprinted with “Warning-Electric Circuits” a minimum of 24-inches on center.
- e. Backfilling trenches for conduits under paved areas:
- 1) In addition to the Requirements of conduit concrete encasement, conduits under walkways, roads, parking lots, driveways, and buildings shall be cast in place concrete “slurry mix” backfill. The slurry mix shall cover each side and top of conduits and conduit concrete encasement. The slurry mix shall be continuous to the underside of the finish subgrade surface.
- f. Backfilling trenches for conduits with Concrete Encasement Requirements by the Contract Documents:
- 1) Trenches with all conduits concrete encased shall be backfilled with clean damp sand when located under building pads.
 - 2) Trenches with all conduits concrete encased and not located under a building pad and not located under paved areas shall be backfilled with clean damp sand or native soil.
- g. Backfill material:
- 1) Sand and native soil backfill of trenches shall be machine vibrated in 6-inch lifts to provide not less than 90% compaction of backfill.
 - 2) Soil backfill shall have no stones, organic matter of aggregate greater than 3-inches.
 - 3) Concrete and slurry mix (2000-PSI) shall be machine vibrated during installation to remove “air-voids”.

- 4) The slurry mix shall consist of concrete, clean rock, clean sand and clean water mixture. Maximum shrinking of slurry mix shall not exceed 5% wet to dry.
- h. Do not backfill until District's Representative has approved Installation and As-Built Drawings are up to date. Promptly install conduits after excavation has been done, so as to keep the excavations open as short a time as possible. Excess soil from trenching shall be removed from the site.
- i. Install underground conduit, except under buildings, not less than 24-inches below finished grade in non-traffic areas and 30-inches below finished grade in traffic areas, including roads and parking areas. Not less than 48-inches below finished grade under public/private transit system right of way and railroad right of way. Dimensions shall be measured to the top of the conduit.
- j. Conduit crossing existing underground utilities shall cross below the bottom depth of the existing utilities. If the top portion of the existing utility depth below finish grade exceeds 72-inches and the specified separation and depths are maintained when crossing over the top of the existing underground utility, the conduit may cross above the existing underground utility.
- k. Provide long radius horizontal bends (minimum radius of 36-times the conduit diameter) in underground conduits where the conduit is in excess of 100-feet long.
- l. Conduits installed below grade and on grade below buildings, shall not be smaller than 0.75-inches. Conduits for circuits exceeding 600-volts shall not be smaller than 5.0-inches.
- m. Underground conduits entering a building shall be sloped. The conduit direction of slope shall be away from the building and shall prevent water in the conduit from "gravity draining" towards the building. The conduit slope "high point" shall originate from the building, out to the first exterior pullbox, manhole etc. exterior conduit termination "low point". The minimum slope angle shall be a constant 8-inches (or greater) of fall for each 100-feet of conduit length.
- n. Dewatering:
 - 1) Provide pumping to remove, maintain and dispose of all water entering the excavation during the time the excavation is being prepared, for the conduit laying, during the laying of the conduit, and until the backfill at the conduit zone has been completed. These provisions shall apply on a continuous basis. Water shall be disposed of in a manner to prevent damage to adjacent property. Trench water shall not be drained through the construction. Groundwater shall not be allowed to rise around the pipe until joining compound has firmly set.
 - 2) The District's Representative shall be notified 48 hours prior to commencement of dewatering.
6. Raceway/Conduits, which are installed at this time and left empty for future use, shall have 0.25-inch diameter polyvinyl rope left in place for future use. The pull rope shall be 500-pound minimum tensile strength. Provide a minimum of 5-feet of slack at each end of pull ropes.

7. Unless otherwise restricted by Structural Drawings and specifications, the maximum size conduit permitted in concrete slab on-grade, walls, ceilings and roofs constructed of masonry or concrete shall not be greater than 20% of the concrete/ masonry thickness. Conduits installed in these locations shall not cross.
 - a. Conduits shall not be installed in cast-in-place concrete floors.
8. Provide openings in building structures for conduit penetrations:
 - a. New construction shall be provided with conduit sleeves, to provide conduit penetrations.
 - b. Existing construction shall be drilled (core drill masonry and concrete) and provide conduit sleeves installed after drilling, to provide conduit penetrations.
 - c. Where the structure penetrations for underground conduits penetrating through foundations will not comply with the (restriction/penetration) shown in the Contract Documents, install the conduits below and clear of the foundation lowest point.
9. Conduit bends risers and offsets:
 - a. The minimum bend radius of "factory or field" fabricated conduit bends shall not be less than the following. The bend radius shall be measured at the surface, inside radius of the conduit wall:
 - 1) FMC and LTFMC conduit - conduit minimum bend radius 12-times the conduit diameter.
 - 2) RMC and EMT conduit minimum bend radius - conduit for power circuits over 100 volts and less than 600 volts, 8-times conduit diameter. Conduit for power circuits over 600 volt, 12-times conduit diameter. Conduit for low voltage, signal and fiber optic circuits, 10-times conduit diameter.
 - 3) RNMC conduit - conduit minimum bend radius 36-times the conduit diameter. Under building reduce minimum bend radius to 10-times the conduit diameter. Conduit bends and offsets in RNMC with less than 36-times conduit diameter bend/offset radius shall be RNMC PVC Schedule 80 or PVC coated RGS.
 - 4) Conduits for Utility Company conductors. Conduit minimum bend radius shall comply with the respective Utility Company Requirements.
 - b. Bends and offsets in conduits shall be kept to an absolute minimum. The total summation of all bends and offsets permitted in a conduit segment, occurring between two conduit termination/connection end points, shall not exceed the following, including conduit fittings:
 - 1) RMC and EMT conduit - 360 angular degrees
 - 2) FMC and LTFMC conduit - 180 angular degrees
 - 3) RNMC conduit - 270 angular degrees
 - c. Each field fabricated conduit offset, bend and elbow which are not the standard product of the Raceway/Conduit Manufacturer shall be mandrel tested. The test shall be conducted after the conduit installation is complete and prior to pulling-in any wire, in the same manner as for underground conduits.
 - d. Factory manufactured angle connector conduit fittings shall be installed in exposed conduit locations only. Installation in locations normally concealed from view shall

not be permitted. Not more than one factory manufactured angle connector shall be permitted in any length of conduit between conduit termination end points.

- e. RNMC conduit risers from below grade shall be PVC coated RGS. Conduit risers, bends or offsets entering into a building shall be PVC coated RGS.
- f. If three or more conduit-bends of the same conduit size and same conduit material type, installed, as part of the Contract Work, fail to comply with the required minimum conduit bend radius or conduit angular degree limits. The following corrective actions shall occur:
 - 1) The Contractor shall remove all the non-complying conduit bends and the respective wire in the conduit from the project site. Provide new conduit and wire, complying with the Contract Documents.
 - 2) Where the conduit bends similar to the non-complying conduit bends are installed concealed in walls, floors, above ceilings or below grade, the Contractor shall expose the conduit bends to allow visual observation.
 - 3) The Contractor shall remove the non-complying conduit bends and dispose of the Project site. The Contractor shall provide new conduit bends and conductors complying with the Contract Documents.
 - 4) All the costs to correct the deficient material and work along with costs to repair the direct, indirect, incidental damages and contract delays shall be the sole responsibility of the Contractor and shall be included in the bid price.

10. Expansion joint, deflection joint and seismic joint fittings.

- a. Provide a conduit expansion fitting for each conduit length and conduit type as follows (Note - The installation of specified combination expansion/deflection fittings at seismic joints shall satisfy this Spacing Requirement also):

	<u>Conduit Type</u>	<u>Conduit</u>	<u>Fitting Length Spacing</u>
1)	RMC and EMT	Exposed exterior locations	200-feet
2)	RMC and EMT	Interior weather protected locations	400 feet

- b. Provide a conduit combination expansion/deflection fitting for each conduit, crossing the following elements:

- 1) At each building or non-building structure seismic joint.
- 2) At each building on non-building structure expansion joint.
- 3) At each conduit penetration of a "sound-rated" wall, floor or ceiling.

- 11. Provide two locknuts and an insulated throat bushing at each metal conduit terminating at enclosures, including but not limited to outlet boxes, junction boxes, terminal cabinets, switchgear, transformers, switchboards, distribution panels and panelboards.
- 12. Provide metallic or plastic closure caps on all conduit ends during construction, until installation of conductors in the respective conduit.
- 13. Conduit run exposed, shall be run at right angles or parallel to the walls or structures. All changes in directions, either horizontally or vertically, shall be made with conduit outlet bodies as manufactured by Crouse Hinds, OZ or equal. Conduits run on exposed beams or trelliswork shall be painted to match surrounding surfaces.

14. Conduit exposed on roof:
 - a. Conduits installed exposed on roofs shall be installed on conduit sleepers. Place the conduit sleepers a maximum 5-foot on center along the entire length of the conduit; under conduit expansion/deflection fittings; under each junction box and within 24-inches of each conduit bend.
 - b. Provide a conduit support "C" channel continuous along the top length of the sleeper and rigidly bolted to the sleeper. Conduits shall be loosely fastened to each sleeper "C" channel with pipe clamps to allow for relative movement between the sleeper and conduit.
 - c. Conduits shall not block or interfere with roof hatches, doors, ventilation openings, dampers, equipment access panels/doors, roof water drainage.
 - e. Conduit sleepers shall be fabricated from "clear" solid redwood 4-inches by 4-inches (nominal) size. Sleeper length shall extend a minimum of 9-inches past the conduits attached to the sleeper, but in no case shall the length of the sleeper be less than 24-inches.
 - f. Provide a pad under each sleeper; sleepers shall not be installed in direct contact with the roofing. Sleeper pads shall extend a minimum of 6 inches past each side of the sleeper. The sleeper pad shall be semi-rigid mineral surfaced composition board, not less than 0.375-inch thickness, bituminous impregnated, manufactured for application on the specific roofing material. Remove roofing "ballast" (gravel) under pad, prior to installation of sleeper pad. Do not puncture roof membrane.
 - g. Position the "length" of the conduit sleepers' perpendicular to the roof slope, to prevent obstruction of roof drainage water flow. Where the conduit routing prevents placing the conduit sleeper parallel to the roof slope, provide two separate sleeper pads for the conduit sleeper, with a continuous 3-inches wide water drainage gap between the sleepers. Align the water drainage gap to allow unimpeded water travel along the roof slope drainage flow line between the pads.
 - h. Sleepers and sleeper pads shall be set in nonhardening mastic, a minimum of 0.25-inch thickness. Mastic shall be inorganic, nonhardening, and complying with ASTM-D1227. Mastic shall be applied with continuous uniform coverage, minimum 0.25-inch thickness, on all the surfaces of each conduit sleeper and on the sleeper pad contact surface with the roof.
15. Rigid steel conduit or electrical metallic tubing shall not be strapped or fastened to equipment subject to vibration or mounted on shock absorbing bases.
16. RMC conduit threads:
 - a. Machine cut threads on RMC conduit required for field fabrication shall comply with NPS and ANSI-B1.20.1.
 - b. The length of bare metal exposed during thread fabrication shall be completely covered by conduit couplings and fittings. Additionally, the thread length shall insure that conduit joints will reach "torque" tightness and become secure before conduit ends "butt" together and before conduit ends "butt" into the "shoulders" of other conduit fittings.
 - c. Running threads or right/left-handed threads shall not be used to connect RMC.

17. RNMC conduit:
 - a. Joints and fittings shall be solvent welded to RNMC conduit. Joints and fittings shall be watertight and airtight after fabrication.
18. Tighten each conduit fittings and fitting appurtenance, to the “torque” (allowable tolerance $\pm 5\%$) value recommended by the Fitting Manufacturer and applicable Code. If three or more conduit fittings are found to not be in compliance with the Manufacturer’s “torque” (tightness) recommendations, the following corrective actions shall occur:
 - a. The Contractor shall tighten “re-torque” the defective fittings and all similar conduit fittings installed as part of the Contract Documents in the presence of the District’s Representative.
 - b. If the respective conduit fittings similar to the deficient “torque tightness” fittings are installed concealed in walls, floors, above ceilings or below grade, the Contractor shall expose the fitting, to allow retightening each similar conduit fitting to the Manufacturers recommended “torque” values.
 - c. All the cost to repair the direct, indirect, incidental damages and contract delays resulting from complying with these Requirements shall be the sole responsibility of the Contractor and shall be included in the bid price.
19. Horizontal directional boring for underground conduit:
 - a. Provide a directional guided horizontal “bore-hole” underground conduit installation where one or more of the following conduits occur:
 - 1) Continuous trenching excavation and backfill for conduit installation is not permitted by the Contract.
 - 2) Where continuous trenching excavation due to the existing surface and below grade conditions and restrictions, is not possible or practical to excavate a trench.
 - b. Provide “path-tracing” of the underground bore head, from the surface, along the entire horizontal bore length. Path tracing shall use electronic transmitters and receivers, continuously communicating the underground bore head locations and depth to the bore equipment operator. The directional boring system shall employ active tracking and directional position/steering control of the bore equipment drill head location. The active tracking system shall provide a portable receiver / transmitter unit for tracking the position of the moving drill head; a sensor “Sonde” unit on the drill head for tracking signals to the receiver/transmitter; and a drill head tracking data view display located at the boring equipment operator position to view the drill head position information sent from the portable receiver/transmitter. As manufactured by SPX-Radiodetection Company or similar products.
 - c. Provide vertical pilot excavations not more than 50-feet on center along the path of the borehole to intercept the horizontal bore-hole routing, provide excavations at the beginning and end terminals staging points of the horizontal borehole.
 - d. Provide full depth “shoring” of the vertical pilot excavations. Remove the shoring, backfill, compact and repair the excavations when conduit installation is complete.
 - e. “Drilling-fluid” shall be used during “back-reaming” and “pullback”, pumped through the drill pipe to the bore drill head.

- f. Directional guided horizontal drilling shall employ equipment specifically designed and manufactured for the process. The Equipment Manufacturer shall train bore equipment operating personal in the proper operation of said equipment.
- g. Locate the position, size, depth and identify all underground “cross-bore” existing underground utilities, pipes, structures, and conflicts along the entire bore path of each underground bore, prior to initiating directional boring work. Notify respective agency for each “cross bore” potential crossing. Comply with the recommendations of the Cross Bore Safety Association (CBSA).
- h. Horizontal, directionally guided boring equipment, as manufactured by Ditch Witch; Vermeer Manufacturing; or Case Corporation.

J. Conduit Seals

- 1. Provide conduit seal fittings at each location where a conduit transitions or passes through the following areas and where indicated on the Drawings:
 - a. Refrigerated areas.
 - b. Temperature control rooms including warming rooms, steam rooms, saunas etc.
 - c. Classified hazardous material areas.
 - d. Water intrusion areas.
- 2. Provide conduit seals on each conduit entering a building from a below grade area located outside the building (i.e., basement, vault etc.) and connecting to the following types of equipment
 - a. Transformers
 - b. Panelboards
 - c. Motor control centers
 - d. Switchboards
 - e. Switchgear
 - f. Motors
 - g. Terminal cabinets
 - h. Terminal backboards
 - i. Cable trenches
- 3. Conduit seals shall be installed in locations where the fitting is visible and accessible.

K. Nailing Shields

- 1. Provide “nail” shields where FMC conduit and conductors not installed in a conduit are installed through wood stud and wood frame construction. The nail shield shall provide a barrier resistant to “nailing” fasteners through the stud and penetrating into the FMC and conductors.
- 2. The nail shields shall be flat nominal 1.5-inch by 3-inches, 14-gauge steel, and hot dip zinc galvanized with “nailing spurs”.
- 3. Provide nailing shields on the front face and rear face of each FMC penetration. The shield shall be centered on each penetration through the respective framing, stud framing blocking, and stud framing plates.

L. Conduit Bodies

1. Conduit bodies shall be installed in exposed conduit locations only or above accessible ceilings.
2. Conduit bodies shall be accessible for removing body cover and pulling wire through the conduit body.
3. Conduit bodies shall not be installed inside enclosed walls.

M. Preparation of Reuse of Existing Conduits

1. Prepare existing conduits shown to be reused as part of Contract Work as follows: Complete the required work prior to installing any conductors or cables in respective existing conduits.
 - a. "Rod" out existing raceways to be used under this contract, with approved test and flexible mandrels to remove all obstructions to clear debris from inside conduits.
 - b. Use test mandrels at least 12-inches long, 0.25-inch less than diameter of duct at center, tapering to 0.5-inch less than duct size at ends.
2. If test mandrels cannot be pulled through raceways, Contractor shall perform the following to clear the existing raceways:
 - a. Force rigid or semi-rigid rods through the raceways to clear the obstructions from one to both ends of the raceway.
 - b. Force a power-driven rotating router device through the conduit from one or both ends of raceways. Device shall incorporate small diameter cutting blades. Repeat the "router" process in incremental stages to a cutting blade diameter approximately 1/8-inch smaller than the raceway inside diameter.
3. After clearing the raceway of obstructions, pull a test mandrel or brush through the raceway to clear the remaining debris from the raceway.

3.04 WIRE AND CABLE

- A. Branch circuit and fixture joints for #10AWG and smaller wire shall be made with UL-approved connectors listed for 600 volts, approved for use with copper and/or aluminum wire. Connector to consist of a cone-shaped, expandable coil spring insert, insulated with a nylon shell and two wings placed opposite each other to serve as a built-in wrench or shall be molded one-piece as manufactured by 3M-"Scotchlok".
- B. Branch circuit joints of #8AWG and larger shall be made with screw pressure connectors made of high strength structural aluminum alloy and UL-approved for use with both copper and/or aluminum wire as manufactured by Thomas & Betts. Joints shall be insulated with plastic splicing tape, tapered half-lapped and at least the thickness equivalent to 1.5-times the conductor insulation. Tapes shall be fresh and of quality equal to Scotch.
- C. Use UL listed pulling compound for installation of conductors in conduits.
- D. Correspond each circuit to the branch number indicated on the panel schedule shown on the Drawings except where departures are approved by the District's Representative.
- E. All wiring, including low voltage, shall be installed in conduit.
- F. Control wiring to conform to the wiring diagrams shown on the Mechanical Drawings and the Manufacturer's wiring diagrams.

- G. All splices in exterior pull boxes and light poles shall be cast resins encapsulated.
 - 1. Power conductor splices - 3M Scotchcast Series 82/85/90; Plymouth or equal.
 - 2. Control and signal circuits 3M Scotchcast Series 8981 through 8986, Plymouth or equal.
- H. Neatly group and lace all wiring in panelboards, motor control centers and terminal cabinets with plastic ties at 3-inch on centers. Tag all spare conductors.

3.05 CABLE RACKS

- A. General
 - 1. Provide cable racks in precast and cast-in place concrete pullboxes, manholes and cable trenches.

3.06 TESTING

- A. Testing Conduit and Conduit Bends

The Contractor shall demonstrate the usability of all underground raceways, and field fabricated conduit bends installed as part of this Contract.

- 1. A round tapered segmented semi-rigid mandrel with a diameter approximately ¼-inch smaller than the diameter of the raceway, shall be pulled through each new raceway.
- 2. The mandrel shall be pulled through after the raceway installation is completed. Conduits which stubout only, may have the mandrel pulled after the concrete encasement is completed, but prior to completing the backfill.
- 3. District's Representative shall witness the raceway testing for usability. A Representative of the respective Utility Company shall witness the raceway testing where applicable.
- 4. Contractor shall repair/replace any conduit and conduit bend provided under this contract which will not readily pass the mandrel during this test.

END OF SECTION 26 05 33
021821/212276

SECTION 26 24 13
SWITCHBOARDS

PART 1 - GENERAL

1.01 SCOPE

- A. Work Included: All labor, materials, appliances, tools, equipment necessary for and incidental to performing all operations in connection with furnishing, delivery and installation of the work of this Section, complete, as shown on the Drawings and/or specified herein. Work includes, but is not necessarily limited to the following:
1. Examine all other Specification Sections and Drawings for related work required to be included as work under Division 26.
 2. General Provisions and Requirements for electrical work.

1.02 SUBMITTALS (ADDITIONAL REQUIREMENTS)

- A. Provide schematic "ladder type" logic control wiring diagrams and "point-to-point control wiring diagrams showing control and protective systems interlocks.
- B. Provide nameplate engraving schedule.
- C. Submit full-scale time/current transparencies on log/log paper for all fuses, circuit breakers, ground fault system devices, and relays. Additionally, provide software to generate time/current curves of each circuit protection device.
- D. Short Circuit, Coordination and Arc-Flash
1. Perform and submit engineered settings for each equipment location, fuse and circuit breaker device, showing the correct time and current settings to provide the selective coordination within the limits of the specified equipment, per the latest applicable standards of IEEE and ANSI. Provide electrical system short circuit fault analysis, both 3-phase line-to-line and 1-phase line-to-ground calculations as part of the coordination analysis recommendations. Provide Electric Arc-Flash calculations as part of the coordination analysis recommendations.
 2. The information shall be submitted in both tabular form and on time current log-log graph paper, with an Engineering Narrative. Written narrative describing data, assumptions, analysis of results and prioritized recommendations, six copies.
 3. The goal is to minimize an unexpected but necessary electrical system outage and personnel exposure to the smallest extent possible within the fault occurrence location, using the specified Contract Equipment. Shall comply with, but not limited to:
 - a. IEEE-242, Recommended Practices for Protection and Coordination of Industrial and Commercial Distribution.
 - b. IEEE-399, Recommended Practice for Industrial and Commercial Power System Analysis.
 - c. IEEE-1584, Guide to Performing Arc-Flash Hazard Study.
 - d. CEC/NEC
 4. Electrical equipment including switchgear, switchboards, electric panels and control panels, motor control centers, combination motor starters, transformers, disconnects,

etc., shall each be labeled by the Manufacturer with “Electric-Arc-Flash” warning signs. The signs shall explain a hazard to personnel may exist if the equipment is worked on while energized or operated by personnel while energized. The sign shall instruct personnel to wear the correct protective equipment/clothing (PPE) when working “Live” or operating “Live” electrical equipment and circuits.

- E. Factory Tests: Equipment tests - ANSI C37.20. Certified copies of design tests, production tests, and conformance tests of the equipment shall be submitted, and review comments shall be received before delivery of equipment to the Project site. In lieu of the above tests, a report of these tests previously performed on identical units of each rating will be acceptable.

1.03 APPLICABLE STANDARDS

- A. The switchboard and switchgear equipment shall be designed, tested, and assembled to comply with ANSI, IEEE, and NEMA and UL.
- B. Seismic Earthquake and Wind Loading Withstand, Testing and Certification (Additional Requirements).
 - 1. The complete switchboard/switchgear assembly; including circuit protection devices, meter, housings/enclosures, accessories, supports/anchors etc., shall be designed, manufactured, and tested.
 - a. Wind loading all outdoor equipment locations.
 - b. Earthquake Seismic Requirements of CBC/IBC Seismic withstand all indoor and all outdoor equipment locations.
 - 2. Shall withstand, survive and maintain continuous non-interrupted energized operation during the seismic event occurrences and wind event occurrences. Continued normal energized operation after the wind event and seismic event occurrences have abated.
 - 3. Shall include demonstrations of successful operation and run test after completion of seismic event shake-table simulation. Acceptance tests seismic qualification of proposed switchboard and/ or switchgear shall employ triple axis shake-table simulation of the Required Response Spectrum (RRS) seismic event motion, certified and approved by the AHJ.
 - 4. Provide three-dimensional finite element analysis demonstrating anchorage and operational withstand of wind loading not less than as follows and as required by AHJ:
 - a. 100MPH-West Coast States USA, California, and Hawaii, per ASCE/SEI 7-10.
 - 5. Seismic test shall be performed by a third-party independent test laboratory. Wind analysis and seismic Testing and reports shall be certified, signed and “stamped” by PE Professional Engineer licensed and in good standing in the State, Civil Engineer or Structural Engineer.
- C. Equipment components/devices, switchboards, and/or switchgear shall be manufactured by: Eaton, Square-D; or Siemens.

PART 2 - PRODUCTS

2.01 BUSSING

- A. Horizontal and vertical busses shall be full lengths in each equipment section. Buses shall have a minimum short circuit fault withstand rating equal to available fault current indicated on Drawings, plus a 25% additional capacity (safety margin). However, in no case shall the rating be less than 50,000 amp, symmetrical.
- B. Provide interconnected full capacity neutral bus in each section with the same ratings and construction as the phase busses.
- C. Provide interconnected ground bus in each section.
- D. Provide space and all hardware and mounting attachments for future devices as indicated on the Drawings.
- E. Main horizontal phase and neutral bussing shall be full capacity in all equipment sections. The through bus of the end distribution section shall be extended and pre-drilled to allow the addition of future sections.
- F. Vertical riser buss may be tapered, to not less than one third the ampacity rating of the main horizontal buss; but in no case shall the vertical buss be of less capacity than the sum of the frame size ampacities of overcurrent devices mounted in the respective sections including any indicated spares and spaces.
- G. The equipment bussing shall be of sufficient cross-sectional area to meet UL Standard 891 on temperature rise Bus shall be copper with silver plated bus joints or extruded aluminum with tin plated bus joints. The through bus shall have provisions for the addition of future sections. The through bus supports, connections and joints are to be bolted with Grade 5 hex head bolts and Belleville washers to minimize Maintenance Requirements.

2.02 CIRCUIT BREAKERS

- A. General
 - 1. Circuit protective devices as indicated on the Drawings. All devices shall have a short circuit interrupting capacity not less than the maximum available fault current at the circuit breaker and as indicated on the Drawings, plus a 25% additional capacity (safety margin). However, in no case shall the circuit breaker interrupting capacity be less than 30,000-amp symmetrical interrupting for 480/277 volt devices and 42,000 amp symmetrical for 240 volt or 208/120 volt devices.
 - 2. Provide padlock-off devices on each device. Breakers shall provide automatic time over-current and instantaneous circuit protection. Shall be suitable for use as "Main" service disconnect, "Feeder" and "Branch-Circuit" functions.
 - 3. Circuit breakers shall employ a self-powered stored energy, quick make-quick break, and trip free operating system on each phase, with common trip. Circuit breakers shall not trip in the event of short term or long-term electrical power failure. Dead front cover accessible close-open controls monitors and visual indicator flags.
 - 4. Circuit breakers noted as "100%" on the Drawings shall be tested and rated to carry the breaker full rated (100%) amp load continuously including the assemblies the circuit breakers are installed into.

5. Provide conductor lugs for circuit protection devices to accept conductor temperature rating, sizes and quantities shown on Drawings. Circuit protection devices shall be UL-listed suitable for normal and reverse feed.
6. Provide auxiliary contacts on circuit breakers. Auxiliary "DRY" contacts shall provide supervised remote monitoring of "Open-Close-Trip" circuit breaker status. Typical for circuit breakers supplying the following types of connected electrical loads.
 - a. Fire alarm equipment and devices.
 - b. Mass-evacuation equipment and devices.
 - c. HVAC smoke control and smoke evacuation equipment.
 - d. HVAC fire/smoke electrically operated dampers.
 - e. Intrusion detection and access control equipment and devices.
 - f. Elevators and escalators.
 - g. Fire sprinkler pumps.
7. Plug-in communications port for circuit breaker portable test instrument connects.
8. Circuit breaker data monitoring and communications:
 - a. The circuit protection devices shall monitor, communicate, and report circuit voltage, ampere, power, and harmonic parameters for the respective connected circuit. The circuit protection device monitors and communication parameters shall be the same and compatible with the specified "METERING" devices.
 - b. Additionally, the circuit protection devices shall monitor and communicate the respective device status as follows:
 - 1) Open/close/trip device status
 - 2) Ground fault trip status (where applicable)
 - c. Provide circuit breaker data monitoring and communications for each of the individual feeder protection devices and main protection devices located in switchgear and switchboards, rated 400 amp or greater trip rating.
 - d. The respective "METER" display selection control functions shall provide selection and display of all information monitored and communicated by individual protection devices on the respective meter alphanumeric display.
9. Circuit breakers shall be Power Circuit Breaker type, Insulated Case Circuit Breaker type or Molded Case Circuit Breaker type. Time/current and instantaneous characteristics and selection of circuit breaker type shall comply with the recommendations in the coordination study and ensure optimal Code mandated time/ current and instantaneous coordinated sequential tripping throughout the electrical system.

The Contract Document intent requires providing the selection and use of the circuit breaker types and performance characteristics for time/current and instantaneous trip coordination during electrical circuit overload conditions and during electrical short circuit fault conditions. Combined with the specified circuit breaker protection time/current performance characteristics.

 - a. Insulated Case Circuit Breaker type-ICCB:
 - 1) NEMA-AB1 and AB3, comply with latest revision.

- 2) UL-1087, UL-489 and IEC-60.947, comply with latest revision.
 - 3) 5Hz AC closing and 3Hz AC trip and clear.
 - 4) Hybrid combination of Molded Case Circuit Breaker type and Power Circuit Breaker type circuit breakers. ICCB enclosed insulated housing and limited internal maintenance access.
 - 5) Two-step stored energy close mechanism.
 - 6) Extended function on-off instantaneous trip selection.
 - 7) Push-to-trip button.
 - 8) Mechanical operations counter.
- b. Molded Case Circuit Breaker type-MCCB:
- 1) NEMA-AB1 and AB3, comply with latest revision.
 - 2) UL-1087, UL-489 and IEC-60.947.2 rated devices, comply with latest revision.
 - 3) 5Hz AC closing and 3Hz AC trip and clear.
 - 4) Sealed enclosed housing.
- B. Protection Performance Requirements for circuit breakers conforming to one or more of the following applications:
- 600 amp or larger frame size.
 - Larger than 400-amp trip.
 - Service entrance in main switchboard or switchgear.
 - Noted as Main or Main Circuit breakers on the Drawings.
1. Circuit breaker shall employ current sensors and solid-state static digital electronic automatic trip system. Three phase or single-phase operation as noted on the Drawings. Current carrying components shall be completely isolated from the static trip units. The trip unit shall be independent of external power sources. Circuit breakers shall be rated for reverse connection.
 2. Circuit breaker solid state digital trip control functions shall provide the following time/ current curve shaping field adjustable features.
 - a. Adjustable ampere setting to vary the long-time continuous current carrying capacity, minimum range of 80% through 100% of full load trip rating.
 - b. Adjustable long-time delay setting to vary the time the breaker will trip under sustained overload conditions. Minimum of three settings, "minimum – intermediate - maximum".
 - c. Adjustable short-time pickup to vary the level of high current the breaker can carry for short periods of time, minimum range of two times through eight times of ampere setting.
 - d. Adjustable short time delay varying the time of the short-time pickup. Minimum of three settings "minimum-intermediate-maximum".
 - e. Short time " I^2t " switch to allow a current-squared multiplied by time ramp function in the short-time system. Two position setting "in-out".
 - f. Adjustable instantaneous pickup to vary the breaker ampere setting for immediate (instantaneous) interruption of severe overloads (short circuits). Adjustable

minimum range of two times through nine times of circuit breaker ampere sensor rating. Instantaneous selective override trip setting shall also include “on-off” function. When “off”: or “override” is selected, shall then function with the adjustable short time delay and adjustable short time pick-up (Note where the coordination study requires a higher instantaneous setting, change the specified adjustable instantaneous trip to fixed instantaneous trip at fifteen times the breaker ampere sensor setting also with on-off function).

- g. Individual fault trip indicators (flags) shall provide local indication on the breaker for overload and short circuit (and ground fault where applicable) conditions.
 - h. Provide quantity of one, Manufacturer’s standard test set for solid state trip circuit breakers.
- C. Protection performance Requirements for circuit breakers conforming to one or more of the following applications:
- Smaller than 600-amp frame size.
 - 400 amp and smaller trip.
 - Larger than 100-amp frame size.
 - Larger than 100-amp trip.
1. Circuit breaker shall employ current sensors and solid-state static digital electronic automatic trip system. Time/current curve shaping field adjustable features.
 2. Solid state digital trip breakers shall conform to the Requirements described above for solid state breakers larger than 400-amp trip. However, only the following field adjustments are required.
 - a. Long-time ampere setting adjustable minimum range of 80% through 100% of full load trip rating.
 - b. Short time pickup adjustable minimum range of two times through eight times of the ampere setting.
 - c. Fixed or field adjustable instantaneous trip (depending on the results of the coordination study).
- D. Performance Requirements for circuit breakers conforming to the following applications:
- 100-amp frame size and smaller.
 - 100-amp and smaller trip.
1. Circuit breaker shall be fixed or adjustable instantaneous current trip with thermal-magnetic trip or with solid-state static digital electronic automatic time/over current automatic trip (depending on the results of the coordination study).
- E. Current Limiting Circuit Breakers (CLCB)
1. Protection Performance Requirements for circuit breakers conforming to the following applications:
 - 600 amp and smaller trip and identified as current limiting (CLCB) in the Contract Documents.
 - a. Current limiting circuit breakers shall be supplied in integral fully enclosed insulating housing construction and shall consist of a common trip, thermal-magnetic or solid state static digital trip conventional circuit breaker (depending on the results of the

coordination study), with an independently operating limiter section in series with each pole.

- b. The conventional breaker section shall have an over center, trip-free, toggle-type mechanism with quick-make, quick-break action and positive handle indication. A button shall be provided on the cover for mechanically tripping the circuit breaker. The current limiting breaker shall have permanent trip units containing solid state static digital trip or individual thermal and magnetic trip elements, in each pole. Calibrated for 40-degrees C ambient temperature. The limiter section shall consist of current limiting elements on each phase, electrically coordinated with the conventional circuit breaker trip elements. The contacts of the limiter section shall be electro-magnetically and electro-dynamically opened and held open until interruption is complete.
 - c. Current and Energy Limitations: On high-level fault currents the limiter portion of the circuit breaker shall operate to limit the rise of fault current. Integral resistance shall be introduced into the faulted circuit to dissipate and limit let-through energy and to provide a voltage transient-free interruption at near unity power factor. The Let-through short circuit fault current and energy levels shall be less than that permitted by Underwriters Laboratories to a value less than I^2t of a half cycle wave of the symmetrical prospective current. The CLCB limiter shall limit the asymmetrical short circuit fault current below the equipment symmetrical short circuit fault current.
 - d. On fault currents below the threshold of current limitation, the normal non-limiter breaker section shall provide conventional time /current overload and short circuit fault protection.
2. Protection Performance Requirements for circuit breakers conforming to the following applications:
- Trip ratings over 600-amp through 5000-amp or less. Identified as current limiting (CLCB) in the contract documents.
 - a. Integrally fused circuit breaker integrated with solid state static digital electronic automatic trip. Combined standard circuit breaker providing overload-short circuit protection within its interrupting capacity and ON-OFF switching function and on each phase current limiters internally mounted on the load side of the circuit breaker, of such ratings that their time current limiting characteristics will coordinate with the time current tripping characteristics of the circuit breaker elements.
 - b. The coordination shall result in the interruption by the circuit breaker alone of fault level currents up to the interrupting capacity of the circuit breaker and interruption by the current limiter in conjunction with the circuit breaker of fault level currents above the interrupting capacity of the circuit breaker.
 - c. A removable cover shall be provided over the current limiter section of the integrally fused circuit breaker. The current limiter housing covers shall be interlocked with the breaker tripping mechanism to ensure the breaker will trip upon removal of the cover. The cover shall be interlocked with the breaker to ensure the circuit breaker cannot be turned to the ON position with the cover removed. Current limiters shall have a spring-loaded plunger which, when the limiter blows, is released to actuate

the circuit breaker common trip bar mechanism opening all breaker poles simultaneously.

- d. The limiters shall be individually interlocked with the breaker element tripping mechanism to ensure the limiter cannot be inserted until the breaker is in the OFF position. The circuit breaker and limiters shall be interlocked to ensure the circuit breaker cannot be closed if a limiter is either missing or has blown.
- e. Fuse limiters shall be individually removable from the circuit breaker housing.
- f. The circuit breaker shall be ambient temperature compensating. The circuit breaker shall be provided with thermal magnetic or solid state static digital trip (depending on the coordination study).
- g. The integrally fused circuit breaker shall be capable of interrupting available short circuit currents up to 200,000 RMS symmetrical amperes at voltage up to 600 VAC.
- h. Ratings, clearances and performance of the integrally fused circuit breaker shall be in accordance with applicable standards of NEMA, IEEE and UL.

2.03 DISTRIBUTION SWITCHBOARDS

- A. Switchboards shall be floor mounted, dead-front, dead-rear type, front and rear aligned, self-supporting, consisting of one or more vertical sections with bussing, group mounted circuit protective devices, instrumentation and control wiring as indicated on the Drawings and as specified herein. Switchboards shall comply with UL Standard #UL-891 and NEMA-PB2.
 - 1. Distribution switchboards shall be service entrance rated and approved, when located in a building separate and remote from the main service entrance switchboard.
 - 2. Distribution Switchboards shall employ circuit breaker types and circuit protection devices as follows:
 - a. All Main circuit breakers of all frame sizes - ICCB type circuit breakers.
 - b. 800 amp and larger frame size Feeder circuit breakers, - ICCB; or MCCB type circuit breakers.
 - c. Smaller than 800-amp frame sizes Feeder circuit breakers - ICCB; or MCCB type circuit breakers.
 - d. CLCB type circuit breakers, only where noted on the Drawings.
 - e. CLF with switch and fuse type. CLF with switch and fuse type only where noted on the Drawings.
- B. Distribution switchboards shall include but not be limited to the following:
 - 1. Main disconnect device (where indicated on Drawings).
 - 2. Feeder protective devices.
 - 3. District metering (where indicated on Drawings).
 - 4. Bussing.
 - 5. Surge Protection Device (SPD).
- C. Switchboard sections
 - 1. Floor standing, self-supporting, of the universal frame type using die formed, 12-gauge steel members bolted and welded together.

2. Provide removable side and rear plates with formed edges all around.
3. Provide ventilation openings required for maintaining nominal operating temperature.
4. Provide removable steel cover plates for all usable device spaces. Provide lifting means and provisions for moving by means of rollers or skids to installation location.
5. Bolt individual sections together to form a single rigid switchboard assembly.
6. Provide full height, hinged, vertical wireway metal covers, on each vertical wireway, of each distribution section of the switchboard.

2.04 MISCELLANEOUS INSTRUMENTS

- A. Instrument and Control Transformers: ANSI C57.13 and NEMA ST20 as applicable. Transformers shall be specifically designed for use on respective protective relay or metering schemes utilized.
- B. Current transformers meter/relay grade shall be multi-ratio tap, tap setting as indicated on Drawings, (minimum of three field adjustable tap settings) with 5 amp secondary, insulation class, 600 volt, 60Hz, single ring type, and shall have an accuracy classification of 0.3 with the burden of B.01, B.02 and B.03.
- C. Control and transfer switches shall be of the rotary, oil-tight multi-position, cam-operated, multi-stage type, with dust cover and silver-to-silver contacts rated 600 volts, 20-amp and adequate for the duty performed in excess of 10amp. Equip each switch with engraved plastic escutcheon nameplate identifying its function and position.

2.05 CONTROL WIRING

- A. Terminal blocks with barriered terminals for each connection shall be provided for all control wiring terminator points. Control wiring shall be run in horizontal and vertical, isolated, internal metal wireways and shall be carried across hinges in laced bundles. Wire terminators shall be crimp-on type spade terminal.
- B. Secondary control wiring shall be a minimum of 14AWG stranded copper type SIS 600-volt insulation.
- C. Control circuits shall have circuit number tags at each termination or break in the wire to match circuit numbers on terminal strips and control wiring diagrams.

2.06 WEATHERPROOF EQUIPMENT

- A. Equipment indicated as weatherproof (W.P.) or outdoors should be NEMA 3R, non-walk-in, tamper resistant construction. Provide full height hinged doors with provisions for padlocking the doors in the closed position.
- B. Provide a nominal 300-watt sealed, resistance type, anti-condensation heater in each equipment section. Heaters shall be controlled automatically by Thermostats and Humidistats. A circuit breaker shall be provided to supply switchboard buss voltage to the heaters, all prewired by the Manufacturer to fused terminals.
- C. Finish shall be electrostatically applied finish paint over iron oxide rust inhibitor primer. Finish color shall be Manufacturer's standard color, olive green Munsel #7GY3.29/1.5. The bottom side and bottom 6-inches of the equipment shall be coated with 4-mil minimum thickness rust inhibitor undercoating over finish paint, on all interior surfaces.

Finish withstand test without face corrosion or blistering:

1. Salt spray withstands - 2000 hours ASTM B117.
 2. Humidity withstands - 750-hour ASTM D2247.
- D. Exposed Hardware and Hinges Shall be Stainless Steel Type 302 or 304, Tamper Resistant

PART 3 - EXECUTION

3.01 GENERAL

- A. Install equipment in accordance with Manufacturer's written instructions and applicable portions of NECA's "Standards of Installations" for switchboards, switchgear and motor control centers.
- B. Prior to energizing and testing, Manufacturer's Field Engineer shall visually inspect and verify devices are operational and bus connects complete.

3.02 ANCHORING

- A. Bolt equipment to floor and wall where wall exists. Where units are free standing, provide preformed steel channel or angle iron bracing to nearest wall or building structural member.
- B. Equipment anchoring shall be designed for compliance with the earthquake seismic vertical and lateral acceleration of the equipment install location. Submit structural calculations and details.

3.03 FIELD TESTING INSPECTIONS AND COMMISSIONING (ADDITIONAL REQUIREMENTS)

- A. Test all equipment after the installation has been completed, and the District's Representative has been given 10-days' notice of the proposed tests. The Contractor shall provide operating tests demonstrating that all equipment and devices operate in accordance with the Requirements of the documents.
- B. Adjustable Settings
 1. Shall be set and tested after the equipment installation is complete, for proper operation at set points, pickup, and/or drop-out points. Shall be performed by an independent Test Laboratory and trained certified Technicians actively engaged in testing and using test instruments designed and manufactured for the purpose.
 2. Provide protection device settings and test, to ensure operation and coordination as described in the time/current coordination final submittal, and in accordance with the Contract Documents.
 3. Calibrate and testing shall comply with the Equipment Manufacturer recommendations.
 4. Correct deficiencies, non-compliant equipment and retest to demonstrate compliance.
 5. Submit reports to District's Representative, six copies.
- C. Testing shall be completed in accordance with ANSI/NETA Standards.

3.04 IDENTIFICATION (ADDITIONAL REQUIREMENTS)

- A. Provide a red and white Bakelite nameplate with ½-inch high letters in each section fastened to face of dead-front plate, to read: "DANGER 480 (actual volts) VOLTS, KEEP OUT, AUTHORIZED PERSONNEL ONLY".

- B. Manufacturer shall stencil the equipment name on each device and equipment section to correspond to the identification of the Drawing.
- C. Devices mounted in equipment controlling protective devices shall be provided with name-plates indicating device controlled or monitored.

END OF SECTION 26 24 13

021821/212276

SECTION 26 50 00
LIGHTING FIXTURES

PART 1 - GENERAL

1.01 SCOPE

A. Work Included:

All labor, materials, appliances, tools, equipment necessary for and incidental to performing all operations in connection with furnishing, delivery and installation of the work of this Section, complete, as shown on the Drawings and/or specified herein. Work includes, but is not necessarily limited to the following:

1. Examine all other Specification Sections and Drawings for related work required to be included as work under Division 26.
2. General Provisions and Requirements for electrical work.

1.02 SUBMITTALS (ADDITIONAL REQUIREMENTS)

A. General

1. Submit certification letter from Manufacturers of LED drivers and power supplies, (or alternately, Manufacturer's published catalog data) stating/showing the specific power supply combination comply with Manufacturer recommendation and approval for the combined use, shown on the Drawings.
2. Provide complete Manufacturers catalog data information for each light fixture (luminaire), materials, auxiliary equipment/devices, finishes and photometrics.

B. Performance Certification

1. Submit Manufacturer's certified lamp and driver tests report data showing compliance with Contract Document.

C. Light Fixture Samples

1. If requested by the District's Representative, provide a sample of each fixture proposed as a substitution for a specified fixture. Sample fixture shall be complete with specified lamps, 3-wire grounding "SO" cord and plug for 120-volt 60Hz, AC plug-in operation. Sample fixtures shall be delivered to the District's Representative's office for review, the samples shall be picked up within 10-working days after review comments have been received; any samples left beyond this time will be discarded by the District's Representative. Decision of District's Representative regarding acceptability of any lighting fixture is final.

1.03 QUALITY ASSURANCE (ADDITIONAL REQUIREMENTS)

- A. Work and materials shall be in full accordance with the latest rules and regulations as follows. The following publications shall be included in the Contract Document Requirements. If a conflict occurs between the following publications and any other part of the Contract Documents, the Requirements describing the more restrictive provisions shall become the applicable Contract definition:

1. UL – Underwriters' Laboratory:
 - a. UL – 8750 and 1598C: Light Emitting Diode – LED Equipment for use in Lighting Products and Replacements
2. NEMA – National Electrical Manufacturers Association:
 - a. NEMA – LE4: Recessed Luminaires Ceiling Compatibility
 - b. NEMA – SSL #1, #3 and #6: Electronic Drivers for LED; LED and Incandescent Lamp Replacement
 - c. NEMA – LSD #44, #45, #49 and #51: SSL-solid state lighting
3. United States Federal Government:
 - a. FCC – Part 18: EMI and RFI emissions limitations.
 - b. EPA: Energy conservation publications and waste disposal regulations.
4. ETL and C.B.M. certified and approved.
5. Electrical installation standards, National Electrical Contractors' Association:
 - a. NEIS/NECA and IESNA – 500 Recommended Practice for: Installing indoor Commercial Lighting Systems.
 - b. NEIS/NECA and IESNA – 501: Recommended Practice for installing Exterior Lighting Systems
 - c. NEIS/NECA and IESNA - 502: Recommended Practice for installing Industrial Lighting Systems.
6. Illuminating Engineering Society – IES (IESNA):
 - a. IES – LM41: Photometric and Reporting.
 - b. IES – 587: Transient Surge Protection.
 - c. IES – LM79: Solid State Lighting (SSL) Testing and Measurement.
 - d. IES – LM80: Testing for Lifetime of LED.
7. ANSI-American National Standards Institute:
 - a. ANSI – C81
 - b. ANSI – C82
 - c. ANSI – C62.41: Transient Withstand
 - d. ANSI – C78: Lamps
8. State California Code of Regulations - Title-24: Energy Code
9. DALI – Digital Addressable Lighting Interface shall comply with latest versions of IEC-60929 and NEMA-243.

PART 2 - PRODUCTS

2.01 GENERAL

- A. Complete Fixture
 - 1. Provide light fixtures complete including lamps, ballasts, lamp holders' sockets, housings, ceiling and wall trim "rings" for each ceiling type, mounting and adapter support brackets, diffusers/lenses and outlet boxes.
 - 2. Include an allowance of \$300.00 to provide a light fixture for each lighting fixture outlet shown on Drawings without a fixture type designation.
- B. Specific Fixture Requirements and Fixture Schedule Information
 - 1. The catalog numbers included in the description of the various types of lighting fixtures shall be considered to establish the type or class of the fixture with a particular Manufacturer only. The fixture length, number of lamps and lamp types, component materials, accessories, mounting type, ceiling, wall and install adapters, operation voltage, and all other components required to fulfill the total description of the fixture based on all Drawing information, branch circuits, voltages, Specification information, and shall be included in the Contract Requirements regardless of whether or not the catalog number specifically includes these components.
 - 2. Lighting fixtures shall be the types as indicated in fixture schedule on the Drawings and as described in the Specifications.
 - 3. All fixtures of the same fixture type shall be the same Manufacturer and of identical finish and appearance, unless indicated otherwise on Drawings.
- C. Manufacturer Certification of Operation
 - 1. Lamps and lamp ballasts and power supplies (drivers) shall be recommended and certified by the respective Manufacturer(s), to be "matched" to operate correctly together, within the published characteristics, for efficacy, lamp starting, operating life hours, lumen output, power factor, power input, operating line ampere, sound intensity, and temperature.

2.02 DRIVER-POWER SUPPLIES FOR LED-SOLID STATE LAMPS

- A. General
 - 1. All power supplies, lighting fixtures assemblies and components shall be ANSI, ETL approved C.B.M. certified and UL labeled.
 - 2. Ballasts shall comply with FCC Part 18 Class-A and NEMA limits as to EMI or RFI and not interferes with normal operation of electrical or electronic data processing equipment.
 - 3. Open circuit voltage, starting voltage, crest voltage and lamp-operating voltage shall comply with Requirements of the respective Manufacturer of the installed lamps.
 - 4. Power supplies and transformers shall be for use with the specific lamps provided as part of the Contract.
 - 5. Shall be suitable for use with automatic occupancy motion sensing type switching "on-off" control systems, with multiple "on-off" cycles per hour, on a 24-hours a day basis. Operation shall be without loss of performance in operating characteristics described in the Contract Documents.

6. Fusing
 - a. Shall be independently fused on the incoming line side within the fixture compartment.
 - b. Alternately the Ballast Manufacturer may install the equipment fuse inside the ballast/power supply.
 - c. Provide a label next to ballast cover reading: "Ballast (Power Supply) is fused, check fuse prior to relamping". Provide an additional quantity of 10% spare fuses and deliver to District's Representative.
7. Ballast sound rating Class-A or better. Where sound-rating classification is not published, the ballast sound rating shall be the best of product manufactured. Ballasts, which are judged by the District's Representative to be excessively noisy, shall be removed and replaced at the Contractor's expense with low noise ballasts.
8. Electronic solid-state ballasts and power supplies shall be the product of Manufacturer that has been producing electronic ballasts/power supplies for a minimum of five consecutive years prior to the date of the Contract.
9. Provide low temperature rated ballasts and power supplies in lighting fixtures installed outdoors; in non-heated building spaces; inside walk-in refrigerators/ freezers, cold storage spaces. The minimum starting temperature rating shall be not less than zero-degrees Fahrenheit.
10. Shall be designed and supplied to operate on the incoming line voltage system circuits to which the respective light fixtures are connected.
11. Shall not contain any PCB (polychlorinated biphenyl).
12. Power factor shall be not less than 0.90, starting and operating. The input starting transient line input ampere should never exceed lamp normal operating ampere by more than 10%.
13. Ballast and power supply disconnect:
 - a. Lighting Fixture Manufacturer factory installed and prewired inside each light fixture, for lamp-ballast or lamp-driver power supply.
 - b. Shall comply with UL-2459 and CEC/NEC. Shall disconnect (load-break) energized or de-energized ballast/driver from respective line voltage circuit and dimming circuit. UL-94V-0 flame retardant.
 - c. Hot pluggable, multi-pole, insulated connectors, with strain relief and finger-safe squeeze-to-release latching function.
 - d. Suitable for available voltage and ampere dimming and non-dimming lamp-ballasts and lamp-power supplies.
14. Ballast and power supplies as manufactured by General Electric, Advance, Philips, Universal, Sylvania/Osram or equal.

2.03 LIGHT FIXTURES (LUMINAIRES)

A. General

1. Lighting fixtures shall have all parts, ballasts, sockets, support attachments, trim flanges and fittings necessary to complete and properly install the fixture at the indicated installation locations. All fixtures shall be provided with lamps of size and type specified.

2. Ceiling and/or wall surface mounted lighting fixtures shall not have any exposed chase nipples or conduit knockouts visible to view within fixture housing. Lighting fixtures mounted in continuous rows shall have chase nipples or conduit knockouts between lighting fixture housing but shall not have visible chase nipples/conduit knockouts on the visible ends of the continuous row of lighting fixtures.
3. Where fixture color is indicated to be selected by the Architect and/or District's Representative, provide two color chip samples for each color for review.
4. Recessed fixtures with attached junction box shall be provided with a junction box permanently attached to the plaster ring so that the junction box is accessible through the fixture opening when the fixture is removed. Connection between fixture and pull box shall be flexible metal conduit with not less than 16AWG "AF" or "CF" type fixture rated copper wires, high temperature wire insulation for not less than 600 volts AC. The flexible conduit shall be sufficient length, so that when the fixture is removed, the pull-box is readily accessible.
5. Recessed fixtures shall be Underwriters' Laboratory approved for recessed installation with plaster frame and attached pull box. Lamp enclosure, reflectors and finish wiring shall not be installed until plastering is completed. Exposed finish trim shall not be installed until finish painting of the adjacent surface is completed.
6. The fixture shall bear Underwriters' Laboratory label of approval for the wattage and installation indicated.
7. Light fixtures installed outdoors, in damp or wet locations shall be UL labeled for said location as "damp-location" and "wet-location" for the respective installation location.
8. Fixtures in contact with thermal/building insulation shall be UL listed and rated for direct contact installation in thermal insulation systems.
9. Lamp auxiliary support brackets shall be heat-resistant, non-dielectric. Alternatively, metal auxiliary lamp support brackets shall be electrically isolated from the fixture, to prevent glass decomposition.
10. Lighting fixtures installed in masonry and/or concrete construction. The fixture housing shall be rated for "concrete-pour" installation location.
11. Provide a permanent label inside each light fixture stating the following re-lamping information. Not less than 0.125-inch high black alphanumeric characters on white background.

"Replacement lamp(s) installed in this light fixture must comply with the following criteria:

*_: CRI	*_: Lamp Watts
*_: CCT-K	*_: Lamp Lumens

Only lamp rated *_ type lamp ballast shall be installed in this fixture."

*Insert the value required for the specific lamp required by the Contract Documents for each light fixture.

B. Lens and Diffusers

1. Acrylic plastic or Plexiglas for the light fixture diffusers or fixtures lenses shall be 100% virgin material.

2. Thickness of not less than 0.125-inch, as measured at the "THINIST" portion on the diffuser or lens. However, thickness shall be increased to sufficient construction and camber to prevent the lens and diffusers from having any noticeable sag over the entire normal life of the installation.
3. Diffusers shall be formed from cast sheet by a vacuum and/or pressure technique.
4. Lighting fixtures containing lamps with dichroic reflectors and light fixtures with non-dichroic lens/diffuser shall be rated for high temperature lamp operations resulting from lamp heat redirected (reflected) back into the fixture.

2.04 SOLID STATE LIGHTING (SSL), LIGHT EMITTING DIODES (LED) LAMPS, POWER SUPPLIES, AND LIGHT FIXTURES (ADDITIONAL REQUIREMENTS)

A. General

1. Solid State LED light source (lamps), related control equipment (driver-power supply), and luminaire (light fixture) optics for light output distribution.
2. Shall comply with the US-DOE Energy Star Program for SSL-LED. Submit documentation with Shop Drawings.
3. Shall comply with the latest revision IESNA LM-79 and LM-80. Submit documentation with Shop Drawings.
4. SSL chromaticity shall comply with latest revision NEMA and ANSI – C78.377. Submit documentation with Shop Drawings.
5. Submit with Shop Drawings two samples of each light fixture type employing SSL, with prewired 120 volt, 60Hz AC "SO" cord and plug-in cap.

B. LED Lamps

1. Lamp lumen output and overall efficiency shall be based on the LED lamps installed in specified fixture and ambient operating temperature.
2. Lamp Color Rendition Index (CRI) shall equal or exceed CRI – 80, unless noted otherwise on Drawings.
3. Lamp color output shall be 4000-degree K (\pm 100K), unless noted otherwise on Drawings.
4. CRI and lamp color temperature shall be same for all light fixtures of the same fixture type.

C. LED Power Supply (driver)

1. Combination of power supply and SSL – lamp shall be tested and certified by respective Manufacturers for performance and proper operation.
2. Provide dimming type driver where indicated on Drawings. Driver and dimming equipment shall be tested and certified by respective manufactures for performance and proper operation.

D. Self-contained LED lamp and driver, integral "Screw-Base" and/or "Pin-Connect", replacement assembly for incandescent lamps.

1. Shall be dimmable. Dimmer and lamp shall be certified by respective Manufacturers for compatible correct operation with each other.
2. Optical system and operating temperature thermal performance shall be compatible with light fixture.

3. Comply with latest revisions of NEMA LSD-49 and SSL-6.

2.05 EMERGENCY BALLAST LIGHTING AND EMERGENCY DRIVER LIGHTING

A. General

1. Self-contained emergency ballast and power supply (driver) containing batteries, battery charger, solid-state electronic control and lamp/ballast/driver operation, contained within a metal case, red finish case color.
2. UL – 924, listed Emergency Lighting and Power Equipment, for installation inside and/or attached to lighting fixtures.
3. The emergency battery supply unit(s) shall be provided inside each respective emergency light fixture by the Fixture Manufacturer.
4. Normal operating temperature range from 0-degrees Centigrade up to operating ambient temperature inside respective lighting fixture, but not less than 50-degrees Centigrade.
5. Provide a permanent label inside each emergency light fixture stating as follows, not less than 0.125-inch high black alphanumeric characters on a white background:
"Warning – this fixture provides more than one electric power source. Disconnect both normal and emergency sources including battery sources prior to opening fixture. Written permanent records documenting regular (every 30 days) emergency lighting function testing results shall be kept on file by the District."
6. UL and Manufacturer rated to supply the lamp and ballast/driver (power-supply) combination occurring in the respective light fixture, both dimming-type and non-dimming type light fixtures.
7. DALI ballasts shall be types as recommended by the DALI Lighting Control System Manufacturers for compatibility with the lighting control system and with the emergency ballast lighting system. The emergency ballast lighting system control system shall be compatible with the DALI lighting control system.
8. As manufactured by Bodine Inc. or IOTA-Engineering Inc.

B. Operation

1. Emergency mode
When external AC electrical power fails, the emergency unit shall immediately and automatically switch to emergency mode. Maintain emergency lamp(s) illumination, while operating from the internal battery/electronics during the power failure for not less than 90-minutes continuous duration.
2. Normal Mode
When AC electrical power is restored, automatically switch lamp(s) operation to external AC operation and begin battery-charging mode.
3. Battery Recharge Mode
The battery charger shall automatically fully recharge discharged batteries in less than 24-hours, and prevent overcharging of the batteries, while maintaining a "float-charge" on the batteries.

4. The emergency battery unit shall operate not less than 2-lamps in multi-lamp light fixtures and 1-lamp in single lamp light fixtures. When operating in emergency mode and battery power, the lamp lumen output of each lamp shall be not less than 40% of the lamp normal full lumen output rating of the lamp operation on normal power. The lamp-lumen output shall be 100% of the lamp normal full lumen output rating when operating in normal mode.
 5. The emergency ballast shall provide cold-strike start and hot-restrike operation of the fixture lamp(s).
 6. Periodic automatic, internal self-test, simulating normal power loss and actual operation of emergency lamps on internal battery power. Auto self-test shall occur not more than 30-day intervals. Audible and visual trouble alarm display, with manual alarm reset / silence, for problems identified by auto-test functions.
- C. Electrical Characteristics
1. Emergency equipment shall operate on the same input AC voltage as the normally "hot" branch circuit supplying the respective light fixture. Maximum line input load shall not exceed 15% more than normal fixture electrical load.
 2. The emergency equipment shall be compatible for correct operation with the specific lamp/ballast/driver combination contained in the respective light fixture.
 3. The emergency equipment shall be compatible with switched (on-off), non-switched (continuously on) and dimmer controlled lighting fixtures/circuits.
- D. Components
1. Sealed nickel cadmium batteries, maintenance-free, rated for continuous operation in high ambient temperature, with 7 to 10 year operational life expectancy.
 2. When standing on the floor below the fixture the emergency ballast test/monitor control panel shall be visible and readily accessible when the fixture is installed. The control panel shall provide:
 - a. Charging indicator visual annunciator to display the charger and battery status.
 - b. Momentary test switch/pushbutton to manually simulate power failure test.

2.06 LIGHTING STANDARDS (SUPPORT POLES, POLE MOUNTED LIGHTING FIXTURES AND LUMINAIRES)

- A. General
1. Lighting poles, pole bases, pole arms, lighting fixtures (luminaires), supports with all lighting pole attachments and anchors shall be designed and constructed to withstand not less than 100 mile per hour steady horizontal wind loading and 130 mile per hour horizontal wind gust loading, without any damage to the lighting standards.
 2. Provide tamper-resistant "hand-hole" and cover on the pole, for access into wiring terminations inside the pole. Provide ground "lug" attachment for equipment bond conductor.
 3. Provide factory applied weather protective base undercoat and final finish on all exposed and internal components. Color as indicated or as selected by District's Representative.

- B. Base Plate
 - 1. Provide a base plate at the bottom of each pole to attach and secure the pole to the pole anchor bolts. The base plate shall be permanently attached to the bottom of the pole.
- C. Anchors
 - 1. Anchor bolts shall be threaded the entire bolt length, not less than four bolts for each pole equally spaced around the pole base. Provide a minimum of two threaded nuts for each anchor bolt. Install a nut on the top and bottom sides of each base plate anchor bolt location. Not less than four threads shall be exposed after pole is installed and leveled.

PART 3 - EXECUTION

3.01 LIGHT FIXTURE INSTALLATION

- A. General
 - 1. The Contractor shall verify actual ceiling and wall construction types as defined on the Architectural Drawings and furnish all lighting fixtures with the correct mounting devices, trim rings, brackets whether or not such variations are indicated by fixture catalog number. The Contractor shall verify depth of all recessed lighting fixtures with Architectural Drawings prior to ordering fixtures. Any discrepancies that would cause recessed lighting fixtures not to fit into ceiling shall be reported to the District's Representative prior to release of order to the supplier of the fixtures.
 - 2. On acoustical tile ceilings, fixture outlets shall be accurately located in the center, at the intersection of the four corners or at the center of the joints of two tiles.
 - 3. The Contractor shall aim the exterior adjustable lighting fixtures after dark in the presence of, and at a time convenient to the District's Representative.
 - 4. Fixtures shall be ordered and furnished to operate correctly on the branch circuit voltage connected to the respective fixture as shown on the Site Plan and Floor Plan Electrical Drawings. The voltages shown on the fixture schedule are for generic fixture information only.
 - 5. Install and connect lighting fixtures to the circuits and control sequences indicated on the Drawings and to comply with respective Manufacturer's instructions/recommendations.
 - 6. Lighting fixtures in building interstitial spaces, in mechanical plumbing and electrical spaces/rooms, are shown in their approximate locations. Do not install lighting outlets or light fixtures until the mechanical, plumbing and electrical equipment/pipes/duct-work are installed; then adjust and install lighting in revised clear (non-interfering) locations to provide best even-illumination. Coordinate the locations with all other trades prior to lighting installation.
 - 7. Provide conduit and DALI Loop (Bus) communications lighting control network circuit connections, to each light fixture with DALI ballasts.
- B. Lighting fixtures installed in ceiling support grids - suspended lay-in "T-bar" and concealed spline ceilings.
 - 1. Provide two seismic clips at opposite ends of each recessed light fixture, the clip shall connect to the ceiling grid main runners and the light fixture. The light fixture with

seismic clips and ceiling grid runner connections shall resist a horizontal seismic force equal to the total weight of the light fixture assembly.

2. Each light fixture weighing 40-pounds or less and where the respective ceiling grid system is "heavy duty" type, shall be suspended directly from the ceiling grid or shall be suspended independent of the ceiling grid support system as approved by the AHJ. Each light fixture weighing more than 40-pounds or where the ceiling grid system is not a "heavy duty" type shall be supported independent of the ceiling grid and independent of ceiling grid support system.
3. Each light fixture supported independent of the ceiling grid system shall be supported with a minimum of four taut independent support wires, one wire at each fixture corner.
4. Each light fixture supported directly from the ceiling grid or ceiling grid support system shall be additionally connected with a minimum of two independent slack safety support wires. One wire at each opposite diagonal fixture corner. Each 3-foot by 3-foot and larger light fixture shall be supported in the same manner, except provide a minimum of four independent slack safety wires, one at each fixture corner.
5. Light fixtures surface mounted to a suspended ceiling shall be installed with a 1½-inch steel – "C" channel which spans across and above a minimum of two parallel main ceiling grid "runners" and concealed above the ceiling. Each channel or angle member shall be provided with a minimum of two threaded studs for attaching to the fixture housing through the lay-in ceiling tile. Two steel "C" channel members shall be installed for each 4-foot (or smaller) fixture. Install the channels within 6-inches of each end of the light fixture to span a minimum of two ceiling grid parallel main runners. Provide two seismic clips connecting the ceiling grid main runners to each steel – "C" channel. Provide a not less than two taut independent support wires connecting to each channel. Bolt the light fixtures to the threaded studs on the channels or angles, to support the light fixture tight to the ceiling surface.

C. Fixture Supports

1. The support wires for light fixture support shall be 12-gauge steel (minimum). The wires including their building and light fixture attachments shall provide support capacity of not less than four times the weight of the light fixture assembly. Provide additional light fixture support wires and building anchors to meet these Requirements, as part of the Contract. The support wires shall be anchored to the building structural elements above the ceiling.
2. Pendant mounting fixtures shall be supplied with swivel hangers. Fixtures shall swing in any direction a minimum of 45 degrees of gravity, position. Fixtures shall have special stem lengths to give the mounting height indicated on the Drawings. Stem to be single continuous piece without coupling, and to be finished the same color as the canopy and the fixture, unless otherwise noted. The Contractor shall check all lock nuts and set screws to rigidly secure the swivel socket to the stem, and the stem to the outlet box.

Fixtures shall be plumb and vertical. Where obstructions occur restricting 45-degrees free-swing of fixtures, the fixtures shall be "guy" wired to prevent fixtures from striking obstructions. The District's Representative shall approve method of guying. Swinging fixtures shall have an additional safety hanger cable attached to the structure and the fixture at each support, with the capacity of supporting four times the vertical weight of the light fixture assembly.

3. Suspended fixtures weighing in excess of 40-pounds shall be supported independently of the fixture outlet box. Provide "aircraft" (minimum 12 gauge) steel hanger cable for suspended fixtures route cable concealed or in pendant where possible. Each cable attachments shall support four times the weight of the fixture assembly. Securely attach the cable to the building structure.
 4. Surface mounted fixtures installed on drywall or plaster ceilings and weighing less than 40-pounds may be supported from outlet box. Provide structural supports above drywall or plaster ceilings for installation of fixtures weighing more than 40-pounds and secure fixture to structural supports. The use of toggle bolts is prohibited.
- D. Recessed Lighting Fixtures - Fire Rated Building Surfaces
1. Lighting fixtures recessed in ceiling or wall which has a fire resistive rating of 1-hour or more shall be enclosed in a fully enclosed backbox (except over fixture lens/diffuser). The material used to fabricate the "enclosed backbox" shall have a fire rating equal to that of the respective ceiling or wall.
 2. The space from the fixture to the box enclosure shall be a minimum of 3-inches.
 3. The backbox shall be concealed behind the fire rated ceiling and wall finish surface. The light fixture shall be provided with lamp ballast rated for (normal light output) operation in a "high" ambient temperature.

3.02 LENS AND DIFFUSERS

Lens, diffusers, internal reflectors shall be completely cleaned of all dust, dirt and fingerprints after the installation of the light fixtures and lamps, and after all trades have completed work and prior to occupancy of the facility by the District.

3.03 COMMISSIONING LIGHTING FIXTURES (ADDITIONAL REQUIREMENTS)

- A. General
1. Verify correct lighting control configurations and operation in each room.
 2. Simulate normal source power failure by "opening" (turn off) building main service disconnect and verify connections and operation of each emergency lighting fixture.
 3. Confirm "EXIT" sign directional arrows are visible in each "EXIT" sign.
 4. Verify light fixture support-hangers, ceiling grid clips and seismic restraints comply with the Contract Documents.
 5. Remove protective shipping/installation shields on fixtures. Verify fixtures and lamps are clean and free of construction debris. Clean light fixtures found to be contaminated or dirty.
 6. Setup, program, and function test lighting control systems to perform each of the indicated control functions, area/room zones and sequences.
 7. Provide "aiming", directional adjustment of light fixtures, both indoor and outdoor. Aiming shall comply with Manufacturer's aiming diagrams, and as directed by District's Representative.
- B. Sample spot-check in each room the following lighting fixture information:
1. Lamp type and performance data.
 2. Ballast type and performance data.

3. Combined lamp/ballast certification of performance and compatibility by respective Manufacturer.
4. Verify instructional signage is placed inside each lighting fixture in compliance with Contract Documents.

END OF SECTION 26 50 00
021821/212276

SECTION 27 21 00
ELECTRONIC NETWORK SYSTEMS INFRASTRUCTURE

PART 1 - GENERAL

1.01 SCOPE

- A. Work Included: All labor, materials, appliances, tools, equipment necessary for and incidental to performing all operations in connection with furnishing, delivery and installation of the work of this Section, complete, as shown on the Drawings and/or specified herein. Work includes, but is not necessarily limited to the following:
 - 1. Examine all other Specifications Sections and Drawings for related work required to be included as work under Division 26.
 - 2. General Provisions and Requirements for electrical work.
- B. Provide Electronic Network Systems Infrastructure for the following systems:
 - 1. Computer Data Networks
 - 2. Telephone and Intercom Voice Communications
 - 3. Other special systems described in the Contract Documents.

1.02 SUBMITTALS (ADDITIONAL REQUIREMENTS)

- A. Drawings Submittals
 - 1. Drawings shall be submitted on reproducible sepias and AutoCAD® Version 2.2 (or later revision) data files on CD/DVD-ROM disk, WINDOWS®-XP/VISTA or Version-7 format.
 - 2. Submit redrawn Building Floor Plan for each building area, same scale as the Contract Drawing.
 - 3. Plans shall show walls, doors, windows, furniture, infrastructure, outlets and network systems equipment locations. Show point-to-point interconnecting cables, pathways, conduit, conduit sizes, and circuit types, along with circuit identification names, numbers, and quantities between all components.
 - 4. Provide Scaled Elevation Drawings of each equipment rack, terminal blocks, terminal backboard, and terminal room/closet showing location and arrangement of each equipment component, outlet and cable training provisions, with estimated weight of each complete assembly.
 - 5. Submit block wiring diagrams showing major system components, outlets, equipment racks, terminal blocks, signal loss with interconnecting circuit conductors, splices, portable patch cords and connectors. Riser type diagram shall be provided if the building has more than one floor level, with information shown on riser diagram corresponding for each respective floor.
- B. Submit Manufacturer's standard catalog data for each component. The submittal shall be arranged in the order of the Specification and shall list the Specification paragraph number, the name, the proposed model and Manufacturer for each item as well as a reference indicating the specific piece of data which can be easily located in the brochure. The Manufacturer's data sheets shall be marked to indicate the specific item being proposed in cases where the sheet covers several types or sizes of items. The data sheet shall completely

describe the proposed item. Where modification to the equipment is necessary to meet the operational Requirements of the Contract Documents, the brochure shall include complete Mechanical and Electrical Shop Drawings, detailing the modification. The brochure shall include a listing of the outlet rough-in Requirements for every device and equipment item. The applicable symbol which illustrates that rough-in item on the Job Plans shall be drawn on the proposal, opposite the description of the rough-in to facilitate locating the data by Field Personnel. Submit elevation and dimensional information.

C. Performance Calculation:

1. Provide engineered calculations showing the Passive Cable System Signal Attenuation losses of the proposed installed system. The intent is not to require calculations for every system segment, port and outlet. The intent is to require engineered calculations for proposed typical worst-case port to port, head end to farthest distance outlet and patch port to outlet signal attenuations.
2. Provide calculations for a minimum of 25-complete channel/circuit paths. The calculations shall include attenuation insertion losses for each system component including individually itemized cable-fiber/wire; outlet, termination, connector, electronic component (if any), coupler and patch cord along the entire path from the head end equipment to the end use outlet.
3. The calculations shall serve as the basis for verifying the system performance with the system testing specified in the Contract Documents.

D. Provide proposed nameplate and outlet identification/color coding system. Indicate proposed identification naming sequence and methods, itemized for review.

E. Submit Manufacturer certified test reports showing test documentation for the proposed material that the material meets or exceeds the Performance Standards defined in the Contract Documents. The testing and results shall reflect worst case performance based on a minimum of ten samples. Tests shall be certified by a Nationally Recognized Independent Test Lab (i.e., ETL, UL, etc.). The Manufacturer shall certify in writing the material has been manufactured and tested to comply with the Requirements defined in the Contract Documents.

F. Submit three samples of each of the following, fully assembled with 24-inches of cable type connected:

1. Copper wire outlet and connector, with each type of specified inserts.
2. Copper cables and patch cords, each type.
3. Fiber optic cables and patch cord each type.
4. Mechanical splice - fiber optic.
5. Fusion splice - fiber optic.
6. Fiber optic outlet and connector each type.
7. Fiber optic cable connector each type of termination, with interconnection coupler.
8. Patch panel each type.
9. Coverplate each type.

1.03 APPLICABLE STANDARDS

- A. The Equipment shall be UL listed, labeled, and approved for the application shown in the Contract Documents.
- B. The Complete system material, equipment, testing, installation and workmanship shall comply with the Mandatory Requirements and the Guideline/Recommendation Requirements of the following latest published version, supplements, latest revision including Addendums and TSB. Both the Mandatory and Advisory Criteria shall be included as Requirements of the Contract Documents:
 - 1. TIA-526 Optical Power and loss measurements – multimode and single mode fiber.
 - 2. ANSI/TIA/EIA-568C Commercial Building Telecommunications Standards.
 - 3. ANSI/TIA/EIA-569B Commercial Building Standards for Telecommunications Pathways.
 - 4. ANSI/TIA/EIA-570A Residential Telecommunications Standard.
 - 5. ANSI/TIA/EIA-598B Optical Fiber Cabling Color-coding.
 - 6. ANSI/TIA/EIA-606A Administrative Standard for Commercial Telecommunications Infrastructure.
 - 7. ANSI/TIA/EJA-607 Commercial Buildings Grounding and Bonding Requirements for Telecommunications.
 - 8. FCC – FYU/FT6.
 - 9. ISO/IEC-11801
 - 10. National Electrical Code (NEC) and California Electrical Code (CEC) including Articles 770 and 800 with ETL verified testing and local Code Jurisdictions.
 - 11. NECA/NEIS, National Electrical Contractors Association, National Electrical Installation Standards:
 - a. 301 – Standard for Installation and Testing for Fiber Optic.
 - b. 568 – Standard for Installing Building Telecommunications Bonding and Grounding.
 - c. 607 – Telecommunications
 - 12. Manufacturer's recommendations for the respective equipment.
- C. The Entire Completed Electronic Network Systems Infrastructure shall be tested and provide electronic data/network and telephone/voice multi-channel communications latest Revisions, Standards and Addendums, for the following protocols:
 - 1. IEEE 802.3/ETHERNET:
 - a. 10Mbps 10Base-T, 100Mbps 100Base-Tx, and 1000Mbps (1Gbps) 1000Base-Tx for copper wire; 100-meter communications pathway distance.
 - b. 10Mbps 10Base-F1, 100Mbps 100Base-FX, 1000Mbps 1000Base-Lx-Sx and 10,000-Mbps (10Gbps) for fiber optics; 550-meter communications pathway distance, OM4 Standard for multimode and OS2 for single mode.
 - c. IEEE-802.3 for Power Over Ethernet-Plus (POE Plus).
 - 2. FDDI – Distributed data interface on fiber or copper wire, 100Mbps.
 - 3. 100VG – AnyLAN
 - 4. EIA Serial and Bi-directional RS-232 and RS-485m including Star-Hub repeaters

5. ANSI – TPPMD 55Mbps, 155Mbps and 622Mbps Asynchronous Transfer Mode - ATM.
- D. The Complete Telephone/Voice Infrastructure System shall be suitable for the telephone/voice analog and digital communications and VoIP protocols. The system shall be compatible with the telephone/voice equipment installed as part of the Contract.
- E. Installation of all Infrastructure Equipment, devices, splices, terminations, cables, outlets, etc. shall comply with Manufacturer's recommendations.

1.04 EQUIPMENT QUALIFICATIONS

A. Equipment

1. The Supplier of the equipment shall be the factory authorized Distributor and Service Facility for the brands of equipment and material provided.
2. Network systems infrastructure equipment and materials shall all be the product of one of the individual same Manufacturers as follows. Typical unless specifically described otherwise:
Corning Siecor to match existing equipment on site.

B. Installation Certification

1. Work and material for cables, cable terminations, outlets and related components for infrastructure systems shall be performed by Certified Installers. The Installer shall be certified by the respective Product Manufacturers.
2. The Manufacturers of the indicated work and material shall provide an Installer education/training and certification program for the supplied products.
3. The Installers performing the Contract Work for the indicated products shall have attended and successfully completed each of the respective Manufacturer's installation training education programs for the specified products.
4. Submit six copies of the Manufacturer's certifications for each Installer performing the work. The submittal shall be approved by the Owner's Representative prior to initiating any related Contract Work.
5. Contract material installed, and work performed by Installers not complying with these Requirements shall be removed. Removal of work and material not in compliance with these Requirements shall be done at the Contractor's expense, without any additional cost to the Contract and without any additional Contract completion due date extensions. New material and work required to replace the non-complying removed work and material shall be provided at the Contractor's expense, without any additional cost to the Contract and without any additional Contract completion due date extensions.

C. Extended Material and Performance Warranties

1. In addition to the Warranty Requirements described elsewhere in the Contract Documents, provide the following extended material and performance warranties. The warranty period shall be for not less than 15-years from the Contract Notice of Completion.
2. Warranty Scope includes materials and performance for network cables and terminations, network workstation plug-in outlets, and patch panel plug-in outlets, cable splices and connectors.

3. Repair or replace the defective material with new material at the project premise, to comply with the Performance Standards outlined in the Contract Documents during the warranty period.
4. Submit seven copies of proposed warranty statements, with Shop Drawing submittals.

1.05 ABBREVIATIONS

<u>Abbreviation</u>	<u>Terminology</u>
ACR	Attenuation to Cross Talk
AHJ	Authority Having Jurisdiction
Backbone	Interconnections between MDF and IDF locations
dB	Decibel
dBm	Decibel referenced to a milliwatt.
Demarc	Demarcation location where operational control change or ownership change occurs.
ft.	Feet
GHz	Gigahertz
Horizontal Connection, and/or Horizontal wiring	Circuit Interconnections between individual workstation outlet location to respective IDF or MDF equipment rack patch panel.
IDF	Intermediate distribution frame (horizontal or vertical cross connect) for an individual building area/floor.
KM	Kilometer-IKM
kpsi	1000 pounds per square inch
m	Meter = 39.37 inches
Mbps	Megabits per second
MDF	Main distribution frame (central/main cross connect) for multi-building site or for a single individual building.
Mhz	Megahertz
micron	Micrometer
mm	Millimeter = 10^{-3} meter
NEXT	Near end cross talk
nm	Nanometer = 10^{-9} meter
pF	Picofarad = 10^{-12} farad
RTDE	Equipment rack mounts fiber optic termination distribution enclosure, with fiber optic patch panel
RMSE	Equipment rack mount fiber optic enclosure, splice only, (without patch panel)
STP	Shielded twisted pairs copper wire.
ScTP	Shield Screened twisted pairs copper wire.
Trunking-Cable	Individually insulated twisted pair copper wire cable, consisting of 24-pair or more of conductors inside a common cable jacket. Terminate and connect to common terminal-block location at each end of the trunking-cable.
um	Micrometer = 10^{-6} meter
USE	Universal splice enclosure.
UTP	Unshielded twisted pairs copper wire
VoIP	Voice communications over internet protocol
WGNA	Wide Band Gigabit Networking Alliance

Workstation or Workstation location	Spaces remote from the MDF/IDF terminal room/closet, where occupant interacts with the electronic systems infrastructure equipment connection device.
WMIC	Wall mounts fiber optic cable interface cabinet.

1.06 MATERIALS AND METHODS

- A. Material and Labor not complying with the Contract Documents shall be removed by the Contractor from the project site. Material and labor complying with the Contract Documents shall be provided.
- B. All the cost to remove deficient work and material, provide work and material complying with the Contract Documents and the direct, indirect, incidental damages and Contract delays resulting from complying with these Requirements shall be the sole responsibility of the Contractor and shall be included in the bid price.
- C. System Performance Requirements
 1. The work, performance and type of materials provided as part of the Contract shall comply with the following ANSI/TIA/EIA-568C and related Standards for all Electronics Network Systems Infrastructure work and materials described in the Specifications and shown the Drawings:
 - a. Computer/data network systems: Category-6.
 - b. Telephone/intercom voice systems: Category-6.
 2. The Electronic Network Systems Infrastructure system shall be based on “star-topology” for MDF to IDF backbone connections and workstation outlet to MDF/IDF horizontal connections.

PART 2 - PRODUCTS

2.01 FIBER OPTICS CABLES

- A. General
 1. Operating temperature range 20-degrees centigrade through +60 degrees centigrade. Cables shall be flame retarding.
 2. Electronic network systems infrastructure cables that are not installed inside conduit raceways. Electronic network systems infrastructure cables that are installed in concealed spaces including plenums and non-plenums; access floors, ceiling spaces, walls, floor, etc., and/or installed without continuous raceways. The cable insulation and jacket shall be listed and labeled “limited combustible cable” (LC or LCC) and shall comply with the latest published revision of all of the following additional Requirements.
 - a. Limited combustible “FHC-25/50” per UL-2424.
 - b. NEC/CEC; CMP, additional listing/labeling where the install location is an environmental air plenum, “FHC-25/50-CMP”.
 - c. NFPA-90A; ceiling cavity plenums, wall cavity spaces and raised floor cavity plenums, limited-combustible.
 - d. NFPA-5000; defines combustible material including wire and cable.
 - e. NFPA-75 computer rooms and electronic equipment room.

- f. NFPA-13; spaces containing “limited combustable loading”.
 - g. Shall qualify as 100% recyclable materials disposal.
3. All fibers in a multi-fiber cable shall be fully operational within the performance characteristics specified prior to and after the cable is installed. The use of spare fibers in the cable to compensate for defective fibers is not permitted. Defective cables shall be removed and replaced with fully functional cables at no additional cost to the Contract.
 4. Cables shall be UL listed, complying with National Electrical Code, ETL Tested and Certified to comply with Specified Requirements. ANSI/TIA/EIA-568C including related Standards, Amendments and TSB.
 5. Each fiber shall be individually identified with factory color coding or factory imprinted label. The outer cable jacket shall be imprinted with date, Manufacturer's model and catalog number, along with agency listing identification.
 6. Fiber optic cable shall be a product of the same Manufacturer, including portable patch cables.
 7. The outer cable jacket shall be imprinted with date, Manufacturer’s model and catalog number and AHJ listing identification.
 8. Cables installed in raceways or conduits below grade, through in-grade manholes or pull-boxes shall be rated for installation in water/wet locations.
 9. Cables containing less than six fiber strands shall be provided with a color-coded outer jacket (red or orange).
 10. Multimode (50/125)
 - a. 50/125-fiber optic cables optical fibers, graded index multimode optical glass fibers, 50.0-micron fiber core and 125-micron fiber cladding, 0.2 numerical apertures. Optical fibers shall be 100kpsi proof tested, with maximum 0.7-micron flaw size for dual operation at 850nm and 1300nm wavelengths.
 - b. Minimum bandwidth:

@ 850nm-wavelength	500Mhz per KM length
@ 1300nm-wavelength	500Mhz per KM length
 - c. Maximum attenuation:

@ 850nm-wavelength	3.4dB @ 1 KM length
@ 1300nm-wavelength	1.4dB @ 1 KM length
 11. Single mode:
 - a. Fiber optic cables optical fibers, (8.3/125) single mode optical glass fibers, 8.3-micron core fiber and 125-micron fiber cladding, 0.11 numerical apertures. Optical fibers shall be 100kpsi proof tested, with maximum 0.7-micron flaw size. For operation at 1310nm and 1550nm wave lengths.
 - b. Maximum attenuation:

@ 1310nm- wavelength	0.5dB @ 1 KM length
@ 1550nm - wavelength	0.4dB @ 1 KM length
 - c. Maximum dispersion

@ 1310nm - wavelength	2.8ps/nm KM length
@ 1550nm - wavelength	18.0ps/nm KM length

B. Loose Tube Gel-filled Cables

1. Multiple, loose tube buffer tubes, gel filled. Each buffer tube shall contain the same quantity of optical fibers, but not more than twelve optical fibers in each buffer tube.
2. Buffer tubes shall be cabled around a central dielectric strength member. The central strength member shall be centered along the length of the cable.
3. Aramid yarn, non-optical, strength fibers shall extend continuously along the length of the cable.
4. The cable interstitial spaces shall be flooded to inhibit water migration, with non-flammable water blocking gel.
5. Each optical fiber shall be individually UV cured acrylate coated, 250-micron diameter coating over fiber cladding.
6. A seamless black polyethylene outer layer jacket shall envelope the entire cable.
7. The cable shall be fungus resistant, UV resistant, and moisture resistant for installation indoors with or without an enclosed raceway and outdoors in underground enclosed raceway/conduit and manholes/pullboxes continuously flooded with water.

C. Indoor/Outdoor Cables

1. The cable shall be fungus resistant, UV resistant, and moisture resistant for installation indoors with or without an enclosed raceway and outdoors in underground enclosed raceway/conduit and manholes/pullboxes continuously flooded with water, and in conduits exposed to the sun.
2. Each optical fiber shall be primary coated with 500-micron uniform acrylate tight buffered and with elastomeric uniform 900-micron diameter tight buffered, secondary coating. Aramid yarn strength member elements shall be tensioned and symmetrically and uniformly distributed around the fibers, along the length of the cable.
3. An overall cable jacket uniformly extruded directly around and mechanically interlocked with the optical fibers/strength members. The extruded jacket shall form internal helical cusped ridges that interlock with the optical fibers and strength members. The interlocking jacket shall not allow cable fibers to move axially within the cable jacket.
4. Cables containing more than twenty-four optical fibers shall be constructed with sub-cable fiber bundles. Each sub-cable bundle shall contain equal quantities of optical fibers, with a separate PVC jacket around each sub-cable. Sub-cable and sub-cable jacket construction shall match the overall Cable Requirements and Jacket Requirements.
5. The cable shall be UL listed and comply with NEC and CEC and NFPA Requirements for each installation location shown in the Contract Documents. ETL tested and certified to comply with or exceed Specified Requirements.
 - a. NEC/CEC - OFNR (Vertical Riser Type Locations) OFNP (UL FHC-25/50 LC Plenum Type Locations and locations (where not continuously enclosed inside conduits for entire cable length)).
 - b. NEC/CEC - OFNG (where continuously enclosed inside conduits for entire cable length).

D. Tight Buffered Cables

1. Each optical fiber shall be coated, 900-micron diameter uniform coating, with uniform tight buffering over the coating, uniform dielectric strength member surrounding the buffering coating and an overall jacket around each optical fiber assembly.
2. Individual multiple optical fiber assemblies shall be symmetrically arranged around a central dielectric strength member. The central strength member shall be centered along the length of the cable.
3. A dielectric strength member shall surround the fiber assemblies.
4. An outer dielectric jacket shall envelope the entire cable.
5. The cable shall be UL listed and comply with NEC and CEC and NFPA Requirements for each installation location shown in the Contract Documents. ETL tested and certified to comply with or exceed specified Requirements.
 - a. CEC - OFNP (UL FHC-25/50 LC Plenum type locations and locations where not continuously enclosed inside conduits for entire cable length).

2.02 COPPER WIRE CABLES (TWISTED PAIRS)

A. General

1. Conductors shall be copper wire, individually insulated and color-coded, with multiple conductors arranged in twisted pairs.
2. An overall non-conductive jacket shall encase the copper wires and any shielding (where shielding is specified) shall also be encased by the jacket.
3. Cables shall be UL listed, complying with NEC National Electrical Code, National Fire Protection Agency and NFPA Requirements for each installation location shown. ETL tested and certified to comply with or exceed Specified Requirements.
 - a. CEC – MPP/CMP (Plenum type locations and locations where not continuously enclosed inside conduit).
 - b. CEC – MPR/CMR (Vertical riser type locations).
 - c. ANSI/TIA/EIA-568C – Including related Standards, Amendments and TSB.
4. Electronic network systems infrastructure cables that are not installed inside conduit raceways. Electronic network systems infrastructure cables that are installed in concealed spaces including plenums and non-plenums; access floors, ceiling spaces, walls, floor, etc., and/or installed without continuous raceways. The cable insulation and jacket shall be listed and labeled “limited combustible cable” (LC or LCC) and shall comply with the latest published revision of all the following Additional Requirements.
 - a. Limited combustible “FHC-25/50” per UL-2424.
 - b. NEC/CEC; CMP, additional listing/labeling where the install location is an environmental air plenum, “FHC-25/50-CMP”.
 - c. NFPA-90A; ceiling cavity plenums, wall cavity spaces and raised floor cavity plenums, limited-combustible.
 - d. NFPA-5000; defines combustible material including wire and cable.
 - e. NFPA-75 computer rooms and electronic equipment room.
 - f. NFPA-13; spaces containing “limited combustible loading”.

- g. Shall qualify as 100% recyclable materials disposal.
 - 5. Cables installed in air plenums, air-handling spaces and cables installed without raceway or conduit shall also be UL listed and labeled for installation in air plenums.
 - 6. The outer cable jacket shall be imprinted with date, Manufacturer's model and catalog number and agency (AHJ) listing identification.
 - 7. Cables installed in raceways or conduits below grade, through in-grade manholes and pullboxes shall be rated for installation in water/wet locations.
 - 8. Copper wire Electronic Network Systems Infrastructure cable shall be a product of the same Manufacturer, including portable patch cables.
 - 9. The outer jacket of cables with less than 9-pair of conductors shall be color coded. The jacket color shall be different for each system type; multimedia; telephone/voice; computer/data network; and fiber cable jackets.
 - 10. 300-volt RMS insulation material for each data conductor shall be the same material; shall be the same electrical characteristics and shall be the same dielectric constant, for all data conductors contained within the respective common cable jacket, along the entire installed length of the cable. Data cables employing differing insulation materials for individual data conductors contained within a common cable jacket are not acceptable and shall not be provided.
 - 11. Propagation and "Skew" Rate
 - a. Skew rate (nominal velocity of propagation delay) between any twisted pair in a combination of 4-twisted pair conductors grouped in the same cable, shall not exceed 35 nano seconds between any wire pair contained in the conductor group, and as required by the cable Category rating, over a cable length of 328-feet (100 meters), for all frequencies up to the cable maximum frequency rating.
 - b. Nominal velocity of propagation, 70% of the speed of light.
 - 12. Copper wire cables with more than 25-twisted pairs of conductors shall be constructed with 25-pair binder groups of conductors. The cable binder groups shall be enclosed in colored binders and assembled to form a single cable. The twisted pair/binder groups shall be enclosed with multi-layer dielectric protective sheaths underneath a cable jacket enclosing the entire cable assembly. A corrugated metal 100% shield shall be provided under the cable jacket enclosing all conductors.
- B. Category-5E Computer/Data Enhanced Cables for Trunking Cable - UTP**
- 1. Category-5E cables shall be tested and shall pass ANSI/TIA/EIA test recommendations for Category-5E Trunking Cables.
 - 2. Operational characteristics:
 - a. Wire size: 24AWG solid copper (24AWG stranded copper for portable patch cables)
 - b. Quantity of twisted pairs as indicated but in no case less than 25-twisted pairs
 - c. Impedance 100 OHM \pm 15%, 3-100MHz
 - d. Maximum Signal Attenuation per 300 feet 6.3dB @ 1MHz
 (100 meters) 13dB @ 4MHz
18dB @ 8MHz
20dB @ 10MHz
25dB @ 16MHz

28dB @ 20MHz
 32dB @ 25MHz
 36dB @ 31.25MHz
 52dB @ 62.5MHz
 67dB @ 100MHz

- e. Mutual Maximum capacitance of Any Pair 14pf/feet
- f. Worst Pair "NEXT" Loss Per/328-feet (100 meters)
 - 62dB @ 1Mhz
 - 53dB @ 4Mhz
 - 48dB @ 8Mhz
 - 47dB @ 10Mhz
 - 44dB @ 16Mhz
 - 42dB @ 20Mhz
 - 41dB @ 25Mhz
 - 40dB @ 31.25Mhz
 - 35dB @ 62.5Mhz
 - 32dB @ 100Mhz

C. Category-6 Computer/Data Cables – UTP

1. Category-6 cables shall be tested and shall pass the ANSI/TIA/EIA test recommendations for Category-6.

2. Operation Characteristics:

- a. Wire size - 23AWG solid copper (23AWG stranded copper for portable patch cables)
- b. Quantity of twisted pairs - As indicated but in no case less than 4-twisted pairs
- c. Impedance 100 OHM ± 15%, 1-250Mhz
- d. Maximum Signal Attenuation Per 328-feet (100 meters)

2.0dB @ 1Mhz
 3.8dB @ 4Mhz
 5.3dB @ 8Mhz
 6.0dB @ 10Mhz
 7.6dB @ 16Mhz
 8.5dB @ 20Mhz
 9.5dB @ 25Mhz
 10.7dB @ 31.25Mhz
 15.4dB @ 62.5Mhz
 19.8dB @ 100Mhz
 29.0dB @ 200Mhz
 32.8dB @ 250Mhz

- e. Mutual Maximum Capacitance of Any Pair 5.0nF/100m
- f. Worst Pair "NEXT" Loss Per/328-feet (100 meters)
 - 74.3dB @ 1Mhz
 - 65.3dB @ 4Mhz
 - 60.8dB @ 8Mhz
 - 59.3dB @ 10Mhz
 - 56.2dB @ 16Mhz
 - 54.8dB @ 20Mhz
 - 53.3dB @ 25Mhz

51.9dB @ 31.25Mhz
47.4dB @ 62.5Mhz
44.3dB @ 100Mhz
39.8dB @ 200Mhz
38.3dB @ 250Mhz

2.03 FIBER OPTIC FIBER SPLICES

A. General

1. Fiber optic cable splices shall be UL listed, complying with National Electrical Code, ETL tested and certified to comply with or exceed specified Requirements, ANSI/TIA/EIA-568B including related Standards, Amendments and TSB.
2. Fiber optic splices shall be the products of the same Manufacturer.

B. Mechanical Splice

1. Mechanically splice each fiber with a splice suitable for use with the type of fiber optic fibers. Re-enterable and reusable splice. Splice shall be recommended as compatible with the optical fibers by the Manufacturer. Splice shall not require the use of adhesives. Splice shall provide integral strain relief.
2. Performance Requirements after installation:
 - a. Operating temperature range minus 20-degrees centigrade through plus 60-degrees centigrade.
 - b. Loss variation over temperature range, 0.05dB or less at specified wave lengths.
 - c. Insertion loss, 0.3dB or less at specified cable wave lengths.
 - d. Reflection (return loss), -40dB at specified cable wave lengths.

C. Fusion Splicing

1. Fusion splicing shall be performed with equipment providing the following features:
 - a. Cleaving and cleaning optical fiber.
 - b. Integral splice optimization verification system with local injection and detection.
 - c. Projection screen optics and fiber core alignment system.
 - d. Fiber cleaning/stripping.
 - e. Cleaning fiber ends and fusing of fiber together with an electric arc.
2. Fusion splice insertion loss as measured at the completion of the splice shall be less than 0.1dB at specified cable wave lengths.

2.04 FIBER OPTIC FIBER CONNECTORS AND INTERCONNECTION COUPLERS

A. General

1. The connectors and interconnection couplers shall be compatible, maintain the same Performance Category rating and be compatible with the corresponding fiber-optic cable type attached to the connectors.
2. Fiber optic cable connectors and interconnection couplers shall be UL listed, complying with National Electrical Code, ETL tested and certified to comply with or exceed Specified Requirements. Connectors and couplers shall comply with ANSI/TIA/EIA-568C, related

Standards, Amendments, TSB, and Fiber Optic Connector Intermate Standard (FOCIS) documentation.

3. Fiber optic connectors and couplers shall be the product of the same Manufacturer.
 4. Shall be UL listed and comply with UL94V-0.
 5. Color code connectors for fiber optic cables to match the respective fiber optic strand/jacket color.
- B. Multimode Fiber Optic Fiber Connectors
1. LC – Small Form Factor (SFF) termination connector:
 - a. Ceramic oxide 1.25mm ferrule. Mechanical durability not less than 500-mating cycles. Insertion loss of mated connector shall be less than 0.3dB at specified wavelengths.
 - b. Strain relief boot, long boot type unless indicated otherwise, short or angled boot type to match the connector installation application. Provide duct cover cap for each connector.
 - c. Locking type to automatically align mating fibers in the fiber cable and prevent accidental rotation and pullout.
- C. Fiber Optic Fiber Interconnection Couplers
1. Interconnection couplers shall be “like-to-like” compatible and shall provide "plug-in" coupling of two fiber optic cable connectors terminated with fiber optic fibers front-to-rear "in-line" together. The coupler shall provide interlocking, automatic optical self-alignment of two mating fiber optic connectors.
 2. The centerline to centerline spacing of the interconnection couplers shall allow removal and insertion of portable patch cords, fiber cable connectors for both “single” and “duplex” type fiber adapter connectors without interfering with adjacent connectors.
 3. Patch panel mounted interconnections couplers shall be factory pre-mounted to a modular nominal 0.09-inch-thick metal panel, couplers aligned and anchored on the plate.
 - a. The metal panel shall be predrilled for Standard EIA mounting in high-density 19-inches wide metal patch panel frames.
 4. Interconnection couplers in workstation outlets shall be installed in outlet boxes with cover plates.
 5. Provide removable dust caps for the front side of each coupler.

2.05 COPPER WIRE OUTLET CONNECTORS

A. General

1. Connectors shall comply with FCC part 68 Subpart F for gold plating.
2. Connectors shall be UL listed and shall comply with UL94V-0.
3. Provide a removable blank dust cover for each plug-in outlet insert. The dust cover shall protect the insert from contamination until a workstation or patch cord is "plugged" into the outlet.

4. Copper wire outlet connectors shall be color coded to distinguish telephone/voice separately from computer/data. The outlet coverplate shall be engraved to identify telephone/voice, computer/data and other infrastructure outlets separately.
 5. Copper wire outlet connectors shall be UL listed, complying with National Electrical Code, ETL tested and certified to comply with or exceed Specified Requirements, ANSI/TIA/EIA-568C including related Standards, Amendments and TSB.
 6. Copper wire outlet connectors shall be the product of the same Manufacturer.
- B. Universal Outlet Connector (for twisted pair Copper Wire Premise/Workstation Wiring and copper wire patch panels).
1. General
 - a. Connections for twisted pairs copper conductors shall provide a universal outlet connector between the building premise copper wire, and plug-in workstation locations. Patch panel/equipment plug-in connectors. The connector components shall assemble with "snap-in" spring loaded retainers to prevent dislocation during insertion or removal of external plug-in devices.
 - b. The contacts shall be gold plated with a 250-insertion/withdrawal cycle rating.
 - c. Unless specifically noted otherwise the universal outlet connector shall comply with ANSI/TIA/EIA-568C, related Standards, Amendments, and TSB.
 - d. Operational characteristics shall match or exceed and shall be compatible with the respective twisted pair's cable.
 - e. Each universal outlet connector shall consist of three major components.
 - 1) Universal edge connector assembly.
 - 2) Plug-in adapter inserts.
 - 3) Connector housing.
 - f. Provide snap-in blank removable insert covers for connector installed without plug-in adapter inserts.
 2. Universal edge connector:
 - a. Insulated assembly shall connect to the premise copper wire. The connectors shall be multiple plug type connector contacts, one contact (total of eight contacts) for each individual premise wire connection interconnected to the individual wire terminations.
 - b. Connector shall provide insertion of individual insulated copper wire, gas tight, 110-style punch down/displacement termination, for 22-26AWG insulated premise wire.
 - c. The edge connector assembly shall provide termination of eight separate wire conductors, twisted or untwisted pairs, solid or stranded, shielded or unshielded, with color codes and numbered identification of each contact. Integral cable/conductor strain relief to prevent pullout of terminated premise wire conductors.
 3. Plug-in adapter inserts:
 - a. Plug-in adapter inserts shall be internally factory connected to the universal edge connector assembly to adapt the universal connector to the specific outlet type configuration (i.e., "RJ" style computer/data, telephone/voice, (multimedia) modular jacks, etc.)

- b. Inserts shall be certified to match premise wire type connected to the universal edge connector.
 - c. Inserts shall provide correct pin-to-pin connections, electrical and mechanical matching characteristics for the specific equipment connected to the respective outlet.
 - d. Inserts for different infrastructures shall be color coded with different colors from each other, for system identifications.
 - e. Plug-in adapters insert type:
 - 1) Computer/data network systems:
 - a) ANSI/TIA/EIA-568C, female modular jack 8-position/contact "RJ-45" style, keystone, "snap-in" mounting.
 - 2) Telephone/intercom voice systems:
 - a) ANSI/TIA/EIA-568C female modular jack 8-position/contact RJ-45, keystone, "snap-in" mounting.
4. Connector housing:
- a. Connector housing shall contain the universal edge connector assembly and the plug-in adapter inserts in a rigid assembly. Connector housing shall provide integral cable strain relief for the premise wiring connection.
 - b. The connector housing shall mount to a metal panel, metal device cover plate or plastic device cover plate with spring loaded snap-in retainers. Nominal depth of connector housing behind the mounting panel and/or device cover plate shall not exceed 1.625 inches including premise wiring termination depth Requirements.

2.06 FIBER OPTIC FIBER DISTRIBUTION ENCLOSURES

A. General

- 1. Fiber optic fiber distribution enclosures shall be UL listed, complying with National Electrical Code, ETL tested and certified to comply with or exceed Specified Requirements, ANSI/TIA/EIA-568C including related Standards, Amendments and TSB.
- 2. Fiber optic fiber distribution enclosures shall be the product of the same Manufacturer.

B. Equipment Rack Mount Fiber Optic Termination Distribution Enclosure - RTDE

- 1. The RTDE enclosure shall mount in an EIA Standard 19-inches wide enclosed or open frame equipment rack assembly. The RTDE enclosure shall be metal, painted finish, Manufacturers standard color.
- 2. The RTDE shall provide the following self-contained functions internal to the RTDE assembly.
 - a. Fiber cable termination.
 - b. Fiber cable "pig-tail" splicing.
 - c. Fiber cable patch panel.
 - d. Fiber cable management, training and strain relief.
 - e. Individual fiber and patching port identification numbers, color-coding of incoming trunk and out-going distribution fiber ports.

- f. Plug-in fiber optic interconnection couplers for port-to-port patching with portable fiber optic patch cords.
- 3. Fiber splice drawers:
 - a. Horizontal sliding metal drawers adjustable to approximately 30-degree angle when fully open, and removable for easy access. Each drawer shall contain two fiber optic splice trays with tray holders.
 - b. Drawers shall stack vertically one above the other in the RTDE and allow sufficient slack in all fiber cables for removal of the drawer and splice trays.
 - c. Provide one sliding drawer and two splice tray assemblies for each group (24-individual fibers or fewer fibers per group) of fiber optic fibers terminated in the equipment rack, but in no case provide not fewer than two sliding drawers with splice tray assemblies in each RTDE.
- 4. Fiber cable patch panel
 - a. Metal panel shall provide a patch port for each fiber consisting of metal panel mounted fiber optic interconnection couplers for each fiber optic fiber indicated to be terminated at the RTDE.
 - b. The fiber optic fiber interconnection coupler shall be provided to match and be compatible with the fiber cable connectors. Quantity shall match quantity of terminated fibers, unless indicated otherwise on the equipment rack schedules.
 - c. Nominal panel thickness 0.09 inches.
 - d. Provide a minimum of sixteen unused spaces for additional couplers in the patch panel.
- 5. Nominal height of the RTDE shall not be exceeded, as follows:

<u>Quantity of Patch Ports</u>	<u>Quantity of Splice Drawers</u>	<u>Nominal Height</u>
24	2	11 inches
48	2	11 inches
72	3	14 inches
144	6	28 inches

- C. Equipment rack mount fiber optic, splice only (for use only where fiber patch panel is not required) enclosure - RMSE
 - 1. The RMSE enclosure shall mount in an EIA standard 19-inches wide enclosed or open frame rack assembly. The enclosure shall be metal, painted finish, Manufacturer's standard color.
 - 2. The RMSE shall provide the following self-contained functions internal to the RMSE assembly:
 - a. Fiber cable splicing for "thru splicing" of fiber optic cables where the cables do not terminate in the equipment rack.
 - b. Fiber cable management, training and strain relief.
 - 3. Fiber splice drawers
 - a. Horizontal sliding metal drawers adjustable to approximately 30-degree angle when fully open and removable for easy access. Each drawer shall contain two fiber optic splice trays with splice tray holders.

- b. Drawers shall stack vertically one above the other in the RMSE and allow sufficient slack in all fiber cables for removal of the drawers and splice trays.
 - c. Provide one sliding drawer and two fiber optic splice tray assemblies for each group (24-individual fibers or fewer fibers per group) for fibers optic fiber routed through but not terminated in the equipment rack, but in any condition provide not fewer than two sliding drawers with splice tray assemblies in each RMSE.
4. Nominal height of the RMSE shall not be exceeds, as follows:

<u>Quantity of Thru Splices</u>	<u>Quantity of Splice Drawers</u>	<u>Nominal Height</u>
24	2	4 inches
48	2	4 inches
72	4	8 inches
96	4	8 inches

2.07 COPPER WIRE PATCH PANELS

A. General

- 1. Copper wire patch panels shall be UL listed, complying with National Electrical Code, ETL tested and certified to comply with or exceed Specified Requirements, ANSI/TIA/EIA-568C including related Standards, Amendments and TSB.
- 2. Copper wire patch panels shall be the product of the same Manufacturer.

B. Equipment Rack Mounted Patch Panel

- 1. Standard EIA 19-inches wide metal panel, Manufacturers standard color. Pre-punched for copper wire outlet connectors. Panel shall mount on an EIA standard 19-inches wide enclosed or open frame equipment rack assembly. Nominal 24-copper wire outlet connectors in a horizontal row, quantity of rows as required for total quantity of connectors. Provide not less than two spare empty rows for future copper wire outlet connectors.
- 2. The patch panel shall provide the following self-contained functions.
 - a. Copper wire cable termination including conductor/shield termination and strain relief.
 - b. Plug-in copper wire outlet connectors for port-to-port patching with copper wire portable patch cords.

- 3. Patch panel height shall be based on the quantity of copper wire outlet connectors described plus the specified space for future outlets and shall not exceed the following dimension height:

<u>Outlet Quantity</u>	<u>Nominal Patch Panel Height</u>
48-patch ports in each patch panel	Shall not exceed 3.5-inches for each 48-port panel.

- 4. Horizontally mounted, cable support metal bracket shall be provided for 48-outlet/connector groupings between fiber and copper wire. The brackets shall be bolted to the equipment rack located at the backside of the patch panel; the brackets shall support and provide strain relief for each incoming copper wire cable connecting to the patch panel left-right cable entrance pathway.
- 5. The copper wire connector installed in the patch panel shall be the same configuration, Manufacturer and type as the corresponding copper wire connector provided in the

remote workstation outlet locations connecting to the respective patch panel outlet, unless indicated otherwise.

2.08 EQUIPMENT RACK

A. General

1. An equipment grounding bus, nominal 19-inches long, UL labeled as a ground terminal bus, shall be provided on each equipment rack. The ground bus shall be bolted to the rack main metal frame member with 1-inch standoff non-insulating bolts. Provide a minimum of ten drilled and tapped bolt holes in the ground bus with ground lug bolts, for connection of equipment grounding conductors to the ground bus, size to accept ground conductors #14-#4AWG.
2. Vertically mounted, cable management metal rings (aluminum or stainless steel) shall be provided full height, continuously along the front and rear of each vertical rail of the equipment rack. The rings shall be bolted to the equipment rack. The rings shall train and dress portable patch cords connecting between outlet connectors located in the equipment rack or in adjacent equipment racks.
3. Provide horizontal cable management panels with multiple cable training rings on each panel (not less than five rings for each panel). Management panels (for up to 24-outlet grouping) nominal 19-inches wide by 1.75-inch high by 3-inches deep and/or (for up to 48 outlet groupings) 3.5-inches high by 3-inches deep, for EIA rack installation. Rings shall provide horizontal routing and support by grouping portable patch cords connecting between patch ports in the same equipment rack or adjacent racks. Patch cords shall be grouped and bundled with "Velcro" tie wraps and shall not overlap patch fields or rack mounted equipment. The panels shall be installed on both the front and rear of the equipment racks, mounted both above and below horizontally between groups of patch ports as follows:
 - a. One cable management panel (front and rear of rack) for each group of 48-fiber optic outlet patch ports adjacent to copper wire patch panel.
4. The entire rack assembly including any support arms shall comply with seismic earthquake structural standards at the install location.
 - a. The assembly shall provide support for the weight of the equipment installed on the rack, but in no case less than 500 pounds of equipment, plus the weight of the rack and connecting cables. A 2.0 times safety factor shall be included in the equipment rack assembly structural design.
 - b. Mini-equipment racks shall be rated for not less than 200 pounds of equipment, plus a 2.0 times safety factor shall be included in the mini-equipment rack.
5. Provide Surge Protection Device with RF Suppressor (SPD) and Power Distribution Unit (PDU). 120-volt 1-phase, 20-amp 60Hz AC plug horizontal strip, mounted in each equipment rack. Each unit shall contain not less than eight "plug-ins" on the rear of the SPD and not less than two plug-ins on the front of the SPD protected outlet plugs.
 - a. Provide two SPD/PDU units in each equipment rack, to supply "dual-corded" equipment.
6. Provide pre-drilled mounting holes the entire length of equipment vertical mounting frames, EIA-310D 19-inches (nominal) wide standard spacing for indicated equipment.

Racks shall provide 17.75-inches (nominal) equipment horizontal mounting space between vertical rails.

7. Provide a copper ground – bus for equipment bonding, in each equipment pack.
8. Equipment racks shall be Manufacturer’s standard rust inhibitor primer. Manufacturer’s standard color-finish paint over primer, unless noted otherwise.

B. Mini-Equipment Racks Sectional – Surface Wall Mount (Indoor Locations Only)

1. The mini-equipment rack shall be fully metal enclosed, tamper resistant, wall surface mounted and multiple section construction. The rack shall consist of three sections; a fixed wall mounting pan; a hinged center section and a hinged door. The rack shall provide a minimum of 30-inches clear internal depth for mounting of equipment inside the rack. Provide brackets inside the pan for stress relief, training/lacing, support of cables.
2. The mini equipment racks nominal dimensions shall be as follows:
 - a. Overall depth 33-inches.
 - b. Overall width 22-inches.
 - c. 24-inches minimum over all height, for termination of up to a quantity of 144-copper wire workstation patch panel outlets and up to a quantity of eighteen individual fiber strands, combined into a mini-equipment rack.
 - d. 30-inches minimum overall height, for termination of up to a quantity of 192-copper wire workstation patch panel outlets and up to a quantity of eighteen individual fiber strands combined, into the mini-equipment rack.
 - e. 48-inches minimum overall height, for termination of up to quantity of 288-copper wire workstation patch panel outlets and up to a quantity of eighteen individual fiber strands combined, into the mini-equipment rack.
3. Fixed wall, surface mounted pan section, nominal 3-inches pan depth, metal enclosed on all sides and back, open front; shall anchor the rack to the wall; provide support for the hinged center rack section and provide knockouts for side/top/bottom and rear conduit/raceway entrances.
4. Center section, metal enclosed on all sides, open front and rear, nominal 18-inches depth, full height and width hinged attachments to the pan-section, to provide hinged 90 degrees open-close operation of the center section on the pan and allow access to the front and rear of equipment and terminations mounted inside the center section. Two internal vertical, front mounted, pre-drilled equipment mounting frame rails. Self-locking with release latch accessible from inside cabinet.
5. Front access door section, metal, full height and width hinged 90 degree open-close operation attached to the center section. The door shall allow for nominal 3-inches minimum of interior projections extending from the front face of the internally mounted equipment located behind the front access door when the access door is in the closed position. Smoke/gray impact resistant, tamper resistant see-through windows in the door front. Key-locking front of door exterior access.
6. Minimum 16-gauge metal, fully welded construction; Manufacturer’s standard rust inhibitor “prime” base coating, with “finish” color black or as selected by Architect. The equipment racks shall provide support for the weight of the equipment installed in the

rack, but in no case less than 200 pounds of equipment plus the weight of the rack and connecting cables.

7. Provide two 120-volt 60Hz AC motor direct driven air ventilation, "muffin" style, nominal 4 inches square, exhaust air fans. Flush mount fans in the top of each equipment rack. The fans shall be low speed, low noise type with wire guards to prevent accident contact with the fan blades. The fan motor shall be high impedance, self-protecting type motors. Provide "SO" cord with plug caps to connect from the fans to the 120-volt plug-strip inside the equipment rack.
8. Provide cooling air intake louvers with removable air filters and air filter holder, mounted in the bottom of the rack. The louver shall be protected with internal screening to prevent the intentional insertion of foreign objects into the housing.
9. The mini-equipment rack shall be easily convertible in the field, to allow for "left" or "right" center section and/or door section hinge operation. Provide a minimum of two key-locks on each hinged section to prevent unauthorized access into the unit. Provide gasketing on all "mating" cabinet interfaces to insure proper cooling airflow through the air filters.
10. Mini-equipment racks as manufactured by Hoffman/Pentair; or Middle Atlantic Products Inc.; or B-Line.

C. Plug Strip Surge Protection Device (SPD)

1. General

- a. Self-contained unit combining plug-in SPD strip and power distribution unit PDU. Rated 20 amp, nominal 120 volt +10%, 60Hz, AC, 2400 watts full continuous load or 20 amp, nominal 208-volt $\pm 10\%$, 60Hz, AC, 4800-watts full continuous load. Note: 120-volt or 208-volt ratings as indicated on the Drawings.
- b. Internal 20-amp resettable overload protection circuit breaker. Red illuminated on-off switch. Nine foot, 12AWG three conductor grounded, high abuse heavy duty jacketed AC, line cord with cap. Multi-outlet receptacles, suitable for use with the following types of plug-in loads; data processing equipment, audio/video equipment, test instruments, medical equipment, photo graphic equipment and "switching type" power supplies.
- c. Protected outlet shall be 120-volt NEMA 5-15R 15-amp or 20-amp 120-volt NEMA 5-20R AC 60Hz receptacles; or for 208-volt, NEMA 6-15R 15 amp or 208-volt NEMA 6-20R 20-amp receptacles as applicable for connected equipment loads. Provide not less than eight protected outlet plugs on each unit. Each individual or group of two receptacles (duplex) shall be connected to separate protected load isolated filter banks.
- d. Each duplex shall be isolated from the other output receptacles, minimum isolation of 25dB at 1MHz line to line, line to neutral, line to ground and neutral to ground.
- e. Non-blocking plug-in locations/orientation, for plug-in self-contained "power-brick", equipment power supplies.
- f. As manufactured by Libert, or TRIPP LITE.

2. Operation

Self-contained RFI and EMF shielded housing with mounting slots for temporary mounting of the unit. Protected outlet receptacles shall supply over current protected and filtered, electrical line voltage power to the connected equipment. Line noise RFI and EMI interference filtering suppression, surge protection device and spike protection shall occur in all three modes of operation line to ground, line to neutral and neutral to ground rated as follows:

- a. 13,000-amp, 210 joules (watt-seconds) peak withstands capacity.
- b. Transient response time less than 5-nano seconds.
- c. 140-volt AC RMS initiate spikes suppression 330 volt maximum let through.
- d. RFI and EMI Suppression-Provide spectrum analysis test dB attenuation reports showing RFI filtering over specified frequencies.
- e. Diagnostic indicator lights located on the SPD housing shall provide alarm alert for each of the following conditions:
 - 1) Loss of AC power.
 - 2) Damage, malfunction in the SPD suppression circuits.
 - 3) Improper AC electrical outlet wiring.
- f. Self-contained metering and communications
 - 1) Ampere-meter demand load meter to monitor plug-in demand load.
 - 2) Digital Fast Ethernet LAN RJ-45 communications port for Ethernet SNMP network monitoring of electrical status. Multi-user site wide software license, compatible with PC-computer and IP-WEB HTTP protocols.
- g. Standards Testing, Listing and Certification Compliance:
 - 1) IEEE 587A and B compliance.
 - 2) UL 1449 transient voltage surge suppressers.
 - 3) UL 1363 temporary power taps.
 - 4) UL 1283 electromagnetic interference filters.

3. Rack Mounted SPD/PDU

- a. SPD/PDU units installed in equipment racks shall comply with all of the same Performance Requirements including as follows.
 - 1) EIA/TIA – Equipment rack mount style (19-inches or 24-inches as applicable).
 - 2) Minimum of two front mounted outlets and not less than six rear mounted outlets.
 - 3) Position in each equipment rack as directed by Owner’s Representative.

D. Power Distribution Unit (PDU)

1. General

- a. Self-contained unit combining main circuit breaker, multiple plug-in individual circuit breaker branch protection load receptacles, PDU metering status monitoring and network communication. All PDU components self-contained in a NEMA-1 metal enclosure.

- b. Non-blocking plug-in locations oriented for plug-in self-contained “power-brick” equipment supplies.
 - c. Standards Testing
 - 1) UL 60950-1 Information Technology Equipment.
 - 2) CAN/CSA-C22.2 No.60950-1-03 Information Technology Equipment.
 - 3) FCC, Title 47, Part 15 Subpart B for Class B operation as defined by ANSI Standard C63.4
 - 4) ROHS Complaint
 - 5) ISTA Procedure 1A and 2A
 - d. Provide two PDU units in each equipment rack, to supply two SPD units in each equipment rack.
 - e. Shall be a product of the same Manufacturer as the SPD unit. As manufactured by Liebert, or TRIPP LITE.
2. System Description
- a. Remote monitoring and/or control capabilities for power distribution at each load/ equipment rack level. For data/network equipment line voltage plug-in and SPD line voltage plug-in electrical distribution.
 - b. PDU shall meter and monitor electrical attributes of an individual Rack PDU, including real-time remote and local display of monitoring of aggregate and branch electrical parameters (status, thresholds, alarms) including voltage, ampere, and kW. Rack equipment PDU and Branch load monitoring and control.
 - c. Self-contained metering and communications
 - 1) Local display ampere-meter demand load meter to monitor plug-in demand load and total PDU load.
 - 2) Digital Fast Ethernet LAN RJ-45 communications port for Ethernet SNMP and IP network monitoring of electrical status. Multi-user site-wide software license, compatible with PC-computer and IP-WEB HTTP protocols.
 - 3) Provide network array-interface for connection of multiple PDU units positioned in the same location.
 - d. Nine-foot input power (heavy duty high abuse) cord with appropriate conductors and input NEMA plug-in connection. Provide input overload protection with Hydraulic-Magnetic main input circuit breaker. Provide load output NEMA plug-in branch connection with overload circuit breaker protection for each load receptacle.
 - e. Equipment rack mounting horizontal position form factor.
3. Electrical Power ratings shall be as follows and as additionally indicated on Drawings. Refer to Drawings for twist-lock versus straight-blade configurations.
- a. Single main input circuit breaker 30-amp 208/120 volt 1-phase 4-wire grounded 60Hz AC.

- b. Branch load circuit breakers with a single plug-in receptacles for each load circuit breaker. Balance loads on each circuit phase.
 - 1) Three 20 amp 1-pole circuit breaker and three 120-volt NEMA 5-20R receptacles. Also provide matching cap.
 - 2) Two 20 amp 2-pole circuit breaker and two 208-volt NEMA 14-20R receptacle. Also provide matching cap.
 - 3) One 30 amp 2-pole circuit breaker and one 208-volt NEMA 14-30R receptacle. Also provide matching cap.
 - 4) Additional circuits and receptacles as indicated on Drawings.
- 4. PDU units installed in equipment racks shall comply with all of the same Performance Requirements including:
 - a. EIA/TIA – equipment racks horizontal mount style (19-inch or 24-inch) as applicable.
 - b. Position in each equipment rack as directed by Owner’s Representative.
- 5. Provide two Category-6 4-pair UTP 15-foot-long portable patch cable connects, PDU to respective network patch panel port.

2.09 WALL MOUNT FIBER OPTIC CABLE INTERFACE CABINET (WMIC)

A. General

- 1. Metal (14 gauge) enclosure, with full height hinged metal door. Door shall be pad-lockable. Nominal size 12-inches deep by 18-inches wide by 36-inches high. Enclosure shall mount directly on the wall.
- 2. WMIC shall be UL listed, complying with National Electrical Code, ETL tested and certified to comply with or exceed Specified Requirements, ANSI/TIA/EIA-568C including related Standards, Amendments and TSB.
- 3. Interface cabinets shall be the product of the same Manufacturer.

B. The WMIC shall provide the following self-contained functions internal to the WMIC enclosure.

- 1. Fiber cable splicing for "through splicing" of non-UL listed fiber optic cables, where the cables do not terminate in the building.
- 2. Fiber cable management, training, and strain relief.
- 3. Transition from non-UL flame spread listed fiber optic cable, to UL flame spread listed fiber optic cables where the cables terminate in the building.

C. Cable routing rings shall organize optic fibers in a 360-degree loop inside the WMIC housing and provide cable strain relief.

D. Fiber Optic Splice Trays

- 1. Provide fiber optic cable splice trays.
- 2. Tray holders shall provide mounting and support for each splice tray.
- 3. Provide two splice trays for each group (twenty-four or less fibers per group) fiber optic fibers routed through the WMIC, but in no case provide not less than four splice trays in the WMIC.

2.10 SPLICE TRAY FIBER OPTIC FIBERS

A. General

1. Trays shall be suitable for installation in USE, WMIC, RMSE and RTDE enclosures.
2. The trays shall be the product of the same Manufacturer as the respective enclosures.
3. Splice trays shall be UL listed, complying with National Electrical Code, ETL tested and certified to comply with or exceed Specified Requirements, ANSI/TIA/EIA-568C including related Standards, Amendments and TSB.

B. Splice Trays

1. A metal or nonmetal splice tray shall provide space for up to twenty-four splices of individual fiber cable single mode and multimode optical fibers. The trays shall provide individual splice holder inserts for each splice to adapt the tray for mechanical or fusion splices, with or without splice sleeves.
2. The tray shall incorporate integral fiber tie down clamps, fiber routing rings, provide strain relief and two full 360-degree fiber loops around the tray perimeter with sufficient slack fiber for removal of the tray for access and splicing of the fiber cable. The tray shall insure the minimum bending radius of the optical fibers is not violated.
3. Provide a removable clear plastic tray top cover for each tray, to protect and isolate the fibers.

2.11 WORKSTATION OUTLETS

A. General

1. Engrave outlet cover plates with the port number corresponding to the port number at the respective terminal block, patch panel, or head-end equipment.
2. The outlet cover plates shall be factory pre-punched and formed to accommodate the installed outlet connector with attachment screws.
3. Workstation outlets shall be UL listed, complying with National Electrical Code, ETL tested and certified to comply with or exceed Specified Requirements, ANSI/TIA/EIA-568C including related Standards, Amendments and TSB.
4. Workstation outlets shall be the product of the same Manufacturer.

B. Computer/Data Workstation Copper Wire Outlets

1. The outlets shall be the same configuration and type as the corresponding connector provided in the copper wire patch panel outlet, unless noted otherwise.
2. ANSI/TIA/EIA-568C, and related Standards, Addendums and TSB.
3. The copper wire outlet connectors for twisted pair wire connections in computer workstation outlets shall be universal outlet connector RJ-45 type.
 - a. RJ-45 type

C. Telephone/Voice Handset Twisted Pair Wire Connection Workstation Outlets

1. The copper wire outlet connectors provided in telephone/voice handset outlets, shall be universal outlet connector type, unless noted otherwise, ANSI/TIA/EIA-568C and related Standards, Addendums and TSB.
 - a. RJ-45 type

D. Outlet Boxes

1. Wall mounted

- a. Flush or surface wall mounted outlet box as indicated on the Drawings, but in no case less than 4.69 inches by 4.69-inches by 2.125-inches deep.
- b. Two gang wide extension ring for outlet box to extend outlet flush with finish surface, or as noted on the Drawings.
- c. Two gang wide cover plate or as noted on the Drawings.

E. Multi-outlet Raceway Workstation Outlets

1. Copper wire outlet:

- a. Where copper wire connection is indicated for the workstation outlet, provide one universal outlet connector for each outlet.
- b. Each universal outlet connector shall be single connector housing type.
- c. Provide a rectangular cutout and metal device plate in the raceway sized to Outlet Manufacturer's recommendations. The workstation copper wire outlet shall mount a modular faceplate kit with outlet bezel and faceplate sized to match the workstation outlet.
- d. Offset the location of outlets for electronic network systems 6 inches in the raceway from other outlets, do not "stack" outlets one above the other in the raceway.

2.12 PORTABLE PATCH CORDS

A. General

1. Provide portable patch cords for all copper wire and fiber optic cable infrastructure outlets:
 - a. For interconnecting electronic network equipment to electronic network workstation outlets.
 - b. For interconnecting equipment rack patch panel outlet patch locations with each other.
 - c. For interconnecting patch panel outlets equipment racks mounted hubs, switches, routers etc.
2. Patch cords shall be factory assembled tested and certified with factory terminated plugs at each end. Field terminated portable patch cords shall not be permitted. Terminated plugs shall incorporate integral bending radius limiting molded "boots" and strain relief. Patch cord assemblies shall be rated for "heavy duty", "high-abuse" service.
3. Patch cords shall be UL listed, complying with National Electrical Code, ETL tested and certified to comply with or exceed Specified Requirements. ANSI/EIA/T1A-568C, related Standards, Addendums and TSB.
 - a. NEC and CEC - OFNG/OFN for fiber optic portable patch cords.
 - b. NEC and CEC - MPP/CMP/CMR/CMG/MPG for copper wire twisted pair portable patch cords.
4. Patch cords which are not installed shall be delivered to the Owner in cardboard boxes. The patch cords shall be neatly bundled and tied together. Mark each box with quantity and type of cords contained in the box.

5. Patch cords shall comply with the same cable communication Category-6 Performance Requirements, Protocol Requirements and Testing Requirements as the respective infrastructure cables and outlets to which the patch cords are intended to be connected (plug-in).
 6. The outer jacket of each portable patch cord shall be imprinted with Manufacturer's model, date, and catalog number, and AHJ listing identification.
 7. Provide a permanent, visible, factory applied identification number on each end of each patch cord. The identification number shall be the same on each end. However, the numbers shall sequentially on each patch cord and shall be unique and not duplicated on other patch cords. Permanently apply the identification numbers on jacket or connector.
 8. Portable patch cord shall be manufactured by Gruber Communications Products; no other Portable Patch Cable Manufacturer is acceptable to the Owner.
- B. Copper Wire Portable Patch Cords
1. Computer/data and telephone/voice patch cords, general:
 - a. "Male" eight positions modular "RJ" male style jacks install on each end of the patch cord cable. The jack shall be provided with a rear "bubble boot" to prevent the plug tab from snagging when pulled backwards through adjacent wiring.
 - b. Patch cord cable shall be UTP to match premise wiring, 4-pair twisted, stranded copper individually insulated wires, thermoplastic jacket over all the wires and shield.
 - c. Connectors shall comply with FCC 68.5 and Part 68 Subpart F.
 - d. Connectors UL listed and shall comply with UL-94V-O.
 - e. Contacts gold plated with not less than a 750 insertion/withdraw cycle rating.
 - f. Provide RJ-45 connector feed patch cord cables for both computer/data and telephone/voice copper wire patch cords.
 2. Portable patch cord quantities and lengths for connecting port-to-port equipment rack patch panels. Typical for computer/data and telephone/voice.
 - a. Patch cord quantity: Provide one complete patch cord assembly for each copper wire workstation outlet port in the equipment rack patch panels. One-to-one straight through pin-to-pin wiring. Additional spare not required by Owner. Cable jacket color shall be blue:
 - b. Provide the following lengths of copper wire patch cables for copper wire equipment rack patch panel outlets.
 - 1) 1 foot long - 95% of total quantity
 - 2) 4 feet long - 5% of total quantity
 3. Portable patch cord quantities and lengths for connection from workstations equipment to equipment workstation outlets. Typical for computer/data and telephone/voice.
 - a. Patch cord quantity: Provide one complete patch cord assembly for each copper wire workstation outlet located remote from the equipment rack patch panels. Provide additional spare patch cords, quantity equal to 15% of the total quantity of patch cords provided for each copper wire workstation outlets. Cable jacket color shall be blue.

- 1) Network outlet segments the pin-to-pin patch cord wiring configuration and jacks shall be compatible with the network interface card, and workstation outlet.
 - 2) Telephone outlet segments the pin-to-pin patch cord wiring configuration and jacks shall be compatible with the telephone interface protocol and workstation outlet.
- b. Provide the following lengths of copper wire patch cables for copper wire workstation outlets. The patch cords shall provide internal cross-over wiring to conform the pin-to-pin connections required between the workstation outlet and the communications protocol interface card installed in the respective workstation equipment:
- 1) 8 feet long - 30% of total quantity
 - 2) 15 feet long - 70% of total quantity
4. The Owner will furnish additional portable patch cords for modification, installation, and connection of patch panels to trunking cables by the Contractor.
- C. Fiber Optic Portable Patch Cords
1. General
 - a. Provide fiber optic fiber connectors installed on each fiber end of the patch cord cable. The fiber optic portable patch cord shall be "duplex" with two fiber strands type, for each patch cable. The "LC" connector shall be mechanically and optical compatible with the respective connecting patch panel couplers and network work equipment couplers.
 - b. The entire patch cord assembly total insertion loss shall be less than 1.0dB at the specified operating wavelengths.
 - c. Operating temperature range 30 degrees centigrade through +60 degrees centigrade. Cables shall be flame retarding.
 - d. Each fiber shall be individually identified with factory color coding and factory imprinted label. The outer cable jacket shall be imprinted with date, Manufacturer's model, and catalog number, along with agency listing identification. The cable jacket color shall be yellow standard color.
 - e. All fiber optic patch cord cable shall be a product of the same Manufacturer.
 - f. Optical fiber shall be coated, 900-micron diameter uniform coating, with uniform tight buffering over the coating, uniform dielectric strength member surrounding the buffering coating and an overall jacket around each optical fiber assembly.
 - g. A dielectric strength member shall surround the fiber assemblies.
 - h. An outer dielectric jacket shall envelope the entire cable.
 - i. The cable shall be UL listed and comply with CEC and NFPA Requirements for each installation location shown in the Contract Documents.
 - j. Patch cord quantity and length
 - 1) Patch cord quantity: Provide one complete patch cord assembly for each fiber optic patch panel outlet in the equipment rack.

- 2) Provide one complete patch cord assembly for each computer workstation fiber optic outlet remote from the patch panel.
 - 3) Provide additional spare patch cords, quantity equal to 25% of the total quantity of patch cords provided.
- k. Provide the following quantities and lengths of fiber optic patch cords.
- 1) 3 feet long - 40% of total
 - 2) 6 feet long - 30% of total
 - 3) 10 feet long - 30% of total
2. Multimode patch cords
- a. Patch cord cable shall be fiber optic cable with equal or better characteristics as the premise fiber optic cables.
3. Single mode patch cords:
- a. Patch cord cable shall be fiber optic cables with single mode optical glass fibers, and with equal or better characteristics as the premise fiber optic cables.

2.13 TRUNKING CABLE TERMINAL BLOCKS

A. General

1. Terminal blocks Type 110, shall consist of wiring blocks, connecting blocks, direct wire/ patch cord cross connection and designation strips. Arrange in unitized, modular, vertical mounting sections, for Trunking Cable Category – 5E.
2. Completely 100% front accessible for cross connections, terminating conductors, training, and fanning of cables. Rear access for any reason shall not be permitted.
3. Terminal blocks shall be UL listed, complying with National Electrical Code, ETL tested and certified to comply with or exceed Specified Requirements. Terminal blocks and connections performance shall comply with ANSI/TIA/EIA-568C and related Standards, Addendums and TSB and shall comply with and be listed under UL 1863. Category rating shall match the cables connecting to the patch panel.
4. The trunking cable terminal blocks shall provide cross connection of four pair premise copper wiring outlets to multiple copper wire trunking cable feeder cables and external free-standing equipment.
5. Each full height vertical section terminal block assembly shall terminate a minimum of 300 pairs (including specified spares for future construction phases) of trunking cable conductors, plus associated cross connection wiring and patch cords in a nominal 20-inches wide space. Provide multiple vertical sections of terminal block assemblies adjacent to each other, total quantity as required for quantity of conductor pairs and feeder cable pairs shown on the Drawings and Requirements, plus specified spares.
6. Each terminal block vertical section assembly shall provide not less than 15% of spare unused conductor pair terminals for future connections.
7. Provide a common ground bus in each terminal block section with a minimum of six ground conductor termination positions, #10AWG through #6AWG.
8. Terminal blocks shall be the product of the same Manufacturer.

B. Wiring Blocks

1. One piece molded, die-electric thermoplastic blocks. The wiring block shall support and secure all the components of the terminal block assembly and provide cable/conductor training and organization.
2. Fire retardant complying with UL 94V-0.
3. Standoff type support legs for mounting to backboard with pre-drilled anchor holes.
4. Non-conductive electrically quiet front assembly.
5. Horizontal index strip rows, for termination of not less than 25-conductor pairs on each row. Color-coded and marked in groups of four pairs or five pairs to match connecting cables.
6. Removable retainers at the ends of each horizontal connecting block index strip row, shall support cross connect wires at corner turns.
7. Distribution rings shall retain cross connect wire horizontal routing between terminations.
8. A full width, horizontal trough between each 100-pair wiring block shall provide a path for patch cord training and retention.

C. Connecting Blocks

1. Connecting blocks shall provide gas tight conductor electrical connections with conductor insulation displacement punch down slots, for insertion onto the telephone/voice wiring block index strips.
2. Connecting blocks shall electrically connect one-to-one between each conductor terminated at the wiring block index strips, and each cross connect/patch cord conductor terminated/connected to the opposite front side of the connecting block.
3. Both sides of the connecting blocks shall terminate pairs of UTP 22-26AWG stranded or solid copper wire individually insulated conductors. The front side of the connecting blocks shall also provide "plug-in" connections for portable patch cords, 110-style "plug-in" connectors.
4. Connection blocks shall be 4-pair insulated copper conductor type.
5. Provide insulated, removable termination caps for each connector block.
6. Connector blocks shall be marked to indicate tip and ring conductors and to indicate polarization.

D. Designation Strips

1. Designation strips shall provide retention of interchangeable labels. The labels shall show circuit identification of each terminated conductor pair.
2. The designation strips shall mount on the center and outside positions of the wiring block.

E. Trunking Cable Cross Connection

1. The cross-circuit connection between incoming and outgoing feeder cables and outlet wiring shall be provided in the terminal block assembly.

2. The cross-connection wiring shall terminate incoming and outgoing circuit conductors between respective connecting blocks.
 - a. Direct connect cross connection shall provide internally wired one-to-one conductor twisted pair cross connection. Cross connection of each 4-pair outlet cable to corresponding 4-pairs of the device feeder cable and cross connection of feeder-to-feeder trunking cables, as applicable.
 - b. Patch panel cross connect, 110-terminal connector style, plug-in. One, two, three or four twisted pair, 110-connector type portable patch cords will be furnished by the Owner for Contractor modification, installs, and connect.

PART 3 - EXECUTION

3.01 NETWORK CABLE TESTING AND COMMISSIONING (ADDITIONAL REQUIREMENTS)

A. General

1. In addition to the testing recommended in ANSI/TIA/EIA-568C and related Standards, Amendments and TSB. End-to-End test 100% of all individual optical fiber, individual copper wire conductors, each outlet and each connector in all terminated and un-terminated cables, portable patch cord, outlets and patch panels provided in the Contract, shall be tested after installation as a complete channel pathway installation, splicing outlets and termination is completed, including the following tests.
 - a. Each circuit insertion loss.
 - b. Each circuit NEXT (Pair-to-Pair) loss.
 - c. Each circuit NEXT loss (Power Sum) PS.
 - d. Each circuit ELFEXT loss (Pair-to-Pair).
 - e. Each circuit ELFEXT loss ((Pair-to-Pair).
 - f. Each circuit ELFEXT loss (Power Sum) PS.
 - g. Each circuit return loss (RL).
 - h. Each circuit propagation delay.
 - i. Each circuit propagation delay-skew.
2. The test equipment and (Tester) shall comply with the Accuracy Requirements for field testers as defined in the ANSI/EIA/TIA Standards for the specific cable type. The Tester including the appropriate interface adapter shall meet the specified Accuracy Requirements. The Tester shall be within the calibration period recommended by the vendor in order to achieve the vendor-specified measurement accuracy. The Tester shall be calibrated to extend the reference plane of the Return Loss measurement to the permanent link interface. The Contractor shall provide proof that the interface has been calibrated within the period recommended by the Vendor.
3. The Pass or Fail condition for the channel pathway link-under-test is determined by the results of the required individual tests (ANSI/EIA/TIA) any Fail result yields a Fail for the link-under-test. In order to achieve an overall Pass condition, the results for each individual test parameter must Pass. A Pass or Fail result for each parameter is determined by comparing the measured values with the ANSI/EIA/TIA test limits for that parameter. The test result of a parameter shall be marked with an asterisk (*) when the

result is closer to the test limit than the accuracy of the field test. The Field Test Manufacturer shall provide documentation as an aid to interpret results marked with asterisks.

4. Provide all test equipment, Certified Testing Personnel, and setups. Shall comply with ANSI/EIA/TIA and Equipment Manufacturer's recommendations and Standards of practice.
 5. Provide six copies of all test reports, bound in three ring binders and three copies digital CD/DVD format using Adobe Portable format software, to Owner's Representative.
 6. The Contractor shall repair or replace equipment, cables, outlets, connectors, splices, terminations, etc. identified during testing as not complying with the Contract Documents, without additional cost to the Contract. Retest all replaced or repaired components at Contractor's expense.
- B. Twisted Pair Copper Wire Testing
1. Channel insertion loss (dB).
 2. Channel near-end crosstalk NEXT loss (dB).
 3. Channel equal-level far-end crosstalk ELFEXT (dB).
 4. Channel return loss (dB).
 5. Channel power sum PSACR (dB).
 6. Channel propagation delay, propagation speed, and delay skew.
 7. Channel wire map and circuit length.
 8. Channel ring-out test for continuity and correct point-to-point matching terminals.
 9. Channel DC resistance and capacitance.
 10. Channel attenuation-to-crosstalk ratio ACR.
- C. Coaxial Cable Testing
1. Channel full specified frequency spectrum attenuation insertion loss (dB).
 2. Channel wire mapping, ring-out and circuit length.
 3. Channel propagation delay and propagation speed.
 4. Channel impedance and continuity for center conductor and shields.
- D. Fiber Optic Cable Testing, Optical Testing for Each Specified Wavelengths for Both laser and LED sources.
1. Channel link insertion losses (dB).
 2. Channel loop-back attenuation (dB).
 3. Channel signature optical time domain reflectometer OTDR, for installation characterization testing (event and attenuation resolution dead zone at specified wavelengths, shall be less than 10-feet).
 4. Channel continuity and correct point-to-point matching terminals.
 5. Channel propagation delay and propagation speed.
 6. Channel fiber optic mapping, circuit length, and tracing.

3.02 FIBER OPTIC CABLE TYPE

- A. General
 - 1. Cables shown as fiber optic type shall comply with the following installation locations.
 - 2. Provide matching compatible outlets and terminate all fiber optic cables into matching fiber optic connectors.
 - 3. Provide matching compatible outlets and terminate all fiber optic cables into matching outlet fiber optic connectors.
- B. Provide loose tube gel filled or indoor/outdoor type fiber optic cable for any of the following installation location conditions.
 - 1. Inter building (between buildings).
 - 2. In a conduit or raceway located underground below grade.
 - 3. In an exposed outdoor conduit or raceway not located underground or below grade.
 - 4. Do not install loose tube gel filled type fiber optic cable inside a building or exposed on a building without providing Rigid Steel (RGS) conduit raceway for the loose tube gel filled fiber optic cable along the entire length of the cable inside or on the building located above finish grade.
- C. Provide tight buffered or indoor/outdoor type fiber optic cable for any of the following installation location conditions.
 - 1. Intra-building (inside a building) where raceway continuously encloses the cable and the raceway is not located underground, below grade.
 - 2. In an exposed outdoor conduit or raceway not located underground or below grade.
- D. Provide plenum rated type fiber-optic cable insulation for any of the following installation location conditions. Additionally, Cables shall be rated Limited-Combustible (LC) type UL FHC-25/50.
 - 1. In any air plenum (supply or return) when a conduit or enclosing raceway is not provided for the entire cable length.
 - 2. Where the cable is installed without a conduit or the cable is not fully enclosed in a raceway along the entire cable length in a building.
- E. Optical Fiber Quantity:
 - 1. The minimum fiber quantities in each fiber optic cable shall be as follows, but in no case less than indicated on the Drawings.
 - 2. Between main IDF (SUB-MDF) in separate buildings and the MDF main terminal rack fiber optic patch bay for the entire site/campus.
 - a. Six optical fibers, multimode and twelve optical fibers, single mode.
 - 3. Between satellite IDF terminal rack fiber optic patch bays and the main terminal rack IDF (sub-MDF) patch bay located in the same building.
 - a. Six optical fibers, multimode and twelve optical fibers, single mode.
 - 4. Between a terminal racks patch bay (IDF or MDF):
 - a. To an individual workstation outlet located inside the same building - two multi-mode optical fibers, (typical only for locations where fiber is specifically shown on the Drawings for the specific workstation outlet).

- b. To each network file server outlet location whether or not shown on the Drawings, 4-optical fiber, and multimode.
5. Other locations as indicated on the Drawings or described in the Contract Documents.

3.03 COPPER WIRE CABLE TYPE

- A. General
 1. Cables shown as copper wire type shall comply with the following installation conditions, unless noted otherwise on the Drawings.
 2. Provide matching compatible outlets and terminate all copper wire cables into matching copper wire connectors.
- B. Cable Types and Quantities - Cable types and quantities shall be as follows unless specifically noted otherwise on the Drawings. The following minimum type and quantity of copper wire cables from each individual workstation/device outlet, to the respective terminal equipment patch panel/bay, (unless specifically noted otherwise), but in no case less than what is shown on the Drawings and in no case less than one 4-pair cable to each outlet "Jack" position:
 1. Two Category-6, UTP 4-pair cable:
 - a. Each network workstation outlet location.
 - b. Each network "wireless-access-point" outlet location.
 2. One Category-6 UTP 4-pair cable, for each telephone handset (instrument) workstation outlet location.
 3. Trunking cable (Category-5E):
 - a. Between each separate building, 50-pair UTP cable.
 - b. Between each IDF's and/or MDF's in the same building 25-pair UTP cable.
- C. Provide plenum rated copper wire cable insulation for any of the following installation location conditions. Additionally, cables shall be rated Limited-Combustible (LC) type UL FHC-25/50.
 1. In any air plenum (supply or return) when a conduit or enclosed raceway is not provided for the entire cable length.
 2. All locations where the cable is installed without a conduit or the cable is not fully enclosed in a raceway along the entire cable length in the building.

3.04 CABLE INSTALLATION

- A. General
 1. Cables connecting to equipment racks and terminal blocks shall be installed with not less than 6-feet of slack cable between the equipment rack/terminal block and terminal backboard. The slack cable shall be coiled and supported on the backboard and/or cable tray.
 2. Cables in terminal closets and terminal rooms shall be trained, dressed, and racked on the plywood backboards. Provide cable, metal support arms and re-enterable type cable support rings not less than 12-inches on center mounted onto the plywood along the entire length of all cables.
 3. Provide separate routing paths on plywood backboards for fiber-optic cables, computer data and copper wire cables and telephone/voice copper wire cables and multimedia,

audio/video, TV cables. Provide separate routing paths on plywood backboards for shielded copper wire cables and unshielded copper wire cables.

4. Cables shall be routed parallel to floors and walls. Do not route cables diagonally on backboards.
5. Spare cable slack
 - a. Provide 25-feet of spare cable slack where unterminated cables are specified at terminal backboards.
 - b. Provide a minimum of 18-inches of slack cable in each workstation outlet box and outlet locations.
 - c. Provide 10-feet of cable slack in ceiling above each workstation outlet.
 - d. Provide 24-inches of slack in each cable at patch panel locations.
 - e. Coil and "Velcro" wrap slack cable.
6. Provide "horizontal wiring" cables installed from individual computer/data workstation outlets to respective terminal closet/room patch panel. Cables shall be continuous without cutting or splices.
7. Provide "horizontal wiring" cables installed from individual workstation telephone/voice handset outlets to respective terminal closet/room terminal patch panels. Cables shall be continuous without cutting or splices.
8. Provide "backbone" cables installed between MDF/IDF terminal rooms/closets patch panels. Cables shall be continuous without cutting or splices.

B. Cable Pulling Lubrication

1. Cable pulling lubricants shall be specifically approved by the Cable Manufacturer. The following lubricants shall be used where approved by the Cable Manufacturer.
 - a. Slip X -300, American Colloid Co.
 - b. Bishop #45, Bishop Electric.
 - c. MacLube CA51, MacProducts.
 - d. Minerallac H2B, Minerallac Electric.
 - e. Winter grade #7437-PC, General Machine Products.
 - f. Gel-lube 7/5, Cable associates.
 - g. Polywater, A, C, G, American Polywater.
2. Lubricants shall be continuously applied as cable enters raceway.

C. Cable Installation:

1. Do not pull conductors until factory test reports have been submitted and reviewed.
2. Minimum bending radius of fiber optic cables shall not be less than the following. Maximum pulling tension shall not exceed the following. In no case shall the Manufacturer's recommendations be violated.

<u>Cable Type</u>	<u>Cable Fiber Quantity</u>	<u>Mini. Bend Radius</u>	<u>Maxi. Pulling Tension</u>
Loose Tube	2-84	9 inches	600 pounds
Loose Tube	86-192	10 inches	600 pounds
Tight Buffered	2-12	5 inches	400 pounds

Tight Buffered	14-24	7 inches	600 pounds
Tight Buffered	26-28	11 inches	1100 pounds
Tight Buffered	48-72	12 inches	1200 pounds

3. The minimum bending radius for copper wire cables shall be 10-times the cable outside diameter. The maximum pulling tension and minimum bending radius shall not violate Manufacturer's recommendations.
4. Cables installed in manholes and pullboxes on terminal backboards shall be installed on wall mounted cable support racks.
5. Provide a full 360-degree loop of cable around manhole and pullbox interiors.
6. The attachment of pulling devices directly to the cables shall be with individual split mesh basket grips. Direct connection for pulling cables to cable fibers and copper wires shall not occur. Securely tape cable ends to prevent moisture or pulling compound from penetrating cable.
7. The attachment of the pulling device to the cable basket grips shall be made through a swivel connector.
8. The Contractor shall ensure that the cables are fed straight into the raceway taking care to avoid short bends, sharp edges, and cable "cross-overs".
9. All lashings used for temporary bunching of the individual cables shall be removed before the cables enter the raceway.
10. Cables shall be "pulled through" or pulled from a "center of run pull" without splices or terminations and minimize cable rolling tension. Lead out the cables at all manholes, pullboxes and conduits taking care to feed them in again by hand for the next portion of the cable run.
11. For each cable pull where a cable direction change is required, flexible feed-in tubes, pullout devices, multi-segmented sheaves etc. shall be used to ensure proper cable pulling tensions and side wall pressures. Cables shall not be pulled directly around a short right-angle bend. Any device or surface the cable comes in contact with when under pull-in tension shall have a minimum radius 50% greater than the final specified minimum installed cable bending radius. The maximum possible size radius sheaves and feed-in tubes, usable in the available working space, shall be provided in all situations, to insure the minimum possible cable side wall pulling pressure. Do not use devices with multi-segment "roller" type sheaves.
12. Cable lengths over 50 feet shall be machine pulled not hand pulled into and through all raceways. Cables shall be pulled in a continuous, smooth operation without jerking or stop-start motion after initiation of pull. Maximum cable pulling speed shall be less than 50 feet per minute. Minimum cable pulling speed shall be greater than 15 feet per minute.
13. Cables shall be pulled straight into or out of the raceway without bends at the raceway entrance or exit. Pull in cable from the end having the sharpest bend (i.e., bend shall be closest to reel). Keep pulling tension to minimum by liberal use of lubricant, hand turning of reel, and slack feeding of cable into duct entrance. Employ not less than one man at reel and one at manhole or pull-hole during this operation. Cables shall be pulled directly from cable reels.

14. Cables shall be trained or racked in trenches, vaults, manholes and pull boxes with consideration given for the minimum specified bending radius of the cable and the possibility of cable movements due to load cycling. The cables shall be racked and supported in such a manner that adequate space is allowed for splicing and the cables shall always be fanned out from the duct or conduit so as not to cross other ducts, conduits or cables. To prevent damage from falling objects or Personnel entering the manhole the cables shall not pass directly under the manhole opening.
15. Cable shall be supported in manholes, pull boxes and vaults a minimum of 18-inches on center with cable racks. Provide hot dip galvanized, T-slot racks and support arms. Secure cables to racks with porcelain supports for each cable on the racks. Loosely lash cables to racks. Splices shall be directly supported, on racks. Do not install cables more than one feeder on the same rack hook.
16. Cables shall be routed the long way around manhole, pull-hole, etc. with not less than a full 360-degree loop around the perimeter walls unless noted otherwise.
17. Existing conductors shall be protected at all times when Contract work occurs in the same area, including but not limited to pullboxes, vaults manholes, cable trenches etc. Provide temporary electrical insulating blankets and barriers over existing conductors to reduce the possibility of accidental mechanical damage to existing conductors.
18. Where cable tray is provided, all cables shall be routed and trained on the cable tray. The cables shall enter the cable tray and route along the tray prior to entering any equipment racks or computer works station outlets.
19. A dynamometer to measure pulling tension shall be used on all cable runs in excess 200 feet or with more than 180 degrees in bends. The actual pulling tension value shall be calculated and recorded for each pull.
20. Bends shall not be made in cable splices or terminations.
21. The portions of cables installed without raceways or cable tray supports shall be installed with metal "J-hook" cable supports.
 - a. The "J-hooks" shall provide multi-tiered "J" shaped hooks, with wide flat cable support base (0.5-inch wide minimum) and smooth rounded corners, specifically designed for copper wire and fiber optic infrastructure cable support. As manufactured by Erico Inc.
 - b. The individual "J-hook" attachment to the building structure shall be metal, "beam clamp", "hanger rod", clevis hanger styles as applicable for each attachment location.
 - c. Install "J-hooks" not more than 48-inches on center along the entire cable length and within 6-inches of each cable change in direction. Locations of "J-Hooks" and tension of cables shall insure between 4-inches and 6-inches of cable sag between adjacent hooks. Secure cables to "J-hooks" with re-enterable cable tie wraps. "J-hook" supported cables, bundle cables together with re-enterable tie wraps not less than 12-inches on center along the entire cable length.
 - d. Each J-hook shall not support more than twelve individual cables. Provide multiple "tiered" J-hooks for additional cable quantities at each location.
 - e. "Bridle rings" shall NOT be used to support cables.

- f. Cables shall not lie directly on nor attach to ceilings, ceiling hangers, lighting fixtures, air ducts, piping, or equipment.
- 22. Re-enterable cable tie wraps shall be, "limited-combustible" and air plenum rated, reusable, color-coded. Chemically and mechanically compatible with the respective cables and install locations. Shall allow multiple open-close operations for securing cables.
- 23. Electronic network cables containing non-dielectric components shall be installed with a minimum separation from other electrical power conductors and equipment as follows:

<u>Equipment Type</u>	<u>Minimum Separation</u>
a. Lighting fixtures	12 inches
b. Electric motors, electric solenoids, electric Heaters	40 inches
c. Transformers	48 inches
d. Circuits over 100 volts to ground, in metallic raceways	5 inches
e. Circuits over 100 volts to ground, in non-metallic raceway or without any raceway	12 inches
f. Circuits over 100 volts to ground, suspended on overhead pole lines	48 inches

D. Movement, Storage, and Handling of Cable:

- 1. Reels of cable shall not be dropped from any height, from trucks or other transporting equipment.
- 2. Lift and move cable reels using following methods:
 - a. Crane or boom type equipment-insert shaft (heavy rod or pipe) through reel hubs and lift with slings on shaft, with spreader or yoke to reduce or avoid sling pressure against reel head.
 - b. Fork lift type of equipment may be used to move smaller, narrower width reels. Fork tines should be placed so that lift pressure is on reel heads, not on cable, and shall reach all the way across reels so lift is against both reel heads.
 - c. Reels may be moved short distances by rolling. Reels shall be rolled in the direction indicated by arrows painted on reel heads. Surfaces over which the reels are to be rolled shall be solid clear of debris, and clear of protruding stones, humps, etc. which might damage the cable if the reel straddles them.
- 3. Storage of reels of cable:
 - a. Cable ends shall be sealed prior to shipment to prevent moisture entry into cable. Cable ends shall remain sealed at all times including during installation. Where ends seals are removed, reseal cable ends by stripping cable finishes back 2-inches down to insulation. Then apply four layers of an insulating tape crisscross over the cable end and carry back at least 4-inches onto cable outer finish. Add a containing cover of two layers of vinyl electrical tape completely over the end seal.
 - b. Cable reels shall be shipped with factory applied lagging (protective cover) left in place until removal is absolutely necessary. Additional covering such as tarpaulin, plastic sheeting, etc. shall be used if cable is to be stored outdoors.
 - c. Store reels of cable on a firm surface, paved, or on planking to prevent settling into soft ground.

- d. Use fencing or other barriers to protect cables and reels against damage by vehicles or other equipment moving about in the storage area.

3.05 CABLE SPLICES

A. General

1. Splice(s) in cables shall occur only in the following locations:
 - a. Pullboxes or manholes.
 - b. Terminal backboard, closets, or rooms.
 - c. Equipment racks.
 - d. Wall mounted interface cabinet.
 - e. Do not splice cables in conduit, cable tray, raceways, or plenums.
2. Polarity and color-coding shall be maintained consistent through splices, terminations, and outlets for the entire electronic network system.
3. Cable splices in outdoor areas, manholes, and pull holes shall be watertight, inside universal splice enclosures.

B. Fiber optic cable splices unless specifically indicated otherwise below, fiber optic cable splices between fiber optic-cable fibers shall be fusion type splices.

1. Splices between loose tube gel-filled fiber optic cable fibers shall be fusion type splices.
2. Splices between indoor/outdoor fiber optic cable fibers shall be fusion types.
3. "Pigtail" splices of tight buffered and indoor/outdoor fiber optic cable fibers to loose tube gel filled cables shall be fusion type splice.
4. Splices between tight buffered fiber optic cable fibers to indoor/outdoor fiber optic cables shall be fusion type splice or mechanical type splice.
5. Splices between tight buffered fiber optic cable fibers shall be mechanical type splice or fusion type splice.
6. "Pigtail" splices of tight buffered fiber optic cable fibers to tight buffered fiber optic cable fibers shall be mechanical type splice or fusion type splice.
7. Fiber optic splices shall be performed to maintain the data transmission rates specified for the entire respective system.

C. Copper Wire Splice

1. Copper wire extending from infrastructure workstation outlets to respective equipment rack patch panel outlets shall not be cut or broken and shall be continuous end to end.
2. Copper wire extending from telephone/voice workstation outlets to respective terminal blocks shall not be cut or broken and shall be continuous end to end.
3. Copper wire splices shall be performed to maintain the data transmission rates specified for the entire respective system.

3.06 CABLE TERMINATIONS

A. General

1. Infrastructure workstation outlets connecting to ports in patch panels shall be grouped together in the patch panel by outlet function, room location and building area location

(i.e., Group #1 Room #120 1st floor: Group #2 Room 200 east wing, etc.). Each group shall be identified with engraved (etched) nameplates indicating grouping identification and individual port numbers.

2. Polarity and color coding of cable connections at splices, terminations and outlets shall be consistently maintained throughout the entire electronic network system.
3. Terminate all cables onto respective outlets connectors, interconnection couplers and terminals. Terminations shall comply with Manufacturer's recommendations, ANSI/TIA /EIA-568C related Standards, Amendments and TSB.
4. Fiber optic cable fiber strands and copper wire cable conductors terminated at outlet locations shall be connected with a strain relief device attached to the cable jacket to prevent cable tension from being transmitted to the termination connectors.
5. Cable terminations shall be performed to maintain the transmission rates specified for respective system.

B. Fiber Optic Terminations

1. Individual fiber-optic fibers shall each be terminated with a fiber optic fiber connector. The connector for each fiber shall be "plugged" into separate fiber-optic fiber interconnection couplers on the rear of each respective outlet.
2. Each fiber optic termination ferrule shall be inspected, after completion of the termination, visually with a fiber optic inspection microscope and an interferometer, to ensure fiber "undercut", "protruding" fiber, over polish and under polish of fiber termination ends does not exist in the finished termination ferrule.
3. Fiber-optic cables terminated between two fiber optic patch panels located in separate equipment racks. The fibers shall be paired together for purposes of identification. Each pair of connectors for fibers shall be "plugged" into separate, physically adjacent fiber optic fiber interconnection couplers at each patch panel. The horizontal/vertical arrangement of paired patch panel fiber couplers shall match at both ends of the fiber cable.
4. Fiber optic cable fiber strands terminated at patch panels shall be installed with a minimum of 540 degrees of each fiber strand looped around the splice tray individual fiber "training" rings.
5. Fiber optic cable connecting from infrastructure workstation outlet to a fiber optic patch panel.
 - a. The connectors for fibers shall be "plugged" into separate, physically adjacent fiber optic fiber interconnection couplers.
 - b. The patch panel coupler shall be color coded to identify the polarity of the transmitting and receiving optical fibers.
6. Fiber optic cable connections at workstation outlets.
 - a. The connectors for fibers shall be "plugged" into separate physically adjacent fiber-optic fiber interconnection couplers in the outlet.

C. Copper Wire Terminations

1. Where occurs, the shield on metal shielded copper wire shall be terminated and connected to the shield grounding connection at each termination point.

2. Twisted wire pairs shall not be untwisted for a length of more than 0.4-inches at any location and the cable jacket shall not be stripped back not more than 0.5-inches any location including splices and terminations.
3. Unless specifically directed otherwise by the Owner's Representative, Pin assignment for wiring terminations shall comply with ANSI/TIA/EIA-568C type T568A or T568B as required for compatibility with the electronic network equipment. The termination type shall be consistent throughout the Project Contract area.

3.07 EQUIPMENT RACKS

A. General

1. Install, assemble, mount and connect devices and equipment in the respective equipment racks, bolted securely to the rack frame with stainless steel hardware. "Star" style lock washers shall be provided to insure an electrically continuous ground path between the equipment/devices and rack frames.
2. Provide blank metal filler panels to close unused equipment "front" mounting space in equipment racks, Manufacturer's standard finish color.
3. Provide a copper wire outlet connector in the respective equipment rack for each remote copper wire infrastructure workstation outlet and copper wire cable shown connected to the respective equipment rack, plus the spare copper wire outlet connectors required in the Contract Documents. The copper wire outlet connectors in the equipment racks shall be provided in equipment rack mounted copper wire patch panels. In no case shall the quantity of equipment rack mounted copper wire outlet connectors be less than the quantity of cables indicated on the Drawings, plus required spaces/spares.
4. Provide fiber optic fiber connectors and fiber optic fiber interconnection couplers in the respective equipment rack for each remote fiber optic infrastructure workstation outlet, and fiber optics cable fiber shown connected to the respective equipment rack, plus the spare fiber optic fiber connectors required in the Contract Documents. The fiber optic fiber connectors and fiber optic fiber interconnection couplers in the equipment racks shall be provided in equipment rack mounted fiber optic fiber distribution enclosures (RTDE). In no case shall the quantity of equipment rack mounted fiber optic fiber connectors and fiber optic fiber interconnection couplers be less than the quantity of cables indicated on the Drawings, plus required spaces/spares.
5. Fiber optics cable fibers specifically shown as non-terminated "splicing-thru" in the equipment rack shall route through fiber optic splice only enclosures (RMSE), mounted in the respective equipment rack.
6. The maximum quantity of cable terminations, in each equipment rack mounted patch panels shall not exceed the following:
 - a. 100% copper wire outlet connectors, 672 maximum per 42U rack. 144 maximum in 24-inch high, 240 maximum in 30-inches high and 432 maximum in 48-inches high mini-equipment racks.
 - b. 100% fiber optic fiber terminations, 144 maximum per rack.
 - c. Combination of copper wire outlet connectors and fiber optic fiber terminations in the same rack; 48 maximum fiber optic fibers plus 144-maximum copper wire outlet connectors per rack.

- d. In addition to the quantity of patch panel outlets for termination of incoming and outgoing cables, provide not less than an additional 15% of patch panel spare outlets in each equipment rack for future use.
 7. Provide additional equipment racks, quantity of racks to ensure the maximum specified quantity of terminations in single rack are not exceeded and the quantity of cable terminations complies with the Requirements of the Contract Documents.
 8. Terminal racks, equipment locations, patch panels, and cross connects shall be arranged to allow for natural cabling progression, minimize crossing of cables and allow easy access to each system component.
 9. Equipment Rack Anchorage:
 - a. Equipment racks installed on raised "access floor" systems, shall be supported and anchored with bolts that extend into the "structural" floor located below the "access floor".
 - b. Securely anchor the support arms of swing gate racks to the wall structural support system.
 - c. Securely anchor fixed support base of the racks to the floor.
 - d. Mounting method shall support the total rack weight including installed equipment, but in no case less than 500-pounds with a 2.0 times safety factor.
 - e. Attachments and anchorages shall comply with the Requirements for Earthquake.
 10. Unless specifically noted, otherwise provide the following equipment rack types:
 - a. Floor standing equipment racks containing patch panel locations, computer/data network HUBS/switches and computer data network concentrators, shall be Open Frame style 4-post equipment racks.
 - b. Wall mounted external to dedicated IDF/MDF terminal rooms/closets (i.e., inside individual classrooms), shall be Mini-Equipment racks.
 11. Install ground bus, PDU/SPD, cable management rings, equipment, patch panel and patch panel outlets, etc. in equipment racks.
 12. Equipment rack terminology:
 - a. The location containing the main campus equipment rack location shall be identified as the Main Distribution Frame (MDF).
 - b. The locations remote from the MDF containing satellite equipment racks shall be identified as Intermediate Distribution Frames (IDF).
 - c. An individual building located on a multi-building campus site with multiple equipment rack locations in the building, the building main rack location shall be identified as Sub-MDF and the remaining equipment rack locations in the building shall be identified as IDF.
- B. Mini-Equipment Racks:
1. Install surface mount on the wall, on wall mount horizontal "C" channels.
 2. In public spaces the bottom of the rack shall not be less than 6-feet – 6-inches above finish floor. Top of rack shall be tight to ceiling.
 3. Position the rack to allow the door section, and center section to swing open a full 90 degrees Arc without obstructions.

4. Connect raceways to the non-moveable pan section.

3.08 GROUND (ADDITIONAL REQUIREMENTS)

- A. Electronic Equipment MDF, IDF and Terminal Rooms and Closets
 1. Terminal Equipment Ground Bus (TEGB) - Provide a wall mounted TEGB ground bus in each MDF location. Also provide a TEGB where two or more equipment racks are provided in each IDF. The TEGB ground bus shall be copper ¼-inch by 2-inches (nominal) by 12-inches long (minimum). Install the TEGB on the wall with a minimum of two "stand-off" electrical insulators. Drill and tap the ground bus and provide bolted type ground lugs for connection of each ground conductors size #10AWG - #1AWG. Provide four spare unused ground lugs on the TEGB.
 2. Provide 1.25-inch conduit with 1#1AWG copper insulated ground conductor from the TEGB homerun to the building main ground reference bus. Provide 1.25-inch conduit with 1#1AWG copper insulated ground conductor from the TEGB homerun to the nearest building main structural steel member and to the nearest metal cold water pipe larger than 0.6-inch diameter pipe.
 - a. Provide the same ground connections from the equipment rack ground bus where only a single equipment rack occurs in the IDF location.
 3. The ground conductor required from the TEGB to the building main ground reference bus may be looped and connected between separate TEGB ground bus locations if all the following conditions are met.
 - a. The ground conductor is increased to 1.5-inch conduit with 1#2/0AWG copper insulated and the total end to end length does not exceed 300-feet.
 - b. The building exceeds two floors in height.
 - c. Not more than four TEGB buses are connected to the same "looped" ground conductor.
 - d. The TEGB ground conductor is continuous (not cut, spliced or broken) along its entire length.
 - e. The TEGB ground conductor is connected to the TEGB ground buses with a UL listed "Exothermic" welding process.
- B. Equipment Racks:
 1. Provide a separate #12AWG copper stranded green insulated ground conductor from each individual equipment element in the rack to the respective rack ground bus.
 2. Provide a separate #8AWG copper insulated ground conductor from each equipment rack ground bus to the TEGB terminal equipment ground bus located in the same space.
 3. Where only one equipment rack is installed, provide 1.25-inch conduit with 1#1AWG copper insulated ground homerun conductor from the equipment rack ground bus homerun to the building main ground reference bus and provide 1.25-inch conduit with 1#1AWG copper insulated ground conductor from the TEGB or single equipment rack ground bus (as applicable), to the nearest building main structural steel member and to the nearest metal cold water pipe larger than 0.6-inch diameter pipe.
 4. Provide 1.25-inch conduit with 1#4AWG copper insulated ground conductor from each wall mounted fiber interface cabinet to the respective TEGB ground buses.

5. Provide a 1#10AWG copper insulated ground conductor connecting in a continuous loop to all miscellaneous cable trays and metal support equipment located in the terminal closet or room and connect to the TEGB ground bus.
- C. Telephone/Voice Terminal Blocks:
1. Provide a separate #8 copper insulated ground conductor from each terminal block section ground bus to the TEGB terminal equipment ground bus.
 2. Provide a separate #6 copper insulated ground conductor from the terminal room/ closet to the lightning ground system.

3.09 WALL MOUNTED FIBER INTERFACE CABINET - WMIC

The WMIC shall provide the interface/transition for any loose tube gel filled fiber optic cable entrance into a building for "Pigtail" terminations into equipment located in the building or "thru splices" onto other areas.

3.10 IDENTIFICATION (ADDITIONAL REQUIREMENTS)

- A. General
1. Fiber optic and copper wire cables shall be identified in each manhole, pull box, equipment rack, patch panel and computer workstation outlets.
 2. Infrastructure documentation, identification labels and color coding shall comply with ANSI/TIA/EIA-606A Administration Standard for Telecommunications Infrastructures, Class-1 through Class-4. Provide management software MS-Windows-based single user license, with all as-built data entry documentation information complete.
 3. Color-Coding of Termination (Specific additional Owner's Requirements): Termination at the MDF/IDF termination areas and at telephone terminals shall be color-coded with colored designation strips. Designation strips will be marked with architectural area designation as indicated on the Plans. Colored designation strips shall be assigned as follows:

a. Data Outlets	Black
b. Voice Outlets	Red
c. Multi-pair copper (MDF/IDF)	Green
d. Multi-pair copper (Voice)	Yellow
- B. Identification tags shall include the following information:
1. Cable name as indicated on Drawings (i.e., HV1, F4, MSB3 etc.).
 2. Installation month and date (i.e., 3/92, 4/78 etc.).
 3. Conductor size conductor type (i.e., loose tube fiber; (#24AWG ScTP Category 5, 200 pair, telephone/voice etc.).
 4. Feeder taps to equipment or building shall also be identified with equipment name or building (i.e., library, SW1, Rack #21, etc.)
- C. Identification Tags
1. Tags shall be 1/8-inch thick 98% lead, approximately 2-inch square with chamfered corners. Two holes shall be drilled for attachment to primary cable. Lettering shall be 1/8-inch high, engraved or die stamped. Attach tags to primary cables with two #14AWG

(THWN insulated) solid copper conductors "twist-tied", with insulated CAP wire-nut on the tie-wire ends, to cover sharp edges of tie-wire conductor.

2. Alternate identification tags, at the Contractor's option in lieu of lead tags. Provide polypropylene tag holders with interchangeable, yellow polypropylene tag with black alphanumeric character sets. Characters shall be approximately 0.25-inch high. As manufactured by Almetek industries "EZTAG" Ledgewood, New Jersey.
- D. Equipment and outlet naming identification and color-coding shall comply with ANSI/EIATIA latest revision.
1. Naming method for equipment, outlets, and cables; where a position in the naming string is unused, provide multiple "*****" symbols.
Typical naming string "ADM-02-1141-PP17-1271"
 - a. "ADM" - Abbreviated Building Name or Number (i.e., Administration, B127, etc.)
 - b. "02" - Floor Level #2 or as applicable.
 - c. "1141" - Outlet, Equipment or Terminal Room/Closet name or room number as applicable.
 - d. "PP17" - Terminal Rack Patch Panel Identification.
 - e. "1271" - Individual Outlet or Port Identification.
 2. Connecting hardware color coding shall be as follows:
"Green" - Main central terminal location for entire site.
"White" - Distributed terminal locations other than the main terminal.
"Blue" - Horizontal wiring hardware systems for workstations.
- E. Documentation and Labeling (Specific Additional Owner's Requirements)
1. The Contractor shall provide printed labels for all cables and cords, distribution frames and outlet locations. No labels are to be written by hand.
 2. An example of appropriate classroom outlet documentation/labeling shall be as follows:
 - a. D = Data only
 - b. V = Voice only
 - c. 26 (numeric jack assignment on MDF, IDF or telephone terminal)
 - d. Two (MDF, IDF or telephone terminal number)
 3. An example of appropriate patch panel/punch block documentation/labeling shall be as follows:
 - a. Label on patch panel = D46/A/406
 - b. Type outlet:
 - 1) D = Data only
 - 2) V = Voice only
 - 3) 46 (numeric jack assignment on MDF, IDF or telephone terminal)
 - 4) A (school building designation)
 - 5) 406 (room number)

4. An example of appropriate inter-building cabling documentation/labeling shall be as follows:
 - a. Outlet label on LIU = 4/4-2/4
 - 1) 4 (school building number)
 - 2) 4-2 (IDF floor/closet room number)
 - 3) 4 cable pair or fiber number per color coding provided by Manufacturer.
 - F. Provide warning nameplates on fiber optic patch panels, fiber optic outlets, and any location where fiber optic cables are terminated. Minimum 1/8-inch high engraved/etched letters. "WARNING - LASER LIGHT SOURCE. DO NOT LOOK DIRECTLY AT OUTLET OR FIBER CABLE ENDS. RISK OF SEVERE EYE DAMAGE OR BLINDNESS".

3.11 TRUNKING CABLE TERMINAL BLOCKS

- A. The trunking cable terminal blocks shall be assembled in vertical sections, for wall mounting. Install adjacent vertical sections with not less than 8-inches blank space between sections, for cable training space.
- B. Install terminal blocks on plywood terminal backboard with #8 x 1-inch wood screws. Minimum 6 inches on center, along each side of each terminal block.
- C. Terminal block wire pair capacity:
 1. The minimum wire termination capacity shall not be less than 300-pairs of trunking cable conductors, at each terminal block assembly.
 2. Plus fifteen spare capacity.
- D. Trunking cable installation:
 1. Trunking cable and insulation shall be rated for installation in the locations shown on the Drawing, installed in conduit end-to-end.
 - a. Outdoor underground or exposed to sun, wet locations installed in conduit.
 - b. Inside the building installed in conduit.

END OF SECTION 27 21 00
021821/212276

SECTION 27 51 13
INTEGRATED COMMUNICATIONS SYSTEM

PART 1 - GENERAL

1.01 SCOPE

- A. Work Included: All labor, materials, appliances tools, equipment, facilities transportation and services necessary for and incidental to performing all operations in connection with furnishing, delivery and installation of the work of this Section, complete as shown on the Drawings and/or specified herein. Work includes, but is not necessarily limited to the following:
1. Examine all other Sections for work related to those other Sections and required to be included as work under this Section.
 2. General Provisions and Requirements for electrical work.

1.02 SUBMITTALS (ADDITIONAL REQUIREMENTS)

- A. Submit product data sheets and descriptive literature for all component parts.
- B. Submit block wiring diagram of the paging systems. Showing headend equipment, terminal cabinets, remote power supplies, and typical speaker for each zone.

1.03 EQUIPMENT QUALIFICATION

- A. The Specification is based on the equipment of Manufacturers who have been approved by the District and the Manufacturers herein named shall be considered as meeting the Requirements of this Specification. For all items which are identified by part number and Manufacturer the Performance Specifications which are published in the most recent Manufacturer's data sheets available at the time of bidding this project shall be applicable to the present work as though fully written out herein.
- B. All equipment shall conform to all local applicable Codes and Ordinances and shall be listed by Underwriters Laboratories.
- C. System shall be Bogen Multi Com to match existing paging/clock system on campus.

1.04 QUALIFICATIONS

To qualify as an acceptable Bidder, whether the bid is submitted to the District, his Agent, a General Contractor or a Sub-Contractor, the System Bidder or Contractor shall be qualified sound Contractor and shall hold a valid C61 License issued by the Contractors State License Board of California. The System Bidder or Contractor shall hereinafter be referred to as the Contractor. The Contractor shall hold all other licenses required by the legally constituted authorities having jurisdiction over the work. The Contractor shall be the factory authorized Distributor for the brand of equipment offered and shall have been engaged in the business of supplying and installing the specified type of system for at least 5-years. The Contractor shall maintain a fully equipped service organization capable of furnishing adequate repair service to the equipment.

PART 2 - PRODUCTS

2.01 MATERIALS

Comply with pertinent provisions of Section 26 05 00.

2.02 GENERAL

- A. Individual paging zones, each of which may be programmed in software to belong to any combination of zones plus all-call. Initially zones shall be provided and programmed as follows:
 - 1. One zone for each classroom interior speaker(s).
 - 2. One zone for corridor speakers, one zone per floor.
- B. The System shall be equipped with one program channel for distribution to any speaker or group of speakers on the system.
- C. System shall include inputs for connection of the telephone system so paging can be initiated from telephones.
- D. The head-end equipment is existing and located in the Main Administration MDF Room. Modify the existing equipment to serve the new construction.
- E. Power amplifiers shall be UL listed, with the following features:
 - 1. Each amplifier shall have than 1% harmonic distortion at its full rated output. Hum and noise level shall be greater than 105dB (A- weighted) below rated output. Frequency response shall be +1dB, 20-20,000 Hz.
 - 2. Input impedance shall be 20,000 ohms nominal balanced. Controls shall be provided for level control setting. Each amplifier shall be capable of delivering full rated output to 25V or 70.7V constant voltage lines.
 - 3. Exterior building-mounted speakers shall be driven by amplifier(s) separate from the interior speakers. Quantity and output rating of amplifiers driving exterior speakers shall be based on each speaker tapped at 3 watts. Provide spare amplifier capacity for the future addition of 25% additional exterior speakers.
 - 4. Quantity and output rating of amplifiers driving indoor speakers shall be based on each speaker tapped at ½-watt. Provide spare amplifier capacity for the future addition of 25% additional interior speakers.

2.03 CABLING

- A. Cable run in conduits below grade shall be approved by the manufacturer for the purpose.
- B. Cable serving speakers shall be a twisted pair of #16 AWG solid copper conductors with overall jacket.
- C. Provide multiple pairs cables for paging circuits from headend amplifiers to each building to match System Zoning Requirements.

2.04 SPEAKERS AND ACCESSORIES

- A. Interior speakers shall be 8-inch diameter paper cone type with line matching transformer. Interior ceiling-mounted speakers shall be flush mounted Atlas SD72W-KIT (includes D72 speaker, 62-8 baffle, CS95-8 backbox and 81-8R T-bar bridge kit).

- B. Exterior speakers shall be Atlas # APF15T with surface mount L20-213 backbox and L20-101 grille.
- C. Provide power supplies in the system terminal cabinets throughout the project as required to properly operate all speakers indicated.

PART 3 - EXECUTION

3.01 MATERIALS

Comply with pertinent provisions of Section 26 05 00.

3.02 WIRING DESIGNATION AND TERMINAL CABINET MAKE UP

All connections throughout the system shall be made on barrier screw terminals. All conductors in terminal cabinets shall be carefully formed and harnessed in a workmanlike manner.

3.03 INTERFACE

Provide connection between fire alarm control panel and class-passing equipment and between fire alarm control panel and paging system equipment. In the event of fire alarm alert, the fire alarm shall override the class-passing and paging systems.

3.04 PROGRAMMING

All programming shall be as directed by the District.

3.05 THE CONTRACTOR SHALL PROVIDE FOUR COPIES OF THE COMPLETE AS-BUILT DRAWINGS AND SERVICE MANUALS. THE DRAWINGS AND MANUALS SHALL INCLUDE THE FOLLOWING:

- A. Identification of all components and cable runs in the system. The identification numbers must match those used in construction.
- B. Service manuals and schematic diagrams of all active components used in the system.
- C. A complete manual must be assembled and organized to permit easy reference and cross-checking and to facilitate future servicing.
- D. A complete block diagram.
- E. All information shall be printed or typewritten.

3.06 TRAINING

Provide a minimum of two 4-hour periods to instruct District Personnel in proper operation of all systems. The first instructional period shall be held and videotaped prior to final acceptance of the systems. The second instructional period shall be within a period of 1-year after final acceptance of the systems, upon request of the District.

END OF SECTION 27 51 13

021821/212276

SECTION 27 51 26
PORTABLE ASSISTIVE LISTENING SYSTEM

PART 1 - GENERAL

1.01 SCOPE

- A. Work Included: All labor, materials, appliances tools, equipment, facilities transportation, and services necessary for and incidental to performing all operations in connection with furnishing, delivery, and installation of the work of this Section, complete as shown on the Drawings and/or specified herein. Work includes, but is not necessarily limited to the following:
1. Examine all other Sections for work related to those other Sections and required to be included as work under Division 26, 27 and 28.
 2. General Provisions and Requirements for electrical work.

1.02 SUBMITTALS (ADDITIONAL REQUIREMENTS)

Submit Block Wiring Diagrams and catalogs data showing component interconnection and descriptive literature for all component parts and cabinets.

1.03 EQUIPMENT QUALIFICATION

- A. All equipment shall conform to Federal, State and Local applicable Codes, Ordinances and AHJ, and shall be listed and labeled by Underwriters Laboratories.
- B. Assistive listening systems shall be provided in accordance with CBC Section 11B-219 and shall comply with CBC Section 11B-706.
- C. The minimum number of receivers to be provided shall be equal to 4% of the total number of seats, but in no case less than two. 25 % minimum of the receivers provided, but no less than two, shall be hearing-aid compatible in accordance with CBC Section 11B-706.3.
- D. If the system provided is limited to specific areas or seats, then such areas or seats shall be within a 50-foot viewing distance of, and have a complete view of, the stage or playing area. CBC Section 11B-219.4.

PART 2 - PRODUCTS

2.01 GENERAL

- A. The Assistive Listening System shall include the following items
1. Instructor (program source) wireless transmitter units.
 2. Student (audience) portable wireless receiver units.
 3. Plug-in microphones and earphones, for each unit.
 4. Multiple program source inputs for, Instructor's microphone, respective room audio/video (A/V) system input/output and instructor's computer audio input/output.
 5. System accessories.

B. Function

1. The assistive listening system shall provide amplified available audio programs for hearing impaired students/audience, originating from classroom/stage/room instructors and audio/video instructional program source materials, and equipment in respective building spaces, rooms, classrooms, and outdoor areas.
2. The audible program shall be transmitted wireless from the program source to the student/audience, with reception coverage throughout not less than approximately 80% of the respective floor space/area space.
3. Shall provide automatic stereo or mono audio full system operation, depending on program source input.
4. The system in each space shall comply with Federal ADA, State and Local AHJ Requirements for the hearing impaired.

2.02 MATERIAL (INFRARED WIRELESS)

A. General

1. All equipment shall be the product of the same Manufacturer.
2. The receivers and transmitters shall be US Government FCC and Industry Canada-approved.
3. Provide power on-off control on each unit, to extend battery duration.
4. As manufactured by Williams Sound; or PhonicEar; or Listen Technologies; or Centrum Sound.

B. Master (Program Source) Transmitter (Infrared Emitter) Units

1. The infrared emitter/transmitter shall be compact, portable units, self-contained ABS/plastic housing/enclosure.
2. The emitter panel shall be a dual-channel system operating on both 2.3 and 2.8MHz invisible infrared light waves frequencies. The channels shall be designated "CHANNEL A" for the left and "CHANNEL B" for the right.
3. The emitter shall provide left and right AUDIO IN jacks to accept an input signal from a sound system, left and right "SYNC IN/SYNC OUT" jacks for master/slave daisy-chaining with other emitters if desired, and left and right "MIC-IN" jacks to accept an audio signal from a microphone or Audio/Video preamplifier.
4. The emitter shall provide separate LED input level detectors for each channel which illuminate when the audio signal peaks. Stereo and mono audio processing.
5. The emitter shall be mounted by the following methods:
 - a. Portable mounted to a table-top-or floor-stand, using accessory support-stand adapter.
6. Each emitter shall provide an array of not less than 130 infrared LEDs covered by an infrared transparent acrylic lens. The infrared signal from each emitter shall cover not less than 3,000 sq. ft. (32,000 cubic feet) enclosed space. Note: For room sizes smaller than 3,000-sq. ft., the infrared transmitter/ emitter infrared output shall be reduced to accommodate the actual smaller room square feet size and height.

7. 120-volt 60Hz AC input to nominal 24-volt DC output (plug-in "power-brick") power supply external transformer shall be UL approved, with cable "plug-in" connection to emitter/transmitter. Provide remote system master on-off control.
 8. Slave emitter/transmitter for rooms exceeding 30,000-cubic feet. Provide one additional infrared emitter/transmitter repeater slave unit, for each additional 30,000-cubic feet room volume, or fraction thereof. The slave repeater shall receive and retransmit the program signals from the master unit. Provide one 100-feet long "master-to-slave" auxiliary portable extension wire cable for each slave unit.
 9. Provide a quantity of nine emitter/transmitter "master" units, plus additional "slave" units for adjusted room sizes.
- C. Student/Audience Receiver Units
1. Battery Power
 - a. Power for each unit operation shall be supplied by internal, changeable rechargeable NiCad batteries and alternately by alkaline disposable batteries. Rechargeable batteries shall be recharged without removal from the unit. Each unit shall have a charging indicator light. The batteries shall be recharged from either a portable charger/organizer and with wall transformer/two-unit chargers. The units shall operate for up to 40-hours with alkaline batteries, and up to 15-hours with NiCad (NiMH) batteries.
 - b. Provide power on-off control on each unit, to extend battery duration.
 - c. A protection circuit shall prevent battery "back-drain" if the power to the charger is turned off while the unit is being recharged.
 2. The receiver shall be a dual-channel unit for wearing around the neck with an adjustable strap. Stereo and mono audio reception and processing.
 3. Compatible with the transmitter (emitter) and operate on 2.3 and 2.8MHz frequencies invisible infrared light waves. Self-contained and switchable from "CHANNEL A" to "CHANNEL B" through a switch located on the back of the unit.
 4. The receiver shall provide an infrared light-gathering lens on the front of the unit to focus the light signal from the emitter onto the infrared detector element. The receiver shall detect and decode the infrared emitter/transmitter light source within a 160-degree acceptance angle.
 5. Audio squelch circuit which turns the output circuit off when the infrared signal is reduced or not received, with on/off and volume control.
 6. Output jack, which accepts any of the listening accessories. Headsets shall provide magnetic induction pick-up for hearing impaired, hearing aid interface operation.
 7. Shall be compact easily portable units, self-contained ABS/plastic housing/ enclosure with red infrared receiver lens. Shall clip to pocket or belt.
 8. Provide quantity of four infrared receivers for each master transmitter.
- D. Infrared System Accessories
1. Battery recharger portable charger/organizer pack.
 Locking, portable case with cover, shall accept a group of not less than twelve plug-in portable transmitters and receivers' units in each pack for simultaneous multi-unit

battery recharging. Provide a quantity of one organizer for each quantity group of twelve (or fraction thereof) receivers provided as part of the contract.

2. Stereo audio headset style automatic noise canceling microphones, integral on-off-volume control and with behind the neck support style. Each with 25-foot long extension cables and outlet plug-jacks to match transmitter outlet jacks. Provide two cables for each emitter/transmitter.
3. Equipment wall mount support brackets.
4. Auxiliary audio program source 15-foot long cables with plug-in at both ends to match transmitter jacks. Provide two for each transmitter.
5. Headset style earphones with cable and plug to match receiver jacks. Headsets shall provide magnetic induction pick-up for hearing impaired, hearing aid interface operation. Provide one headset for each receiver.
6. Rechargeable Ni-Cad (NiMH) batteries, one complete set for each unit.
7. Locking auxiliary equipment storage cases for cables, microphones, and headsets. Quantity and capacity as required to store all accessories.
8. Portable floor stand, for infrared emitter/transmitter units mounting and support, with variable height adjustment and tip-resistant weighted base. Provide one floor stand for each infrared emitter/transmitter.
9. Locking, portable case for infrared emitter/transmitter. One for each emitter/transmitter unit.
10. Provide microphone extension cable with plug to match microphone and infrared emitter/transmitter microphone input jack, 25-foot length. One for each microphone.

PART 3 - EXECUTION

3.01 GENERAL

- A. Each System General
 1. Assemble, set up, and test each transmitter, receiver, and accessories units.
 2. Install and fully charge all batteries prior to and after testing/set up is complete.
- B. Wireless Infrared Units
 1. Provide aiming and intensity adjustments of emitter/transmitter units to insure complete room coverage.

END OF SECTION 27 51 26

031821/212276

SECTION 28 31 00
INTRUSION DETECTION SYSTEM

PART 1 - GENERAL

1.01 SCOPE

- A. Work Included: All labor, materials, appliances, tools, equipment necessary for and incidental to performing all operations in connection with furnishing, delivery and installation of the work of this Section, complete, as shown on the Drawings and/or specified herein. Work includes, but is not necessarily limited to the following:
1. Examine all other Specifications Sections and Drawings for related work required to be included as work under Division 26, 27, and 28.
 2. General Provisions and Requirements for electrical work.

1.02 QUALIFICATION OF BIDDERS AND EQUIPMENT

- A. To qualify as an acceptable Bidder, whether the bid is submitted to the District, his Agent, a General Contractor or a Sub-Contractor, the System Bidder or Contractor shall be qualified Contractor and shall hold a valid License issued by the State of California Department of Consumer Affairs Collection and Investigation Services for the purpose of installing security systems. The System Bidder or Contractor shall hereinafter be referred to as the Contractor. The Contractor shall hold all other licenses required by the legally constituted authorities having jurisdiction over the work. The Contractor shall be the factory authorized Distributor for the branch of equipment offered and shall have been engaged in the business of supplying and installing the specified type of system for at least 5-years. The Contractor shall maintain a fully equipped service organization capable of furnishing adequate repair service to the equipment. The Contractor shall be financially able to provide a performance bond covering the work and the guarantee described. The Contractor shall provide that bond if requested.
- B. The equipment specified herein shall be DSC Power Series Pro from Tyco security product. Call DSC at 1-800-387-3630 for a list local factory authorized Supplier.
- C. The system shall be serviced by a field supported 2-year warranty.
- D. The Specification is based on the equipment of Manufacturers who have been approved by the District and the Manufacturers herein named shall be considered as meeting the Requirements of this Specification. For all items which are identified by part number and Manufacturer the Performance Specifications which are published in the most recent Manufacturers data sheets available at the time of bidding this project shall be applicable to the present work as though fully written out herein.
- E. All equipment shall conform to all local applicable Codes and Ordinances and shall be listed by Underwriters Laboratories.
- F. Installation Certification
1. Work and material for cables, cable terminations and related components shall be performed by certified Installers. The Installer shall be certified by the respective Product Manufacturers.
 2. The Manufacturers of the indicated work and material shall provide an Installer education/training and certification program for the supplied products.

3. The Installers performing the Contract Work for the indicated products, shall have attended, and successfully completed each of the respective Manufacturer's installation training education programs for the specified products.
4. Submit six copies of the Manufacturer's certifications for each Installer performing the work. The submittal shall be approved prior to initiating any related Contract Work.
5. Contract material installed, and work performed by Installers not complying with these Requirements shall be removed. Removal of work and material not in compliance with these Requirements shall be done at the Contractor's expense, without any additional cost to the Contract and without any Additional Contract completion due date extensions. New material and work required to replace the non-complying removed work and material shall be provided at the Contractor's expense, without any additional cost to the Contract and without any Additional Contract completion due date extensions.

1.03 PERFORMANCE REQUIREMENTS

- A. Provide main control panel, terminal cabinets with manufacture key lock, keypads, and site underground conduits as indicated.
- B. Provide a Dual technology PIR/Microwave 360° motion sensor(s) in each room having exterior doors, exterior glass, or skylights. Quantity of sensors in each room shall be as required to detect entry through exterior doors, exterior glass, or skylights.
 1. Motion detector should be installed center of room and sensitivity of microwave detection should be reduce to appropriate level for the room size which it is located and installed in according to Manufacture Specification.
- C. Provide a magnetic switch at the entry door to each building, near its respective keypad. Connect to the system to initiate a timing circuit for keypad operation.
- D. Provide magnetic switches at roof hatches.
- E. Provide all conduits, cabling, and outlet boxes required for a complete and operable system.
- F. Install all DSC LCD Keypads model HS2LCDPRO(RF)(P) in each exterior common area for each building to allow instructors disarming access at each building.
 1. Keypads shall be installed in a solid white polycarb enclosure and exterior thumb lock with "F" back-box Model number: STI-7511F-OW

1.04 SUBMITTALS (ADDITIONAL REQUIREMENTS)

- A. Submit evidence of having met with District Representatives as specified herein.
- B. Submit product data sheets for all switches, keypads, wiring devices, device plates, controllers, power supplies, cabinets, etc.
- C. Submit detailed Shop Diagrams including dimensioned plans, elevations, details, schematic and point-to-point wiring diagrams and descriptive literature for all component parts and cabinets.
- D. Submit six copies redrawn Building Floor Plans showing all components of the intrusion detection system including interconnecting cabling and conduits. Sensors shall be located on the Drawings in the location conforming to the Requirements stated herein. Drawings shall be prepared to scale and show all exterior glass, exterior doors, all interior and exterior building walls, roof hatches, architectural and structural elements relevant to the installation of the

system. Each zone shall be shown on the Plans. All Labeling of wiring should match redrawing Building Floor Plan.

PART 2 - PRODUCTS

2.01 SYSTEM FUNCTIONS

- A. Provide a complete and operable supervised intrusion detection system as shown on the plans including but not limited to master control panel, keypad stations, motion detectors, connections to door switches, a State Fire Marshal listed digital communicator, and an automatic dialer.
- B. Upon detection of an intruder by initiation of any device in the system, the system shall cause the annunciator LED to light and sound an alarm signal on the School's telecommunication system. Alarm information shall be sent by digital dialer to central station alarm monitoring agency.
- C. Systems shall detect the motion of a body taking not more than four steps in an area secured with motion detection equipment where entry doors or windows are possible access.
- D. Each building area shall be on a separate partition (area) with each Partition controlled separately so that any building area may be secured while others remain unsecured.
- E. The system shall be capable of off-site computerized access for remote access, programming, and control.

2.02 CONTROL PANEL

- A. Control/Communicator panel shall be a DSC Power Series Pro System control panel model number: (HS3248) compatible with an integral digital communicator and shall be Underwriters Laboratories listed. All external circuit connections shall be UL listed as power limited in accordance with the provisions of Article 760 of the California Electrical Code (CEC).
 - 1. Provide clear labeling of termination block which should state if the wire is a motion or door position switch and to which room number or exterior door or hall it is located in the building. The control/communicator shall be IP based.
 - 2. Two 18AWG 4 conductor shielded cables should be run from each building to the main headend location (Master control panel) to allow for complete interconnection, control and communication between all campus buildings
 - 3. Provided compatible keypads at minimum two entry points but may require addition entry point keypad if required by the district, if exterior access is available to upper floor levels a keypad should be install at those entry point on upper levels.
 - 4. Security system should be design and engineer to maximize each DSC HS3248 panel to ensure that all 248 hardwired available zones are be utilized before install addition HS3248 Control panel to reach campus wide security coverage. This should be accomplished by installing adequate amount of DSC Power Series compatible power supply, zone expanders, and keypads to ensure complete campus security coverage.

5. If more than one HS3248 is required at a campus, then one 1-amp Power Supply with four programmable outputs (HSM2204) shall be install at each axillary HS3248 location. For each addition axillary HS3248 there shall be one additional HSM2204 install at each Axillary HS3248 location. For each additional Axillary HS3248 install there shall be an additional HSM2204 installed at the Headend at the Master Control Panel (Main HS3248)
 - a. Example*: if there are total of Three Axillary HS3248 install on a campus there will be three HSM2204 install at the Main headend HS3248 control panel and one at each axillary control panel location for a total of six HSM2204 campus wide to allow interconnection control between main head end and all axillary control panels.
- B. System shall include the following features:
1. Real time clock and test timer.
 2. Battery charging circuit.
 3. Battery voltage supervision.
 4. Supervised automatic reset circuit breakers.
 5. Onboard warning buzzer and diagnostic LEOs.
 6. Automatic answer modem.
 7. Lightning and RFI protection.
 8. Central Station reporting format.
 9. Printer/CRT interface module for on-site serial data printer recording or CRT display of events.
 10. Quad serial output module for enhanced serial data interface capability for specific accessory modules and devices.
 11. Individual zone responses.
 12. Custom annunciator text.
 13. Audible alarm output, steady or pulsed.
 14. Automatic silencing.
 15. Attack-Resistant enclosure and lock meeting Underwriters Laboratory Local Burglary Requirements.
 16. A minimum of eight auxiliary form "C" dry contacts for a variety of programmable responses to alarm and trouble conditions.
 17. Transformer enclosure for internal mounting of Class 2 transformer.
 18. Two telephone numbers with selective signaling options.
 19. Individual zone responses.
 20. Automatic test reports.

2.03 BAR-CODE

Bar-code programmer for diagnostics and programming capability

2.04 RECEIVER

- A. Receiver shall be DSC Power PRO Series, UL listed for fire and intrusion detection.
- B. 18 VDC Power Adapter for main panel and power supplies Model: HS65WPSNA

- C. System shall contain 48 hours of standby power utilizing rechargeable sealed lead acid batteries and a battery charger.
- D. System shall be FCC approved for telephone connections.
- E. An alphanumeric LCD display shall indicate account number, area number, time, date, event, zone or point number, line or group number, status, and external devices.
- F. 24-hour clock and 128-year calendar.
- G. Forty-character line internal printer and interface capability with an external serial printer.
- H. Transmission verification appropriate with the format utilized.
- I. Storage of 249 separate events.
- J. Transmission format shall support the control panel.
- K. Turn the receiver over to the District for central station or campus monitoring.

2.05 REMOTE ACCOUNT MANAGER

- A. System shall be DSC Power PRO Series or equal with all equipment necessary for computerized access, programming, diagnostics, and remote control of the system. It shall be possible to remotely change passcodes, locate faults, shunt problem zones, arm and disarm the system, silence alarms, and control the auxiliary output contacts in the control panel.
- B. System shall permit remote diagnostics including utility and battery power conditions, phone line condition, event memory by zone, and current clock and calendar settings.
- C. System shall be 100% IBM compatible for use with personal computers.
- D. System shall include a plug-in modem and software necessary for a complete and operable installation. Furnish the District with a software license agreement for updated software enhancements as they develop.

2.06 KEYPADS

- A. Install all DSC LCD Keypads model HS2LCDPRO(RF)(P) in each exterior common area for each building to allow instructors disarming access at each building.
 - 1. Keypads shall be installed in a solid white polycarb enclosure and exterior thumb lock with "F" back-box Model number: STI-7511F-OW

2.07 MOTION SENSORS

- A. Provide a Dual technology PIR/Microwave 360° motion sensor(s) in each room having exterior doors, exterior glass, or skylights. Quantity of sensors in each room shall be as required to detect entry through exterior doors, exterior glass, or skylights.
 - 1. Motion detector should be installed center of room and sensitivity of microwave detection should be reduce to appropriate level for the room size which it is located and installed in according to manufacture specification.
 - 2. Sensor coverage patterns shall be as required for optimum coverage at each individual location. Sensor shall be adjustable Gimbal mounted with plate and outlet box. Provide an attack resistant enclosure DS AE774 at Multipurpose areas. Shall have a DSC expansion cabinet with sufficient amount of 2-amp Power supply bus extenders with four relays output model: HSM3204CX and eight zone expanders model: 3408 to supervise and power the cross connects from the field wire termination cabinet.

2.08 MAGNETIC SWITCH

Magnetic switch shall be fully concealed in the door frame, Admeco, Sentrol or equal.

2.09 INTRUSION DETECTION CABINETS

Each Intrusion Detection Cabinet shall be mounted and have a DSC expansion cabinet (with key lock) with sufficient amount of 2-amp Power supply bus extenders with four relays output model: HSM3204CX and eight zone expanders model: 3408 to supervise and power the cross connects from the field wire termination cabinet.

2.10 CABLING

Cabling shall be as required for system operation. All cablings shall be shielded.

PART 3 - EXECUTION

3.01 CONNECTIONS

All connections throughout the system shall be soldered, crimped by means of AMP lugs, fastened with screw type terminals, made by spring tension clip "punch block" terminals or make by standard plugs and receptacles. Each wire twisted pair or cable shall be tagged throughout the site with EZ Markers with the room number it serves. All conductors in terminal cabinets shall be carefully formed and harnessed in a workmanlike manner.

3.02 SYSTEM CABLING

All system cabling shall be installed in conduit except where wiring occurs above accessible ceilings. Wiring not in conduit shall be UL listed plenum-type cable. All wiring in walls shall be in conduit. All conduits shall be run concealed. Where architecture precludes concealed conduits, run conduits on top of beams or trusses and minimize the exposure to view. Identify on the Submittal Drawings all locations where conduits must run exposed.

3.03 MOTION SENSORS

Locate motion sensors to provide optimum coverage of the space and to avoid conflicts with the architectural aesthetics of the building. Submittal Drawings shall show the exact locations of all system sensors and keypads for approval by District's Maintenance Managers.

3.04 INSTALLATION

Coordinate concealed door switch installations with Finish Hardware Manufacturer.

3.05 SYSTEM PROGRAMMING

Provide all system programming as required by the District's Electronic Tech's Regional Maintenance Supervisor, including the necessary product handlers, so that all parameters are entered into the system and the annunciator displays a text, which is customized to the facility.

3.06 SYSTEM TESTING AND DOCUMENTATION

- A. Before the Contract shall be considered complete, the Contractor shall program the system per District Requirements and demonstrate the performance of the system in the presence of the District. The Contractor shall provide all test and reception gear required to prove the performance as outlined.

- B. Actuate motion sensing devices and verify that the system performs as specified.
- C. The communication loops shall be opened in at least two locations per building to check for the presence of correct supervisory circuitry.
- D. When the testing has been completed to the satisfaction of both Contractor's Job Foreman and the Representatives of the Manufacturer and the DSA Inspector, a notarized letter co-signed by each attesting to the satisfactory completion of said testing shall be provided by the Contractor and forwarded to the Architect.

3.07 TRAINING

Provide a minimum of two 4-hour periods to instruct District Personnel in proper operation of all systems. Instruction to be arranged in advance at the District's convenience and conducted during normal working hours from 6:30 a.m. to 3:00 p.m. Monday through Friday. Instructors and participants shall sign an attendance sheet of which a copy is to be given to the District Authorized Representative during closeout documentation. The first instructional period shall be held prior to final acceptance of the systems. Instructional training shall be done at the project site and shall be conducted by factory-trained Technical Personnel. Furnish the District with an electronic audio/visual recording of the first instruction session on a DVD. The second instructional period shall be within a period of 1-year after final acceptance of the systems, upon request of the District, during normal working hours 6:30 a.m. to 3:00 p.m., Monday through Friday.

END OF SECTION 28 31 00

021721/212276

SECTION 28 46 20
FIRE DETECTION AND ALARM

PART 1 - GENERAL

1.01 SCOPE

- A. Work Included: All labor, materials, appliances, tools, equipment necessary for and incidental to performing all operations in connection with furnishing, delivery and installation of the work of this Section, complete, as shown on the Drawings and/or specified herein. Work includes, but is not necessarily limited to the following:
 - 1. Examine all other Specifications Sections and Drawings for related work required to be included as work under Division 26, 27, and 28.
 - 2. General Provisions and Requirements for electrical work.
- B. This Specification provides the Minimum Requirements for the Fire Alarm and Detection System. The system shall include, but not limited to all equipment, materials, labor, documentation and services necessary to furnish and install a complete, operational system to include but not limited to the following functions:
 - 1. Smoke and fire detection.
 - 2. Sprinkler suppression system monitoring and control.
 - 3. Off-premises notification.
 - 4. Door release.
 - 5. Mass Notification system.
 - 6. One-way voice communication notification system.
 - 7. Two-way voice communication system.

1.02 SUBMITTALS (ADDITIONAL REQUIREMENTS)

- A. Submit eight copies of the following to the Architect for approval.
 - 1. A listing of all fire alarm components and equipment including the California State Fire Marshal (CSFM) listing numbers.
 - 2. CSFM listing sheets of all devices being used.
 - 3. Manufacturers' standard catalog data for fire alarm components.
 - a. The submittal shall be arranged in the order of the Specification and shall list the Specification paragraph number, the name, the proposed model and Manufacturer for each item as well as a reference indicating the specific piece of data which can be easily located in the brochure.
 - b. The Manufacturers' data sheets shall be marked to indicate the specific item being proposed in cases where the sheet covers several types or sizes of item. The data sheet shall completely describe the proposed item.
 - c. Where modification to the equipment is necessary to meet the Operational Requirements of the Contract Documents and the data sheets shall include complete Mechanical and Electrical Shop Drawings detailing the modification.

4. A listing of the outlet rough-in needed for every device and equipment item. The applicable symbol which illustrates that rough-in item on the job plans shall be drawn on the proposal, opposite the description of the rough-in to facilitate locating the data by Field Personnel.
5. Elevation and dimensional information.

1.03 APPLICABLE STANDARDS

- A. The Equipment shall be listed, labeled, and approved for the application shown in Contract Documents, as fire alarm equipment complying with the following Requirements:
 1. The California State Fire Marshal, California Building Code (CBC) and California Fire Code (CFC)
 - a. 2019 Building Standards Administrative Code, Part 1, Title 24 C.C.R.
 - b. 2019 California Building Code (CBC), Part 2, Title 24 C.C.R.
 - c. 2019 California Electrical Code (CEC), Part 3, Title 24 C.C.R.
 - d. 2019 California Mechanical Code (CMC), Part 4, Title 24 C.C.R.
 - e. 2019 California Plumbing Code (CPC), Part 5, Title 24 C.C.R.
 - f. 2019 California Fire Code (CFC), Part 9, Title 24, C.C.R.
 - g. 2019 California Referenced Standards Code, Part 12, Title 24, C.C.R.
 - h. 2019 Title 19, C.C.R., Public Safety, State Fire Marshal Regulations.
 2. National Fire Protection Agency (NFPA)
 - a. NFPA 72, National Fire Alarm Code.
 - b. NFPA 90A, installation of air conditioning and ventilating systems.
 - c. NFPA 70, National Electrical Code (N.E.C.), and N.E.C. Article 760.
 - d. NFPA 101, Life Safety Code.
 3. The fire alarm system shall conform to the applicable Standards and Guides referenced in CBC Chapter 60.
- B. Written Certification by the Fire Alarm Equipment Manufacturer shall be submitted to the Architect, stating that the system and its component parts are listed and approved by the California State Fire Marshal and the installation has been tested, is operational and conforms to the Requirements as set forth in Part 3, Article 24, Title 19, California Code of Regulations.

1.04 EQUIPMENT AND INSTALLING QUALIFICATIONS

- A. The Equipment shall be manufactured by Notifier or approved equal.
- B. The Specification is based on the equipment of Manufacturers who have been approved by the District and the Manufacturers herein named shall be considered as meeting the Requirements of this Specification. For all items which are identified by part number and Manufacturer the Performance Specifications which are published in the most recent Manufacturer's data sheets available at the time of bidding this project shall be applicable to the present work as though fully written out herein.
- C. All Equipment shall conform to all local applicable Codes and Ordinances and shall be listed by Underwriters Laboratories.

- D. To Qualify as an acceptable Bidder, whether the bid is submitted to the District, his Agent, a General Contractor or a Sub-Contractor, the System Bidder or Contractor shall be qualified Fire Alarm Contractor and shall hold a valid C10 License issued by the Contractors State License Board of California. The System Bidder or Contractor shall hereinafter be referred to as the Contractor. The Contractor shall hold all other licenses required by the legally constituted Authorities having jurisdiction over the work. The Contractor shall be the Factory Authorized Distributor for the branch of equipment offered and shall have been engaged in the business of supplying and installing the specified type of system for at least 5-years. The Contractor shall maintain a fully equipped service organization capable of furnishing adequate repair service to the equipment. The Contractor shall be financially able to provide a performance bond covering the work and the guarantee described. The Contractor shall provide that bond if requested.
- E. Installation Certification
 - 1. Work and material for cables, cable terminations and related components shall be performed by certified Installers. The installer shall be certified by the respective Product Manufacturers.
 - 2. The Manufacturers of the indicated work and material shall provide an Installer education/training and certification program for the supplied products.
 - 3. The Installers performing the Contract work for the indicated products shall have attended and successfully completed each of the respective Manufacturer's installation training education programs for the specified products.
 - 4. Submit six copies of the Manufacturer's certifications for each Installer performing the work. The submittal shall be approved prior to initiating any related Contract Work.
 - 5. Contract material installed, and work performed by Installers not complying with these Requirements shall be removed. Removal of work and material not in compliance with these Requirements shall done at the Contractors' expense, without any additional cost to the Contract and without any additional Contract completion due date extensions. New material and work required to replace the non-compiling removed work and material shall be provided at the Contractors' expense, without any additional cost to the Contract and without any additional Contract completion due date extensions.

PART 2 - PRODUCTS

2.01 GENERAL SYSTEM OPERATION

- A. System shall be microprocessor-based, addressable, and power-limited with Class B supervised circuits, one-way and two-way emergency audio communications.
 - 1. The microprocessor shall execute all supervisory and control programming to detect, report the failure or disconnection of any system module or peripheral device and initiate programmed control sequences. An isolated supervision "watchdog" circuit shall monitor the microprocessor and, upon failure, shall activate the system trouble circuits.
 - 2. The automatic fire detection and alarm system shall consist of main control panel, transponder panel(s), notification alarm devices, remote annunciator, automatic detection devices, manual stations, printer, and CRT/keyboard, installed and wired in accordance with the Drawings and shall function as specified herein.

3. The system shall be programmable in the field, by a non-computer trained person. All programmed information shall be stored in non-volatile memory.
 4. The system shall operate both addressable and non-addressable ionization, thermal and photoelectric detecting devices, manual stations, water-flow switches, and external control modules.
 5. The control panel shall provide power, annunciation, supervision and control for the fire detection and alarm system. The system shall be designed such that alarm indications override trouble and control conditions.
 6. External circuit supervision shall not require additional wires other than the pair used for detection or alarm (only two wires shall be used from the control panel to each loop of initiating devices and two wires for the notification alarm devices). These two wires shall provide both supervision and notification alarm signals. There shall be no loss of supervision for Class "B" wired addressable devices. Class "A" supervision may be provided by adding an additional pair of wires.
- B. Alarm Conditions
1. Actuation of any manual or automatic alarm initiating device, connected to the system shall cause the following automatic functions.
 - a. All notification alarm signaling units shall activate continuously. Audible notification alarms shall sound the California State Coded Signal.
 - b. The respective zone alarm lamp or annunciator alphanumeric readout on the central control panel, and remote annunciator panel, shall be activated.
 - c. Activate the Digital Alarm Communicator system.
 2. Actuation of HVAC air duct smoke detectors shall stop the designated fans and motors in the building's air distribution system.
 3. Actuation of smoke detectors on either side of smoke doors shall energize the release mechanism on the smoke door causing the door to close.
 4. Notification alarm signal duration shall be capable of continuous sounding or adjustable from three to 10-minutes.
 5. Perform any additional functions as specified herein or shown on the Drawings.
- C. Trouble Condition
1. A single open or single trouble condition in a manual or automatic fire initiating wiring circuit shall activate the respective zone trouble lamp or annunciator readout on the fire alarm control panel and sound a trouble signal at the control panel.
 2. A single open or single trouble condition in the notification alarm signaling wiring circuit shall activate the trouble lamp or annunciator readout in the control panel and sound a trouble signal at the control panel.
 3. 120 volt AC normal power shall be monitored with indication by a "power on" lamp. Upon normal power outage, the system shall activate power trouble condition lamp or annunciator readout and indicate a trouble condition.
 4. The control panel shall monitor the standby batteries and, upon a low battery condition, activate the low battery lamp or annunciator readout and indicate a trouble condition.

5. System ground detection shall be provided for the entire system. Upon ground detection, activate the ground detection lamp or annunciator readout and indicate a trouble condition.
- D. Control Panels employing alphanumeric readouts shall display the trouble condition along with a prompt to review the list chronologically. The end of the list shall be indicated.

2.02 FIRE ALARM CONTROL PANEL

A. General

1. The fire alarm control panel shall be software programmable, microprocessor controlled, solid state, electronic integrated system. The panel shall be the product of one Manufacturer. The control panel shall provide power, annunciation, supervision and control for the detection and alarm system. The detection system shall remain 100% operational, responding to an alarm condition while in the routine maintenance mode.
2. Addressable detection and control devices shall be individually identified by the system, and any quantity of addressable detection devices shall be in alarm and any quantity of addressable control units shall be operable at any time up to the total number connected to the system.
3. The microprocessor shall access the system program, which is stored in non-volatile programmable memory, for all control-by-event (CBE) functions. The system program shall not be lost upon failure of both primary and secondary power. Volatile memory shall not be acceptable.
4. A means shall be provided for acknowledging each abnormal condition. Each activation of the appropriate acknowledge button shall sequentially acknowledge every point in the system. After all the points have been acknowledged, the LEDs shall glow steady and the panel audible signal will be silenced. The total number of alarms, supervisory, and trouble conditions shall be displayed along with a prompt to review each list chronologically. The end of the list shall be so indicated.
5. An alphanumeric annunciator readout shall indicate on the control panel the activation by type, loop, and address of the specific device, sub-loop or alarm/monitor/control points via an alphanumeric display. An audible alert shall sound at the control panel and an alarm light shall flash.
6. If the microprocessor fails, the system shall executive a default signaling program. This program shall enable the control panel to sound the audible signals and summon the Fire Department. In addition, a red LED shall light to indicate the communication loop wherein the alarm originated. Inability of the system to sound signals or summon the Fire Department during microprocessor failure shall not be acceptable.
7. Protected access to the system controls shall be provided to allow the user/operator access to the following system functions:
 - a. Status of all addressable points.
 - b. Status of all events logged.
 - c. Set/change the real-time clock and date.
 - d. Perform an operational manual test of the system from the control panel, including actuation of any initiating device and trouble circuit without alarming the remote

central station. The panel shall automatically return to normal mode in the event the panel remains unattended in the service mode.

- e. Retrieve from event log the last 300 alarms, or control points and 300 trouble conditions.
 8. Individual input (monitor) and output (control) device addressability shall all be performed on the same pair of wires. Wiring shall be Class "A" or "B". When Class "B" wiring is used, no special wiring sequence shall be required on addressable device circuits. An unlimited number of wiring branches shall be permitted with no loss of supervision.
 9. A minimum of 25% addressable monitor, trouble and control points shall be provided.
- B. Cabinet
1. A metal tamper resistant cabinet shall contain the control panel components. Panel shall be surface or flush mounting as indicated on the Drawings. Provide a full height tamper resistant hinged locking cabinet door. The door shall have transparent, high impact windows to allow visual observation of all indicators and switches without opening the panel door.
 2. "In-out" circuit conductors shall terminate on numbered screw-type terminals.
 3. All groups of circuits or common equipment shall be clearly marked and shall be expandable by inserting interchangeable units.
- C. The Control Panel shall provide positive protection against the fire alarm system inadvertently being left in a non-operating status. The alarm system shall automatically restore and resound alarms and trouble signals, if subsequent alarm initiating or trouble signals are received under any of the following conditions:
1. After the alarm or trouble silence switch have been activated.
 2. Prior to resetting system after previous alarm or trouble conditions.
- D. The System indicating, and operational control devices shall be mounted on the control panel face behind the panel door and shall provide the following minimum functions:
1. Individual visual indicating pilot lights annunciator or alphanumeric readout to monitor the following alarm system conditions:
 - a. Input power.
 - b. System common alarm.
 - c. System common trouble.
 - d. Alarm or trouble signal silenced.
 - e. Ground fault.
 - f. Battery condition.
 - g. Each individual alarm, control or initiating zone-activation.
 - h. Each individual alarm, control or notification zone-trouble.
 - i. Report, by specific device number, any device removed from an addressable initiating circuit, all other devices shall continue to function.
 2. Manual control switches to allow the following system controls:
 - a. Alarm silence.

- b. Trouble silence.
 - c. Test all indicating pilot lights and readouts.
 - d. System reset, including remote devices connected to the alarm panel.
 - e. Alarm test to initiate an alarm condition from the control panel.
 - f. Alarm disconnect for system testing without activating the Digital Alarm Communicator system.
 - g. Changing the status of configured circuits (arming or disarming and changing status of relays). If any change in status degrades system operation as configured, a trouble condition shall be reported and remain until system operation again meets configured status.
 - h. Perform multiple operations at the same time. These operations shall include but not be limited to timed functions and multiple configured sequences.
- E. Alarm Initiating Zone Modules.
- 1. Shall supervise and accept remote alarm actuating device input signals. An alphanumeric readout shall indicate separate zone alarm and trouble indicators for each zone.
 - 2. Zones shall be compatible and designed to operate with the connected initiating devices either addressable or non-addressable type.
 - 3. A spare double throw set of software programmable auxiliary alarm relay contacts shall be provided for control of remote devices for each zone. Contacts shall be rated 120-volt 60Hz 3-amp.
 - 4. Each device on the system shall report as its own unique address.
- F. Notification Alarm Signal Control.
- 1. Shall supervise and activate remote notification alarm devices.
 - 2. Notification alarm shall be compatible and designed to properly operate with the connected audio and visual notification alarm devices, with no signal degradation.
 - 3. The notification alarm shall provide group notification signal control of all notification zones.
 - 4. The alarm modules shall be field resettable to provide either continuous or coded notification alarm signals. The coded alarm signal shall provide an intermittent "on-off" pulsed sound activation of audible notification alarm devices.
 - 5. A notification alarm circuit trouble indicating readout shall be provided for each notification zone.
- G. Audio
- The system shall be capable of delivering multi-channel audio messages simultaneously over copper and/or fiber media. All audio messages and live pages shall originate at the one-way audio control unit. The one-way audio control unit shall store pre-recorded audio messages digitally. These messages shall be automatically directed to various areas in a facility under program control. The system shall support remote cabinets with zoned amplifiers to receive, amplify and send messages through speakers over supervised circuits. The one-way emergency audio control shall provide control switches to direct paging messages as follows: "All Call" to direct the page messages to all areas in the facility, overriding all other messages and tones.

"Page to Evacuation Area" to direct the message to the evacuation area(s), overriding all other messages and tones.

"Page to Alert Area" to direct page messages to the area(s) receiving the alert message and tones, overriding all other messages and tones.

"Page to Balance Building" to direct page messages to the areas) in the facility NOT receiving either the evacuation area or alert area messages.

"Page by Phone" switch to select the Fire Fighters telephone system as the source for paging. The system shall be capable of delivering multiple audio messages simultaneously over copper and/or fiber media. All audio messages and live pages shall originate at the one-way emergency audio control unit. The one-way emergency audio control unit shall store pre-recorded audio messages digitally. These messages shall automatically direct to various areas in a facility under program control. The system shall support remote panels with zoned amplifiers to receive, amplify, and distribute messages through speakers over supervised circuits.

The two-way voice communications control unit shall provide two-way communications between remotely located phones and the command center. The control unit shall provide the ability to individually select and display each two-way voice communication circuit support up to five remote telephones in simultaneous two-way voice communications.

Audio Amplifiers (Multi-Channel)

Provide one 20-watt audio amplifier per paging zone. There will be a total of two 20-watt amplifiers (one per floor). The system software shall be capable of selecting the required audio source signal for amplification. To enhance system survivability, each audio amplifier shall automatically provide a local 3-3-3 1000Hz temporal pattern output upon loss of the audio communications with the one-way audio control unit, during an alarm condition. Audio amplifiers shall be power limited and protected from short circuits conditions on the audio circuit wiring. Each amplifier output shall include a dedicated, selectable 25/70 Vrms output. Provide a standby audio amplifier that will automatically sense the failure of a primary amplifier and replace the function of the failed amplifier.

- H. Automatic Ground Detection shall detect either positive or negative voltages when earth connections of 50,000 OHMS or less occur and activate the ground trouble signal.
 - 1. A Ground Fault Code shall provide indication of either a positive or negative ground fault and shall operate the general trouble devices as specified herein but shall not cause an alarm to be sounded.
 - 2. A short circuit error message shall be a standard feature of the fire alarm control panel. Each communication loop shall be monitored for short circuits and shall have a distinctive error message for visual indication of circuits and operating trouble devices as specified herein but shall not cause an alarm to be sounded.
- I. Power Supply
 - 1. The dedicated power supply shall be adequately sized to properly operate the equipment, including remotely connected, spare and future indicated equipment with all alarm devices in alarm condition. Provide 20% spare power supply capacity for future expansion. Provide transfer modules and multiple power supplies as required for proper operation.
 - 2. Input voltage 120/240 volt or 120/208-volt 60Hz AC.
 - 3. Surge voltage protection on the input and output phases of the power supply shall be provided.

4. Supervised voltage types (i.e., 120-volt 60Hz AC, 24-volt AC, 24-volt D.C., etc.) required by special connected equipment shall be supplied, including but not limited to:
 - a. Alarm initiating devices.
 - b. Notification alarm devices.
 - c. Control and annunciator panels.
 - d. Fire and smoke dampers.
 5. A solid-state power transfer circuit shall provide (UPS) Uninterrupted Power Supply between internal standby power and line power automatically and instantaneously if normal power fails or falls below 15% of normal ("brown out" conditions).
 6. Individual circuit fuses shall be provided for smoke alarm detector power, main power supply notification circuits, battery standby power, and auxiliary output.
 7. Provide lock-on device on each power supply dedicated branch circuit breaker at panel.
- J. Battery Back-Up Operation
1. Internal batteries and battery power supplies shall be provided to allow 60-hours continuous automatic normal operation of the entire control panel and fire alarm system after the failure of the incoming utility power. Sufficient battery capacity shall remain at the end of 60-hour period to provide ten minutes of continuous operation of all connected notification alarm devices.
 2. Batteries shall be maintenance free, sealed, lead-acid or lead calcium or gelled electrolyte type rated 25% larger than required to provide power for the entire system upon loss of normal 120VAC power for a period of 60-hours with 15-minutes of alarm signaling at the end of this 60-hour period.
 3. The battery charger shall be automatic, dual rate with capacity to recharge completely discharged batteries in 18 hours. Charger shall be temperature compensated.
- K. Lightning and Surge Protection shall be a standard feature of the fire alarm control panel and shall be incorporated in the power supply circuit, common control circuits, signal circuits, and telephone line circuit.
- L. Circuitry shall be provided in the control panel to permit transmission of trouble and alarm signals over leased or privately owned telephone cables to a remote receiving panel. A reverse polarity or a master box circuit as required shall be provided in the control panel. There shall be a supervised disconnect switch to allow testing of the fire alarm signal without transmitting an alarm signal to the central station.
- M. The Alphanumeric Annunciator (printer and CRT/keyboard) shall list upon request:
1. Alarms with time, date and location.
 2. Troubles with time, date and location.
 3. Status of output functions, "on" or "off".
 4. Sensitivity of addressable smoke detectors.
 5. Detection device number, type and location.
 6. Status of remote relays, "on" or "off".
 7. Acknowledgment time and date.
 8. Signal silence time and date.

9. Reset time and date.
- N. The System shall also provide the following:
1. Counting the number of addressable detectors within a "zone".
 2. Which are in alarm.
 3. Counting "zones" which are in alarm.
 4. Counting the number of addressable detectors which are in alarm.
 5. Alarm on the system.
 6. Differentiating among types of addressable detectors such as smoke detectors, manual stations, water-flow switches, thermal detectors.
 7. Assigning priorities to types of detectors, zones or groups of detectors.
 8. Cross-zoning.
- O. Control Functions
1. Control functions shall be assigned on the basis of multi-relational system initiation patterns of detection devices including full logic element equations using as "anding" zones, counting zones, counting devices, "anding" groups, conditional "if", "then", "or" programming and "anding" types of detection devices.
 2. Control functions shall be assigned on the basis of, cycle, delay, count, time of day, day of week, day of month and with a holiday schedule of up to 30-holidays per year. Each addressable detection device shall report its condition to the system control unit not less than every 4-seconds in a manner such that failure of the connections to the internal electronics of the device will result in a trouble signal which identifies the specific device involved.
 3. The system shall be field programmable for the response of control points to monitored devices.
 4. The operating software program shall provide programmable control for the Event-Initiated-Programs (E.I.P.) which shall allow automatic operation of system control points in the event of an alarm condition. To program these E.I.P.s, the system shall use a specifically designed user-friendly programming language, which shall not require a knowledge of computer programming to learn and understand.
 5. The operating software shall support the following additional capabilities:
 - a. Three levels of designated and unique Priority Alarms for each point.
 - b. Designated "Sense Mode" for status interpretation for each point.
 - c. Designated Print/No Print/Vectoring Mode for each point.
 6. The input statement defines the conditions required to activate the associated output statement. The input statement shall consist of single or multiple monitor point status, subroutine status, time comparison and the utilization of AND, OR, NOT, COUNT, and DELAY logic functions.
 7. The output statement defines the action to be taken by the control panel. The output statement shall consist of activation/deactivation of single or multiple control functions, subroutines, and remote Annunciator status LED's. Output statements shall also include the "Alert" messages.

8. The software shall provide an "alert" message, unique to each point in the system, which will provide specific instructions for the operator on duty. These messages shall be up to five lines with up to seventy characters in each line. Each system monitor point shall have five specific alert messages when in alarm. Control points shall also be assigned alert messages.
9. The hardware and software shall have the capacity to accept up to 64-independent programs. Each program shall have "Edit" or "No Edit" capability. Each program shall be written in an equation format comparable to ladder-logic equations. The Equations shall consist of an input and an output statement.
10. Provide initial programming services for coding, loading, and debugging the initial District specified programs, as part of the Contract.
11. Programming Command Definition
 - a. Timing command shall provide time delay and time control functions based on internal clock/calendar by time of day; day of week; day of month; month in year.
 - b. Count command shall provide a specific number of events to occur before a control action is initiated.
 - c. Pulse command shall provide on control for a specific period of time.
 - d. Cycle command shall provide on-off control for preset periods of time.
 - e. Print command shall provide printing of specified information after an event occurs.

2.03 FIRE ALARM DIGITAL ALARM COMMUNICATOR TRANSMITTER

- A. Enclosure shall be red.
- B. Panel shall be solid state with eight zones for off premise monitoring of the fire alarm control panel.
- C. System shall monitor alarm and trouble conditions. System shall be power limited.
- D. System shall include dual telephone line switcher for central station reporting. Telephone lines shall be supervised.
- E. System shall include dual battery harness, batteries, and battery charger.
- F. System shall be UL listed for central station fire signaling systems (NFPA 71).
- G. System shall be California State Fire Marshal approved for central station reporting.
- H. System shall be Radionics D8112FA Series or Simplex 5071 Series. System shall be approved for connection to the fire alarm control panel.
- I. Verify Specific Requirements with District and central station prior to submittals.

2.04 MANUALLY ACTIVATED ALARM INITIATING DEVICES

- A. An Electronic, Digital Multiplex, Addressable Module shall be incorporated into each device. The module shall communicate the status and trouble condition of each device with a unique address code. The module shall communicate with and be supervised and monitored by the fire alarm control panel.
- B. Devices shall be suitable for use on a Class "B", 2-wire supervised alarm initiating circuit.
- C. Numbered Screw Type Terminals shall be provided for "in-out" connections of the alarm circuit wiring.

- D. The Face of the Station shall have lettering indicating "FIRE" and operational instructions. Stations shall be tamper resistant, semi-flush mounting.
- E. Auxiliary Spare Switch Contact shall be provided for control of remote devices rated 120 volts - 60Hz, AC - 3AMP minimum.
- F. Stations shall provide visual indication the station has been activated. A key (and/or special tool) shall be required to gain access into the station to reset the station after being activated.
- G. Stations shall be "non-break-glass" type.
- H. RF and Transient Filtering shall be provided in the device electronics.
- I. Pull Stations shall be non-coded double action, requiring a two-District manual "pulling" actions to initiate the fire alarm system.
- J. Stations Installed Outdoors shall be weather resistant construction, double action to activate the pull station.

2.05 AUTOMATIC ALARM INITIATING DEVICES

A. General

- 1. An electronic digital, multiplex, addressable module shall be incorporated into each device. The module shall communicate the status and trouble condition of each device with a unique address code. The module shall communicate with and be supervised and monitored by the fire alarm control panel.
- 2. Devices shall be suitable for use on a Class "B", 2-wire supervised alarm initiating circuit. Where initiating devices are shown connected to an existing system, devices shall operate on 2 or 4-wire circuits plus, 2-wire power circuit as required by the existing equipment.
- 3. Numbered screw type terminals shall be provided for "in-out" connectors of the alarm circuit wiring.
- 4. Auxiliary double throw spare relay contact shall be provided for activation of remote rated devices 120-volt 60Hz, AC, 1-amp minimum.
- 5. RF and transient filtering shall be provided in the initiating device electronics.
- 6. Initiating devices shall be reset from the control panel and shall not require individual resetting.

B. Smoke Detector

- 1. Detectors shall comply with UL Standard 268, 167 and 168, and shall use solid state electronic circuits throughout.
- 2. The smoke detector shall operate on a total of two circuit wires. Alarm signaling and detector power shall use the same conductors. Detector sensitivity shall be factory set at 1.5%. Provide testing provisions in accordance with CFC 907.9.3 – 907.9.4.1, NFPA72.
- 3. A fine mesh insect screen shall be provided on all detector openings.
- 4. The detector shall lock-in on alarm and shall provide a visual alarm/trouble indicator light. An electromechanical test feature shall provide functional testing of the unit without smoke.

5. The detector shall also incorporate a fixed temperature heat detector rated at 135 degrees F. The heat detector shall operate the alarm circuit and alarm/trouble light.
 - a. Photo electric type smoke detectors shall employ a Light Emitting Diode (LED) as the detector light source, activated by the presence of combustion smoke products. Failure of the LED shall activate the alarm/trouble light on the detector.
 - b. Ionization type smoke detector shall employ the triple chamber (dual chamber) ionization principle, activated by the presence of combustion products. The ionization chamber shall be RF shielded.
 - c. Air duct smoke detector photo electric or ionization type for installation on a mechanical air duct. Two air tubes shall extend into the air duct. The sampling tube shall extend across the entire width of the air duct. The second tube shall allow air to escape back into the duct.
- C. Fire Detector – Heat
1. Heat detectors shall be dual action electro-thermostatic combination rate of temperature rise and fixed temperature operation. An indicator shall be visible when detector has activated.
 2. The rate of rise element shall be self-restoring, after activation.
 3. The fixed temperature unit shall be set at 136 degrees F (190 degrees F for high temperature areas i.e., over 110 degrees F).
 4. Provide a wire guard cover for the detector.
- D. Fire Sprinkler Water Flow Detector.
1. Vane-type water flow detectors shall be provided on the sprinkler system piping as shown on the Drawings. Detectors shall be designed for mounting on either vertical or horizontal piping but shall not be mounted in a fitting or within 12 inches of any fitting that changes the direction of water flow.
 2. The detectors shall have a sensitivity setting to signal any flow of water that equals or exceeds the discharge from one sprinkler head.
 3. Detector switch mechanisms shall incorporate an instantly recycling pneumatic retard element with an adjustable range of 0 to 70 seconds. Switches shall have a minimum rated capacity of 7-amp 125-volt AC - .25 amp 24-volt D.C. A D.P.D.T. switch shall be actuated by a polyethylene vane extending into the waterway of the piping.
 4. Detectors shall be of weatherproof, dust tight construction and shall provide a ¾-inch conduit entrance. Detector shall be finished in red baked enamel.
 5. Flow switch shall be sized to match the fire sprinkler riser pipe diameter.
- E. Fire Sprinkler Valve Tamper Switch
1. Tamper switch shall monitor the position of the fire sprinkler shut-off valve. Operation of the valve shall activate the switch and activate a trouble alarm.

2.06 NOTIFICATION ALARM DEVICES

A. General

1. Notification alarm devices shall activate automatically from the control panel. Devices shall operate on a Class "B" (Style Y), 2-wire supervised alarm notification circuit. Series wired alarm devices shall not be used.
2. Numbered screw type terminals shall be provided for "in-out" connections of the alarm circuit wiring.
3. Devices shall be installed in a box, 3½-inches deep maximum, flush mounting unless indicated otherwise on the Drawings. Size as required for the alarm indicating device and wiring connections. Provide a trim ring and metal grill cover assembly. Cover assembly shall be a minimum of 1/16-inch minimum thick flat stainless steel or aluminum. Finish color as selected by Architect. The word "fire" shall appear on the grill minimum ½-inch letters. The grill shall be attached with screws to the box.
4. Each audible notification visual devices shall incorporate a visual alarm indicator. The visual alarm indicating device shall be an integral part of the audible alarm box assembly.
5. Audible notification device and visual notification devices shall be connected to separate notification alarm signal circuits. Do not connect these devices to the same circuit conductors.

B. Notification Appliances

1. Speakers

Low Profile Speaker

Provide low profile wall mount speakers at the locations shown on the Drawings. The low-profile speaker shall not extend more than 1-inch (2.5cm) past the finished wall surface and provide a switch selectable audible output of 2W (90dBA), 1W (87dBA), ½W (84dBA), or ¼W (81dBA) at 10 feet when measured in reverberation room per UL-464. Wattage setting shall be visible with the cover installed. When the cover is installed, no mounting hardware shall be visible. In and out screw terminals shall be provided for all wiring. The low-profile speaker shall mount in a North American 4-inches x 2⅝-inches square electrical box, without trims or extension rings.

2. Speaker-Ceiling Mount-8-inches

Provide 8-inches ceiling mounted speakers at the locations shown on the Drawings. In and out screw terminals shall be provided for wiring. Speaker baffles shall be round or square steel with white finish as required. Provide square surface mount boxes with matching finish where required. Speakers shall provide ½W, 1W, 2W, and 4W power taps for use with 25V or 70V systems. At the 4-watt setting, the speaker shall provide a 94-dBA sound output a frequency of 1000Hz when measured in an anechoic chamber at 10 feet.

3. Speaker-Cone-4-inches

Provide 4-inches white speakers at the locations shown on the Drawings. Speakers shall have a 4-inches Mylar cone, paper cones are not acceptable. The rear of the speakers shall be completely sealed protecting the cone during and after installation. In and out screw terminals shall be provided for wiring. Speakers shall provide ¼W, ½W, 1W, and 2W power taps for use with 25V or 70V systems. At the 2-watt setting, the speaker shall

provide a 90-dBA sound output over a frequency range of 400-4000Hz when measured in reverberation room per UL-1480.

4. Speaker-Reentrant Surface

Provide 4-inches surface re-entrant speakers at the locations shown on the Drawings. Speakers shall provide 2W, 4W, 8W, and 15W power taps for use with 25V or 70V systems. The re-entrant speakers shall utilize a high efficiency compression driver. Cone type drivers are not acceptable. At the 15-watt setting, the speaker shall provide a 102 dBA sound output over a frequency range of 400-4000 Hz when measured in reverberation room per UL-1480. Weatherproof boxes shall be provided for outdoor mounting.

5. Speaker-Strobes

Low Profile Speaker-Strobe

Provide low profile wall mount speaker/strobes at the locations shown on the Drawings. The low-profile speaker/strobe shall not extend more than 1-inch (2.5cm) past the finished wall surface and provide a switch selectable audible output of 2W (90dBA), 1W (87dBA), ½W (84dBA), or ¼W (81dBA) at 10 feet when measured in reverberation room per UL-464.

Strobes shall provide synchronized flash output that shall be switch selectable for output values of 15cd, 30cd, 75cd and 110cd. Wattage and candela settings shall be visible with the cover installed. When the cover is installed, no mounting hardware shall be visible. In and out screw terminals shall be provided for all wiring. The low-profile speaker/strobes shall mount in a North American 4-inches x 2 1/8-inches square electrical box, without trims or extension rings.

6. Speaker-Strobe 4-inches

Provide 4-inches red speakers/strobes at the locations shown on the Drawings. Speakers shall have a 4-inch Mylar cone, paper cones are not acceptable. The rear of the speakers shall be completely sealed protecting the cone during and after installation. In and out screw terminals shall be provided for wiring. Speakers shall provide ¼W, ½W, 1W, and 2W power taps for use with 25V or 70V systems. At the 2-watt setting, the speaker shall provide an 87 dBA sound output over a frequency range of 400-4000Hz when measured in reverberation room per UL-1480. Strobes shall provide synchronized flash. Strobe output shall be determined as required by its specific location and application from a family of 15/75cd, 30cd, and 110cd devices.

7. Speaker-Strobe Ceiling 8-inches

Provide 8-inches ceiling mounted speaker/strobes at the locations shown on the Drawings. In and out screw terminals shall be provided for wiring. Speaker baffles shall be round or square, steel with white finish as required. Provide square surface mount boxes with matching white finish as required. Speakers shall provide ½w, 1w, 2w, and 4W power taps for use with 25V or 70V systems. At the 4-watt setting, the speaker shall provide a 94 dBA sound output a frequency of 1000Hz when measured in an anechoic chamber at 10 feet. Strobes shall provide synchronized flash outputs. Strobe output shall be determined as required by its specific location and application from a family of 15cd, 30cd, 75cd, and 110cd devices.

8. Speaker-Strobe Re-entrant

Provide 4-inches red re-entrant speaker/strobes at the locations shown on the Drawings. Weatherproof boxes shall be provided for outdoor mounting. Speakers shall provide 2W, 4W, 8W, and 15W power taps for use with 25V or 70V systems. The re-entrant speakers shall utilize a high efficiency compression driver. Cone type drivers are not acceptable. At the 15-watt setting, the speaker shall provide a 102dBA sound output over a frequency range of 400-4000Hz when measured in reverberation room per UL-1480. Strobes shall provide synchronized flash. Strobe output shall be determined as required by its specific location and application from a family of 15cd, 30cd, 75cd, and 110cd devices.

C. Visual Alarm Indicator

1. Lamp/Strobe internally illuminated projecting lens assembly, with flasher system. Unit shall flash on and off to provide visual indicating of fire alarm.
2. The word "fire" shall appear on the lens or lens plate.
3. Flash rate, one flash per second, with a flash duration of approximately 0.001 second, flash rate independent of audible device.
4. Light source, Xenon high intensity flash strobe tube white/clear color.
5. Strobe shall have a minimum output of 75 candelas with a maximum flash intensity of 120 candelas.
6. Strobe shall comply with NFPA Requirements.

2.07 REMOTE FIRE ALARM ANNUNCIATOR

A. General

1. The annunciator panel shall be powered and operated from the fire alarm control panel. "In-out" circuit conductors shall terminate on numbered screw-type terminals.
 2. A metal tamper resistant weatherproof cabinet shall contain the annunciator components. The panel shall be surface or flush mounted as indicated on the Drawings. Provide a full height tamper resistant, hinged locking cabinet door. Door shall have transparent high impact windows to allow visual observation of all indicators and switches.
 3. An electronic digital, multiplex, addressable module shall be incorporated into the annunciator. The module shall communicate the status and trouble condition of each device with a unique address code. The module shall communicate with and be supervised and monitored by the fire alarm control panel.
- B. Each Alarm Initiating Zone (including spares) shall be individually annunciated in the annunciator panel.
- C. A Common Fire Trouble Alarm shall be annunciated in the annunciator panel from the fire alarm control panel.
- D. Annunciator Lamp Circuits shall be automatically supervised. Provide lamp test switch in the annunciator panel.
- E. An Audible Alarm/Trouble Buzzer with silence switch and automatic resound for subsequent alarm/trouble signals shall be provided. The annunciator panel shall be automatically reset when the control panel is reset.

- F. A Keyed Switch shall be provided for remote reset of the system. The annunciation panel shall also be automatically reset when the control panel is reset.
- G. Provide a Floor Plan of the facility framed under acrylic and mounted adjacent to the fire alarm annunciator. The Floor Plan shall be to scale and shall have room numbers clearly displayed on all rooms corresponding to the annunciator for the purpose of easily identifying the fire zones.

2.08 REMOTE EQUIPMENT MONITORING AND CONTROL

- A. An Electronic Digital Multiplex Addressable Module shall be provided at each device or equipment indicated to be controlled by the multiplex system. Multiple addressable control ports shall be provided in each module quantity as required for each point controlled or monitored. The module shall communicate the monitor status control action and trouble condition of each device with a unique address code. The module shall communicate with and be supervised and monitored by the fire alarm control panel.
- B. Where Multiple Points are monitored or controlled, provide digital, multiplex, multi-points, monitor, control panel (MMCP). The panel cabinet shall be self-contained NEMA 1 construction and hinged locking door. Provide tamper switch detection zone on the cabinet door, provide 60-hour battery UPS backup and power supply, the same as required for the fire alarm control panel. Panel shall be expandable using plug-in circuit monitor/control printed circuit cards. Provide barriered numbered terminal strips.
- C. Each Control Point shall provide a supervised "dry" relay contact single pole double throw-maintained contact rated 10-amp, 227 volt, 60Hz AC.
- D. Each Monitor Point shall provide not less than one of the following supervised methods of monitoring a remote device or equipment action or status.
 - 1. Remote "dry" contact operation normal open, normally closed or momentary contact operation.

PART 3 - EXECUTION

3.01 IDENTIFICATION

- A. The Inside Cover of alarm initiating devices shall be marked with the zone initiating number corresponding to the zone number in the control panel. Marking shall be with a felt-tip pen.
- B. Each Fire Alarm Terminal Cabinet shall be painted red.
- C. Provide Nameplate: "Power to Main Fire Alarm Control Panel" screwed onto the branch circuit overcurrent device supplying power to the main fire alarm control panel.

3.02 WIRING

- A. Review the total system point-to-point wiring layout to assure that the correct number and type of wires and conduit sizes are installed.
- B. Final Connections, testing, adjusting and calibration shall be made under the direct supervision of a factory-trained Technician of the System Supplier.
- C. All Wiring shall be in red conduit.
- D. All Wiring in cabinets shall be neatly formed, laced and made up on bolt and nut terminal blocks. Tag all spare conductors. All conductors shall terminate on terminal strips with spade

lugs, of adequate size for all incoming and outgoing conductors. The strips shall be labeled as to their use and wiring diagram shall be placed on the cabinet door showing connections of all related equipment to these strips.

- E. Wiring Requirements for shielding certain conductors shall be as recommended by the Manufacturer. Provide all conduit, raceways and conductors per Manufacturers recommendations and include all material and labor costs in the Contract price.
- F. The Conductors used for digital, multiplex communication between the fire alarm control panel and external remote initiation devices, control points and annunciators, shall be twisted, shielded, multi-conductor cable, #16AWG copper minimum with a separate internal ground/drain conductor, UL listed for fire alarm system use. One spare pair of multiplex conductors shall be provided in all main and branch device/equipment connections for future system use. "Tees" and taps at any junction box location in the communication lines, shall be permitted by the system to additional devices without affecting proper system operation.
- G. Wire Size: Wire shall be sized to ensure installed circuit voltage drop does not exceed 10% to all devices.

3.03 OUTLET BOXES

Device Outlet Boxes shall be flush mounted unless indicated otherwise on the Drawings. Provide extension rings to finish flush with finish surface. Where the Drawings indicate surface mounted devices, outlet boxes shall be cast metal with threaded hubs. Where the conduit entrances are not exposed for surface mounted devices, provide flush outlet box behind the device box, and omit the conduit hubs on the device box. Size device boxes and outlet boxes per Manufacturer's recommendation and as required by Code for wire fills.

3.04 SPECIAL INSTALLATION REQUIREMENTS

- A. Air Duct Smoke Detectors shall be installed in the supply air ducts and return air ducts with an air flow of 2000 CFM or greater, coordinate with Mechanical Contractor. Sampling tube shall extend across entire duct width. Provide ¾-inch conduit with 2#12 to respective motor control device to automatically shut down the respective fan motor upon detection of smoke in the air duct. Installation shall be in compliance with CMC 606.8.
- B. Water Flow Switches shall be installed on each main fire sprinkler rise pipe, coordinate with the Fire Sprinkler Contractor.
- C. Tamper Switches shall be installed on each main fire sprinkler shut-off valve, coordinate with the Fire Sprinkler Contractor.
- D. Equipment shall be weatherproof gasketed where installed in locations exterior to the building, or where indicated on the Drawings. Weatherproof equipment shall be tamper resistant.
- E. Provide Clear Vandal Resistant Protective Cover for all audio-visual devices located in student restrooms and public hallways.
- F. Provide Wire Guard for ceiling mounted smoke and heat detectors located in student restrooms.
- G. Connect Fire Alarm Control Panel with security/intrusion control panel for monitoring by remote Monitoring Company.

- H. Connect Fire Alarm Control Panel with master clock system to turn off class passing schedule, with paging system to turn off system when fire alarm system in alarm condition.
- I. Conduit with fire alarm wiring shall be integral colored red conduit.
- J. Fire Alarm System shall be programmed per actual building and room designation. Submit printout for review.

3.05 TESTING

- A. The Entire Fire Alarm System shall be tested in the presence of the Local DSA Inspector and a Representative of the Manufacturer after the installation is complete.
 - 1. Individually activate each manual initiating station and verify correct alarm operation and control panel response.
 - 2. Individually test each automatic initiating device and verify correct alarm operation, control panel response and remote equipment operation.
 - 3. The communication loops and the notification alarm circuits shall be opened in at least two locations per building to check for the presence of correct supervisory circuitry.
- B. Test the Battery Back-Up System by disconnecting the incoming normal power and allowing this alarm system to operate 24 hours on battery power. Sound the alarm system for 5-minutes at the end of 24 hours on battery power.
- C. Perform all Electrical and Mechanical Tests required by the Equipment Manufacturer's certification form. Measure and adjust each automatic detection detector to the maximum stable sensitivity setting. Detector tests shall be performed with the detector at its operational location and under normal operational environmental conditions in the area. Bench settings are not acceptable. An operational check-out test and report shall be performed. Submit six copies of test report results. The tests and report shall include, but not be limited to:
 - 1. A complete list of equipment installed and wired.
 - 2. Indication that all equipment is properly installed and functions and conforms with these Specifications.
 - 3. Test of individual zones as applicable.
 - 4. Serial number locations by zone and model number for each installed detector.
 - 5. Voltage (sensitivity) settings for each ionization and photoelectric detector as measured in place with the HVAC system operating.
 - 6. Technician's name, certificate number and date.
 - 7. The completed manual and automatic monitoring and control system shall be tested to ensure that it is operating properly. This test will consist of exposing the installed units to a standard fire test.
 - 8. Acceptance of the system shall also require a demonstration of the stability of the system. This shall be adequately demonstrated if the system operates for a 90-day test period without any unwarranted alarms. Should an unwarranted alarm(s) occur, the Contractor shall readjust or replace the equipment and detector(s) and begin another 90-day test period. As required by the Architect, the Contractor shall recheck the detectors using the fire test after each readjustment or replacement of detectors. This

test shall not start until the District has obtained beneficial use of the building under tests.

- D. After the Testing has been completed to the satisfaction of CFC 907.9 – 907.9.4.1 the inspectors, provide the NFPA certificate of compliance to the District, the Local Fire Official, the Architect and DSA.
- E. Upon the receipt of Certificate of Compliance, the Installer/Supplier shall supply the District with a written operating, testing and maintenance instructions, Point-to-Point As-Built Drawings, and Equipment Specifications. Maintenance provisions, CFC 907.4.5.

3.06 INSTRUCTIONAL SESSIONS

Provide 2-hour instructional sessions conducted by a Factory-Authorized Technician at the job site after completion of all tests to instruct School District Personnel on the use of the system. The first session shall be videotaped and conducted prior to final acceptance of the Project. The second session shall be held within eleven months of final acceptance of the Project when requested by the District.

END OF SECTION 28 46 20

021821/212276

SECTION 31 10 00
SITE CLEARING

PART 1 - GENERAL

1.1 SUMMARY

- A. Contractor shall furnish all labor, materials, services, testing, transportation and equipment necessary for the completion of all site clearing work as required and as indicated on drawings and specified herein. Work materials and equipment not indicated or specified which is necessary for the complete and proper operation of the work of this Section in accordance with the true intent and meaning of the contract documents shall be provided and incorporated at no additional cost to the Owner.
- B. Removal of surface debris; removal of paving and curbs; removal of trees, shrubs, and other plant life; topsoil excavation; and repair of damaged vegetation and/or irrigation systems/system components.
- C. Removal of concrete and bituminous surfacing.

1.2 RELATED SECTIONS

- A. Section 01 71 23: Field Engineering.
- B. Section 01 57 23: Temporary Storm Water Pollution Control.

1.3 REFERENCE STANDARDS

- A. The work provided herein shall conform to and be in accordance with the Contract Plans, General Conditions/Specifications and Special Provisions, as well as the Standard Specifications for Public Works Construction ("GREENBOOK"), 2018 Edition, adopted by the Southern California Chapter, American Public Works Association; herein referred to as the "Standard Specifications".

1.4 REGULATORY REQUIREMENTS

- A. The Contractor shall obtain all necessary permits, licenses, or agreements required by any legally constituted agency, pay for all fees and give all necessary notices required for the construction of the work. The Owner shall reimburse the contractor for all necessary permits or inspection fees by any legally constituted agency.
- B. Perform all work of this Section in strict accordance with applicable Government Codes and Regulations especially meeting all safety standards and requirements of CAL/OSHA, County of

Los Angeles. Provide additional measures, added materials and devices as may be needed as directed by the Owner Representative at no added cost to the Owner.

- C. Comply strictly to Rule 1404, South Coast Air Quality Management District.
- D. Coordinate clearing Work with utility companies.

1.5 PROJECT CONDITIONS

- A. Traffic: Minimize interference with adjoining roads, streets, walks, and other adjacent occupied or used facilities during site-clearing operations.
 - 1. Do not close or obstruct streets, walks, or other adjacent occupied or used facilities without permission from Owner and authorities having jurisdiction.
 - 2. Provide alternate routes around closed or obstructed traffic ways if required by Owner or authorities having jurisdiction.
- B. Salvable Improvements: Carefully remove items indicated to be salvaged and store on Owner's premises where indicated.
- C. Do not commence site clearing operations until temporary erosion and sedimentation control measures are in place.
- D. Do not direct vehicle or equipment exhaust towards protection zones.
- E. Prohibit heat sources, flames, ignition sources, and smoking within or near protection zones.
- F. Soil Stripping, Handling, and Stockpiling: Perform only when the topsoil is dry or slightly moist.

PART 2 - PRODUCTS

- 2.1 Satisfactory Soil Materials: Excavated site soils, free of deleterious materials and rock particles larger than three (3) inches in the largest dimension, should be suitable for placement as compacted fill.

PART 3 - EXECUTION

3.1 PREPARATION

- A. Verify that existing plant life designated to remain is tagged or identified.
- B. Protect and maintain benchmarks and survey control points from disturbance during construction.

- C. Identify a waste area for placing removed materials.

3.2 TEMPORARY EROSION AND SEDIMENTATION CONTROL

- A. Provide temporary erosion and sedimentation control measures to prevent soil erosion and discharge of soil-bearing water runoff or airborne dust to adjacent properties and walkways, according to erosion- and sedimentation-control Drawings and requirements of authorities having jurisdiction.
- B. Retain first paragraph below if tree- or plant-protection zones are required.
- C. Verify that flows of water redirected from construction areas or generated by construction activity do not enter or cross protection zones.
- D. Inspect, maintain, and repair erosion- and sedimentation-control measures during construction until permanent vegetation has been established.
- E. Remove erosion and sedimentation controls and restore and stabilize areas disturbed during removal.

3.3 PROTECTION

- A. Protect existing structures and site improvements indicated to remain from damage by approved methods and/or as authorized by the Owner Representative. Removal of all protections shall be when work of this Section is completed or when so authorized by the Owner Representative.
- B. Protect Existing Utilities indicated or made known to remain traversing the job-site and serving existing adjacent facilities.
- C. Protect Existing Trees and Shrubs indicated to remain by providing temporary surrounding fencing so located a sufficient distance away so that trees and shrubs will not be damaged by site-clearing operations.
 - 1. Protection Barrier: A protection barrier shall be installed around the shrubs or trees to be preserved. The barrier shall be constructed of a durable fencing material, such as plastic construction fencing, snow fence, or chain link. The barrier shall be placed at or beyond the drip line. "Drip line" as referred to herein means a line which may be drawn on the ground around the tree directly under its outermost branch tips and which identifies that location where rainwater tends to drip from the tree. Placement of barrier to be approved by Owner Representative (Grounds Supervisor). If barrier is placed inside the drip line, then 3/4 inch plywood must be placed over the root zone up to the drip line. The fencing shall be maintained in good repair throughout the duration of the project, and shall not be removed, relocated, or encroached upon without permission of the Owner Representative (Grounds Supervisor).

2. Storage of Materials: There shall be NO storage of materials or supplies of any kind within the area of the protection barriers. Concrete, cement, asphalt materials, block, stone, sand and soil shall not be placed within the drip line of the tree(s).
3. Fuel Storage: Fuel storage shall NOT be permitted within 150 feet of any tree to be preserved. Refueling, servicing and maintenance of equipment and machinery shall NOT be permitted within 150 feet of protected trees.
4. Vehicles/equipment: NO parking or driving of vehicles or storage of equipment shall be permitted within the drip line of any tree to be preserved.
5. Debris and Waste Materials: Debris and waste from construction or other activities shall NOT be permitted within protected areas. Wash down of Concrete, cement or asphalt handling equipment, in particular shall NOT be permitted within 150 feet of protected areas.
6. Grade Changes: Grade changes can be particularly damaging to trees. Any grade changes should be approved by the Owner Representative (Grounds Supervisor) before construction begins and precautions taken to mitigate potential injuries.
7. Damages: Any damages or injuries to the preserved trees (including pruning or cutting of such trees not in conformity with the International Society of Arboricultural Pruning Guidelines and ANSI A300 Pruning Standards) shall be reported immediately to the Owner Representative (Grounds Supervisor). Severed roots shall be pruned cleanly to healthy tissue, using proper pruning tools. Broken branches/limbs shall be pruned according to International Society of Arboricultural Pruning Guidelines and ANSI A300 Pruning Standards. In the event that any damage, injury, improper pruning or cutting of a protected tree is deemed to be so substantial as to require its replacement (such determination to be made in the sole discretion of the Owner Representative), Contractor shall replace such tree with the same species and variety of tree, up to a box size of 48 inches, or if no such replacement is available, with a substitute species or variety as determined in the sole discretion of the Owner Representative. Any replacement tree shall be approved in advance by the Owner Representative. The value of the tree to be replaced shall be determined by a Certified Arborist selected by Contractor from the Owner's approved list of Registered Consulting Arborists. To the extent that the value of the replaced tree as determined by the Certified Arborist exceeds the cost of the replacement tree, Contractor shall be liable to Owner for such difference in value in addition to all costs associated with replacement of the damaged tree.
8. Removal of Existing Tree or Shrub: Prior to removing or cutting any trees designated for removal, the contractor shall coordinate with the Owner's Ground Supervisor. In the event that Contractor, a Subcontractor, Sub-Subcontractor, material supplier or anyone else performing the Work of the Contract willfully, negligently or mistakenly removes any tree or shrub not designated for removal, Contractor shall immediately report such removal to the Owner Representative (Grounds Supervisor). Contractor shall replace such tree with the same species and variety of tree, up to a box size of 48 inches, or if no

such replacement is available, with a substitute species or variety as determined in the sole discretion of the Owner Representative. Any replacement tree shall be approved in advance by the Owner Representative. The value of the tree to be replaced shall be determined by a Certified Arborist selected by Contractor from the Owner's approved list of Registered Consulting Arborists. To the extent that the value of the replaced tree as determined by the Certified Arborist exceeds the cost of the replacement tree, Contractor shall be liable to Owner for such difference in value in addition to all costs associated with replacement of the damaged tree.

9. Unauthorized Tree Removal or Injury: Criminal Penalties: Reference is made to California Penal Code §384a which provides that any person who willfully or negligently cuts, destroys, mutilates or removes any tree or shrub or portion thereof growing on public land without a written permit from the owner of said public land is guilty of a misdemeanor, subject to a fine of up to \$1,000, imprisonment in county jail for up to 6 months, or both. Contractor is advised that, in addition to all remedies provided herein and in the Contract Documents, the Owner shall cooperate with appropriate authorities in prosecuting and enforcing Penal Code §384a and other criminal sanctions as appropriate concerning trees and shrubs located on Owner property.
 10. Preventive Measures: Before construction begins fertilization of the affected areas to be applied at a rate to be determined by the Owner Representative (Grounds Supervisor).
- D. Protect bench marks, survey control points, and existing structures from damage or displacement.
 - E. Protection of Persons and Property (existing structures and site improvements):
 1. Provide barricades, warning signs at open depressions and holes on adjacent property and public accesses.
 2. Provide operating warning lights during hours from dusk to dawn each day or as otherwise required.
 3. Protect existing remaining structures, utilities, sidewalks, pavements other facilities from damage as caused by settlement, undermining, washout or other hazards created by site-clearing operations of this Section.
 - F. Use means necessary to prevent dust from becoming a nuisance to the public, to neighbors and to others performing work on or near the job-site.
 - G. Maintain access to the job-site at all times.

3.4 CLEARING AND GRUBBING

- A. Clear areas required for access to site and execution of Work.

- B. Remove all rubbish and debris existing and resulting from work operations of this Section as soon as possible, do not allow to pile up. Do not burn rubbish and debris on the job-site.
- C. Where active utility lines need to be capped or plugged, perform such work in accordance with requirements of the Utility Company.

3.5 REMOVAL

- A. Remove debris, rock, and extracted plant life from site.
- B. Excavate and remove associated plumbing piping.
- C. Prior to demolition work, the Contractor shall notify the Owner Representative to identify the existing items for salvage purposes. The materials identified for salvage shall be returned to the Owner in a timely manner agreed upon by the Owner Representative.

3.6 CONCRETE AND BITUMINOUS SURFACE REMOVAL

- A. Where noted on the construction drawings, break up and completely remove all existing concrete surfacing, curbs, gutters, walks and bituminous surfacing to limits indicated to be removed. All cutting shall be done to a neat and even line with proper tools or a concrete cutting saw. Minimum depth of cut shall be 1-1/2", unless otherwise specified. Remove any concrete broken beyond the indicated limits to the nearest joint or score line and replace with new concrete to match the existing.
- B. Removed concrete and bituminous materials shall be disposed of off-site unless otherwise noted on the construction drawings. All such items to be removed shall be disposed of off the property in a legal manner.
- C. Bituminous pavement saw cutting shall conform to the provisions of Section 300-1.3.2 (a) of the Standard Specifications. The residue resulting from the saw cutting operations shall not be permitted to flow beyond the specific work location and shall be removed the same day.
- D. Removal of concrete curb / curb & gutter covered by this section shall include saw-cutting and removal of a twelve (12") inch wide section of the adjacent bituminous pavement.
- E. When saw cutting concrete curb / curb & gutter, the cuttings shall be continuously wet vacuumed to prevent the materials from entering catch basins, storm water conveyances, or waters of the State. Vacuumed cuttings shall be disposed of according to applicable regulations.
- F. Concrete curb and concrete curb and gutter shall be removed to the lines, grades and locations shown on the plans in accordance with Section 300-1.3.2 of the Standard Specifications.

- G. Concrete removal in sidewalk and driveway areas shall extend to existing score lines unless specifically indicated otherwise on the Plans or in the Project Special Provisions, or unless otherwise approved by the Engineer.
- H. Reinforcing or other steel may be encountered in portions of concrete to be removed. No additional compensation will be allowed for the removal of concrete containing reinforcing or other steel.
- I. In those areas where existing bituminous surfacing is removed to make way for new planting or lawn areas, remove soil 6" below existing exposed soil surface. Removed soil may be used only as fill under buildings or other areas to be paved, only if approved by the Owner Inspector. Legally dispose of off site, if material is not approved as fill material.

3.7 REPAIRS

- A. During demolition and construction, ensure that trees, shrubs and other plant material and vegetation are protected inside and outside of the work zone and that the vegetation is being watered, maintaining the proper moisture content according to the season. Failed vegetation, including sod, due to lack of water, and/or plant material destroyed during construction period are to be replaced to equal or better size and condition at no additional cost to the Owner.
- B. If the irrigation system is damaged or modified during construction, it shall be repaired to the Owners standards, and shall be in equal or better condition than prior to damage or modification. All repairs shall be, inspected and approved by the Owner Representative (Grounds Supervisor) prior to backfilling or covering of said repairs. The Owner representative requires forty-eight hours prior notice, when contractor requests inspection of completed repairs. All repairs shall be made so as to ensure proper operation prior to the close of the contract at no additional cost to the Owner.
- C. Controller Wires: If damaged, cut or removed, repair by splicing, soldering and silicone sealing. To ensure proper operation, reconnect the wires to the valve to correspond with the map on the controller to the correct station.
- D. Hydraulic Tubes: If damaged/cut or removed, repair by replacing the tubing using equal or better material.
- E. Valves: If damaged, repair/replace with equal or better material. All valves are to be flushed/cleaned thoroughly.
- F. Mainlines: If damaged, repair/replace with equal or better material. All lines are to be flushed/cleaned thoroughly.
- G. Lateral Lines: If damaged, repair/replace with equal or better material. All lines are to be flushed/cleaned thoroughly.
- H. Irrigation Heads: If damaged, repair/replace with equal or better material. All heads are to be flushed and filters cleaned thoroughly.

- I. Controllers: If damaged repair/replace with equal or better material.
- J. Backflow Prevention Devices: If damaged, repair/replace with equal or better material.
- K. Gate/Ball/Quick Coupler Valves: If damaged repair/replace with equal or better material.
- L. Valve Boxes: If damaged, repair/replace with equal or better material. Concrete boxes and concrete lids with the appropriate markings for identification shall be used. The top of the box shall be buried below finish grade, equal to existing depth or deeper. The top of the valve stems shall be 6" below the underside of the top of the box.
- M. Construction in grass areas: Sod shall be removed by sod cutting at a soil depth of 2", stored on site, and watered on a daily basis. Upon completion of work, stored sod shall be reinstalled over the areas disrupted due to construction. An option may be to bypass cutting the sod, however at the completion of the project, finish grading and installation of new Hybrid Bermuda GN -1 sod over the areas disrupted by construction shall be required.

3.8 EXCESS MATERIALS DISPOSAL

- A. Remove surplus soil material, unsuitable topsoil, obstructions, demolished materials, and waste materials, including trash and debris, and legally dispose of them off Owner's property.
- B. Separate recyclable materials produced during site clearing from other non-recyclable materials. Store or stockpile without intermixing with other materials and transport them to recycling facilities. Do not interfere with other Project work.

3.9 SITE CLEANUP

- A. Cleanup of branches, limbs, logs, or any other debris resulting from any operations shall be promptly and properly accomplished. The work area shall be kept safe at all times until all operations are completed. Under no circumstances shall the accumulation of brush, limbs, logs, or other debris be allowed in such a manner as to result in a hazard to the public. All debris shall be cleaned up each day before the work crew leaves the site, unless permission is given by the Owner to do otherwise. All lawn areas shall be raked, all streets and sidewalks shall be swept, and all brush, branches, rocks or other debris shall be removed from the site. Areas are to be left in a condition equal to or better than that which existed prior to the commencement of operations.

END OF SECTION

SECTION 31 22 00

GRADING

PART 1 - GENERAL

1.01 SUMMARY

- A. The work of this section shall include excavation, unclassified cut, unclassified fill, removing existing unsatisfactory material, preparing areas to be filled, spreading and compacting of fill in the areas to be filled, and all other work necessary to complete the grading of the site. It shall be the Contractor's responsibility to place, spread, moisten or dry, and compact the fill in strict accordance with these specifications to the lines and grades indicated on project plans or as directed in writing by the Geotechnical Engineer. Included with this Work are the following:
1. General exterior grading, cutting and filling, including grading for building area, paving, planting areas, banks and hillsides.
 2. Excavating, filling, backfilling, and compacting for Project site pavement, planting areas, buildings, and other structures.
 3. Base course for walks and pavements.
 4. Subsurface drainage backfill for walls and trenches.
 5. Excavating and backfilling trenches within buildings lines.
 6. Excavating and backfilling for underground mechanical and electrical utilities and appurtenances.
 7. Shoring plan guidelines.
- B. Related Sections: The following Sections contain requirements that relate to this Section.
1. Section 01 71 23 - Field Engineering.
 2. Section 32 12 16 - Asphalt Paving.
 3. Section 32 13 13 - Cement Paving.

1.02 DEFINITIONS

- A. Excavation consists of the removal of material encountered to subgrade elevations and the reuse or disposal of materials removed.
- B. Subgrade: The uppermost surface of an excavation or the top surface of a fill or backfill immediately below subbase, drainage fill, or topsoil materials.
- C. Borrow: Soil material obtained off site when sufficient approved soil material is not available from excavations.

- D. Base Course: The layer placed between the subgrade and surface pavement in a paving system.
- E. Drainage Fill: Course of washed granular material supporting slab on grade placed to cut off upward capillary flow of pore water.
- F. Permeable Backfill: Provide permeable backfill material behind retaining structures consisting of gravel, crushed gravel, crushed rock, natural sands, manufactured sand, or combinations.
- G. Unauthorized excavation consists of removing materials beyond indicated subgrade elevations or dimensions without direction by the Architect. Unauthorized excavation, as well as remedial work directed by the Architect, shall be at the Contractor's expense.
- H. Structures: Buildings, footings, foundations, retaining walls, slabs, tanks, curbs, mechanical and electrical appurtenances, or other man made stationary features constructed above or below ground surface.
- I. Utilities include underground pipes, conduits, ducts, and cables, as well as underground services within building lines.

1.03 SUBMITTALS TO CONSTRUCTION MANAGER

- A. General: Submit the following according to the Conditions of the Contract and Division 1 Specification Sections.
- B. Product data for the following:
 - 1. Each type of plastic warning tape.
 - 2. Filter fabric.
- C. Samples of the following:
 - 1. 12 by 12 inch sample of filter fabric.
- D. Test Reports: In addition to test reports required under field quality control, submit the following:
 - 1. One optimum moisture-maximum density curve for each soil sample.
 - 2. Laboratory analysis of each soil material proposed for fill or backfill from borrow sources.
- E. Excavation support & protection (shoring) shop drawings for informational purposes: Prepared by or under the supervision of a qualified professional engineer for excavation support and protection systems.

1.04 QUALITY ASSURANCE

- A. Codes and Standards:
 - 1. 2019 California Building Code, Title 24, Part 2, Volume 2 of 2, Appendix J, Grading.

2. ASTM D422 - Method for Particle Size Analysis of Soils
 3. ASTM D1556 - Test Method for Density of Soil in Place by the Sand-Cone Method.
 4. ASTM D1557 - Test Methods for Moisture-Density Relations of Soils and Soil-Aggregate Mixtures Using 10-lb (4.54 kg) and 18-inch (457-mm) Drop.
 5. ASTM D2216 - Method for Laboratory Determination of Water (Moisture) Content of Soil, Rock, and Soil Aggregate Mixtures.
 6. ASTM D2922 - Test Method for Density of Soil and Soil-Aggregate in Place by Nuclear Methods (Shallow Depths).
 7. ASTM D3017 - Test Method for Moisture Content of Soil and Soil-Aggregate in Place by Nuclear Methods (Shallow Depths).
 8. ASTM D4318 - Test Method for Liquid Limit, Plastic Limit and Plasticity Index of Soils.
 9. AASHTO T217 - Determination of Moisture in Soils by Means of a Calcium Carbide Gas Pressure Meter.
 10. ASTM D4829 - Expansion Index Test.
- B. The work provided herein shall conform to and be in accordance with the Contract Plans, General Conditions/Specifications and Special Provisions, as well as the Standard Specifications for Public Works Construction ("GREENBOOK"), 2018 Edition, adopted by the Southern California Chapter, American Public Works Association; herein referred to as the "Standard Specifications".
- C. Comply with all requirements of permit for export of soil from site. Permit is to be obtained and paid for by Contractor. Furnish copies of all permits and licenses required by the local jurisdiction to Owner's representative.
- D. Professional Observation: A soils engineer will be retained by the Owner for purposes of inspection, testing and approval of all work under this section. Perform work of this Section under inspection and approval of the soils engineer. Give soils engineer not less than 48 hours advance notice of readiness for inspection.
- E. The soils engineer will have the authority over all filling, grading, and compaction operations, including interruption of work if deemed necessary due to improper work
- F. Pre-Grading Conference: Conduct conference at Project site to comply with requirements of Division 1 Section "Project Meetings."
1. Before commencing earthwork operations, meet with representatives of the governing authorities, Owner, Architect, consultants, Geotechnical Engineer, independent testing agency, and other concerned entities. Review earthwork procedures and responsibilities including testing and inspection procedures and requirements. Notify participants at least 3 working days prior to convening conference. Record discussions and agreements and furnish a copy to each participant.

1.05 CONSTRUCTION MONITORING

- A. All earthwork and foundation construction should be monitored by a qualified engineer/technician under the supervision of a Geotechnical Engineer, including;
 - 1. Observation of all site preparations;
 - 2. Observation of shoring installation, if needed;
 - 3. Observation of all site excavations;
 - 4. Test and approval of all import soil;
 - 5. Observation of placement of all compacted fills and backfills;
 - 6. Observation of all surface and subsurface drainage systems;
 - 7. Observation of all foundation and pile excavations;
 - 8. Observation of subgrade preparation for paved and building areas.

- B. The Geotechnical Engineer of Record should be notified at least three (3) days in advance of the start of construction. A joint meeting between the Contractor and Geotechnical Engineer is recommended prior to the start of construction to discuss specific procedures and scheduling. The Geotechnical Engineer should be present to observe the soil conditions encountered during construction, to evaluate the applicability of the recommendations presented in the Soils Report to the soil conditions encountered, and to recommend appropriate changes in design or construction if conditions differ from those described herein. The Geotechnical Engineer of Record should inspect and approval all imported backfill material prior to its placement as backfill, approve the subgrade beneath all fills, fill placement and bottom of all foundation excavations before concrete or steel is placed.

- C. The Geotechnical Engineer shall submit compaction reports to the Construction Manager and the Civil Engineer at the completion of the work, including test results and plot plans indicating the locations from which the tested samples of fill were taken. The Geotechnical Engineer shall keep the Construction Manager informed on the progress of the grading work.

1.06 IMPORT AND EXPORT OF EARTH MATERIALS

- A. Fees: Pay as required by government authority having jurisdiction over the area.
- B. Bonds: Post as required by government authority having jurisdiction over the area.
- C. Hauling Routes and Restrictions: Comply with requirements of authorities having jurisdiction over the area.

1.07 TRUCK HAUL ROUTE

- A. A proposed truck haul route is to be submitted to the local City jurisdiction for review and approval. Upon approval, an approved copy shall be returned to the Contractor.

The Contractor shall post an approved copy on the job site. All trucks working that project shall also carry a copy. If a truck(s) is found not to be carrying an approved copy, the Contractor shall be subject to a Notice of Noncompliance (stop work order)

- B. All trucks must cover their dirt with an acceptable tarp during transport for dust containment. Provisions for street sweeping and watering will also be required unless an active wheel washing facility proves that they are un-necessary to the satisfaction of the Engineer.
- C. All truck haul routes, as approved, are good only for the project time period, and trucks shall have to comply with the approved route only. If during the progress of the project an alternate route is needed, the Contractor shall submit a new plan. The haul route application shall contain the following information:
 - 1. Map showing the proposed route
 - 2. Project name
 - 3. Grading Contractor's name, address and phone number
 - 4. Type of material being hauled
 - 5. Encroachment or construction permit number

1.08 DIG ALERT NOTIFICATION

- A. Before any excavation in or near the public right-of-way, the Contractor must contact the Underground Service Alert of Southern California (Dig Alert) at **811** for information on buried utilities and pipelines.
- B. Delineation of the proposed excavation site is mandatory. Mark the area to be excavated with water soluble or chalk based white paint on paved surfaces or with other suitable markings such as flags or stakes on unpaved areas.
- C. Call at least Two (2) full working days prior to digging.
- D. If the members (utility companies) have facilities within the work area, they will mark them prior to the start of your excavation and if not, they will let you know there is no conflict. A different color is used for each utility type (electricity is marked in red, gas in yellow, water in blue, sewer in green, telephone and cable TV in orange).
- E. The Law requires you to hand expose to the point of no conflict 24" (inches) on either side of the underground facility, so you know its exact location before using power equipment.
- F. If caught digging without a Dig Alert ticket you can be fined as much as \$50,000 per California government code 4216.

1.09 SUBSURFACE CONDITIONS

- A. Where investigations of subsurface conditions have been made by the Owner with respect to subsurface conditions, utilities, foundation, or other structural designs, and

that information is shown in the Plans, it represents only a statement by the Owner as to the character of materials which have actually been encountered by the Owner's investigation. This information is only included for the convenience of Bidders.

- B. Investigations of subsurface conditions are made for the purpose of design only. The Owner assumes no responsibility with respect to the sufficiency or accuracy of borings or of the log of test borings or other preliminary investigations or of the interpretation thereof. There is no guaranty, either expressed or implied, that the conditions indicated are representative of those existing throughout the Work, or any part of it, or that unanticipated conditions may not occur. When a log of test borings is included in the Plans, it is expressly understood and agreed that said log of test borings does not constitute a part of the Contract. The log of test borings represents only an opinion of the Owner as to the character of the materials to be encountered, and is included in the Plans only for the convenience of the Bidders. Making information available to Bidders is not to be construed in any way as a waiver of the provisions of the first paragraph of this Section, and Bidders must satisfy themselves through their own investigations as to conditions to be encountered.

1.10 GRADING

- A. If the Contractor encounters any suspected cultural resource, or unique archaeological or paleontological resource, during the course of construction, the Contractor shall halt or divert work and notify the District Representative immediately. The District will evaluate the situation and if warranted, will consult with a qualified archeologist or paleontologist to determine further actions.
- B. If human remains are encountered unexpectedly during construction excavation and grading activities, the State Health and Safety Code Section 7050.5 requires that no further disturbance shall occur until the County Coroner has made the necessary findings as to origin and disposition pursuant to PRC Section 5097.98, and the Contractor will notify the District Representative immediately. If the remains are determined to be of Native American descent, the coroner has 24 hours to notify the Native American Heritage Commission.

1.11 PROJECT CONDITIONS

- A. Data: Maps, boring logs, geotechnical and foundation investigation reports, and like reference data, not included in Contract Documents but made available to Contractor by Architect or Owner are for information only, and the Architect and Owner assume no responsibility for any conclusions Contractor may draw from such information. Should questions or issues arise, contact Architect or Owner for clarification.
- B. Contractor shall determine existing conditions under which the Contractor will operate in performing the Work.
- C. Information on Drawings does not constitute a guarantee of accuracy or uniformity of soil conditions over the Project site.

- D. Existing utilities: Locate existing underground utilities in all areas of work prior to excavation or commencement of work. If utilities are to remain in place provide adequate means of protection during earthwork operations.
 - 1. Should uncharted, or incorrectly charted piping or other utilities be encountered during excavation, consult Utility Owner immediately for direction. Cooperate with Owner and Utility companies in keeping respective services and facilities in operation. Repair damaged utilities to the satisfaction of Utility Company.
 - 2. Do not interrupt existing utilities serving facilities occupied or used by Owner, or others, except when permitted in writing by Owner's Representative, and then only after acceptable temporary services have been provided.
 - 3. Demolish and completely remove from site existing underground utilities indicated to be removed. Coordinate with utility companies for shut off of services if lines are active.
- E. Noise and Dust Abatement: Exercise all reasonable and necessary means to abate dust, dirt rising and undue noise. Perform necessary sprinkling and wetting of construction site to allay dust as required by applicable codes and ordinances.
- F. Water for Grading: Contractor shall obtain and pay for all water required for his grading operation. This may include, but is not limited to, payment of deposits to utility for construction meter, and payment of all monthly service and water charges. Construction meter shall be in place throughout construction period unless alternative arrangements are made with the Water Department to provide construction water for all purposes. Contractor shall be aware of water moratoriums and restrictions, and shall immediately advise Owner of effects on construction schedules.
- G. Existing Conditions: Prior to commencing work at site, verify agreement of existing conditions with indicated conditions. Notify Owner's Representative in writing of discrepancies found. Start of work without notification constitutes acceptance of conditions, without cause for extra compensation.
- H. Field obstructions, grade differences or differences in dimensions may exist that might not have been considered or observed during design of this project. Contractor shall promptly notify the Engineer and the Agency having jurisdiction by telephone and in writing upon discovery of and before disturbing, any physical conditions differing from those represented by approved plans and specifications. In the event this notification is not performed, the Contractor shall assume full responsibility for necessary revisions.

PART 2 - PRODUCTS

2.01 SOIL MATERIALS

- A. General: All soils materials to be used throughout the site shall be approved for use by the Geotechnical testing engineer. Provide approved borrow soil materials from off site when sufficient approved soil materials are not available from excavations.
- B. No earthwork analysis has been completed with respect to the volumes of soils to be excavated, placed, or imported in order to provide the finished grades shown on the

plans. The Contractor is solely responsible for verifying the earthwork quantities necessary to complete the project.

- C. The change in volume of excavated and recompacted soil varies according to soil type and location. This volume change is represented as a percentage increase (bulking) or decrease (shrinkage) in volume of fill after removal and recompaction. Field and laboratory data used in our calculations included laboratory-measured maximum dry density for the general soil type encountered at the subject site, the measured in-place densities of near surface soils encountered and our experience. We preliminarily estimate the onsite undocumented fill and alluvial materials requiring removal and recompaction will have a shrinkage factor of approximately 10 percent during grading. The level of fill compaction, variations in the dry density of the existing soils and other factors influence the amount of volume change. Some adjustments to earthwork volume should be anticipated during grading of the site.
- D. Satisfactory Soil Materials: On-site subgrade soils at their present state exhibit satisfactory expansion indexes and are therefore deemed suitable for re-use as compacted fill. Soil shall be free of debris, particles greater than 4-inches, organic matter or other deleterious materials.
- E. Borrow / Imported Fill Material: Soil excavated from site or imported conforming to requirements for fill material.
 - 1. Any imported fill material should consist of granular soil having a “very low” expansion potential (that is, expansion index of 20 or less). Import material should also have low corrosion potential (that is, chloride content less than 500 parts per million [ppm], soluble sulfate content of less than 0.1 percent, and pH of 5.5 or higher). Materials to be used as fill should be evaluated by the Geotechnical representative prior to importing or filling.
- F. Base Course Material For Use Under Asphalt Pavement: Crushed aggregate base material shall consist of materials that meet the provisions listed below.
 - 1. Crushed Aggregate Base (CAB) per Section 200-2.2, 3/4” maximum of the Standard Specifications for Public Works Construction (Green Book).
 - 2. Crushed miscellaneous base (CMB) is not acceptable.
- G. Bedding Material for Trenches:
 - 1. Bedding sand shall be as defined by Standard Specifications, Section 200-1.5, and shall be free of expansive material and organic matter. Bedding material for utility lines outside the property lines shall be as required by the agency having jurisdiction. On-site soils are not considered suitable for bedding or shading of utilities.
 - 2. Sand providing a sand equivalent of at least 30. Flooding and jetting shall not be permitted without prior written approval from the Geotechnical Engineer. Where sheeting or shoring is used densification of the bedding shall be accomplished after the sheeting or shoring has been removed from the bedding zone, unless the sheeting or shoring is to be cut off or left in place. Pipe bedding material shall be placed in horizontal layers not exceeding (8) eight inches.

- H. Backfill Material for Trenches:
1. The on-site soils have been determined to be suitable for being used for backfilling purposes in trenches. Utility trenches should be backfilled with granular materials and mechanically compacted to at least 90% of the maximum dry density of the soils.
- I. Gravel Fill Material: Shall be from an approved source, having the following gradation: 90-100% passing a 3/4" sieve, 0% to 10% passing a No. 4 sieve, and 0% to 3% passing a No. 100 sieve.
- J. Filter Fabric: Manufacturer's standard nonwoven geotextile fabric of polypropylene geotextiles, "Mirafi 140N" or approved equal
1. Provide filter fabrics that meet or exceed the listed minimum physical properties determined according to ASTM D 4759 and the referenced standard test method in parentheses:
 - a. Grab Tensile Strength (ASTM D 4632): 100 lb.
 - b. Apparent Opening Size (ASTM D 4751): #70 U.S. Standard sieve.
 - c. Permeability (ASTM D 4491): 135 gallons per minute per sq. ft.

2.02 ACCESSORIES

- A. Detectable Warning Tape: Acid and alkali-resistant polyethylene film metallic warning tape manufactured for marking and identifying underground utilities, 6 inches wide and 4 mils thick minimum, continuously inscribed with a description of the utility, with metallic core encased in a protective jacket for corrosion protection, detectable by metal detector when tape is buried up to 30 inches deep.
1. Tape Colors: Provide tape colors to utilities as follows:
 - a. Red: Electric.
 - b. Yellow: Gas, oil, steam, and dangerous materials.
 - c. Orange: Telephone and other communications.
 - d. Blue: Water systems, with "Caution: Water Line Below."
 - e. Green: Sewer systems, with "Caution: Sewer Line Below."
 - f. Green: Storm systems, with "Caution; Storm Drain Line Below."

2.03 EXCAVATION SUPPORT & PROTECTION – SHORING PLAN

- A. The CONTRACTOR shall have at the Worksite, copies or suitable extracts of: Construction Safety Orders, Tunnel Safety Orders and General Industry Safety Orders issued by the State Division of Industrial Safety. The CONTRACTOR shall comply with provisions of these and all other applicable laws, ordinances, and regulations.

- B. Before excavating any trench 5 feet or more in depth, the CONTRACTOR shall submit a detailed plan to the Owner showing the design of shoring, bracing, sloping, or other revisions to be made for the Workers' protection from the hazard of caving ground during the excavation of such trench. If the plan varies from the shoring system standards, the plan shall be prepared by a registered Civil Engineer. No excavation shall start until the DISTRICT has accepted the plan and the CONTRACTOR has obtained a permit from the State Division of Industrial Safety. A copy of the permit shall be submitted to the DISTRICT.
- C. The INSPECTOR will provide a competent person trench/excavation certification form to the CONTRACTOR. It shall be completely filled out before any worker has access to trench or excavation and returned to the INSPECTOR before the end of the first working day. The CONTRACTOR shall certify by this form the name of the competent person administering the Work, the soil classification, and the type of excavation protective system provided and/or installed.
- D. The CONTRACTOR shall completely fence all excavations to provided protection against anyone falling into the excavation and to the satisfaction of the INSPECTOR. The fencing shall be in place at all times except when workers are present and actual construction operations are in progress.
- E. The fencing material shall be chain link fabric or welded wire fabric (6x6-W9xW9 minimum) and 6 feet high, constructed according to one of the following:
 - 1. Tensioned fencing material and have top and bottom tension wires securely fastened to driven steel posts or other equally rigid elements at a maximum spacing of 12 feet; or
 - 2. Untensioned fencing materials securely fastened to extended trench shoring elements at a maximum spacing of 8 feet and fastened to continuous top and bottom rails constructed of nominal 2 in x 4 in lumber or equally rigid material. Framed panels with suitable supporting elements fastened together to form a continuous fence may also be used.
- F. Payment for performing all work necessary to provide safety measures shall be included in the prices bid for other items of work except where separate bid items for excavation safety are provided, or required by law.

PART 3 - EXECUTION

3.01 PREPARATION

- A. Protect adjacent property and existing improvements and structures as necessary to prevent undermining, caving of cuts, and miscellaneous damage.
- B. Provide cribbing, sheeting, and shoring necessary to safely retain the earth banks and protect excavations and adjoining grades from caving and other damage resulting from excavating together with suitable forms of protection against bodily injury to personnel employed on the work and the general public. Be responsible for the design, installation, and maintenance of required cribbing and shoring and shall meet the

approval of the State Division of Industrial Safety and local governing agencies requirements.

- C. Utility lines and structures shown shall be protected and treated as indicated. Where work not shown is encountered, report it to the Architect before proceeding with excavation. Encase active lines in sleeves where they pass through concrete; remove inactive lines as directed, and plug the remaining ends. Bear the costs for repairs to damaged or broken utilities and any damages related thereto.
- D. Protect existing improvements and adjacent properties from storm damage and flood hazard originating on this project until final acceptance by the Owner. Prevent silt runoff from the limits of work in accordance with governmental requirements.
- E. An 8 foot high, temporary chain link fence with visual screen and gates, (pair 26' wide, minimum) shall be erected prior to any grading operations at the construction limits perimeter. Coordinate the exact location with Architect and District.

3.02 DEWATERING

- A. Prevent surface water and subsurface or ground water from entering excavations, from ponding on prepared subgrades, and from flooding Project site and surrounding area. Any water entering an excavation shall be immediately pumped out and the exposed excavation allowed to dry.
- B. Protect subgrades and foundation soils from softening and damage by rain or water accumulation.

3.03 GRADE STAKES

- A. The Contractor's Surveyor will set grade stakes. The Surveyor shall be a California registered land surveyor or licensed Civil Engineer. The Surveyor shall be hired and paid by the Contractor, and shall be subject to the approval of the District. Contractor shall notify the District at least 48 hours before staking is to be started. The District will determine if work is ready for staking.
- B. All work shall conform to the lines, elevations, and grades shown on the Construction Plans. Three consecutive points set on the same slope shall be used together so that any variation from a straight grade can be detected. Any such variation shall be reported to the Engineer. In the absence of such report, the Contractor shall be responsible for any error in the grade of the finished work.
- C. Protect and maintain stakes in place until their removal is approved by the District. Grade or location stakes lost or disturbed by Contractor, shall be reset by the Surveyor at the expense of Contractor.
- D. Grades for underground conduits will be set at the surface of the ground. The Contractor shall transfer them to the bottom of the trench.

3.04 TEMPORARY EXCAVATION

- A. Temporary excavations for the demolishing, earthwork, footing and utility trench construction are expected. We anticipate that unsurcharged excavations with vertical side slopes less than 4 feet high will generally be stable; however, some sloughing of cohesionless sandy materials encountered at the site should be expected.
- B. Where the space is available, temporary, unsurcharged excavation sides over 4 feet in height should be sloped no steeper than an inclination of 1H:1V (horizontal:vertical). Where sloped excavations are created, the tops of the slopes should be barricaded so that vehicles and storage loads do not encroach within 10 feet of the top of the excavated slopes. A greater setback may be necessary when considering heavy vehicles, such as concrete trucks and cranes. The geotechnical representative should be advised of such heavy vehicle loadings so that specific setback requirements can be established. If the temporary construction slopes are to be maintained during the rainy season, berms are recommended to be graded along the tops of the slopes in order to prevent runoff water from entering the excavation and eroding the slope faces.
- C. Excavations should not undermine any existing adjacent building footings. Where space for sloped excavations is not available, slot cuts or temporary shoring (for example, a trench box) may be utilized. For temporary excavations that are less than 6 feet in height adjacent to existing buildings where the excavation extends deeper than the bottom of the existing footing, slot cuts may be utilized. The slots should be no wider than 8 feet and should be excavated in an A-B-C sequence such that there is at least 16 feet spacing between any two excavated slots. The excavated slots should not be left open overnight and should be backfilled on the same day they were excavated before prior to excavation of the next set of slots.

3.05 HAZARDOUS MATERIALS

- A. All import fill material shall be characterized, handled, and documented in accordance with applicable US EPA and State of California hazardous waste and hazardous materials regulations.
- B. "Contaminated" shall mean any soil or geotechnical material at a concentration, which would require disposal at a regulated facility (i.e., California hazardous or RCRA hazardous).
- C. Owner's Authorized Representative (OAR) must be notified at least 72 hours prior to the disposal of any hazardous waste or hazardous material. No material disposal or reuse can take place without prior written approval of the OAR.

3.06 TRENCH EXCAVATION, BACKFILL & COMPACTION FOR UTILITIES

- A. Field conditions may require deviations from information indicated on Drawings. Such changes in work shall be covered by a Change Order, indicating an increase or decrease in the Contract sum.
- B. Before excavation, Contractor shall contact the "Underground Service Alert of Southern California" (USASC) for information on buried utilities and pipelines.

- C. When connections are to be made to any existing pipe, conduit, or other appurtenances, the actual elevation or position of which cannot be determined without excavation, the Contractor shall excavate for, and expose, the existing improvement before laying any pipe or conduit. The Engineer shall be given the opportunity to inspect the existing pipe or conduit before connection is made. Any adjustments in line or grade which may be necessary to accomplish the intent of the plans will be made, and the Contractor will be paid for any additional work resulting from such change in line or grade.
- D. Trenches, ditches, pits, sumps, and similar items which are outside the barricaded working area shall be barricaded to conform to Cal OSHA standards.
- E. Trenches over 5'-0" in depth shall conform to the Construction Safety Orders of the California Division of Industrial Safety, see Section 2.3 EXCAVATION SUPPORT & PROTECTION – SHORING PLAN.
- F. Safe and suitable ladders which project 2 feet above the top of the trench shall be provided for all trenches over 4 feet in depth. One ladder shall be provided for each 50 feet of open trench, or fraction thereof, and be so located that workers in the trench need not move more than 25 feet to a ladder.
- G. Where indicated and/or required to excavate in lawn areas, protect adjoining lawn areas outside of the Work area. Replace or install removed sod upon completion of backfill by installing sod level with adjacent lawns. If installation of removed sod fails, furnish sod and install to match existing lawns.
- H. All trenches should be backfilled with approved fill material compacted to relative compaction of not less than 90 percent of maximum density determined in accordance with ASTM D 1557. Backfill shall be placed in layers not exceeding 8" (inches) in thickness.
- I. Backfill over excavations to the required elevations with earth, gravel, sand, or concrete and compact as required. Provide excavations free from standing water by pumping, draining, or providing protection against water intrusion. Slope adjacent grades away from excavations to minimize entry of water.
- J. Do not excavate trenches parallel to footings closer than 18" from the face of the footing or below a plane having a downward slope of 2 horizontal to one vertical, from a line 9" above bottom of footings.
- K. If soft, spongy, unstable, or other unsuitable material is encountered upon which the bedding material or pipe is to be placed, this material shall be removed to a depth ordered by the Engineer and replaced with bedding material suitably densified. Additional bedding so ordered, over the amount required by the Plans or Specifications, will be paid for as provided in the Bid. If the necessity for such additional bedding material has been caused by an act of failure on the part of the Contractor or is required for control of groundwater, the Contractor shall bear the expense of the additional excavation and bedding.

- L. Unless indicated otherwise on the plans are within this specification, excavate trenches to the required depths for utilities, such as pipes, conduit and tanks, with minimum allowances of 6 inches at the bottom and 6 inches at the sides for bedding of unprotected piping or as required for concrete encasement of conduits as indicated on Drawings. Maximum allowances at the sides for trenching shall be 12 inches. Grade bottom of trenches to a uniform smooth surface. Remove loose soil from the excavation before installing sand bedding or concrete encasement.
- M. Where portions of existing structures, walks, paving, etc. must be removed or cut for pipe or conduit installation, replace the material with equal quality, finished to match adjacent work.
- N. Provide a minimum clear dimension of 6 inches from sides of wall excavation to outer surfaces of buried pipes or conduits installed in the same trench or outside surfaces of containers and/or tanks.
- O. **DO NOT** place backfill until the bedding and pipe work installed has been inspected, tested and approved by the Inspector. Remove excavated rocky material unsuitable for backfill from the site prior to final backfilling.
- P. Bedding material immediately around a utility line and to a point 12 inches above the top of pipe should consist of sand to support the line and protect it.
- Q. Bedding zone shall be defined as the area containing the material specified that is supporting, surrounding, and extending to 12" (inches) above the top of pipe. Compaction requirements in this area must meet 90%.
- R. Bedding material shall first be placed on a firm and unyielding subgrade so that the pipe is supported for the full length of the barrel. There shall be 6" (inch) minimum of bedding below the pipe barrel and 1" (inch) clearance below a projecting bell for sewer, storm drain and water pipe. The material in the bedding zone shall be placed and densified by mechanical compaction only.
- S. Mechanically compacted backfill shall comply with section 306-1.3.2 of the Standard Specifications for Public Works Construction.
- T. Concrete backfill trenches that carry below or pass under footings and that are excavated within 18 inches of footings. Place concrete to level of bottom of footings.
- U. Fill voids with approved backfill materials as shoring bracing and sheeting is removed.
- V. All underground copper tubing shall be double polyethylene encased in sleeves, 10-mil minimum thickness, and all openings in the sleeves shall be taped shut with Polyken #900 Tape Wrap or approved equal.

3.07 INSPECTION & TESTING AT TRENCHES

- A. Pipe will be inspected in the field before and after laying. If any cause for rejection is discovered in a pipe after it has been laid, it shall be subject to rejection. Any corrective work shall be approved by the Engineer and shall be at NO cost to the Owner.

- B. The Inspector or Geotechnical Engineer will inspect all subgrades and excavations prior to placing bedding & backfill materials.
- C. **DO NOT** place backfill until the bedding and pipe work installed has been inspected, tested and approved by the Inspector. Remove excavated rocky material unsuitable for backfill from the site prior to final backfilling.
- D. Utility backfill compaction test shall be performed in accordance with ASTM D1557, method "C".
- E. Utility backfill in place density test per ASTM D 1556 (sand cone) or other test method as considered appropriate by the Geotechnical Engineer.
- F. Hydrostatic pressure tests shall be done only after backfill has been placed and final compaction has been achieved.

3.08 APPROVAL OF SUBGRADE

- A. Notify Geotechnical Engineer when excavations have reached required over-excavation subgrade.
- B. When Geotechnical Engineer determines that unforeseen unsatisfactory soil is present, continue work only after receiving direction from the Contracting Officer.
- C. Reconstruct subgrades damaged by rain, accumulated water or construction activities as directed by the Soils Engineer.

3.09 UNAUTHORIZED EXCAVATION

- A. Fill of unauthorized excavation below bottoms of foundations or wall footings will be engineered fill.
- B. Fill unauthorized excavations under other construction as directed by the Soils Engineer.
- C. Where indicated widths of utility trenches are exceeded, provide stronger pipe, or special installation procedures, as required by the Geotechnical Engineer.

3.10 STORAGE OF SOIL MATERIALS

- A. After the site has been stripped of all debris, vegetation and organic materials, excavated on site soils may be reused as engineered fill provided they meet the satisfactory soils material conditions in Section 2.01, part D. High in-site moisture contents will require aeration prior to placement as engineered fill.
- B. Stockpile excavated materials acceptable for backfill and fill soil materials, including acceptable borrow materials. Stockpile soil materials without intermixing. Place, grade, and shape stockpiles to drain surface water. Stockpile soil materials away from edge of excavations. Do not store within drip line of remaining trees. Cover to prevent wind-blown dust.

3.11 PLACEMENT OF ENGINEERED FILL

- A. Preparation of the bottom of the excavation:
1. Prior to placement of compacted fill, the contractor should request an evaluation of the exposed excavation bottom by the geotechnical representative.
- B. Spreading and Compacting Fill Material:
1. Prior to compaction, each lift should be watered or dried as needed to achieve near optimum moisture condition, mixed, and then compacted by mechanical methods, using sheepsfoot rollers, multiple-wheel pneumatic-tired rollers, or other appropriate compacting rollers, to a relative compaction of 90 percent as evaluated using the latest version of ASTM D1557. Successive lifts should be treated in like manner until the desired finished grades are achieved.
- C. Compaction Testing:
1. The Geotechnical Engineer's representative shall observe the excavation, filling, and compacting operations and shall make density tests in the fill material so that he can state his opinion as to whether or not the fill was constructed in accordance with the specifications. If the surface is disturbed, the density tests shall be made in the compacted materials below the disturbed zone. When these tests indicate that the density or moisture content of any layer of fill or portion thereof does not meet the specified density or moisture content, the particular layer or portions shall be reworked until the specified density and moisture content have been obtained.
 2. Sampling and testing of materials for determination of compliance with the specified compaction requirements will be conducted by the Geotechnical Engineer's representative at any location and time as the Owner may determine.
 3. The Contractor shall be responsible for excavation of the test pits and for providing and installing any shoring, ladders, or other equipment necessary to protect the testing personnel. The Contractor shall also suspend operations as necessary and at no cost to the owner for the purpose of conducting such testing.
 4. Test pits shall be excavated in the backfill by the Contractor as directed by the Engineer for the purpose of testing the backfill compaction. At the option of Engineer, density tests may be taken on a lift of compacted backfill immediately before placing the next lift.
 5. Any settlement noted in backfill, fill, or in structures built over the backfill or fill within the one-year warranty period will be considered to be caused by improper compaction methods and shall be corrected at the Contractor's expense. Structures damaged by settlement shall be restored to their original condition by the Contractor at the Contractor's expense.
 6. When initial compaction testing performed by the Engineer indicates the required density has not been obtained, the Contractor shall re-compact or replace the backfill as necessary to meet the specified minimum density.
 7. The Contractor shall be responsible for rescheduling compaction testing with the Engineer and shall bear all costs for subsequent retesting in the areas of noncompliance. Costs

associated with retesting and scheduling delays shall be the sole responsibility of the Contractor. The Engineer will deduct the costs for testing of materials and work found to be unacceptable, as determined by the tests performed by the Owner and the costs for testing of material sources identified by the Contractor which are not used for the work, from moneys due or to become due to the Contractor. The amount deducted will be determined by the Engineer.

3.12 BACKFILL - GENERAL

- A. Backfill excavations promptly, but not before completing the following:
 - 1. Acceptance of construction below finish grade including, where applicable, dampproofing, waterproofing, and perimeter insulation.
 - 2. Surveying locations of underground utilities for record documents.
 - 3. Testing, inspecting, and approval of underground utilities.
 - 4. Concrete formwork removal.
 - 5. Removal of trash and debris from excavation.
 - 6. Removal of temporary shoring and bracing, and sheeting.
 - 7. Installing permanent or temporary horizontal bracing on horizontally supported walls.

3.13 GRADING

- A. Rough & Fine Grading: Rough grade area sufficiently high to require cutting by fine grading.
- B. General: Uniformly grade areas to a smooth surface, free from irregular surface changes. Comply with compaction requirements and grade to cross sections, lines, and elevations indicated.
 - 1. Provide a smooth transition between existing adjacent grades and new grades.
 - 2. Cut out soft spots, fill low spots, and trim high spots to conform to required surface tolerances.
 - 3. Grade area for paving to a depth below finish grades indicated, equal to base and pavement thickness to be constructed.
 - 4. Cut banks neatly to required finish grades as cut progresses, or leave cuts full and finish grading by mechanical equipment, which will produce finish grades indicated on Drawings.
 - 5. Grade filled banks full and compact beyond grade of finish bank so that when trimmed to finish grades, soil is compacted to density specified for final slope face.
 - 6. Bring areas to be graded to approximate finish grades and then scarify, moisten and roll to obtain required density. Scarify, moisten and roll resulting high and low areas to obtain required finish grades by cutting and filling.

7. Grade future planting areas so that, upon cultivation and fertilization, they will conform to finish grades indicated for planting areas.
 8. Protect all utilities.
- C. Site Grading: Slope grades to direct water away from buildings and to prevent ponding. Finish subgrades to required elevations within the following tolerances:
1. Building pad tolerance plus or minus ½ inch (0.05-foot).
 2. Lawn or Unpaved Areas: Plus or minus (0.10-foot).
 3. Walks: Plus or minus (0.04-foot).
 4. Pavements: Plus or minus (0.04-foot).
- D. Grading Inside Building Lines: Finish subgrade to a tolerance of ½ inch when tested with a 10-foot straightedge.

3.14 FIELD QUALITY CONTROL

- A. The CONTRACTOR shall provide an independent approved California Department of Health Services certified testing laboratory, to perform sampling and testing of import fill materials in accordance with the terms as specified in Section 01 45 24 – Environmental Import Materials Testing.
- B. Backfill and compaction of trenches in traffic areas must be in the presence of the project inspector or geotechnical engineer.
- C. A Geotechnical Engineer, designated by the Owner, will be engaged to perform continuous inspection of the placing and compacting of all fills and backfills within the limits of grading of this project. All work shall be done in accordance with the approved plans and these specifications and as recommended and approved by the Geotechnical Engineer. Revised recommendations relating to conditions differing from the approved soils engineering and engineering geology reports shall be submitted to the owner, inspector, architect and the civil engineer. Costs for all such inspections and tests shall be paid by the Owner. The Contractor shall be responsible for notifying the Geotechnical Engineer in advance so that he may be present to perform his services as needed.
- D. The Geotechnical Engineer shall submit compaction reports to the Construction Manager and the Architect at the completion of the work, including test results and plot plans indicating the locations from which the tested samples of fill were taken. The Geotechnical Engineer shall keep the Construction Manager informed on the progress of the grading work.
- E. Testing Agency Services: Allow testing agency to inspect and test each subgrade and each fill or backfill layer. Do not proceed until test results for previously completed work verify compliance with requirements.
1. Perform field in-place density tests according to ASTM D 1556 (sand cone method) or other test method as considered appropriate by Geotechnical Engineer.

- a. Field in place density tests may also be performed by the nuclear method according to ASTM D 2922, provided that calibration curves are periodically checked and adjusted to correlate to tests performed using ASTM D 1556. With each density calibration check, check the calibration curves furnished with the moisture gages according to ASTM D 3017.
 - b. When field in place density tests are performed using nuclear methods, make calibration checks of both density and moisture gages at beginning of work, on each different type of material encountered, and at intervals as directed by the Architect.
- 2. Paved and Building Slab Areas: At subgrade and at each compacted fill and backfill layer, perform at least one field in-place density test for every 2,000 sq. ft. or less of paved area or building slab, but in no case fewer than three tests.
- 3. Foundation Wall Backfill: In each compacted backfill layer, perform at least one field in place density test for each 100 feet or less of wall length, but no fewer than two tests along a wall face.
- 4. Trench Backfill: In each compacted initial and final backfill layer, perform at least one field in place density test for each 150 feet or less of trench, but no fewer than two tests.
- F. When testing agency reports that subgrades, fills, or backfills are below specified density, scarify and moisten or aerate, or remove and replace soil to the depth required, recompact and retest until required density is obtained.
- G. Owner's inspector will inspect foundation excavations when completed and ready for forms, after forms are in place, and before first placement of concrete.

3.15 PROTECTION

- A. Protecting Graded Areas: Protect newly graded areas from traffic, freezing, and erosion. Keep free of trash and debris.
- B. Repair and re establish grades to specified tolerances where completed or partially completed surfaces become eroded, rutted, settled, or lose compaction due to subsequent construction operations or weather conditions.
 - 1. Scarify or remove and replace material to depth directed by the Architect; reshape and recompact at optimum moisture content to the required density.
- C. Settling: Where settling occurs during the Project correction period, remove finished surfacing, backfill with additional approved material, compact, and reconstruct surfacing.
 - 1. Restore appearance, quality, and condition of finished surfacing to match adjacent work, and eliminate evidence of restoration to the greatest extent possible.

3.16 MAINTENANCE

- A. Install and maintain all erosion control devices, including sandbag and gravel bag dikes, silt fences, de-silting basins, inlet barricades, vehicle wash traps, and other features required per Section 01 57 23 Temporary Storm Water Pollution Control.
- B. Reconditioning Compacted Areas: Where completed compacted areas are disturbed by subsequent construction operations or adverse weather, scarify surface, re-shape to required tolerances, and compact to required density prior to further construction.

3.17 DISPOSAL OF SURPLUS AND WASTE MATERIALS

- A. Disposal: Remove surplus satisfactory soil and waste material, including unsatisfactory soil, trash, and debris, and legally dispose of it off the Owner's property.

END OF SECTION

SECTION 32 12 16
ASPHALT PAVING

PART 1 - GENERAL

1.1 REQUIREMENT

- A. The Contractor shall furnish all tools, equipment, materials, and supplies and shall perform all labor required to complete the work as indicated in the Contract Documents and specified herein.
- B. The following types of pavement shall be covered in this Section:
 - 1. Paving for utility trenching, parking lots, playgrounds, areas between buildings, adjacent to planting and turf areas, and as indicated on Construction Documents.
- C. Related Sections:
 - 1. Section 31 22 00: Grading.
 - 2. Section 32 12 36: Seal Coats.
 - 3. Section 32 17 23.13: Painted Pavement Markings.

1.2 WARRANTY

- A. The contractor shall provide a manufacturer's warranty against "aligatoring" and settlement.

1.3 QUALITY ASSURANCE

- A. The work provided herein shall conform to and be in accordance with the Contract Plans, General Conditions/Specifications and Special Provisions, as well as the Standard Specifications for Public Works Construction ("GREENBOOK"), 2018 Edition, adopted by the Southern California Chapter, American Public Works Association; herein referred to as the "Standard Specifications".
- B. The Owner's inspector shall test the temperature of each batch of asphaltic concrete prior to placement. At the time of delivery to the work site, the temperature of mixture shall not be lower than 260 degrees F or higher than 320 degrees F, the lower limit to be approached in warm weather and the higher in cold weather. If asphaltic concrete temperature is not within these tolerances the affected batch shall be rejected. Any and all costs due to the rejected asphaltic concrete shall be the responsibility of the paving contractor.

1.4 ESTABLISHMENT OF GRADES

- A. The Contractor's Surveyor will set grade stakes. The Surveyor shall be a California registered land surveyor or licensed Civil Engineer. The Surveyor shall be hired and paid by the Contractor, and shall be subject to the approval of the Owner. Contractor shall notify the Owner at least 48 hours before staking is to be started. The Owner will determine if work is ready for staking.

- B. All work shall conform to the lines, elevations, and grades shown on the Construction Plans. Three consecutive points set on the same slope shall be used together so that any variation from a straight grade can be detected. Any such variation shall be reported to the Engineer. In the absence of such report, the Contractor shall be responsible for any error in the grade of the finished work.
- C. Protect and maintain stakes in place until their removal is approved by the Owner. Grade or location stakes lost or disturbed by Contractor, shall be reset by the Surveyor at the expense of Contractor.
- D. Areas having drainage gradients of 2 percent or more shall have elevation stakes, set with instrument, at grid intervals of 25 feet. Intermediate stakes may be set by using a tightly-drawn string line over the tops of adjacent stakes. Grade stakes must be set at all grade breaks, grade changes, etc.
- E. Areas having drainage gradients of less than 2 percent shall have elevation stakes, set with instrument, at 10 foot intervals. Grade stakes must be set at all grade breaks, grade changes, etc.

1.5 SUBMITTALS

- A. Mix Designs: The CONTRACTOR shall formulate a job-mix formula using the Hveem method in accordance with Standard Specifications Section 203-6.2 and submit it to the ENGINEER for approval. The resultant mixture shall have Hveem properties conforming to Standard Specifications Section 203-6.4.3.
- B. Samples:
 - 1. Prior to the delivery of specified aggregate to the site, the CONTRACTOR shall submit samples of the material for the INSPECTOR's acceptance in accordance with Standard Specifications Section 4-1.4. Samples shall be typical of materials to be furnished from the proposed source and in conformance with the specified requirements.
 - 2. Aggregate base gradation and quality certifications shall be dated within 30 days of the submittal.
- C. Certificates
 - 1. Twenty days prior to the delivery of aggregates, asphalt materials, and paving mixes to the project site, the Contractor shall submit to the Engineer certificates and test results of compliance of such materials with these specifications.
 - 2. Submit certificates of compliance from the supplier for bituminous materials for paint binder, asphaltic concrete, and seal coat.
 - 3. Submit weigh master's certificates or certified delivery tickets for each truck load of asphaltic material delivered to the project site.
 - 4. Upon completion of the weed control treatment, and as a condition for final acceptance, furnish a written certificate stating the brand name of the sterilant and the manufacturer, and that the sterilant used had at least the minimum required

concentration, and that the rate and method of application complied in every respect with the conditions and standards contained herein.

1.6 QUALITY CONTROL

- A. Asphaltic Concrete Producers Qualifications: Use only materials furnished by a bulk asphaltic concrete producer regularly engaged in production of hot mix, hot laid bituminous concrete.
- B. Applicator Qualifications: Paving machine and roller operators shall be fully trained and experienced in the installation of asphaltic concrete paving on projects of similar size and complexity.
- C. Regulatory Requirements: The quantity of volatile organic compounds (V.O.C.) used in weed killer, seal coat, primer and other materials shall not exceed the limits permitted under the current regulations of the local authorities having jurisdiction.

1.7 ENVIRONMENTAL LIMITATIONS

- A. Do not apply asphalt materials if substrate is wet or excessively damp or if the following conditions are not met:
 - 1. Tack Coats: Minimum surface temperature of 60 deg F.
 - 2. Asphalt Base Course: Minimum surface temperature of 40 deg F and rising at time of placement.
 - 3. Asphalt Surface Course: Minimum surface temperature of 60 deg F at time of placement.

1.8 PAVEMENT-MARKING PAINT

- A. Proceed with pavement marking only on clean, dry surfaces and at a minimum ambient or surface temperature of 40 deg F for oil-based materials, 50 deg F for water-based materials, and not exceeding 95 deg F.

PART 2 - PRODUCTS

2.1 MATERIALS

- A. Base Course Material: Crushed aggregate base material shall consist of materials that meet the provisions of Specifications Section 31 22 00 Grading, Part 2.01F.
- B. Asphalt Surfacing Materials: Furnish asphalt surfacing meeting the following requirement, furnished from a commercial asphalt central mixing plant.
 - 1. Paint Binder/Tack Coat: Asphalt emulsion shall be CSS-1 or CSS-1h and shall conform to the requirements of Standard Specifications Section 203-3 Emulsified Asphalt.
 - 2. Asphalt Concrete Composition & Grading:
 - a. Asphalt concrete shall conform to Standard Specification Section 203-6.5.4, Type III-C3-PG-64-10.

- b. Rubberized asphalt paving is not allowed.
- C. Weed Control: Not required.
- D. Headers and Stakes:
 - 1. Headers: Pressure Treated Redwood, Construction Heart Grade, size 2 x 6, unless otherwise indicated on construction drawings
 - 2. Stakes: 2 x 4 redwood or 2 x 3 Douglas fir, Construction Grade.
 - 3. Nails: Common, galvanized, 12d minimum.

PART 3 - EXECUTION

3.1 HEADERS

- A. Install headers along edge of bituminous surfacing abutting turf, earth, or planting area, unless indicated otherwise.
- B. Install headers so the bottom surface has continuous bearing on solid grade. Where excavation for headers is undercut, thoroughly tamp soil under the header. Compact backfill on both sides of header to the density of adjacent undisturbed earth.
- C. Fasten headers in place with redwood or Douglas fir stakes of length necessary to extend into solid grade a minimum of 12 inches. Stakes shall be of sound material, neatly pointed, driven vertically, and securely nailed to headers. Space stakes, not to exceed 4 feet on centers with top of stakes set one inch below top of header. Provide a minimum of 2-12d galvanized common nails through each stake.
- D. Remove existing headers where new surfacing is installed adjacent to existing surfacing.
- E. Install temporary headers at transverse joints of paving where continuous paving operations are not maintained.
- F. Provide additional stakes and anchorage as required to fasten headers in place

3.2 SUBGRADE PREPARATION

- A. Subgrade Preparation.
 - 1. Refer to Detail 2A on sheet C003 of the construction documents.
 - 2. Prior to placement of compacted fill, the contractor should request an evaluation of the exposed excavation bottom by the Geotechnical representative.
- B. The compacted surface shall be firm, hard and unyielding. The term "firm, hard and unyielding" as used in S.S.P.W.C. Section 301-1.3 shall mean that when the heaviest construction and hauling equipment used on the project drives over the subgrade, no permanent deformation shall occur either before or during pavement construction. On areas where the underlying material appears to be wet or soft, or where it deflects under wheel

loads, the Contractor shall employ excavation and work techniques which do not worsen the subgrade condition.

- C. A California Licensed Surveyor (LS) must provide grade stakes and elevations for the Geotechnical Engineer to verify that the over-excavation depths, shown on the construction drawings for asphalt concrete pavement structural sections, have been achieved prior to re-compaction.
- D. Subgrade tolerances: Subgrade for pavement shall not vary more than 0.02' from the specified grade and cross section established by the Engineer. Subgrade for subbase or base material shall not vary more than 0.04' from the specified grade and cross section. Variations within the above specified tolerances shall be compensating so that the average grade and cross section specified are met.
- E. Correct irregularities by dressing down or filling as may be required, to bring areas to true subgrade elevations.
- F. Where filling is required, scarify the subgrade to bond the new material to the in place material; use additional material as required, subject to the approval of the Architect, and provided by the Contractor.
- G. Remove excess material from the site to a legal disposal area.

3.3 APPLICATION GENERAL

- A. Finish elevations, extent of asphalt paving and locations of type of asphalt and class of base shall be as indicated and specified herein and on the Construction Documents. Bring subgrade elevations sufficiently below the finish elevations of the paving so as to accommodate the thickness of paving and base.

3.4 APPLICATION OF BASE COURSE

- A. Install base course material, encompassing spreading and compacting, in accordance with the S.S.P.W.C. Section 301-2, Untreated Base.
- B. Aggregate bases material shall be installed in layers not exceeding 4-inches and compacted to a minimum of 95% relative density.
- C. After preparing the subgrade as specified in 3.2.A, all traffic on the subgrade shall be avoided. Should it be necessary to haul over the prepared subgrade, the CONTRACTOR shall drag and roll the traveled way as frequently as may be necessary to remove ruts, cuts, and breaks in the surface. All cuts, ruts, and breaks in the surface of the subgrade that are not removed by the above operations shall be raked and hand tamped. All equipment used for transporting materials over the prepared subgrade shall be equipped with pneumatic tires.
- D. Continued use of sections of prepared subgrade for hauling, so as to cut up or deform it from the true cross-section, will not be permitted. The CONTRACTOR shall protect the prepared subgrade from all traffic.

- E. Maintain the surface in its finished condition until the succeeding layer is placed.

3.5 PLACING ASPHALT CONCRETE SURFACING:

- A. Asphalt binder (tack coat) shall be applied to all existing pavement surfaces to be overlaid and/or joined per section 302-5.4 of the Standard Specifications. Asphalt binder (tack coat) shall be applied to existing surfaces to be surfaced and between layers of asphalt concrete, except when eliminated by the Engineer. A layer of asphalt binder (tack coat) shall be applied to all vertical-cut faces and between subsequent AC lifts.

- B. Asphalt Concrete Pavement:
 - 1. All work shall be in accordance with Section 302-5 of the Standard Specifications, except as noted herein. Asphalt concrete work shall include full-depth patching and variable thick asphalt concrete transition areas. The Contractor shall, on a daily basis, provide the Inspector with copies of certificates of weight for all materials delivered to the job site and/or incorporated in the work. At no time shall the coarse aggregate that has segregated from the mix be scattered across the paved mat.
 - 2. Asphalt concrete shall not be placed on any surface, which contains ponded water or excessive moisture in the opinion of the Engineer. If paving operations are in progress and rain or fog forces a shut down, loaded trucks in transit shall return to the plant, and no compensation will be allowed therefore. The Contractor shall furnish and use canvas tarpaulins to cover all loads of asphalt from the time that the mixture is loaded until it is discharged from the delivery vehicle, unless otherwise directed in writing by the Engineer
 - 3. The Inspector will examine the base before the paving has begun. The Contractor will correct any deficiencies before the paving is started.
 - 4. Wherever AC pavement does not terminate against a curb, gutter, or another pavement, the Contractor shall provide and install a redwood or pressure treated Douglas fir header at the line of termination.
 - 5. Pavement at all longitudinal joints shall have a Field Density of 95%, as described in 302-5.6.2 of the Standard Specifications. When the test results of the field cores are less than 95% Relative Compaction, the Contractor shall remove a 1 foot wide section on each side of the longitudinal joint. The Contractor shall replace the removed pavement with an asphalt mix that meets the job specification at no additional cost to the Owner.
 - 6. Pavement tolerances: within 1/8-inch of design thickness and 1/8-inch from design elevation.

3.6 FLOOD TESTING

- A. Flood Test: Before acceptance, all pavements shall be water tested to ensure proper drainage as directed by the Inspector. The Contractor shall provide water for this purpose. The flooding shall be done by water tank truck. Depressions where the water ponds to a depth of more than 1/8-inch shall be filled or the slope corrected to provide proper drainage. The edges of the fill shall be feathered and smoothed so that the joint between the fill and the original surface is invisible. No standing water shall remain after 30 minutes on a 70 degree F (or warmer) day.

3.7 SEAL COAT

- A. Allow new asphalt pavement to cure a minimum of 15 days before application of seal coat. See Project Specification Section 32 12 36: Seal Coats.

3.8 FIELD QUALITY CONTROL

- A. Thickness: Tolerances for asphalt pavement thickness shall be ¼ inch, plus or minus.
- B. All paving shall drain properly before being accepted. Upon completion, the pavement shall be true to grade and cross section. The asphalt substrate, shall not vary from the planned cross slope by more than +/- 0.1. When a 10 foot straightedge is laid on the finished surface of the asphalt, the surface shall not vary from the edge of the straightedge more than 1/8 inch, except at grade breaks. Where paving does not meet these tolerances, the paving material shall be repaired by a method determined by the Owner. Repairs shall not be made to pavement surface by feather-edging at the join lines. All expenses for pavement repair up shall be borne by the Contractor at NO cost to the Owner.
- C. Corrective Measures: It is the Contractor's responsibility to determine if the planarity, cross slopes, and general specifications have been met. If all of the conditions have been met the Contractor must notify the Owner in writing of the acceptance of the asphalt paving.

3.10 PROTECTION

- A. Protect the Work of this section until Substantial Completion.

3.11 CLEAN UP

- A. Clean all debris and unused materials from the paving operation. Clean all surfaces that have been spattered or defaced as a result of the paving operation. Asphalt or asphalt stains which are noticeable upon surfaces of concrete, or materials which will be exposed to view, shall be promptly and completely removed. Cleaning shall be done in a manner that will not result in any discharge of contaminated materials into any catch basin. All expenses for clean up shall be borne by the Contractor at NO cost to the Owner.

END OF SECTION

SECTION 32 12 36

SEAL COATS

PART 1 - GENERAL

1.01 SUMMARY

- A. Section Includes:
 - 1. Surface sealer over new asphalt paved surfaces.

1.02 REFERENCES

- A. Conform to Section 203 and 302 of the Standard Specifications for Public Works Construction.
- B. Comply with International Slurry Surfacing Association (ISSA) performance guidelines.

1.03 SUBMITTALS

- A. Product Data: Submit manufacturer's product information and application procedures for bituminous surfacing.

1.04 QUALITY ASSURANCE

- A. Comply with the following as a minimum requirement: Standard Specifications Section 203-9, "SEALCOAT – ASPHALT BASED".
- A. Obtain materials from same source throughout.
- B. Schedule a pre-construction conference at jobsite in advance of beginning of Work. In existing areas to be seal coated and restriped, document existing striping to be duplicated before commencing seal coating work.
- C. Review and resolve conflicts involving requirements of specifications. Record discussions and furnish copies to all attendees.
- D. Beginning of Work means Contractor accepts all conditions.
- E. Agitate bulk materials during transport.

1.05 REGULATORY REQUIREMENTS

- A. Comply with local air quality management district regulations for emissions maximums.
- B. Maintain control of vehicular and pedestrian traffic during seal coating operations as required for other construction activities and in accordance with local traffic authorities having jurisdiction.

PART 2 - PRODUCTS

2.01 MATERIALS

- A. Seal Coat: The materials for sealcoat shall conform to Section 203-9 – "Sealcoat – Asphalt Based" of the Standard Specifications. Before incorporation in the Work, the

Contractor shall submit a 2 Liter (2-quart) sample of undiluted seal coat at no cost to the Owner.

1. Seal Coat: Provide one of the following surface seals:

<u>Product Name</u>	<u>Manufacturer</u>
GuardTop	Vulcan Materials Company
Over Kote	Diversified Asphalt Product
Park Top	Western Colloid Products
Sure Seal	Asphalt Coating Engineering
MasterSeal	SealMaster Pavement Products & Equipment

- B. Crack Sealing: Crack sealant shall be CalSeal Modified Asphalt joint sealant as manufactured by Henry Inc, Crafcro Polyflex Type 3 or equal.

PART 3 - EXECUTION

3.01 REPAIRING AND SEALCOATING OF SURFACES

- A. Preparation of Surfaces:

1. Before placing the sealcoat, the pavement surface shall be cleaned by sweeping, flushing or other means necessary to removal all loose particles of paving, all dirt, and all other extraneous material. This shall include vegetation in pavement cracks and between pavement and curb/gutter. Prior to removal an approved herbicide, which leaves behind a visible blue marker dye, shall be sprayed where vegetation exists. Surface contaminates, grease or oil spots shall be cleaned to allow for proper adhesion.
2. Prior to applying sealcoat material, cracks wider then 1/8 inch shall be cleaned, treated with weed killer, and filled with an asphalt-based crack filler (large cracks may require several applications). For best quality, it is recommended that all broken asphalt be removed and patched with new asphalt. It is also suggested that extreme low spots be filled with new asphalt. New asphalt must cure 30 days before application of sealcoat.
3. Immediately before commencing the sealcoat operations, all surface metal utility covers (including survey monuments) shall be protected by thoroughly covering the surface with an appropriate adhesive and oiled or plastic paper. No adhesive material shall be permitted to cover, seal or fill the joint between the frame and cover of the structure. A vertical tab shall be placed on each cover for locating after the seal application is complete. The tab shall extend at least 3" above the existing pavement surface. Covers are to be uncovered and cleaned of asphalt emulsion material by the end of the same work day. Inspector shall inspect surfaces before the installation of seal coat.
4. For best results, the asphalt, just prior to being sealed, should be sprayed with a mist of water in an amount that will leave the surface damp but with no puddles

or visible water. This procedure is critical when ambient temperature is hot with bright sunlight or when the pavement is excessively aged or porous.

5. A prime or tack coat may be necessary on surfaces that have weathered excessively or are dusted. The primer should be diluted with three parts clean, potable water and one part SS-1h emulsion and shall be applied at the rate of 0.05 gallon per square yard.
6. Install barricades as required to divert traffic from operations. Install temporary “no parking” signs and similar notices.

B. Application:

1. Sealcoat may be mixed with water to obtain desired consistency for job requirements to a maximum of 20% of the total volume. Care should be taken not to over dilute. Material after dilution shall be mixed with a mechanical agitator to maintain consistency and ease of application. Note that as the pavement increases in roughness, the amount of dilution should be decreased.
2. Sealcoat shall only be applied when the atmospheric temperature is greater than 55 degrees F and if rain is not forecast for the period of 24 hours after application.
3. The sealcoat material shall be applied in two applications. Unless otherwise specified, the total quantity applied (before dilution) shall be 50 gallons per 1,000 square feet.
4. Sealcoat material shall be applied using a truck-mounted tank or wheeled container in continuous parallel lines and spread by means of brooms or rubber-faced squeegees either by hand or machine and in such a manner as to eliminate all ridges, lap marks, and air pockets.
5. Hand tools shall be available in order to remove spillage. Ridges or bumps in the finished surface will not be permitted. Sealcoat material shall be homogeneous prior to spreading, with no visible separation of solids and liquids.
6. When the first coat has completely dried to the touch, apply the second coat. While misting is not normally required before second coat, surface should be clean with no foreign materials on it.

C. Drying Time:

1. Sealcoat should be allowed to dry 24 – 48 hours before permitting traffic. When asphalt is cold or in shade, or air temperature is below 75 degrees F, based on general weather, humidity and temperature conditions, drying time may need to be extended.

3.02 CLEAN UP

- A. Remove rubbish, debris and waste materials and legally dispose of off the Project site.

- B. Striping for parking or traffic flow should be done only after the sealcoat has thoroughly dried. It is recommended that a high quality water based Traffic Line Paint be used for best results.

3.03 PROTECTION

- A. Protect the Work of this section until Substantial Completion.

END OF SECTION

SECTION 32 13 13
CONCRETE PAVING

PART 1 - GENERAL

1.01 THE REQUIREMENT

- A. The CONTRACTOR shall furnish all materials for concrete in accordance with the provisions of this Section and shall form, mix, place, cure, repair, finish, and do all other work as required to produce finished concrete, in accordance with the requirements of the Contract Documents.
- B. The following types of concrete shall be covered in this Section:
 - 1. Portland cement concrete pavement, cement walks, flatwork, curbs, gutters, retaining curbs, swales, trash pick-up areas, ramps, mowing strips, fence post footings, sliding gate concrete, catch basins, pipe bedding and encasements, transition structures, flagpoles and light standard bases and footings, splash blocks and equipment pads.
 - 2. Portland cement concrete paving shall be stable, firm and slip resistant and shall comply with CBC sections 11B-302 and 11B-403.

1.02 REFERENCE SPECIFICATIONS, CODES, AND STANDARDS

- A. Comply with the reference specifications of the GENERAL REQUIREMENTS.
- B. The work provided herein shall conform to and be in accordance with the Contract Plans, General Conditions/Specifications and Special Provisions, as well as the Standard Specifications for Public Works Construction (“GREENBOOK”), 2018 Edition, adopted by the Southern California Chapter, American Public Works Association; herein referred to as the “Standard Specifications” and the 2019 California Building Code.
- C. Comply with the current provisions of the following Codes and Standards.
 - 1. Federal Specifications:
 - a. UU-B-790A (Int.Amd. 1) Building Paper, Vegetable Fiber (Kraft, Waterproofed, Water Repellant and Fire Resistant).
 - 2. Commercial Standards:
 - a. ACI 214 Recommended Practice for Evaluation of Strength Test Results of Concrete.
 - b. ACI 301 Specifications for Structural Concrete for Buildings.
 - c. ACI 315 Details and Detailing of Concrete Reinforcement.
 - d. ACI 318-14 Building Code Requirements for Reinforced Concrete.

- e. ACI 347 Recommended Practice for Concrete Formwork.
- f. ACI 350 Recommended Practice for Sanitary Structure.
- g. ASTM C 31 Practices for Making and Curing Concrete Test Specimens in the Field.
- h. ASTM C 33 Specification for Concrete Aggregates.
- i. ASTM C 39 Test Method for Compressive Strength of Cylindrical Concrete Specimens.
- j. ASTM C 40 Test Method for Organic Impurities in Fine Aggregates for Concrete.
- k. ASTM C 42 Methods of Obtaining and Testing Drilled Cores and Sawed Beams of Concrete.
- l. ASTM C 78 Specification for Flexural Strength.
- m. ASTM C 88 Test Method for Soundness of Aggregates by use of Sodium Sulfate or Magnesium Sulfate.
- n. ASTM C 94 Specification for Ready-Mixed Concrete.
- o. ASTM C 114 Method for Chemical Analysis of Hydraulic Cement.
- p. ASTM C 131 Test Method for Resistance to Degradation of Small-Sized Coarse Aggregate by Abrasion and Impact in the Los Angeles Machine.
- q. ASTM C 136 Method for Sieve Analysis of Fine and Coarse Aggregate.
- r. ASTM C 143 Test Method for Slump of Portland Cement Concrete.
- s. ASTM C 150 Specification for Portland Cement.
- t. ASTM C 156 Test Method for Water Retention by Concrete Curing Materials.
- u. ASTM C 157 Test Method for Length Change of Hardened Hydraulic Cement Mortar and Concrete.
- v. ASTM C 172 Specification for Sampling Fresh Concrete.
- w. ASTM C 192 Method of Making and Curing Concrete Test Specimens in the Laboratory.
- x. ASTM C 260 Specification for Air-Entraining Admixtures for Concrete.
- y. ASTM C 289 Test Method for Potential Reactivity of Aggregates (Chemical Method).

- z. ASTM C 311 Method for Sampling and Testing Fly Ash or Natural Pozzolans for Use as a Mineral Admixture in Portland Cement Concrete.
- aa. ASTM C 494 Specification for Chemical Admixtures for Concrete.
- bb. ASTM C 618 Specification for Fly Ash and Raw or Calcined Natural Pozzolan for Use as a Mineral Admixture in Portland Cement Concrete.
- cc. ASTM C 979 Specification for Pigments for Integrally Colored Concrete
- dd. ASTM D 1751 Specification for Preformed Expansion Joint Fillers for Concrete Paving and Structural Construction (Non-extruding and Resilient Bituminous Types).
- ee. ASTM E 119 Method for Fire Tests of Building Construction and Materials.

1.03 CONTRACTOR SUBMITTALS

- A. Submittals shall be made in accordance with GENERAL REQUIREMENTS.
- B. The following submittals and specific information shall be provided.
 - 1. Mix Designs: Prior to beginning the WORK, the CONTRACTOR shall submit to the ENGINEER, for review, and approval, preliminary concrete mix designs for each class and type of concrete specified herein. The mix designs shall be designed by an independent testing laboratory acceptable to the ENGINEER. All costs related to such mix design shall be borne by the CONTRACTOR.
 - a. Each concrete mix submittal shall contain the following information:
 - 1) Slump on which the design is based.
 - 2) Total gallons of water per cubic yard.
 - 3) Brand, type, composition and quantity of cement.
 - 4) Brand type, composition and quantity of fly ash.
 - 5) Specific Gravity and gradation of each aggregate.
 - 6) Ratio of fine to total aggregate per cubic yard.
 - 7) Weight (surface dry) of each aggregate per cubic yard.
 - 8) Brand, type, and ASTM designation, active chemical ingredients and quantity of each admixture.
 - 9) Copy of the Building and Safety Research Report Approval for each concrete admixture.
 - 10) Air content.

- 11) Compressive strength based on 7 day and 28 day compression tests, including standard deviation calculations, corroborative data (if applicable), and required average comprehensive strength per ACI 318, Section 5.
 - 12) Time of initial set.
 - 13) Certification stamp and signature by a Civil or Structural engineer registered in state of California.
 - 14) Certificate of Compliance for Cement.
2. Certified Delivery Tickets: Where ready-mix concrete is used, the CONTRACTOR shall provide certified weighmaster delivery tickets at the time of delivery of each load of concrete. Each certificate shall show the public weighmaster's signature, and the total quantities, by weight of cement, sand, each class of aggregate, admixtures, and the amounts of water in the aggregate and added at the batching plant as well as the amount of water allowed to be added at the site for the specific design mix. Each certificate shall, in addition, state the mix number, total yield in cubic yards, and the time of day, to the nearest minute, corresponding to when the batch was dispatched, when it left the plant, when it arrived at the job, the time that unloading began, and the time that unloading was finished.
 3. When a water reducing admixture is to be used, the CONTRACTOR shall furnish mix designs for concrete both with and without the admixture.
 4. The CONTRACTOR shall furnish a Certificate of Compliance signed by the supplier identifying the type of fly ash and stating that the fly ash complies with ASTM C 618 and these Specifications, together with all supporting test data prior to the use of the fly ash the sample represents. The supporting data shall also contain test results confirming that the fly ash in combination with the cement and water to be used meets all strength requirements and is compatible with air-entraining agents and other admixtures.
 5. The CONTRACTOR shall submit to the ENGINEER for review the design mix for fly ash concrete together with the design mix for portland cement (non-fly ash) concrete as specified in this Section.

1.04 QUALITY ASSURANCE

- A. Testing for Portland Cement Concrete shall be sampled and tested in accordance with the ASTM and California Tests listed in the Standard Specifications for Public Works Construction, 2018 Edition, Section 201-1.1.5.
- B. Samples for strength tests of each class of concrete placed each day shall be taken not less than once a day, or not less than once for each 50 cubic yards of concrete, or not less than once for each 2,000 square feet of surface area for slabs. Additional samples for seven-day compressive strength tests shall be taken for each class of concrete at the beginning of the concrete work or whenever the mix or aggregate is changed.

- C. The cost of all laboratory tests on cement, aggregates, and concrete, will be borne by the CONTRACTOR.
- D. Concrete for testing shall be supplied by the CONTRACTOR at no cost to the Owner, and the CONTRACTOR shall provide assistance and facilities to the INSPECTOR in obtaining samples, and disposal and cleanup of excess material.
- E. Curbs and gutters shall be staked by a Land Surveyor licensed to practice in the State of California.
- F. Job Mock-Up
 - 1. General
 - a. Make samples on-site; revise as required; obtain Architect's approval, 10 days prior to casting finished work.
 - b. Finished work to match approved samples.
 - c. Approved sample may be incorporated into the work. Retain samples until completion of all concrete work.
 - d. Include typical tooled joint control in sample.
 - 2. Broom Finished Concrete; Exterior Flatwork: Provide sample, 20 s.f. minimum area.
 - 3. "Sacked" Vertical Surface; Exterior Wall: Provide sample, 5 sf. minimum area.
- G. Construction Tolerances: The CONTRACTOR shall set and maintain concrete forms and perform finishing operations so as to ensure that the completed work is within the tolerances specified herein. Surface defects and irregularities are defined as finishes and are to be distinguished from tolerances. Tolerance is the specified permissible variation from lines, grades, or dimensions shown. Where tolerances are not stated in the specifications, permissible deviations will be in accordance with ACI 347.
- H. Construction tolerances shall not violate dimensions, grades, slopes required by CBC for accessibility requirements. Adjust work accordingly to comply with requirements.
- I. The following construction tolerances are hereby established and apply to finished walls and slab unless otherwise shown:

Item	Tolerance
Variation of the constructed linear outline from the established position in plan.	In 10 feet: 1/8-inch; In 20 feet or more: 1/4-inch
Variation from the level or from the grades shown.	In 10 feet: 1/8-inch; In 20 feet or more: 1/4-inch
Variation from the plumb	In 10 feet: 1/8-inch;

	In 20 feet or more: 1/4-inch
Variation in the thickness of slabs and walls.	Minus 1/8-inch; Plus 1/4-inch
Variation in the locations and sizes of slabs and wall openings.	Plus or minus 1/8-inch

PART 2 - PRODUCTS

2.01 CONSTRUCTION MATERIALS

- A. Materials shall be delivered, stored, and handled so as to prevent damage by water or breakage. Only one brand of cement shall be used. Cement reclaimed from cleaning bags or leaking containers shall not be used. All cement shall be used in the sequence of receipt of shipments.
- B. All materials furnished for the work shall comply with the requirements of Sections 201, 203, and 204 of ACI 301, as applicable.
- C. Storage of materials shall conform to the requirements of Section 205 of ACI 301.
- D. Form Materials: Plywood, metal, metal-framed plywood, or other acceptable panel-type materials to provide full-depth, continuous, straight, smooth exposed surfaces. Conform to Section 303-5.2 of the Standard Specifications.
 - 1. Use flexible or curved forms for curves of a 100-foot or less radius.
- E. Reinforcing Materials: As follows:
 - 1. Steel Reinforcing Bars: ASTM A 615 deformed grade 40 billet steel, plain finish, unless otherwise specified on Construction Document. Fabrication, sampling and jobsite handling shall conform to the requirements in ASTM Designation: D 3963, except the 2 samples shall be 30 inches long.
 - 2. Dowels:
 - a. Dowel bars shall be plain round smooth conforming to the requirements in ASTM Designation: A 615/A 615M, Grade 40 except that the two samples required in ASTM Designation: D 3963/D 3963M shall be 18 inches long. Dowel bars shall be free from burrs or other deformations detrimental to free movement of the bars in the concrete
 - b. Dowel bars shall be lubricated with a bond breaker over the entire bar. A bond breaker application of petroleum paraffin based lubricant or white-pigmented curing compound shall be used to coat the dowel bars completely prior to placement. Oil and asphalt based bond breakers shall not be used. Paraffin based lubricant shall be Dayton Superior DSC BB-Coat or Valvoline Tectyl 506 or an approved equal. Paraffin based lubricant shall be factory applied. White pigmented curing compound

shall conform to the requirements of ASTM Designation: C 309, Type 2, Class A, and shall contain 22 percent minimum nonvolatile vehicles consisting of at least 50 percent paraffin wax. Curing compound shall be applied in 2 separate applications, the last application not more than 8 hours prior to placement of the dowel bars. Each application of curing compound shall be applied at the approximate rate of one gallon per 15 square yards.

3. Epoxy for bonding tie bars and dowel bars to portland cement concrete shall be a two-component, epoxy-resin, conforming to the requirements of ASTM Designation: C 881, Type V, Grade 3 (Non-Sagging), Class B or C. The class used shall be dependent on the internal temperature of the hardened concrete at the time the epoxy is to be applied. Class B shall be used when the internal temperature is from 40 °F to 60 °F. Class C shall be used when the internal temperature is above 60 °F, but not higher than recommended by the manufacturer. A copy of the manufacturer's recommended installation procedure shall be provided to the Engineer at least 7 days prior to the start of work. Epoxy shall be applied in conformance with the manufacturer's recommendations.
 - a. Simpson Strong-Tie Set-XP Epoxy Adhesive (or approved equal) ICC-ES ESR-2508.

F. Concrete Materials: As follows:

1. Cement shall be standard brand portland cement conforming to ASTM C 150 for Type II. Portland cement shall contain not more than 0.60 percent alkalis. The term "alkalis" referred to herein is defined as the sum of the percentage of sodium oxide and 0.658 times the percentage of potassium oxide ($\text{Na}_2\text{O} + 0.658 \text{K}_2\text{O}$). These oxides shall be determined in accordance with ASTM C 114. A single brand of cement shall be used throughout the work, and prior to its use, the brand shall be acceptable to the ENGINEER. The cement shall be suitably protected from exposure to moisture until used. Cement that has become lumpy shall not be used. Sacked cement shall be stored in such a manner so as to permit access for inspection and sampling. Certified mill test reports for each shipment of cement to be used shall be submitted to the INSPECTOR.
2. Concurrent with strength design criteria, concrete shall also be proportioned to provide the requisite durability to satisfy the exposure conditions imposed by either environment and/or service. Durability, in this context, refers to the ability of the concrete to resist deterioration from the environment or service in which it is placed. Concrete proportioned in accordance with ACI 318, chapter 4, Durability Requirements, will meet this criteria.
3. Combined Aggregate: 1" maximum coarse aggregate size conforming to Grading C of Standard Specifications Section 201-1.3.2(A). Aggregates shall be obtained from pits acceptable to the INSPECTOR, shall be non-reactive, and shall conform to ASTM C 33.

4. Water: Shall be potable, clean, and free from objectionable quantities of silty organic matter, alkali, salts and other impurities. The water shall be considered potable, for the purposes of this Section only, if it meets the requirements of the local governmental agencies.
5. *“Pea gravel” mix is not acceptable*, unless specifically approved in writing by the Civil Engineer of Record prior to construction.

G. Admixtures:

1. The ENGINEER may require the use of admixtures or the CONTRACTOR may propose to use admixtures to control the set, effect water reduction, and increase workability. In either case, the addition of an admixture shall be at the CONTRACTOR's expense. The use and continued use of an admixture shall be approved by the ENGINEER. Admixtures specified herein, other than calcium chloride, shall conform to the requirements of ASTM C 494. The required quantity of cement shall be used in the mix regardless of whether or not an admixture is used. Admixtures shall contain no free chloride ions, be non-toxic after 30 days, and shall be compatible with and made by the same manufacturer as the air entraining admixture.
2. These admixtures shall not be used in greater doses than those recommended by the manufacturer or permitted by the ENGINEER. The permitted dosage of the admixture shall not exceed that which will result in an increase in the driving shrinkage of the concrete in excess of 20 percent when used in precast or prestressed concrete, or 10 percent when used in any other structural concrete. The strength of concrete containing the admixture in the amount of proposed shall, at the age of 48 hours and longer be not less than that of similar concrete without the admixture. The admixture shall not adversely affect the specified air content, unless permitted by the ENGINEER.
3. Set controlling admixture shall be either with or without water-reducing properties. Where the air temperature at the time of placement is expected to be consistently over 80 degrees F, a set retarding admixture such as [Sika Chemical Corporation's Plastiment], [Master Builder's Pozzolith 300R], or equal shall be used. Where the air temperature at the time of placement is expected to be consistently under 40 degrees F, a set accelerating admixture such as [Sika Chemical Corporation's Plastocrete 161FL], [Master Builder's Pozzolith 50C], or equal shall be used.
4. Low range water reducer shall conform to ASTM C 494, Type A. It shall be either a hydroxylated carboxylic acid type or a hydroxylated polymer type. The quantity of admixture used and the method of mixing shall be in accordance with the manufacturer's instructions and recommendations.
5. High range water reducer shall be sulfonated polymer conforming to ASTM C 494, Type F or G.
 - a. If the high range water reducing agent is added to the concrete at the batch plant, it shall be second generation type, [Daracem 100, as

manufactured by W.R. Grace & Co.]; [Pozzolith 430R, as manufactured by Masterbuilders]; or equal. High range water reducer shall be added to the concrete after all other ingredients have been mixed and initial slump has been verified.

- b. If the high range water reducer is added to the concrete at the job site, it shall be used in conjunction with a low range water reducer and shall be [Pozzolith 400N and Pozzolith MBL82, as manufactured by Masterbuilders]; [WRDA 19 and WRDA 79, as manufactured by W.R. Grace & Co.]; or equal. Concrete shall have a slump of 3-inches \pm 1/2-inch prior to adding the high range water reducing admixture at the job site. The high range water reducing admixture shall be accurately measured and pressure injected into the mixer as a single dose by an experienced technician. A standby system shall be provided and tested prior to each day's operation of the job site system.
6. Air-entraining agent meeting the requirements of ASTM C 260, shall be used. Sufficient air-entraining agent shall be used to provide a total air content of 3 to 4 percent; provided that, when the mean daily temperature in the vicinity of the worksite falls below 40 degrees F for more than one day, the total air content provided shall be 5 to 6 percent. The Owner reserves the right, at any time, to sample and test the air-entraining agent received on the job by the CONTRACTOR. The air-entraining agent shall be added to the batch in a portion of the mixing water. The solution shall be batched by means of a mechanical batcher capable of accurate measurement.
7. Calcium Chloride: Except as otherwise provided herein, calcium chloride will not be permitted to be used in concrete.
8. Fly ash/pozzolan shall conform to ASTM C 618 and the following supplementary requirements:
- a. Class F fly ash
 - o Loss on ignition, maximum 4 percent
 - o SO₃ content, maximum 3 percent
 - o Moisture content, maximum 1 percent
 - b. Class F fly ash, as a percent by weight of total cementitious material, shall not exceed 15 percent.
 - c. When Sulfate Resistant or Special Exposure Concrete is specified, test results shall be submitted to the Engineer as specified in Section 2-5.3 of the Standard Specifications. The test result shall show that the fly ash to be used is effective in contributing to sulfate resistance in conformance with ASTM C618, Table 3 (optional physical requirements) as tested in accordance with ASTM C 1012. The data submitted shall be less than 6 months old.

H. Curing Materials:

1. Concrete curing compound shall conform to the requirements of ASTM C309 Type 1-D (clear or translucent with a fugitive dye), Class B (Resin Type Only), except the loss of water shall not exceed 0.15 kilograms per square meter in 24 hours nor 0.45 kilograms per square meter in 72 hours when tested in accordance with ASTM C 156. The CONTRACTOR shall provide, when requested by the ENGINEER, certified copies of vendor's test report showing compliance with ASTM C 309 and these specifications. The testing and the report shall be supplied without cost to the Agency. All compounds shall be furnished by the CONTRACTOR in sealed original containers labeled in accordance with ASTM C 309 and with the date of manufacture.
 2. Polyethylene sheet for use as concrete curing blanket shall be white and conform to ASTM C 171. The loss of moisture when determined in accordance with the requirements of ASTM C 156 shall not exceed 0.055 grams per square centimeter of surface.
 3. Polyethylene-coated burlap for use as concrete curing blanket shall conform to ASTM C 171. The loss of moisture, when determined in accordance with the requirements of ASTM C 156, shall not exceed 0.055 grams per square centimeter of surface.
- I. Expansion Joint Filler Material
1. Expansion Joint Filler: Nonextruding and Resilient Filler: Celotex "Flexcell", or approved equal, 3/8-inch thick material conforming to ASTM D 1751.
 2. Silicone Joint Sealant: Premium-grade, high-performance, moisture-cured, single-component, polyurethane-based, non-sag elastomeric sealant. Meets Federal specification TT-S-00230C. Meets ASTM C-920, Type S, Class 25 or 35; Grade NS, Use T or NT, Shore A Hardness (21 day) 35-45. A Certificate of Compliance for the silicone sealant shall be furnished to the Engineer. The Certificate shall also be accompanied with a certified test report of the results of the required tests performed on the sealant material within the previous 12 months prior to proposed use. The Certificate and accompanying test report shall be provided for each lot of silicone joint sealant prior to use on the project.
 - a. Sika Corporation, Sikaflex-1A or approved equal.
- J. Related Materials: As follows:
1. Damp-proofing agent shall be an asphalt emulsion, such as [Sonneborn Hydrocide 660], [Flintkote C-13-E Foundation Coating], or equal.
 2. Epoxy adhesives shall be the following products for the applications specified:
 - a. For bonding freshly-mixed, plastic concrete to hardened concrete, [Sikadur Hi-Mod Epoxy Adhesive, as manufactured by Sika Chemical Corporation]; [Concresive 1001-LPL, as manufactured by Adhesive Engineering Company]; or equal.

- b. For bonding hardened concrete or masonry to steel, [Colma-Dur Gel], [Sikadur Hi-Mod Gel], or equal.
- K. Flatwork Mix Design: At a minimum, site work concrete shall conform to the Standard Specifications for Public Works Construction, Section 201-1.1.2
 - 1. Compressive Strength: minimum of 2,500 psi at 28 days compressive strength.
 - 2. Slump Limit: 4 inches at point of placement.
 - 3. Air Content: 4% +/- 1% percent.
- L. Slurry Mix Design:
 - 1. Compressive Strength: 100 psi at min. 28 days compr. strength.
 - 2. Slump Limit: 5 inches at point of placement.
 - 3. Cement per cu yard (sacks): 1.0
 - 4. Aggregate Gradation: "E" per S.S.P.W.C. table 201-1.3.2(A).

PART 3 - EXECUTION

3.01 PREPARATION OF SURFACES FOR CONCRETING

- A. General: Earth surfaces shall be thoroughly wetted by sprinkling, prior to the placing of any concrete, and these surfaces shall be kept moist by frequent sprinkling up to the time of placing concrete thereon. The surface shall be free from standing water, mud, and debris at the time of placing concrete.
- B. Subgrade Preparation:
 - 1. Refer to Detail 1 on sheet C003 of the construction documents.
 - 2. Prior to placement of compacted fill, the contractor should request an evaluation of the exposed excavation bottom by the Geotechnical representative.
- C. The compacted surface shall be firm, hard and unyielding. The term "firm, hard and unyielding" as used in S.S.P.W.C. Section 301-1.3 shall mean that when the heaviest construction and hauling equipment used on the project drives over the subgrade, no permanent deformation shall occur either before or during pavement construction. On areas where the underlying material appears to be wet or soft, or where it deflects under wheel loads, the Contractor shall employ excavation and work techniques which do not worsen the subgrade condition.
- D. The above subgrade preparation recommendations are based on the assumption that soils encountered during field exploration are representative of soils throughout the site. However, there can be unforeseen and unanticipated variations in soils between points of subsurface exploration. For this reason, the actual scarification or over-

excavation depths will have to be determined on the basis of in-grading observations and testing performed by representatives of the project geotechnical consultant.

- E. A California Licensed Surveyor (LS) must provide grade stakes and elevations for the Geotechnical Engineer to verify that the over-excavation depths, shown on the construction drawings for concrete pavement structural sections, have been achieved prior to re-compaction.
- F. Joints in Concrete: Concrete surfaces upon or against which concrete is to be placed, where the placement of the old concrete has been stopped or interrupted so that, as determined by the ENGINEER, the new concrete cannot be incorporated integrally with that previously placed, are defined as construction joints. The surfaces of horizontal joints shall be given a compacted, roughened surface for good bond. Except where the Drawings call for joint surfaces to be coated, the joint surfaces shall be cleaned of all laitance, loose or defective concrete, and foreign material. Such cleaning shall be accomplished by sandblasting followed by thorough washing. All pools of water shall be removed from the surface of construction joints before the new concrete is placed.
- G. Embedded Items: No concrete shall be placed until all formwork, installation of parts to be embedded, reinforcement steel, and preparation of surfaces involved in the placing have been completed and ACCEPTED by the INSPECTOR at least 24 hours before placement of concrete. All surfaces of forms and embedded items that have become encrusted with dried grout from concrete previously placed shall be cleaned of all such grout before the surrounding or adjacent concrete is placed.
- H. All inserts or other embedded items shall conform to the requirements herein.
- I. All reinforcement, anchor bolts, sleeves, inserts, and similar items shall be set and secured in the forms where shown or by shop drawings and shall be acceptable to the INSPECTOR before any concrete is placed. Accuracy of placement is the responsibility of the CONTRACTOR.
- J. Where concrete is to be cast against old concrete, (greater than 60 days of age), the surface of the old concrete shall be thoroughly cleaned and roughened by sand-blasting, exposing the aggregate. In concrete shear-walls, suspended slabs and roof slabs, the interface surface at construction joints shall be roughened to a full amplitude of one quarter inch. The hardened surface shall be cleaned of all latent foreign material and washed clean, prior to the application of an epoxy bonding agent.
- K. No concrete shall be placed in any structure until all water entering the space to be filled with concrete has been properly cut off or has been diverted by pipes, or other means, and carried out of the forms, clear of the work. No concrete shall be deposited underwater nor shall the CONTRACTOR allow still water to rise on any concrete until the concrete has attained its initial set. Water shall not be permitted to flow over the surface of any concrete in such manner and at such velocity as will injure the surface finish of the concrete. Pumping or other necessary dewatering operations for removing ground water, if required, will be subject to the review of the ENGINEER.
- L. Corrosion Protection: Pipe, conduit, dowels, and other ferrous items required to be embedded in concrete construction shall be so positioned and supported prior to

placement of concrete that there will be a minimum of 2-inches clearance between said items and any part of the concrete reinforcement. Securing such items in position by wiring or welding them to the reinforcement will not be permitted.

- M. Openings for pipes, inserts for pipe hangers and brackets, and the setting of anchors shall, where practicable, be provided for during the placing of concrete.
- N. Anchor bolts shall be accurately set, and shall be maintained in position by templates while being embedded in concrete.
- O. Cleaning: The surfaces of all metalwork to be in contact with concrete shall be thoroughly cleaned of all dirt, grease, loose scale and rust, grout, mortar, and other foreign substances immediately before the concrete is placed.

3.02 HANDLING, TRANSPORTING, AND PLACING

- A. General: Placing of concrete shall conform to the applicable requirements of ACI 301 and the requirements of this Section.
- B. The total elapsed time between the addition of water at the batch plant and the completion of the discharge of the P.C.C. from the mixer shall not exceed 90 minutes. All P.C.C. remaining in the mixer after said 90-minute time limit shall be rejected and removed from the project site.
- C. Non-Conforming Work or Materials: Concrete which upon or before placing is found not to conform to the requirements specified herein shall be rejected and immediately removed from the work. Concrete which is not placed in accordance with these Specifications, or which is of inferior quality, shall be removed and replaced by and at the expense of the CONTRACTOR.
- D. Whenever batch trucks or other paving equipment cause rutting of the subgrade or subbase in concrete placement areas, inspectors shall immediately stop construction. Construction shall not be allowed to resume until distorted subgrade or subbase is repaired. Contractors and inspectors should locate by proof rolling, any questionable unstable areas in advance to avoid distortion under equipment. Wet, unstable areas must be dried out or replaced before starting placement of asphalt. Locating wet or soft areas in advance can be accomplished by testing finished subgrade or subbase with a loaded truck. Construction of concrete pavement should not proceed unless testing gives a reasonable indication that distortions will not occur during construction of overlying pavement. When repair, aeration, and recompaction are required to correct damage from Contractor's operation, all necessary repair will be done at Contractor's expense. However, if the Engineer determines that additional depth of aeration and recompaction are needed, that should be paid by change order.
- E. All pull boxes, meter boxes, valve covers and manholes shall be adjusted to proposed finish grade prior to placement of the P.C.C.
- F. Dowel Placement:

1. Dowel bars shall be centered on the joint within a tolerance of ± 2 inches in the longitudinal direction directly over the contact joint or sawcut for the transverse weakened plane joints, as shown on the plans. Prior to placement of dowel bars, the Contractor shall submit to the Engineer a written procedure to identify the transverse weakened plane joint locations relative to the middle of the dowel bars and the procedure for consolidating concrete around the dowel bars.
 2. Dowel bars shall be placed at longitudinal joints as shown on the plans. Dowel bars shall be placed as shown on the plans by using mechanical insertion. When dowel bars are placed by mechanical insertion, the concrete over the dowel bars shall be reworked and refinished so that there is no evidence on the surface of the completed pavement that there has been any insertion performed. When drill and bonding of dowel bars is performed at contact joints, a grout retention ring shall be used.
- G. Concrete shall not be placed until the forms and reinforcement have been inspected, all preparations for the placement have been completed, and the preparations have been checked by the project inspector, all subject to the observation of the engineer or architect.
- H. Casting New Concrete Against Old: An approved epoxy adhesive bonding agent shall be applied to the old surfaces according to the manufacturer's written recommendations. This provision shall not apply to joints where waterstop is installed.
- I. Conveyor Belts and Chutes: All ends of chutes, hopper gates, and all other points of concrete discharge throughout the CONTRACTOR'S conveying, hoisting and placing system shall be so designed and arranged that concrete passing from them will not fall separated into whatever receptacle immediately receives it. Conveyor belts, if used, shall be of a type acceptable to the INSPECTOR. Chutes longer than 50 feet will not be permitted. Minimum slopes of chutes shall be such that concrete of the specified consistency will readily flow in them. If a conveyor belt is used, it shall be wiped clean by a device operated in such a manner that none of the mortar adhering to the belt will be wasted. All conveyor belts and chutes shall be covered. Sufficient illumination shall be provided in the interior of all forms so that the concrete at the places of deposit is visible from the deck or runway.
- J. Placement in Slabs: Concrete placed in sloping slabs shall proceed uniformly from the bottom of the slab to the top, for the full width of the pour. As the work progresses, the concrete shall be vibrated and carefully worked around the slab reinforcement, and the surface of the slab shall be screeded in an up-slope direction.
- K. Temperature of Concrete: The temperature of concrete when it is being placed shall be not more than 90 degrees F nor less than 40 degrees F in moderate weather, and not less than 50 degrees F in weather during which the mean daily temperature drops below 40 degrees F. Concrete ingredients shall not be heated to a temperature higher than that necessary to keep the temperature of the mixed concrete, as placed, from falling below the specified minimum temperature. If concrete is placed when the weather is such that the temperature of the concrete would exceed 90 degrees F, the

CONTRACTOR shall employ effective means, such as precooling of aggregates and mixing water using ice or placing at night, as necessary to maintain the temperature of the concrete, as it is placed, below 90 degrees F. The CONTRACTOR shall be entitled to no additional compensation on account of the foregoing requirements.

- L. Cold Weather Placement: Earth foundations shall be free from frost or ice when concrete is placed upon or against them. Fly ash concrete shall not be placed when the air temperature falls below 50 degrees F.
- M. A transverse construction joint shall be constructed, including dowel bars, at the end of each day's work or where concrete placement is interrupted for more than 30 minutes, to coincide with the next contraction joint location. If sufficient concrete has not been mixed to form a slab to match the next contraction joint, when an interruption occurs, the excess concrete shall be removed and disposed of back to the last preceding joint. The cost of removing and disposing of excess concrete shall be at the Contractor's expense. Excess material shall become the property of the Contractor and shall be disposed of. A metal or wooden bulkhead (header) shall be used to form the joint. The bulkhead shall be designed to accommodate the installation of dowel bars.
- N. Float Finish: Begin floating when bleed water sheen has disappeared and the concrete surface has stiffened sufficiently to permit operations. Float surfaces to true planes within a tolerance of 1/4 inch in 10 feet as determined by a 10-foot-long straightedge placed anywhere on the surface in any direction. The finished surface shall be free from humps, sags, blemishes or other irregularities cut down high spots and fill low spots. Refloat surface immediately to a uniform granular texture.
- O. Broom Finish Type:
 - 1. Surfaces Sloped Less than 6%: Provide a medium salt (medium broom) finish by drawing a soft bristle broom across concrete surface, perpendicular to line of traffic, to provide a uniform fine line texture.
 - 2. Surfaces Sloped greater than 6%: Provide a slip resistant (heavy broom finish) by striating surface 1/16 inch to 1/8 inch deep with a stiff-bristled broom, perpendicular to line of traffic.
- P. Joints:
 - 1. Joints: Joints in concrete curb, gutter and flatwork shall be designated as expansion joints and control joints. Joints for concrete flatwork shall be provided in spacing noted on the architectural plans. Expansion joints for curbs / curb & gutter shall be placed at no greater than 15 feet on center or as indicated on construction drawings.
 - a. Expansion Joints: Provide premolded joint filler, material meeting Section 2.01-I herein.
 - 1) Extend expansion joint fillers full-width and depth of joint, and 1/4" below finished surface where joint filler is indicated. If no

joint sealer is called for, place top of premolded joint filler flush with top of concrete or curb.

- 2) Where silicone joint sealer is noted on the construction documents, the premolded joint filler strips shall be placed 1" below the surface of the concrete or curb, the full width of the expansion joint. The remainder of all joints shall be filled to within 1/4" below the surface of the concrete with the silicone joint sealant.
- 3) Provide expansion joint filler strips, with elastomeric sealer, between p.c.c. walk and curb, p.c.c. walk and buildings, & p.c.c. walk and retaining walls and at locations noted on the construction documents. The depth of the filler strip shall be the depth of the p.c.c. walk plus 1 inch with the top set flush with the specified grade of the top of curb or walk.
- 4) Expansion joints in site work concrete shall comply with details on sheet C003.

b. Control Joints:

- 1) Control joints in site work concrete shall comply with details on sheet C003.

Q. Protection: In hot, dry, and windy weather protect concrete from rapid moisture loss before and during finishing operations with an evaporation-control film. Apply according to manufacturer's instructions after screeding and bull floating, but before floating.

3.03 LIGHT STANDARD BASES, FLAGPOLE BASES, POST BASES AND SIMILAR SITE STRUCTURES

- A. Forms: Suitable material and type, size, shape, quality and strength to insure construction as designed, true to line and sufficiently rigid to resist deflection during placing of concrete. Clean forms of all dirt, mortar and foreign matter before use.
- B. Reinforcement: Place accurately and hold in position, using metal chairs, spacers, metal hangers, supporting wires and other devices of sufficient strength to resist crushing under full load. Clean reinforcing steel of mortar, oil, dirt, loose mill scale loose or thick rust and coatings.
- C. Coordinate installation of conduits, cast in place items and other inserts.
- D. Finish: Grind or sack as required as determined by the Architect to produce a smooth, straight, plumb and acceptable finish without burrs or form marks. For horizontal surfaces: provide float finish.
- E. Curing: Cure surfaces utilizing one of the following methods:
 1. Spraying: Spray water over slab areas and maintain wet for 7 days.

2. Spread polyethylene film over slab areas, lapping edges and sides, minimum 6 inches and sealing with pressure sensitive tape; cover with plywood or otherwise protect film from damage; maintain in place for 7 days.
3. Apply liquid curing compound at rate of 200 square feet per gallon, using power sprayer equipped with agitator. Do not apply liquid curing compound to surfaces scheduled to receive paving units or finish of any kind.

3.04 TAMPING AND VIBRATING

- A. As concrete is placed in the forms or in excavations, it shall be thoroughly settled and compacted, throughout the entire depth of the layer which is being consolidated, into a dense, homogeneous mass, filling all corners and angles, thoroughly embedding the reinforcement, eliminating rock pockets, and bringing only a slight excess of water to the exposed surface of concrete during placement. Vibrators shall be high speed power vibrators (8000 to 10,000 rpm) of an immersion type in sufficient number and with (at least one) standby units as required.
- B. Care shall be used in placing concrete around waterstops. The concrete shall be carefully worked by rodding and vibrating to make sure that all air and rock pockets have been eliminated. Where flat-strip type waterstops are placed horizontally, the concrete shall be worked under the waterstops by hand, making sure that all air and rock pockets have been eliminated. Concrete surrounding the waterstops shall be given additional vibration, over and above that used for adjacent concrete placement to assure complete embedment of the waterstops in the concrete.
- C. Concrete in walls shall be internally vibrated and at the same time rammed, stirred, or worked with suitable appliances, tamping bars, shovels, or forked tools until it completely fills the forms or excavations and closes snugly against all surfaces. Subsequent layers of concrete shall not be placed until the layers previously placed have been worked thoroughly as specified. Vibrators shall be provided in sufficient numbers, with standby units as required, to accomplish the results herein specified within 15 minutes after concrete of the prescribed consistency is placed in the forms. The vibrating head shall be kept from contact with the surfaces of the forms. Care shall be taken not to vibrate concrete excessively or to work it in any manner that causes segregation of its constituents.

3.05 CURING

- A. Comply with 2019 California Building Code, Title 24, Part 2, Volume 2, Section 1905A.11.
 1. Begin final curing procedures immediately following initial curing and before concrete has dried. Continue final curing for at least seven (7) days in accordance with ACI 301 procedures. Avoid rapid drying at end of final curing period.
- B. Curing Methods: Perform curing of concrete by curing as herein specified.
 1. Provide moisture-curing by the following methods:

- a. Keep concrete surface continuously wet by covering with water.
 - b. Continuous water-fog spray.
 - c. Covering concrete surface with specified absorptive cover, thoroughly saturating cover with water and keeping continuously wet. Place absorptive cover to provide coverage of concrete surfaces and edges, with 4 inch lap over adjacent absorptive covers.
2. Provide curing and sealing compound to exposed exterior slabs, walks, and curbs, as follows:
- a. Apply specified curing and sealing compound to concrete slabs as soon as final finishing operations are complete (within 2 hours). Apply uniformly in continuous operation by power-spray or roller in accordance with manufacturer's directions. Re-coat areas subjected to heavy rainfall within 3 hours after initial application. Maintain continuity of coating and repair damage during curing period.
 - b. Do not use membrane curing compounds on surfaces which are to be covered with coating material applied directly to concrete, liquid, floor hardener, waterproofing, dampproofing, membrane roofing, flooring (such as ceramic or quarry tile, glue-down carpet), painting, and other coatings and finish materials, unless otherwise acceptable to Architect.
- C. Concrete slabs and paving shall be properly cured and protected against damage and defacement of nature during construction operations. If weather is hot or surface has dried out, spray surface with fine mist of water starting not later than two hours after final troweling. Surface of finish shall be kept continuously wet for at least ten days. Wetting is considered emergency work and shall be performed on weekends and holidays if necessary.
- D. The CONTRACTOR shall protect all concrete against injury or damage from excessive heat, lack of moisture, overstress, or any other cause until final acceptance by the Owner. Particular care shall be taken to prevent the drying of concrete and to avoid roughening or otherwise damaging the surface. Any concrete found to be damaged, or which may have been originally defective, or which becomes defective at any time prior to the final acceptance of the completed work, or which departs from the established line or grade, or which, for any other reason, does not conform to the requirements of the Contract Documents, shall be satisfactorily repaired or removed and replaced with acceptable concrete at the CONTRACTOR'S expense. Exclude traffic from concrete paving for at least 7 days after placement.
- E. Maintain concrete paving free of stains, discoloration, dirt, and other foreign material. Sweep concrete paving not more than 2 days prior to date scheduled for Substantial Completion inspections.

3.06 PUMPING OF CONCRETE

- A. General: If the pumped concrete does not produce satisfactory end results, the CONTRACTOR shall discontinue the pumping operation and proceed with the placing of concrete using conventional methods.
- B. Pumping Equipment: The pumping equipment must have 2 cylinders and be designed to operate with one cylinder only in case the other one is not functioning. In lieu of this requirement, the CONTRACTOR may have a standby pump on the site during pumping.
- C. The minimum diameter of the hose (conduits) shall be 4-inches.
- D. Pumping equipment and hoses (conduits) that are not functioning properly, shall be replaced.
- E. Aluminum conduits for conveying the concrete will not be permitted.
- F. Proportioning: Minimum compressive strength, cement content, and maximum size of aggregates shall be as specified herein.
- G. Gradation of coarse aggregates shall conform to ASTM C 33 and shall be as close to the middle range as possible.
- H. Gradation of fine aggregate shall conform to ASTM C 33, with 15 to 30 percent passing the number 50 screen and 5 to 10 percent passing the number 100 screen. The fineness modulus of sand used shall not be over 3.00.
- I. Water and slump requirements shall conform to the requirements of this Section.
- J. Cement and admixtures shall conform to the requirements of this Section.
- K. Field Control: Concrete samples for slump per ASTM C 143 and test cylinders per ASTM C 31 and C 39.

3.07 TREATMENT OF SURFACE DEFECTS

- A. As soon as forms are removed, all exposed surfaces shall be carefully examined and any irregularities shall be immediately rubbed or ground in a satisfactory manner in order to secure a smooth, uniform, and continuous surface. Plastering or coating of surfaces to be smoothed will not be permitted. No repairs shall be made until after inspection by the ENGINEER. In no case will extensive patching of honeycombed concrete be permitted. Concrete containing minor voids, holes, honeycombing, or similar depression defects shall have them repaired as specified herein. Concrete containing extensive voids, holes, honeycombing, or similar depression defects, shall be completely removed and replaced.
 - 1. All repairs and replacements herein specified shall be promptly executed by the CONTRACTOR at its own expense.
- B. Defective surfaces to be repaired shall be cut back from trueline a minimum depth of 1/2-inch over the entire area. Feathered edges will not be permitted. Where chipping or cutting tools are not required in order to deepen the area properly, the surface shall be prepared for bonding by the removal of all laitance or soft material, and not less than

1/32-inch depth of the surface film from all hard portions, by means of an efficient sandblast. After cutting and sandblasting, the surface shall be wetted sufficiently in advance of shooting with shotcrete or with cement mortar so that while the repair material is being applied, the surfaces under repair will remain moist, but not so wet as to overcome the suction upon which a good bond depends. The material used for repair purposes shall consist of a mixture of one sack of cement to 3 cubic feet of sand. For exposed walls, the cement shall contain such a proportion of Atlas white portland cement as is required to make the color of the patch match the color of the surrounding concrete.

- C. Holes left by tie-rod cones shall be reamed so as to leave the surfaces of the holes clean and rough. These holes then shall be repaired in an approved manner with non-shrink grout. Holes left by form-tying devices having a rectangular cross-section, and other imperfections having a depth greater than their least surface dimension, shall not be reamed but shall be repaired in an approved manner with non-shrink grout.
- D. All repairs shall be built up and shaped in such a manner that the completed work will conform to the requirements of this Section, as applicable, using approved methods which will not disturb the bond, cause sagging, or cause horizontal fractures. Surfaces of said repairs shall receive the same kind and amount of curing treatment as required for the concrete in the repaired section.
- E. Prior to filling any structure with water, all cracks that may have developed shall be repaired to the satisfaction of the ENGINEER. This repair method shall be done on the water bearing face of members. Prior to backfilling, faces of members in contact with fill, which are not covered with a waterproofing membrane, shall also have cracks repaired as specified herein.
- F. The finished surface shall be free from humps, sags, blemishes or other irregularities.

3.08 FIELD QUALITY CONTROL

- A. Correction of Mix Design for Failed Concrete Tests: If the compressive cylinder strength test for in place PCC yields test results below the specified 28-day PCC compressive strength and the Engineer determines a corrective change is necessary, the Contractor shall, at its own expense, make corrective changes in the mix proportions. The Engineer shall approve the changes in the mix proportions or PCC placement procedures, before any additional PCC is placed on the job.
- B. Flood Tests: Before final acceptance, and after concrete has thoroughly cured, all concrete pavement, including swales and curb & gutter, shall be water tested to ensure proper drainage as directed by the Inspector. The Contractor shall provide water for this purpose. The flooding shall be done by water tank truck. Concrete work where water ponds and does not run off in a reasonable amount of time (1-hour), shall be removed to the nearest score or joint line and replaced to provide proper drainage. Full compensation for complying with this requirement shall be considered as included in the Contract Unit Price for cement concrete pavement.

3.09 OFF-SITE CONCRETE WORK

- A. Concrete driveway aprons, street sidewalks, curbs and gutters, etc., indicated to be constructed outside of property lines shall conform to the standards and specifications of the public agency having jurisdiction and shall be subject to inspection by its representative. The CONTRACTOR shall obtain and pay for necessary permits and inspection fees. The Owner shall reimburse the Contractor for said permits and all necessary inspection fees.

3.10 CARE AND REPAIR OF CONCRETE

- A. General: The CONTRACTOR shall protect all concrete against injury or damage from excessive heat, lack of moisture, overstress, or any other cause until final acceptance by the Owner. Particular care shall be taken to prevent the drying of concrete and to avoid roughening or otherwise damaging the surface. Any concrete found to be damaged, or which may have been originally defective, or which becomes defective at any time prior to the final acceptance of the completed work, or which departs from the established line or grade, or which, for any other reason, does not conform to the requirements of the Contract Documents, shall be satisfactorily repaired or removed and replaced with acceptable concrete at the CONTRACTOR'S expense.
- B. The contractor shall barricade and protect placed Portland Cement Concrete from all damage, marks, mars and/or graffiti. Any Portland Cement Concrete damaged, defaced, discolored or defective shall be replaced at the contractor's expense.

END OF SECTION

SECTION 32 17 23.13
PAINTED PAVEMENT MARKINGS

PART 1 - GENERAL

1.01 REFERENCE:

- A. Related Sections:
 - 1. Section 32 12 16: Asphalt Paving.

1.02 DESCRIPTION:

- A. Principal Work Items Are:
 - 1. Painted lines, lettering, and symbols at parking areas.
 - 2. Painted stripes at exterior stairs.
 - 3. Fire Lane "No Parking."
 - 4. Curb marking and red curbs.

1.03 JOB CONDITIONS:

- A. Proceed with pavement marking only on clean, dry surfaces and at a minimum ambient or surface temperature of 40 deg F for oil-based materials, 50 deg F for water-based materials, and not exceeding 95 deg F.
- B. Sequencing, Scheduling: Coordinate with paving work. Verify that paint type is compatible with asphalt paving surfaces seal coats.
- C. Protection: Do not apply pavement markings for seven days after application of asphalt surface seal coat. After application, protect from traffic until thoroughly dry.

PART 2 - PRODUCTS

2.01 MATERIALS:

- A. Traffic Paint:
 - 1. Type: Water base, roadway traffic lane marking type; colors as selected.
 - 2. Acceptable Manufacturers:
 - a. Dunn-Edwards, Vin-L-Stripe No. W-801, vinyl-epoxy as a standard of quality.

- b. J. E. Bauer latex base Formula No. 1030A9 White, No. 1056A9 Yellow, No. 1865A9 Blue, No. 1118A9 Green, and No. 1854A9 Red.
- c. Sinclair No. 160 Vinyl Traffic Line Paint, water base.
- d. Ennis Traffic Safety Solutions.

PART 3 - EXECUTION

3.01 PREPARATION:

- A. Layout: Accurately measure and layout work. Use stencils for all work; snap lines for straight work.
- B. Prior to application of paint, allow the pavement to properly cure. Clean and prepare in accordance with paint manufacturer's written recommendations.
- C. Provide mechanical equipment to install paint in a uniform, straight or curved pattern, without holidays and other defects.
- D. Do not permit traffic until paint has completely cured.
- E. Provide two installations/applications of pavement marking; once for initial use and once after final seal coat.
- F. Install 2 coats in thickness recommended by manufacturer.

3.02 APPLICATION:

- A. Painted Lines, Lettering, and Symbols At Parking Areas:
 - 1. Parking Stall Lines: 4 inches wide, color white.
 - 2. Access aisles for accessible parking spaces shall be marked by a blue painted borderline around their perimeter. The area within the blue borderlines shall be marked with hatched lines a maximum of 36" on center in a color contrasting with that of the aisle surface, preferably blue or white. Access aisle markings may extend beyond the minimum required length. CBC Section 11B-502.3.3.
 - 3. Access aisles for passenger drop-off and loading zone shall be marked with a painted borderline around the perimeter. The area within the borderlines shall be marked with hatched lines a maximum of 36" on center in a color contrasting with that of the aisle surface. CBC section 11B-503.5.
 - 4. Color: White, for all work except blue at wheelchair accessible parking stalls borders and red at Fire Lanes.

5. Specific areas designated as fire lanes must be marked with red curbs using OSHA safety red paint. "FIRE LANE – NO PARKING" shall be painted on the top of curb in 3" white lettering at a spacing of 30' on center or portion thereof.
 6. Painted lines and markings on pavement at wheelchair accessible parking stalls shall be 4 inches wide (blue in color) equal of Color No. 15090 per Federal Standard 595C.
 7. Detectable warnings surfaces shall comply with CBC Section 11B-705.1.
 8. Detectable warning surfaces shall be yellow conforming to FS 33538 of Federal Standard 595C, except for locations at curb ramps, islands, or cut-through medians where color used shall contrast visually with that of adjacent walking surfaces, either light-on-dark, or dark-on-light. CBC Sections 11B-705.1.1.3 and 11B-705.1.1.5.
 9. Provide a minimum 5 year warranty on detectable warning surfaces per DSA Bulletin 10/31/02, revised 04/09/08.
- B. Stripes At Exterior Stairs:
1. Stripes: 2" wide, located 2" from, and parallel to, nosing.
 2. Required Locations: All treads, all top landings, all intermediate landings.

END OF SECTION

SECTION 33 14 16
SITE WATER DISTRIBUTION PIPING

WATER SERVICE NOTE: WATER SERVICE MUST BE MAINTAINED TO ALL USERS WITHIN THE CONSTRUCTION AREA AT ALL TIMES. IF THE PRIMARY SOURCE OF WATER IS INTERRUPTED, A TEMPORARY SECONDARY SOURCE SHALL BE SUPPLIED BY THE CONTRACTOR, APPROVED BY THE LOCAL WATER DEPARTMENT. ANY EXPENDITURES INCIDENTAL THERETO SHALL BE BORNE BY THE CONTRACTOR. THE WATER SHALL BE SAFE FOR DRINKING IN ACCORDANCE WITH PUBLIC HEALTH SERVICE DRINKING WATER STANDARDS.

PART 1 - GENERAL

1.01 SUMMARY

- A. This section describes general requirements, products, and methods of execution relating to domestic water systems serving all buildings and appurtenances. Unless otherwise noted, this section does not apply to irrigation or fire water systems and water systems inside of buildings.
- B. Contractor shall furnish all labor, materials, services, testing, transportation and equipment necessary for the completion of all plumbing and piping and including the demolition and removal of certain equipment, piping and appurtenances all as required and as indicated on drawings and specified herein. Work materials and equipment not indicated or specified which is necessary for the complete and proper operation of the work of this Section in accordance with the true intent and meaning of the contract documents shall be provided and incorporated at no additional cost to the Owner.
- C. Section Includes:
 - 1. Piping and specialties for underground domestic water outside the buildings.
 - 2. Trenching Requirements: Conform to the requirements of Section 31 22 00 – Grading.
 - 3. Hydrostatic Pressure, Leakage & Disinfection Testing.

1.02 SUBMITTALS

- A. Product Data: Manufacturer’s catalog data for materials. Include technical data for piping, gaskets, joints and couplings, gate valves and valve boxes, backflow preventers, tracer wire, detectable warning tape and backflow preventer enclosure.
- B. Certificates: Certificates attesting that tests set forth in referenced publications have been performed and the performance requirements have been satisfied.

1.03 LICENSES, PERMITS & FEES

- A. The Contractor installing the water lines shall have a Class “C-34”, “C-36” or Engineering “A” Contractors license valid in the State of California.

- B. The Contractor shall obtain all necessary permits, licenses, or agreements required by any legally constituted agency, pay for all fees and give all necessary notices required for the construction of the work. The School District shall reimburse the contractor for all necessary permits or inspection fees by any legally constituted agency.

1.04 QUALITY ASSURANCE

- A. California Plumbing Code, CPC, 2019 Edition.
- B. Comply with the following as a minimum requirement:
 - 1. ANSI:
 - a. ANSI B16.18 Cast Copper Alloy Solder Joint Pressure Fittings.
 - b. ANSI B18.5.2.1M Metric Round Head Short Square Neck Bolts.
 - 2. ASTM:
 - a. ASTM A 47 Ferric Malleable Iron Castings.
 - b. ASTM A 48 Gray Iron Castings.
 - c. ASTM A 53 Pipe, Steel, Black and Hit-Dipped, Zinc-Coated Welded and Seamless.
 - d. ASTM A 307 Carbon Steel bolts and Studs, 60,000 psi Tensile Strength.
 - e. ASTM A 563 Ductile Iron Castings.
 - f. ASTM A 563 Carbon and Alloy Steel Nuts.
 - g. ASTM B 61 Steam or Valve Bronze Castings.
 - h. ASTM B 62 Composition Bronze or Ounce Metal Castings.
 - i. ASTM B 88 Seamless Copper Water Tube.
 - j. ASTM C 94 Ready-Mixed Concrete.
 - k. ASTM D 1527 Acrylonitrile-Butadiene-Styrene (ABS) Plastic Pipe, Schedules 40 and 80.
 - l. ASTM D 1785 Poly Vinyl Chloride (PVC) Plastic Pipe, Schedules 40, 80 and 120.
 - m. ASTM D 2235 Solvent Cement for ABS Plastic Pipe, and Fittings.
 - n. ASTM D 2241 PVC Plastic Pipe Fittings, Schedule 40.
 - o. ASTM D 2282 ABS Plastic Pipe.
 - p. ASTM D 2466 PVC Plastic Pipe Fittings, Schedule 40.

- q. ASTM D 2468 ABS Plastic Pipe Fittings, Schedule 40.
 - r. ASTM D 2564 PVC Plastic Piping Systems.
 - s. ASTM D 2774 Underground Installation of Thermoplastic Pressure Piping.
 - t. ASTM D 2855 Making Solvent-Cemented Joints with PVC Pipe and Fittings.
 - u. ASTM D 3139 Joints Pressure Pipes Using Flexible Elastomeric Seals.
 - v. ASTM F 402 Safe Handling Of Solvent Cements, Primer and Cleaners Used for Joining Thermoplastic Pipes and Fittings.
 - w. ASTM F 477 Elastomeric Seals for Joining Plastic Pipes.
3. American Water Works Association (AWWA) Standards:
- a. AWWA C104/A21.4 Cement-Mortar Lining For Ductile-Iron Pipe and Fittings For Water
 - b. AWWA C110/A21.10 Ductile-Iron and Gray-Iron Fittings, 3 inches through 48 inches, for Water and Other Liquids.
 - c. AWWA C111/A21.11 Rubber-Gasket Joints for Ductile-Iron pressure Pipe and Fittings.
 - d. ASTM C151/A21.51-96 Ductile-Iron Pipe, centrifugally cast, for water 3 inches through 64 inches.
 - e. AWWA C153/A21.53 Ductile-Iron Compact Fittings, 3 inches through 16 inches, for Water and Other Liquids.
 - f. AWWA C500 Gate Valves for Water and Sewerage Systems.
 - g. AWWA C503 Wet- Barrel Fire Hydrants.
 - h. AWWA C508 Swing-Check Valves for Waterworks Service, 2 inches through 24 inches NPS.
 - i. AWWA C509 Resilient-Seated Gate Valves for Water and Sewerage Systems.
 - j. AWWA C511 Reduced-Pressure Principal Backflow-Prevention Assembly.
 - k. AWWA C600 Installation of Ductile-Iron Water Mains and Their Appurtenances.
 - l. AWWA C651 Disinfecting Water Mains.
 - m. AWWA C800 Underground Service Line valves and Fittings.

- n. AWWA C900 PVC Pressure Pipe, 4 inches through 12 inches, for Water Distribution.
- o. AWWA M23 PVC Pipe - Design and Installation.
- 4. Manufacturers Standardization Society (MSS) of the Valve and Fittings Industry:
 - a. MSS-SP-80 Bronze Gate, Globe, Angle and Check Valves.
 - b. MSS-SP-73 Silver Brazing Joints for Wrought and Cast Solder-Joint Fittings.
- 5. Uni-Bell PVC Pipe Association (UBPPA):
 - a. UBPPA UNI-PUB-9 Installation of PVC Pressure Pipe.
 - b. UBPPA UNI-B-13 Standard Performance Specification on joined restrained devices for use with Poly Vinyl Chloride (PVC) Pipe.
- C. The work provided herein shall conform to and be in accordance with the Contract Plans, General Conditions/Specifications and Special Provisions, as well as the Standard Specifications for Public Works Construction (“Green Book”), 2018 Edition.

1.05 SEQUENCING AND SCHEDULING

- A. Coordinate with other utility work.

1.06 PRODUCT HANDLING

- A. Store items above ground on platforms, skids or other approved supports.
- B. Deliver piping with factory-applied end-caps. Maintain end-caps through shipping, storage, and handling to prevent pipe-end damage and to prevent entrance of dirt, debris, and moisture.
- C. Store plastic piping protected from direct sunlight. Support to prevent sagging and bending.
- D. Handling: Use sling to handle valves and fire hydrants whose size requires handling by crane or lift. Rig valves to avoid damage to exposed valve parts. Do not use hand wheels or stems as lifting or rigging pongs.
- E. Protect coating and linings on pipes, fittings and accessories from damage. Do not drag pipe to trench. Repair coatings or linings damaged.

1.07 DISPOSAL OF REMOVED MATERIALS INCLUDING ASBESTOS-CEMENT PIPE

- A. All removed materials, except those indicated on the plans or described herein to remain the property of the Owner, shall become the property of the Contractor and shall be disposed in accordance with local, state, and federal laws. Should any of those materials be considered as hazardous the Contractor shall provide the Owners Inspector with paper custody trail documentation of the disposal.

- B. Asbestos – Cement (A-C) Pipe Removal and Disposal: The plans for the project may indicate that existing asbestos-cement pipe is to be removed from the ground. Where so indicated the Contractor shall excavate with care, expose the pipeline and remove the A-C pipe to the nearest joint. Should the plans not call out the removal of the A-C pipe and A-C pipe is encountered, the Contractor shall obtain approval from the Inspector as to whether or not the A-C pipe is to be removed or can be left in place. Cutting of the pipe shall only be done if absolutely there is no other way to expose the length of pipe to the nearest joint that be separated and the Inspector approves the cutting of the pipe. Cutting of the pipe shall be done with a mechanical saw with a pressure water source to dampen the pipe and the dust from the cutting. To remove a coupling, the coupling may have to be broken in the trench. The pipe once removed from the trench may be broken for handling. The breaking shall be done within a plastic bagging or sheeting material to minimize the release of asbestos fibers into the atmosphere. Once removed and broken, if necessary, the A-C material shall be bagged and disposed of legally with the Inspector to be given a copy of all Contractor paperwork as to the legal disposal of the material. If the A-C pipe section(s) are removed intact the pipe can be removed by the Contractor from the project site and become the property and responsibility of the Contractor.

1.08 DRAWINGS

- A. Because of the small scale drawings, it is not possible to indicate all offsets, fittings and accessories which may be required. The Contractor shall carefully investigate the conditions surrounding installation of his work, furnishing the necessary piping, fittings, valves, and other devices which may be required to complete the installation.
- B. The general arrangement indicated on the drawings shall be followed as closely as possible. Coordinate with the Architectural, Structural, Mechanical and Electrical Drawings prior to installation of piping fixtures and equipment to verify adequate space available for installation of the work shown. In the event a field condition arises which makes it impossible to install the work as indicated, submit, in writing, the proposed departures to the Architect for his acceptance. Only when Architect's acceptance is given, in writing, shall Contractor proceed with installation of the work.
- C. In case of a difference in the specifications or drawings, or between the specifications and the drawings or in the drawings, the Contractor shall figure the most expensive alternate and after award of contract, shall secure direction from the Architect.

1.09 EXAMINATION OF PREMISES

- A. Before bidding on this work, Contractors shall make a careful examination of the premises and shall thoroughly familiarize themselves with the requirements of the contract. By the act of submitting a proposal for the work included in this contract, the Contractor shall be deemed to have made such study and examination, and that he is familiar with and accepts all conditions of the site.

1.10 PROTECTION

- A. All work, equipment and materials shall be protected at all times. Contractor shall make good all damage caused either directly or indirectly by his own workmen. Contractor

shall also protect his own work from damage. He shall close all pipe openings with caps or plugs during installation. He shall protect all his equipment and materials against dirt, water, chemical and mechanical injury. Upon completion, all work shall be thoroughly cleaned and delivered in a new condition.

- B. Contractor shall be held responsible for all damage to equipment and materials until he has received written notice from the Architect or Engineer that his work has been accepted.

1.11 LOCATIONS

- A. The locations of apparatus, piping and equipment indicated on the drawings are approximate. Piping and equipment shall be installed in such a manner as to avoid all obstruction, preserve headroom, and keep openings and passages clear. The locations of and mounting heights of all fixtures shall be coordinated with the architectural plans and room elevations.
- B. Clearances and Openings: Contractor shall cooperate and coordinate his work with all other trades to avoid confliction and permit for a neat and orderly appearance of the entire installation. The Contractor shall, in advance of the work, furnish instructions to the General Contractor as to his requirements for equipment and material installation of any kind, whether or not specifically mentioned on drawings or in the specifications, and shall include recesses, chases in walls, and all required openings in the structure. Should furnishing this information be neglected, delayed or incorrect and additional cuttings are found to be required, the cost of the same shall be charged to this Contractor.

1.12 SUBMITTAL DATA

- A. Furnish, all at one time, prior to any installation, within the time noted below, six (6) copies of valid submittal data on all fixtures, material, equipment and devices. Each submitted item shall be indexed and referenced to these specifications and to put identification numbers on fixtures and equipment schedules.
- B. Manufacturer's submittal literature and shop drawings are required on all items to ensure the latest and most complete manufacturer's data is available for review. Requirements of the submittals and Engineer's submittal notes are a part of the work of this Division except that Engineer's notes may not be used as a means of increasing the scope of work of this Division.
- C. Submittals will be checked for general conformance with the design concept of the project but the review does not guarantee quantities shown and does not supersede requirements of this Division to properly install work.
- D. A list of names is not a valid submittal. To be valid, all submittals must:
 - 1. Be delivered to the Architect's office within thirty-five (35) days of award of the contract. Corrections or changes in submittals returned as inadequate or incomplete shall be accomplished within this time limit.
 - 2. Include all pertinent construction, installation, performance and technical data.

3. Have all copies marked to indicate clearly the individual items being submitted.
4. Have each item cross-referenced to the corresponding specified item and be marked to show how differences will be accommodated.
5. Contain calculations and other detailed data justifying how the item was selected for proposal. Data must be completed enough to permit detailed comparison of every significant characteristic for which the specified item was analyzed during design.
6. Include, for every item which differs in size, configuration, connections, service, accessibility or any other significant way, a drawing to the same (or larger) scale as to the pertinent portions of the contract drawings. In this drawing show a complete layout of the system except that which is identical to the contract drawings, unless the unchanged portions must be shown to indicate such things as clearances. This drawing, together with the contract design drawings must show the complete system as revised to accommodate the proposed alternate.
7. In addition to the material and equipment submittals, the Contractor shall provide shop drawings of all underground utilities complete with all appurtenances and indicate exact location by dimension to grading plan, submit for review prior to installation.

1.13 INSPECTION

- A. All work in the public right-of-way, including that within easements, shall be subject to inspection by the City of Monterey Park Water Department and shall be left uncovered until approved by the City Inspector. The contractor shall not proceed with any subsequent phase of work until the previous phase has been inspected and approved by the Inspector.
- B. Notice shall be given to the School District Inspector at least 48 hours before starting construction.
- C. Contractor shall not allow or cause any of his work to be covered up before it has been duly inspected, tested and approved by the Owner, Architect or any other authorized inspectors having legal jurisdiction over his work. Should he fail to observe the above, he shall uncover the work and, after it has been inspected, tested and approved, recover it at his own expense.
- D. Inspection of the work shall not relieve the contractor of any obligations to complete the work as prescribed by the standard specifications. Any known defective work shall be corrected before testing or final inspection will be permitted. Unsuitable materials may be rejected even if these materials have been previously overlooked by the Inspector.
- E. The Owner shall have the authority to suspend the work completely or in part for such time as it may deem necessary if the contractor fails to carry out instructions given by the Owner, or to perform any required provisions of the plans and specifications. The contractor shall immediately comply with a written order of the Owner to suspend the

work completely or in part. The work shall be resumed when improper methods or defective work are corrected as ordered and approved in writing by the Owner.

1.14 SUBSTITUTIONS

- A. The Contractor assumes full responsibility that alternate manufacturers, items and procedures will meet the job requirements and is responsible for cost of redesign and of modifications to this and other parts of work caused by alternate items furnished under work in this Section. In view of these responsibilities, it is the purpose of these specifications to establish procedures which ensure that the Contractor has considered all the ramifications of proposed alternates before submitting them for review. Submittals which do not comply with the requirements of these specifications or which indicate proposed alternates were selected without proper regard to the requirements of the job, will not be approved. No more than one proposed alternate will be considered for each item.
- B. This Contractor is responsible to provide sufficient information to allow the Engineer to analyze any proposed alternate. If inadequate information is provided, the proposal will not be approved and resubmittal will not be allowed.
- C. The Architect or his authorized representative shall be the sole judge as to the quality and suitability of proposed alternate equipment, fixtures or materials and decisions of the Architect or that of his representative shall be final and conclusive.

1.15 RECORD DRAWINGS

- A. Contractor shall provide and keep up-to-date a complete "as-built" record set of redline prints which shall show every change from the original drawings and the exact "as-built" locations and sizes of the work provided under this Section of the specifications. This set shall include locations, dimensions, depth of buried piping, cleanouts, shut-off valves, sewer invert locations, plugged wyes, tees, etc. On completion of the work, the Contractor shall incorporate all as-built information on a set of reproducible tracings provided by the Architect and this set of reproducibles shall be delivered to the Architect.

PART 2 - PRODUCTS

2.01 MATERIALS

- A. Pipe (Below Grade):
 - 1. Domestic Water Pipe Schedule 80 PVC: Poly Vinyl Chloride (PVC) Plastic Pipe, Schedule 80, meeting ASTM D 1785 standards.
 - 2. Copper Tube (3 inches and smaller – Above grade):
 - a. Copper tubing with diameters 2-1/2" and 3" shall be seamless copper tube, Type K 'hard', drawn temper, meeting ASTM B 88 bearing NSF Standard 61 approval.

- b. Copper tubing up to 2" diameter, use Type K 'soft', annealed temper, ASTM B 88. Muller Brass, Cambridge-Lee Halstead, or equal.
 - c. All underground copper tubing shall be double polyethylene encased in sleeves, 10-mil minimum thickness, and all openings in the sleeves shall be taped shut with Polyken #900 Tape Wrap or approved equal.
- B. Fittings:
 - 1. Domestic Water Pipe Poly Vinyl Chloride (PVC) Water fittings shall conform to ASTM D 2467 "Socket-Type" PVC Plastic Type Fittings, Schedule 80.
 - 2. Brass Fittings: Bronze and brass 250 psi, screwed, A.S.A. B 16.17 and F S WW-P-460.
 - 3. Wrought Copper, Solder-Joint Pressure Fittings: Solder type ANSI B 16.22. Note: Pipe, solder, and flux shall be lead-free for drinking water. Flux shall be an approved water-soluble material. Threaded ends conforming to ASME B1.20.1.
- C. PVC & Mechanical Pipe Couplings, Joints and Jointing Materials.
 - 1. Pipe joints on plastic pipe 3-inch and under shall be solvent cement joints conforming to ASTM D 2564, primer according to ASTM F 656. Solvent and primer shall not be more than one year old.
- D. Soldered Filler Metal: Meeting ASTM B 32, Alloy Sn95.
- E. Brazing Filler Metal: Meeting AWS A5.8, BCuP-5, Silver Solder 1000 degrees F, Silvaloy 15, or equal.
- F. Soldering Fluxes: ASTM B813, liquid or paste type.
- G. Brazing Fluxes: ANSI/AWS A5.31, Type FB3-A or FB3-C. The use of brazing flux is not necessary if the components being joined are wrought copper tube.
- H. Dielectric Union:
 - 1. Brass union with 6-inch brass nipple.
 - 2. Union-flanged; Watts Model 3100, 3110, 3200 or approved equal.
- I. Gate Valves:
 - 1. Gate valves 2" or smaller: Valves shall be Class 200 WSP/WOG, stainless steel body and trim, threaded ends, inserted bonnet, solid disc.
 - a. Approved ball valve manufacturer / model:
 - 1) Red-White Valve Corporation #882.
 - 2. Gate valves 2.5" to 3": Valves shall be lead-free, bronze, conforms to MSS SP-139, non-rising stem, screw in bonnet, Class 125, 200 psi.

1) Nibco model T-113-LF.

J. Valve Boxes, Risers and Lids for Buried Valves:

1. Valve boxes and cover shall be as shown on Construction Documents.
2. Valve riser material shall be 10-inch Schedule 80 PVC, or 10-inch SDR 35 PVC pipe
3. Tops of boxes shall be set flush with finished turf grade or 2" above ground grades in shrubbery or groundcover areas.
4. Valve boxes shall be a concrete type with cast iron cover and name of service "WATER" clearly marked on cover.

PART 3 - EXECUTION

3.01 CLEARANCES OF WATER LINE

A. Buildings: 3 feet.

B. Parallel to Sewer Line:

1. Water lines 4 inches or less in diameter shall not be installed in a common trench with the building sanitary drain unless the bottom of the water line is at least 12 inches above the top of the building sanitary drain or where the water line is installed on a solid shelf excavated on one side of the common trench with a minimum clear horizontal distance of 12 inches from the building sanitary drain.
2. Water mains larger than 4 inches in diameter shall be separated from the Project site sanitary sewer, receiving more than one building sanitary drain or acid pipeline, in accordance with the requirement of the State of California, Human and Welfare Agency, Department of Health Services.

C. Crossing Sewer Line:

1. A water main shall be separated from sanitary sewer in accordance with the requirements of the State of California Administrative Code, Title 22, Section 64630(e)(2), unless modified herein.
2. Install water main a minimum of 12 inches clear, above or below a sanitary sewer.
3. A water main greater than 4 inches in diameter, crossing under a sanitary sewer line, shall be installed with all their joints located at least 10 feet away from each side of the sanitary sewer line.
4. A water main greater than 4 inches in diameter, crossing over a sanitary sewer line, shall be installed with all their joints located at least 5 feet away from each side of the sanitary sewer line.

- D. Install all water mains no closer than 10 feet horizontally clear from the edge of sewage leach fields, seepage pits and septic tanks.

3.02 LAYING OF PVC PRESSURE PIPE

- A. Installations of pipe, bends, and fittings shall be in accordance with the Uni-bell guideline UNI-PUB-9, "Installation Guide for PVC Pressure Pipe". Longitudinal bending of pipe sections is prohibited. A number 14 gauge, solid, soft drawn insulated copper tracer wire is required for PVC pipe installation. The tracer wire shall be wrapped around the pipe at 10-foot intervals and brought up inside each valve can to within 6 inches of the valve cover.
- B. Acceptable line and grade for piping: The pipe shall be laid true to the line and grade shown on the plans within acceptable tolerances. The tolerance on grade is 1 inch. The tolerance on line is 2 inches.
- C. Every precaution shall be taken to prevent foreign material from entering the pipe while it is being placed in the trench. If the pipe-laying crew cannot put the pipe into the trench and in place without getting soil into it, the Engineer may require that before lowering the pipe into the trench, a temporary plug be placed over each end and left there until the connection is to be made to the adjacent pipe. During the laying operations, no debris, tools, clothing or other materials shall be left in the pipe.
- D. At times when pipe laying is not in progress, the open ends of pipe shall be closed by watertight plug or other means approved by the Inspector. This provision shall apply during the lunch-hour breaks as well as overnight. If water is in the trench, the seal shall remain in place until the trench is pumped completely dry.
- E. The cutting of pipe for inserting tees, fittings or closure pieces shall be done in a neat workmanlike manner without damage to the pipe or cement lining and so as to leave a smooth end at right angles to the axis of the pipe. The beveled end of any PVC pipe shall be cut off before the pipe is inserted into a mechanical joint bend or fitting. No pipe shall be laid in water or when, in the opinion of the Engineer, trench conditions are unsuitable.
- F. All water piping shall be adequately supported. Burred ends shall be reamed to the full bore of the pipe or tube. Change in direction shall be made by the appropriate use of fittings. All piping, equipment, appurtenances and devices shall be installed in conformity with the provisions and intent of the California Plumbing Code.
- G. When connecting plastic pipe to copper, brass, or steel material, provide a schedule 80 PVC nipple.

3.03 LAYING OF COPPER PIPE

- A. Contractor shall follow the "Guide Specification for Copper and Copper Alloy Building Piping Systems", Revision 1, by the Copper Development Association Inc, available at: http://www.copper.org/pub_list/plumbing.html

- B. Soldered Joints: For copper tubing 1 inch and smaller construct joints according to ASTM B828.
- C. Brazed Joints: For copper tubing 1-1/4 inch and larger, for all below and above grade piping, construct joints according to ANSI/AWS C3.4.
- D. All underground copper tubing shall be double polyethylene encased in sleeves, 10-mil minimum thickness, and all openings in the sleeves shall be taped shut with Polyken #900 Tape Wrap or approved equal.
- E. Unions and Flanges: Ground joint, cast bronze unions for sizes 2 inch and smaller, 150-pound flange, cast brass, for sizes larger than 2 inches conforming to ANSI B16.24.

3.04 CONNECTIONS TO EXISTING UTILITIES

- A. All tie-in locations shall be excavated a minimum of TWO (2) working days in advance of final connection to expose the affected portions of existing pipelines and to allow time for the necessary measurements, assembling of materials and equipment, and assuring that all pre-assembled piping and fittings will be compatible with the existing main.
- B. Changes or delays caused by the Contractor's failure to perform "Potholing" and interference location work shall not be eligible for extra work, compensation, or time extension.
- C. The Contractor shall immediately notify the District Inspector in writing, upon learning of the existence or location of any utility facility omitted from or shown incorrectly on the contract drawings, or improperly marked or otherwise indicated. The Contractor shall provide full details as to depth, location, size and function of the utility in writing to the IOR and note it on the "as-built" plans.
- D. The Contractor shall not interrupt or disturb any utility facility in the public right-of-way without authority from the utility company or order from the City of Monterey Water Department.
- E. The Contractor shall furnish and place the necessary protection around a utility when protection is called for on the contract drawings, visible to the Contractor, or marked as such. The Contractor shall install the utility protection at no additional expense to the Owner.

3.05 VALVES

- A. Water valves shall be installed at locations shown on the Construction Drawing, or as directed by the Inspector. Valves shall be set plumb and shall be stabilized and supported separately from the pipeline. Information regarding size, type, make, and number of turns to close shall be supplied to the Utility. All valves shall be covered with a valve box assembly. Valve boxes shall be plumb, centered over the valve nut, and supported separately from the valve body. Valve boxes shall be lowered to below paving grade level prior to street paving, and after final grade has been established by the final grade. In any event, Contractor shall ensure that all valve boxes will provide

access to the operation of the valve by the Utilities' personnel. Valve boxes shall be flagged or barricaded during construction to divert traffic around their location.

- B. Wrap buried valves, 2-½ inches and larger, with two layers of 8-mil polyethylene wrap per AWWA C105.
- C. Stainless steel parts shall not be coated except for the threaded portion, which will be assembled with a liberal coat of anti-seize compound.

3.06 ELECTROLYSIS PREVENTION

- A. Insulating (dielectric) couplings or 6-inch long brass nipples shall be installed at locations specified or as required. Dielectric insulators shall be provided to insulate dissimilar metal to metal contact. Flanges shall be provided with a complete insulating component consisting of gasket bolt sleeves and bolt washers. Dielectric insulators shall be installed at locations indicated or as required.
- B. Where steel or cast iron below grade connects to copper or brass piping above grade, the transition from steel or cast iron pipe to copper or brass pipe shall be installed in an above grade accessible location.
- C. Underground dielectric connections shall be in accessible yard boxes.
- D. Above ground dielectric connections shall be exposed.

3.07 PIPELINE FLUSHING & HYDROSTATIC TESTING

- A. General Requirements
 - 1. Hydrostatic testing and disinfecting (chlorination and flushing) of newly laid or repaired pipelines and appurtenances must be completed before the pipelines can be connected to the existing water distribution system. Pipelines and appurtenances shall remain isolated from the existing water distribution system during hydrostatic testing and disinfecting.
 - 2. All services, air release valves, and other appurtenances connected to the newly laid pipeline shall be pressure tested and disinfected at the same time as that of the pipeline. Care shall be taken to expel all air from the pipeline and services during any filling operation.
- B. Temporary Piping and Appurtenances for Flushing, Testing, and Disinfecting
 - 1. The Contractor and/or subcontractor shall supply all temporary piping, corporation and curb stops, test plates, bulkheads, plugs, pipe end caps, valves, fittings, calibrated meters, equipment, labor and method necessary for pressure testing, chlorinating, and flushing of the newly laid pipeline. The Contractor shall also provide any temporary piping, backflow devices, and appurtenances needed to carry potable water to the section of pipeline being flushed, pressure tested, or disinfected.

2. Corporation and curb stop taps used for flushing, pressure testing, and disinfecting shall comply with service tap requirements for ductile iron pipe. Unless specified otherwise, the tap shall be made at the top of pipe.
- C. It is the responsibility of the Contractor to dispose of the flushed water from the project area. The Contractor shall take all precautions necessary in providing for adequate drainage from the site. The disposal of water is described later in this Section.

3.08 HYDROSTATIC (PRESSURE) TESTING FOR DOMESTIC WATER SYSTEM

- A. The Contractor shall hire a licensed independent subcontractor to conduct the required hydrostatic testing of newly laid pipelines. After completion of the hydrostatic testing, the subcontractor shall provide a signed copy of all test results to the Inspector. The Contractor and Inspector shall be present during the testing.
- B. Test PVC plastic water system in accordance with UBPPA UNI-B-3 for pressure and leakage. The amount of leakage from PVC piping shall not exceed the amounts given in UBPPA UNI-B-3, except that no leakage is permitted for joints installed with sleeve type mechanical couplings.
- C. Pressure testing: Before pressure test, fill portion of piping being tested with water for a minimum of 24 hours. Provide hydrostatic pressure of 50 psi greater than the maximum working pressure of tested system. Provide and maintain hydrostatic test pressure for at least 2 hours to ensure no leakage of any portion of piping or appurtenances under pressure test.
- D. Repetition of Hydrostatic Test: If the leakage in the section of pipeline being tested exceeds the maximum allowable rate specified above, such section will be considered defective. The Contractor shall determine the points of leakage and make the necessary repairs at his expense. The subcontractor will then conduct another hydrostatic test. This procedure shall be continued until the leakage falls below the allowed maximum.
- E. After Satisfactory Hydrostatic Test:
 1. All valves shall be tested for leak proof tightness after the pipeline hydrostatic test with the test pressure on one side of the valve and atmospheric pressure on the other side.
 2. After test sections have successfully met the hydrostatic test requirements to the satisfaction of the Inspector, the entire pipeline or each test section shall be filled or shall remain filled with potable water until the pipeline is disinfected. Test plates, corporation stops, and other test facilities shall remain in place if needed for disinfecting or removed as directed by Inspector.
 3. Regardless of the hydrostatic test results, the Contractor shall repair all detectable leaks.

3.09 DISINFECTION PROCEDURES

- A. All potable water lines MUST be disinfected per the following requirements.

- B. The Contractor shall supply all materials, labor, equipment and methods necessary to disinfect the water main. The Contractor shall hire a State certified laboratory to perform the required bacteriological tests for the newly laid pipelines.
- C. Preparation for Disinfecting Pipelines: Contractor shall tightly shut off every service connection served by the pipeline being disinfected at the curb stop before water is applied to the pipeline. Care should be taken to expel all air from the main and services during the filling operation.
- D. Inject solution of liquid chlorine or sodium hypochlorite and water containing at least 50 PPM of free chlorine into a system in a manner to ensure that entire system is completely filled with solution. During this procedure operate valves and test outlets for residual chlorine. Continue injection until outlets indicate at least 59 PPM of free chlorine.
- E. After injection, isolate system and hold solution in retention for a period of at least 8 hours. Perform tests for residual chlorine after retention. If such tests indicate less than 50 PPM of residual chlorine, repeat entire procedure. After satisfactory sterilization has been verified, flush entire system until all traces of chlorine have been removed or until chlorine content is no greater than in existing water supply.

3.10 DISPOSAL OF TEST WATER

- A. The disposal of all water used in flushing, hydrostatic testing, and disinfecting the sections of pipeline shall be the sole responsibility of the Contractor. The disposal of water shall, in all cases, be carried out in strict observance of the water pollution control requirements of the California Regional Water Quality Control Board.
- B. The Contractor shall obtain an NPDES permit and comply with that permit in his discharge of test water.
- C. The Contractor shall apply a reducing agent to the solution to neutralize residual chlorine or chloramines remaining in the water. Additionally, the flow of water from the sections of pipeline shall be controlled to prevent erosion of surrounding soil, damage to vegetation, altering of ecological conditions in the area, and damage to any construction or maintenance activity occurring in any ditch or storm drain downstream of discharge.

3.11 CONNECTING TO EXISTING DISTRIBUTION SYSTEM

- A. After all hydrostatic tests and disinfecting has been completed and demonstrated to comply with the Specifications, the Contractor shall connect newly laid pipeline to the existing distribution system.
- B. Where connections are to be made to an existing potable water system, swab or spray the interior surfaces of all pipe and fittings used in making the connections with a five (5) percent or greater hypochlorite solution as directed by the Inspector.
- C. As soon as the connection is completed, thorough flushing is required until all discolored water is removed.

3.12 REMOVAL OF TEMPORARY PIPING AND APPURTENANCES

- A. After the newly laid section of pipeline has been approved by the Inspector for connection to the existing distribution system, the Contractor shall disconnect and remove all temporary piping, fittings, test plates, backflow devices, and other appurtenances used for pressure testing, chlorinating, and flushing.
- B. Contractor shall remove and replace all stops used for testing and disinfecting of the pipeline with stainless steel repair clamps.

3.13 CLEANING

- A. Remove rubbish, debris, and waste materials and legally dispose of off the Project site.

3.14 PROTECTION

- A. Protect the Work of this section until Substantial Completion.

END OF SECTION

**SECTION 33 30 00
SANITARY UTILITIES**

PART 1 - GENERAL

1.1 SECTION INCLUDES

- A. Supply and installation of sanitary sewer system from building wall perimeter, unless noted otherwise, to site sanitary sewer point of connection as shown on Construction Documents.
- B. Sewage bypass and pumping plan.
- C. Spill prevention & emergency response plan.
- D. Closed-circuit television inspection of sewer laterals.
- E. Sewer Duplex Pump and Basin
- F. Contractor shall furnish all labor, materials, services, testing, transportation and equipment necessary for the completion of all piping and including the demolition and removal of certain equipment, piping and appurtenances all as required and as indicated on drawings and specified herein. Work materials and equipment not indicated or specified which is necessary for the complete and proper operation of the work of this Section in accordance with the true intent and meaning of the contract documents shall be provided and incorporated at no additional cost to the Owner.

1.2 RELATED SECTIONS

- A. Trenching Requirements: Conform to the requirements of Section 31 22 00 - Grading.

1.3 SUBMITTALS

- A. Product Data:
 - 1. Manufacturer's Catalog data for materials. Include technical data for pipe, gaskets, joints, couplings, pumps, pump basin, pump controller and all pump accessories, cleanout yard box with lid, sand bedding, tracer wire and detectable warning tape.
- B. Closeout Submittal: Submit three DVD's of Closed-circuit television inspections performed. Include the following information:
 - 1. Electronic Media Recordings: Visual and audio record of the entire length of pipe. For existing laterals identify problem areas, such as roots, cracks, fractures, broken pipe, and other unusual conditions found.
 - 2. Digital Photographs of the pipe condition, connections, points of interest and defects found. Indicate distance of defects to a point of reference such as face of building or mainline.

3. Inspection Log: Provide written report including:
 - a. Date and time of inspection.
 - b. Name Project, Contractor, and operator name.
 - c. Location, material and size of pipe.
 - d. Description of defects found, if any.

C. Certificates:

1. Submit manufacturer's certified statement that the pipe has been manufactured and tested in accordance with the applicable requirements of the California Plumbing Code, ASTM, & The Standard Specifications for Public Works Construction.

1.4 LICENSES, PERMITS & FEES

- A. The Contractor shall have a Class "C-34" or Engineering "A" Contractors license valid in the State of California.

1.5 DISPOSAL OF REMOVED MATERIALS INCLUDING ASBESTOS-CEMENT PIPE

- A. All removed materials, except those indicated on the plans or described herein to remain the property of the Owner, shall become the property of the Contractor and shall be disposed in accordance with local, state, and federal laws. Should any of those materials be considered as hazardous the Contractor shall provide the Owners Inspector with paper custody trail documentation of the disposal.
- B. Asbestos – Cement (A-C) Pipe Removal and Disposal: The plans for the project may indicate that existing asbestos-cement pipe is to be removed from the ground. Where so indicated the Contractor shall excavate with care, expose the pipeline and remove the A-C pipe to the nearest joint. Should the plans not call out the removal of the A-C pipe and A-C pipe is encountered, the Contractor shall obtain approval from the Inspector as to whether or not the A-C pipe is to be removed or can be left in place. Cutting of the pipe shall only be done if absolutely there is no other way to expose the length of pipe to the nearest joint that be separated and the Inspector approves the cutting of the pipe. Cutting of the pipe shall be done with a mechanical saw with a pressure water source to dampen the pipe and the dust from the cutting. To remove a coupling, the coupling may have to be broken in the trench. The pipe once removed from the trench may be broken for handling. The breaking shall be done within a plastic bagging or sheeting material to minimize the release of asbestos fibers into the atmosphere. Once removed and broken, if necessary, the A-C material shall be bagged and disposed of legally with the Inspector to be given a copy of all Contractor paperwork as to the legal disposal of the material. If the A-C pipe section(s) are removed intact the pipe can be removed by the Contractor from the project site and become the property and responsibility of the Contractor.

1.6 DRAWINGS

- A. Because of the small scale drawings, it is not possible to indicate all offsets, fittings and accessories which may be required. The Contractor shall carefully investigate the conditions surrounding installation of his work, furnishing the necessary piping, fittings, traps, and other devices which may be required to complete the installation.
- B. The general arrangement indicated on the drawings shall be followed as closely as possible. Coordinate with the Architectural, Structural, Mechanical and Electrical Drawings prior to installation of piping fixtures and equipment to verify adequate space available for installation of the work shown. In the event a field condition arises which makes it impossible to install the work as indicated, submit, in writing, the proposed departures to the Architect for his acceptance. Only when Architect's acceptance is given, in writing, shall Contractor proceed with installation of the work.
- C. In case of a difference in the specifications or drawings, or between the specifications and the drawings or in the drawings, the Contractor shall figure the most expensive alternate and after award of contract, shall secure direction from the Architect.

1.7 EXAMINATION OF PREMISES

- A. Before bidding on this work, Contractors shall make a careful examination of the premises and shall thoroughly familiarize themselves with the requirements of the contract. By the act of submitting a proposal for the work included in this contract, the Contractor shall be deemed to have made such study and examination, and that he is familiar with and accepts all conditions of the site.

1.8 PROTECTION

- A. All work, equipment and materials shall be protected at all times. Contractor shall make good all damage caused either directly or indirectly by his own workmen. Contractor shall also protect his own work from damage. He shall close all pipe openings with caps or plugs during installation. He shall protect all his equipment and materials against dirt, water, chemical and mechanical injury. Upon completion, all work shall be thoroughly cleaned and delivered in a new condition.
- B. Contractor shall be held responsible for all damage to equipment and materials until he has received written notice from the Architect or Engineer that his work has been accepted.

1.9 LOCATIONS

- A. The locations of apparatus, piping and equipment indicated on the drawings are approximate. Piping and equipment shall be installed in such a manner as to avoid all obstruction, preserve headroom, and keep openings and passages clear. The locations of and mounting heights of all fixtures shall be coordinated with the architectural plans and room elevations.
- B. Clearances and Openings: Contractor shall cooperate and coordinate his work with all other trades to avoid confliction and permit for a neat and orderly appearance of the entire installation. The Contractor shall, in advance of the work, furnish instructions to the General Contractor as to his requirements for equipment and material installation of any kind, whether or not specifically mentioned on drawings or in the specifications, and shall include recesses,

chases in walls, and all required openings in the structure. Should furnishing this information be neglected, delayed or incorrect and additional cuttings are found to be required, the cost of the same shall be charged to this Contractor.

1.10 SUBSTITUTIONS

- A. The Contractor assumes full responsibility that alternate manufacturers, items and procedures will meet the job requirements and is responsible for cost of redesign and of modifications to this and other parts of work caused by alternate items furnished under work in this Section. In view of these responsibilities, it is the purpose of these specifications to establish procedures which ensure that the Contractor has considered all the ramifications of proposed alternates before submitting them for review. Submittals which do not comply with the requirements of these specifications or which indicate proposed alternates were selected without proper regard to the requirements of the job, will not be approved. No more than one proposed alternate will be considered for each item.
- B. This Contractor is responsible to provide sufficient information to allow the Engineer to analyze any proposed alternate. If inadequate information is provided, the proposal will not be approved and resubmittal will not be allowed.
- C. The Architect or his authorized representative shall be the sole judge as to the quality and suitability of proposed alternate equipment, fixtures or materials and decisions of the Architect or that of his representative shall be final and conclusive.

1.11 RECORD DRAWINGS

- A. Contractor shall provide and keep up-to-date a complete "as-built" record set of redline prints which shall show every change from the original drawings and the exact "as-built" locations and sizes of the work provided under this Section of the specifications. This set shall include locations, dimensions, depth of buried piping, cleanouts, manholes, sewer invert locations, plugged wyes, tees, etc. On completion of the work, the Contractor shall incorporate all as-built information on a set of reproducible tracings provided by the Architect and this set of reproducible shall be delivered to the Architect.

1.12 QUALITY ASSURANCE

- A. Comply with the following as a minimum requirement:
 - 1. System Description: Grades and elevations are to be established with reference to the benchmarks referenced on the Plans.
 - 2. The work provided herein shall conform to and be in accordance with the Contract Plans, General Conditions/Specifications and Special Provisions, as well as the Standard Specifications for Public Works Construction ("Green Book"), 2018 Edition, adopted by the Southern California Chapter, American Public Works Association; herein referred to as the "Standard Specifications".
 - 3. California Plumbing Code, CPC, 2019 Edition, Chapter 7.
 - 4. California Administrative Code, Title 22, Section 64630(e)(2).

5. Underwriters Laboratories.
6. American Society of Testing Materials.

1.13 INSPECTION

- A. Notice shall be given to the Owner's Inspector at least 48 hours before starting construction.
- B. Contractor shall not allow or cause any of his work to be covered up before it has been duly inspected, tested and approved by the Owner, Architect or any other authorized inspectors having legal jurisdiction over his work. Should he fail to observe the above, he shall uncover the work and, after it has been inspected, tested and approved, recover it at his own expense.
- C. Inspection of the work shall not relieve the contractor of any obligations to complete the work as prescribed by the standard specifications. Any known defective work shall be corrected before testing or final inspection will be permitted. Unsuitable materials may be rejected even if these materials have been previously overlooked by the Inspector.
- D. The Owner shall have the authority to suspend the work completely or in part for such time as it may deem necessary if the contractor fails to carry out instructions given by the Owner, or to perform any required provisions of the plans and specifications. The contractor shall immediately comply with a written order of the Owner to suspend the work completely or in part. The work shall be resumed when improper methods or defective work are corrected as ordered and approved in writing by the Owner.

PART 2 - PRODUCTS

2.1 MATERIALS

- A. Pipeline:
 1. Project site sanitary sewer.
 - a. PVC (Poly Vinyl Chloride) Schedule 40 DWV Pipe, Conforming to ASTM D2665, ASTM F794, and ASTM F1866. Installer of PVC Schedule 40 DWV piping system shall carry ASTM D2855 and ASME B31.3 qualification. Installer shall provide proof of these qualifications to IOR prior to commencing work. Manufacturer: Charlotte pipe and foundry, Spears Manufacturing Company, Harvel Plastics Inc., or equal.
 - b. PVC primer and solvent for chemical weld of pipe and fittings shall be as recommended by pipe manufacturer. Containers for solvent and primer shall be clearly marked with manufacturer's data. Solvent and primer shall not be more than one year old. The safety placards must be visible. Blue or red hot glue shall not be used.
 - c. Primer: Weld-On P-70 by IPS, Conforming to ASTM F656.
 - d. Cement: Weld-On 711 (gray) by IPS, Conforming to ASTM D2564.

- B. Cleanout Assemblies: Cleanout plug shall be line size.
 - 1. See Construction Documents for details.
- C. Manhole Brick Mortar, Grout, and Plaster: Conform to Standard Specifications for Public Works Construction, Section 202 - Masonry Materials.
- D. Metal Covers, Frames and Accessories:
 - 1. Conform to Section 206 – Miscellaneous Metal Items of the Standard Specifications for Public Works Construction.
 - 2. Metal Covers and Frames: Vandal-resistant design.
 - 3. Hot-dip galvanize all steel parts after fabrication and prior to assembly in accordance with Section 210 – Paint and Protective Coating of the Standard Specifications for Public Works Construction.
- E. Bedding Materials: Conform to the requirements of Section 31 20 00 – Earthwork.

PART 3 - EXECUTION

3.1 PIPELINE INSTALLATION

- A. Install pipeline in a practical alignment and uniform slope to the point of connection as indicated on the plans. Prior to trench excavation, verify size, material, depth, and location of the point of connection. Notify Civil Engineer if point of connection elevation is different than that shown on construction drawings as it may affect the design of the system.
- B. No pipe shall be laid until the Geotechnical Project Manager inspects and approves the conditions of the bottom of the trench.
- C. Pipe laying shall proceed “up grade” with the spigot section of the bell-and-spigot pipe pointing in the direction of the flow.
- D. Each section of pipe shall be laid true to line and grade and in such a manner as to form an close concentric joint with the adjoining pipe and to prevent sudden offsets in the flow line.
- E. Where invert elevations are indicated, run pipe at a uniform slope between inverts shown.
- F. Join pipes and fittings as recommended by the manufacturer.
- G. All sewer lines & cleanouts shall be staked by a licensed surveyor if slope of grade is less than 2% and a complete set of cut sheets shall be supplied to the Inspector. All construction staking shall be installed and verified for grade and alignment prior to the start of construction.
- H. PVC schedule 40 DWV pipe and fittings shall be solvent welded. PVC pipe ends shall be cut ninety (90) degrees and Beveled from 10°-15° with a proper beveling tool, cleaned and cleared of cutting burrs prior to cementing. Use approved reaming tool. Pipe ends shall be wiped clean and free of dirt, moisture, oil, and other foreign material with a rag. Primer shall be

applied until the surface of the pipe and fitting is softened. Cement shall be applied with a light coat on the inside of the fitting and two heavier coats on the outside of the pipe. Pipe shall be inserted into the fitting and given a quarter turn while inserting if possible to help seat the cement while both the inside socket surface and outside surface of pipe are wet with solvent cement. Hold joint in place and undisturbed for 1 minute after assembly. Excess cement shall be wiped from the outside of the pipe.

- I. Pipe shall not be laid when the condition of the trench or the weather is unsuitable.
- J. The interior of the sewer pipe shall be kept clean of dirt and debris at all times. When work is not in progress, open ends of pipe and fittings shall be plugged.
- K. Where clearing after laying is difficult because of small pipe size, a suitable swab or squeegee shall be kept in the pipe and pulled forward past every joint immediately after joining has been completed.

3.2 CLEARANCES OF SANITARY PIPELINE

- A. Buildings or Structures - 2 feet.
- B. Parallel to Water Line:
 - 1. Building sanitary drain, (that which starts from the building perimeter to existing site sewer) shall not be laid in a common trench with the water line unless the bottom of the water line shall be at least 12 inch above the top of the sewer pipeline.
 - 2. In addition, the water pipe shall be placed on a solid shelf excavated on one side of the common trench with a minimum clear horizontal distance of 12 inch sewer or drain line.
 - 3. Site sanitary sewer (receiving more than one building sanitary drain or acid pipeline) shall be separated from the water line in accordance with the requirements of the State of California, Human and Welfare Agency, Department of Health Services.
- C. Crossing Water Line:
 - 1. Building sanitary drain shall be installed a minimum of 12 inches below the potable water line
 - 2. Site sanitary sewer shall be separated from the water main in accordance with the requirements of the State of California Administrative Code, Title 22, Section 64630(e)(2).

3.3 CLEANOUTS

- A. In general, provide cleanouts at the upper terminal for each sanitary pipeline, at intervals not exceeding 100 feet in straight run and any fraction thereof and for each aggregate horizontal change in direction exceeding 135 degrees. See construction drawings for locations.
- B. Install required cleanouts before horizontal pipelines are covered.
- C. In concrete-paved areas, extend cleanouts flush with finish grade.

- D. In unpaved and asphalt-paved areas, install cleanouts in yard boxes 4 inches below the yard box cover.
- E. In traffic areas, install countersunk cleanout plugs where raised heads protrude.

3.4 PIPE REMOVAL

- A. All existing underground sewer pipe and cleanouts, within the limits of new sewer pipe trenching shown on the plans, shall be removed from the site by the Contractor..
- B. Sewer lines which are to remain as abandoned, but have had pipe cut and removed, shall be capped.

3.5 SEWAGE BYPASS AND PUMPING PLAN

- A. The flow of sewage shall not be interrupted. Should the Contractor disrupt the operation of existing sanitary sewer facilities, or should disruption be necessary for performance of the work, the Contractor shall bypass the sewage flow around the work. Sewage shall be conveyed in closed conduits and disposed of in a sanitary sewer system. Sewage shall not be permitted to flow in trenches nor be covered by backfill.
- B. Whenever sewage bypass and pumping is required the Contractor shall submit a working drawing detailing his proposed plan of sewage bypass and pumping to the Owner.
- C. The plan shall indicate the locations and capacities of all pumps, sumps, suction and discharge lines. Equipment and piping shall be sized to handle the peak flow of the section of sewer line to be bypassed and pumped. Bypass piping, when crossing areas subject to traffic loads, shall be constructed in trenches with adequate cover and otherwise protected from damage due to traffic. Lay-flat hose or aluminum piping with an adequate casing and/or traffic plates may be allowed if so approved by the Engineer. Bypass pump suction and discharge lines that extend into manholes shall be rigid hose or hard pipe. Lay-flat hose will not be allowed to extend into manholes. The Contractor shall provide a backup bypass pumping system in case of malfunction. The backup bypass system shall provide 100 percent standby capability, and be in place and ready for immediate use. Each standby pump shall be a complete unit with its own suction and discharge piping. In addition to the backup system, the Contractor shall furnish and operate vacuum trucks when required to accomplish the work.
- D. Prior to the full operation of the bypass system, the Contractor shall demonstrate, to the satisfaction of the Engineer and Inspector, that both the primary and backup bypass systems are fully functional and adequate, and shall certify the same, in writing, to the Engineer in a manner acceptable to the Engineer.
- E. The Contractor shall provide one dedicated fuel tank for every single pump/generator, if fuel/generator driven pumps are used. The Contractor shall provide a fuel level indicator outside each fuel tank. The Contractor shall continuously (while in use) monitor the fuel level in the tanks and ensure that the fuel level does not drop below a level equivalent to two (2) hours of continuous bypass system operation. The Contractor shall take the necessary measures to ensure the fuel supply is protected against contamination. This includes, but is not limited to, fuel line water traps, fuel line filters, and protecting fuel stores from precipitation.

- F. The Contractor shall provide an emergency standby power generator, if electric power driven pumps are used.
- G. The Contractor shall continuously (while in use) monitor the operation of the bypass system and all impacted facilities. The Contractor shall submit, as part of their bypass plan, their monitoring procedure and frequency and shall maintain a log of the monitoring in a manner acceptable to the Engineer and Inspector.
- H. The Contractor shall continuously monitor the flow levels downstream and upstream of the bypass to detect any possible failure that may cause a sewage backup and/or spill, and shall include the means and methods of monitoring the flow in their Spill Response Plan.
- I. The Contractor shall routinely inspect and maintain the bypass system, including the backup system. The Contractor shall submit as part of their bypass plans their maintenance procedures and frequency and shall maintain a log of all pertinent inspection, maintenance and repair records in a manner acceptable to the Engineer and Inspector.
- J. All costs associated with sewer bypass requirements listed above shall be included in the Bid Item "Sewer Bypass System". If such Bid Item is not included in the Bid Form, include all costs associated with sewer bypass in the cost of other related bid items of work.

3.6 SPILL PREVENTION & EMERGENCY RESPONSE PLAN

- A. The Contractor shall prepare and submit a spill prevention and emergency response plan. The plan shall address implementation of measures to prevent sewage spills, procedures for spill control and containment, notifications, emergency response, cleanup, and spill and damage reporting.
- B. The Contractor shall be in full charge and be responsible for the Jobsite, the construction work of this contract, and subject to the directions of the Engineer or the Inspector. The Contractor shall observe and comply with all Federal, State, and local laws, ordinances, codes, orders, and regulations which in any manner affect the conduct of the work, specifically as it relates to sewage spills. The Contractor shall be fully responsible for preventing sewage spillage, containing any sewage spillage, recovery and legal disposal of any spilled sewage, any and all fines, penalties, claims and liability arising from negligently causing a sewage spillage and any violation of any law, ordinance, code, order, or regulation as a result of the spillage.
- C. The plan shall account for all storm drain systems and water courses within the vicinity of the work which could be affected by a sewage spill. Catch basins that could receive spilled sewage shall be identified. These catch basins shall be sealed prior to operating the bypass and pumping system. The Contractor shall remove all material used to seal the catch basins when the bypass and pumping system operations are complete.
- D. The Contractor shall be fully responsible for containing any sewage spillage, preventing any sewage from reaching a watercourse, recovery and legal disposal of any spilled sewage, any fines or penalties associated with the sewage spill imposed upon by the Agency and/or the Contractor by jurisdictional regulatory agencies, and any other expenses or liabilities related to the sewage spill.

- E. The Contractor shall exercise care not to damage existing public and campus improvements, interrupt existing services and/or facility operations that may cause a sewage spill. Any reasonably anticipated utility and/or improvement damaged by the Contractor shall be immediately repaired at the Contractor's expense. If construction operations damage an existing utility or damage or interrupt an existing service resulting in a sewage spill, the Contractor shall immediately notify the Owner. Before the start of construction, the Contractor shall request and obtain from the Owner an emergency roster of designated Owner representatives with their respective phone numbers, pager numbers, and cellular phone numbers. The Contractor shall take all measures necessary to prevent further damage or service interruption to an impacted utility or service. The Contractor is responsible for any resulting sewage spill(s).

3.7 PROTECTION

- A. Where new building sewers are to be connected into a sewer line which is in active use, the CONTRACTOR shall call for such protection as is necessary to prevent construction debris from being washed into the active sewers. Plugged inlets or other suitable protection shall be called for in the active manhole before beginning manhole modifications or tract sewer cleaning.

3.8 CLOSED-CIRCUIT TELEVISION INSPECTION

- A. Coordinate with owners inspector time and date of inspection. Project Inspector shall be present during the CCTV inspection.
- B. Clean laterals by hydraulic jet.
- C. Perform internal closed-circuit television inspection of lateral from the building to the campus mainline. Record sewer in its entirety with no breaks or interruptions. Move camera at a speed no greater than 30 feet per minute, stopping for a minimum of ten seconds to record pipe connections, defects, and points of interest.
- D. Maintain technical quality, sharp focus and distortion free picture. Pan, tilt, and rotate as necessary to best view and evaluate connections, defects and points of interest.
- E. Closed-circuit Television Equipment: As a minimum equipment shall include:
 - 1. Television camera specially designed for pipe inspections, and operative in 100 percent humidity conditions.
 - 2. Camera and television monitor capable of producing minimum 470H-line resolution color video picture.
 - 3. Camera capable to inspect laterals as small as three inches up to 70 feet from sewer mainline.
 - 4. Camera lighting shall be suitable to allow clear picture of inner wall at least ten feet in front.
- F. Defective Work:

1. New Laterals: Defective Work found shall be repaired at Contractor's expense. Perform a new closed-circuit television inspection at no cost to owner.
2. Existing Laterals:
 - a. If roots, sludge, or sediment material or other defect not related to the Work of this project impedes inspection, withdraw camera, restart inspection from opposite end and notify Owner of defects found.
3. If obstruction or stoppage was caused by Work related to this project, remove obstruction at no cost to Owner. Perform a new closed-circuit television inspection at Contractor's expense.

3.9 TESTING OF SEWER PIPE

- A. After installation of sewer pipe, testing shall be performed. The piping of the sewer system shall be tested with water or air except that plastic pipe shall not be tested with air. Contractor to follow guidelines set forth by the California Plumbing Code section 712.0 Testing.

3.10 CLEANUP

- A. Remove rubbish, debris, and waste materials and legally dispose of off the Project site.

WEIL

2-Inch Submersible Grinder Pump

2436C



Heavy duty pump for commercial and industrial applications.
Solids are reduced to a 3/8 inch diameter or less.

Pump Type **Grinder**
Disch. Size **2 Inch**
Disch. Type **ANSI**
Mounting Style **2613 Removal**

Pump

- Case - Cast Iron
- Impeller - Cast Iron
- Rotating Cutter - 440C Stainless Steel
Rockwell 58C
- Shredder Ring - 440C Stainless Steel
Rockwell 58C
- Stainless Steel Hardware

Options

- Bronze Impeller
- 316 Stainless Steel Impeller
- 575 Volt 3 Phase 60hz Motor
- Additional Power Cable Lengths
- High Temperature Motor
- Stainless Steel Lifting Cable

Motor

Single Seal

- Carbon against Ceramic

Air-Filled Hermetically Sealed

Shaft - Stainless Steel Series 300

Motor Shell - Cast Iron

Insulation - Class F

Ball Bearings - 2 - Double Sealed

Power Cable Length - 20 ft

Three-phase motor

- 1750 RPM
- 60 Hz, 208-230 or 460 volts

Single-phase capacitor start motor

- 1750 RPM
- 60 Hz, 115 or 208-230 volts
- Automatic reset thermal and overload protection

Flow - To prevent solids from settling out	
Discharge Pipe Size Dia Inches	Minimum Flow GPM
1 1/2	15
2	25
3	50

Capacities - Wet Wells		
Dia or Side Inches	Gallons per Foot of Depth	
	Round	Square
18	13	17
24	24	30
30	37	47
36	53	67
48	94	120
60	147	187
72	212	269

Good wet well design
Maximum 10 starts per hour.
Minimum run time - 1 1/2 minutes.

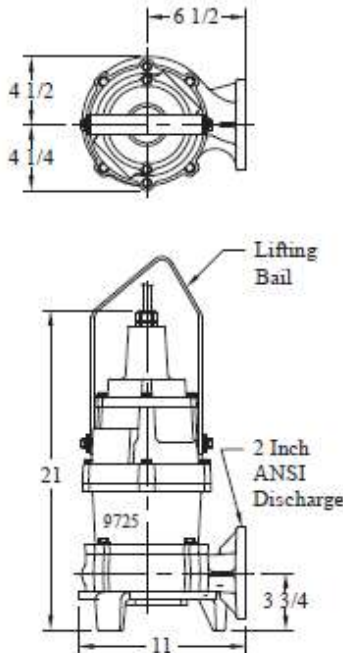

Impeller curves are Non-Overloading at any point on curve.
These are standard impeller trims. Other trims are available as options.

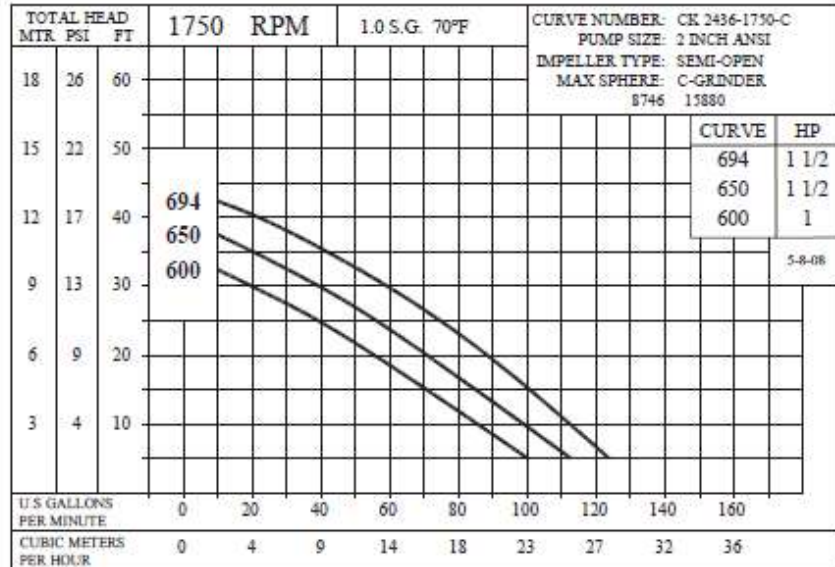

SN-2436CA-3



Replaces SN-2436C, July 1, 2015

SN-2436C

DECEMBER 13, 2018

2436C

Item number	: Default	Size	: Weil 2-2436C-1750
Service	:	Stages	: 1
Quantity	: 1	Based on curve number	: CK-2436C-1750 Rev 0.0
Quote number	: 884007	Article Number	:
		Date last saved	: 16 Feb 2021 6:18 PM

Operating Conditions		Liquid	
Flow, rated	: 50.00 USgpm	Liquid type	: Water
Differential head / pressure, rated (requested)	: 23.00 ft	Additional liquid description	:
Differential head / pressure, rated (actual)	: 23.04 ft	Solids Diameter, required / pump max	: 0.00 in / 2.00 in
Suction pressure, rated / max	: 0.00 / 0.00 psi.g	Solids concentration, by volume	: 0.00 %
NPSH available, rated	: Ample	Temperature, max	: 68.00 deg F
Site Supply Frequency	: 60 Hz	Fluid density, rated / max	: 1.000 / 1.000 SG
Performance		Viscosity, rated	: 1.00 cP
Speed criteria	: Synchronous	Vapor pressure, rated	: 0.34 psi.a
Speed, rated	: 1750 rpm	Material	
Impeller diameter, rated	: 6.25 in	Material selected	: Standard
Impeller diameter, maximum	: 6.94 in	Pressure Data	
Impeller diameter, minimum	: 6.00 in	Maximum working pressure	: 15.05 psi.g
Efficiency	: 28.00 %	Maximum allowable working pressure	: N/A
NPSH required / margin required	: - / 0.00 ft	Maximum allowable suction pressure	: N/A
Ns (imp. eye flow) / Nss (imp. eye flow)	: 1,323 / - US Units	Hydrostatic test pressure	: N/A
MCSF	: 10.00 USgpm	Driver & Power Data (@Max density)	
Head, maximum, rated diameter	: 34.77 ft	Driver sizing specification	: Rated power
Head rise to shutoff	: 50.91 %	Margin over specification	: 0.00 %
Flow, best eff. point	: 59.43 USgpm	Service factor	: 1.00
Flow ratio, rated / BEP	: 84.14 %	Power, hydraulic	: 0.29 hp
Diameter ratio (rated / max)	: 90.06 %	Power, rated	: 1.04 hp
Head ratio (rated dia / max dia)	: 70.59 %	Power, maximum, rated diameter	: 1.05 hp
Cq/Ch/Ce/Cn [ANSI/HI 9.8.7-2010]	: 1.00 / 1.00 / 1.00 / 1.00	Minimum recommended motor rating	: 1.50 hp / 1.12 kW
Selection status	: Acceptable		

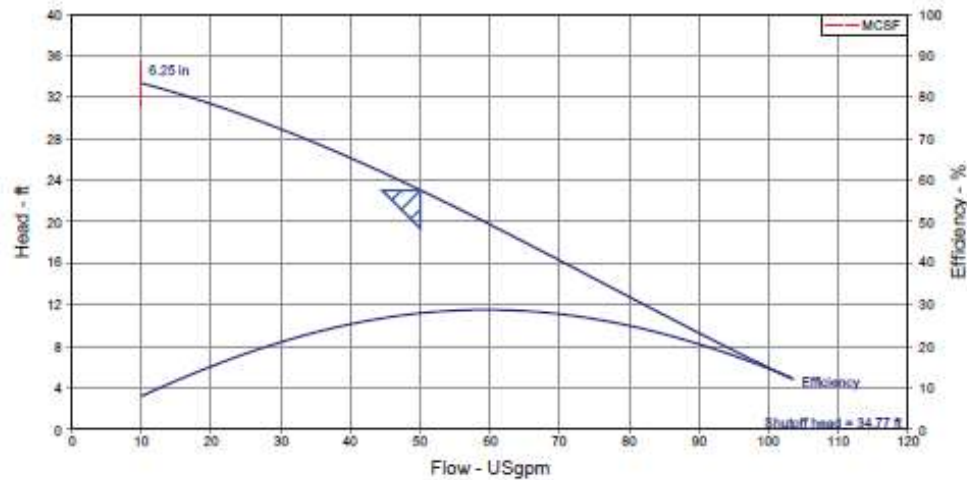
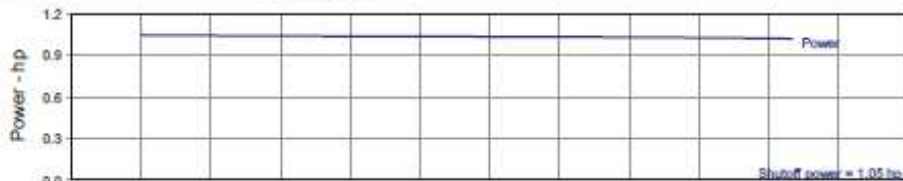

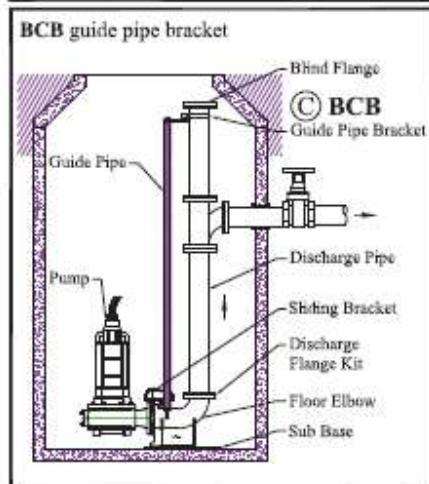
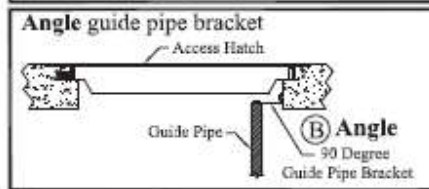
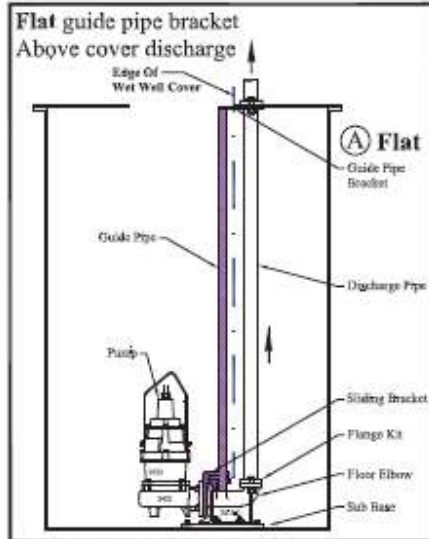

Discharge Flange Kit - For Floor Elbow

Includes - Flange, Gasket and Hardware
Weil = 2 bolt oval configuration

Order Number	Material	Pipe Type	Flange Type
2613K102	Cast Iron	Threaded	Weil
2613K202	Cast Iron	Plain End	Weil
2613K942	316 SS	Plain End	Weil

Intermediate Guide Pipe Bracket:

205.666.002	Intermediate Guide Pipe Bracket
-------------	---------------------------------

System Includes:

- Discharge Floor Elbow - one
- Sliding Bracket - one
 - Iron or
 - Bronze for use with Explosion Proof Motors
 - 316 Stainless Steel
- Guide Pipe Bracket - one
 - (A) Flat (cover mount) - bolts to wet well cover or
 - (B) Angle 90° (side mount) bolts to vertical side wall or
 - (C) BCB Bracket - mounts to discharge pipe

Not Included:

- Discharge Pipe - (2 inch schedule 40), Guide Pipe - (1 inch schedule 40)

Options:

- Discharge Flange Kit for Floor Elbow
- Intermediate Guide Pipe Bracket
- Sub Base for Floor Elbow
- Level Control Lifting Assembly for BCB Duplex Bracket

Removal System:

Simplex					
Order Number	Floor Elbow	Sliding Bracket	Guide Pipe Bracket	Mount Type	Weight Lbs.
2613K1021	Iron	Iron	Flat	Cover	42
2613K2021	Iron	Bronze	Flat	Cover	42
2613K9102	316 SS	316 SS	Flat	Cover	42
2613K5013	Iron	Iron	Angle	Side	42
2613K6032	Iron	Bronze	Angle	Side	42
2613K9122	316 SS	316 SS	Angle	Side	42
2613K3021	Iron	Iron	BCB	Pipe	42
2613K4021	Iron	Bronze	BCB	Pipe	42
2613K9132	316 SS	316 SS	BCB	Pipe	42
Duplex - BCB System					
Order Number	Floor Elbow	Sliding Bracket	Guide Pipe Bracket	Mount Type	Weight Lbs.
2613K7021	Iron	Iron	Pipe	BCB	84
2613K7031	Iron	Bronze	Pipe	BCB	84
2613K9722	316 SS	316 SS	Pipe	BCB	84

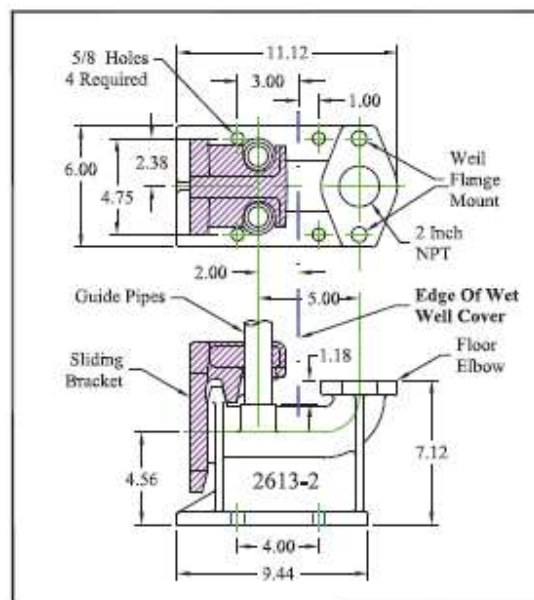

Float Switch

The 8230 level controls utilize pole mounted tethered switches. The pole may be suspended from either a wet well cover or a bracket fastened to the wall of the wet well.

Each tethered switch includes a cord grip and strap mount for mounting to a 3/4 inch or 1 inch pole.

The 8230 tethered switch is normally open, closing on liquid rise. Use with Weil 8100 Control Panels. The switch is not rated for motor loads.

- Single-pole switch has 16/2 cord with 2 wires, black/white.
- 115 volt, 3 amp pilot duty.

Duplex System

Lead pump starts when the liquid level activates Switch FS2. The lead pump will run until the liquid level deactivates Switch FS1.

The Lag pump will start if the liquid level activates Switch FS3. Both pumps continue to run until the liquid level deactivates Switch FS1.

If the liquid level activates Switch FSA the high water alarm circuit will turn on.

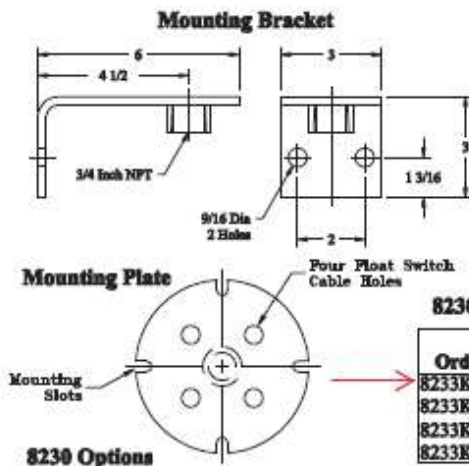

Configuration	Switches Required
Simplex	2
Simplex with Alarm	3
Duplex	3
Duplex with Alarm	4

8230 Tethered Float Switch

Order Number	Type of Assembly	Cord Length (Ft.)	Approx. Wt. (Lbs.)
8233K1006	Switch only with cord grip	20	4
8233K1014	Switch only with cord grip	40	6
8233K1016	Switch only with cord grip	60	8
8233K1018	Switch only with cord grip	80	10

Option	Description
314.399.000	Mounting Bracket - For sidewall, suspends 3/4 inch pipe from wet well wall. Pipe Not included.
315.445.001	Mounting Plate - Round 8-inch diameter with four holes for level control cable cord grips. Suspends 3/4 or 1 inch pipe from mounting plate. Pipe not included. Fastens to wet well cover with fasteners.
304.331.096	Mounting Pipe - 3/4 inch schedule 40, 10 feet long. Threaded on one end.
303.935.103	Mounting Pipe - 1 inch schedule 40, 10 feet long. Threaded on one end.

Simplex Configuration

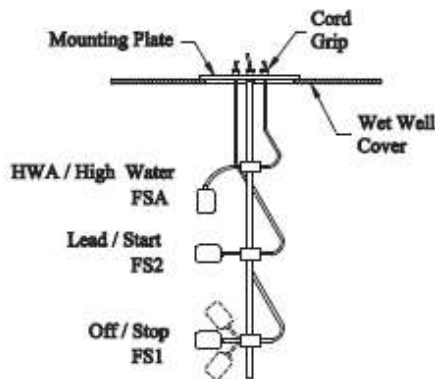

Duplex Configuration

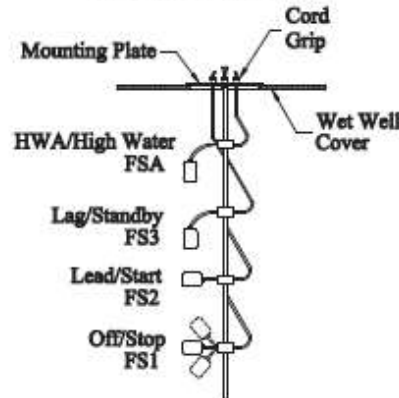

How to order: Specify Order Number, Wet Well Depth and Options.
F. O. B. Cedarburg (Milwaukee), Wisconsin

R

Replaces SN-8230. March 1, 2009

D-35

SN-8230

JUNE 1, 2014

8230



MECHANICAL FLOAT SWITCH INSTALLATION INSTRUCTIONS DUPLEX - 4 FLOAT SWITCHES

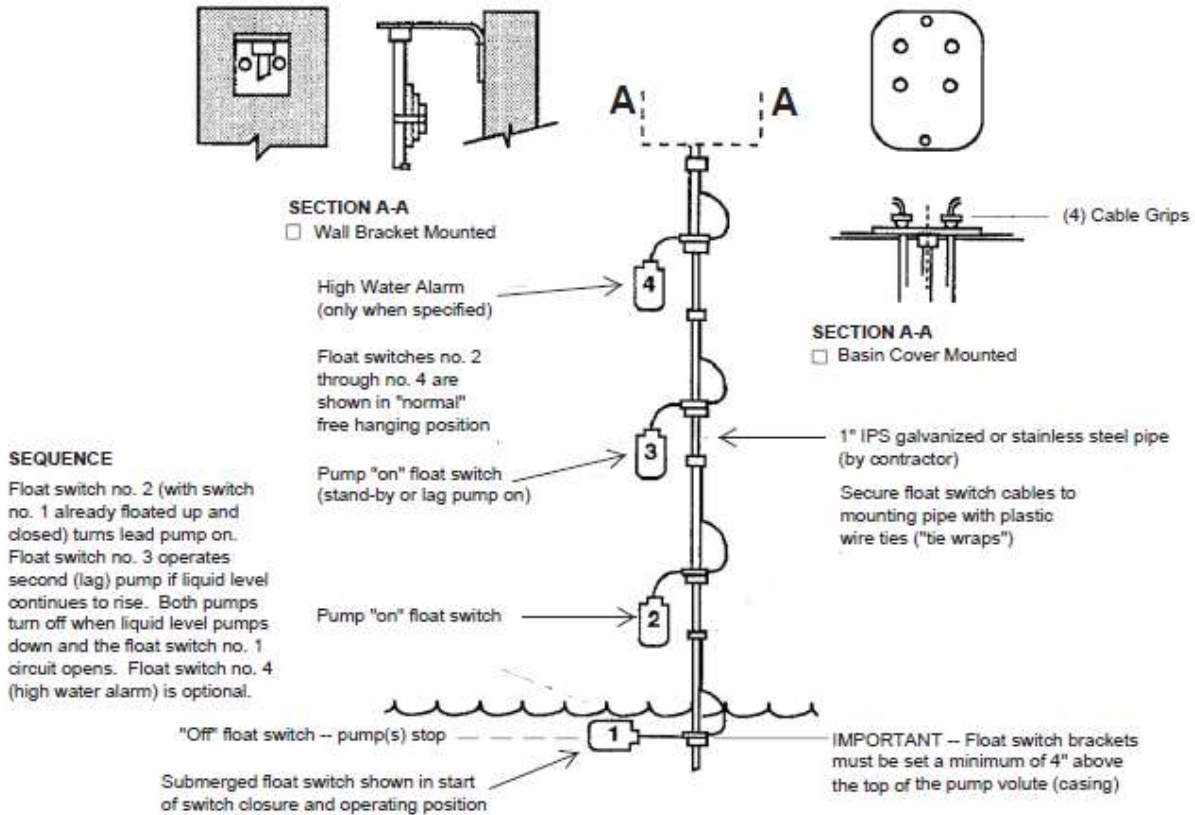

SEQUENCE

Float switch no. 2 (with switch no. 1 already floated up and closed) turns lead pump on. Float switch no. 3 operates second (lag) pump if liquid level continues to rise. Both pumps turn off when liquid level pumps down and the float switch no. 1 circuit opens. Float switch no. 4 (high water alarm) is optional.

In determining the correct spacing of the float switches, please follow these steps:

- 1) Set float switch no. 4 "high water alarm level" at least 2" below the lowest inlet.
- 2) Float switch no. 3 "standby" should be set directly below float switch no. 4, with the float switches at least 90 degrees apart to prevent the lower no. 3 switch from hitting or entangling with the upper no. 4 switch as it rises with the liquid.
- 3) Float switch no. 2 "pump on" should be set 3"- 4" below switch no. 3.
- 4) Float switch no. 1 "pumps stop" ("off") must be set a minimum of 4" above the top of the pump volute (casing).
- 5) Check complete installation to see that none of the float switches hit the basin wall, the pumps, piping, or valves. This check should be made with the float switches in both "on" and "off" positions.

NOTE: Float switches are not to be installed evenly spaced as shown. Spacing between float switch no. 1 and no. 2 determines the pump run time. This should be at least 2 minutes.

- 1) If floats are close enough to touch, then the floats should be offset from each other to prevent any possible obstruction/entanglement.
- 2) ALL CABLES SHOULD BE SECURED NEATLY TO THE FLOAT POLE TO PREVENT ANY OBSTRUCTION.
- 3) Do not run float cables through the upper float bracket hole.

QUESTIONS? Call 1-800-74-PUMPS

WEIL Duplex Alternating Pump Control Panel

Type 4 Double Door Dead Front Enclosure

8167
Duplex

- The 8167 Duplex Panel controls two pumps. It is a deluxe full featured panel that includes a high water alarm system, alternator, and a lockable through-the-door disconnect on inner door.
- Type 4 enclosure for indoor or outdoor use. Provides a degree of protection against falling rain, splashing water, and hose-directed water; undamaged by the formation of ice on the enclosure.
- Exceeds Type 1, 3R and 12 requirements.
- Panel can be operated on 50 or 60 Hertz power.
- Select level controls
 - 8213 Lever
 - 8220 Pressure Diaphragm
 - 8230 Tethered
- Requires one 8213 lever or four 8220 or 8230 level switches - three switches for level control and one switch for the high water alarm.

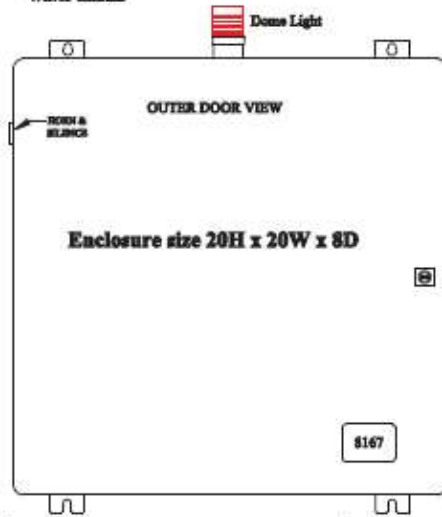

- Control Panel Selection Guide**
- Determine Phase and Voltage
 - Determine maximum run current in amps required by the pump motor.

Panel Includes

- U/L Listed Label
- LED Lights, hour meter, switches, and test buttons are mounted on inner door.
- One lockable panel disconnect; through-the-door with door interlock on inner door. The mechanical interlock prevents the door from being opened when the disconnect is in the ON position. Lock is not provided.
- Padlocking hasp - on outer door, padlock not included.
- Two lockable pump disconnects, on motor overload protector. Lock is not provided.
- Electric Alternator has a 3 position selector switch; that locks the pumps in Auto, Pump 1-2 or Pump 2-1 sequencing.
- Two contactors-Industrial duty.
- Two Overloads - one per pump. Ambient compensated bi-metallic (Class 10) motor overload circuit protector. Instantaneous magnetic for short circuit protection. Single-phase protection for three-phase motors. Field adjustable within the amp range.
- Control transformer with fused primary and secondary on all three-phase and single-phase 208 and 230-volt. Single-phase 115-volt has a fused control circuit.
- Pump run switches - one per pump. Three position TOA (test-off-automatic) with spring return to off from test.
- Green lights (2) indicates power to pump motors.
- White light indicates control power on.
- Red overload lights (2) indicates motor overload condition and pump is off. Light remains on and pump remains off until reset.
- Hour meters (2). Non resetting meter indicates total pump run time.
- General alarm fault and pump run status isolated contacts.
- High Water Alarm System Type 4x. Hold finger over hole of horn for 1-2 seconds and remove to silence horn (95 dB).
 - Red HWA light and alarm test button on inner door.
 - Two isolated contacts for remote monitoring and/or to use as a connection to a phone dialer.
- Alarm LED Dome Light - Lexan, red flashing on top of enclosure. Light indicates a general fault condition; overload & high water. Light remains on until condition is corrected.
- Control Terminal board, numbered and wired.
- Layout and schematic CAD diagrams are provided. Installer connections at terminal board are clearly marked.

Motor Protector Amp Range	Order Number			Approx. Weight Lbs.
	Single-Phase 115 Volts	Single-phase 208 or 230 Volts	Three-Phase 208, 230,460 Volts	
1.0 - 1.6	8167-L-016	8167-D-016	8167-T-016	73
1.6 - 2.5	8167-L-025	8167-D-025	8167-T-025	73
2.5 - 4.0	8167-L-040	8167-D-040	8167-T-040	73
4.0 - 6.3	8167-L-063	8167-D-063	8167-T-063	73
6.3 - 10.0	8167-L-100	8167-D-100	8167-T-100	73
10.0 - 16.0	8167-L-160	8167-D-160	8167-T-160	73
16.0 - 20.0	8167-L-200	8167-D-200	8167-T-200	75
20.0 - 25.0	8167-L-250	8167-D-250	8167-T-250	75
*25.0 - 32.0	8167-L-320	8167-D-32.0	8167-T-32.0	88
*32.0 - 40.0	8167-L-40.0	8167-D-40.0	8167-T-40.0	88
*40.0 - 50.0	8167-L-50.0	8167-D-50.0	8167-T-50.0	98

*Includes 2nd disconnect and larger enclosure

How to Order: Specify the Order Number, System Phase and Voltage, and Pump Motor HP.
F.O.B. Cedarburg (Milwaukee), Wisconsin

SN-8167-21-2

R

Replaces SN-8167, June 1, 2014

D-35

SN-8167

MARCH 1, 2017

8167

WEIL Duplex Alternating Pump Control Panel

8167
Duplex

Type 4 Double Door Dead Front Enclosure

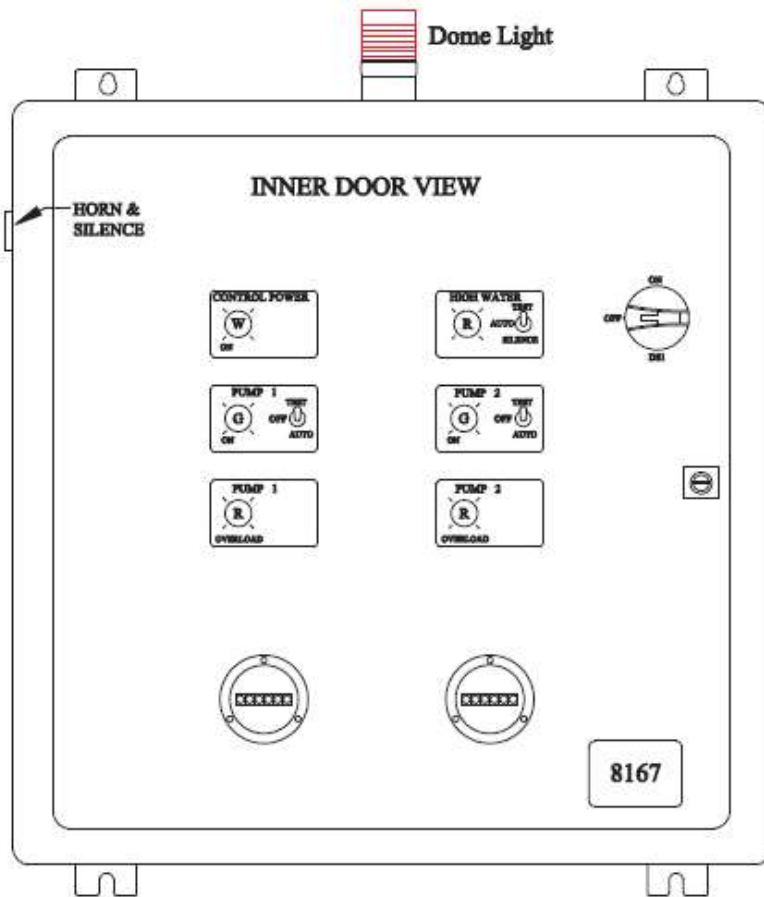

Use any of the three level controls with duplex control panel.

8213 Lever

8220 Pressure Diaphragm

8230 Tethered

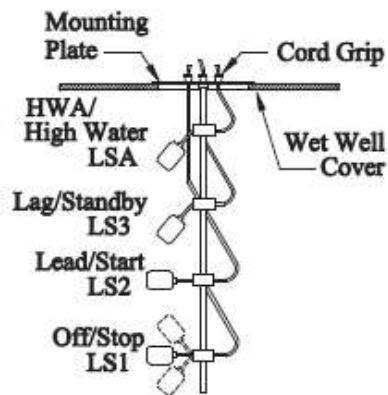
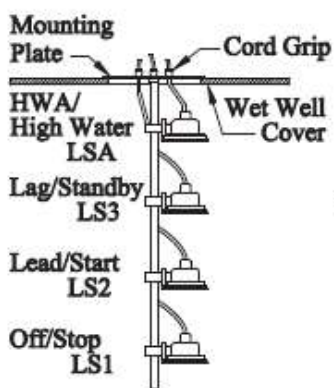
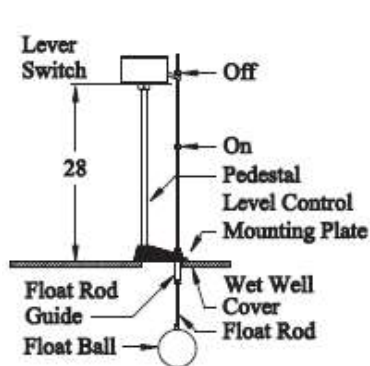

8167

MARCH 1, 2017

SN-8167-3

SN-8167-3

Gastight Sealing of Weil Aquatronics Basin Covers

Basin covers supplied by Weil Aquatronics are provided with rope-type caulking material. This material, properly installed, will provide a gastight seal between covers and frames, between access doors and covers, and any other flat mating surfaces on the cover.

We supply M-D Building Materials rope-type caulking material, part number 71522 (gray –30' linearfeet); however, any waterproof rope-type caulking material would be sufficient.

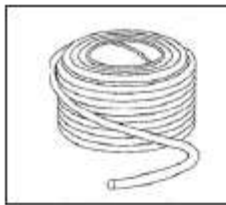

REPLACEABLE CORD WEATHERSTRIP

This weatherstrip cord is easily installed by pressing into the gap to be filled. This product can be used both inside and outside. Can be cut to length to fit your application. Available in 30' and 90' rolls.

<u>Item No.</u>	<u>Width</u>	<u>Height</u>	<u>Length</u>	<u>Finish</u>
71522	n/a	n/a	360"	Gray

Installation & Maintenance:

1. Clean surfaces to be sealed.
2. Apply caulking material as required. Normally one bead of material is sufficient to provide a gastight seal, however large or irregular surfaces may require more than one bead of material to provide a proper seal.
3. Mating surfaces that are unsealed (access doors, inspection plates, etc.) should have the existing material removed. Then clean the sealing surfaces and apply new sealing material.



weil aquatronics

Engineered Pumps
and Hydronic Equipment

1-800-74-PUMPS (747-8677)
562-364-7430 Fax: 818-247-0083
E-Mail: info@weilaquatronics.com

FIBERGLASS SUMP BASINS INSTALLATION INSTRUCTIONS

1. **Excavation Dimensions:** Excavation shall be 6" deeper than the depth of the basin, below finish grade and done in such a manner as to preserve the undisturbed state of bearing soils at the bottom. Diameter of excavation shall be sufficient to allow for necessary external pipe connections with a minimum 12" greater than the basin diameter.
2. **Backfill Materials:**
 - a. The backfill materials shall be inert, free flowing granular soil such as clean sand or gravel (1/4" mesh or finer).
 - b. Acceptable backfill includes "stone dust" from rock crushing operation provided it possesses all the characteristics of free flowing sand and contains less than 20% by weight passing the No. 200 mesh sieve. Soil fines must be non-plastic.
 - c. Silts, clays, organic soil, granulated cinder, slag and similar corrosive material shall not be used. Backfill shall be free of organic material, loam, trash, snow, ice, stones, rubble, etc.
 - d. A free flowing material is essential for preparation of the support bed and for backfilling in order to provide complete and proper support for the bottom and sides of the basin.
3. **Pipe Connections:** Make necessary pipe connection in approved manner. Connection may be threaded, caulked joints, no-hub or other specified approved method.
4. **Backfill as follows:**
 - a. If the hole is flooded, the water level shall be pumped down to maximum depth of 3 inches before preparing the bed and placing the basin. Water level shall be maintained below bottom of the basin until the excavation is backfilled and until there is adequate safety against uplift.
 - b. The first layer of backfill is the base for the basin and shall be at least 6" thick.
 - c. Place the basin on the bed and after aligning and leveling, push additional fill under and around the basin and compact by tamping to a uniform depth of 12" around the basin. This insures that the established grade and level of the basin will be maintained during remainder of the backfilling operation.
 - d. Backfill shall be continued in one foot layers with specified backfill uniformly distributed and compacted around the basin.
 - e. Concrete encasement in lieu of backfill is **NOT** recommended.
5. **Cover:** The cover shall be bolted in place with an approved gasket material to effect a gas tight seal. Basins installed in traffic areas must have separate curb frames imbedded in finish floor and not in contact with any portion of the basin.

NOTE: In accordance with City of Los Angeles General Approval:
"Sump pumps shall not rest on the bottom of the sump unless the bottom is supported on a suitable level concrete base."

© 1980 Weil Aquatronics, Inc.
C:\WPWin\IDSM Material\Fiberglass Basins.doc

BACKFILLING

BACKFILL MATERIAL. Backfill material should be clean, well-granulated, free-flowing, noncorrosive, and inert. It should be free of ice, snow, debris, rock, or organic material, all of which could damage the tank and interfere with the compaction of the backfill material. The largest particles should not be larger than 3/4 inch. Not more than 3 percent (by weight) should pass through a #8 sieve, and the backfill material should conform to ASTM C-33, Paragraph 9.1 requirements. Approved backfill materials include:

- Pea Gravel, naturally-rounded particles with a minimum diameter of 1/8 inch and a maximum diameter of 3/4 inch.
- Crushed Rock, washed and free-flowing angular particles between 1/8 inch and 1/2 inch in size.

PLACEMENT AND COMPACTION OF BACKFILL. compaction of backfill materials should be adequate to ensure the support of the tank, and to prevent movement or settlement. Backfill materials should be place in 12 inch lifts and compacted to a minimum soil modulus of 700 pounds per square inch (psi).

SUPPORTING PIPING, EQUIPMENT AND ACCESSORIES. Support for piping, equipment and other accessories must be provided during backfilling. Using the basin to support piping, equipment, cribbing, bracing or blocking is never permitted. During backfilling, temporary supporting materials must be carefully installed and removed to prevent damage to the basin, piping or equipment.

WARNING! Using the basin to support any loading carried or created by piping, equipment, cribbing, bracing or blocking is never permitted.

ANCHORAGE

GENERAL. When basin installations are located in areas subject to high water tables or flooding, provisions should be made to prevent the basins, either empty or filled, from floating. The buoyancy force to be offset is determined primarily by the volume of the basin. The principle offsetting factors include:

- Backfill materials.
- Concrete hold-down pad.
- Friction between the tank, backfill materials and the surrounding soil.

METHODS OF ANCHORAGE. All methods of anchoring basins use the weight of the backfill materials to offset the buoyancy forces. The use of supplemental mechanical anchoring methods (a concrete hold-down pad) increases the amount of backfill ballast which is mechanically attached to the basin. The recommended method of attachment is to pour concrete grout over the basin's anti-floatation flange and concrete hold-down pad (see attached illustration).

ANCHORAGE REQUIREMENTS. Requirements for anchorage, thickness of concrete hold-down pads, as well as the size of anchors and reinforcement must be calculated for each installation based on the environmental conditions of that specific installation.

WARNING! Use "submerged" material weights when calculating anchorage requirements. Example: weight of concrete (150 pounds per cubic foot) minus the weight of the water 62.4 pounds per cubic foot) equals a "submerged" weight of 87.6 pounds per cubic foot.

FIBERGLASS BASIN INSTALLATION REFERENCE GUIDE

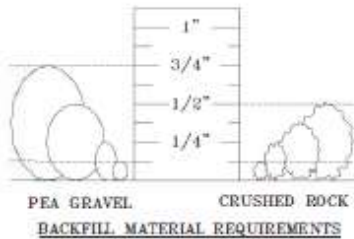
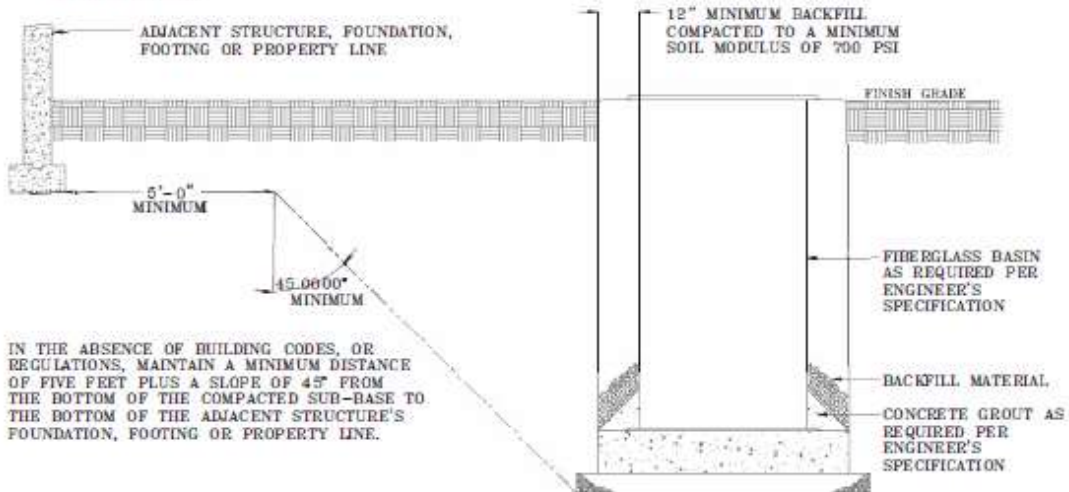
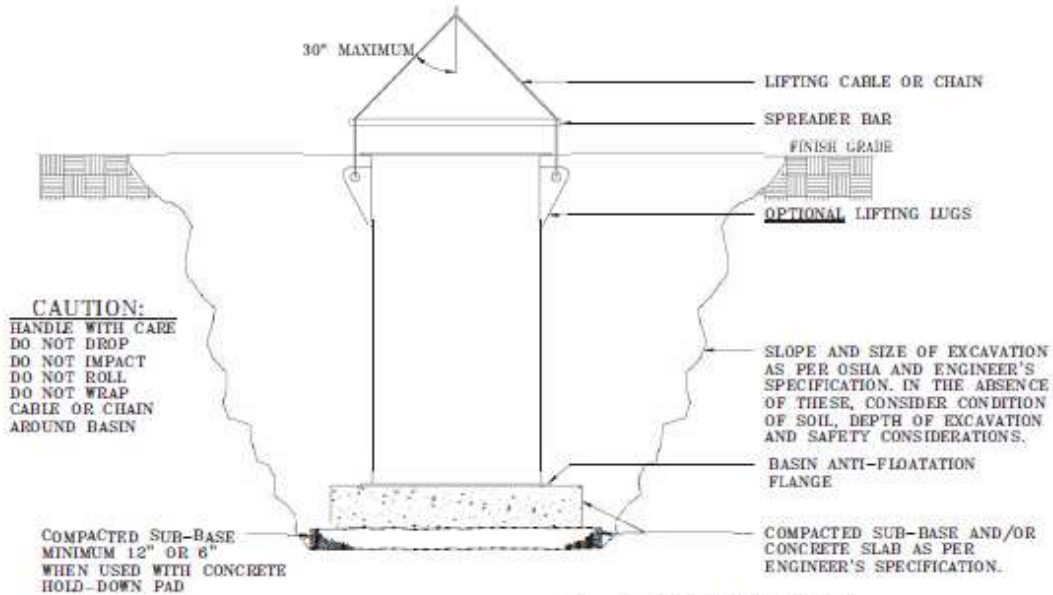

NOTE:
The intent of these installation instructions and illustrations is to ensure that damage or premature failure to the basin will not occur. These installation instructions and illustrations are NOT intended to preclude normal safety procedures which should be followed to prevent injury to personnel. SAFE INSTALLATION PROCEDURES SHALL BE ENTIRELY THE RESPONSIBILITY OF THE INSTALLER.

7-130
10026 REV.1 05/06/02

END OF SECTION