

 CollegeBoard

AP<sup>®</sup>

**INCLUDES**

- ✓ Course framework
- ✓ Instructional section
- ✓ Sample exam questions

# AP<sup>®</sup> Physics C: Electricity and Magnetism

---

**COURSE AND EXAM DESCRIPTION**

Effective  
Fall 2019

# AP<sup>®</sup> Physics C: Electricity and Magnetism

---

## COURSE AND EXAM DESCRIPTION

Effective  
**Fall 2019**

**AP COURSE AND EXAM DESCRIPTIONS ARE UPDATED PERIODICALLY**

Please visit AP Central ([apcentral.collegeboard.org](https://apcentral.collegeboard.org)) to determine whether a more recent course and exam description is available.

## About College Board

College Board is a mission-driven, not-for-profit organization that connects students to college success and opportunity. Founded in 1900, College Board was created to expand access to higher education. Today, the membership association is made up of over 6,000 of the world's leading educational institutions and is dedicated to promoting excellence and equity in education. Each year, College Board helps more than seven million students prepare for a successful transition to college through programs and services in college readiness and college success—including the SAT® and the Advanced Placement® Program (AP®). The organization also serves the education community through research and advocacy on behalf of students, educators, and schools.

For further information, visit [collegeboard.org](https://collegeboard.org).

## AP Equity and Access Policy

College Board strongly encourages educators to make equitable access a guiding principle for their AP programs by giving all willing and academically prepared students the opportunity to participate in AP. We encourage the elimination of barriers that restrict access to AP for students from ethnic, racial, and socioeconomic groups that have been traditionally underrepresented. Schools should make every effort to ensure their AP classes reflect the diversity of their student population. College Board also believes that all students should have access to academically challenging course work before they enroll in AP classes, which can prepare them for AP success. It is only through a commitment to equitable preparation and access that true equity and excellence can be achieved.

# Contents

---

- v **Acknowledgments**
- 1 **About AP**
- 4 **AP Resources and Supports**
- 6 **Instructional Model**
- 7 **About the AP Physics C: Electricity and Magnetism Course**
- 7 College Course Equivalent
- 7 Prerequisites
- 8 Lab Requirement

---

## **COURSE FRAMEWORK**

- 11 **Introduction**
- 12 **Course Framework Components**
- 13 Science Practices
- 15 Course Content
- 18 **Course at a Glance**
- 21 **Unit Guides**
- 22 Using the Unit Guides
- 25 **UNIT 1:** Electrostatics
- 43 **UNIT 2:** Conductors, Capacitors, Dielectrics
- 57 **UNIT 3:** Electric Circuits
- 73 **UNIT 4:** Magnetic Fields
- 89 **UNIT 5:** Electromagnetism

---

## **LABORATORY INVESTIGATIONS**

- 103 **Lab Experiments**
- 104 **How to Set Up a Lab Program**

---

## **INSTRUCTIONAL APPROACHES**

- 109 **Selecting and Using Course Materials**
- 109 **Guided Inquiry in AP Physics C: Electricity and Magnetism**
- 110 **Instructional Strategies**
- 119 **Developing the Science Practices**

---

## **EXAM INFORMATION**

- 137 **Exam Overview**
- 142 **Sample Exam Questions**

---

## **APPENDIX**

- 159 **Table of Information: Equations**

THIS PAGE IS INTENTIONALLY LEFT BLANK.

# Acknowledgments

---

College Board would like to acknowledge the following committee members, consultants, and reviewers for their assistance with and commitment to the development of this course. All individuals and their affiliations were current at the time of contribution.

**Connie Wells**, *Rockhurst University, Kansas City, MO*

**Peggy Bertrand**, *University of Tennessee, Knoxville, TN (Retired)*

**Michelle Strand**, *West Fargo High School, West Fargo, ND*

**James Vanderweide**, *Hudsonville High School, Hudsonville, MI*

## College Board Staff

**Ryan Feuer**, *Developmental Editor, AP Curricular Publications*

**Amy Johnson**, *Director, AP Instructional Design and PD Resource Development*

**Trinna Johnson**, *Director, AP Curriculum and Content Development*

**David Jones**, *Director, AP Curriculum and Content Development*

**Claire Lorenz**, *Senior Director, AP Instructional Design and PD Resource Development*

**Daniel McDonough**, *Senior Director, AP Content Integration*

**Allison Milverton**, *Director, AP Curricular Publications*

**Tanya Sharpe**, *Senior Director, AP Curriculum and Content Development*

**SPECIAL THANKS** *John R. Williamson*

THIS PAGE IS INTENTIONALLY LEFT BLANK.

# About AP

---

College Board’s Advanced Placement® Program (AP®) enables willing and academically prepared students to pursue college-level studies—with the opportunity to earn college credit, advanced placement, or both—while still in high school. Through AP courses in 38 subjects, each culminating in a challenging exam, students learn to think critically, construct solid arguments, and see many sides of an issue—skills that prepare them for college and beyond. Taking AP courses demonstrates to college admission officers that students have sought the most challenging curriculum available to them, and research indicates that students who score a 3 or higher on an AP Exam typically experience greater academic success in college and are more likely to earn a college degree than non-AP students. Each AP teacher’s syllabus is evaluated and approved by faculty from some of the nation’s leading colleges and universities, and AP Exams are developed and scored by college faculty and experienced AP teachers. Most four-year colleges and universities in the United States grant credit, advanced placement, or both on the basis of successful AP Exam scores; more than 3,300 institutions worldwide annually receive AP scores.

## AP Course Development

In an ongoing effort to maintain alignment with best practices in college-level learning, AP courses and exams emphasize challenging, research-based curricula aligned with higher education expectations.

Individual teachers are responsible for designing their own curriculum for AP courses, selecting appropriate college-level readings, assignments, and resources. This course and exam description presents the content and skills that are the focus of the corresponding college course and that appear on the AP Exam. It also organizes the content and skills into a series of units that represent a sequence found in widely adopted college textbooks and that many AP teachers have told us they follow in order to focus their instruction. The intention of this publication is to respect teachers’ time and expertise by providing a roadmap that they can modify and adapt to their local priorities and preferences. Moreover, by organizing the AP course content and skills into units, the AP Program is able to provide teachers and students with free formative

assessments—Personal Progress Checks—that teachers can assign throughout the year to measure student progress as they acquire content knowledge and develop skills.

## Enrolling Students: Equity and Access

College Board strongly encourages educators to make equitable access a guiding principle for their AP programs by giving all willing and academically prepared students the opportunity to participate in AP. We encourage the elimination of barriers that restrict access to AP for students from ethnic, racial, and socioeconomic groups that have been traditionally underserved. College Board also believes that all students should have access to academically challenging coursework before they enroll in AP classes, which can prepare them for AP success. It is only through a commitment to equitable preparation and access that true equity and excellence can be achieved.

## Offering AP Courses: The AP Course Audit

The AP Program unequivocally supports the principle that each school implements its own curriculum that will enable students to develop the content understandings and skills described in the course framework.

While the unit sequence represented in this publication is optional, the AP Program does have a short list of curricular and resource requirements that must be fulfilled before a school can label a course “Advanced Placement” or “AP.” Schools wishing to offer AP courses must participate in the AP Course Audit, a process through which AP teachers’ course materials are reviewed by college faculty. The AP Course Audit was created to provide teachers and administrators with clear guidelines on curricular and resource requirements for AP courses and to help colleges and universities validate courses marked “AP” on students’ transcripts. This process ensures that AP teachers’ courses meet or exceed the curricular and resource expectations that college and secondary school faculty have established for college-level courses.



The AP Course Audit form is submitted by the AP teacher and the school principal (or designated administrator) to confirm awareness and understanding of the curricular and resource requirements. A syllabus or course outline, detailing how course requirements are met, is submitted by the AP teacher for review by college faculty.

Please visit [collegeboard.org/apcourseaudit](https://collegeboard.org/apcourseaudit) for more information to support the preparation and submission of materials for the AP Course Audit.

## How the AP Program Is Developed

The scope of content for an AP course and exam is derived from an analysis of hundreds of syllabi and course offerings of colleges and universities. Using this research and data, a committee of college faculty and expert AP teachers work within the scope of the corresponding college course to articulate what students should know and be able to do upon the completion of the AP course. The resulting course framework is the heart of this course and exam description and serves as a blueprint of the content and skills that can appear on an AP Exam.

The AP Test Development Committees are responsible for developing each AP Exam, ensuring the exam questions are aligned to the course framework. The AP Exam development process is a multiyear endeavor; all AP Exams undergo extensive review, revision, piloting, and analysis to ensure that questions are accurate, fair, and valid, and that there is an appropriate spread of difficulty across the questions.

Committee members are selected to represent a variety of perspectives and institutions (public and private, small and large schools and colleges), and a range of gender, racial/ethnic, and regional groups. A list of each subject’s current AP Test Development Committee members is available on [apcentral.collegeboard.org](https://apcentral.collegeboard.org).

Throughout AP course and exam development, College Board gathers feedback from various stakeholders in both secondary schools and higher education institutions. This feedback is carefully considered to ensure that AP courses and exams are able to provide students with a college-level learning experience and the opportunity to demonstrate their qualifications for advanced placement or college credit.

## How AP Exams Are Scored

The exam scoring process, like the course and exam development process, relies on the expertise of both AP teachers and college faculty. While multiple-choice questions are scored by machine, the free-response questions and through-course performance assessments, as applicable, are scored by thousands

of college faculty and expert AP teachers. Most are scored at the annual AP Reading, while a small portion are scored online. All AP Readers are thoroughly trained, and their work is monitored throughout the Reading for fairness and consistency. In each subject, a highly respected college faculty member serves as Chief Faculty Consultant and, with the help of AP Readers in leadership positions, maintains the accuracy of the scoring standards. Scores on the free-response questions and performance assessments are weighted and combined with the results of the computer-scored multiple-choice questions, and this raw score is converted into a composite AP score on a 1–5 scale.

AP Exams are **not** norm-referenced or graded on a curve. Instead, they are criterion-referenced, which means that every student who meets the criteria for an AP score of 2, 3, 4, or 5 will receive that score, no matter how many students that is. The criteria for the number of points students must earn on the AP Exam to receive scores of 3, 4, or 5—the scores that research consistently validates for credit and placement purposes—include:

- The number of points successful college students earn when their professors administer AP Exam questions to them.
- The number of points researchers have found to be predictive that an AP student will succeed when placed into a subsequent, higher-level college course.
- Achievement-level descriptions formulated by college faculty who review each AP Exam question.

## Using and Interpreting AP Scores

The extensive work done by college faculty and AP teachers in the development of the course and exam and throughout the scoring process ensures that AP Exam scores accurately represent students’ achievement in the equivalent college course. Frequent and regular research studies establish the validity of AP scores as follows:

AP Score	Credit Recommendation	College Grade Equivalent
5	Extremely well qualified	A
4	Well qualified	A–, B+, B
3	Qualified	B–, C+, C
2	Possibly qualified	n/a
1	No recommendation	n/a

While colleges and universities are responsible for setting their own credit and placement policies, most private colleges and universities award credit and/or advanced placement for AP scores of 3 or higher. Additionally, most states in the United States have adopted statewide credit policies that ensure college credit for scores of 3 or higher at public colleges and universities. To confirm a specific college's AP credit/placement policy, a search engine is available at [apstudent.org/creditpolicies](http://apstudent.org/creditpolicies).

### **BECOMING AN AP READER**

Each June, thousands of AP teachers and college faculty members from around the world gather for seven days in multiple locations to evaluate and score the free-response sections of the AP Exams. Ninety-eight percent of surveyed educators who took part in the AP Reading say it was a positive experience.

There are many reasons to consider becoming an AP Reader, including opportunities to:

- **Bring positive changes to the classroom:** Surveys show that the vast majority of returning AP Readers—both high school and college educators—make improvements to the way they teach or score because of their experience at the AP Reading.
- **Gain in-depth understanding of AP Exam and AP scoring standards:** AP Readers gain exposure to the quality and depth of the responses from the entire pool of AP Exam takers, and thus are better able to assess their students' work in the classroom.
- **Receive compensation:** AP Readers are compensated for their work during the Reading. Expenses, lodging, and meals are covered for Readers who travel.
- **Score from home:** AP Readers have online distributed scoring opportunities for certain subjects. Check [collegeboard.org/apreading](http://collegeboard.org/apreading) for details.
- **Earn Continuing Education Units (CEUs):** AP Readers earn professional development hours and CEUs that can be applied to PD requirements by states, districts, and schools.

### **How to Apply**

Visit [collegeboard.org/apreading](http://collegeboard.org/apreading) for eligibility requirements and to start the application process.

# AP Resources and Supports

---

By completing a simple activation process at the start of the school year, teachers and students receive access to a robust set of classroom resources.

## AP Classroom

**AP Classroom** is a dedicated online platform designed to support teachers and students throughout their AP experience. The platform provides a variety of powerful resources and tools to provide yearlong support to teachers and enables students to receive meaningful feedback on their progress.



### UNIT GUIDES

Appearing in this publication and on AP Classroom, these planning guides outline all required course content and skills, organized into commonly taught units. Each unit guide suggests a sequence and pacing of content, scaffolds skill instruction across units, organizes content into topics, and provides tips on taking the AP Exam.



### PERSONAL PROGRESS CHECKS

Formative AP questions for every unit provide feedback to students on the areas where they need to focus. Available online, Personal Progress Checks measure knowledge and skills through multiple-choice questions with rationales to explain correct and incorrect answers, and free-response questions with scoring information. Because the Personal Progress Checks are formative, the results of these assessments cannot be used to evaluate teacher effectiveness or assign letter grades to students, and any such misuses are grounds for losing school authorization to offer AP courses.\*



### PROGRESS DASHBOARD

This dashboard allows teachers to review class and individual student progress throughout the year. Teachers can view class trends and see where students struggle with content and skills that will be assessed on the AP Exam. Students can view their own progress over time to improve their performance before the AP Exam.



### AP QUESTION BANK

This online library of real AP Exam questions provides teachers with secure questions to use in their classrooms. Teachers can find questions indexed by course topics and skills, create customized tests, and assign them online or on paper. These tests enable students to practice and get feedback on each question.

---

\*To report misuses, please call, 877-274-6474 (International: +1- 212-632-1781).

## Digital Activation

In order to teach an AP class and make sure students are registered to take the AP Exam, teachers must first complete the digital activation process. Digital activation gives students and teachers access to resources and gathers students' exam registration information online, eliminating most of the answer sheet bubbling that has added to testing time and fatigue.

AP teachers and students begin by signing in to **My AP** and completing a simple activation process at the start of the school year, which provides access to all AP resources, including AP Classroom.

To complete digital activation:

- Teachers and students sign in to, or create, their College Board accounts.
- Teachers confirm that they have added the course they teach to their AP Course Audit account and have had it approved by their school's administrator.
- Teachers or AP Coordinators, depending on who the school has decided is responsible, set up class sections so students can access AP resources and have exams ordered on their behalf.
- Students join class sections with a join code provided by their teacher or AP coordinator.
- Students will be asked for additional registration information upon joining their first class section, which eliminates the need for extensive answer sheet bubbling on exam day.

While the digital activation process takes a short time for teachers, students, and AP coordinators to complete, overall it helps save time and provides the following additional benefits:

- **Access to AP resources and supports:** Teachers have access to resources specifically designed to support instruction and provide feedback to students throughout the school year as soon as activation is complete.
- **Streamlined exam ordering:** AP Coordinators can create exam orders from the same online class rosters that enable students to access resources. The coordinator reviews, updates, and submits this information as the school's exam order in the fall.
- **Student registration labels:** For each student included in an exam order, schools will receive a set of personalized AP ID registration labels, which replaces the AP student pack. The AP ID connects a student's exam materials with the registration information they provided during digital activation, eliminating the need for pre-administration sessions and reducing time spent bubbling on exam day.
- **Targeted Instructional Planning Reports:** AP teachers will get Instructional Planning Reports (IPRs) that include data on each of their class sections automatically rather than relying on special codes optionally bubbled in on exam day.

# Instructional Model

---

Integrating AP resources throughout the course can help students develop the science practices, skills, and conceptual understandings. The instructional model outlined below shows possible ways to incorporate AP resources into the classroom.



## Plan

Teachers may consider the following approaches as they plan their instruction before teaching each unit.

- Review the overview at the start of each **unit guide** to identify essential questions, conceptual understandings, and skills for each unit.
- Use the **Unit at a Glance** table to identify related topics that build toward a common understanding, and then plan appropriate pacing for students.
- Identify useful strategies in the **Instructional Approaches** section to help teach the concepts and skills.



## Teach

When teaching, supporting resources can be used to build students' conceptual understanding and mastery of skills.

- Use the topic pages in the **unit guides** to identify the required content.
- Integrate the content with a skill, considering any appropriate scaffolding.
- Employ any of the instructional strategies previously identified.
- Use the available resources on the topic pages to bring a variety of assets into the classroom.



## Assess

Teachers can measure student understanding of the content and skills covered in the unit and provide actionable feedback to students.

- At the end of each unit, use AP Classroom to assign students the online Personal Progress Checks, as homework or an in-class task.
- Provide question-level feedback to students through answer rationales; provide unit- and skill-level feedback using the performance dashboard.
- Create additional practice opportunities using the **AP Question Bank** and assign them through **AP Classroom**.

# About the AP Physics C: Electricity and Magnetism Course

---

AP Physics C: Electricity and Magnetism is a calculus-based, college-level physics course, especially appropriate for students planning to specialize or major in physical science or engineering. The course explores topics such as electrostatics; conductors, capacitors, and dielectrics; electric circuits; magnetic fields; and electromagnetism. Introductory differential and integral calculus is used throughout the course.

## College Course Equivalent

It is strongly recommended that Physics C: Electricity and Magnetism be taught as a second-year physics course. A first-year physics course aimed at developing a thorough understanding of important physical principles and that permits students to explore concepts in the laboratory provides a richer experience in the process of science and better prepares them for the more analytical approaches taken in AP Physics C: Electricity and Magnetism.

However, secondary school programs for the achievement of AP course goals can take other forms as well, and the imaginative teacher can design approaches that best fit the needs of his or her students. In some schools, AP Physics C: Electricity and Magnetism has been taught successfully as an intensive first-year course; but in this case there may not be enough time to cover the material in sufficient depth to reinforce the students' conceptual understanding or to provide adequate laboratory experiences. This approach can work for highly motivated, able students but is not generally recommended. Independent study or other first-year physics courses supplemented with extra work for individual motivated students are also possibilities that have been successfully implemented.

If AP Physics C: Electricity and Magnetism is taught as a second-year course, it is recommended that the course meet for at least 250 minutes per week (the equivalent of a 50-minute period every day). However, if it is to be taught as a first-year course, approximately 90 minutes per day (450 minutes per week) is recommended in order to devote sufficient time to study the material to an appropriate depth and allow time for labs. In a school that uses block scheduling, one of the AP Physics C courses, but not both, can be taught in a single semester.

Whichever approach is taken, the nature of the AP Physics C: Electricity and Magnetism course requires teachers to spend time on the extra preparation needed for both class and laboratory. AP teachers should have a teaching load that is adjusted accordingly.

## Prerequisites

Students should have taken or be concurrently taking calculus.

## Lab Requirement

AP Physics C: Electricity and Magnetism should include a hands-on laboratory component comparable to a semester-long introductory college-level physics laboratory. Students should spend a minimum of 25% of instructional time engaged in hands-on laboratory work. Students ask questions, make observations and predictions, design experiments, analyze data, and construct arguments in a collaborative setting, where they direct and monitor their progress. Each student should complete a lab notebook or portfolio of lab reports.

**AP PHYSICS C: ELECTRICITY AND MAGNETISM**

---

# Course Framework



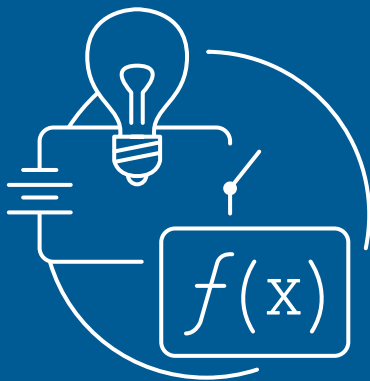

# Introduction

---

*The AP Physics C: Electricity and Magnetism course outlined in this framework reflects a commitment to what physics teachers, professors, and researchers have agreed is the main goal of a college-level physics course: to help students develop a deep understanding of the foundational principles that shape our understanding of electricity and magnetism. By confronting complex physical situations or scenarios, the course is designed to enable students to develop the ability to reason about physical phenomena using important science practices, such as creating and analyzing representations of physical scenarios, designing experiments, analyzing data, and using mathematics to model and to solve problems.*

To foster this deeper level of learning, the AP Physics C: Electricity and Magnetism course defines concepts, skills, and understandings required by representative colleges and universities for granting college credit and placement. Students will practice reasoning skills used by physicists by discussing and debating, with peers, the physical phenomena investigated in class, as well as by designing and conducting inquiry-based laboratory investigations to solve problems through first-hand observations, data collection, analysis, and interpretation.

This document is not a complete curriculum. Teachers create their own local curriculum by selecting, for each concept, content that enables students to explore the course learning objectives and meets state or local requirements. This result is a course that prepares students for college credit and placement.

# Course Framework Components

---

## Overview

This course framework provides a clear and detailed description of the course requirements necessary for student success. The framework specifies what students must know, be able to do, and understand to qualify for college credit or placement.

### The course framework includes two essential components:

#### 1 SCIENCE PRACTICES

The science practices are central to the study and practice of physics. Students should develop and apply the described skills on a regular basis over the span of the course.

#### 2 COURSE CONTENT

The course content is organized into commonly taught units of study that provide a suggested sequence for the course and detail required content and conceptual understandings that colleges and universities typically expect students to master to qualify for college credit and/or placement. This content is grounded in big ideas, which are cross-cutting concepts that build conceptual understanding and spiral throughout the course.

# 1

## AP PHYSICS C: ELECTRICITY AND MAGNETISM

# Science Practices

---

The table that follows presents the science practices that students should develop during the AP Physics C: Electricity and Magnetism course. These practices, and their related skills, form the basis of many tasks on the AP Physics C: Electricity and Magnetism Exam.

The unit guides that follow embed and spiral these science practices throughout the course, providing teachers with one way to integrate the skills into the course content with sufficient repetition to prepare students to transfer those skills when taking the AP Physics C: Electricity and Magnetism Exam.

More detailed information about teaching the science practices can be found in the Instructional Approaches section of this publication.



# AP PHYSICS C: ELECTRICITY AND MAGNETISM Science Practices

## Practice 1

### Visual Representations 1

Analyze and/or use (non-narrative/non-mathematical) representations of physical situations, excluding graphs.

## Practice 2

### Question and Method 2

Determine scientific questions and methods.

## Practice 3

### Representing Data and Phenomena 3

Create visual representations or models of physical situations.

## Practice 4

### Data Analysis 4

Analyze quantitative data represented in graphs.

## Practice 5

### Theoretical Relationships 5

Determine the effects on a quantity when another quantity or the physical situation changes.

## Practice 6

### Mathematical Routines 6

Solve problems of physical situations using mathematical relationships.

## Practice 7

### Argumentation 7

Develop an explanation or scientific argument.

## SKILLS

**1.A** Describe the physical meaning (includes identifying features) of a representation (not assessed on the AP Exam).

**1.B** Describe the relationship between different types of representations of the same physical situation.

**1.C** Demonstrate consistency between different types of representations of the same physical situation.

**1.D** Select relevant features of a representation to answer a question or solve a problem.

**1.E** Describe the effects of modifying conditions or features of a representation of a physical situation.

**2.A** Identify a testable scientific question or problem.

**2.B** Make a claim or predict the results of an experiment.

**2.C** Identify appropriate experimental procedures (which may include a sketch of a lab setup).

**2.D** Make observations or collect data from representations of laboratory setups or results.

**2.E** Identify or describe potential sources of experimental error.

**2.F** Explain modifications to an experimental procedure that will alter results.

**3.A** Select and plot appropriate data.

**3.B** Represent features of a model or the behavior of a physical system using appropriate graphing techniques, appropriate scale, and units.

**3.C** Sketch a graph that shows a functional relationship between two quantities.

**3.D** Create appropriate diagrams to represent physical situations.

**4.A** Identify and describe patterns and trends in data or a graph.

**4.B** Demonstrate consistency between different graphical representations of the same physical situation.

**4.C** Linearize data and/or determine a best fit line or curve.

**4.D** Select relevant features of a graph to describe a physical situation or solve problems.

**4.E** Explain how the data or graph illustrates a physics principle, process, concept, or theory.

**5.A** Select an appropriate law, definition, mathematical relationship, or model to describe a physical situation.

**5.B** Determine the relationship between variables within an equation when an existing variable changes.

**5.C** Determine the relationship between variables within an equation when a new variable is introduced.

**5.D** Determine or estimate the change in a quantity using a mathematical relationship.

**5.E** Derive a symbolic expression from known quantities by selecting and following a logical algebraic pathway.

**6.A** Extract quantities from narratives or mathematical relationships to solve problems.

**6.B** Apply an appropriate law, definition, or mathematical relationship to solve a problem.

**6.C** Calculate an unknown quantity with units from known quantities, by selecting and following a logical computational pathway.

**6.D** Assess the reasonableness of results or solutions.

**7.A** Make a scientific claim.

**7.B** Support a claim with evidence from experimental data.

**7.C** Support a claim with evidence from physical representations.

**7.D** Provide reasoning to justify a claim using physical principles or laws.

**7.E** Explain the connection between experimental results and larger physical principles, laws, or theories.

**7.F** Explain how potential sources of experimental error may affect results and/or conclusions.

## 2

# AP PHYSICS C: ELECTRICITY AND MAGNETISM

# Course Content

---

Based on the Understanding by Design® (Wiggins and McTighe) model, this course framework provides a clear and detailed description of the course requirements necessary for student success. The framework specifies what students must know, be able to do, and understand, with a focus on big ideas that encompass core principles, theories, and processes of the discipline. The framework also encourages instruction that prepares students to make connections across domains through a broader way of thinking about the physical world.

## Big Ideas

The big ideas serve as the foundation of the course and develop understanding as they spiral throughout the course. The big ideas enable students to create meaningful connections among course concepts. Often, these big ideas are abstract concepts or themes that become threads that run throughout the course. Revisiting the big ideas and applying them in a variety of contexts allows students to develop deeper conceptual understanding. Following are the big ideas of the course and a brief description of each.

### **BIG IDEA 1: CHANGE (CHG)**

Interactions produce changes in motion.

### **BIG IDEA 2: FORCE INTERACTIONS (ACT)**

Forces characterize interactions between objects or systems.

### **BIG IDEA 3: FIELDS (FIE)**

Fields predict and describe interactions.

### **BIG IDEA 4: CONSERVATION (CNV)**

Conservation laws constrain interactions.

## UNITS

The course content is organized into commonly taught units. The units have been arranged in a logical sequence frequently found in many college courses and textbooks.

The five units in AP Physics C: Electricity and Magnetism, and their weightings on the multiple-choice section of AP Exam, are listed below.

Pacing recommendations at the unit level and on the Course at Glance provide suggestions for how teachers can teach the required course content and administer the Personal Progress Checks. The suggested class periods are based on a schedule in which the class meets five days a week

for 45 minutes each day. While these recommendations have been made to aid in planning, teachers are free to adjust the pacing based on the needs of their students, alternate schedules (e.g., block scheduling), or their school's academic calendar.

## TOPICS

Each unit is divided into teachable segments called topics. Visit the topic pages (starting on p. 31) to see all required content for each topic. Although most topics can be taught in one or two class periods, teachers are again encouraged to pace the course to suit the needs of their students and school.

## Exam Weighting for the Multiple-Choice Section of the AP Exam

Units	Exam Weighting
<b>Unit 1:</b> <i>Electrostatics</i>	<b>26–34%</b>
<b>Unit 2:</b> <i>Conductors, Capacitors, Dielectrics</i>	<b>14–17%</b>
<b>Unit 3:</b> <i>Electric Circuits</i>	<b>17–23%</b>
<b>Unit 4:</b> <i>Magnetic Fields</i>	<b>17–23%</b>
<b>Unit 5:</b> <i>Electromagnetism</i>	<b>14–20%</b>

# Spiraling the Big Ideas

The following table shows how the big ideas spiral across units by showing the units in which each big idea appears.

Big Ideas	Unit 1	Unit 2	Unit 3	Unit 4	Unit 5
	<i>Electrostatics</i>	<i>Conductors, Capacitors, Dielectrics</i>	<i>Electric Circuits</i>	<i>Magnetic Fields</i>	<i>Electromagnetism</i>
<b>Change</b> <b>CHG</b>				✓	
<b>Force Interactions</b> <b>ACT</b>	✓	✓			✓
<b>Fields</b> <b>FIE</b>	✓	✓	✓	✓	✓
<b>Conservation</b> <b>CNV</b>	✓	✓	✓	✓	✓



# Course at a Glance

## Plan

The course at a glance provides a useful visual organization of the AP Physics C: Electricity and Magnetism curricular components, including:

- Sequence of units, along with approximate weighting and suggested pacing. Please note, pacing options are provided for teaching the course in a single semester or a full year.
- Progression of topics within each unit.
- Spiraling of the big ideas and science practices across units.

## Teach

### SCIENCE PRACTICES

Science practices are spiraled throughout the course.

<b>1</b> Visual Representations	<b>4</b> Data Analysis
<b>2</b> Question and Method	<b>5</b> Theoretical Relationships
<b>3</b> Representing Data and Phenomena	<b>6</b> Mathematical Routines
	<b>7</b> Argumentation

**+** Indicates 3 or more skills/practices suggested for a given topic. The individual topic page will show all the suggested skills.

### BIG IDEAS

Big Ideas spiral across topics and units.

<b>CHG</b> Change	<b>FIE</b> Fields
<b>ACT</b> Force Interactions	<b>CNV</b> Conservation

## Assess

Assign the Personal Progress Checks—either as homework or in class—for each unit. Each Personal Progress Check contains formative multiple-choice and free-response questions. The feedback from the Personal Progress Checks shows students the areas where they need to focus.

## UNIT 1

### Electrostatics

**~20/~40** Class Periods **26–34%** AP Exam Weighting

<b>ACT</b> <b>1</b> <b>6</b>	<b>1.1</b> Electrostatics: Charge and Coulomb's Law
<b>FIE</b> <b>+</b>	<b>1.2</b> Electrostatics: Electric Field and Electric Potential
<b>CNV</b> <b>+</b>	<b>1.3</b> Electrostatics: Electric Potential Due to Point Charges and Uniform Fields
<b>CNV</b> <b>1</b> <b>5</b>	<b>1.4</b> Electrostatics: Gauss's Law
<b>CNV</b> <b>6</b> <b>7</b>	<b>1.5</b> Electrostatics: Fields and Potentials of Other Charge Distributions

## UNIT 2

### Conductors, Capacitors, Dielectrics

**~9/~18** Class Periods **14–17%** AP Exam Weighting

<b>ACT</b> <b>+</b>	<b>2.1</b> Conductors, Capacitors, Dielectrics: Electrostatics with Conductors
<b>CNV</b> <b>+</b>	<b>2.2</b> Conductors, Capacitors, Dielectrics: Capacitors
<b>FIE</b> <b>+</b>	<b>2.3</b> Conductors, Capacitors, Dielectrics: Dielectrics

### Personal Progress Check 1

Multiple-Choice: ~35 questions  
Free-Response: 1 question

### Personal Progress Check 2

Multiple-Choice: ~30 questions  
Free-Response: 1 question

**UNIT  
3****Electric Circuits****~13/~26** Class Periods **17–23%** AP Exam Weighting

<b>FIE</b> +	<b>3.1</b> Electric Circuits: Current and Resistance
<b>CNV</b> +	<b>3.2</b> Electric Circuits: Current, Resistance, and Power
<b>CNV</b> +	<b>3.3</b> Electric Currents: Steady-State Direct- Current Circuits with Batteries and Resistors Only
<b>CNV</b> +	<b>3.4</b> Electrostatics: Gauss's Law

**Personal Progress Check 3**Multiple-Choice: ~35 questions  
Free-Response: 1 question**UNIT  
4****Magnetic Fields****~13/~26** Class Periods **17–23%** AP Exam Weighting

<b>CHG</b> +	<b>4.1</b> Magnetic Fields: Forces on Moving Charges in Magnetic Fields
<b>FIE</b> +	<b>4.2</b> Magnetic Fields: Forces on Current Carrying Wires in Magnetic Fields
<b>FIE</b> +	<b>4.3</b> Magnetic Fields: Fields of Long Current Carrying Wires
<b>CNV</b> 5 7	<b>4.4</b> Magnetic Fields: Biot–Savart Law and Ampère's Law

**Personal Progress Check 4**Multiple-Choice: ~30 questions  
Free-Response: 1 question**UNIT  
5****Electromagnetism****~10/~20** Class Periods **14–20%** AP Exam Weighting

<b>FIE</b> <b>CNV</b> <b>ACT</b> +	<b>5.1</b> Electromagnetism: Electromagnetic Induction (Including Faraday's Law and Lenz's Law)
<b>CNV</b> +	<b>5.2</b> Electromagnetism: Inductance (Including LR circuits)
<b>CNV</b> +	<b>5.3</b> Electromagnetism: Maxwell's Equations

**Personal Progress Check 5**Multiple-Choice: ~25 questions  
Free-Response: 1 question

THIS PAGE IS INTENTIONALLY LEFT BLANK.

## AP PHYSICS C: ELECTRICITY AND MAGNETISM

# Unit Guides

---

### Introduction

Designed with input from the community of AP Physics C: Electricity and Magnetism educators, the unit guides offer teachers helpful guidance in building students' skills and knowledge. The suggested sequence was identified through a thorough analysis of the syllabi of highly effective AP teachers and the organization of typical college textbooks.

This unit structure respects new AP teachers' time by providing one possible sequence they can adopt or modify rather than having to build from scratch. An additional benefit is that these units enable the AP Program to provide interested teachers with formative assessments—the Personal Progress Checks—that they can assign their students at the end of each unit to gauge progress toward success on the AP Exam. However, experienced AP teachers who are pleased with their current course organization and exam results should feel no pressure to adopt these units, which comprise an optional sequence for this course.

# Using the Unit Guides

UNIT  
1

**26–34%** AP EXAM WEIGHTING

**~20/~40** CLASS PERIODS

## Electrostatics

**Developing Understanding**

In Unit 1, students will begin the study of electric force, which acts on all objects with a property called charge. The electric force, in contrast to gravitational force, is one of attraction or repulsion and therefore leads to different effects on objects. This knowledge will help students understand the role electrostatics has in common devices such as photocopiers, defibrillators, and printers, as well as television, radio, and radar industries. In the units that follow, students will apply their knowledge of electric charges and force to electric circuits, and how the motion of electric charges helps create magnetic fields.

**Building the Science Practices**

Physicists often create and use representations and models to analyze phenomena, make predictions, and communicate ideas. Unit 1 provides multiple opportunities for students to create and use visual representations to demonstrate an understanding of the relationships between the variables that describe the motion of objects or systems.

Unit 1 will also teach students to demonstrate consistency between different graphical representations of the same physical situation. Being able to identify, create, and use graphs that represent the same physical situation demonstrates a deeper understanding of concepts than simply creating or using one representation. Introducing this skill in Unit 1 is important because identifying consistencies and creating graphs that are consistent with each other gets easier with practice.

Lastly, students will practice and be challenged to identify which fundamental law, definition, and/or mathematical relationship will apply to in a given situation. Selecting the

**Preparing for the AP Exam**

By the end of this unit, students should be able to create, describe, analyze, interpret, and make connections between representations and models, including electric field and electric potential diagrams. Equally important is how students label and construct such visual representations. Labels shouldn't contain logical flaws, biases, or inconsistencies, and diagrams should be constructed using conventional symbols such as arrows, boundaries, axes, and particles that clearly communicate significant features of the phenomenon or system.

Identifying patterns, trends, and anomalies is another skill that will appear on the AP Exam. However, students often struggle to create effective graphs. It's essential that scaffolded instruction is provided to help them choose appropriate quantities and labels (with units), correctly plot given data points, draw a best-fit line, use scales that span the data, and to include values in the range and domain necessary for the reasonable interpretation of the data.

**Force Interactions**

- Why does your hair stand up after brushing it with a plastic comb?

**Field**

- How does a charged rubber rod bend a stream of water?

**Conservation**

- How is the kinematics of charged particles used in old televisions?
- Why is it sometimes necessary to shield against electric fields?
- How are maps of voltage and topographical maps related?
- Why can a bird stand on a high voltage wire and not be electrocuted?

AP Physics C: Electricity and Magnetism Course and Exam Description
Course Framework V.1 | 27

## UNIT OPENERS

**Developing Understanding** provides an overview that contextualizes and situates the key content of the unit within the scope of the course.

**Big ideas** serve as the foundation of the course and develop understanding as they spiral throughout the course. The **essential questions** are thought-provoking questions that motivate students and inspire inquiry.

**Building the Science Practices** describes specific aspects of the practices that are appropriate to focus on in that unit.

**Preparing for the AP Exam** provides helpful tips and common student misunderstandings identified from prior exam data.

UNIT  
1

**Electrostatics**

### UNIT AT A GLANCE

	Topic	Suggested Skills	Class Periods
ACT-1	1.1 Electrostatics: Charge and Coulomb's Law	<ul style="list-style-type: none"> <li>1.A Describe the physical meaning (includes identifying features) of a representation.</li> <li>1.B Apply an appropriate law, definition, or mathematical relationship to solve a problem.</li> <li>1.C Calculate an unknown quantity with units from known quantities, by selecting and following a logical computational pathway.</li> </ul>	~20/~40 CLASS PERIODS
FIE-1	1.2 Electrostatics: Electric Field and Electric Potential	<ul style="list-style-type: none"> <li>1.A Describe the physical meaning (includes identifying features) of a representation.</li> <li>1.B Select and plot appropriate data.</li> <li>1.C Create appropriate diagrams to represent physical situations.</li> <li>1.D Identify and describe patterns and trends in data or a graph.</li> <li>1.E Demonstrate consistency between different graphical representations of the same physical situation.</li> <li>1.F Apply an appropriate law, definition, or mathematical relationship to solve a problem.</li> <li>1.G Calculate an unknown quantity with units from known quantities, by selecting and following a logical computational pathway.</li> </ul>	continued on next page

28 | Course Framework V.1
AP Physics C: Electricity and Magnetism Course and Exam Description

The **Unit at a Glance** table shows the topics, related enduring understandings, and suggested skills. The "class periods" column has been left blank so teachers can customize the time they spend on each topic.

The **suggested skills** show how teachers can link the content in that topic to specific skills, which have been thoughtfully chosen in a way to allow teachers to scaffold those skills throughout the course. The questions on the Personal Progress Checks are based on this.

# Using the Unit Guides

**UNIT**  
**1**

**Electrostatics**

---

### SAMPLE INSTRUCTIONAL ACTIVITIES

The sample activities on this page are optional and are offered to provide possible ways to incorporate instructional approaches into the classroom. Teachers do not need to use these activities or instructional approaches and are free to alter or edit them. The examples below were developed in partnership with teachers from the AP community to share ways that they approach teaching some of the topics in this unit. Please refer to the Instructional Approaches section beginning on p. 107 for more examples of activities and strategies.

Activity	Topic	Sample Activity
1	1.1	<b>Desktop Experiment</b> Give two pith balls some amount of charge (assumed to be equal charges) and hold them near each other. Have students measure the angle their strings make, and use this information to determine the charge on the pith balls. Also have them determine what fraction of the pith ball's electrons were lost/gained assuming one electron for every $3.3 \times 10^{-27}$ kg of mass.
2	1.1	<b>Qualitative Reasoning</b> Have students consider a situation where two metal spheres (one heavy, one light) have unequal-magnitude, opposite charges and are set at rest near each other in space. Students draw acceleration versus time and velocity versus time graphs for the time when the light sphere attracts, collides elastically with, and then repels from the heavier sphere.
3	1.2	<b>Changing Representations</b> Have students use the Charges and Fields PHET or the applet at <a href="http://flashphysics.org/electricField.html">flashphysics.org/electricField.html</a> to investigate electric field and potential (and their relationship) in the vicinity of equal or unequal two- or three-charge systems.
4	1.2	<b>Desktop Experiment</b> Connect two electrodes to a 9-V battery and immerse them in a plastic pan of water that is less than 1 cm deep. Use a voltmeter (negative connected to the negative of the battery) to probe the electric potential at various points in the water. Have students construct an electric potential isovalue map and estimate the strength of the electric field at various locations.
5	1.4	<b>Create a Plan</b> Have students research the electric field strength and direction at ground level on Earth. Next, have them use Gauss's Law to determine the net charge on Earth.

✍️

Unit Planning Notes

Use the space below to plan your approach to the unit.

---



---



---

30 | Course Framework V.1
AP Physics C: Electricity and Magnetism Course and Exam Description

The **Sample Instructional Activities** page includes activities that help teachers tie together the content and skill of a particular topic.

**Electrostatics**

**UNIT**  
**1**

---

## TOPIC 1.1 Electrostatics: Charge and Coulomb's Law

### Required Course Content

ENDURING UNDERSTANDING

**ACER** Objects with an electric charge will interact with each other by exerting forces on each other.

LEARNING OBJECTIVE

**ACER.1.A** Describe behavior of charges or system of charged objects interacting with each other.

**ACER.1.B** Explain and/or describe the behavior of a neutral object in the presence of a charged object or a system of charges.

ESSENTIAL KNOWLEDGE

**ACER.1.A.1** Particles and objects may contain electrostatic charges. The Law of Electrostatics states that like charges repel and unlike charges attract through electrostatic interactions.

**ACER.1.B.1** The presence of an electric field will polarize a neutral object (conductor or insulator). This can create an "induced" charge on the surface of the object.

a. As a consequence of this polarization, a charged object can interact with a neutral object, producing a net attraction between the charged object and the neutral object.

continued on next page

SUGGESTED SKILLS

👁️ **Visual Representations:** Describe the physical meaning (includes identifying features) of a representation.  
📐 **Mathematical Routines:** Apply an appropriate law, definition, or mathematical relationship to solve a problem.  
🧮 **Calculations:** Calculate an unknown quantity with units from known quantities, by selecting and following a logical computational pathway.

AVAILABLE RESOURCES

Classroom Resources >  
 • AP Physics 1 and 2 Lab Manual  
 • Critical Thinking Concepts in Physics  
 • Electrostatics  
 • Physics Instruction Using Video Analysis Technology  
 • Teaching Strategies for Limited Class Time

## TOPIC PAGES

The **suggested skills** offer possible skills to pair with the topic.

**Enduring Understandings** are the long-term takeaways related to the big ideas that leave a lasting impression on students. Students build and earn these understandings over time by exploring and applying course content throughout the year.

**Learning objectives** define what a student needs to be able to do with content knowledge in order to progress toward the enduring understandings.

**Essential knowledge** statements describe the knowledge required to perform the learning objective.

Where possible, **available resources** might help teachers address a particular topic.

AP Physics C: Electricity and Magnetism Course and Exam Description

Course Framework V.1 | 23

[Return to Table of Contents](#)

© 2019 College Board

## REQUIRED COURSE CONTENT LABELING SYSTEM

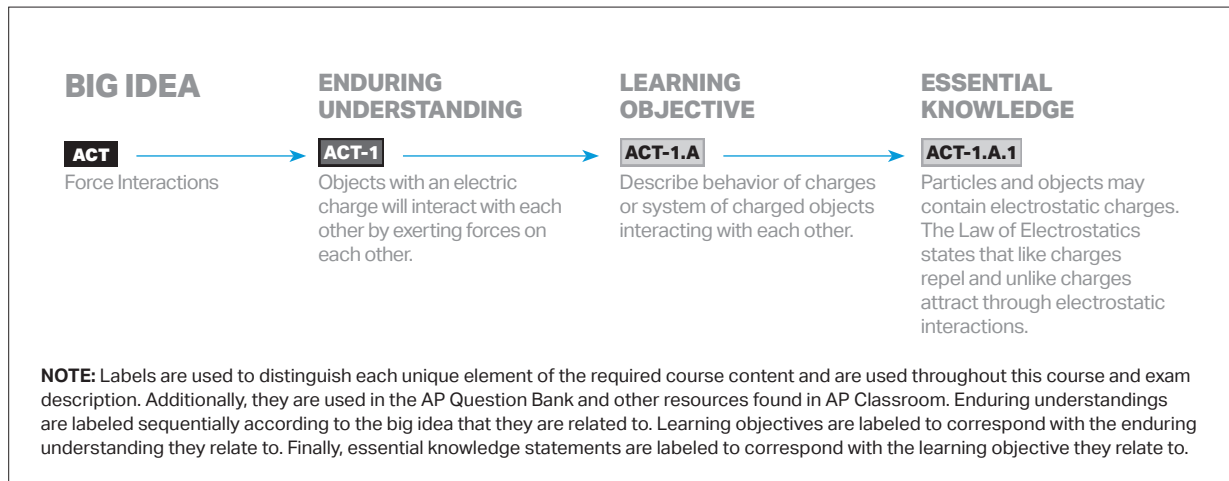

# AP PHYSICS C: ELECTRICITY AND MAGNETISM

## UNIT 1

# Electrostatics



**26–34%**  
AP EXAM WEIGHTING



**~20/~40**  
CLASS PERIODS

---



The icon consists of a white circle containing a blue square with the letters 'AP' in white. Below the square is a small blue monitor icon with two lines representing a screen and a base.

Remember to go to [AP Classroom](#) to assign students the online **Personal Progress Check** for this unit.

Whether assigned as homework or completed in class, the **Personal Progress Check** provides each student with immediate feedback related to this unit's topic and skills.

### **Personal Progress Check 1**

**Multiple-Choice: ~35 questions**

**Free-Response: 1 question**

# Electrostatics



## Developing Understanding

### BIG IDEA 2

#### Force Interactions **ACT**

- Why does your hair stand up after brushing it with a plastic comb?

### BIG IDEA 3

#### Fields **FIE**

- How does a charged rubber rod bend a stream of water?

### BIG IDEA 4

#### Conservation **CNV**

- How is the kinematics of charged particles used in old televisions?
- Why is it sometimes necessary to shield against electric fields?
- How are maps of voltage and topographical maps related?
- Why can a bird land on a high voltage wire and not be electrocuted?

In Unit 1, students will begin the study of electric force, which acts on all objects with a property called charge. The electric force, in contrast to gravitational force, is one of attraction or repulsion and therefore leads to different effects on objects. This knowledge will help students understand the role electrostatics has in common devices such as photocopiers, defibrillators, and printers, as well as television, radio, and radar industries. In the units that follow, students will apply their knowledge of electric charges and force to electric circuits, and how the motion of electric charges helps create magnetic fields.

## Building the Science Practices

3.A 4.B 6.B

Physicists often create and use representations and models to analyze phenomena, make predictions, and communicate ideas. Unit 1 provides multiple opportunities for students to create and use visual representations to demonstrate an understanding of the relationships between the variables that describe the motion of objects or systems.

Unit 1 will also teach students to demonstrate consistency between different graphical representations of the same physical situation. Being able to identify, create, and use graphs that represent the same physical situation demonstrates a deeper understanding of concepts than simply creating or using one representation. Introducing this skill in Unit 1 is important because identifying consistencies and creating graphs that are consistent with each other gets easier with practice.

Lastly, students will practice and be challenged to identify which fundamental law, definition, and/or mathematical relationship will apply to in a given situation. Selecting the

appropriate solution technique is a critical problem-solving skill that should be given space to be developed.

## Preparing for the AP Exam

By the end of this unit, students should be able to create, describe, analyze, interpret, and make connections between representations and models, including electric field and electric potential diagrams. Equally important is how students label and construct such visual representations. Labels shouldn't contain logical flaws, biases, or inconsistencies, and diagrams should be constructed using conventional symbols such as arrows, boundaries, axes, and particles that clearly communicate significant features of the phenomenon or system.

Identifying patterns, trends, and anomalies is another skill that will appear on the AP Exam. However, students often struggle to create effective graphs. It's essential that scaffolded instruction is provided to help them choose appropriate quantities and labels (with units), correctly plot given data points, draw a best-fit line, use scales that span the data, and to include values in the range and domain necessary for the reasonable interpretation of the data.

## UNIT AT A GLANCE

Enduring Understanding	Topic	Suggested Skills	Class Periods
			~20/~40 CLASS PERIODS
ACT-1	1.1 Electrostatics: Charge and Coulomb’s Law	<p><b>1.A</b> Describe the physical meaning (includes identifying features) of a representation.</p> <p><b>6.B</b> Apply an appropriate law, definition, or mathematical relationship to solve a problem.</p> <p><b>6.C</b> Calculate an unknown quantity with units from known quantities, by selecting and following a logical computational pathway.</p>	
FIE-1	1.2 Electrostatics: Electric Field and Electric Potential	<p><b>1.A</b> Describe the physical meaning (includes identifying features) of a representation.</p> <p><b>3.A</b> Select and plot appropriate data.</p> <p><b>3.D</b> Create appropriate diagrams to represent physical situations.</p> <p><b>4.A</b> Identify and describe patterns and trends in data or a graph.</p> <p><b>4.B</b> Demonstrate consistency between different graphical representations of the same physical situation.</p> <p><b>6.B</b> Apply an appropriate law, definition, or mathematical relationship to solve a problem.</p> <p><b>6.C</b> Calculate an unknown quantity with units from known quantities, by selecting and following a logical computational pathway.</p>	

*continued on next page*

## UNIT AT A GLANCE *(cont'd)*

Enduring Understanding	Topic	Suggested Skills	Class Periods
CNV-1	<b>1.3 Electrostatics: Electric Potential Due to Point Charges and Uniform Fields</b>	<p><b>1.B</b> Describe the relationship between different types of representations of the same physical situation.</p> <p><b>5.A</b> Select an appropriate law, definition, mathematical relationship, or model to describe a physical situation.</p> <p><b>5.B</b> Determine the relationship between variables within an equation when an existing variable changes.</p> <p><b>5.C</b> Determine the relationship between variables within an equation when a new variable is introduced.</p> <p><b>6.B</b> Apply an appropriate law, definition, or mathematical relationship to solve a problem.</p> <p><b>6.C</b> Calculate an unknown quantity with units from known quantities, by selecting and following a logical computational pathway.</p>	<b>~20/~40</b> CLASS PERIODS
CNV-2	<b>1.4 Electrostatics: Gauss’s Law</b>	<p><b>1.A</b> Describe the physical meaning (includes identifying features) of a representation.</p> <p><b>5.A</b> Select an appropriate law, definition, mathematical relationship, or model to describe a physical situation.</p>	
CNV-3	<b>1.5 Electrostatics: Fields and Potentials of other charge distributions</b>	<p><b>6.B</b> Apply an appropriate law, definition, or mathematical relationship to solve a problem.</p> <p><b>7.A</b> Make a scientific claim.</p> <p><b>7.C</b> Support a claim with evidence from physical representations.</p> <p><b>7.D</b> Provide reasoning to justify a claim using physical principles or laws.</p>	
<p> Go to <a href="#">AP Classroom</a> to assign the <b>Personal Progress Check</b> for Unit 1. Review the results in class to identify and address any student misunderstandings.</p>			

## SAMPLE INSTRUCTIONAL ACTIVITIES

The sample activities on this page are optional and are offered to provide possible ways to incorporate instructional approaches into the classroom. Teachers do not need to use these activities or instructional approaches and are free to alter or edit them. The examples below were developed in partnership with teachers from the AP community to share ways that they approach teaching some of the topics in this unit. Please refer to the Instructional Approaches section beginning on p. 107 for more examples of activities and strategies.

Activity	Topic	Sample Activity
1	1.1	<b>Desktop Experiment</b> Give two pith balls some amount of charge (assumed to be equal charges) and hold them near each other. Have students measure the angle their strings make, and use this information to determine the charge on the pith balls. Also have them determine what fraction of the pith ball's electrons were lost/gained assuming one electron for every $3.3 \times 10^{-27}$ kg of mass.
2	1.1	<b>Qualitative Reasoning</b> Have students consider a situation where two metal spheres (one heavy, one light) have unequal-magnitude, opposite charges and are set at rest near each other in space. Students draw acceleration versus time and velocity versus time graphs for the time when the light sphere attracts, collides elastically with, and then repels from the heavier sphere.
3	1.2	<b>Changing Representations</b> Have students use the Charges and Fields PhET or the applet at <a href="https://www.flashphysics.org/electricField.html">flashphysics.org/electricField.html</a> to investigate electric field and potential (and their relationship) in the vicinity of equal or unequal two- or three-charge systems.
4	1.2	<b>Desktop Experiment</b> Connect two electrodes to a 9-V battery and immerse them in a plastic pan of water that is less than 1 cm deep. Use a voltmeter (negative connected to the negative of the battery) to probe the electric potential at various points in the water. Have students construct an electric potential isoline map and estimate the strength of the electric field at various locations.
5	1.4	<b>Create a Plan</b> Have students research the electric field strength and direction at ground level on Earth. Next, have them use Gauss's Law to determine the net charge on Earth.



### Unit Planning Notes

Use the space below to plan your approach to the unit.

---

---

---

## TOPIC 1.1

# Electrostatics: Charge and Coulomb's Law

## Required Course Content

### ENDURING UNDERSTANDING

**ACT-1**

Objects with an electric charge will interact with each other by exerting forces on each other.

### LEARNING OBJECTIVE

**ACT-1.A**

Describe behavior of charges or system of charged objects interacting with each other.

**ACT-1.B**

Explain and/or describe the behavior of a neutral object in the presence of a charged object or a system of charges.

### ESSENTIAL KNOWLEDGE

**ACT-1.A.1**

Particles and objects may contain electrostatic charges. The Law of Electrostatics states that like charges repel and unlike charges attract through electrostatic interactions.

**ACT-1.B.1**

The presence of an electric field will polarize a neutral object (conductor or insulator). This can create an "induced" charge on the surface of the object.

- a. As a consequence of this polarization, a charged object can interact with a neutral object, producing a net attraction between the charged object and the neutral object.

*continued on next page*

**SUGGESTED SKILLS**

 *Visual Representations*

**1.A** Describe the physical meaning (includes identifying features) of a representation.

 *Mathematical Routines*

**6.B** Apply an appropriate law, definition, or mathematical relationship to solve a problem.

**6.C** Calculate an unknown quantity with units from known quantities, by selecting and following a logical computational pathway.

**AVAILABLE RESOURCES**

Classroom Resources >

- [AP Physics 1 and 2 Lab Manual](#)
- [Critical Thinking Concepts in Physics](#)
- [Electrostatics](#)
- [Physics Instruction Using Video Analysis Technology](#)
- [Teaching Strategies for Limited Class Time](#)

## LEARNING OBJECTIVE

## ACT-1.C

- Calculate the net electrostatic force on a single point charge due to other point charges.
- Calculate unknown quantities such as the force acting on a specified charge or the distances between charges in a system of static point charges.

## ACT-1.D

Determine the motion of a charged object of specified charge and mass under the influence of an electrostatic force.

## ESSENTIAL KNOWLEDGE

## ACT-1.C.1

Point charge is defined as a charged object where the object is of negligible mass and size and takes up virtually no space.

- The magnitude of electrostatic force between two point charges is given by Coulomb's Law:

$$|\vec{F}_E| = \frac{1}{4\pi\epsilon_0} \left| \frac{q_1 q_2}{r^2} \right|$$

- Net force can be determined by superposition of all forces acting on a point charge due to the vector sum of other point charges.

## ACT-1.D.1

Knowing the force acting on the charged object and the initial conditions of the charged object (such as initial velocity), the motion of the object (characteristics such as the acceleration, velocity and velocity changes, and trajectory of the object) can be determined.

## TOPIC 1.2

# Electrostatics: Electric Field and Electric Potential

## Required Course Content

### ENDURING UNDERSTANDING

**FIE-1**

Objects with an electric charge will create an electric field.

### LEARNING OBJECTIVE

**FIE-1.A**

Using the definition of electric field, unknown quantities (such as charge, force, field, and direction of field) can be calculated in an electrostatic system of a point charge or an object with a charge in a specified electric field.

**FIE-1.B**

Describe and calculate the electric field due to a single point charge.

### ESSENTIAL KNOWLEDGE

**FIE-1.A.1**

The definition of electric field is defined as

$$\vec{E} = \frac{\vec{F}_E}{q}$$

where  $q$  is defined as a “test charge.”

- A test charge is a small positively charged object of negligible size and mass.
- The direction of an electric field is the direction in which a test charge would move if placed in the field.

**FIE-1.B.1**

The electric field of a single point charge can be determined by using the definition of the electric field and Coulomb’s Law.

$$|\vec{F}_E| = \frac{1}{4\pi\epsilon_0} \left| \frac{q_1 q_2}{r^2} \right|$$

*continued on next page*

**SUGGESTED SKILLS**

 *Visual Representations*

**1.A** Describe the physical meaning (includes identifying features) of a representation.

 *Representing Data and Phenomena*

**3.A** Select and plot appropriate data.

**3.D** Create appropriate diagrams to represent physical situations.

 *Data Analysis*

**4.A** Identify and describe patterns and trends in data or a graph.

**4.B** Demonstrate consistency between different graphical representations of the same physical situation.

 *Mathematical Routines*

**6.B** Apply an appropriate law, definition, or mathematical relationship to solve a problem.

**6.C** Calculate an unknown quantity with units from known quantities, by selecting and following a logical computational pathway.

**AVAILABLE RESOURCES**

Classroom Resources >

- [AP Physics 1 and 2 Lab Manual](#)
- [Conservation Concepts](#)
- [Critical Thinking Concepts in Physics](#)
- [Teaching Strategies for Limited Class Time](#)



**LEARNING OBJECTIVE****FIE-1.C**

Describe and calculate the electric field due to a dipole or a configuration of two or more static-point charges.

**FIE-1.D**

Explain or interpret an electric field diagram of a system of charges.

**FIE-1.E**

Sketch an electric-field diagram of a single point charge, a dipole, or a collection of static-point charges.

**FIE-1.F**

Determine the qualitative nature of the motion of a charged particle of specified charge and mass placed in a uniform electric field.

**FIE-1.G**

Sketch the trajectory of a known charged particle placed in a known uniform electric field.

**ESSENTIAL KNOWLEDGE****FIE-1.C.1**

The electric field, due to a configuration of static-point charges, can be determined by applying the definition of electric field and the principle of superposition using the vector nature of the fields.

**FIE-1.D.1**

Electric field lines have properties that show the relative magnitude of the electric field strength and the direction of the electric field vector at any position in the diagram.

**FIE-1.E.1**

Using the properties of electric field diagrams, a general field line diagram can be drawn for static-charged situations.

**FIE-1.F.1**

A charged particle in a uniform electric field will be subjected to a constant electrostatic force.

**FIE-1.G.1**

The trajectory of a charged particle can be determined when placed in a known uniform electric field.

- The initial conditions of motion are necessary to provide a complete description of the trajectory.
- The force acting on the particle will be a constant force.

## TOPIC 1.3

# Electrostatics: Electric Potential Due to Point Charges and Uniform Fields

## Required Course Content

### ENDURING UNDERSTANDING

#### CNV-1

The total energy of a system composed of a collection of point charges can transfer from one form to another without changing the total amount of energy in the system.

### LEARNING OBJECTIVE

#### CNV-1.A

Calculate the value of the electric potential in the vicinity of one or more point charges.

### ESSENTIAL KNOWLEDGE

#### CNV-1.A.1

The definition of electric potential at a particular location due to a single point charge is:

$$V = \frac{1}{4\pi\epsilon_0} \frac{q}{r}$$

a. The potential due to multiple point charges can be determined by the principle of superposition in scalar terms of the charges by using the following expression:

$$V = \frac{1}{4\pi\epsilon_0} \sum_i \frac{q_i}{r_i}$$

b. The electric potential is defined to be zero at an infinite distance from the point charge.

### SUGGESTED SKILLS

 *Visual Representations*

**1.B** Describe the relationship between different types of representations of the same physical situation.

 *Theoretical Relationships*

**5.A** Select an appropriate law, definition, mathematical relationship, or model to describe a physical situation.

**5.B** Determine the relationship between variables within an equation when an existing variable changes.

**5.C** Determine the relationship between variables within an equation when a new variable is introduced.

 *Mathematical Routines*

**6.B** Apply an appropriate law, definition, or mathematical relationship to solve a problem.

**6.C** Calculate an unknown quantity with units from known quantities, by selecting and following a logical computational pathway.



### AVAILABLE RESOURCES

Classroom Resources >

- [AP Physics 1 and 2 Lab Manual](#)
- [Conservation Concepts](#)
- [Critical Thinking Concepts in Physics](#)
- [Teaching Strategies for Limited Class Time](#)

*continued on next page*

## LEARNING OBJECTIVE

**CNV-1.B**

Mathematically represent the relationships between the electric charge, the difference in electric potential, and the work done (or electrostatic potential energy lost or gained) in moving a charge between two points in a known electric field.

**CNV-1.C**

- Calculate the electrostatic potential energy of a collection of two or more point charges held in a static configuration.
- Calculate the amount of work needed to assemble a configuration of point charges in some known static configuration.

**CNV-1.D**

Calculate the potential difference between two points in a uniform electric field and determine which point is at the higher potential.

**CNV-1.E**

Calculate the work done or changes in kinetic energy (or changes in speed) of a charged particle when it is moved through some known potential difference.

## ESSENTIAL KNOWLEDGE

**CNV-1.B.1**

The definition for stored electrostatic potential energy in an electrostatic system of a point charge and a known electric field is:

$$\Delta U = q\Delta V$$

**CNV-1.C.1**

The electrostatic potential energy of two point charges near each other is defined in this way:

$$U_E = \frac{1}{4\pi\epsilon_0} \frac{q_1 q_2}{r}$$

- The total potential energy of an arrangement of more than two charges is the scalar sum of all of the electrostatic potential energy interactions between each pair of charges.

**CNV-1.D.1**

The work done in moving a test charge between two points in a uniform electric field can be calculated.

- Use the definition of electric potential difference and the definition of a conservative field to determine the difference in electric potential in this case.

**CNV-1.E.1**

An electrostatic configuration or field is a conservative field, and the work done in an electric field in moving a known charge through a known electric field is equivalent to the potential energy lost or gained by that charge. Changes in kinetic energy can be determined by using the principle of conservation of energy.

*continued on next page*

**LEARNING OBJECTIVE****CNV-1.F**

- Describe the relative magnitude and direction of an electrostatic field given a diagram of equipotential lines.
- Describe characteristics of a set of equipotential lines given in a diagram of an electric field.
- Describe the general relationship between electric field lines and a set of equipotential lines for an electrostatic field.

**CNV-1.G**

- Use the general relationship between electric field and electric potential to calculate the relationships between the magnitude of electric field or the potential difference as a function of position.
- Use integration techniques to calculate a potential difference between two points on a line, given the electric field as a function of position on that line.

**ESSENTIAL KNOWLEDGE****CNV-1.F.1**

The characteristics and direction of an electric field can be determined from the characteristics of equipotential lines.

- The relative magnitude of an electric field can be determined by the gradient of the potential lines.
- The direction of the electric field is defined to be perpendicular to an equipotential line and pointing in the direction of the decreasing potential.

**CNV-1.G.1**

The general definition of potential difference that can be used in most cases is:

$$\Delta V = V_b - V_a = - \int_a^b \vec{E} \cdot d\vec{r}$$

or in the differential form:

$$E_x = - \frac{dV}{dx}$$

**SUGGESTED SKILLS**

 *Visual Representations*

**1.A** Describe the physical meaning (includes identifying features) of a representation.

 *Theoretical Relationships*

**5.A** Select an appropriate law, definition, mathematical relationship, or model to describe a physical situation.



**AVAILABLE RESOURCES**

Classroom Resources >

- [Conservation Concepts](#)
- [Critical Thinking Concepts in Physics](#)
- [Teaching Strategies for Limited Class Time](#)

# TOPIC 1.4

## Electrostatics:

# Gauss's Law

### Required Course Content

#### ENDURING UNDERSTANDING

**CNV-2**

There are laws that use symmetry and calculus to derive mathematical relationships that can be applied to physical systems containing electrostatic charge.

#### LEARNING OBJECTIVE

**CNV-2.A**

- a. State and apply the general definition of electric flux.
- b. Calculate the electric flux through an arbitrary area or through a geometric shape (e.g., cylinder, sphere).
- c. Calculate the flux through a rectangular area when the electric field is perpendicular to the rectangle and is a function of one position coordinate only.

**CNV-2.B**

Qualitatively apply Gauss's Law to a system of charges or charged region to determine characteristics of the electric field, flux, or charge contained in the system.

#### ESSENTIAL KNOWLEDGE

**CNV-2.A.1**

The general definition of electric flux is:

$$\Phi = \int \vec{E} \cdot d\vec{A}$$

- a. The definition for the total flux through a geometric closed surface is defined by the "surface integral" defined as:

$$\Phi_{\text{surface}} = \int \vec{E} \cdot d\vec{A}$$

- b. The sign of the flux is given by the dot product between the electric field vector and the area vector.
- c. The area vector is defined to be perpendicular to the plane of the surface and directed outward from a closed surface.

**CNV-2.B.1**

Gauss's Law can be defined in a qualitative way as the total flux through a closed Gaussian surface being proportional to the charge enclosed by the Gaussian surface. The flux is also independent of the size of the Gaussian shape.

*continued on next page*

**LEARNING OBJECTIVE****CNV-2.C**

State and use Gauss's Law in integral form to derive unknown electric fields for planar, spherical, or cylindrically symmetrical charge distributions.

**CNV-2.D**

- Using appropriate mathematics (which may involve calculus), calculate the total charge contained in lines, surfaces, or volumes when given a linear-charge density, a surface-charge density, or a volume-charge density of the charge configuration.
- Use Gauss's Law to calculate an unknown charge density or total charge on surface in terms of the electric field near the surface.

**CNV-2.E**

- Qualitatively describe electric fields around symmetrically (spherically, cylindrically, or planar) charged distributions.
- Describe the general features of an electric field due to symmetrically shaped charged distributions.

**CNV-2.F**

Describe the general features of an unknown charge distribution, given other features of the system.

**ESSENTIAL KNOWLEDGE****CNV-2.C.1**

Gauss's Law in integral form is:

$$\oint \vec{E} \cdot d\vec{A} = \frac{q_{\text{enclosed}}}{\epsilon_0}$$

**CNV-2.D.1**

In general, if a function of known charge density is given, the total charge can be determined using calculus, such as:

$$Q_t = \int \rho(r) dV$$

The above is the general case for a volume-charge distribution.

**CNV-2.E.1**

Gauss's Law can help in describing features of electric fields of charged systems at the surface, inside the surface, or at some distance away from the surface of charged objects.

$$\oint \vec{E} \cdot d\vec{A} = \frac{Q}{\epsilon_0} = \Phi_E$$

**CNV-2.F.1**

Gauss's law can be useful in determining the charge distribution that created an electric field, especially if the distribution is spherically, cylindrically, or planarly symmetric.

$$\oint \vec{E} \cdot d\vec{A} = \frac{Q}{\epsilon_0} = \Phi_E$$

## SUGGESTED SKILLS

 *Mathematical Routines*

**6.B** Apply an appropriate law, definition, or mathematical relationship to solve a problem.

 *Argumentation*

**7.A** Make a scientific claim.

**7.C** Support a claim with evidence from physical representations.

**7.D** Provide reasoning to justify a claim using physical principles or laws.



## AVAILABLE RESOURCES

Classroom Resources >

- [AP Physics 1 and 2 Lab Manual](#)
- [Conservation Concepts](#)
- [Critical Thinking Concepts in Physics](#)
- [Electrostatics](#)
- [Teaching Strategies for Limited Class Time](#)

## TOPIC 1.5

# Electrostatics: Fields and Potentials of Other Charge Distributions

## Required Course Content

### ENDURING UNDERSTANDING

#### CNV-3

There are laws that use calculus and symmetry to derive mathematical relationships that can be applied to electrostatic-charge distributions.

### LEARNING OBJECTIVE

#### CNV-3.A

Derive expressions for the electric field of specified charge distributions using integration and the principle of superposition. Examples of such charge distributions include a uniformly charged wire, a thin ring of charge (along the axis of the ring), and a semicircular or part of a semicircular arc.

### ESSENTIAL KNOWLEDGE

#### CNV-3.A.1

The electric field of any charge distribution can be determined using the principle of superposition, symmetry, and the definition of electric field due to a differential charge  $dq$ . One step in the solution is shown to be:

$$d\vec{E} = \frac{1}{4\pi\epsilon_0} \frac{dq}{r^2} \hat{r}$$

If this is applied appropriately and evaluated over the appropriate limits, the electric fields of the stated charge distributions can be determined as a function of position.

The following charge distributions can be explored using this method:

- a. An infinitely long, uniformly charged wire or cylinder determine field at distances along perpendicular bisector
- b. A thin ring of charge (along the axis of the ring)
- c. A semicircular or part of a semicircular arc
- d. A field due to a finitewire or line charge at a distance that is collinear with the line charge

*continued on next page*

**LEARNING OBJECTIVE****CNV-3.B**

- Identify and qualitatively describe situations in which the direction and magnitude of the electric field can be deduced from symmetry considerations and understanding the general behavior of certain charge distributions.
- Describe an electric field as a function of distance for the different types of symmetrical charge distributions.

**CNV-3.C**

- Derive expressions for the electric potential of a charge distribution using integration and the principle of superposition.
- Describe electric potential as a function of distance for the different types of symmetrical charge distributions.
- Identify regions of higher and lower electric potential by using a qualitative (or quantitative) argument to apply to the charged region of space.

**ESSENTIAL KNOWLEDGE****CNV-3.B.1**

The general characteristics of electric fields can be proven from the calculus definitions (or Gauss's Law) and/or the principle of superposition.

The following electric fields can be explored:

- Electric fields with planar symmetry, infinite sheets of charge, combinations of infinite sheets of charge, or oppositely charged plates
- Linearly charged wires or charge distributions
- Spherically symmetrical charge distributions on spheres or spherical shells of charge

**CNV-3.B.2**

Other distributions of charge that can be deduced using Gauss's Law or the principle of superposition.

**CNV-3.C.1**

The integral definition of the electric potential due to continuous charge distributions is defined as:

$$V = \frac{1}{4\pi\epsilon_0} \int \frac{dq}{r}$$

If this is applied appropriately and evaluated over the appropriate limits of integration, the potential due to the charge distribution can be determined as a function of position.

The following charge distributions can be explored using this method:

- A uniformly charged wire
- A thin ring of charge (along the axis of the ring)
- A semicircular arc or part of a semicircular arc
- A uniformly charged disk



THIS PAGE IS INTENTIONALLY LEFT BLANK.

**AP PHYSICS C: ELECTRICITY  
AND MAGNETISM**

**UNIT 2**

**Conductors,  
Capacitors,  
Dielectrics**



**14–17%**  
AP EXAM WEIGHTING



**~9/~18**  
CLASS PERIODS

---

The icon consists of a white circle containing a blue square with the letters 'AP' in white. Below the square are two horizontal lines representing a computer monitor.

Remember to go to [AP Classroom](#) to assign students the online **Personal Progress Check** for this unit.

Whether assigned as homework or completed in class, the **Personal Progress Check** provides each student with immediate feedback related to this unit's topic and skills.

### **Personal Progress Check 2**

**Multiple-Choice: ~30 questions**

**Free-Response: 1 question**

# Conductors, Capacitors, Dielectrics



## Developing Understanding

### BIG IDEA 2

#### Force Interactions **ACT**

- Why is the electric potential in the conductor connecting two resistors in series constant?
- Why is the electric field everywhere perpendicular to surfaces of constant electric potential?

### BIG IDEA 3

#### Fields **FIE**

- Why does water in a microwave oven become warm while aluminum foil sparks?

### BIG IDEA 4

#### Conservation **CNV**

- Why are capacitors used as circuit elements shaped like cylinders?

Previously, students investigated why all objects have an electric charge. In Unit 2, students will examine *how* that charge can move through an object. Conductors, capacitors, and dielectrics are presented to demonstrate that a charge's movement is dependent on an object's material. In electronics, each of these are important based on the type of movement or desired object behavior. Additionally, this unit examines how the behavior of these elements is impacted by electric fields. Students should be provided with opportunities (laboratory investigations or activities) to describe and examine the function of each of these elements, along with capacitors. Knowledge of conductors, capacitors, and dielectrics will prepare students for understanding how electric circuits work in Unit 3 and how they behave when one or more electrical element is altered or modified.

## Building the Science Practices

**1.E 2.E 7.B**

In this course, students will need scaffolded practice with modifying conditions or features of a representation of a physical situation. While it is important that students be able to calculate a numeric or symbolic solution to a problem, it is also vital that students are able to think about what would happen to their result if the initial conditions or assumptions—such as adding or removing friction, or the resistance of a wire being zero—were changed. Students should be able to justify their claims with evidence from experimental data, either collected in the lab or given to them as sample data. Students should also be able to show consistency between their claims made from experimental data and claims made by starting with the fundamental principles of physics.

In Unit 2, students should be able to make observations and collect data from representations of lab setups, as well as identify and/or describe potential sources of experimental error. Although detailed error analysis calculations will not be required on the exam, students should be able to

determine the relationship between variables within an equation when an existing variable changes.

## Preparing for the AP Exam

One of the free-response questions may ask students to justify the selection of data needed to answer a scientific question and design a plan for collecting that data. To better prepare students for this, it's recommended that teachers provide them with scaffolded activities and labs to determine the appropriate data needed to answer these questions. Teachers can refer to the learning objectives aligned to Unit 2 to create these activities.

Unit 2 also asks students to develop logical and coherent arguments. For example, students may have to make a claim about the capacitance of a capacitor with and without a dielectric, and justify it using scientific reasoning and evidence via physical principles or empirical data. If the scenario involves existing variables changing and/or being introduced, students could describe changes in the capacitance of a capacitor if the plates are moved closer together if a dielectric is introduced.

## UNIT AT A GLANCE

Enduring Understanding	Topic	Suggested Skills	Class Periods
ACT-2, ACT-3	<b>2.1 Conductors, Capacitors, Dielectrics: Electrostatics with Conductors</b>	<p><b>1.A</b> Describe the physical meaning (includes identifying features) of a representation.</p> <p><b>1.E</b> Describe the effects of modifying conditions or features of a representation of a physical situation.</p> <p><b>5.A</b> Select an appropriate law, definition, mathematical relationship, or model to describe a physical situation.</p> <p><b>7.C</b> Support a claim with evidence from physical representations.</p> <p><b>7.D</b> Provide reasoning to justify a claim using physical principles or laws.</p>	<b>~9/~18</b> CLASS PERIODS
CNV-4	<b>2.2 Conductors, Capacitors, Dielectrics: Capacitors</b>	<p><b>1.A</b> Describe the physical meaning (includes identifying features) of a representation.</p> <p><b>2.A</b> Identify a testable scientific question or problem.</p> <p><b>2.B</b> Make a claim or predict the results of an experiment.</p> <p><b>2.E</b> Identify or describe potential sources of experimental error.</p> <p><b>5.B</b> Determine the relationship between variables within an equation when an existing variable changes.</p> <p><b>7.A</b> Make a scientific claim.</p> <p><b>7.D</b> Provide reasoning to justify a claim using physical principles or laws.</p>	

*continued on next page*

UNIT AT A GLANCE *(cont'd)*

Enduring Understanding	Topic	Suggested Skills	Class Periods
F1E-2	2.3 Conductors, Capacitors, Dielectrics: Dielectrics	<p><b>2.B</b> Make a claim or predict the results of an experiment.</p> <p><b>3.C</b> Sketch a graph that shows a functional relationship between two quantities.</p> <p><b>3.D</b> Create appropriate diagrams to represent physical situations.</p> <p><b>5.B</b> Determine the relationship between variables within an equation when an existing variable changes.</p> <p><b>6.C</b> Calculate an unknown quantity with units from known quantities, by selecting and following a logical computational pathway.</p> <p><b>7.A</b> Make a scientific claim.</p> <p><b>7.B</b> Support a claim with evidence from experimental data.</p>	~9/~18 CLASS PERIODS
<p> Go to <a href="#">AP Classroom</a> to assign the <b>Personal Progress Check</b> for Unit 2. Review the results in class to identify and address any student misunderstandings.</p>			

## SAMPLE INSTRUCTIONAL ACTIVITIES

The sample activities on this page are optional and are offered to provide possible ways to incorporate instructional approaches into the classroom. Teachers do not need to use these activities or instructional approaches and are free to alter or edit them. The examples below were developed in partnership with teachers from the AP community to share ways that they approach teaching some of the topics in this unit. Please refer to the Instructional Approaches section beginning on p. 107 for more examples of activities and strategies.

Activity	Topic	Suggested Activity
1	2.1	<b>Predict and Explain</b> Find an enclosed metal wire mesh container that can fit a neon gas discharge tube. Zap the tube with a tesla coil to show it lighting up. Then put the tube in the wire mesh (have students predict what will happen); no amount of effort will cause the tube to light up from the tesla coil. Explain why.
2	2.2	<b>Create a Plan</b> Have students research the electric properties of the ionosphere and the Earth's surface and use their research to determine the following: The capacitance of the spherical system consisting of ionosphere and Earth's surface, and the charge and potential difference of the "capacitor."
3	2.2	<b>Desktop Experiment</b> Have students construct their own capacitor and predict its capacitance. Have them use a capacitance-meter to measure the capacitance.
4	2.3	<b>Construct an Argument</b> Have students explain why it is that pure water has such a high dielectric constant (answer: the polarity of the molecules). Also have them explain why impure water results in "leaky" capacitors made from a water dielectric (answer: the impurities conduct current).
5	2.3	<b>Desktop Experiment</b> Have students construct a parallel-plate capacitor out of two pieces of foil with a piece of paper between each piece. Have students measure the capacitance with a capacitance-meter. Next, have them increase the number of sheets of paper and record data with the purpose of finding the dielectric constant of the paper.



### Unit Planning Notes

Use the space below to plan your approach to the unit.

---

---

---

## TOPIC 2.1

# Conductors, Capacitors, Dielectrics: Electrostatics with Conductors

### Required Course Content

#### ENDURING UNDERSTANDING

##### ACT-2

Excess charge on an insulated conductor will spread out on the entire conductor until there is no more movement of the charge.

#### LEARNING OBJECTIVE

##### ACT-2.A

- Recognize that the excess charge on a conductor in electrostatic equilibrium resides entirely on the surface of a conductor.
- Describe the consequence of the law of electrostatics and that it is responsible for the other law of conductors (that states there is an absence of an electric field inside of a conductor).

#### ESSENTIAL KNOWLEDGE

##### ACT-2.A.1

The mutual repulsion of all charges on the surface of a conductor will eventually create a state of electrostatic equilibrium on the conductor. This will result in a uniform charge density for uniform shapes (spheres, cylinders, planes, etc.) and an absence of an electric field inside of all conductors (uniform or nonuniform shapes).

- The electric field just outside of a conductor must be completely perpendicular to the surface and have no components tangential to the surface. This is also a consequence of the electrostatic equilibrium on the surface of a conductor.

*continued on next page*

#### SUGGESTED SKILLS

 *Visual Representations*

**1.A** Describe the physical meaning (includes identifying features) of a representation.

**1.E** Describe the effects of modifying conditions or features of a representation of a physical situation.

 *Theoretical Relationships*

**5.A** Select an appropriate law, definition, mathematical relationship, or model to describe a physical situation.

 *Argumentation*

**7.C** Support a claim with evidence from physical representations.

**7.D** Provide reasoning to justify a claim using physical principles or laws.



#### AVAILABLE RESOURCES

Classroom Resources >

- [AP Physics 1 and 2 Lab Manual](#)
- [Conservation Concepts](#)
- [Critical Thinking Concepts in Physics](#)
- [Teaching Strategies for Limited Class Time](#)



**LEARNING OBJECTIVE****ACT-2.B**

- Explain why a conducting surface must be an equipotential surface.
- Describe the consequences of a conductor being an equipotential surface.
- Explain how a change to a conductor's charge density due to an external electric field will not change the electric-field value inside the conductor.

**ACT-2.C**

- Describe the process of charging a conductor by induction.
- Describe the net charge residing on conductors during the process of inducing a charge on an electroscope/conductor.

**ACT-2.D**

Explain how a charged object can attract a neutral conductor.

**ACT-2.E**

Describe the concept of electrostatic shielding.

**ESSENTIAL KNOWLEDGE****ACT-2.B.1**

An equipotential surface has the mathematical and physical property of having no electric field within the conductor (inside the metal and inside a cavity within the metal).

- The equipotential condition on a conductor remains, even if the conductor is placed in an external electric field.

**ACT-2.C.1**

A charge can be induced on a conductor by bringing a conductor near an external electric field and then simultaneously attaching a grounding wire/ground to the conductor.

**ACT-2.D.1**

A conductor can be completely polarized in the presence of an electric field.

- The complete polarization of the conductor is a consequence of the conductor remaining an equipotential in the presence of an external electric field.

**ACT-2.E.1**

Electrostatic shielding is the process of surrounding an area by a completely closed conductor to create a region free of an electric field.

*continued on next page*

## ENDURING UNDERSTANDING

### ACT-3

Excess charge on an insulated sphere or spherical shell will spread out on the entire surface of the sphere until there is no more movement of the charge because the surface is an equipotential.

## LEARNING OBJECTIVE

### ACT-3.A

- For charged conducting spheres or spherical shells, describe the electric field with respect to position.
- For charged conducting spheres or spherical shells, describe the electric potential with respect to position.

### ACT-3.B

Calculate the electric potential on the surfaces of two charged conducting spheres when connected by a conducting wire.

## ESSENTIAL KNOWLEDGE

### ACT-3.A.1

The electric field has a value of zero within a spherical conductor.

- The electric potential within a conducting sphere and on its surface is considered an equipotential surface. This implies that the potential inside of a conducting sphere is constant and is the same value as the potential on the surface of the sphere.

### ACT-3.B.1

The net charge in a system must remain constant. The entire system of connected spheres must be at the same potential.

- Charges will redistribute on two connected spheres until the two conditions above are met.

**SUGGESTED SKILLS**

 *Visual Representations*

**1.A** Describe the physical meaning (includes identifying features) of a representation.

 *Question and Method*

**2.A** Identify a testable scientific question or problem.

**2.B** Make a claim or predict the results of an experiment.

**2.E** Identify or describe potential sources of experimental error.

 *Theoretical Relationships*

**5.B** Determine the relationship between variables within an equation when an existing variable changes.

 *Argumentation*

**7.A** Make a scientific claim.

**7.D** Provide reasoning to justify a claim using physical principles or laws.



**AVAILABLE RESOURCES**

Classroom Resources >

- [AP Physics 1 and 2 Lab Manual](#)
- [Conservation Concepts](#)
- [Critical Thinking Concepts in Physics](#)
- [Teaching Strategies for Limited Class Time](#)

**TOPIC 2.2**

**Conductors, Capacitors, Dielectrics: Capacitors**

**Required Course Content**

**ENDURING UNDERSTANDING**

**CNV-4**

There are electrical devices that store and transfer electrostatic potential energy.

**LEARNING OBJECTIVE**

**CNV-4.A**

- a. Apply the general definition of capacitance to a capacitor attached to a charging source.
- b. Calculate unknown quantities such as charge, potential difference, or capacitance for physical system with a charged capacitor.

**CNV-4.B**

- a. Use the relationship for stored electrical potential energy for a capacitor.
- b. Calculate quantities such as charge, potential difference, capacitance, and potential energy of a physical system with a charged capacitor.

**ESSENTIAL KNOWLEDGE**

**CNV-4.A.1**

The general definition of capacitance is given by the following relationship:

$$C = \frac{Q}{\Delta V}$$

**CNV-4.B.1**

The energy stored in a capacitor is determined by the following relationship:

$$U_E = \frac{1}{2}C(\Delta V)^2$$

(or an equivalent expression)

*continued on next page*

## LEARNING OBJECTIVE

### CNV-4.C

Explain how a charged capacitor, which has stored energy, may transfer that energy into other forms of energy.

### CNV-4.D

- Derive an expression for a parallel-plate capacitor in terms of the geometry of the capacitor and fundamental constants.
- Describe the properties of a parallel-plate capacitor in terms of the electric field between the plates, the potential difference between the plates, the charge on the plates, and distance of separation between the plates.
- Calculate physical quantities such as charge, potential difference, electric field, surface area, and distance of separation for a physical system that contains a charged parallel-plate capacitor.
- Explain how a change in the geometry of a capacitor will affect the capacitance value.

### CNV-4.E

Apply the relationship between the electric field between the capacitor plates and the surface-charge density on the plates.

## ESSENTIAL KNOWLEDGE

### CNV-4.C.1

The conservation of charge and energy can be applied to a closed physical system containing charge, capacitors, and a source of potential difference.

### CNV-4.D.1

The general definition of capacitance can be used in conjunction with the properties of the electric field of two large oppositely charged plates to determine the general definition for the parallel-plate capacitor in terms of the geometry of that capacitor. The relationship is:

$$C = \frac{\epsilon_0 A}{d}$$

where  $A$  is the surface area of a plate and  $d$  is the distance of separation between the plates. The plates in a capacitor can be considered to have a very large surface area compared with the distance of separation between the plates. This condition makes this an ideal capacitor with a constant electric field between the plates.

### CNV-4.E.1

The electric field of oppositely charged plates can be determined by applying Gauss's Law or by applying the principle of superposition. The electric field between the two plates of a parallel-plate capacitor has the following properties:

- The electric field is constant in magnitude and is independent of the geometry of the capacitor.
- The electric field is proportional to the surface-charge density of the charge on one plate.

*continued on next page*

**LEARNING OBJECTIVE****CNV-4.F**

Derive expressions for the energy stored in a parallel-plate capacitor or the energy per volume of the capacitor.

**CNV-4.G**

- Describe the consequences to the physical system of a charged capacitor when a conduction slab is inserted between the plates or when the conducting plates are moved closer or farther apart.
- Calculate unknown quantities such as charge, potential difference, charge density, electric field, and stored energy when a conducting slab is placed in between the plates of a charged capacitor or when the plates of a charged capacitor are moved closer or farther apart.

**CNV-4.H**

Derive expressions for a cylindrical capacitor or a spherical capacitor in terms of the geometry of the capacitor and fundamental constants.

**CNV-4.I**

Calculate physical quantities such as charge, potential difference, electric field, surface area, and distance of separation for a physical system that contains a charged capacitor.

**ESSENTIAL KNOWLEDGE****CNV-4.F.1**

The energy of the parallel-plate capacitor can be expressed in terms of the fundamental properties of the capacitor (i.e., area, distance of separation), fundamental properties of the charged system (i.e., charge density), and fundamental constants.

**CNV-4.G.1**

The charged-capacitor system will have different conserved quantities depending on the initial conditions or conditions of the capacitor. If the capacitor remains attached to a source of a potential difference, then the charge in the system can change in accordance with the changes to the system. If the capacitor is isolated and unattached to a potential source, then the charge in the capacitor system remains constant and other physical quantities can change in response to changes in the physical system.

**CNV-4.H.1**

Using the definition of capacitance and the properties of electrostatics of charged cylinders or spheres, the capacitance of a cylindrical or spherical capacitor can also be determined in terms of its geometrical properties and fundamental constants.

**CNV-4.I.1**

The properties of capacitance still hold for all types of capacitors (spherical or cylindrical).

TOPIC 2.3

# Conductors, Capacitors, Dielectrics: Dielectrics

## Required Course Content

### ENDURING UNDERSTANDING

**FIE-2**

An insulator has different properties (than a conductor) when placed in an electric field.

### LEARNING OBJECTIVE

**FIE-2.A**

Describe and/or explain the physical properties of an insulating material when the insulator is placed in an external electric field.

**FIE-2.B**

Explain how a dielectric inserted in between the plates of a capacitor will affect the properties of the capacitor, such as potential difference, electric field between the plates, and charge on the capacitor.

### ESSENTIAL KNOWLEDGE

**FIE-2.A.1**

An insulator’s molecules will polarize to various degrees (slightly polarize or largely polarize). This effect is determined by a physical constant called the “dielectric constant.” The dielectric constant has values between 1 and larger numbers.

**FIE-2.B.1**

The dielectric will become partially polarized and create an electric field inside of the dielectric material. The net electric field between the plates of the capacitor is the resultant of the two fields—the fields between the plates and the induced field in the dielectric medium. This field is always a reduction in the field between the plate and therefore a reduction in the potential difference between the plates.

*continued on next page*

### SUGGESTED SKILLS

 *Question and Method*

**2.B** Make a claim or predict the results of an experiment.

 *Representing Data and Phenomena*

**3.C** Sketch a graph that shows a functional relationship between two quantities.

**3.D** Create appropriate diagrams to represent physical situations.

 *Theoretical Relationships*

**5.B** Determine the relationship between variables within an equation when an existing variable changes.

 *Mathematical Routines*

**6.C** Calculate an unknown quantity with units from known quantities, by selecting and following a logical computational pathway.

 *Argumentation*

**7.A** Make a scientific claim.

**7.B** Support a claim with evidence from experimental data.



### AVAILABLE RESOURCES

Classroom Resources >

- [AP Physics 1 and 2 Lab Manual](#)
- [Conservation Concepts](#)
- [Critical Thinking Concepts in Physics](#)
- [Teaching Strategies for Limited Class Time](#)

## LEARNING OBJECTIVE

## FIE-2.C

Use the definition of the capacitor to describe changes in the capacitance value when a dielectric is inserted between the plates.

## FIE-2.D

- Calculate changes in energy, charge, or potential difference when a dielectric is inserted into an isolated charge capacitor.
- Calculate changes in energy, charge, or potential difference when a dielectric is inserted into a capacitor that is attached to a source of potential difference.

## ESSENTIAL KNOWLEDGE

## FIE-2.C.1

The capacitance of a parallel-plate capacitor with a dielectric material inserted between the plates can be calculated as follows:

$$C = \frac{\kappa \epsilon_0 A}{d}$$

where the constant  $\kappa$  is the dielectric constant of the material.

## FIE-2.D.1

The initial condition of the capacitor system can determine which relationship to use when attempting to calculate unknown quantities in a capacitor system.

## AP PHYSICS C: ELECTRICITY AND MAGNETISM

# UNIT 3

# Electric Circuits



**17–23%**  
AP EXAM WEIGHTING



**~13/~26**  
CLASS PERIODS

---



The icon consists of a white circle containing a blue square with the letters 'AP' in white. Below the square is a small blue monitor icon with two lines representing a screen and a base.

Remember to go to [AP Classroom](#) to assign students the online **Personal Progress Check** for this unit.

Whether assigned as homework or completed in class, the **Personal Progress Check** provides each student with immediate feedback related to this unit's topic and skills.

### **Personal Progress Check 3**

**Multiple-Choice: ~35 questions**

**Free-Response: 1 question**

# Electric Circuits



## Developing Understanding

### BIG IDEA 3

#### Fields **FIE**

- How does the wiring design for a house allow for electricity to still be on in some rooms when others have none due to a circuit breaker being flipped?

### BIG IDEA 4

#### Conservation **CNV**

- Why do warming light bulbs take several minutes to shine bright?
- Why doesn't the electric company charge for electrons used?
- How does touching a conductor to a capacitor before removing it from a circuit protect you?

Whether or not they're aware, students interact with electric circuits regularly through charging their phones, powering up their laptops, or simply switching on a light. Unit 3 serves to illuminate how, and why, our various appliances function by exploring the nature and importance of electric currents, circuits, and resistance. Through activities and lab investigations, students will have opportunities to relate knowledge across the course by using the electrical components they learned about in Unit 2 and will come to discover in Unit 3 to create, modify, and analyze circuits. Students will also analyze the relationships that exist between current, resistance, and power, in addition to exploring and applying Ohm's Law and Kirchhoff's Rules.

## Building the Science Practices

**1.C 2.D 3.D**

Students are required to create representations to depict a physical situation, use that representation to solve problems, and be able to show consistency between multiple sets of representations of the same physical scenario. Demonstrating consistency between different types of representations of the same physical situation requires a deeper conceptual understanding than simply calculating a mathematical problem.

The analysis, interpretation, and application of quantitative information are vital skills for AP Physics students. Scientific inquiry experiences should be designed and implemented with increasing student involvement to help enhance inquiry learning and the development of critical thinking and problem-solving skills. The laboratory focus in Unit 3 guides students to make observations and collect data.

Unit 3 requires students to be familiar with collecting data and determining appropriate experimental procedures to answer scientific questions. To do so, students can be asked to analyze a familiar experiment by providing

a written explanation of how they would make observations or collect data in the given scenario.

## Preparing for the AP Exam

In Unit 3, students are expected to describe the physical meaning of representations and the relationship between them, while demonstrating consistency across them. This may include describing the relationship between circuit diagrams, equations, and a written description of a scenario, (and demonstrating consistency between them). Students are also expected to select relevant features of representations to solve problems.

Students should also be able to identify, describe, and compare patterns and trends in different plots (e.g., potential versus current and current versus resistance). Linearizing data collected to determine a best-fit line or curve is also a skill needed for the exam.

Often, the free-response questions have a mathematical focus, requiring students to, for instance, extract quantities from narratives or mathematical relationships (such as Ohm's Law and Kirchhoff's Rules), calculate and solve problems, and/or select an appropriate law, definition, or mathematical relationship or a model to describe a physical situation.

## UNIT AT A GLANCE

Enduring Understanding	Topic	Suggested Skills	Class Periods
			~13/~26 CLASS PERIODS
FIE-3	<b>3.1 Electric Circuits: Current and Resistance</b>	<p><b>3.A</b> Select and plot appropriate data.</p> <p><b>6.A</b> Extract quantities from narratives or mathematical relationships to solve problems.</p> <p><b>6.B</b> Apply an appropriate law, definition, or mathematical relationship to solve a problem.</p> <p><b>7.D</b> Provide reasoning to justify a claim using physical principles or laws.</p>	
CNV-5	<b>3.2 Electric Circuits: Current, Resistance, and Power</b>	<p><b>1.A</b> Describe the physical meaning (includes identifying features) of a representation.*</p> <p><b>1.C</b> Demonstrate consistency between different types of representations of the same physical situation.</p> <p><b>1.D</b> Select relevant features of a representation to answer a question or solve a problem.</p> <p><b>2.C</b> Identify appropriate experimental procedures (which may include a sketch of a lab setup).</p> <p><b>2.D</b> Make observations or collect data from representations of laboratory setups or results.</p> <p><b>3.A</b> Select and plot appropriate data.</p>	

\*Indicates a science practice not assessed with its paired topic on this unit's Personal Progress Check.

*continued on next page*

UNIT AT A GLANCE *(cont'd)*

Enduring Understanding	Topic	Suggested Skills	Class Periods
CNV-6	<b>3.3 Electric Currents: Steady-State Direct-Current Circuits with Batteries and Resistors Only</b>	<p><b>1.B</b> Describe the relationship between different types of representations of the same physical situation.</p> <p><b>2.F</b> Explain modifications to an experimental procedure that will alter results.</p> <p><b>3.B</b> Represent features of a model or the behavior of a physical system using appropriate graphing techniques, appropriate scale, and units.</p> <p><b>4.A</b> Identify and describe patterns and trends in data or a graph.</p> <p><b>4.B</b> Demonstrate consistency between different graphical representations of the same physical situation.</p> <p><b>4.C</b> Linearize data and/or determine a best fit line or curve.</p> <p><b>4.D</b> Select relevant features of a graph to describe a physical situation or solve problems.</p> <p><b>7.F</b> Explain how potential sources of experimental error may affect results and/or conclusions.</p>	~13/~26 CLASS PERIODS
CNV-7	<b>3.4 Capacitors in Circuits</b>	<p><b>1.A</b> Describe the physical meaning (includes identifying features) of a representation.</p> <p><b>1.D</b> Select relevant features of a representation to answer a question or solve a problem.</p> <p><b>2.D</b> Make observations or collect data from representations of laboratory setups or results.</p> <p><b>3.C</b> Sketch a graph that shows a functional relationship between two quantities.</p> <p><b>3.D</b> Create appropriate diagrams to represent physical situations.</p> <p><b>6.C</b> Calculate an unknown quantity with units from known quantities, by selecting and following a logical computational pathway.</p> <p><b>7.B</b> Support a claim with evidence from experimental data.</p>	
<p> Go to <a href="#">AP Classroom</a> to assign the <b>Personal Progress Check</b> for Unit 3. Review the results in class to identify and address any student misunderstandings.</p>			

## SAMPLE INSTRUCTIONAL ACTIVITIES

The sample activities on this page are optional and are offered to provide possible ways to incorporate instructional approaches into the classroom. Teachers do not need to use these activities or instructional approaches and are free to alter or edit them. The examples below were developed in partnership with teachers from the AP community to share ways that they approach teaching some of the topics in this unit. Please refer to the Instructional Approaches section beginning on p. 107 for more examples of activities and strategies.

Activity	Topic	Suggested Activity
1	3.1	<b>Desktop Experiment</b> Give students water, modeling clay, or a related substance and ask them to determine whether the substance is ohmic by applying various voltages and measuring the resulting current.
2	3.2	<b>Changing Representations</b> Have students solve a typical multi-loop circuit problem with batteries and resistors. Then have students construct a representation for each possible loop that visually shows Kirchhoff's Loop Rule and a representation for each junction that visually shows Kirchhoff's Junction Rule.
3	3.3	<b>Construct an Argument</b> Have students explain why a small 1-ohm resistor can only handle a small amount of power (such as $\frac{1}{4}$ watt) and why a large 1-ohm resistor can handle a large power (such as 30 watts). Have students explain why computer processors have "heat sinks" attached to them.
4	3.4	<b>Desktop Experiment</b> Have students use a known capacitor charged and connected directly to a voltmeter to determine the voltmeter's (high) internal resistance. This is done by taking voltage versus time data as the capacitor discharges through the meter and using the data to find the time constant $RC$ , then $R$ .



### Unit Planning Notes

Use the space below to plan your approach to the unit.

---

---

---

## TOPIC 3.1

**Electric Circuits: Current and Resistance****Required Course Content****ENDURING UNDERSTANDING****FIE-3**

The rate of charge flow through a conductor depends on the physical characteristics of the conductor.

**LEARNING OBJECTIVE****FIE-3.A**

- Calculate unknown quantities relating to the definition of current.
- Describe the relationship between the magnitude and direction of current to the rate of flow of positive or negative charge.

**FIE-3.B**

- Describe the relationship between current, potential difference, and resistance of resistor using Ohm's Law.
- Apply Ohm's Law in an operating circuit with a known resistor or resistances.

**ESSENTIAL KNOWLEDGE****FIE-3.A.1**

The definition of current is:

$$I = \frac{dQ}{dt}$$

Conventional current is defined as the direction of positive charge flow.

**FIE-3.B.1**

Ohm's Law is defined as:

$$I = \frac{\Delta V}{R}$$

**SUGGESTED SKILLS**

 *Representing Data and Phenomena*

**3.A** Select and plot appropriate data.

 *Mathematical Routines*

**6.A** Extract quantities from narratives or mathematical relationships to solve problems.

**6.B** Apply an appropriate law, definition, or mathematical relationship to solve a problem.

 *Argumentation*

**7.D** Provide reasoning to justify a claim using physical principles or laws.

**AVAILABLE RESOURCES**

Classroom Resources >

- [AP Physics 1 and 2 Lab Manual](#)
- [Conservation Concepts](#)
- [Critical Thinking Concepts in Physics](#)
- [Teaching Strategies for Limited Class Time](#)

*continued on next page*

## LEARNING OBJECTIVE

## FIE-3.C

- Explain how the properties of a conductor affect resistance.
- Compare resistances of conductors with different geometries or material.
- Calculate the resistance of a conductor of known resistivity and geometry.

## FIE-3.D

Describe the relationship between the electric field strength through a conductor and the current density within the conductor.

## FIE-3.E

Using the microscopic definition of current in a conductor, describe the properties of the conductor and the idea of “drift velocity.”

## FIE-3.F

Derive the expression for resistance of a conductor of uniform cross-sectional area in terms of its dimensions and resistivity.

## ESSENTIAL KNOWLEDGE

## FIE-3.C.1

The definition of resistance in terms of the properties of the conductor is:

$$R = \frac{\rho \ell}{A}$$

where  $\rho$  is defined as the resistivity of the conductor.

## FIE-3.D.1

The relationship that defines current density (current per cross-sectional area) in a conductor is:

$$\vec{E} = \rho \vec{J}.$$

Notice that current density is a vector, whereas current is a scalar.

## FIE-3.E.1

The definition of current in a conductor is:

$$I = Ne v_d A$$

where  $N$  is the number of charge carriers per unit volume,  $e$  is the charge on electron,  $A$  is the cross-sectional area, and  $v_d$  is the drift velocity of electrons.

## FIE-3.F.1

The definition of resistance can be derived using the microscopic definition of current and the relationship between electric field and current density.

## TOPIC 3.2

# Electric Circuits: Current, Resistance, and Power

## Required Course Content

### ENDURING UNDERSTANDING

**CNV-5**

There are electrical devices that convert electrical potential energy into other forms of energy.

### LEARNING OBJECTIVE

**CNV-5.A**

- Derive expressions that relate current, voltage, and resistance to the rate at which heat is produced in a resistor.
- Calculate different rates of heat production for different resistors in a circuit.

**CNV-5.B**

Calculate the amount of heat produced in a resistor given a known time interval and the circuit characteristics.

### ESSENTIAL KNOWLEDGE

**CNV-5.A.1**

The definition of power or the rate of heat loss through a resistor is:

$$P = I\Delta V$$

or an equivalent expression that can be simplified using Ohm's Law.

**CNV-5.B.1**

The total amount of heat energy transferred from electrical potential energy to heat can be determined using the definition of power.

**SUGGESTED SKILLS**

 *Visual Representations*

**1.A** Describe the physical meaning (includes identifying features) of a representation.

**1.C** Demonstrate consistency between different types of representations of the same physical situation.

**1.D** Select relevant features of a representation to answer a question or solve a problem.

 *Question and Method*

**2.C** Identify appropriate experimental procedures (which may include a sketch of a lab setup).

**2.D** Make observations or collect data from representations of laboratory setups or results.

 *Representing Data and Phenomena*

**3.A** Select and plot appropriate data.

**AVAILABLE RESOURCES**

Classroom Resources >

- AP Physics 1 and 2 Lab Manual
- Conservation Concepts
- Critical Thinking Concepts in Physics
- Teaching Strategies for Limited Class Time



## SUGGESTED SKILLS

 *Visual Representations*

**1.B** Describe the relationship between different types of representations of the same physical situation.

 *Question and Method*

**2.F** Explain modifications to an experimental procedure that will alter results.

 *Representing Data and Phenomena*

**3.B** Represent features of a model or the behavior of a physical system using appropriate graphing techniques, appropriate scale, and units.

 *Data Analysis*

**4.A** Identify and describe patterns and trends in data or a graph.

**4.B** Demonstrate consistency between different graphical representations of the same physical situation.

**4.C** Linearize data and/or determine a best fit line or curve.

**4.D** Select relevant features of a graph to describe a physical situation or solve problems.

 *Argumentation*

**7.F** Explain how potential sources of experimental error may affect results and/or conclusions.

## TOPIC 3.3

# Electric Circuits: Steady-State Direct-Current Circuits with Batteries and Resistors Only

## Required Course Content

### ENDURING UNDERSTANDING

**CNV-6**

Total energy and charge are conserved in a circuit containing resistors and a source of energy.

### LEARNING OBJECTIVE

**CNV-6.A**

- Identify parallel or series arrangement in a circuit containing multiple resistors.
- Describe a series or a parallel arrangement of resistors.

### ESSENTIAL KNOWLEDGE

**CNV-6.A.1**

Series arrangement of resistors is defined as resistors arranged one after the other, creating one possible branch for charge flow.

**CNV-6.A.2**

Parallel arrangement of resistors is defined as resistors attached to the same two points (electrically), creating multiple pathways for charge flow.

*continued on next page*

## LEARNING OBJECTIVE

**CNV-6.B**

Calculate equivalent resistances for a network of resistors that can be considered a combination of series and parallel arrangements.

**CNV-6.C**

- Calculate voltage, current, and power dissipation for any resistor in a circuit containing a network of known resistors with a single battery or energy source.
- Calculate relationships between the potential difference, current, resistance, and power dissipation for any part of a circuit, given some of the characteristics of the circuit (i.e., battery voltage or current in the battery, or a resistor or branch of resistors).

**CNV-6.D**

Describe a circuit diagram that will properly produce a given current and a given potential difference across a specified component in the circuit.

## ESSENTIAL KNOWLEDGE

**CNV-6.B.1**

The rule for equivalent resistance for resistors arranged in series is:

$$R_s = \sum_i R_i$$

The rule for equivalent resistance for resistors arranged in parallel is:

$$\frac{1}{R_p} = \sum_i \frac{1}{R_i}$$

**CNV-6.C.1**

The current in a circuit containing resistors arranged in series or a branch of a circuit containing resistors arranged in series is the same at every point in the circuit or branch.

- The potential difference is the same value across multiple branches of resistors or branches that are in parallel.
- The reduction of a circuit containing a network of resistors in parallel and series arrangement is necessary to determine the current through the battery.
- Once the current through the battery is known, other quantities can be determined more easily.
- Ohm's Law can be applied for every resistor in the circuit and for every branch in the circuit.

**CNV-6.D.1**

Conventional circuit symbols and circuit-diagramming technique should be used in order to properly represent appropriate circuit characteristics.



## AVAILABLE RESOURCES

Classroom Resources >

- [AP Physics 1 and 2 Lab Manual](#)
- [Conservation Concepts](#)
- [Critical Thinking Concepts in Physics](#)
- [Teaching Strategies for Limited Class Time](#)

*continued on next page*

## LEARNING OBJECTIVE

**CNV-6.E**

- Calculate the terminal voltage and the internal resistance of a battery of specified EMF and known current through the battery.
- Calculate the power distribution of a circuit with a nonideal battery (i.e., power loss due to the battery's resistance versus the total power supplied by the battery).

**CNV-6.F**

- Calculate a single unknown current, potential difference, or resistance in a multi-loop circuit using Kirchhoff's Rules.
- Set up simultaneous equations to calculate at least two unknowns (currents or resistance values) in a multi-loop circuit.
- Explain why Kirchhoff's Rules are valid in terms of energy conservation and charge conservation around a circuit loop.
- Identify when conventional circuit-reduction methods can be used to analyze a circuit and when Kirchhoff's Rules must be used to analyze a circuit.

**CNV-6.G**

- Describe the proper use of an ammeter and a voltmeter in an experimental circuit and correctly demonstrate or identify these methods in a circuit diagram.
- Describe the effect on measurements made by voltmeters or ammeters that have nonideal resistances.

## ESSENTIAL KNOWLEDGE

**CNV-6.E.1**

In a nonideal battery, an internal resistance will exist within the battery. This resistance will add in series to the total external circuit resistance and reduce the operating current in the circuit.

**CNV-6.F.1**

Kirchhoff's Rules allow for the determination of currents and potential differences in complex multi-loop circuits that cannot be reduced using conventional (series/parallel rules) methods.

- According to Kirchhoff's current rule, the current into a junction or node must be equal to the current out of that junction or node. This is a consequence of charge conservation.
- According to Kirchhoff's loop rule, the sum of the potential differences around a closed loop must be equal to zero. This is a consequence of the conservation of energy in a circuit loop.

**CNV-6.G.1**

An ideal ammeter has a resistance that is close to zero (negligible), and an ideal voltmeter has a resistance that is very large (infinite).

- To properly measure current in a circuit branch, an ammeter must be placed in series within the branch. To properly measure potential difference across a circuit element, a voltmeter must be used in a parallel arrangement with the circuit element being measured.

## TOPIC 3.4

# Capacitors in Circuits

### Required Course Content

#### ENDURING UNDERSTANDING

##### CNV-7

Total energy and charge are conserved in a circuit that includes resistors, capacitors, and a source of energy.

#### LEARNING OBJECTIVE

##### CNV-7.A

- Calculate the equivalent capacitance for capacitors arranged in series or parallel, or a combination of both, in steady-state situations.
- Calculate the potential differences across specified capacitors arranged in a series in a circuit.
- Calculate the stored charge in a system of capacitors and on individual capacitors arranged in series or in parallel.

#### ESSENTIAL KNOWLEDGE

##### CNV-7.A.1

The equivalent capacitance of capacitors arranged in series can be determined by the following relationship:

$$\frac{1}{C_s} = \sum_i \frac{1}{C_i}$$

- The equivalent capacitance of capacitors arranged in parallel can be determined by the following relationship:

$$C_p = \sum_i C_i$$

- The system of capacitors will behave as if the one equivalent capacitance were connected to the voltage source.
- For capacitors arranged in parallel, the total charge stored in the system is equivalent to the sum of the individual stored charges on each capacitor.
- For capacitors arranged in series, the total stored charge in the system is  $Q_T$ , and each individual capacitor also has a charge value of  $Q_T$ .

*continued on next page*

#### SUGGESTED SKILLS

 *Visual Representations*

**1.A** Describe the physical meaning (includes identifying features) of a representation.

**1.D** Select relevant features of a representation to answer a question or solve a problem.

 *Question and Method*

**2.D** Make observations or collect data from representations of laboratory setups or results.

 *Representing Data and Phenomena*

**3.C** Sketch a graph that shows a functional relationship between two quantities.

**3.D** Create appropriate diagrams to represent physical situations.

 *Mathematical Routines*

**6.C** Calculate an unknown quantity with units from known quantities, by selecting and following a logical computational pathway.

 *Argumentation*

**7.B** Support a claim with evidence from experimental data.



#### AVAILABLE RESOURCES

Classroom Resources >

- [AP Physics 1 and 2 Lab Manual](#)
- [Conservation Concepts](#)
- [Critical Thinking Concepts in Physics](#)
- [Teaching Strategies for Limited Class Time](#)

## LEARNING OBJECTIVE

**CNV-7.B**

- Calculate the potential difference across a capacitor in a circuit arrangement containing capacitors, resistors, and an energy source under steady-state conditions.
- Calculate the stored charge on a capacitor in a circuit arrangement containing capacitors, resistors, and an energy source under steady-state conditions.

**CNV-7.C**

In transient circuit conditions (i.e., RC circuits), calculate the time constant of a circuit containing resistors and capacitors arranged in series.

**CNV-7.D**

- Derive expressions using calculus to describe the time dependence of the stored charge or potential difference across the capacitor, or the current or potential difference across the resistor in an RC circuit when charging or discharging a capacitor.
- Recognize the model of charging or discharging a capacitor in an RC circuit, and apply the model to a new RC circuit.

## ESSENTIAL KNOWLEDGE

**CNV-7.B.1**

When a circuit containing resistors and capacitors reaches a steady-state condition, the potential difference across the capacitor can be determined using Kirchhoff's Rules.

**CNV-7.C.1**

Under transient conditions for  $t = 0$  to  $t = \text{steady-state conditions}$ , the time constant in an RC circuit is equal to the product of equivalent resistance and the equivalent capacitance.

**CNV-7.D.1**

The changes in the electrical characteristics of a capacitor or resistor in an RC circuit can be described by fundamental differential equations that can be integrated over the transient time interval.

- The general model for the charging or discharging of a capacitor in an RC circuit contains a factor of  $e^{-\frac{t}{RC}}$ .

*continued on next page*

**LEARNING OBJECTIVE****CNV-7.E**

- Describe stored charge or potential difference across a capacitor or current, or potential difference of a resistor in a transient RC circuit.
- Describe the behavior of the voltage or current behavior over time for a circuit that contains resistors and capacitors in a multi-loop arrangement.

**CNV-7.F**

Calculate expressions that determine electrical potential energy stored in a capacitor as a function of time in a transient RC circuit.

**CNV-7.G**

- Describe the energy transfer in charging or discharging a capacitor in an RC circuit.
- Calculate expressions that account for the energy transfer in charging or discharging a capacitor.

**ESSENTIAL KNOWLEDGE****CNV-7.E.1**

The time constant ( $\tau = RC$ ) is a significant feature on the sketches for transient behavior in an RC circuit.

- These particular sketches will always have the exponential decay factor and will either have an asymptote of zero or an asymptote that signifies some physical final state of the system (e.g., final stored charge).
- The initial conditions of the circuit will be represented on the sketch by the vertical intercept of the graph (e.g., initial current).
- The capacitor in a circuit behaves as a “bare wire” with zero resistance at a time immediately after  $t = 0$  seconds.
- The capacitor in a circuit behaves as an “open circuit” or having an infinite resistance in a condition of time much greater than the time constant of the circuit.

**CNV-7.F.1**

The electrical potential energy stored in a capacitor is defined by the following expression:

$$U_E = \frac{1}{2}C(\Delta V)^2$$

This term will vary in time in accordance with the time dependence of the potential difference.

**CNV-7.G.1**

The total energy provided by the energy source (battery) that is transferred into an RC circuit during the charging process is split between the capacitor and the resistor.

THIS PAGE IS INTENTIONALLY LEFT BLANK.

**AP PHYSICS C: ELECTRICITY  
AND MAGNETISM**

**UNIT 4**

**Magnetic  
Fields**



**17–23%**  
AP EXAM WEIGHTING



**~13/~26**  
CLASS PERIODS

---



The icon consists of a white circle containing a blue square with the letters 'AP' in white. Below the square is a small blue monitor icon with two lines representing a screen.

Remember to go to [AP Classroom](#) to assign students the online **Personal Progress Check** for this unit.

Whether assigned as homework or completed in class, the **Personal Progress Check** provides each student with immediate feedback related to this unit's topic and skills.

### **Personal Progress Check 4**

**Multiple-Choice: ~30 questions**

**Free-Response: 1 question**

# Magnetic Fields



## Developing Understanding

### BIG IDEA 1

#### Force Interactions **INT**

- Why are large-scale, charged-particle accelerators in the shape of a circle?

### BIG IDEA 3

#### Fields **FIE**

- How does a guitar pick up work?
- Why does a current deflect the needle of a compass?

### BIG IDEA 4

#### Conservation **CNV**

- Why does the deflection of a pair of parallel conducting wires depend on the directions of current in the wires?

In previous units, students discovered that the electric field allows charged objects to interact without contact. Unit 4 introduces students to magnetism and how magnetic fields are generated, behave, and relate to electricity. Students will learn how magnetic fields impact motion and interact with other magnetic fields. Laboratory investigations and/or activities should be provided for students to apply both the Biot–Savart Law (using calculations to determine the strength of a magnetic field) and Ampère’s Law (deriving mathematical relationships which relate the magnitude of the magnetic field to current). This knowledge from previous units helps students to make connections between electric fields and magnetic fields as well as between Gauss’s Law and Ampère’s Law.

## Building the Science Practices

**2.F** **5.B** **6.C**

Although earlier units centered on collecting and analyzing data from laboratory investigations, the instructional focus of this unit supports students’ proficiency in predicting and justifying how modifications to an experimental procedure will alter results. Making predictions based on fundamental principles of physics is a critical skill for students to develop. Without this skill, students will be unable to determine whether their experimental results match with expected results.

For success in this unit and on the AP Exam, students should be provided with scaffolded practice in crafting clear, concise calculations and derivations that follow a logical computational pathway. Because AP Readers cannot grade what they cannot see or understand, students must have experience with clearly annotating their calculations and derivations and putting them in a logical, sequential, and readable format.

## Preparing for the AP Exam

Students are expected to apply appropriate laws, definitions, or mathematical relationships to solve problems or derive expressions. For example, students will use force and centripetal force equations on a charged, moving particle to determine the radius of curvature of a charged particle moving through a magnetic field. Students are also expected to calculate an unknown quantity with units from known quantities. For students who struggle with this skill, we recommend they start with known physics formulas and then show, step by step (including numeric substitutions), how a final answer is achieved. Students will also develop logical and coherent arguments by using empirical data and/or physical principles to justify a claim.

## UNIT AT A GLANCE

Enduring Understanding	Topic	Suggested Skills	Class Periods
			~13/~26 CLASS PERIODS
CHG-1	<b>4.1 Magnetic Fields: Forces on Moving Charges in Magnetic Fields</b>	<p><b>2.B</b> Make a claim or predict the results of an experiment.</p> <p><b>3.D</b> Create appropriate diagrams to represent physical situations.</p> <p><b>6.C</b> Calculate an unknown quantity with units from known quantities, by selecting and following a logical computational pathway.</p> <p><b>7.A</b> Make a scientific claim.</p> <p><b>7.C</b> Support a claim with evidence from physical representations.</p> <p><b>7.D</b> Provide reasoning to justify a claim using physical principles or laws.</p>	
FIE-4	<b>4.2 Magnetic Fields: Forces on Current Carrying Wires in Magnetic Fields</b>	<p><b>2.C</b> Identify appropriate experimental procedures (which may include a sketch of a lab setup).</p> <p><b>2.D</b> Make observations or collect data from representations of laboratory setups or results.</p> <p><b>2.F</b> Explain modifications to an experimental procedure that will alter results.</p> <p><b>3.A</b> Select and plot appropriate data.</p> <p><b>6.B</b> Apply an appropriate law, definition, or mathematical relationship to solve a problem.</p> <p><b>7.D</b> Provide reasoning to justify a claim using physical principles or laws.</p> <p><b>7.E</b> Explain the connection between experimental results and larger physical principles, laws, or theories.</p> <p><b>7.F</b> Explain how potential sources of experimental error may affect results and/or conclusions.</p>	

*continued on next page*

UNIT AT A GLANCE *(cont'd)*

Enduring Understanding	Topic	Suggested Skills	Class Periods
FIE-5	4.3 Magnetic Fields: Fields of Long Current-Carrying Wires	<p><b>3.B</b> Represent features of a model or the behavior of a physical system using appropriate graphing techniques, appropriate scale, and units.</p> <p><b>3.C</b> Sketch a graph that shows a functional relationship between two quantities.</p> <p><b>5.E</b> Derive a symbolic expression from known quantities by selecting and following a logical algebraic pathway.</p> <p><b>7.C</b> Support a claim with evidence from physical representations.</p>	~13/~26 CLASS PERIODS
	4.4 Magnetic Fields: Biot-Savart Law and Ampère's Law	<p><b>5.D</b> Determine or estimate the change in a quantity using a mathematical relationship.</p> <p><b>5.E</b> Derive a symbolic expression from known quantities by selecting and following a logical algebraic pathway.</p> <p><b>7.A</b> Make a scientific claim.</p>	
CNV-8	<p>Go to <a href="#">AP Classroom</a> to assign the <b>Personal Progress Check</b> for Unit 4. Review the results in class to identify and address any student misunderstandings.</p>		

## SAMPLE INSTRUCTIONAL ACTIVITIES

The sample activities on this page are optional and are offered to provide possible ways to incorporate instructional approaches into the classroom. Teachers do not need to use these activities or instructional approaches and are free to alter or edit them. The examples below were developed in partnership with teachers from the AP community to share ways that they approach teaching some of the topics in this unit. Please refer to the Instructional Approaches section beginning on p. 107 for more examples of activities and strategies.

Activity	Topic	Suggested Activity
1	4.1	<b>Identify Subtasks</b> Have students research some model of old CRT television. Ask them to find the potential difference through which electrons are accelerated to determine their speed entering the magnetic field region, then the strength of the magnetic field needed to deflect them to different points on the screen.
2	4.2	<b>Identify Subtasks</b> Have students research the current in an east-west traveling high-tension power line and find the length of such a power line near their home. Also have them research the magnetic field strength of Earth, and determine the force the Earth's magnetic field exerts on the wire. Compare to the wire's weight.
3	4.3	<b>Create a Plan</b> Have students use their research of high-tension power lines to determine how far from such a power line a person must stand before the magnetic field created by the power line is equal to that of the Earth. Have them conduct the same research for the distance from a wire to a hair dryer or vacuum cleaner in the home.
4	4.4	<b>Create a Plan</b> Have students research the magnetic field strength of a typical MRI machine, as well as the magnetic field strength of the machine's length and radius. Next, have them determine how that magnetic field can be created with a same-radius, same-length solenoid. Include factors such as length and radius of the wire making the solenoid, its resistance, the current and voltage necessary, and the cost of the wire.
5	4.4	<b>Desktop Experiment</b> Obtain a piece of rectangular aluminum foil about 1 foot wide and 2 feet long. Connect it to a battery and resistance (so current travels the long way) and orient it so that current travels toward magnetic north. A compass on the foil should deflect between 30 and 60 degrees (or adjust the voltage/resistance). Have students use the compass deflection and Ampere's Law to determine the magnetic field of Earth.



### Unit Planning Notes

Use the space below to plan your approach to the unit.

---

---

---

## TOPIC 4.1

# Magnetic Fields: Forces on Moving Charges in Magnetic Fields

## Required Course Content

### ENDURING UNDERSTANDING

#### CHG-1

Charged particles moving through a magnetic field may change the direction of their motion.

### LEARNING OBJECTIVE

#### CHG-1.A

- Calculate the magnitude and direction of the magnetic force of interaction between a moving charged particle of specified charge and velocity moving in a region of a uniform magnetic field.
- Describe the direction of a magnetic field from the information given by a description of the motion or trajectory of a charged particle moving through a uniform magnetic field.
- Describe the conditions that are necessary for a charged particle to experience no magnetic force of interaction between the particle and the magnetic field.

### ESSENTIAL KNOWLEDGE

#### CHG-1.A.1



The magnetic force of interaction between a moving charged particle and a uniform magnetic field is defined by the following expression:

$$\vec{F}_M = q(\vec{v} \times \vec{B})$$

- The direction of the magnetic force is determined by the cross-product or can be determined by the appropriate right-hand rule.
- If the moving charged particle moves in a direction that is parallel to the magnetic-field direction, then the magnetic force of interaction is zero.
- The charged particle must have a velocity to interact with the magnetic field.

*continued on next page*

### SUGGESTED SKILLS

-  *Question and Method*
- 2.B** Make a claim or predict the results of an experiment.
-  *Representing Data and Phenomena*
- 3.D** Create appropriate diagrams to represent physical situations.
-  *Mathematical Routines*
- 6.C** Calculate an unknown quantity with units from known quantities, by selecting and following a logical computational pathway.

-  *Argumentation*

- 7.A** Make a scientific claim.
- 7.C** Support a claim with evidence from physical representations.
- 7.D** Provide reasoning to justify a claim using physical principles or laws.



### AVAILABLE RESOURCES

Classroom Resources >

- [AP Physics 1 and 2 Lab Manual](#)
- [Conservation Concepts](#)
- [Critical Thinking Concepts in Physics](#)
- [Teaching Strategies for Limited Class Time](#)

## LEARNING OBJECTIVE

**CHG-1.B**

Describe the path of different moving charged particles (i.e., of different type of charge or mass) in a uniform magnetic field.

**CHG-1.C**

Derive an expression for the radius of a circular path for a charged particle of specified characteristics moving in a specified magnetic field.

**CHG-1.D**

Explain why the magnetic force acting on a moving charge particle does not work on the moving charged particle.

**CHG-1.E**

Describe the conditions under which a moving charged particle can move through a region of crossed electric and magnetic fields with a constant velocity.

## ESSENTIAL KNOWLEDGE

**CHG-1.B.1**

The direction of the magnetic force is always in a direction perpendicular to the velocity of the moving charged particle. This results in a trajectory that is either a curved path or a complete circular path (if it moves in the field for a long enough time).

**CHG-1.C.1**

The magnetic force is always acting in a perpendicular direction to the moving particle. The result of this is a centripetal force of a constant magnitude and a centripetal acceleration of constant magnitude.

- The radius of the circular path can be determined by applying a Newton's second law analysis for the moving charged particle in the centripetal direction.

**CHG-1.D.1**

The magnetic force is defined as cross-product between the velocity vector and the magnetic-field vector. The result of this is a force that is always perpendicular to the velocity vector.

**CHG-1.E.1**

In a region containing both a magnetic field and an electric field, a moving charged particle will experience two different forces independent from each other. Depending on the physical parameters, it is possible for each force to be equal in magnitude and opposite in direction, thus producing a net force of zero on the moving charged particle.

## TOPIC 4.2

# Magnetic Fields: Forces on Current-Carrying Wires in Magnetic Fields

## Required Course Content

### ENDURING UNDERSTANDING

**FIE-4**

A magnetic field can interact with a straight conducting wire with current.

### LEARNING OBJECTIVE

**FIE-4.A**

- Calculate the magnitude of the magnetic force acting on a straight-line segment of a conductor with current in a uniform magnetic field.
- Describe the direction of the magnetic force of interaction on a segment of a straight current-carrying conductor in a specified uniform magnetic field.

### ESSENTIAL KNOWLEDGE

**FIE-4.A.1**

The definition of the magnetic force acting on a straight-line segment of a current-carrying conductor in a uniform magnetic field is:

$$\vec{F}_M = \int I(d\vec{\ell} \times \vec{B})$$

- The direction of the force can be determined by the cross-product or by the appropriate right-hand rule.

*continued on next page*

### SUGGESTED SKILLS



*Question and Method*

**2.C** Identify appropriate experimental procedures (which may include a sketch of a lab setup).

**2.D** Make observations or collect data from representations of laboratory setups or results.

**2.F** Explain modifications to an experimental procedure that will alter results.



*Representing Data and Phenomena*

**3.A** Select and plot appropriate data.



*Mathematical Routines*

**6.B** Apply an appropriate law, definition, or mathematical relationship to solve a problem.



*Argumentation*

**7.D** Provide reasoning to justify a claim using physical principles or laws.

**7.E** Explain the connection between experimental results and larger physical principles, laws, or theories.

**7.F** Explain how potential sources of experimental error may affect results and/or conclusions.



### AVAILABLE RESOURCES

Classroom Resources >

- [AP Physics 1 and 2 Lab Manual](#)
- [Conservation Concepts](#)
- [Critical Thinking Concepts in Physics](#)
- [Teaching Strategies for Limited Class Time](#)



**LEARNING OBJECTIVE****FIE-4.B**

- Describe or indicate the direction of magnetic forces acting on a complete conductive loop with current in a region of uniform magnetic field.
- Describe the mechanical consequences of the magnetic forces acting on a current-carrying loop of wire.

**FIE-4.C**

Calculate the magnitude and direction of the net torque experienced by a rectangular loop of wire carrying a current in a region of a uniform magnetic field.

**ESSENTIAL KNOWLEDGE****FIE-4.B.1**

A complete conductive loop (rectangular or circular) will experience magnetic forces at all points on the wire. The net direction of all of the forces will result in a net force of zero acting on the center of mass of the loop.

- Depending on the orientation of the loop and the field, the forces may result in a torque that acts on the loop.

**FIE-4.C.1**

The definition of torque can be applied to the loop to determine a relationship between the torque, field, current, and area of the loop.

## TOPIC 4.3

# Magnetic Fields: Fields of Long, Current-Carrying Wires

## Required Course Content

### ENDURING UNDERSTANDING

**FIE-5**

Current-carrying conductors create magnetic fields that allow them to interact at a distance with other magnetic fields.

### LEARNING OBJECTIVE

**FIE-5.A**

- Calculate the magnitude and direction of a magnetic field produced at a point near a long, straight, current-carrying wire.
- Apply the right-hand rule for magnetic field of a straight wire (or correctly use the Biot-Savart Law found in CNV-8.A.1) to deduce the direction of a magnetic field near a long, straight, current-carrying wire.

### ESSENTIAL KNOWLEDGE

**FIE-5.A.1**

It can be shown or experimentally verified that the magnetic field of a long, straight, current-carrying conductor is:

$$B = \frac{\mu_0 I}{2\pi r}$$

- The magnitude of the field is proportional to the inverse of distance from the wire.
- The magnetic-field vector is always mutually perpendicular to the position vector and the direction of the conventional current. The result of this is a magnetic field line that is in a circular path around the wire in a sense (clockwise or counterclockwise) determined by the appropriate right-hand rule.
- The magnetic field inside a solenoid can be determined using:

$$B = \mu_0 nI$$

*continued on next page*

### SUGGESTED SKILLS

 *Representing Data and Phenomena*

**3.B** Represent features of a model or the behavior of a physical system using appropriate graphing techniques, appropriate scale, and units.

**3.C** Sketch a graph that shows a functional relationship between two quantities.

 *Theoretical Relationships*

**5.E** Derive a symbolic expression from known quantities by selecting and following a logical algebraic pathway.

 *Argumentation*

**7.C** Support a claim with evidence from physical representations.



### AVAILABLE RESOURCES

Classroom Resources >

- [AP Physics 1 and 2 Lab Manual](#)
- [Conservation Concepts](#)
- [Critical Thinking Concepts in Physics](#)
- [Teaching Strategies for Limited Class Time](#)

**LEARNING OBJECTIVE****FIE-5.B**

- Describe the direction of a magnetic-field vector at various points near multiple long, straight, current-carrying wires.
- Calculate the magnitude of a magnetic field at various points near multiple long, straight, current-carrying wires.
- Calculate an unknown current value or position value, given a specified magnetic field at a point due to multiple long, straight, current-carrying wires.

**FIE-5.C**

- Calculate the force of attraction or repulsion between two long, straight, current-carrying wires.
- Describe the consequence (attract or repel) when two long, straight, current-carrying wires have known current directions.

**ESSENTIAL KNOWLEDGE****FIE-5.B.1**

The principle of superposition can be used to determine the net magnetic field at a point due to multiple long, straight, current-carrying wires.

**FIE-5.C.1**

The field of a long, straight wire can be used as the external field in the definition of magnetic force acting on a segment of current carrying wire.

- The direction of the force can be determined from the cross-product definition or from the appropriate right-hand rule.

## TOPIC 4.4

# Magnetic Fields: Biot–Savart Law and Ampère’s Law

### Required Course Content

#### ENDURING UNDERSTANDING

##### CNV-8

There are laws that use symmetry and calculus to derive mathematical relationships that are applied to physical systems containing moving charge.

#### LEARNING OBJECTIVE

##### CNV-8.A

- Describe the direction of the contribution to the magnetic field made by a short (differential) length of straight segment of a current-carrying conductor.
- Calculate the magnitude of the contribution to the magnetic field due to a short (differential) length of straight segment of a current-carrying conductor.

#### ESSENTIAL KNOWLEDGE

##### CNV-8.A.1

The Biot–Savart Law is the fundamental law of magnetism that defines the magnitude and direction of a magnetic field due to moving charges or current-carrying conductors. The law in differential form is:

$$d\vec{B} = \frac{\mu_0}{4\pi} I \frac{d\vec{\ell} \times \hat{r}}{r^2}$$

*continued on next page*

#### SUGGESTED SKILLS

 *Theoretical Relationships*

**5.D** Determine or estimate the change in a quantity using a mathematical relationship.

**5.E** Derive a symbolic expression from known quantities by selecting and following a logical algebraic pathway.

 *Argumentation*

**7.A** Make a scientific claim.



#### AVAILABLE RESOURCES

Classroom Resources >

- [AP Physics 1 and 2 Lab Manual](#)
- [Conservation Concepts](#)
- [Critical Thinking Concepts in Physics](#)
- [Teaching Strategies for Limited Class Time](#)

## LEARNING OBJECTIVE

## CNV-8.B

- Derive the expression for the magnitude of magnetic field on the axis of a circular loop of current or a segment of a circular loop.
- Explain how the Biot–Savart Law can be used to determine the field of a long, straight, current-carrying wire at perpendicular distances close to the wire.

## CNV-8.C

- Explain Ampère’s Law and justify the use of the appropriate Amperian loop for current-carrying conductors of different shapes such as straight wires, closed circular loops, conductive slabs, or solenoids.
- Derive the magnitude of the magnetic field for certain current-carrying conductors using Ampère’s law and symmetry arguments.
- Derive the expression for the magnetic field of an ideal solenoid (length dimension is much larger than the radius of the solenoid) using Ampère’s Law.
- Describe the conclusions that can be made about the magnetic field at a particular point in space if the line integral in Ampère’s Law is equivalent to zero.

## ESSENTIAL KNOWLEDGE

## CNV-8.B.1

The Biot–Savart Law can be used to derive the magnitude and directions of magnetic fields of symmetric current-carrying conductors (e.g., circular loops), long, straight conductors, or segments of loops.

## CNV-8.C.1

Ampère’s Law is a fundamental law of magnetism that relates the magnitude of the magnetic field to the current enclosed by a closed imaginary path called an Amperian loop. The law in integral form is:

$$\oint \vec{B} \cdot d\vec{\ell} = \mu_0 I$$

where  $I$  in this case is the enclosed current by the Amperian loop.

- Ampère’s Law for magnetism is analogous to Gauss’s Law for electrostatics and is a fundamental law that allows for an easier approach to determining some magnetic fields of certain symmetries or shapes of current-carrying conductors. The law is always true but not always useful.
- The law can only be applied when the symmetry of the magnetic field can be exploited. Circular loops; long, straight wires; conductive slabs with current density; solenoids; and other cylindrical conductors containing current are the types of shapes for which Ampère’s Law can be useful.

*continued on next page*

## LEARNING OBJECTIVE

### CNV-8.D

Describe the relationship of the magnetic field as a function of distance for various configurations of current-carrying cylindrical conductors with either a single current or multiple currents, at points inside and outside of the conductors.

### CNV-8.E

- Describe the direction of a magnetic field at a point in space due to various combinations of conductors, wires, cylindrical conductors, or loops.
- Calculate the magnitude of a magnetic field at a point in space due to various combinations of conductors, wires, cylindrical conductors, or loops.

## ESSENTIAL KNOWLEDGE

### CNV-8.D.1

Ampère's Law can be used to determine magnetic-field relationships at different locations in cylindrical current-carrying conductors.

### CNV-8.E.1

The principle of superposition can be used to determine the net magnetic field at a point in space due to various combinations of current-carrying conductors, loops, segments, or cylindrical conductors. Ampère's Law can be used to determine individual field magnitudes. The principle of superposition can be used to add those individual fields.

THIS PAGE IS INTENTIONALLY LEFT BLANK.

## AP PHYSICS C: ELECTRICITY AND MAGNETISM

# UNIT 5

# Electromagnetism



**14–20%**  
AP EXAM WEIGHTING



**~10/~20**  
CLASS PERIODS

---



The icon consists of a white circle containing a blue square with the letters 'AP' in white. Below the square is a small blue monitor icon with two vertical lines representing a stand.

Remember to go to [AP Classroom](#) to assign students the online **Personal Progress Check** for this unit.

Whether assigned as homework or completed in class, the **Personal Progress Check** provides each student with immediate feedback related to this unit's topic and skills.

### **Personal Progress Check 5**

**Multiple-Choice: ~25 questions**

**Free-Response: 1 question**

# Electromagnetism



## Developing Understanding

### BIG IDEA 2

#### Force Interactions **ACT**

- How does an electric motor work?

### BIG IDEA 3

#### Fields **FIE**

- How does pushing the button at the door produce a sound inside the house?
- How does an antenna work?

### BIG IDEA 4

#### Conservation **CNV**

- How does the digital recording in your MP3 player generate sound waves in your headphones?
- How does Wi-Fi work?

Throughout the course, students explored the vital roles electricity and magnetism play in our daily lives. Unit 5 examines electromagnetism through the concept of electromagnetic induction and the application of Maxwell's equations. Through activities and detailed laboratory investigations, students will study, apply, and analyze the concept of induction, as well as investigate the relationship between Faraday's Law and Lenz's Law. Additionally, students are expected to call upon their knowledge obtained in earlier units—particularly that of charges, currents, and electric and magnetic fields—to better understand Maxwell's equations and to be able to mathematically demonstrate, as well as reason with, how these fields are generated.

## Building the Science Practices

4.E 5.E 7.D

In Unit 5, students are not only required to create and use representations (including graphs, equations, and tables of data), but must also be able to explain how the representation illustrates a physical principle, process, concept, or theory. Students will be expected to use representations, as well as data and/or fundamental laws of physics, to provide reasoning to justify a claim. By the end of Unit 5, students should be proficient in calculating unknown quantities with unit and/or symbolic expressions from known quantities by selecting and following a logical computational pathway. As in Unit 4, merely solving for a final answer is insufficient; students require practice crafting clear, concise, arguments, derivations, and calculations that follow a logical pathway.

## Preparing for the AP Exam

Students will need to determine the relationships between variables and models to describe a physical situation. For example, students may be asked to determine the changes in an induced current when the magnetic flux through the loop is changing or if the magnetic field is turned on and off.

On the exam, students are also expected to make a claim or prediction based on scientific reasoning, such as using Lenz's Law to infer the direction of an induced current in a loop. Students often struggle with the direction of the magnetic field, believing that if the magnetic field points into the loop, the loop will induce a magnetic field in the opposite direction. However, if Lenz's Law is correctly applied, students will understand that it relates to changing magnetic flux (i.e., the induced field opposes the change in magnetic flux, not the direction of the magnetic field itself).

## UNIT AT A GLANCE

Enduring Understanding	Topic	Suggested Skills	Class Periods
			~10/~20 CLASS PERIODS
CNV-9, FIE-6, ACT-4	<b>5.1 Electromagnetism: Electromagnetic Induction (Including Faraday’s Law and Lenz’s Law)</b>	<p><b>1.D</b> Select relevant features of a representation to answer a question or solve a problem.</p> <p><b>1.E</b> Describe the effects of modifying conditions or features of a representation of a physical situation.</p> <p><b>6.D</b> Assess the reasonableness of results or solutions.</p> <p><b>7.A</b> Make a scientific claim.</p> <p><b>7.E</b> Explain the connection between experimental results and larger physical principles, laws, or theories.</p>	
CNV-10	<b>5.2 Electromagnetism: Inductance (Including LR Circuits)</b>	<p><b>5.A</b> Select an appropriate law, definition, mathematical relationship, or model to describe a physical situation.</p> <p><b>6.B</b> Apply an appropriate law, definition, or mathematical relationship to solve a problem.</p> <p><b>6.C</b> Calculate an unknown quantity with units from known quantities, by selecting and following a logical computational pathway.</p> <p><b>7.D</b> Provide reasoning to justify a claim using physical principles or laws.</p>	
FIE-7	<b>5.3 Electromagnetism: Maxwell’s Equations</b>	<p><b>1.E</b> Describe the effects of modifying conditions or features of a representation of a physical situation.</p> <p><b>4.C</b> Linearize data and/or determine a best fit line or curve.</p> <p><b>4.E</b> Explain how the data or graph illustrates a physics principle, process, concept, or theory.</p> <p><b>5.E</b> Derive a symbolic expression from known quantities by selecting and following a logical algebraic pathway.</p> <p><b>7.D</b> Provide reasoning to justify a claim using physical principles or laws.</p>	
<p> Go to <a href="#">AP Classroom</a> to assign the <b>Personal Progress Check</b> for Unit 5. Review the results in class to identify and address any student misunderstandings.</p>			

## SAMPLE INSTRUCTIONAL ACTIVITIES

The sample activities on this page are optional and are offered to provide possible ways to incorporate instructional approaches into the classroom. Teachers do not need to use these activities or instructional approaches and are free to alter or edit them. The examples below were developed in partnership with teachers from the AP community to share ways that they approach teaching some of the topics in this unit. Please refer to the Instructional Approaches section beginning on p. 107 for more examples of activities and strategies.

Activity	Topic	Suggested Activity
1	5.1	<b>Desktop Experiment</b> Have students spin a magnet within a coil of wire and measure the spin rate, area, number of coils, and peak voltage induced. From this, have students estimate the strength of the magnetic field generated by the magnet.
2	5.1	<b>Qualitative Reasoning</b> Have students explain qualitatively how electromagnetic braking works, including how electromagnetic brakes are structured, how e-brakes can recharge a battery, and how e-brakes can double as electric motors.
3	5.2	<b>Desktop Experiment</b> Have students construct their own solenoid (or provide one) and measure its inductance using an RL circuit (measure the time constant and the R to get L). Have them repeat the experiment with iron or steel in the core of the inductor to get the increased L.
4	5.2	<b>Graph and Switch</b> Have Student A construct quantitative graphs of current versus time and voltage versus time for Inductor, Resistor 1, and Resistor 2 that shows current/voltage before and after a switch opens/closes. Student B must then construct the circuit with the switch, R1, R2, L.
5	5.3	<b>Construct an Argument</b> Have students use Maxwell's equations to construct arguments for the following: Why there can be no magnetic monopoles, what eddy currents are and why they exist, why a surface entirely within conducting material must have zero net charge within, and why there must be electric currents within the Earth's core.



### Unit Planning Notes

Use the space below to plan your approach to the unit.

.....

.....

.....

## SUGGESTED SKILLS

 *Visual Representations*

**1.D** Select relevant features of a representation to answer a question or solve a problem.

**1.E** Describe the effects of modifying conditions or features of a representation of a physical situation.

 *Mathematical Routines*

**6.D** Assess the reasonableness of results or solutions.

 *Argumentation*

**7.A** Make a scientific claim.

**7.E** Explain the connection between experimental results and larger physical principles, laws, or theories.



## AVAILABLE RESOURCES

Classroom Resources >

- [AP Physics 1 and 2 Lab Manual](#)
- [Conservation Concepts](#)
- [Critical Thinking Concepts in Physics](#)
- [Teaching Strategies for Limited Class Time](#)

## TOPIC 5.1

# Electromagnetism: Electromagnetic Induction (Including Faraday's Law and Lenz's Law)

## Required Course Content

### ENDURING UNDERSTANDING

#### CNV-9

There are laws that use symmetry and calculus to derive mathematical relationships that are applied to physical systems containing a magnetic field.

### LEARNING OBJECTIVE

#### CNV-9.A

- a. Calculate the magnetic flux through a loop of regular shape with an arbitrary orientation in relation to the magnetic-field direction.
- b. Calculate the magnetic flux of the field due to a current-carrying, long, straight wire through a rectangular-shaped area that is in the plane of the wire and oriented perpendicularly to the field.
- c. Calculate the magnetic flux of a non-uniform magnetic field that may have a magnitude that varies over one coordinate through a specified rectangular loop that is oriented perpendicularly to the field.

### ESSENTIAL KNOWLEDGE

#### CNV-9.A.1

Magnetic flux is the scalar product of the magnetic-field vector and the area vector over the entire area contained by the loop. The definition of magnetic flux is:

$$\Phi_B = \int \vec{B} \cdot d\vec{A}$$

## ENDURING UNDERSTANDING

## FIE-6

A changing magnetic field over time can induce current in conductors.

## LEARNING OBJECTIVE

## FIE-6.A

- Describe which physical situations with a changing magnetic field and a conductive loop will create an induced current in the loop.
- Describe the direction of an induced current in a conductive loop that is placed in a changing magnetic field.
- Describe the induced current magnitudes and directions for a conductive loop moving through a specified region of space containing a uniform magnetic field.
- Calculate the magnitude and direction of induced EMF and induced current in a conductive loop (or conductive bar) when the magnitude of either the field or area of loop is changing at a constant rate.
- Calculate the magnitude and direction of induced EMF and induced current in a conductive loop (or conductive bar) when a physical quantity related to magnetic field or area is changing with a specified non-linear function of time.
- Derive expressions for the induced EMF (or current) through a closed conductive loop with a time-varying magnetic field directed either perpendicularly through the loop or at some angle oriented relative to the magnetic-field direction.
- Describe the relative magnitude and direction of induced currents in a conductive loop with a time-varying magnetic field.

## ESSENTIAL KNOWLEDGE

## FIE-6.A.1

Induced currents arise in a conductive loop (or long wire) when there is a change in magnetic flux occurring through the loop. This change is defined by Faraday's Law:

$$\mathcal{E}_i = -N \frac{d\phi_B}{dt}$$

where  $\mathcal{E}_i$  is the induced EMF and  $N$  is number of turns. (In a coil or solenoid, the  $N$  refers to the number of turns of coil or conductive loops in the solenoid.)

- The negative sign in the expression embodies Lenz's Law and is an important part of the relationship.
- Lenz's Law is the relationship that allows the direction of the induced current to be determined. The law states that any induced EMF and current induced in a conductive loop will create an induced current and induced magnetic field to oppose the direction change in external flux.
- Lenz's Law is essentially a law relating to conservation of energy in a system and has mechanical consequences.

**ENDURING UNDERSTANDING****ACT-4**

Induced forces (arising from magnetic interactions) that are exerted on objects can change the kinetic energy of an object.

**LEARNING OBJECTIVE****ACT-4.A**

- Determine if a net force or net torque exists on a conductive loop in a region of changing magnetic field.
- Justify if a conductive loop will change its speed as it moves through different regions of a uniform magnetic field.

**ACT-4.B**

- Calculate an expression for the net force on a conductive bar as it is moved through a magnetic field.
- Write a differential equation and calculate the terminal velocity for the motion of a conductive bar (in a closed electrical loop) falling through a magnetic field or moving through a field due to other physical mechanisms.
- Describe the mechanical consequences of changing an electrical property (such as resistance) or a mechanical property (such as length/area) of a conductive loop as it moves through a uniform magnetic field.
- Derive an expression for the mechanical power delivered to a conductive loop as it moves through a magnetic field in terms of the electrical characteristics of the conductive loop.

**ESSENTIAL KNOWLEDGE****ACT-4.A.1**

When an induced current is created in a conductive loop, the current will interact with the already-present magnetic field, creating induced forces acting on the loop. The magnitude and directions of these induced forces can be calculated using the definition of force on a current-carrying wire.

**ACT-4.B.1**

Newton's second law can be applied to a moving conductor as it experiences a flux change.

- The force on the conductor is proportional to the velocity of the conductor.
- A differential equation of velocity can be written for these physical situations.
- This will lead to an exponential relationship with the changing velocity of the conductor.
- Using calculus, the expressions for velocity, induced force, and power can all be expressed with these exponential relationships.

## TOPIC 5.2

# Electromagnetism: Inductance (Including LR circuits)

## Required Course Content

### ENDURING UNDERSTANDING

#### CNV-10

In a closed circuit containing inductors and resistors, energy and charge are conserved.

### LEARNING OBJECTIVE

#### CNV-10.A

- Derive the expression for the inductance of a long solenoid.
- Calculate the magnitude and the sense of the EMF in an inductor through which a changing current is specified.
- Calculate the rate of change of current in an inductor with a transient current.

#### CNV-10.B

Calculate the stored electrical energy in an inductor that has a steady-state current.

### ESSENTIAL KNOWLEDGE

#### CNV-10.A.1

By applying Faraday's Law to an inductive electrical device, a variation on the law can be determined to relate the definition of inductance to the properties of the inductor:

$$\varepsilon_i = -L \frac{dI}{dt}$$

where  $L$  is defined as the inductance of the electrical device.

- The very nature of the inductor is to oppose the change in current occurring in the inductor.

#### CNV-10.B.1

The stored energy in an inductor is defined by:

$$U_L = \frac{1}{2}LI^2$$

### SUGGESTED SKILLS

 *Theoretical Relationships*

**5.A** Select an appropriate law, definition, mathematical relationship, or model to describe a physical situation.

 *Mathematical Routines*

**6.B** Apply an appropriate law, definition, or mathematical relationship to solve a problem.

**6.C** Calculate an unknown quantity with units from known quantities, by selecting and following a logical computational pathway.

 *Argumentation*

**7.D** Provide reasoning to justify a claim using physical principles or laws.



### AVAILABLE RESOURCES

Classroom Resources >

- [AP Physics 1 and 2 Lab Manual](#)
- [Conservation Concepts](#)
- [Critical Thinking Concepts in Physics](#)
- [Teaching Strategies for Limited Class Time](#)

*continued on next page*



**LEARNING OBJECTIVE****CNV-10.C**

- Calculate initial transient currents and final steady-state currents through any part of a series or parallel circuit containing an inductor and one or more resistors.
- Calculate the maximum current in a circuit that contains only a charged capacitor and an inductor.

**CNV-10.D**

- Derive a differential equation for the current as a function of time in a simple LR series circuit.
- Derive a solution to the differential equation for the current through the circuit as a function of time in the cases involving the simple LR series circuit.

**CNV-10.E**

Describe currents or potential differences with respect to time across resistors or inductors in a simple circuit containing resistors and an inductor, either in series or a parallel arrangement.

**ESSENTIAL KNOWLEDGE****CNV-10.C.1**

The electrical characteristics of an inductor in a circuit are the following:

- At the initial condition of closing or opening a switch with an inductor in a circuit, the induced voltage will be equal in magnitude and opposite in direction of the applied voltage across the branch containing the inductor.
- In a steady-state condition, the ideal inductor has a resistance of zero and therefore will behave as a bare wire in a circuit.
- In circuits containing only a charged capacitor and an inductor, the maximum current through the inductor can be determined by applying conservation of energy within the circuit and the two circuit elements that can store energy.

**CNV-10.D.1**

Kirchhoff's Rules can be applied to a series LR circuit. The result of applying Kirchhoff's rules in this case will be a differential equation in current for the loop.

- The solution of this equation will yield the fundamental models for the LR circuit (in turning on the circuit and turning off the circuit).

**CNV-10.E.1**

Using Kirchhoff's Rules and the general model for an LR circuit, general current characteristics can be determined in an LR circuit in a series or parallel arrangement.

## TOPIC 5.3

# Electromagnetism: Maxwell's Equations

## Required Course Content

### ENDURING UNDERSTANDING

**FIE-7**

Electric and magnetic fields that change over time can mutually induce other electric and magnetic fields.

### LEARNING OBJECTIVE

**FIE-7.A**

- Explain how a changing magnetic field can induce an electric field.
- Associate the appropriate Maxwell's equation with the appropriate physical consequence in a physical system containing a magnetic or electric field.

### ESSENTIAL KNOWLEDGE

**FIE-7.A.1**

Maxwell's Laws completely describe the fundamental relationships of magnetic and electric fields in steady-state conditions, as well as in situations in which the fields change in time.

### SUGGESTED SKILLS

 *Visual Representations*

**1.E** Describe the effects of modifying conditions or features of a representation of a physical situation.

 *Data Analysis*

**4.C** Linearize data and/or determine a best fit line or curve.

**4.E** Explain how the data or graph illustrates a physics principle, process, concept, or theory.

 *Theoretical Relationships*

**5.E** Derive a symbolic expression from known quantities by selecting and following a logical algebraic pathway.

 *Argumentation*

**7.D** Provide reasoning to justify a claim using physical principles or laws.



### AVAILABLE RESOURCES

Classroom Resources >

- [AP Physics 1 and 2 Lab Manual](#)
- [Conservation Concepts](#)
- [Critical Thinking Concepts in Physics](#)
- [Teaching Strategies for Limited Class Time](#)

THIS PAGE IS INTENTIONALLY LEFT BLANK.

**AP PHYSICS C: ELECTRICITY AND MAGNETISM**

---

# Laboratory Investigations

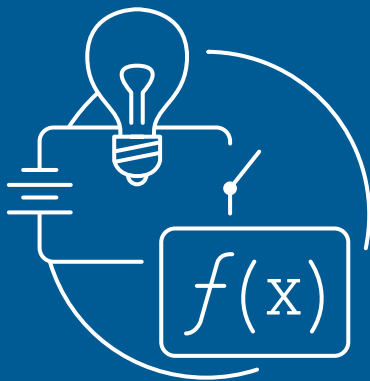

# Lab Experiments

---

Although laboratory work has often been separated from classroom work, research shows that experience and experiment are often more instructionally effective when flexibly integrated into the development of concepts. When students build their own conceptual understanding of the principles of physics, their familiarity with the concrete evidence for their ideas leads to deeper understanding and gives them a sense of ownership of the knowledge they have constructed.

Scientific inquiry experiences in AP Physics C: Electricity and Magnetism should be designed and implemented with increasing student involvement to help enhance inquiry learning and the development of critical thinking and problem-solving skills and abilities. Typically, the level of investigations in an AP Physics C: Electricity and Magnetism classroom should focus primarily on the continuum between guided and open inquiry. However, depending on students' familiarity with a topic, a given laboratory experience might incorporate a sequence involving all four levels of inquiry (confirmation, structured inquiry, guided inquiry, and open inquiry).

## Lab Manuals and Lab Notebooks

College Board publishes [AP Physics 1 and 2 Inquiry-Based Lab Investigations: A Teachers Manual](#) to support the guided inquiry lab requirement for the course. It includes labs that teachers can choose from to satisfy the guided inquiry lab component for the course. Many publishers and science classroom material distributors offer affordable lab manuals with outlined experiments and activities as well as lab notebooks for recording lab data and observations. Students can use any type of notebook to fulfill the lab notebook requirement, even an online document. Consider the needs of the classroom when deciding what type of lab notebook to use.

## Lab Materials

A wide range of equipment may be used in the physics laboratory, from generic lab items, such as metersticks, rubber balls, springs, string, metal spheres, calibrated mass sets, beakers, glass and cardboard tubes, electronic balances, stopwatches, clamps, and ring stands, to items more specific to physics, such as tracks, carts, light bulbs, resistors, magnets, and batteries. Successful guided inquiry student work can be accomplished with both simple,

inexpensive materials and with more sophisticated physics equipment, such as air tracks, force sensors, and oscilloscopes. Remember that the AP lab should provide experience for students equivalent to that of a college laboratory, so teachers are encouraged to make every effort to provide a range of experiences—from experiments students contrive from plumbing pipe, string, and duct tape to experiments in which students gather and analyze data using calculators or computer-interfaced equipment.

There are avenues that teachers can explore as a means of getting access to more expensive equipment, such as computers and probes. Probes can often be rented for short periods of time from instrument suppliers. Alternatively, local colleges or universities may allow high school students to complete a lab as a field trip on their campus, or they may allow teachers to borrow their equipment. They may even donate their old equipment. Some schools have partnerships with local businesses that can help with laboratory equipment and materials. Teachers can also utilize online donation sites such as Donors Choose and Adopt-A-Classroom.

## Lab Time

For AP Physics C: Electricity and Magnetism to be comparable to a college physics course, it is critical that teachers make laboratory work an important part of their curriculum. An analysis of data from AP Physics examinees, regarding the length of time they spent per week in the laboratory, shows that increased laboratory time correlates with higher AP scores. Flexible or modular scheduling must be implemented to meet the time requirements identified in the course outline. At minimum, one double period a week is needed. Furthermore, it is important that the AP Physics laboratory program be adapted to local conditions and funding as it aims to offer the students a well-rounded experience with experimental physics. Adequate laboratory facilities should be provided so that each student has a work space where equipment and materials can be left overnight if necessary. Sufficient laboratory equipment for the anticipated enrollment and appropriate instruments should be provided. Students in AP Physics should have access to computers with software appropriate for processing laboratory data and writing reports.

# How to Set Up a Lab Program

---

Physics is not just a subject. Rather, it is a way of approaching scientific discovery that requires personal observation and physical experimentation. Being successful in this endeavor requires students to synthesize and use a broad spectrum of knowledge and skills, including mathematical, computational, experimental, and practical skills, and to develop habits of mind that might be characterized as thinking like a physicist. Student-directed, inquiry-based lab experience supports the AP Physics C: Electricity and Magnetism course and AP Course Audit curricular requirements. It provides opportunities for students to design experiments, collect data, apply mathematical routines and methods, and refine testable explanations and predictions. Each AP Physics C: Electricity and Magnetism course should include a hands-on laboratory component comparable to a semester-long, introductory, college-level physics laboratory. Students should spend a minimum of 25% of instructional time engaged in hands-on laboratory work.

The AP Physics C: Electricity and Magnetism Exam directly assesses the learning objectives of the course framework, which means that the inclusion of appropriate experiments aligned with those learning objectives is important for student success. Teachers should select experiments that provide students with the broadest laboratory experience possible.

We encourage teachers to be creative in designing their lab program while ensuring that students explore and develop understandings of these core techniques. After completion, students should be able to describe how to construct knowledge, model (create an abstract representation of a real system), design experiments, analyze visual data, and communicate physics. Students should also develop an understanding of how changes in the design of the experiments would affect the outcome of their results. Many questions on the AP Exam are written in an experimental context, so these skills will prove invaluable for both concept comprehension and exam performance.

Because AP Physics C: Electricity and Magnetism is equivalent to a college course, the equipment and time allotted to laboratories should be similar to that in a college course. Therefore, school administrators should realize the implications, in both cost and

time, of incorporating serious laboratories into their program. Schools must ensure that students have access to scientific equipment and all materials necessary to conduct hands-on, college-level physics laboratory investigations.

## Getting Students Started

There are no prescriptive “steps” to the iterative process of inquiry-based investigations. However, there are some common characteristics of inquiry that will support students in designing their investigations. Often, this simply begins with using the learning objectives to craft a question for students to investigate. Teachers may choose to give students a list of materials they are allowed to use in their design or require that students request the equipment they feel they need to investigate the question. Working with learning objectives to craft questions may include:

- Selecting learning objectives from the course framework that relate to the subject under study, and that may set forth specific tasks, in the form of “Design an experiment to \_\_\_\_\_”.
- Rephrasing or refining the learning objectives that align to the unit of study to create an inquiry-based investigation for students.

Students should be given latitude to make design modifications or ask for additional equipment appropriate for their design. It is also helpful for individual groups to report to the class their basic design to elicit feedback on feasibility. Guided student groups can proceed through the experiment, with the teacher allowing them the freedom to make mistakes—as long as those mistakes don’t endanger students or equipment or lead the groups too far off task. Students should have many opportunities for post-lab reporting so that groups can understand the successes and challenges of individual lab designs.

## Communication, Group Collaboration, and the Laboratory Record

Laboratory work is an excellent means through which students can develop and practice communication skills. Success in subsequent work in physics depends heavily on an ability to communicate about observations, ideas, and conclusions. Students must learn to recognize that an understanding of physics is relatively useless unless they can communicate their knowledge effectively to others. By working together in a truly collaborative manner to plan and carry out experiments, students learn oral communication skills and teamwork. Students must be encouraged to take full individual responsibility for the success, or failure, of the collaboration.

After students are given a question for investigation, they may present their findings in either a written or oral report to the teacher and class for feedback and critique on their final design and results. Students should be encouraged to critique and challenge one another's claims based on the evidence collected during the investigation.

## Laboratory Safety

Giving students the responsibility for design of their own laboratory experience involves special responsibilities for teachers. To ensure a safe working environment, teachers should first provide the limitations and safety precautions necessary for potential procedures and equipment students may use during their investigation. Teachers should also

provide specific guidelines prior to students' discussion on investigation designs for each experiment, so that those precautions can be incorporated into final student-selected lab designs and included in the background or design plan in a laboratory record. It may also be helpful to print the precautions that apply to that specific lab as Safety Notes to place on the desk or wall near student workstations. Additionally, a general set of safety guidelines should be set forth for students at the beginning of the course. The following is a list of possible general guidelines teachers may post:

- Before each lab, make sure you know and record the potential hazards involved in the investigation, as well as the precautions you will take to stay safe.
- Before using equipment, make sure you know the proper method of use to acquire good data and avoid damage to equipment.
- Know where safety equipment is located in the lab, such as the fire extinguisher, safety goggles, and the first aid kit.
- Follow the teacher's special safety guidelines as set forth prior to each experiment. (Students should record these as part of their design plan for a lab.)
- When in doubt about the safety or advisability of a procedure, check with the teacher before proceeding.

Teachers should interact constantly with students as they work to observe safety practices and anticipate and discuss with them any problems that may arise. Walking among student groups, asking questions, and showing interest in students' work allows teachers to keep the pulse of what students are doing and maintain a watchful eye for potential safety issues.



THIS PAGE IS INTENTIONALLY LEFT BLANK.

**AP PHYSICS C: ELECTRICITY AND MAGNETISM**

---

# Instructional Approaches

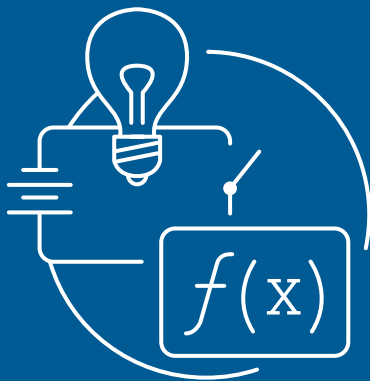

# Selecting and Using Course Materials

---

Teachers will benefit from a wide array of materials to help students become proficient with the science practices and skills necessary to develop a conceptual understanding of the relationships, laws, and phenomena studied in AP Physics C: Electricity and Magnetism. In addition to using a college-level textbook that will provide required course content, students should have regular opportunities to create and use data, representations, and models. Rich, experimental investigation is the cornerstone of AP Physics, and diverse source material allows teachers more flexibility in designing the types of learning activities that will help develop the habits of thinking like a physicist.

## Textbooks

While nearly all college-level physics textbooks address the five units of AP Physics C: Electricity and Magnetism, it's important for teachers to identify other types of secondary sources to supplement the chosen textbook accordingly, ensuring that each of the five topic areas, as well as the science practices, receive adequate attention.

AP Central provides an [example textbook list](#) to help determine whether a text is considered appropriate in meeting the AP Physics C: Electricity and Magnetism Course Audit resource requirement. Teachers can also select textbooks locally.

# Guided Inquiry in AP Physics C: Electricity and Magnetism

---

AP Physics courses require students to engage with data in a variety of ways. The analysis, interpretation, and application of quantitative information are vital skills for students in AP Physics C: Electricity and Magnetism. Scientific inquiry experiences in this course should be designed and implemented with increasing student involvement to help enhance inquiry learning and the development of critical thinking and problem-solving

skills and abilities. Typically, the level of investigations in an AP Physics C: Electricity and Magnetism classroom should focus primarily on the continuum between guided and open inquiry. However, depending on students' familiarity with a topic, a given laboratory experience might incorporate a sequence involving all four levels of inquiry, (confirmation, structured inquiry, guided inquiry, and open inquiry).

# Instructional Strategies

---

The AP Physics C: Electricity and Magnetism course framework outlines the concepts and skills students must master in order to be successful on the AP Exam. To address those concepts and skills effectively, teachers should incorporate a variety of instructional approaches and best practices into their daily lessons and activities. Teachers can help students develop mastery of the skills by engaging them in learning activities that allow them to apply their understanding of course concepts. Teachers may consider the following strategies as they plan instruction. Please note they are listed alphabetically and not by order of importance or instruction.

Strategy	Definition	Purpose	Example
<b><i>Ask the Expert</i></b>	Students are assigned as “experts” on problems they have mastered. Groups rotate through the expert stations to learn about problems they have not yet mastered.	Students share their knowledge and learn from one another.	Assign students as “experts” on questions involving different solution techniques. Have them rotate through stations in groups, working with the station expert to justify a set of claims with corresponding physical laws.
<b><i>Changing Representations</i></b>	These tasks require students to translate from one representation (e.g., an electric field diagram) to another (e.g., an equipotential curves or surfaces diagram). Students often learn how to cope with one representation without really learning the role and value of representations and their relationship to problem solving. Getting them to go back and forth between/among different representations for a concept helps them to develop a more robust understanding of each representation. Among the representations that will be employed are mathematical relationships, so this task can serve, at times, as a bridge between conceptual understanding and traditional problem solving.	Students create pictures, tables, graphs, lists, equations, models, and/or verbal expressions to interpret text or data. This helps organize information using multiple ways to present data and answer a question or show a problem’s solution.	As students learn about electric field, electric force, and potential, ask them to move between different representations (e.g., free-body diagrams of the charges, electric field, and potential diagrams).

*continued on next page*

Strategy	Definition	Purpose	Example
<b><i>Concept-Oriented Demonstration</i></b>	These tasks involve an actual demonstration, but with the students doing as much of the description, prediction, and explanation as possible. Although the demonstration should produce results students don't expect, students should nonetheless feel comfortable making predictions about what will happen.	Involving an actual demonstration, students are asked to predict and explain.	This strategy is useful for helping students to practice writing descriptions, predictions, and explanations. Often when conducting an experiment, data collection takes the most amount of time and gets the most amount of focus, so students mistakenly believe it to be the most important piece. If teachers supplement their longer laboratory experiments with concept-oriented demonstrations, students can practice important laboratory skills (description, prediction, and explanation) without taking huge amounts of class time collecting data.
<b><i>Conflicting Contentions</i></b>	Conflicting contentions tasks present students with two or three statements that disagree in some way, and students decide which contention they agree with and explain why. These tasks are very useful for contrasting statements of students' alternate conceptions with physically accepted statements. This process is facilitated in these tasks because they can be phrased as "which statement do you agree with and why" rather than asking "which statement is correct or true." These tasks complement "What if Anything Is Wrong?" tasks.	These tasks help contrast statements of students' alternate conceptions with physically accepted statements.	This strategy is useful for helping students begin to understand how to write a full argument. By providing the arguments, and having students identify good claims (and not-so-good claims) and good evidence and reasoning (and not-so-good evidence and reasoning), teachers can help scaffold the practice of argumentation for their students.

*continued on next page*

<b>Strategy</b>	<b>Definition</b>	<b>Purpose</b>	<b>Example</b>
<b><i>Construct an Argument</i></b>	Students use mathematical reasoning to present assumptions about mathematical situations, support conjectures with mathematically relevant and accurate data, and provide a logical progression of ideals leading to a conclusion that makes sense.	Helps develop reasoning skills and enhances communication skills in supporting conjectures and conclusions. This strategy also helps develop the process of evaluating mathematical information.	This strategy can be used with word problems that do not lend themselves to immediate application of a formula or mathematical process.
<b><i>Create a Plan</i></b>	Students analyze the tasks in a problem and create a process for completing the tasks by finding the information needed, interpreting data, choosing how to solve a problem, communicating the results, and verifying accuracy.	Assists in breaking tasks into smaller parts and identifying the steps needed to complete the entire task.	When scaffolding how to design an experiment, a good first step is assigning small groups to analyze the tasks necessary to design the experiment. Have students identify the steps needed to answer the question by collecting and analyzing data. Included in this discussion is a plan for what to do with the collected data.
<b><i>Debriefing</i></b>	Students discuss the understanding of a concept to lead to a consensus on its meaning.	Helps clarify misconceptions and deepen understanding of context.	To discern the difference between electric field and potential, have students discuss and address the distinction between the ideas of electric field and potential to help in clarifying the concept and mathematical process.
<b><i>Desktop Experiments Tasks</i></b>	These tasks involve students performing a demonstration at their desks (either in class or at home), using a predict-and-explain format. After doing the experiment, students “reformulate” or reconsider their previous explanations in light of what happened. Desktop experiment tasks are narrow in scope, usually qualitative in nature, and typically use simple equipment.	Students are presented with a small desktop experiment and asked to use the apparatus provided to answer a given question.	Direct Measurement Videos make excellent “desktop” experiments that students can work with either in class or for homework. Desktop experiment tasks can include small experiments using toy cars or spring scales, for example.

*continued on next page*

Strategy	Definition	Purpose	Example
<b><i>Discussion Groups</i></b>	Students work in groups to discuss content, create problem solutions, and explain and justify a solution.	Aids in understanding through the sharing of ideas, interpretation of concepts, and analysis of problem scenarios.	Once students learn all methods of problem solving and can select which is the most appropriate given a particular situation, have them discuss in small groups (no writing) why a specific method should be used over another.
<b><i>Friends Without Pens</i></b>	Students are given a free-response problem, quiz, or challenging problem. This strategy takes place in two rounds: the first round is the timed “friends without pens” round, in which students are grouped together and can discuss—but not write about—the question. At the end of the first round, students return to their desks for the “pens without friends” round, where they tackle the assignment in the traditional, independent sense.	This can be a scaffolding tool if students are being introduced to a new type of assignment or a particularly difficult or challenging AP-level question.	Students identify and discuss, with their peers, adequate claims, evidence, and reasoning. They then return to their desks to create the full argument.
<b><i>Four-Square Problem Solving</i></b>	Students are given a situation, perhaps one that came from a traditional, plug-and-chug problem. They then divide a sheet of paper into four quadrants. In each quadrant, the student(s) put some representation of what is going on in the problem. Possible representations include motion maps or graphs, free-body diagrams, energy bar graphs, momentum bar graphs, mathematical models (equation with symbols), well-labeled diagrams, or written responses (two to three strong clear sentences).	Re-expressing or re-representing data is a key skill necessary for student success in this course. Multiple opportunities with this task scaffolds the needed practice for students to get into the habit of creating and using representations to make claims and answer questions.	In Unit 3, students can regularly and repeatedly complete four-square problem solving with work and energy questions. They can sketch graphs or free-body diagrams, write paragraphs, and solve numerical and/or symbolic problems.

*continued on next page*



Strategy	Definition	Purpose	Example
<b>Graph and Switch</b>	Students generate a graph (or sketch of a graph) to model a certain function, and then switch calculators (or papers) to review each other's solutions.	Allows students to practice creating different representations of functions as well as both giving and receiving feedback on each other's work.	As students learn about graphs of potential energy, have them graph potential energy versus position and force versus position. Students individually graph and explain how their graphs support claims and are consistent with each other. They then share their steps with a partner and receive feedback on their graphs, claims, evidence, and reasoning.
<b>Identify Subtasks</b>	Students break a problem into smaller pieces with outcomes leading to a solution.	Helps organize the pieces of a complex problem and reach a complete solution.	Another scaffolding technique: When first exposing students to AP-level questions that involve several steps of reasoning and logic, additional questions can be added to help guide students to the final claim, evidence, and reasoning. For example, have students sketch a free-body diagram, discuss the system, and/or draw energy bar charts. After the first few units, students should be able to identify (first in groups and then individually) what the subtasks would be (free-body diagram, etc.) to start thinking about the claim, evidence, and reasoning.
<b>Marking the Text</b>	Students highlight, underline, and/or annotate text to focus on key information to help understand the text or solve the problem.	Helps the student identify important information in the text and make notes in the text about the interpretation of tasks required and concepts to apply to reach a solution.	This strategy can be used with AP-level problems as well as problems from the text, or sample laboratory procedures. Have students read through the question, experimental design (or another student's experimental design) and underline the pronouns, equipment, key information (i.e., the car begins at rest), and so on, to identify important information and to be able to ask clarifying questions.

*continued on next page*

Strategy	Definition	Purpose	Example
<b><i>Meaningful, Meaningless Calculations</i></b>	Students are presented with an unreduced expression for a calculation for a physical quantity describing a physical situation. They must decide whether the calculation is meaningful (i.e., it gives a value that tells us something legitimate about the physical situation) or is meaningless (i.e., the expression is a totally inappropriate use of a relation). These calculations should not be trivially meaningless, such as substituting a wrong numerical value into the expression. These items are best when the quantity calculated fits with students' alternative conceptions.	Students are presented with an unreduced calculation for a physical calculation that involves a mathematical relationship, and students are asked if the calculation makes any sense.	These calculations can take many forms, but the most useful are those where the "meaningless" calculations illustrate common student misconceptions. Students could be asked about a situation in which there is a uniform magnetic field of specified magnitude directed toward the left and an electron traveling parallel to the field at a speed of 300 m/s. The students could then be told, "A student finds the magnetic force acting on the electron as the product of the speed, the charge, and the magnitude of the field. Is this a meaningful calculation for this situation?"
<b><i>Model Questions</i></b>	Students answer items from released AP Physics Exams.	Provides rigorous practice and assesses students' ability to apply multiple physical practices on content as either a multiple-choice or a free-response question.	Model questions can be AP released or AP-level questions. These questions can be given as written or scaffolded for students earlier in the year to provide them with support.
<b><i>Note Taking</i></b>	Students create a record of information while reading a text or listening to a speaker.	Helps organize ideas and process information.	Have students write down verbal descriptions of the steps needed to solve a problem so that a record of the processes can be referred to at a later point in time.

*continued on next page*

Strategy	Definition	Purpose	Example
<b><i>Predict and Explain</i></b>	Predict and explain tasks describe a physical situation that is set up at a point where some event is about to occur. Students predict and explain what they think will happen. These tasks must involve situations with which the students are familiar or have sufficient background information in to enable them to understand the situation. This is important, because otherwise students usually do not feel comfortable enough to attempt to answer.	Stimulates thinking by asking students to make, check, and correct predictions based on evidence from the outcome.	When a pair of capacitors is set into a circuit, what would happen to the time to charge and/or discharge the circuit if a third capacitor is set in series with the original two capacitors?
<b><i>Qualitative Reasoning</i></b>	These tasks can take a variety of forms, with their common denominator being qualitative analysis. Frequently, students are presented with an initial and final situation and asked how some quantity, or aspect, will change. Qualitative comparisons (e.g., the quantity increases, decreases, or stays the same) are often the appropriate answer. Qualitative reasoning tasks can frequently contain elements found in some of the other task formats (e.g., different qualitative representations and a prediction or explanation).	Students are presented with a physical situation and asked to apply a principle to qualitatively reason what will happen. These questions are commonly found in multiple-choice question subtypes.	Ask students what would happen to the electric field surrounding a uniformly charged conducting sphere if the sphere were to have twice the charge, half the radius, or has become a hollow shell. Additional questions could include asking the students about the electric field inside the sphere versus inside the shell.
<b><i>Quickwrite</i></b>	Students write for a short, specific amount of time about a designated topic.	Helps generate ideas in a short amount of time.	To help synthesize concepts after having learned how to calculate the derivative, students list as many real-world situations as possible in which knowing the instantaneous rate of change of a function is advantageous.

*continued on next page*

Strategy	Definition	Purpose	Example
<b>Ranking</b>	Ranking tasks present students with a set of variations—sometimes three or four but usually six to eight—on a basic physical situation. The variations not only differ in value (numeric or symbolic) for the variables involved but also frequently include variables that are not important to the task. The students' objective is to rank the variations on the basis of a specified physical quantity. Students must also explain the reasoning for their ranking scheme and rate their confidence in their ranking.	These tasks require students to engage in a comparison reasoning process that they seldom have opportunities to do in traditional problem solving.	Given six different circuits containing identical resistors, students are asked to rank the circuits by greatest total resistance.
<b>Sharing and Responding</b>	Students communicate with another person or a small group of peers who respond to a proposed problem solution.	Gives students the opportunity to discuss their work with peers, make suggestions for improvement to the work of others, and/or receive appropriate and relevant feedback on their own work.	Group students to review individual work (graphs, derivations, problem solutions, experimental designs, etc.). Have the groups make any necessary corrections and build a single complete solution together.
<b>Simplify the Problem</b>	Students use "friendlier" numbers or functions to help solve a problem.	Provides insight into the problem or the strategies needed to solve the problem.	For example, have students use the definition of an electric field surrounding a point charge to model the electric field around a uniformly charged conducting sphere.
<b>Troubleshooting</b>	Troubleshooting tasks are variations on the "What if Anything Is Wrong?" task. Students are explicitly told that there is an error in the given situation. Their job is to determine what the error is and explain how to correct it. These tasks can often produce interesting insights into students' thinking because they will, at times, identify some correct aspect of the situation as erroneous. This helps develop additional items.	Allows students to troubleshoot errors and misconceptions by focusing on problems that may arise when they do the same procedures themselves.	Provide students with a derivation or problem solution and ask them to find the incorrect step(s). Students must not only identify, but also explain, the mistake or misunderstanding that led to the mistake. This can also be done with diagrams and other representations.

*continued on next page*

Strategy	Definition	Purpose	Example
<b><i>“What if Anything Is Wrong?”</i></b>	Requires students to analyze a statement or diagrammed situation to determine whether it is correct or not. If everything is correct, the student is asked to explain the statement/situation and why it works as described. If something is incorrect, the student has to identify the error and explain how to correct it. These are open-ended exercises, so they provide insight into students’ ideas, since they will often have interesting reasons for accepting incorrect situations and for rejecting legitimate situations. Often, students’ responses provide ideas for other items.	Allows students to troubleshoot errors and focus on problems that may arise when they do the same procedures themselves.	Provide students a force diagram that may or may not have incorrect forces drawn on it. Or, give students graphs of force and potential energy that “match” and ask them to determine whether the graphs do indeed correspond. This technique can also be used in derivations and problem solving where students are given the “complete” solution and are asked to verify that it was done correctly.
<b><i>Write and Switch</i></b>	Like graph and switch, but with writing. Students make observations, collect data, or make a claim and then switch papers.	Allows students to practice writing and giving and receiving feedback on each other’s work.	As students learn about creating an argument, they can draft an initial argument themselves, share their claim, evidence and reasoning with a partner, and receive feedback on their argument.
<b><i>Working Backward</i></b>	This task reverses the order of the problem steps. For example, the given information could be an equation with specific values for all, or all but one, of the variables. The students must then construct a physical situation for which the given equation would apply. Such working backward tasks require students to take numerical values, including units, and translate them into physical variables. Working backward problems also require students to reason about these situations in an unusual way, and they often allow for more than one solution.	Provides another way to check possible answers for accuracy.	Students are given an equation such as $4m = 6\frac{m}{s} - 9\frac{m}{s^2}$ and are asked to create another representation from this equation. For example, a written scenario that this equation could represent may include position versus time graphs, velocity versus time graphs, motion maps, and so on.

# Developing the Science Practices

Throughout the course, students will develop skills that are fundamental to the discipline of physics. Since these practices represent the complex skills that adept physicists demonstrate, students will benefit from multiple opportunities to develop them in a scaffolded manner. Through the use of guided questioning, discussion techniques, and other instructional strategies, teachers can help their students practice applying these skills in new contexts, providing an important foundation for their college and career readiness.

## Science Practice 1: Visual Representations

**Analyze and/or use [non-narrative/non-mathematical] representations of physical situations, excluding graphs.**

The real world is extremely complex. When physicists describe and explain phenomena, they try to simplify real objects, systems, and processes to make the analysis manageable. These simplifications or models are used to predict how new phenomena will occur. A simple model may treat a system as an object, neglecting the system’s internal structure and behavior. More complex models are models of a system of objects, such as an ideal gas. A process can be simplified, too, and models can be both conceptual and mathematical. To make a good model, one needs to identify a set of the most important characteristics of a phenomenon or system that may simplify analysis. Inherent in the construction of models that physicists invent is the use of representations. Examples of representations used to model introductory physics are pictures, free-body diagrams, force diagrams, graphs, energy bar charts, and momentum bar charts. Representations help in analyzing phenomena, making predictions, and communicating ideas. AP Physics C: Electricity and Magnetism requires students to use and/or analyze and/or re-express models and representations of natural or man-made systems.

The following table provides examples of questions and instructional strategies for implementing visual representation resources into the course:

Skills	Key Questions	Instructional Notes or Sample Activities	Instructional Strategies
<b>1.A</b> Describe the physical meaning (includes identifying features) of a representation.	<ul style="list-style-type: none"> <li>What does the representation show?</li> </ul>	Have students describe the physical features and meaning of figures and representations including figures and representations from the textbook and other reference sources.	<ul style="list-style-type: none"> <li>Label and Describe</li> <li>“What if Anything Is Wrong?”</li> <li>Graph and Switch</li> <li>Discussion Groups</li> </ul>
<b>1.B</b> Describe the relationships between different types of representations of the same physical situation.	<ul style="list-style-type: none"> <li>What is the relationship between the representations?</li> <li>What is the relationship between the variables represented?</li> </ul>	Have students match representations that are of the same physical situation, and explain what characteristics help them recognize that the representations are of the same situation.	<ul style="list-style-type: none"> <li>“What if Anything Is Wrong?”</li> <li>Changing Representations</li> </ul>

*continued on next page*

Skills	Key Questions	Instructional Notes or Sample Activities	Instructional Strategies
<p><b>1.C</b> <i>Demonstrate consistency between different types of representations of the same physical situation.</i></p>	<ul style="list-style-type: none"> <li>▪ What characteristic or physical quantity of the situation does each representation illustrate?</li> <li>▪ How do the representations show consistency?</li> </ul>	<p>Have students divide their paper into four quarters and provide four different representations for a given physical situation. Representations can include an equation, a written sentence (or paragraph), a graph, a bar chart, or sketch of the physical scenario.</p>	<ul style="list-style-type: none"> <li>▪ “What if Anything Is Wrong?”</li> <li>▪ Changing Representations</li> <li>▪ Four-Square Problem Solving</li> </ul>
<p><b>1.D</b> <i>Select relevant features of representations to answer a question or solve a problem.</i></p>	<ul style="list-style-type: none"> <li>▪ What does the representation show?</li> <li>▪ What features of the representation provide information relevant to the question or problem?</li> </ul>	<p>Have students practice identifying relevant features of representations by having them identify features of representations without questions attached. Old AP Physics C: Electricity and Magnetism question prompts are good sources of practice representations.</p>	<ul style="list-style-type: none"> <li>▪ “What if Anything Is Wrong?”</li> <li>▪ Changing Representations</li> </ul>
<p><b>1.E</b> <i>Describe the effects of modifying conditions or features of a representation of a physical situation.</i></p>	<ul style="list-style-type: none"> <li>▪ What assumptions are being made in this physical situation?</li> <li>▪ What changes would occur if these assumptions were altered (e.g., how would a free-body diagram of an object in free fall change if air resistance was included in the analysis?)?</li> <li>▪ What assumptions are being made in the creation of the representation?</li> <li>▪ If changes are made to the representation, how would that affect the physical situation?</li> </ul>	<p>Have students practice modifying assumptions about every problem they do. On homework, class work, quizzes, and tests, students can be asked to explain how modifying assumptions about representations will alter the physical situation and how changing the physical situation will alter the representations.</p>	<ul style="list-style-type: none"> <li>▪ Qualitative Reasoning</li> <li>▪ Four-Square Problem Solving</li> </ul>

## Science Practice 2: Question and Method

### Determine scientific questions and methods.

Scientific questions can range in scope from broad to narrow, as well as in specificity, from determining influencing factors and/or causes to determining mechanism. The question posed will determine the type of data to be collected and will influence the plan for collecting data. Designing and improving experimental designs and/or data collection strategies is a learned skill. Class discussion can reveal issues of measurement uncertainty and assumptions in the data collection. Students need to understand that the results of collecting and using data to determine a numerical answer to a question is best thought of as an interval, not a single number. This interval, the experimental uncertainty, is due to a combination of uncertainty in the instruments used and the process of taking the measurement. Although detailed error analysis is not necessary to convey this pivotal idea, it is important that students make some reasoned estimate of the interval within which they know the value of a measured data point and express their results in a way that makes this clear.

Laboratory experience is also important in helping students understand the topics being considered. Thus it is valuable to ask students to write informally about what they have done, observed, and concluded in well-organized laboratory notebooks. Some questions or parts of questions on the AP Physics C: Electricity and Magnetism Exam deal with lab-related skills, such as design of experiments, data analysis, and error analysis, and are intended to distinguish between students who have had laboratory experience and those who have not. In addition, the understanding gained in the laboratory may improve a student's test performance overall.

Examples of scientific experiments include guided, inquiry-based, hands-on lab investigations; individual, hands-on lab investigations; lab demonstrations; or lab-based, hands-on classroom activities.

The following table provides examples of questions and instructional strategies for implementing question and method resources into the course:

Skills	Key Questions	Instructional Notes or Sample Activities	Instructional Strategies
<b>2.A</b> <i>Identify a testable scientific question based on an observation, data, or a model.</i>	<ul style="list-style-type: none"> <li>What differentiates a testable or scientific question from a nonscientific question?</li> </ul>	Have students list questions about a topic, and then in groups have them choose and refine one of the questions into a scientifically testable question.	<ul style="list-style-type: none"> <li>Discussion Groups</li> <li>Create a Plan</li> </ul>
<b>2.B</b> <i>Make a claim or predict the results of an experiment.</i>	<ul style="list-style-type: none"> <li>What hypotheses or predictions can be made about the physical situation?</li> <li>What types of evidence could be collected to defend the hypotheses or prediction?</li> </ul>	Have students list possible hypotheses and/or predictions and the necessary evidence to defend each.	<ul style="list-style-type: none"> <li>Concept-Oriented Demonstration</li> <li>Predict and Explain</li> </ul>

*continued on next page*



Skills	Key Questions	Instructional Notes or Sample Activities	Instructional Strategies
<p><b>2.C</b> <i>Identify experimental procedures that are aligned to the question (which may include a sketch of a lab setup).</i></p>	<ul style="list-style-type: none"> <li>▪ What information will be needed to answer the scientific question?</li> <li>▪ What equipment is needed to collect the necessary data?</li> <li>▪ How will each piece of equipment be used to collect the necessary data?</li> <li>▪ What will be done with the data (data analysis) to answer the scientific question?</li> </ul>	<p>Have students practice designing plans for collecting data to answer scientific questions. Laboratory design procedures do <i>not</i> always have to be carried out.</p>	<ul style="list-style-type: none"> <li>▪ Create a Plan</li> <li>▪ Troubleshooting</li> <li>▪ Desktop Experiment</li> </ul>
<p><b>2.D</b> <i>Make observations or collect data from representations of laboratory setups or results.</i></p>	<ul style="list-style-type: none"> <li>▪ What observations can be recorded from the beginning/middle/end of the experiment?</li> <li>▪ Are these qualitative or quantitative observations? If they are qualitative, is there a way to make them quantitative?</li> <li>▪ What quantitative data can be collected from the laboratory setup or results?</li> </ul>	<p>Have students list the possible “human errors,” to be aware of how poor measurement techniques can affect collected observations and/or data. So-called human errors should be reduced as much as possible. Students should not refer to “human error” as the source of uncertainty in measurement.</p>	<ul style="list-style-type: none"> <li>▪ Write and Switch</li> <li>▪ Desktop Experiment</li> </ul>
<p><b>2.E</b> <i>Identify or describe potential sources or experimental error.</i></p>	<ul style="list-style-type: none"> <li>▪ What possible human errors need to be addressed before data collection?</li> <li>▪ What inherent errors in data collection need to be addressed in the final result of the experiment?</li> <li>▪ How do the inherent errors affect the final result of the experiment?</li> </ul>	<p>Have students list the common sources of uncertainty and error. Then students can identify and/or describe the manner or way in which each source would affect the results of the experiment.</p>	<ul style="list-style-type: none"> <li>▪ Troubleshooting</li> <li>▪ Desktop Experiment</li> </ul>
<p><b>2.F</b> <i>Explain modifications to an experimental procedure that will alter results.</i></p>	<ul style="list-style-type: none"> <li>▪ What modifications could be accomplished for the physical situation?</li> <li>▪ How will each modification alter the results of the experimental procedure?</li> </ul>	<p>Have students perform a write and switch to explain how modifications to an experimental procedure will alter results of the experiment. For example, how inserting a dielectric into a homemade capacitor will change the capacitance, and the time for the capacitor to charge and/or discharge.</p>	<ul style="list-style-type: none"> <li>▪ Desktop Experiment</li> <li>▪ Write and Switch</li> <li>▪ Predict and Explain</li> </ul>

## Science Practice 3: Representing Data and Phenomena

### Create visual representations or models of physical situations.

The AP Physics C: Electricity and Magnetism course requires several key skills, including drawing and interpreting graphs and representing data or physical relationships in graphical form. Students need to be able to think about the material in their physics courses in terms of conceptual, verbal, graphical, and mathematical ideas. As part of these comprehensive skills for understanding the physical world around them, students must be able to perform graphical analysis in its many forms. With the use of graphing calculators, students appear to be losing the ability to draw, interpret, and understand graphs. There appears to be a disconnect between what students learn in their mathematics courses and how they apply that knowledge in their physics course. For example, even if students have learned graphing in previous math courses and understand the concept of slope, they may have difficulty understanding that the slope of a displacement-versus-time graph is the velocity. The AP Physics C: Electricity and Magnetism course should provide opportunities to bridge the gap between physics and mathematics for students.

The following table provides examples of strategies for implementing data and phenomena representation resources into the course:

Skills	Key Questions	Instructional Notes or Sample Activities	Instructional Strategies
<b>3.A</b> <i>Select and plot appropriate data.</i>	<ul style="list-style-type: none"> <li>What data should be plotted?</li> <li>What scale and axis labels should be used?</li> </ul>	Have students identify data that can be graphed in new situations, without the help of understanding ahead of time the relationships between the quantities being investigated.	<ul style="list-style-type: none"> <li>"What if Anything Is Wrong?"</li> <li>Graph and Switch</li> <li>Discussion Groups</li> </ul>
<b>3.B</b> <i>Represent features of a model or the behavior of a physical system using appropriate graphing techniques, appropriate scale, and units.</i>	<ul style="list-style-type: none"> <li>What important physical features can be represented by a graph?</li> <li>What quantities should be graphed in order to represent the model or system?</li> <li>What does an appropriately scaled graph look like?</li> <li>What does a graph need to contain to be called "correctly labeled"?</li> </ul>	Have students identify correct graphs by giving them a "What if Anything Is Wrong?" task. Present students with a set of data and matching graph and have them identify what, if anything, is wrong with the graph. The "wrong" things can be simple at first (scales not uniform, labels left off), and then later in the course can be scaffolded to be more difficult and address student misconceptions.	<ul style="list-style-type: none"> <li>"What if Anything Is Wrong?"</li> <li>Graph and Switch</li> <li>Changing Representations</li> </ul>

*continued on next page*

Skills	Key Questions	Instructional Notes or Sample Activities	Instructional Strategies
<p><b>3.C</b> <i>Sketch a graph that shows a functional relationship between two quantities.</i></p>	<ul style="list-style-type: none"> <li>▪ What are the main functional relationships needed to represent phenomena?</li> <li>▪ What is the relationship between the two physical quantities?</li> </ul>	<p>Have students sketch a graph that shows a functional relationship between two quantities and then have them switch with a partner to give and receive feedback on each other's work.</p>	<ul style="list-style-type: none"> <li>▪ Graph and Switch</li> <li>▪ Troubleshooting</li> <li>▪ Identify Subtasks</li> </ul>
<p><b>3.D</b> <i>Create appropriate diagrams to represent physical situations.</i></p>	<ul style="list-style-type: none"> <li>▪ What types of diagrams can be used to represent different kinds of physical situations?</li> <li>▪ How many different kinds of representations can be used for a physical scenario?</li> </ul>	<p>Have students practice creating appropriate diagrams by giving them working backward tasks. Give students a full problem solution and ask them to create appropriate diagrams (e.g., force diagrams or free-body diagrams) that match the problem solution.</p>	<ul style="list-style-type: none"> <li>▪ Working Backward</li> <li>▪ Graph and Switch</li> </ul>

## Science Practice 4: Data Analysis

### Analyze quantitative data represented in graphs.

Students often think that to make a graph they need to connect the data points or that the best-fit function is always linear. Thus, it is important that they can construct a best-fit curve even for data that do not fit a linear relationship. Students should be able to represent data points as intervals whose size depends on the experimental uncertainty. After students find a pattern in the data, they need to ask why this pattern is present and try to explain it using the knowledge that they have. When dealing with a new phenomenon, they should be able to devise a testable explanation of the pattern if possible. It is important that students understand that instruments do not produce exact measurements and learn what steps they can take to decrease the uncertainty.

Students should be able to design a second experiment to determine the same quantity and then check for consistency across the two measurements, comparing two results by writing them both as intervals and not as single, absolute numbers. Finally, students should be able to revise their reasoning based on the new data, data for some that may appear anomalous. The analysis, interpretation, and application of quantitative information are vital skills for students in AP Physics C: Electricity and Magnetism. Analysis skills can be taught using any type of data, but students will be more invested in the data analysis if it is data they have collected through their own investigations. Teachers should provide opportunities for students to analyze data, draw conclusions, and apply their knowledge of the enduring understandings and learning objectives.

The following table provides examples of questions and instructional strategies for implementing data analysis resources into the course:

Skills	Key Questions	Instructional Notes or Sample Activities	Instructional Strategies
<b>4.A</b> <i>Identify and describe patterns and trends in the data or graph.</i>	<ul style="list-style-type: none"><li>What does the data or graph show?</li><li>What trends and patterns can you identify from the data?</li></ul>	Have students practice identifying and describing trends by assigning a “friends without pens” task. Give students a difficult data set or graph and let them discuss (without writing anything down) for a short period of time. Then have students return to their seats and fully identify and describe the patterns in the given data or graph.	<ul style="list-style-type: none"><li>Friends Without Pens</li><li>Write and Switch</li><li>Predict and Explain</li></ul>

*continued on next page*

Skills	Key Questions	Instructional Notes or Sample Activities	Instructional Strategies
<p><b>4.B</b> <i>Demonstrate consistency between different graphical representations of the same physical situation.</i></p>	<ul style="list-style-type: none"> <li>▪ What physical feature(s) do the representations have in common?</li> <li>▪ How do the representations demonstrate consistency?</li> <li>▪ What would a representation look like if it were inconsistent?</li> <li>▪ What other representations could be created that would also be consistent with the physical situation?</li> <li>▪ How could the current representation be changed to be nontraditional, but still be a consistent representation? (For example, a momentum versus time graph could be re-represented as a net force versus time graph.)</li> </ul>	<p>Have students practice demonstrating consistency between graphical representations by doing four-square problem solving. Students are given a physical scenario from the textbook, AP Exam, or other source, and are asked to create four consistent representations that match the physical scenario. Examples of representations include, but are not limited to, sketches, graphs, free-body diagrams, force diagrams, potential diagrams, and or/electric field diagrams.</p>	<ul style="list-style-type: none"> <li>▪ Four-Square Problem-Solving</li> </ul>
<p><b>4.C</b> <i>Linearize data and/or determine a best fit line or curve.</i></p>	<ul style="list-style-type: none"> <li>▪ What information is being represented and what is the relationship between the variables being graphed?</li> <li>▪ What variables would need to be graphed to create a linear relationship?</li> <li>▪ What is the physical meaning of the slope and/or area underneath the linearized graph?</li> <li>▪ What is the physical meaning of the <math>y</math> and/or <math>x</math> intercept of the linearized graph?</li> </ul>	<p>Have students practice linearization whenever possible in laboratory activities and provide students with practice on equations they have never seen before, including mathematical relationships (e.g., volume of a sphere versus the radius of the sphere), relationships beyond the scope of the course (e.g., magnitude of electric field versus distance from point charge), and even fictional relationships (create fictional equations and have students discuss how the variables could be rearranged to linearize).</p>	<ul style="list-style-type: none"> <li>▪ Create a Plan</li> <li>▪ Write and Switch/Graph and Switch</li> </ul>

*continued on next page*

Skills	Key Questions	Instructional Notes or Sample Activities	Instructional Strategies
<p><b>4.D</b> <i>Select relevant features of a graph to describe a physical situation or solve problems.</i></p>	<ul style="list-style-type: none"> <li>▪ What is the physical meaning of the slope and/or area underneath the graph?</li> <li>▪ What is the physical meaning of the <math>y</math> and/or <math>x</math> intercept of the graph?</li> <li>▪ How can the data represented in the graph help answer the question or solve a problem?</li> <li>▪ What is the relationship between the information gained from interpreting the graph and the question being asked?</li> </ul>	<p>Have students practice selecting and using relevant features of graphs to describe physical situations or problems by giving them ranking tasks. Ranking tasks with graphs including extraneous information helps students practice sorting through information in graphical form to determine what information and features are relevant to the problem or physical situation.</p>	<ul style="list-style-type: none"> <li>▪ Ranking</li> <li>▪ Graph and Switch</li> <li>▪ Friends Without Pens</li> </ul>
<p><b>4.E</b> <i>Explain how the data or graph illustrates a physics principle, process, concept, or theory.</i></p>	<ul style="list-style-type: none"> <li>▪ What information or data is being graphed?</li> <li>▪ What is the relationship between the variables in the graph?</li> <li>▪ What kinds of claim could be made about the graph?</li> <li>▪ What evidence from the graph could be used to support the claim?</li> <li>▪ What physical process, principle, concept, or theory can connect the evidence provided by the graph to the claim?</li> </ul>	<p>Have students practice constructing an argument by giving students graphs or data, and then ask students to construct mathematical arguments, either in support of or in opposition to the claim that the graph or data illustrates a given process, concept, or theory.</p>	<ul style="list-style-type: none"> <li>▪ Construct an Argument</li> <li>▪ Write and Switch</li> <li>▪ Conflicting Contentions</li> </ul>

## Science Practice 5: Theoretical Relationships

### Determine the effects on a quantity when another quantity or the physical situation changes.

Physicists commonly use mathematical representations to describe and explain phenomena as well as to solve problems. When students work with these representations, they should understand the connections between the mathematical description, the physical phenomena, and the concepts represented in the mathematical descriptions. When using equations or mathematical representations, students need to be able to justify why using a particular equation to analyze a particular situation is useful as well as to be aware of the conditions under which the equations/mathematical representations can be used. Because students tend to rely too much on mathematical representations, when solving a problem they need to be able to describe the problem situation in multiple ways, including pictorial representations and force diagrams, and then choose an appropriate mathematical representation instead of first choosing a formula whose variables seem to match the givens in the problem.

Students should be able to work with the algebraic form of the equation before substituting values, and should be able to evaluate the equation(s) and the answer in terms of units and limiting case analysis. Students should also be able to translate between functional relationships in equations (proportionalities, inverse proportionalities, etc.) and cause-and-effect relationships in the physical world. Finally, students are expected to be able to evaluate a numerical result in terms of whether it makes sense. In many physical situations, simple mathematical routines may be needed to arrive at a result even though they are not the focus of a learning objective.

The following table provides examples of questions and instructional strategies for implementing theoretical relationship resources into the course:

Skills	Key Questions	Instructional Notes or Sample Activities	Instructional Strategies
<b>5.A</b> <i>Select an appropriate law, definition, or mathematical relationship or model to describe a physical situation.</i>	<ul style="list-style-type: none"> <li>What clues are given in the problem that can help identify what fundamental physics law, relationship, or equation should be applied to the situation?</li> </ul>	Have students identify which main law, definition, or mathematical relationship should be used based solely on question stems. (AP Physics C: Electricity and Magnetism question stems are a great source of material.)	<ul style="list-style-type: none"> <li>Write and Switch</li> <li>Working Backward</li> </ul>
<b>5.B</b> <i>Determine the relationship between variables within an equation when an existing variable changes.</i>	<ul style="list-style-type: none"> <li>Can the relationship be rewritten so that the variable in question is alone on one side of the equation?</li> <li>What symbols in the relationship are constants versus variables that can change?</li> <li>What potential variables cannot change in this situation?</li> </ul>	<p>Have students practice determining relationships between variables by giving them qualitative reasoning tasks. Present students with a physical situation and asked to apply a principle to qualitatively reason out what will happen.</p> <p>For example, give students a scenario in which a magnetic force is being applied to a charged object and ask them to determine the relationship between force and acceleration when the charge of the object increases.</p>	<ul style="list-style-type: none"> <li>Qualitative Reasoning</li> <li>Graph and Switch</li> </ul>

*continued on next page*

Skills	Key Questions	Instructional Notes or Sample Activities	Instructional Strategies
<p><b>5.C</b> Determine the relationship between variables within an equation when a new variable is introduced.</p>	<ul style="list-style-type: none"> <li>▪ What relationship exists between variables originally?</li> <li>▪ How does the introduction of the new variable affect the original relationship?</li> </ul>	<p>Have students practice determining the relationships between variables by using conflicting contentions tasks. Give students an equation and a scenario where a new variable is introduced, and ask two students' opinions on the new relationship after the introduction of the new variable. Have students identify which claim is correct and explain why.</p>	<ul style="list-style-type: none"> <li>▪ Conflicting Contentions</li> <li>▪ Qualitative Reasoning</li> </ul>
<p><b>5.D</b> Determine or estimate the change in a quantity using a mathematical relationship.</p>	<ul style="list-style-type: none"> <li>▪ How can the mathematical relationship be rearranged so the variables in question can be easily recognized and the relationships understood?</li> <li>▪ How can relationships be modified or combined to estimate or calculate values?</li> <li>▪ Is there more than one way to calculate or estimate the quantity needed?</li> </ul>	<p>Have students practice determining the change in a quantity by giving them qualitative reasoning tasks. Present students with a physical situation and ask them to apply a principle to qualitatively reason what will happen.</p>	<ul style="list-style-type: none"> <li>▪ Qualitative Reasoning</li> <li>▪ Identify Subtasks</li> </ul>
<p><b>5.E</b> Determine a symbolic expression from known quantities by selecting and following a logical algebraic pathway.</p>	<ul style="list-style-type: none"> <li>▪ What is the fundamental physics principle, law, or relationship that relates to the given physical scenario?</li> <li>▪ How does that fundamental physics principle, law, or relationship combine with given information and/or other physical laws to help derive a logical pathway to the desired solution?</li> </ul>	<p>Have students practice determining symbolic expressions with a write and switch. Ask students to derive an expression and work on it individually for a short period of time. Then, have them switch papers and share their steps with a partner. Both students receive feedback on their derivation (including whether it follows a logical algebraic pathway) and final symbolic expression.</p>	<ul style="list-style-type: none"> <li>▪ Model Questions</li> <li>▪ Write and Switch</li> </ul>



## Science Practice 6: Mathematical Routines

### Solve problems of physical situations using mathematical relationships.

Students need to be proficient in problem solving and in the application of fundamental principles to a wide variety of situations. Problem-solving abilities can be fostered by scaffolded practice and exposure to a range of challenging problems. In general, the purpose of allowing calculators and equation sheets to be used on both sections of the AP Physics C: Electricity and Magnetism Exam is to place greater emphasis on the understanding and application of fundamental physical principles and concepts. The availability of equations for all students means that, on the exam, little or no credit will be awarded for simply writing down equations. For solving problems, a sophisticated scientific or graphing calculator is no substitute for a thorough grasp of the physics involved. It should be noted that although fewer topics are covered in AP Physics C: Electricity and Magnetism than in AP Physics 1, they are covered in greater depth and with greater analytical and mathematical sophistication, including calculus applications.

The following table provides examples of questions and instructional strategies for implementing mathematical routine resources into the course:

Skills	Key Questions	Instructional Notes or Sample Activities	Instructional Strategies
<p><b>6.A</b> <i>Extract quantities from narratives or mathematical relationships to solve problems.</i></p>	<ul style="list-style-type: none"> <li>What quantities are given?</li> <li>What quantity is needed to answer the question?</li> <li>What relationship(s) link the needed with the given quantities?</li> </ul>	<p>Have students practice extracting quantities from narratives and/or mathematical relationships by giving them working backward tasks. These tasks require students to reason about physical situations in an unusual way, and often allow for more than one solution. For example, give students the following equation and ask them to create another representation or a written explanation of the physical scenario.</p> $\mu_s (200\text{kg})(9.8\text{m/s}^2)\cos 30^\circ = (200\text{kg})(9.8\text{m/s}^2)\sin 30^\circ$	<ul style="list-style-type: none"> <li>Working Backward</li> <li>Simplify the Problem</li> </ul>
<p><b>6.B</b> <i>Apply an appropriate law, definition, or mathematical relationship to solve a problem.</i></p>	<ul style="list-style-type: none"> <li>What laws, definitions, or mathematical relationships exist that relate the given problem?</li> <li>What are the rules, assumptions, or limitations surrounding the use of the chosen law, definition, or relationship?</li> </ul>	<p>Have students practice applying an appropriate law, definition, or mathematical relationship with a write and switch. Ask students to derive an expression or solve a problem, giving them a short amount of time to work on it individually. Students then switch papers and share their steps with a partner. Both students receive feedback on their derivation or problem solution (including whether it follows a logical algebraic pathway).</p>	<ul style="list-style-type: none"> <li>Write and Switch</li> <li>Simplify the Problem</li> <li>Ask the Expert</li> </ul>

*continued on next page*

Skills	Key Questions	Instructional Notes or Sample Activities	Instructional Strategies
<p><b>6.C</b> Calculate an unknown quantity with units from known quantities by selecting and following a logical computational pathway.</p>	<ul style="list-style-type: none"> <li>▪ Did the calculation begin with an equation or fundamental physics relationship, law, or definition?</li> <li>▪ Are the steps clearly written out and annotated?</li> <li>▪ Are any steps skipped?</li> <li>▪ Is the unknown quantity clearly labeled as the final answer, complete with units?</li> </ul>	<p>Have students practice calculating unknown quantities from known quantities by assigning them a “What if Anything Is Wrong?” task. These tasks focus a student’s attention on troubleshooting errors and misconceptions by focusing on problems that may arise when they do the same procedures themselves.</p>	<ul style="list-style-type: none"> <li>▪ “What if Anything Is Wrong?”</li> <li>▪ Model Questions</li> <li>▪ Discussion Groups</li> </ul>
<p><b>6.D</b> Assess the reasonableness of results or solutions.</p>	<ul style="list-style-type: none"> <li>▪ What does “reasonable” mean for a numeric solution?</li> <li>▪ What does “reasonable” look like for a symbolic solution?</li> <li>▪ How can a result or solution be double checked for “reasonableness?”</li> </ul>	<p>Have students practice assessing the reasonableness of a result or solution by assigning them a meaningful, meaningless calculation task. For example, if asked to write an expression for the energy of a system, students have to decide which of the following expressions are <i>meaningful</i>. (MgD, Mg/D, MD/g, 1/MgD)</p>	<ul style="list-style-type: none"> <li>▪ Meaningful, Meaningless Calculations</li> <li>▪ Working Backward</li> </ul>

## Science Practice 7: Argumentation

### Develop an explanation or scientific argument.

A scientific explanation, accounting for an observed phenomenon, needs to be experimentally testable. One should be able to use it to make predictions about new phenomenon. A theory uses a unified approach to account for a large set of phenomena and gives accounts that are consistent with multiple experimental outcomes within the range of applicability of the theory. Examples of theories in physics include the kinetic molecular theory, quantum theory, and atomic theory. Students should understand the difference between explanations and theories.

Students should be prepared to offer evidence to construct reasoned arguments for their claim from the evidence, and to use the claim or explanation to make predictions. A prediction states the expected outcome of a particular experimental design based on an explanation or a claim under scrutiny.

Physicists examine data and evidence to develop claims about physical phenomena. As they articulate their claims, physicists use reasoning processes that rely on their awareness of different types of relationships, connections, and patterns within the data and evidence. They then formulate a claim and develop an argument that explains how the claim is supported by the available evidence. AP Physics C: Electricity and Magnetism teachers should help students learn how to create persuasive and meaningful arguments by improving their proficiency with each of these skills.

The following table provides examples of questions and instructional strategies for implementing argumentation resources into the course:

Skills	Key Questions	Instructional Notes or Sample Activities	Instructional Strategies
<b>7.A</b> <i>Make a scientific claim.</i>	<ul style="list-style-type: none"> <li>What possible claims could you make based on the question and the evidence?</li> <li>What claim will you make?</li> <li>What is your purpose? (To define, show causality, compare, or explain a process?)</li> <li>What evidence supports your claim?</li> <li>How does the evidence support your claim?</li> </ul>	<p>Have students identify and explain the evidence that supports their claim, with an emphasis on <i>how</i> the evidence supports the claim.</p> <p>Give students a question, such as “Which of the following is most responsible for ...?”</p> <p>Students should analyze possibilities and the evidence for and against each position. Have students choose a position and write a defensible claim or thesis that reflects their reasoning and evidence.</p>	<ul style="list-style-type: none"> <li>Conflicting Contentions</li> </ul>

*continued on next page*

Skills	Key Questions	Instructional Notes or Sample Activities	Instructional Strategies
<p><b>7.B</b> <i>Support a claim with evidence from experimental data.</i></p>	<ul style="list-style-type: none"> <li>▪ What possible claims could you make based on the question and the evidence?</li> <li>▪ What claim will you make?</li> <li>▪ What is your purpose? (To define, show causality, compare, or explain a process?)</li> <li>▪ What evidence supports your claim?</li> <li>▪ How does the evidence support your claim?</li> </ul>	<p>Have students identify and explain the experimental data that support their claim, with an emphasis on <i>how</i> the data support the claim. This can be practiced by giving students a debriefing activity. After students complete a laboratory activity and collect data, have them meet in groups to discuss the understanding of the data to lead to a consensus on its meaning. This helps clarify misconceptions and deepen the understanding of the relationship between evidence and claims.</p>	<ul style="list-style-type: none"> <li>▪ Predict and Explain</li> <li>▪ Debriefing</li> <li>▪ Quick Write</li> </ul>
<p><b>7.C</b> <i>Support a claim with evidence from physical representations.</i></p>	<ul style="list-style-type: none"> <li>▪ What physical representations are valid in this physical scenario?</li> <li>▪ What physical representation supports your claim?</li> <li>▪ How does the physical representation support your claim?</li> </ul>	<p>Have students identify and explain the evidence from physical representations (graphs, free-body diagrams, etc.) that support their claim, with an emphasis on <i>how</i> the reasoning supports the claim.</p>	<ul style="list-style-type: none"> <li>▪ Conflicting Contentions</li> <li>▪ Construct an Argument</li> </ul>
<p><b>7.D</b> <i>Provide reasoning to justify a claim using physical principles or laws.</i></p>	<ul style="list-style-type: none"> <li>▪ Explain why your evidence supports your claim, using a transition such as <i>because</i> or <i>therefore</i>.</li> <li>▪ Question your reasoning. Does it make sense? Have you provided a solid explanation of your reasoning?</li> <li>▪ What reasoning (physical principles or laws) supports your claim?</li> <li>▪ How does the reasoning support your claim?</li> </ul>	<p>Have students identify and describe the manner or way in which the reasoning that supports their claim, with an emphasis on <i>how</i> the reasoning supports the claim.</p> <p>Ask students to “close the loop” and explain <i>why</i> the evidence supports their claim by using reasoning.</p>	<ul style="list-style-type: none"> <li>▪ Desktop Experiment</li> <li>▪ Construct an Argument</li> <li>▪ Write and Switch</li> </ul>

*continued on next page*

Skills	Key Questions	Instructional Notes or Sample Activities	Instructional Strategies
<p><b>7.E</b> Explain the connection between experimental results and larger physical principles, laws, or theories.</p>	<ul style="list-style-type: none"> <li>▪ What is the relationship between the experimental results and physical laws, principles, or theories?</li> <li>▪ What connections are there between the experimental results and physical laws, principles, or theories?</li> <li>▪ Is there more than one fundamental physics principle that can be used to support the experimental results?</li> </ul>	<p>Have students practice explaining connections between experimental results and physical principles by having them practice constructing an argument.</p> <p>For example, have students create a short paragraph or set of sentences to explain experimental results, and then have them switch papers to review each other's connections.</p>	<ul style="list-style-type: none"> <li>▪ Qualitative Reasoning</li> <li>▪ Construct an Argument</li> <li>▪ Write and Switch</li> </ul>
<p><b>7.F</b> Explain how potential sources of experimental error may affect results and/or conclusions.</p>	<ul style="list-style-type: none"> <li>▪ What fundamental sources of error exist for the experiment?</li> <li>▪ How can these sources of error be reduced or eliminated?</li> <li>▪ How will each source of error affect the final result of the experiment?</li> </ul>	<p>Have students practice explaining how potential sources of experimental error can affect results by assigning desktop experiment tasks. Present students with a small and simple desktop experiment and ask them to use the apparatus to answer a question and address sources of error.</p>	<ul style="list-style-type: none"> <li>▪ Desktop Experiment</li> <li>▪ Conflicting Contentions</li> <li>▪ Sharing and Responding</li> </ul>

**AP PHYSICS C: ELECTRICITY AND MAGNETISM**

---

# Exam Information

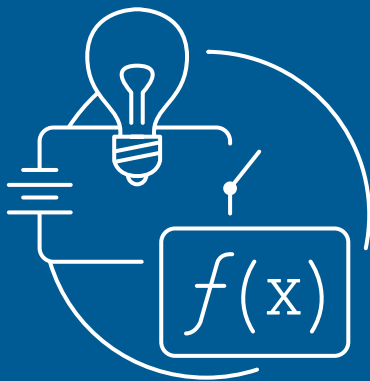

# Exam Overview

---

*The AP Physics C: Electricity and Magnetism Exam assesses student application of the science practices and understanding of the learning objectives outlined in the course framework. The exam is 1 hour and 30 minutes long and includes 35 multiple-choice questions and 3 free-response questions. A four-function, scientific, or graphing calculator is allowed on both sections of the exam. The details of the exam, including exam weighting and timing, can be found below:*

Section	Question Type	Number of Questions	Weighting	Timing
I	Multiple-choice questions	35	50%	45 minutes
II	Free-response questions (15 points each)	3	50%	45 minutes

**The exam assesses content from each of four big ideas for the course:**

**Big Idea 1: Change**

**Big Idea 2: Force Interactions**

**Big Idea 3: Fields**

**Big Idea 4: Conservation**



The exam also assesses each of the five units of instruction with the following weightings on the multiple-choice section of the AP Exam:

### Exam Weighting for the Multiple-Choice Section of the AP Exam

Unit of Instruction	Weighting
<b>Unit 1:</b> Electrostatics	<b>26–34%</b>
<b>Unit 2:</b> Conductors, Capacitors, Dielectrics	<b>14–17%</b>
<b>Unit 3:</b> Electric Circuits	<b>17–23%</b>
<b>Unit 4:</b> Magnetic Fields	<b>17–23%</b>
<b>Unit 5:</b> Electromagnetism	<b>14–20%</b>

# How Student Learning Is Assessed on the AP Exam

---

The AP Physics C: Electricity and Magnetism science practices are assessed on the AP Exam in the multiple-choice and free-response sections as detailed below.

## Section I: Multiple-Choice

Practices 1, 2, 4, 5, 6, and 7 are assessed in the multiple-choice section with the following weightings (Science Practice 3 will not be assessed in the multiple-choice section):

### Exam Weighting for the Multiple-Choice Section of the AP Exam

Science Practice	Exam Weighting
<b>Practice 1:</b> Visual Representations	<b>14–23%</b>
<b>Practice 2:</b> Question and Method	<b>3–6%</b>
<b>Practice 4:</b> Data Analysis	<b>14–17%</b>
<b>Practice 5:</b> Theoretical Relationships	<b>25–32%</b>
<b>Practice 6:</b> Mathematical Routines	<b>14–20%</b>
<b>Practice 7:</b> Argumentation	<b>14–20%</b>

## Section II: Free-Response

All of the Physics C: Electricity and Magnetism science practices are assessed in the free-response section with the following weightings:

### Exam Weighting for the Free-Response Section of the AP Exam

Science Practice	Exam Weighting
<b>Practice 1:</b> Visual Representations	<b>4–9%</b>
<b>Practice 2:</b> Question and Method	<b>6–11%</b>
<b>Practice 3:</b> Representing Data and Phenomena	<b>13–20%</b>
<b>Practice 4:</b> Data Analysis	<b>8–13%</b>
<b>Practice 5:</b> Theoretical Relationships	<b>20–24%</b>
<b>Practice 6:</b> Mathematical Routines	<b>20–24%</b>
<b>Practice 7:</b> Argumentation	<b>11–18%</b>

One of the three free-response questions will include an experimental or lab-based component.

# Task Verbs Used in Free-Response Questions

---

The following task verbs are commonly used in the free-response questions.

**Calculate:** Perform mathematical steps to arrive at a final answer, including algebraic expressions, properly substituted numbers, and correct labeling of units and significant figures. Also phrased as “What is?”

**Compare:** Provide a description or explanation of similarities and/or differences.

**Derive:** Perform a series of mathematical steps using equations or laws to arrive at a final answer.

**Describe:** Provide the relevant characteristics of a specified topic.

**Determine:** Make a decision or arrive at a conclusion after reasoning, observation, or applying mathematical routines (calculations).

**Estimate:** Roughly calculate numerical quantities, values (greater than, equal to, less than), or signs (negative, positive) of quantities based on experimental evidence or provided data. When making estimations, showing steps in calculations are not required.

**Explain:** Provide information about how or why a relationship, process, pattern, position, situation, or outcome occurs, using evidence and/or reasoning to support or qualify a claim. Explain “how” typically requires analyzing the relationship, process, pattern, position, situation, or outcome; whereas, explain “why” typically requires analysis of motivations or reasons for the relationship, process, pattern, position, situation, or outcome.

**Justify:** Provide evidence to support, qualify, or defend a claim, and/or provide reasoning to explain how that evidence supports or qualifies the claim.

**Label:** Provide labels indicating unit, scale, and/or components in a diagram, graph, model, or representation.

**Plot:** Draw data points in a graph using a given scale or indicating the scale and units, demonstrating consistency between different types of representations.

**Sketch/Draw:** Create a diagram, graph, representation, or model that illustrates or explains relationships or phenomena, demonstrating consistency between different types of representations. Labels may or may not be required.

**State/Indicate/Circle:** Indicate or provide information about a specified topic, without elaboration or explanation. Also phrased as “What...?” or “Would...?” interrogatory questions.

**Verify:** Confirm that the conditions of a scientific definition, law, theorem, or test are met in order to explain why it applies in a given situation. Also, use empirical data, observations, tests, or experiments to prove, confirm, and/or justify a hypothesis.

# Sample Exam Questions

---

The following are examples of the kinds of multiple-choice questions found on the exam.

## Section I: Multiple-Choice Questions

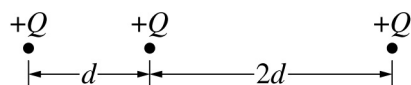

1. Three small spheres of mass  $m$  and positive charge  $Q$  are held in the positions shown in the figure above. The object on the right is then allowed to move and is released from rest. Which of the following claims best describes the subsequent motion of the sphere on the right?
  - (A) The sphere moves to the right with an acceleration that decreases with time.
  - (B) The sphere moves to the right with a constant acceleration.
  - (C) The sphere moves to the right with an acceleration that increases with time.
  - (D) The sphere moves to the left with a constant acceleration.
  - (E) The sphere moves to the left with an acceleration that decreases with time.

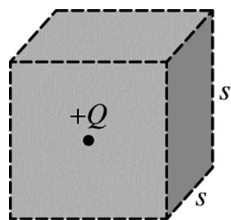

2. A Gaussian cube with sides of length  $s$  encloses a single point charge  $+Q$ . The electric flux through one face of the cube is
  - (A) 0
  - (B)  $\frac{Q}{\epsilon_0}$
  - (C)  $\frac{Q}{6\epsilon_0}$
  - (D)  $\frac{Q}{s^2\epsilon_0}$
  - (E)  $\frac{Q}{6s^2\epsilon_0}$

3. In a region of space, the electric potential  $V_x$  as a function of position  $x$  along an  $x$ -axis is given by the equation  $V_x = Rx - Sx^2$ , where  $R = 3.0 \frac{\text{V}}{\text{m}}$  and  $S = 8.0 \frac{\text{V}}{\text{m}^2}$ . At what point on the  $x$ -axis is the magnitude of the electric field equal to zero?
- (A)  $x = 0.19$  m  
 (B)  $x = 0.38$  m  
 (C)  $x = 0.56$  m  
 (D)  $x = 2.7$  m  
 (E)  $x = 5.3$  m

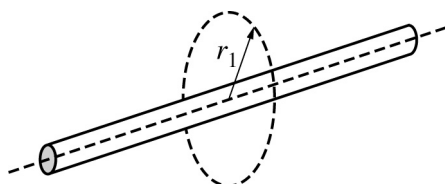

4. The very long rod shown in the figure has a positive charge uniformly distributed along its length. The magnitude of the electric field at a point outside of the rod a distance  $r_0$  from its axis is  $E_0$ . Which of the following is the magnitude of the electric field at a distance  $5r_0$  from the axis of the rod?
- (A)  $\frac{1}{25} E_0$   
 (B)  $\frac{1}{5} E_0$   
 (C)  $E_0$   
 (D)  $5E_0$   
 (E)  $25E_0$

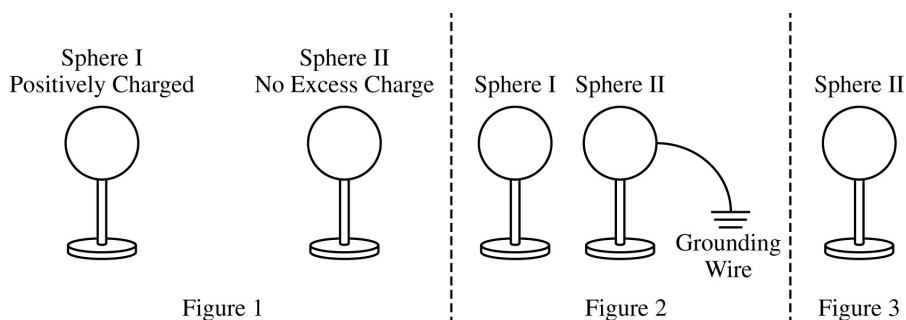

5. Two identical conducting spheres are mounted on insulating handles, as shown. Sphere I has a positive charge, and sphere II has no excess charge, as shown in Figure 1. Sphere I is brought close to sphere II, which is grounded with a wire, as shown in Figure 2. The grounding wire is disconnected and then sphere I is removed, isolating sphere II as shown in Figure 3. Which of the following correctly predicts the charge on sphere II after this procedure is followed?

- (A) Sphere II will have a positive charge.
- (B) Sphere II will have a negative charge.
- (C) Sphere II will have no net charge.
- (D) Sphere II will be polarized, and its left side will have a positive charge.
- (E) Sphere II will be polarized, and its left side will have a negative charge.

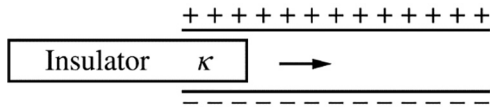

6. A parallel-plate capacitor is fully charged by a battery of voltage  $V$  and then isolated. The magnitude of the charge on each plate is  $Q$ , and the energy stored in the capacitor is  $U$ . A piece of material with dielectric constant  $\kappa = 5$  is inserted between the plates of the capacitor, as shown. The energy stored in the capacitor is now

- (A)  $\frac{1}{2}U$
- (B)  $\frac{1}{5}U$
- (C)  $U$
- (D)  $5U$
- (E)  $25U$

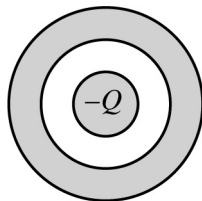

7. A conducting sphere has a charge  $-Q$ , and is surrounded by a concentric spherical conducting sphere that has no net charge. Which of the following best shows the electric field lines in the region of the two spheres?

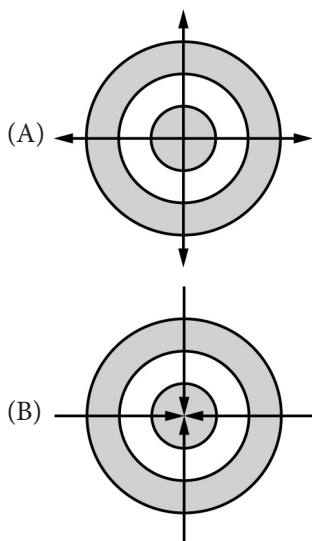

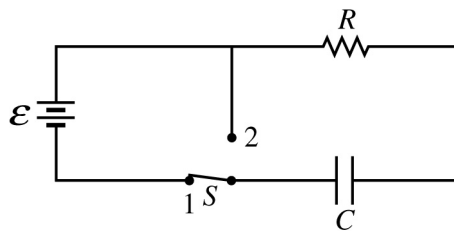
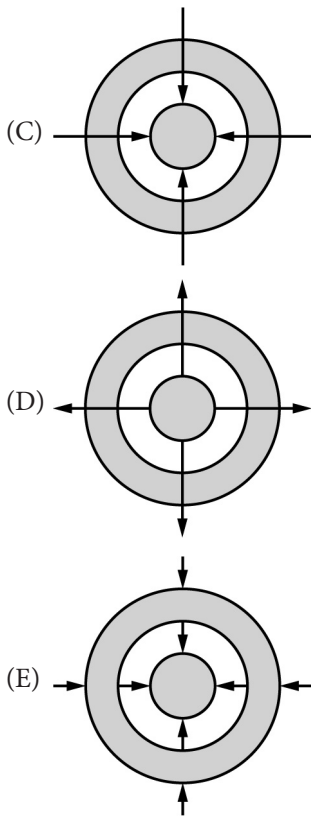

8. In the circuit shown above, the switch  $S$  is initially in position 1. After capacitor  $C$  is fully charged, the switch is moved to position 2 at time  $t = 0$ . Which of the following graphs best represents the current  $I$  as a function of time  $t$  in the resistor  $R$ ?

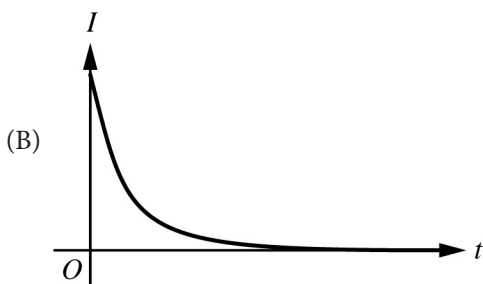
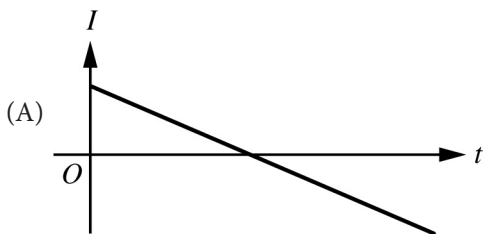



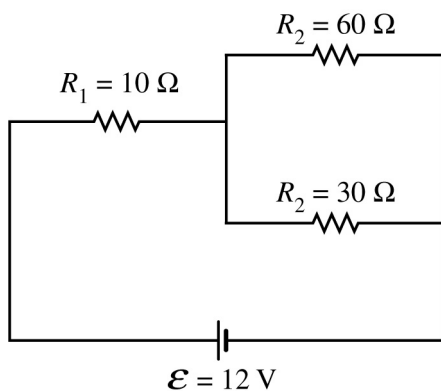
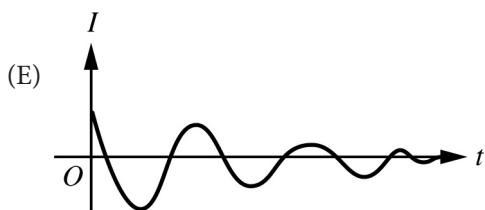
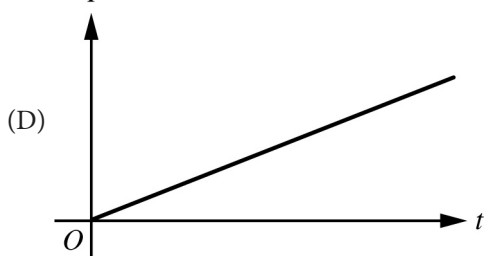
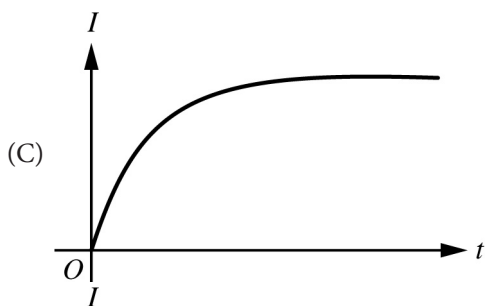

9. In the circuit shown above, the potential difference across  $R_2$  is most nearly
- (A) zero
  - (B) 4.0 V
  - (C) 6.0 V
  - (D) 8.0 V
  - (E) 12 V
10. Resistors 1 and 2 are connected in series to the same battery. The resistors are made of the same material, but resistor 1 has twice the length and half the diameter of resistor 2. If the rate at which energy is dissipated in resistor 2 is  $P$ , what is the rate at which energy is dissipated in resistor 1?

- (A)  $\frac{1}{8}P$
- (B)  $\frac{1}{4}P$
- (C)  $P$
- (D)  $4P$
- (E)  $8P$

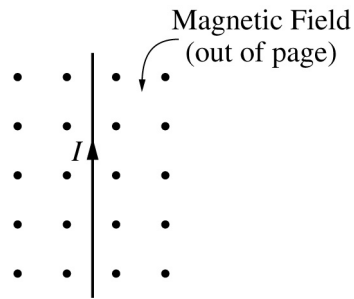

11. A straight wire carrying a current  $I$  is in a uniform magnetic field that is directed out of the page, as shown in the figure. Which of the following best illustrates the direction of the magnetic force on the wire?

- (A)
- (B)
- (C)
- (D)
- (E) zero

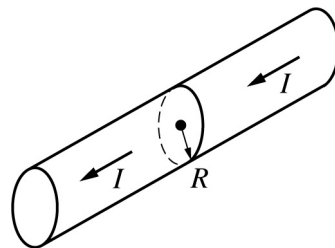

12. The long, straight wire of radius  $R$  carries a current  $I$  that is uniformly distributed over its cross-sectional area. Which of the following graphs best represents the magnitude of the magnetic field  $B$  as a function of distance  $r$  from the axis of the wire?

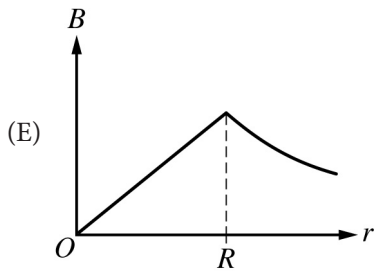
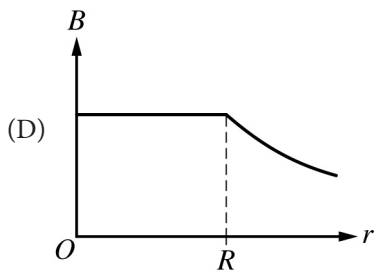
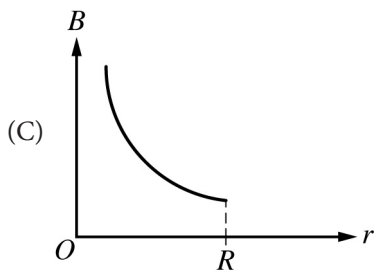
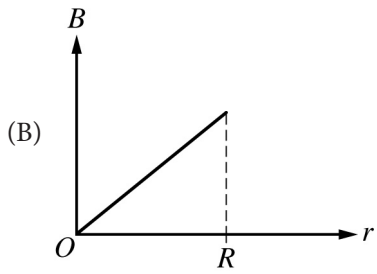
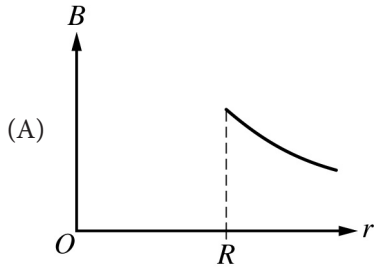

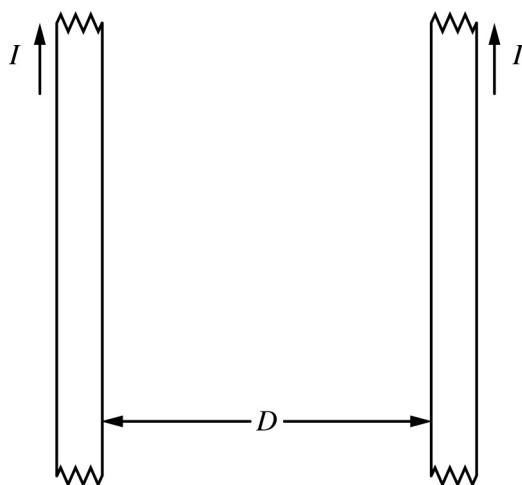

13. Two long, straight, current-carrying wires are parallel to each other in the plane of the page. The wires are a distance  $D$  apart and carry a current  $I$  toward the top of the page, as shown in the figure. Which of the following is a correct expression for the magnetic field midway between the wires?

- (A)  $\frac{4\mu_0 I}{\pi D}$   
 (B)  $\frac{2\mu_0 I}{\pi D}$   
 (C)  $\frac{\mu_0 I}{\pi D}$   
 (D)  $\frac{\mu_0 I}{2\pi D}$   
 (E) Zero

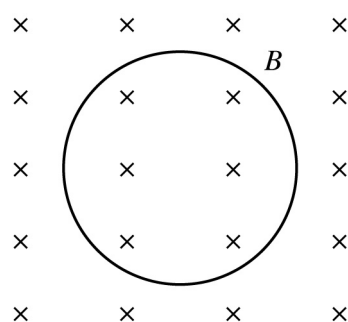

14. The circular wire loop shown above has resistance  $30 \Omega$  and area  $3.0 \text{ m}^2$  and is fixed in position in the plane of the page. A uniform magnetic field of magnitude  $B$  is directed perpendicularly into the plane of the page. The magnetic field begins to decrease, inducing a current of  $1.0 \text{ mA}$  in the loop. The average rate at which the magnitude of the magnetic field is decreasing is most nearly

- (A)  $3.0 \times 10^{-4}$  T/s
- (B)  $1.0 \times 10^{-3}$  T/s
- (C)  $3.0 \times 10^{-3}$  T/s
- (D)  $1.0 \times 10^{-2}$  T/s
- (E)  $3.0 \times 10^{-2}$  T/s

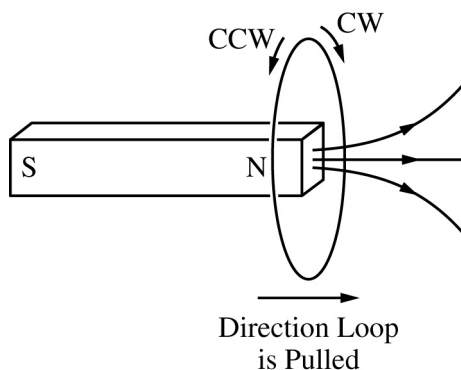

15. Students are performing an experiment with a bar magnet and a conducting loop of wire. The loop is initially around the magnet and is then pulled away from the magnet. At the moment shown in the figure, the loop is being pulled to the right and the students can feel a magnetic force as they pull the loop. Which of the following claims is correct and supported by appropriate experimental evidence?
- (A) There is a clockwise (CW) current induced in the loop, as indicated by a magnetic force to the left.
  - (B) There is a counterclockwise (CCW) current induced in the loop, as indicated by a magnetic force to the left.
  - (C) There is a clockwise (CW) current induced in the loop, as indicated by a magnetic force to the right.
  - (D) There is a counterclockwise (CCW) current induced in the loop, as indicated by a magnetic force to the right.
  - (E) There is a counterclockwise (CCW) current induced in the loop, as indicated by a magnetic force toward the top of the page.

## Section II: Free-Response Questions

The following are examples of the of free-response questions found on the exam. Note that on the actual AP Exam, there will be three questions.

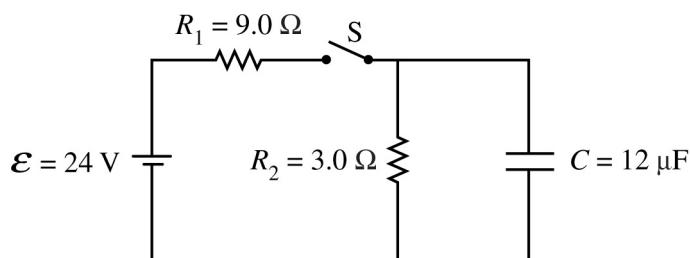

1. A power supply is set to  $\epsilon = 24 \text{ V}$  and is connected to resistors  $R_1 = 9.0 \text{ } \Omega$  and  $R_2 = 3.0 \text{ } \Omega$ , capacitor  $C = 12 \text{ } \mu\text{F}$ , and switch  $S$ , as shown in the figure. Initially, the capacitor is uncharged, and switch  $S$  is open.
  - (a) At time  $t = 0$ , the switch is then closed.
    - i. Calculate the current through  $R_1$  immediately after the switch is closed.
    - ii. Determine the current through  $R_2$  immediately after the switch is closed.

A long time after the switch is closed, the circuit reaches steady-state conditions.
  - (b) Calculate the potential difference across  $R_2$ .
  - (c) Calculate the magnitude of the charge  $Q$  on the positive plate of the capacitor.
  - (d) On the axes shown, sketch a graph of the potential difference  $V_C$  across the capacitor as a function of time  $t$ . Explicitly label any intercepts, asymptotes, maxima, or minima with values or expressions, as appropriate.



After steady-state conditions are reached, the switch is now opened, and time is reset to  $t = 0$ .

- (e) Using integral calculus, derive an expression for the charge  $q(t)$  on the capacitor as a function of time  $t$  after the switch is opened. Express your answer in terms of  $Q$ .

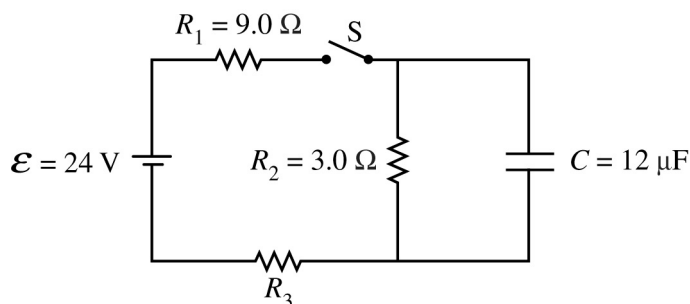

The capacitor is discharged, and a third resistor is added to the circuit, as shown above. The switch is then closed

- (f) Does the time it takes for the charge on the capacitor to reach  $\frac{2}{3}$  of its maximum value increase, decrease, or stay the same as compared to the circuit in part (a)?

\_\_\_\_\_ Increase \_\_\_\_\_ Decrease \_\_\_\_\_ Stay the same

Justify your answer.

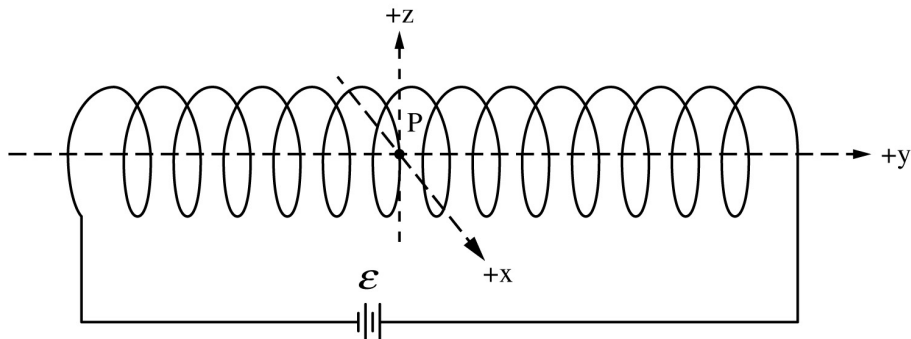

2. A coil of wire is used to create a solenoid as depicted in the figure shown. The right end of the coil goes up in front of the  $y$ -axis, and the left end of the coil goes down behind the  $y$ -axis. The solenoid has radius  $a$ , length  $L$ , and  $N$  turns of wire in its coil. A power supply of variable emf is set to provide a potential difference of  $\epsilon$  and is connected to the solenoid. The figure shows an  $xyz$ -coordinate axis in which the  $y$ -axis is along the central axis of the solenoid and point  $P$  is at the origin of the coordinate system. The resistance of the solenoid is  $R$ .

- (a) Indicate below the direction of the magnetic field at point  $P$ .

\_\_\_\_\_  $+x$  \_\_\_\_\_  $+y$  \_\_\_\_\_  $+z$   
 \_\_\_\_\_  $-x$  \_\_\_\_\_  $-y$  \_\_\_\_\_  $-z$

Justify your answer.

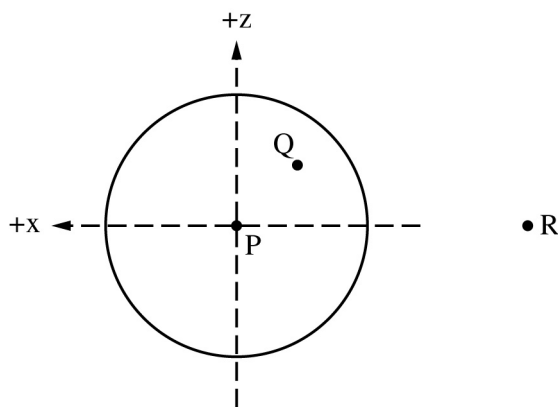

- (b) An axial view of the solenoid is shown. The  $+y$  direction is out of the page. Point P is shown as are two other points, Q and R, which are located with P in the  $xz$  plane. Point Q is a distance  $\frac{1}{2}a$  from point P, and point R is a distance  $4a$  from P.
- Indicate on the figure the directions of the magnetic field at points Q and R. If the magnitude of the magnetic field is zero, indicate this by writing  $B = 0$  next to that point.
  - Is the magnitude of the magnetic field at point Q greater than, less than, or equal to the magnitude of the magnetic field at point P?  
 \_\_\_\_\_ Greater than \_\_\_\_\_ Less than \_\_\_\_\_ Equal to

Justify your answer.

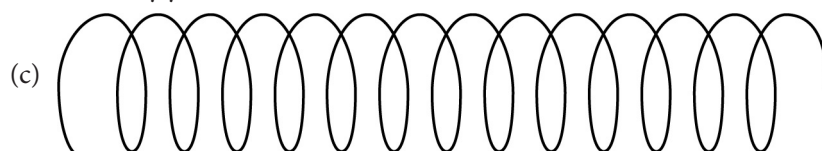

- On the figure above, draw an Amperian loop that can be used to determine the magnetic field along the central axis of the solenoid.
- Use Ampere's law to derive an expression for the magnetic field strength at point P. Express your answer in terms of  $\epsilon$ ,  $R$ ,  $L$ ,  $N$ ,  $a$ , and physical constants, as appropriate.

Students conduct an experiment with this apparatus in which they vary the emf of the power supply and measure the resulting magnetic field strength at the center of the solenoid. The data are shown in the table. The students also note that the solenoid has 160 turns, the radius  $a = 0.015$  m, and the length  $L = 0.140$  m.

$\epsilon$ (V)	1.48	2.94	4.36	5.81	7.31
$B(10^{-5} \text{ T})$	4.7	10.7	13.7	20.4	24.9

- (d) Plot these data on the axes provided and draw a best-fit line for the data.



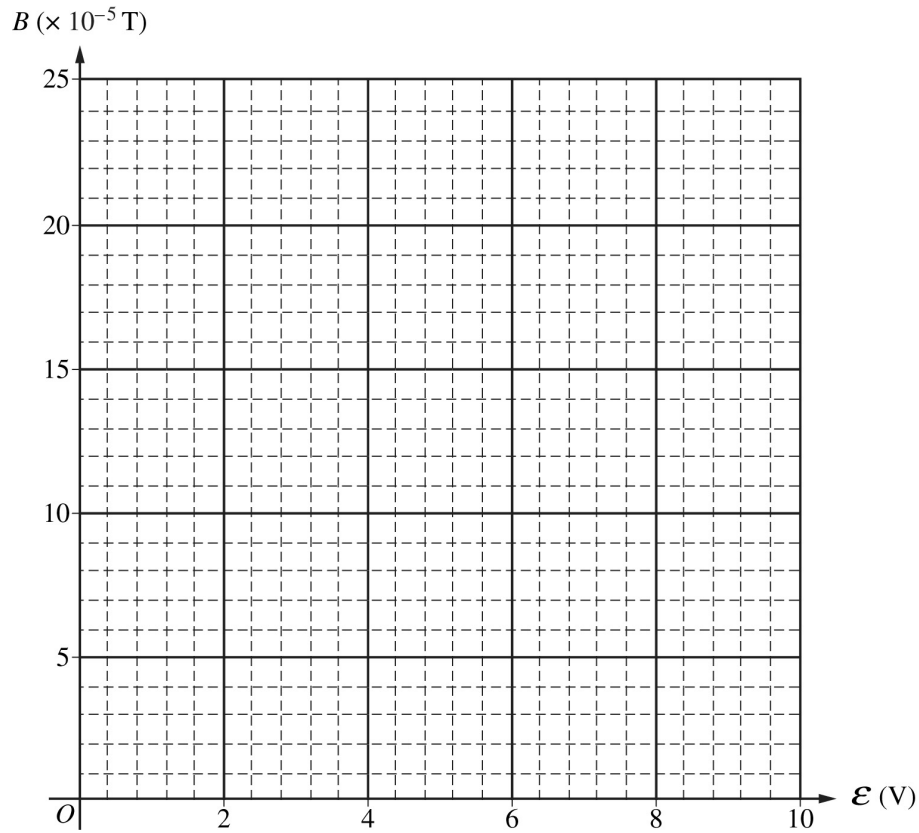

(e) Use the best-fit line to calculate the resistance of the circuit used in the experiment.

A resistor is added in parallel with the solenoid.

(f) Will the magnetic field on the central axis of the solenoid increase, decrease, or stay the same?

\_\_\_\_\_ Increase \_\_\_\_\_ Decrease \_\_\_\_\_ Stay the same

Justify your answer.

# Answer Key and Question Alignment to Course Framework

Multiple-Choice Question	Answer	Skill	Learning Objective	Unit
1	A	7.A	ACT-1.D	1
2	C	5.D	CNV-2.B	1
3	A	6.C	CNV-1.G	1
4	B	5.C	CNV-3.A	1
5	B	2.B	ACT-2.C	1
6	B	5.C	FIE-2.D	2
7	E	1.C	ACT-2.A	2
8	B	4.A	CNV-7.D	3
9	D	6.B	CNV-6.C	3
10	A	5.C	CNV-5.B	3
11	A	1.D	FIE-4.A	4
12	E	4.A	FIE-5.A	4
13	E	5.D	FIE-5.B	4
14	D	6.A	FIE-6.A	5
15	B	7.C	ACT-4.A	5

Free-Response Question	Skill	Learning Objective	Unit
1	3.C, 5.A, 6.B, 6.C, 7.A, 7.D	CNV-6.C, CNV-7.B, CNV-7.C, CNV-7.D, CNV-7.E	3
2	3.A, 3.D, 4.C, 4.D, 5.A, 5.D, 6.C, 7.A, 7.D	CNV-8.C	4

The scoring information for the questions within this course and exam description, along with further exam resources, can be found on the [AP Physics C: Electricity and Magnetism Exam Page](#) on AP Central.

THIS PAGE IS INTENTIONALLY LEFT BLANK.

**AP PHYSICS C: ELECTRICITY AND MAGNETISM**

---

# Appendix

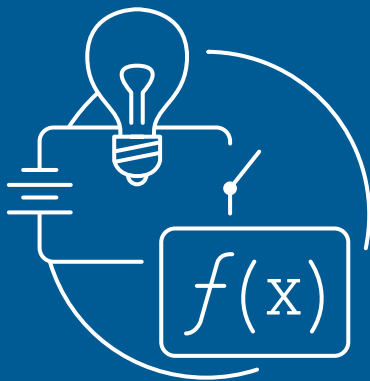

**AP PHYSICS C: ELECTRICITY  
AND MAGNETISM**

**Table of  
Information:  
Equations**

## ADVANCED PLACEMENT PHYSICS C TABLE OF INFORMATION

CONSTANTS AND CONVERSION FACTORS	
Proton mass, $m_p = 1.67 \times 10^{-27}$ kg Neutron mass, $m_n = 1.67 \times 10^{-27}$ kg Electron mass, $m_e = 9.11 \times 10^{-31}$ kg Avogadro's number, $N_0 = 6.02 \times 10^{23}$ mol <sup>-1</sup> Universal gas constant, $R = 8.31$ J/(mol·K) Boltzmann's constant, $k_B = 1.38 \times 10^{-23}$ J/K	Electron charge magnitude, $e = 1.60 \times 10^{-19}$ C 1 electron volt, $1 \text{ eV} = 1.60 \times 10^{-19}$ J Speed of light, $c = 3.00 \times 10^8$ m/s Universal gravitational constant, $G = 6.67 \times 10^{-11}$ (N·m <sup>2</sup> )/kg <sup>2</sup> Acceleration due to gravity at Earth's surface, $g = 9.8$ m/s <sup>2</sup>
1 unified atomic mass unit, Planck's constant, Vacuum permittivity, Coulomb's law constant, $k = 1/(4\pi\epsilon_0) = 9.0 \times 10^9$ (N·m <sup>2</sup> )/C <sup>2</sup> Vacuum permeability, Magnetic constant, $k' = \mu_0/(4\pi) = 1 \times 10^{-7}$ (T·m)/A 1 atmosphere pressure,	$1 \text{ u} = 1.66 \times 10^{-27}$ kg = 931 MeV/c <sup>2</sup> $h = 6.63 \times 10^{-34}$ J·s = $4.14 \times 10^{-15}$ eV·s $hc = 1.99 \times 10^{-25}$ J·m = $1.24 \times 10^3$ eV·nm $\epsilon_0 = 8.85 \times 10^{-12}$ C <sup>2</sup> /(N·m <sup>2</sup> ) $\mu_0 = 4\pi \times 10^{-7}$ (T·m)/A $1 \text{ atm} = 1.0 \times 10^5$ N/m <sup>2</sup> = $1.0 \times 10^5$ Pa

UNIT SYMBOLS	meter, m	mole, mol	watt, W	farad, F
	kilogram, kg	hertz, Hz	coulomb, C	tesla, T
	second, s	newton, N	volt, V	degree Celsius, °C
	ampere, A	pascal, Pa	ohm, Ω	electron volt, eV
	kelvin, K	joule, J	henry, H	

PREFIXES		
Factor	Prefix	Symbol
10 <sup>9</sup>	giga	G
10 <sup>6</sup>	mega	M
10 <sup>3</sup>	kilo	k
10 <sup>-2</sup>	centi	c
10 <sup>-3</sup>	milli	m
10 <sup>-6</sup>	micro	μ
10 <sup>-9</sup>	nano	n
10 <sup>-12</sup>	pico	p

VALUES OF TRIGONOMETRIC FUNCTIONS FOR COMMON ANGLES							
$\theta$	0°	30°	37°	45°	53°	60°	90°
$\sin \theta$	0	1/2	3/5	$\sqrt{2}/2$	4/5	$\sqrt{3}/2$	1
$\cos \theta$	1	$\sqrt{3}/2$	4/5	$\sqrt{2}/2$	3/5	1/2	0
$\tan \theta$	0	$\sqrt{3}/3$	3/4	1	4/3	$\sqrt{3}$	∞

The following assumptions are used in this exam.

- I. The frame of reference of any problem is inertial unless otherwise stated.
- II. The direction of current is the direction in which positive charges would drift.
- III. The electric potential is zero at an infinite distance from an isolated point charge.
- IV. All batteries and meters are ideal unless otherwise stated.
- V. Edge effects for the electric field of a parallel plate capacitor are negligible unless otherwise stated.

## ADVANCED PLACEMENT PHYSICS C EQUATIONS

MECHANICS	ELECTRICITY AND MAGNETISM
$v_x = v_{x0} + a_x t$ $x = x_0 + v_{x0} t + \frac{1}{2} a_x t^2$ $v_x^2 = v_{x0}^2 + 2a_x(x - x_0)$ $\vec{a} = \frac{\sum \vec{F}}{m} = \frac{\vec{F}_{net}}{m}$ $\vec{F} = \frac{d\vec{p}}{dt}$ $\vec{J} = \int \vec{F} dt = \Delta\vec{p}$ $\vec{p} = m\vec{v}$ $ \vec{F}_f  \leq \mu  \vec{F}_N $ $\Delta E = W = \int \vec{F} \cdot d\vec{r}$ $K = \frac{1}{2} m v^2$ $P = \frac{dE}{dt}$ $P = \vec{F} \cdot \vec{v}$ $\Delta U_g = mg\Delta h$ $a_c = \frac{v^2}{r} = \omega^2 r$ $\vec{\tau} = \vec{r} \times \vec{F}$ $\vec{\alpha} = \frac{\sum \vec{\tau}}{I} = \frac{\vec{\tau}_{net}}{I}$ $I = \int r^2 dm = \sum mr^2$ $x_{cm} = \frac{\sum m_i x_i}{\sum m_i}$ $v = r\omega$ $\vec{L} = \vec{r} \times \vec{p} = I\vec{\omega}$ $K = \frac{1}{2} I\omega^2$ $\omega = \omega_0 + \alpha t$ $\theta = \theta_0 + \omega_0 t + \frac{1}{2} \alpha t^2$	$a = \text{acceleration}$ $E = \text{energy}$ $F = \text{force}$ $f = \text{frequency}$ $h = \text{height}$ $I = \text{rotational inertia}$ $J = \text{impulse}$ $K = \text{kinetic energy}$ $k = \text{spring constant}$ $\ell = \text{length}$ $L = \text{angular momentum}$ $m = \text{mass}$ $P = \text{power}$ $p = \text{momentum}$ $r = \text{radius or distance}$ $T = \text{period}$ $t = \text{time}$ $U = \text{potential energy}$ $v = \text{velocity or speed}$ $W = \text{work done on a system}$ $x = \text{position}$ $\mu = \text{coefficient of friction}$ $\theta = \text{angle}$ $\tau = \text{torque}$ $\omega = \text{angular speed}$ $\alpha = \text{angular acceleration}$ $\phi = \text{phase angle}$ $\vec{F}_s = -k\Delta\vec{x}$ $U_s = \frac{1}{2} k (\Delta x)^2$ $x = x_{\max} \cos(\omega t + \phi)$ $T = \frac{2\pi}{\omega} = \frac{1}{f}$ $T_s = 2\pi\sqrt{\frac{m}{k}}$ $T_p = 2\pi\sqrt{\frac{\ell}{g}}$ $ \vec{F}_G  = \frac{Gm_1 m_2}{r^2}$ $U_G = -\frac{Gm_1 m_2}{r}$
	$ \vec{F}_E  = \frac{1}{4\pi\epsilon_0} \left  \frac{q_1 q_2}{r^2} \right $ $\vec{E} = \frac{\vec{F}_E}{q}$ $\oint \vec{E} \cdot d\vec{A} = \frac{Q}{\epsilon_0}$ $E_x = -\frac{dV}{dx}$ $\Delta V = -\int \vec{E} \cdot d\vec{r}$ $V = \frac{1}{4\pi\epsilon_0} \sum_i \frac{q_i}{r_i}$ $U_E = qV = \frac{1}{4\pi\epsilon_0} \frac{q_1 q_2}{r}$ $\Delta V = \frac{Q}{C}$ $C = \frac{\kappa\epsilon_0 A}{d}$ $C_p = \sum_i C_i$ $\frac{1}{C_s} = \sum_i \frac{1}{C_i}$ $I = \frac{dQ}{dt}$ $U_C = \frac{1}{2} Q\Delta V = \frac{1}{2} C(\Delta V)^2$ $R = \frac{\rho\ell}{A}$ $\vec{E} = \rho\vec{J}$ $I = Nev_d A$ $I = \frac{\Delta V}{R}$ $R_s = \sum_i R_i$ $\frac{1}{R_p} = \sum_i \frac{1}{R_i}$ $P = I\Delta V$
	$A = \text{area}$ $B = \text{magnetic field}$ $C = \text{capacitance}$ $d = \text{distance}$ $E = \text{electric field}$ $\mathcal{E} = \text{emf}$ $F = \text{force}$ $I = \text{current}$ $J = \text{current density}$ $L = \text{inductance}$ $\ell = \text{length}$ $n = \text{number of loops of wire per unit length}$ $N = \text{number of charge carriers per unit volume}$ $P = \text{power}$ $Q = \text{charge}$ $q = \text{point charge}$ $R = \text{resistance}$ $r = \text{radius or distance}$ $t = \text{time}$ $U = \text{potential or stored energy}$ $V = \text{electric potential}$ $v = \text{velocity or speed}$ $\rho = \text{resistivity}$ $\Phi = \text{flux}$ $\kappa = \text{dielectric constant}$ $\vec{F}_M = q\vec{v} \times \vec{B}$ $\oint \vec{B} \cdot d\vec{\ell} = \mu_0 I$ $d\vec{B} = \frac{\mu_0}{4\pi} \frac{I d\vec{\ell} \times \hat{r}}{r^2}$ $\vec{F} = \int I d\vec{\ell} \times \vec{B}$ $B_s = \mu_0 n I$ $\Phi_B = \int \vec{B} \cdot d\vec{A}$ $\mathcal{E} = \oint \vec{E} \cdot d\vec{\ell} = -\frac{d\Phi_B}{dt}$ $\mathcal{E} = -L \frac{dI}{dt}$ $U_L = \frac{1}{2} L I^2$



## ADVANCED PLACEMENT PHYSICS C EQUATIONS

### GEOMETRY AND TRIGONOMETRY

Rectangle

$$A = bh$$

Triangle

$$A = \frac{1}{2}bh$$

Circle

$$A = \pi r^2$$

$$C = 2\pi r$$

$$s = r\theta$$

Rectangular Solid

$$V = \ell wh$$

Cylinder

$$V = \pi r^2 \ell$$

$$S = 2\pi r \ell + 2\pi r^2$$

Sphere

$$V = \frac{4}{3}\pi r^3$$

$$S = 4\pi r^2$$

Right Triangle

$$a^2 + b^2 = c^2$$

$$\sin \theta = \frac{a}{c}$$

$$\cos \theta = \frac{b}{c}$$

$$\tan \theta = \frac{a}{b}$$

$A$  = area

$C$  = circumference

$V$  = volume

$S$  = surface area

$b$  = base

$h$  = height

$\ell$  = length

$w$  = width

$r$  = radius

$s$  = arc length

$\theta$  = angle

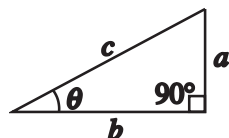
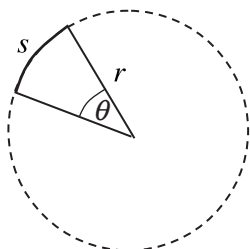

### CALCULUS

$$\frac{df}{dx} = \frac{df}{du} \frac{du}{dx}$$

$$\frac{d}{dx}(x^n) = nx^{n-1}$$

$$\frac{d}{dx}(e^{ax}) = ae^{ax}$$

$$\frac{d}{dx}(\ln ax) = \frac{1}{x}$$

$$\frac{d}{dx}[\sin(ax)] = a \cos(ax)$$

$$\frac{d}{dx}[\cos(ax)] = -a \sin(ax)$$

$$\int x^n dx = \frac{1}{n+1} x^{n+1}, n \neq -1$$

$$\int e^{ax} dx = \frac{1}{a} e^{ax}$$

$$\int \frac{dx}{x+a} = \ln|x+a|$$

$$\int \cos(ax) dx = \frac{1}{a} \sin(ax)$$

$$\int \sin(ax) dx = -\frac{1}{a} \cos(ax)$$

### VECTOR PRODUCTS

$$\vec{A} \cdot \vec{B} = AB \cos \theta$$

$$|\vec{A} \times \vec{B}| = AB \sin \theta$$

