



REQUEST FOR QUOTATION

**South Eugene High School Softball Scoreboard Installation 2016**

EUGENE PUBLIC SCHOOL DISTRICT 4J

EUGENE, OREGON

Return by: Friday, December 9  
2:00 PM  
No faxed or electronic quotes will be accepted.

Mailing Address: Facilities Management  
715 West 4th Avenue  
Eugene, Oregon 97402  
Phone: (541) 790- 7400

Michael Heffernan, AIA  
District Architect

DATE ISSUED:  
Nov. 22, 2016



SECTION 00 01 10  
TABLE OF CONTENTS  
SEHS SOFTBALL SCOREBOARD INSTALLATION 2016  
NOVEMBER 22, 2016

The following is a list of all Divisions, Sections, and Drawings which are included in the Request for Quotation

<b>INTRODUCTORY PAGES</b>		<b>PAGES</b>
	Cover	1
Section 00 01 10	Table of Contents	1
 <b>QUOTATION REQUIREMENTS</b>		
Section 00 11 13	Request for Quotations	1
Section 00 21 13	Quotation Requirements	2
Section 00 30 00	Quotation Form	4
 <b>CONTRACT DOCUMENTS</b>		
Section 00 50 00	Construction Contract Agreement	1
Section 00 50 10	Terms and Conditions	7
Section 00 73 43	Prevailing Wage Rates (June 1, 2016 version)	1
 <b>DIVISION 01      GENERAL REQUIREMENTS</b>		
Section 01 11 00	Summary of Work	6
Section 01 40 00	Quality Requirements	2
Section 01 60 00	Product Requirements (Substitution Request Form)	5
Section 01 77 00	Closeout Submittals	3
 <b>DRAWINGS</b>		
Sheet A1	Site Plan	1
Sheet A2	Enlarged Project Location Plan	1
Sheet S1	Plan, Elevation & support Details	1

**REQUEST FOR QUOTATIONS  
SECTION 00 11 13**

Sealed Quotes will be received by Kathi Hernandez, Purchasing Services, for SEHS Softball Scoreboard Installation until 2:00 pm, December 9, 2016 at the Eugene School District Facilities Management Office, 715 West Fourth, Eugene, Oregon 97402.

Briefly, the work is described Project consists of installing owner provided scoreboard & steel columns in concrete piers as well as extending existing conduit to the scoreboard.

All quotations must be submitted on the form provided and enclosed in a sealed envelope marked:

*South Eugene High School Softball Scoreboard Installation 2016*

**No faxed or electronic quotes will be accepted.**

A Non-Mandatory Pre-Quote meeting will be held on Monday, December 5, at 2:00pm at South Eugene High School, 400 E. 19<sup>th</sup> Ave. Eugene, Oregon, 97401. Meeting will begin at the front office.

No Quote for a construction contract will be received or considered unless the Contractor is registered with the Construction Contractors Board or licensed by the State Landscape Contractors Board at the time of the bid as required by ORS 671.530. A license to work with asbestos-containing materials under ORS 468A.720 is not required for this Project.

Each Quote shall contain a statement indicating whether the Quoter is a “resident quoter”, as defined in ORS 279A.120.

Each Quote shall contain a statement that the “Contractor agrees to be bound by and comply with the provisions of ORS 279C.800 to 279C.870 regarding payment of Prevailing Wages”.

Contractor shall certify nondiscrimination in obtaining required subcontractors, in accordance with ORS 279A.110(4).

The successful Quoter will be required to furnish a Performance Bond and Labor and Materials Payment Bond each in the full amount of the contract price. Certificates of Insurance as described in the Terms and Conditions will be required.

Each Quote must be submitted on the prescribed form. Each Quote shall be accompanied by a surety bond, cashiers check, or certified check, executed in favor of Eugene School District 4J, in the amount not less than ten percent (10%) of the total Quote, based upon the total Quote amount for those items Quoted upon. Should the Quoter refuse to enter into such Contract or fail to furnish Certificates of Insurance as required by the Supplementary Conditions within ten (10) working days after contract forms are provided to the Quoter, the amount of the Quote Security shall be forfeited to the Owner as liquidated damages, not as a penalty.

School District 4J reserves the right to reject any and all proposals received as a result of this request for Quotations and select the Quote which appears to be in the best interest of the District.

Today’s Date:	November 22, 2016
Quotes due:	December 9, 2017
Substantial Completion:	February 15, 2017

By: Michael Heffernan, AIA  
District Architect

**QUOTATION REQUIREMENTS  
SECTION 00 21 13**

**PART 1 GENERAL**

**1.1. GENERAL INFORMATION**

- A. The term “quoter” shall refer to the firm or individual submitting a quote or quotation.
- B. Quoters are encouraged to visit the site(s) to become familiar with existing conditions. The Owner is not responsible and shall not bear financial burden for oversights made by the Quoter for failure to inspect sites prior to submitting a quote.
- C. In all cases, persons wishing to examine the area of work must sign in at the school office prior to visiting the work area. Prior to leaving the school, sign-out at the office is required.
- D. If access is required at times when the school office is not staffed, contact the Facilities Office, (571) 790-7417, for assistance.
- E. The Owner is excise tax exempt. "Goods used hereon are for the exclusive use of this School District." Excise exemption No. 93 740074 F.

**1.2. QUOTE PROCEDURES**

- A. Quotes are to be submitted in one copy on the forms provided.
- B. Quoters shall certify to non-collusion practices on the form included as part of the Quote Form, to be submitted with the Quote Form.
  - 1. A Non-Collusion Affidavit is required for any contract awarded pursuant to the quote. According to the Oregon Public Contracts and Purchasing Laws, a public contracting agency may reject any or all quotes upon a finding of the agency that it is in the public interest to do so (ORS 279C.395). This agency finds that it is in the public interest to require the completion of this affidavit by potential contractors.
  - 2. The Non-Collusion Affidavit must be executed by the member, officer or employee of the quoter who makes the final decision on prices and the amount quoted in the quote.
  - 3. Quote rigging and other efforts to restrain competition, and the making of false sworn statements in connection with the submission of quotes are unlawful and may be subject to criminal prosecution. The person who signs the Affidavit should examine it carefully before signing and assure himself or herself that each statement is true and accurate, making diligent inquiry, as necessary, of all other persons employed by or associated with the quoter with responsibilities for the preparation, approval or submission of the quote.
  - 4. In the case of a quote submitted by a joint venture, each party to the venture must be identified in the quote documents, and an Affidavit must be submitted separately on behalf of each party.
  - 5. The term "complementary quote" as used in the Affidavit has the meaning commonly associated with the term in the quoting process, and includes the knowing submission of quotes higher than the quote of another firm, any intentionally high or noncompetitive quote, and any other form of quote submitted for the purpose of giving a false appearance of competition.
  - 6. Failure to file an Affidavit in compliance with these instructions will result in disqualification of the quote.
- C. Quoters shall certify to non-discrimination in employment practices on the form, included as part of the Quote Form, to be submitted with the Quote Form. By submitting its quote, the Quoter certifies conformance to the applicable federal acts, executive orders, and Oregon statutes and regulations concerning affirmative action toward equal employment opportunities. All information and reports required by the federal or Oregon state governments having responsibility for the enforcement of such laws shall be supplied to the Owner in compliance with such acts, regulation, and orders.
- D. Quoter shall indicate, on the Quote Form where provided, the quoter status as a "resident" or "non-resident" in accordance with ORS 279A.120 and ORS 279C.365.

- E. A Quote may not be withdrawn or canceled by the Quoter following the time and date designated for the receipt of quotes to the expiration of a 60 day period. The Quote for that sixty days is irrevocable and each Quoter so agrees in submitting a Quote.

### **1.3. Quote Security**

- A. Each Quote shall be accompanied by a surety bond, cashiers check, or certified check, executed in favor of Eugene School District 4J, in the amount not less than ten percent (10%) of the total Quote, based upon the total Quote amount for those items Quote upon. Should the Quoter refuse to enter into such Contract or fail to furnish Performance and Labor and Materials Payment Bonds and Certificates of Insurance as required by the Supplementary Conditions within ten (10) working days after contract forms are provided to the Quoter, the amount of the Quote Security may be forfeited to the Owner as liquidated damages, not as a penalty.
  - 1 The Surety Bond shall be written by a Bonding Company authorized and licensed by the Oregon Insurance Commissioner. The bonding company must be listed on the most current US Government Treasury List, Department Circular 570, or approved PRIOR TO QUOTE SUBMISSION by the Eugene School District 4J's Risk Manager. The Bond shall be on a AIA Document A310, most current edition. The Attorney-in-Fact who executes the Bond on behalf of the Surety shall affix to the Bond, a certified copy of a power of attorney.
  - 2. The Owner will have the right to retain the Quote Security of Quoters until either; a) the Contract has been executed and Bonds have been furnished, or b) the specified time has elapsed so that Quotes may be withdrawn, or c) all Quotes have been rejected.

### **1.4. PERFORMANCE BOND AND PAYMENT BOND**

- A. Unless otherwise stated in the solicitation document, the successful Quoter shall be required to provide the Owner with a Performance Bond and Labor and Material Payment Bond each in an amount equal to one hundred (100%) of the contract sum. The Surety Company shall meet requirements as specified in the Supplementary Conditions.
- B. The Labor and Material Payment Bond shall contain a clause specifically guaranteeing payment of all sums of money withheld from employees and payable to the Internal Revenue Service; and all contributions or amounts due to the State of Oregon from the General Contractor or subcontractor incurred in the performance of this contract.
- C. The Bond shall be fully executed, payable to the Owner.
- D. The cost of these bonds shall be included in the Quote.
- E. The successful Quoter will be provided with contract forms through the Architect. These forms shall be executed and delivered to the Owner, along with Performance Bond and Labor and Material Payment Bond, within ten (10) days after receiving forms.

### **1.5. SUBSTITUTION REQUESTS**

- A. Submit request for substitution for review and approval by Owner, for entire system as specified. Requests must arrive at School District 4J facilities Office no later than 5 days prior to Quote opening. Requests submitted after that time will be rejected. A Memorandum will be issued min 1 day before Quote opening if any Substitution Requests are accepted. Submittal of substitution requests shall include manufacturers product data and brochures as back up information for review. All systems components must be included in Submittal for approval. Submit requests on form included in this Request for Quotes.

### **1.6. ADMINISTRATIVE RULES**

- A. All quoters are required to comply with the provisions of Oregon Revised Statutes and 4J Board Policy. Attention is directed to ORS 244, Government Ethics; ORS 279A and 279C, Public Contracting Code; Oregon Administrative Rules, Chapter 137, Divisions 46, 48 and 49; and 4J Board Policy DJC.

### **1.7. PROTEST OF QUOTE**

- A. Protests of quote specifications or contract terms shall be presented to the Owner in writing five (5) calendar days prior to quote opening. Such protest or request for change shall include the reason for protest or request, and any proposed changes to specifications or terms. No protest against award because of the content of quote specifications or contract terms shall be considered after the deadline established for submitting such protest.

**1.8. PROTEST OF AWARD**

- A. Any actual quoter or proposer who is adversely affected by the Owner's notice of award of the contract to another quoter or proposer on the same solicitation shall have seventy-two (72) hours from the notice of award to submit to the Owner, a written protest of the notice of award. In order to be an adversely affected or aggrieved quoter or proposer with a right to submit a written protest, a quoter or proposer must itself claim to be eligible for award of the contract as the lowest responsible quoter or best proposer and must be next in line for award.

**1.9. FINAL AWARD**

- A. The written notice of award of the contract shall constitute a final decision of the Owner to award the contract if no written protest of the notice of award is filed with the Owner within the designated time.

END OF QUOTE REQUIREMENTS

**QUOTATION FORM  
SECTION 00 30 00**

Proposal for: South Eugene High School Softball Scoreboard Installation 2016

Submitted to: Facilities Management Office  
Eugene School District No. 4J  
715 West Fourth Avenue  
Eugene, Oregon 97402

Due Date: December 9, 2016  
Time: 2:00 pm

From: \_\_\_\_\_  
(Company Name)

The undersigned proposes to furnish all material, equipment, and labor required for the complete project, and to perform all work in strict accordance with the Contract Documents for the lump sum price indicated below.

BASE QUOTE:

Quote Amount: \_\_\_\_\_ \$ \_\_\_\_\_  
(Words) (Figures)

**QUOTE SECURITY**

Accompanying herewith is Quote Security, which is not less than ten percent (10%) of the total amount of the Base Quote.

The undersigned agrees, if awarded the Contract, to substantially complete all Base Quote work on or before the dates specified in Section 01 11 00.

The undersigned agrees, if awarded the contract, to comply with the provisions of Oregon Revised Statutes 279C.800 through 279C.870 pertaining to the payment of prevailing rates of wage.

The undersigned agrees, if awarded the Contract, to execute and deliver to the Owner within ten (10) working days after receiving contract forms, an Agreement and a satisfactory Performance Bond and a Labor and Material Payment Bond, if required elsewhere in the solicitation, each in an amount equal to 100 percent (100%) of the Contract Sum.

The undersigned has received addenda numbers \_\_\_\_\_ to \_\_\_\_\_ inclusive and has included their provisions in the above Quote amount.

By submitting this Quote, the Quoter certifies that the Quoter:

a) has available the appropriate financial, material, equipment, facility and personnel resources and expertise, or the ability to obtain the resources and expertise, necessary to meet all contractual responsibilities; b) has a satisfactory record of past performance; c) has a satisfactory record of integrity, and is not disqualified under ORS 279C.440; d) is qualified legally to contract with the Owner; and e) will promptly supply all necessary information in connection with any inquiry the Owner may make concerning the responsibility of the Quoter. Prior to award of a Contract, the Quoter shall submit appropriate documentation to allow the Owner to determine whether or not the Quoter is "responsible" according to the above criteria.

Contractor warrants that Contractor has a Qualifying Employee Drug-Testing program and will require each subcontractor providing labor for the project to do the same.

The undersigned agrees if awarded the contract to comply with Oregon Revised Statutes 326.603 giving the Owner authority to obtain fingerprints and criminal records check of Contractors, their employees, and subcontractors providing labor for the Project.

The undersigned has visited the site to become familiar with conditions under which the Work is to be performed and has correlated the Quoter's personal observations with the requirements of the proposed Contract Documents.

The undersigned certifies that the Quoter is a \_\_\_\_\_ Quoter under ORS. ("Resident" or "Non-resident", to be filled in by Quoter).

Names of Firm: \_\_\_\_\_

Street Address: \_\_\_\_\_  
(City) (State) (Zip)

Telephone Number: \_\_\_\_\_ Fax Number: \_\_\_\_\_ E-Mail: \_\_\_\_\_

Signed By: \_\_\_\_\_ Printed Name: \_\_\_\_\_  
(Signature of Authorized Official. If Firm is a partnership, one of the partners must sign quote).

Official Capacity: \_\_\_\_\_

If corporation, attest: \_\_\_\_\_ Date: \_\_\_\_\_  
(Secretary of Corporation)

SEAL (If Corporation) \_\_\_\_\_ Corporation  
\_\_\_\_\_ Partnership  
\_\_\_\_\_ Individual

Enclosed: Quote Security



**NON-DISCRIMINATION REQUIREMENT**

Contractor certifies that the Contractor has not discriminated against minorities, women or emerging small business enterprises in obtaining any required subcontracts.

The Contractor agrees not to discriminate against any client, employee or applicant for employment or for services, because of race, color, religion, sex, national origin, physical or mental handicap, sexual orientation or age unless based upon bona fide occupational qualifications, and that they are otherwise in compliance with all federal, state and local laws prohibiting discrimination, with regard to, but not limited to, the following: Employment upgrading, demotion or transfer; Recruitment or recruitment advertising; Layoffs or termination; Rates of pay or other forms of compensation; Selection for training; Rendition of services. It is further understood that any vendor who is in violation of this clause shall be barred forthwith from receiving awards of any purchase order from the School District, unless a satisfactory showing is made that discriminatory practices have terminated and that a recurrence of such acts is unlikely.

BY \_\_\_\_\_ (Company or Firm Officer) \_\_\_\_\_ (Type or Print Name)

**NON-COLLUSION AFFIDAVIT**

STATE OF \_\_\_\_\_

County of \_\_\_\_\_

I state that I am \_\_\_\_\_ of \_\_\_\_\_ and that  
(Title) (Name of Firm)

I am authorized to make this affidavit on behalf of my firm, and its owners, directors, and officers. I am the person responsible in my firm for the price(s) and the amount of this Quote.

I state that:

(1) The price(s) and amount of this Quote have been arrived at independently and without consultation, communication or agreement with any other contractor, Quoter or potential Quoter, except as disclosed on the attached appendix.

(2) That neither the price(s) nor the amount of this Quote, and neither the approximate price(s) nor approximate amount of this Quote, have been disclosed to any other firm or person who is a Quoter or potential Quoter, and they will not be disclosed before Quote opening.

(3) No attempt has been made or will be made to induce any firm or person to refrain from Quoting on this contract, or to submit a Quote higher than this Quote, or to submit any intentionally high or noncompetitive Quote or other form of complementary Quote.

(4) The Quote of my firm is made in good faith and not pursuant to any agreement or discussion with, or inducement from, any firm or person to submit a complementary or noncompetitive Quote.

(5) \_\_\_\_\_, its affiliates, subsidiaries, officers,  
(Name of my Firm)

directors and employees are not currently under investigation by any governmental agency and have not in the last four years been convicted of or found liable for any act prohibited by State or Federal law in any jurisdiction, involving conspiracy or collusion with respect to Quoting on any public contract, except as described on the attached appendix.

I state that \_\_\_\_\_ understands and acknowledges that the  
(Name of my Firm)

above representations are material and important, and will be relied on by School District No. 4J in awarding the contract(s) for which this Quote is submitted. I understand and my firm understands that any misstatement in this affidavit is and shall be treated as fraudulent concealment from School District No. 4J of the true facts relating to the submission of Quotes for this contract.

\_\_\_\_\_  
(Authorized Signature)

Sworn to and subscribed before me this

\_\_\_\_\_ day of \_\_\_\_\_, 2016

\_\_\_\_\_  
(Notary Public for Oregon)

My Commission Expires: \_\_\_\_\_

END OF QUOTE FORM

**Section 00 50 00**  
**CONSTRUCTION CONTRACTOR AGREEMENT**  
**(Sample Form)**  
**LANE COUNTY SCHOOL DISTRICT 4J**  
**715 West Fourth Avenue**  
**Eugene, Oregon 97402**

This Agreement is hereby made between the Lane County School District 4J, hereinafter DISTRICT, and CONTRACTOR, according to the following terms, conditions and provisions:

1. CONTRACTOR is identified as follows:

Firm Name: \_\_\_\_\_

Contractor's Representative \_\_\_\_\_

Address: \_\_\_\_\_

City/State/ZIP: \_\_\_\_\_ Email: \_\_\_\_\_

Business Telephone: \_\_\_\_\_ FAX: \_\_\_\_\_

Social Security Number: \_\_\_\_\_ or Federal Employer ID: \_\_\_\_\_

Type of Entity:      Sole Proprietorship    Partnership    Corporation

2. SERVICES TO BE PROVIDED (Include scope of work, schedule and other provisions including supplies, materials, equipment or services, as applicable):

\_\_\_\_\_  
\_\_\_\_\_

3. DISTRICT'S REPRESENTATIVE: \_\_\_\_\_

4. FINGERPRINTING REQUIREMENTS: Do services to be provided include potential for direct, unsupervised contact with students?      Yes    No

If yes, has CONTRACTOR been fingerprinted?      Yes    No

5. DATE AND DURATION: This agreement shall be effective commencing on \_\_\_\_\_ and extending through \_\_\_\_\_, unless otherwise terminated or extended.

6. PAYMENT: The DISTRICT shall pay the CONTRACTOR the agreed sum of \$ \_\_\_\_\_  
\_\_\_\_\_ for work described herein.

Purchase Order or Account Number to be charged: \_\_\_\_\_

7. CONTRACTOR REQUIREMENTS: The CONTRACTOR agrees to perform the work or services as described in this Agreement in accordance with the Terms and Conditions of this Agreement (ATTACHMENT A) and Drawings and Specifications listed below:

\_\_\_\_\_  
\_\_\_\_\_

8. CONTRACTOR is an Independent Contractor within the meaning of ORS 670.600 and is not an employee of the DISTRICT.

9. SIGNATURES: It is so agreed this \_\_\_\_\_ day of \_\_\_\_\_, \_\_\_\_\_

\_\_\_\_\_  
CONTRACTOR

\_\_\_\_\_  
Date

\_\_\_\_\_  
DISTRICT

\_\_\_\_\_  
Date

**SECTION 00 50 01**  
**CONSTRUCTION CONTRACTOR AGREEMENT TERMS & CONDITIONS**  
**with PERFORMANCE BOND AND PAYMENT BOND, PREVAILING WAGES**  
**November 22,2016**

This Construction CONTRACTOR Agreement between the DISTRICT and the CONTRACTOR includes the following terms, conditions, and provisions:

- 1. DECLARATION OF INDEPENDENT CONTRACTOR:** CONTRACTOR declares that CONTRACTOR has complied with all federal, state, and local laws regarding business permits, registrations, certificates, and licenses that may be required to carry out the work to be performed under this agreement. The CONTRACTOR represents that the CONTRACTOR qualifies as an independent CONTRACTOR as evidenced by agreement to the conditions of this contract. The CONTRACTOR represents that all the information in the agreement is true and the DISTRICT may contact individuals and corporations to verify this information. The DISTRICT relies upon the representation of the CONTRACTOR. In the event the CONTRACTOR is determined not to be an independent CONTRACTOR for the purpose of providing these services to the DISTRICT, then the CONTRACTOR will reimburse the DISTRICT's full costs and damages associated with or in any way related to this determination.
- 2. CONTRACTORS' REGISTRATION:** The CONTRACTOR and each Subcontractor shall be registered, prior to the commencement of the Work, and maintain, for the duration of the Project, a registration with the Oregon State Construction CONTRACTORS' Board.
- 3. RESPONSIBILITY TEST:** CONTRACTOR certifies that the CONTRACTOR: a) has available the appropriate financial, material, equipment, facility and personnel resources and expertise, or the ability to obtain the resources and expertise, necessary to meet all contractual responsibilities; b) has a satisfactory record of past performance; c) has a satisfactory record of integrity, is not disqualified under ORS279C.440; and d) is qualified legally to contract with the DISTRICT.
- 4. PERMITS, FEES AND NOTICES:** The DISTRICT will pay the plan check fee, building permit fee, and systems development charges directly to the authority having jurisdiction. The CONTRACTOR shall comply with and give notices required by laws, ordinances, rules, regulations and lawful orders of public authorities bearing on performance of the work of this contract. The CONTRACTOR shall secure and pay for all other permits, fees and inspections necessary for the proper execution and completion of the Contract, which are legally required when bids are received or negotiations concluded. The CONTRACTOR shall pick up permits and call for inspections through final inspection, as required by the City Building Department.
- 5. USE OF SITE:** Check in daily with the school or facility office personnel and the building custodian to coordinate construction activities with the ongoing activities at the building.
- 6. BACKGROUND CHECK: Waived for this Work.** ~~CONTRACTOR and its employees and CONTRACTOR volunteers who will have direct, unsupervised contact with students shall be required to submit fingerprints and undergo a state and nationwide fingerprinting and criminal history records check as required by ORS 326.603 and further defined by ORS 342.143. Direct, unsupervised contact is defined as being present in the school without direct DISTRICT supervision while scheduled classes and scheduled extracurricular activities are taking place. Those CONTRACTORS determined not to be in direct contact with students need not submit for a background check.~~
  - ~~a. Begin Initial Background Check: log onto <https://www.helpcounterweb.com/welcome/apply.php?district=eugene> Complete entire form, and state: "Contractor Background Check" in Comment box.~~
  - ~~b. Review and approval of Initial Background Check is made by 4J Human Resources via e-mail correspondence. Approval will include instructions to obtain photo ID Badge and Fingerprint packet at Facilities Management, 715 W. 4<sup>th</sup> Ave. Eugene, OR. Fingerprint packet contains fingerprint card and Fingerprint Based Criminal History Verification form.~~
  - ~~c. Follow instructions on Fingerprint packet for locations for where fingerprinting services are administered, and immediately complete fingerprinting process. Fee: \$15.00~~
  - ~~d. Return fingerprinting and completed form for processing and notarization to Eugene School DISTRICT 4J Human Resources Department, 200 N. Monroe, Eugene, OR. Fee: \$59.00.~~
  - ~~e. Work may commence upon approval of Initial Background Check and issuance of ID Badge. ID Badge must be prominently displayed at all times.~~
  - ~~f. All costs associated with background check and fingerprinting are borne by the CONTRACTOR.~~
- 7. SMOKING, DRUG AND ALCOHOL POLICIES:** Smoking and the other use of tobacco products is prohibited on all school DISTRICT property pursuant to OAR 581-021-0110. DISTRICT Policy prohibits the possession, use or distribution of illicit drugs and alcohol on school premises. Anyone under the treatment of a physician who must bring prescription medications to the workplace shall carry the medicines in the original container bearing the name of the

drug, the name of the physician and the prescribed dosage. The CONTRACTOR is required to demonstrate that an employee drug testing program is in place.

**8. POTENTIALLY HAZARDOUS PRODUCTS:** The DISTRICT attempts to maintain a safe and healthy environment for students and staff. The CONTRACTOR is therefore required to follow DISTRICT guidelines controlling the use of potentially hazardous products and to use these products in a safe manner.

MSDS information is required for all potentially hazardous products. The Project Manager and a DISTRICT Safety Specialist will review these and determine what, if any, mitigation procedures will be required. CONTRACTOR is to maintain and post copies of all MSDS information at the project site and adhere to the required controls.

CONTRACTOR is to ensure that work area access by students and teachers is restricted. The DISTRICT will provide signage appropriate for this purpose. The CONTRACTOR is to construct and maintain appropriate barriers.

**9. ASBESTOS CONTAINING MATERIALS:** Prior to commencing work on-site, the CONTRACTOR shall contact the DISTRICT Asbestos Specialist, to review the Asbestos Management Plan for the site where the work will be performed. The CONTRACTOR shall not, in any way, disturb materials which are known to contain asbestos, assumed to contain asbestos, or otherwise have not been tested and confirmed to be asbestos free. The DISTRICT will investigate and test for asbestos containing materials and, if required, remove such materials as required for the Work. CONTRACTOR is required to sign an Asbestos Containing Materials Notification Statement as supplied by DISTRICT prior to commencing Work. The CONTRACTOR shall use no asbestos-containing materials in the Work and shall so certify.

**10. SAFETY REQUIREMENTS:** Safety must not be sacrificed for the sake of productivity or expedience. Safety of students, staff, and the public is critical. All CONTRACTORS who perform work on DISTRICT property, and their employees, are expected to know the DISTRICT's expectations for safe work and to adhere to those expectations. CONTRACTOR shall adhere to the regulations of Oregon OSHA for all projects within the School DISTRICT.

**11. ELECTRICAL REQUIREMENTS:**

**LOCKOUT/TAGOUT:** CONTRACTOR shall implement a Lockout/Tagout program for employees who take equipment out of service or place equipment back into service after repair. CONTRACTOR shall review the DISTRICT's Energy Control Program prior to commencing work. Rules applying to this procedure are Oregon Occupational Safety and Health Code OAR 437-002-0140, General Environmental Controls Lockout/Tagout (1919.147), or latest version.

**ARC FLASH – ELECTRICAL SAFETY:** CONTRACTOR shall comply with NFPA 70E (Electrical Safety in the Workplace), current edition. CONTRACTOR shall comply with Oregon OSHA 1910.137 (Personal Protective Equipment). The CONTRACTOR shall review with the School DISTRICT Project Manager the 'Eugene School DISTRICT Electrical Safety Program' before any work commences. The CONTRACTOR shall comply with all 'Arc Flash' and 'Electrical Safety' protocols referenced in any and all NFPA, OSHA, OROSHA, NEC, NESC, UL, IBC, IFC and ANSI documents (current editions).

**12. CONFINED SPACE REQUIREMENTS:** If work requires entering underground fuel storage tanks, utility tunnels, sewer vaults (where septic systems are located) or fireboxes on boilers, a permit and special training is required, when necessary under OAR 437-002-0140.

**13. HOLD HARMLESS AND INDEMNIFICATION:** To the fullest extent of the law, the CONTRACTOR will defend, indemnify, hold harmless and reimburse the Eugene School DISTRICT 4J (including its officers, board members, agents, and employees) from all claims, demands, suits, actions, penalties, and damage expenses, for liability of any kind including attorney's fees. To the extent that death or bodily injury to persons or damage to property arises out of the fault of the CONTRACTOR, the CONTRACTOR's indemnity obligation exists only to the extent that the death or bodily injury to persons or damage to property arises out of the fault of the CONTRACTOR, or the fault of the CONTRACTOR's agents, representatives or Subcontractors, contributed to or caused such damage, whether or not such incidents are contributed to or caused in any part by Eugene School DISTRICT 4J.

**14. INSURANCE:** The CONTRACTOR shall maintain in force for the duration of this agreement, the following:

**General Insurance:** The CONTRACTOR shall maintain in force for the duration of this agreement a Umbrella Insurance Policy with the limits not less than \$5,000,000, a Commercial General Liability, Automobile Liability (owned, non-owned and hired) Insurance policy(s) written on an occurrence basis with limits not less than \$1,000,000 per occurrence and \$2,000,000 in the aggregated naming the DISTRICT, its employees, officials and agents as an additional insured as respects to work or services performed under this agreement. This insurance will be primary to any insurance the DISTRICT may carry on its own. If the DISTRICT requires Professional Liability coverage, the terms, conditions, and limits must be approved by the DISTRICT's Risk Manager.

**Workers' Compensation:** The CONTRACTOR shall provide and maintain workers' compensation coverage for its employees, officers, agents, or partners as required by applicable workers' compensation laws.

**Equipment and Material:** The CONTRACTOR shall be responsible for any loss, damage, or destruction of its own property, equipment, and materials used in connection with the work.

**Course of Construction:** The CONTRACTOR shall maintain an all-risk policy covering the replacement cost of the Work during the course of construction. The policy shall include the interests of the DISTRICT and the Architect. The amount of insurance shall equal the completed value of the contract.

**Property Insurance:** The CONTRACTOR shall purchase from and maintain in a company or companies authorized to do business in the jurisdiction in which the Project is located, property insurance on an "all risk" policy form, including builder's risk/installation floater, whichever is appropriate, in the amount of the initial Contract Sum, plus the value of subsequent modifications and the cost of materials supplied by others, comprising the total value of the entire Project at the site on a replacement cost basis without optional deductibles. Such property insurance shall be maintained, unless otherwise provided in the Contract Documents or otherwise agreed in writing by all persons and entities who are beneficiaries of such insurance, until final payment has been made as provided in The Contract Documents or until no person or entity other than the DISTRICT has an insurable interest in the property required by this paragraph to be covered, whichever is later. The insurance shall include interests of the DISTRICT, Architect and CONTRACTOR, Subcontractors, and sub-Subcontractors in the Project. Clarification: Deletion of installation floater/all risk policy waives the requirements of the Contractor or Owner to provide installation floater/all risk policy for this project.

**Evidence of Coverage:** Evidence of the above coverages issued by a company satisfactory to the DISTRICT shall be provided to the DISTRICT by way of a certificate of insurance before any work or services commence. A 30-day notice of cancellation or material change in coverage clause shall be included. It is the CONTRACTOR's obligation to provide the 30 days' notice if not done so by the CONTRACTOR's insurance company(s). Failure to maintain the proper insurance shall be grounds for immediate termination of this Agreement.

**Subcontractors:** The CONTRACTOR shall require all Subcontractors to provide and maintain general liability, auto liability, professional liability (as applicable), and workers' compensation insurance with coverage equivalent to those required of the general CONTRACTOR in this contract. The CONTRACTOR shall require certificates of insurance from all Subcontractors as evidence of coverage.

**Exception or Waivers:** Any exception or waiver of these requirements shall be subject to review and approval from the DISTRICT's Risk Manager.

**15. PERFORMANCE BOND AND PAYMENT BOND:** The CONTRACTOR shall furnish a Performance bond and a Labor and Materials Payment bond covering faithful performance of the Contract and payment of obligations arising there under. Bonds are to be obtained through a company that is on the US Government Treasury list for approved sureties and/or approved by School DISTRICT 4J's Risk Manager. The cost of the Bond shall be included in the Contract Sum. The amount of each bond shall be equal to 100 percent of the Contract Sum. Submit on AIA Document A312, latest edition. The CONTRACTOR shall deliver the required bonds to the DISTRICT with the executed Agreement. The CONTRACTOR shall require the Attorney-in-fact who executes the required bonds on behalf of the surety to affix thereto a certified and current copy of their power of attorney.

**16. LIQUIDATED DAMAGES:** The DISTRICT will suffer financial loss if the Work is not Substantially Complete, on the date specified for work to be substantially complete. The CONTRACTOR and the CONTRACTOR's surety shall be liable for and shall pay the DISTRICT the sum hereinafter stipulated as fixed, agreed, and liquidated damages for each calendar day of delay until the date established in the Certificate of Substantial Completion.

The agreed amount of liquidated damages is \$50.00 per each calendar day. The amount of liquidated damages may be reduced in cases of partial occupancy, at the sole discretion of the DISTRICT.

**17. OWNERSHIP OF WORK PRODUCT:** All work products of the CONTRACTOR, which result from this contract, shall be the exclusive property of the DISTRICT and shall be delivered to the DISTRICT upon completion of the work or termination of this contract, except as otherwise agreed in writing.

**18. EQUIPMENT, TOOLS, MATERIALS, OR SUPPLIES:** CONTRACTOR shall supply, at CONTRACTOR's sole expense, all equipment, tools, materials and/or supplies to accomplish the services agreed upon. The CONTRACTOR shall be responsible for any loss, damage, or destruction of its own property, equipment, and materials used in conjunction with the work.

**19. REIMBURSEMENT OF EXPENSES:** The DISTRICT shall not be liable to CONTRACTOR for any expenses paid or incurred by the CONTRACTOR unless previously agreed to in writing.

**20. FRINGE BENEFITS:** Because CONTRACTOR is engaged in CONTRACTOR's own independently established business, CONTRACTOR is not eligible for, and shall not participate in, any employee pension, health, or other fringe benefit plan, of the DISTRICT.

**21. HOURS OF LABOR:** No person shall be employed for more than ten hours in any one day, or 40 hours in any one week, except in the cases of necessity, emergency, or where the public policy absolutely requires it, and in such cases the person so employed shall be paid at least time and a half of the regular pay for all time worked.

- a. For all overtime in excess of eight hours a day or 40 hours in any one week when the work week is five consecutive days, Monday through Friday; or
- b. For all overtime in excess of 10 hours a day or 40 hours in any one week when the work week is four consecutive days, Monday through Friday; and
- c. For all work performed on Saturday and on any legal holiday specified in ORS 279C.540.

The CONTRACTOR shall give notice to employees who work on a public contract in writing, either at the time of hire or before commencement of work on the contract, or by posting a notice in a location frequented by employees of the number of hours per day and days per week the employees may be required to work.

**22. PAYMENT OF LABORERS AND MATERIALMEN, CONTRIBUTIONS TO INDUSTRIAL ACCIDENT FUND, LIENS AND WITHHOLDING TAXES:** The CONTRACTOR shall: (1) Make payment promptly, as due, to all persons supplying to such CONTRACTOR labor or material for the prosecution of the Work provided for in such contract. (2) Pay all contributions or amounts due the Industrial Accident Fund from such CONTRACTOR or Subcontractor incurred in the performance of the contract. (3) Not permit any lien or claim to be filed or prosecuted against the state, county, school DISTRICT, municipality, municipal corporation or subdivision thereof, on account of any labor or material furnished. (4) Pay to the Department of Revenue all sums withheld from employees pursuant to ORS 316.167.

**23. PAYMENT FOR MEDICAL CARE AND PROVIDING WORKERS' COMPENSATION:** The CONTRACTOR shall promptly, as due, make payment to any person, co-partnership, association or corporation, furnishing medical, surgical and hospital care or other needed care and attention, incident to sickness or injury, to the employees of such CONTRACTOR, of all sums which the CONTRACTOR agrees to pay for such services and all moneys and sums which the CONTRACTOR collected or deducted from the wages of employees pursuant to any law, contract or agreement for the purpose of providing or paying for such service. All employers working under this contract are subject employers and must comply with ORS 656.017.

**24. PAYMENT OF CLAIMS BY PUBLIC OFFICERS:** If the CONTRACTOR fails, neglects or refuses to make prompt payment of any claim for labor or services furnished to the CONTRACTOR or a Subcontractor by any person in connection with the public contract as such claim becomes due, the proper officer or officers representing the DISTRICT may pay such claim to the person furnishing the labor or services and charge the amount of the payment against funds due or to become due the CONTRACTOR by reason of such contract. The payment of a claim in this manner shall not relieve the CONTRACTOR or the CONTRACTOR's surety from obligation with respect to any unpaid claims.

**25. FEDERAL, STATE, AND LOCAL PAYROLL TAXES:** Neither federal, nor state, nor local income tax nor payroll tax of any kind shall be collected, withheld or paid by the DISTRICT on behalf of the CONTRACTOR or of employees of the CONTRACTOR. CONTRACTOR shall not be treated as an employee with respect to the services performed hereunder for federal or state tax purposes.

**26. PREVAILING WAGE RATES:** When the total price of the Project is \$50,000 or more, each worker in each trade or occupation employed in the performance of this Contract either by the CONTRACTOR, Subcontractor or other person doing or contracting to do contracting for the whole or any part of the Work on the Contract shall be paid not less than the applicable prevailing rate of wage.

- a. The existing Oregon prevailing rate of wage in effect at the time the specifications are first advertised for bid solicitations is the applicable rate.
- b. The DISTRICT will pay the public works fee to Oregon Bureau of Labor and Industries.
- c. Certification of rate or wage by CONTRACTOR or Subcontractor (ORS 279C.845):

.1 The CONTRACTOR or the CONTRACTOR's surety and every Subcontractor or the Subcontractor's surety shall file certified statements with the public agency in writing, on a form prescribed by the Commissioner of the Bureau of Labor and Industries, certifying the hourly rate of wage paid each worker whom the CONTRACTOR or the Subcontractor has employed upon the public works, and further certifying that no worker employed upon the public works has been paid less than the prevailing rate of wage or less than the minimum hourly rate of wage specified in the contract. The certificate and statement shall be verified by the oath of the CONTRACTOR or the CONTRACTOR's surety or Subcontractor or the Subcontractor's surety that the CONTRACTOR or Subcontractor has read the statement and certificate and knows the contents thereof and that the same is true to the CONTRACTOR or Subcontractor's knowledge. The certified statements shall set out accurately and completely the payroll records for the prior week, including the name and address of each worker, the worker's correct classification, rate of pay, daily and weekly number of hours worked, deductions made, and actual wages paid.

.2 If the CONTRACTOR does not file certified payroll as required (at least once per month) the DISTRICT will withhold 25% of the amounts due the CONTRACTOR, in addition to any other required retainage.

.3 If a first-tier Subcontractor does not file certified payroll reports as required, the prime CONTRACTOR shall withhold 25% of amounts due the first-tier Subcontractor.

.4 Each certified statement required by subsection (1) of this section shall be delivered or mailed by the CONTRACTOR or Subcontractor to the public contracting agency. Certified statements shall be submitted to the public contracting agency once a month by the fifth business day of the following month, for each week workers are employed. Information submitted on certified statements may be used only to ensure compliance with the provisions of ORS 279C.800 to 279C.870.

.5 Each CONTRACTOR or Subcontractor shall preserve the certified statements for a period of three years from the date of completion of the contract.

.6 Certified statements received by a public agency are public records subject to the provisions of ORS 192.410 to 192.505. As such, they must be made available upon request.

- d. For every quote \$100,000 or greater, all Contractors and Subcontractors shall have a public works bond, in the amount of \$30,000, filed with the Construction Contractors' Board (CCB), before starting work on the project, unless exempt.
- e. Contractor shall include in every subcontract a provision requiring their Subcontractors to have a public works bond filed with the CCB before starting work on the project, unless exempt. Contractors shall verify that all of their subcontractors have filed a public works bond with the CCB.

**27. SUBCONTRACTORS:** The CONTRACTOR shall include in any subcontract for property or services entered into by the CONTRACTOR and Subcontractor, including a material supplier, for the purpose of performing a construction contract:

- a. A payment clause that obligates the CONTRACTOR to pay the Subcontractor for satisfactory performance under its subcontract within 10 days out of such amounts as are paid to the CONTRACTOR by the DISTRICT under such contract; and
- b. An interest penalty clause that obligates the CONTRACTOR to pay to the Subcontractor an interest penalty on amounts due in the case of each payment not made in accordance with the payment clause included in the subcontract pursuant to the above paragraph for the period beginning on the day after the required Payment date and ending on the date on which payment of the amount due is made; computed at the rate specified in ORS 279C.580.

**28. PROJECT CLOSEOUT:** When the Work is determined to be complete:

- a. Return all keys to DISTRICT Representative.
- b. Where warranties are required, submit original warranty certificates and indicate dates of coverage.
- c. Submit any operation and maintenance information required by technical specifications.
- d. Submit any as-built drawings or other as-built documentation required by technical specifications.
- e. Submit AIA Document G707 Consent of Surety Company for final payment.
- f. Submit Affidavit of Prevailing Wages Paid (Sample will be furnished at completion of work).
- g. Submit Asbestos-Containing Materials Statement (Sample will be furnished at completion of work.)
- h. Certificate of Insurance evidencing continuation of liability coverage including coverage for completed operations until the expiration of the specified warranty periods.
- i. Where a building permit is required, submit documentation of Building Department inspection and acceptance.
- j. Final payment will be authorized after all project closeout tasks have been completed and the work is determined to be acceptable by the DISTRICT Project Manager.

**29. NON-DISCRIMINATION:** The CONTRACTOR, by signing this agreement certifies that the CONTRACTOR has not discriminated against minorities, women or emerging small business enterprises in obtaining any required subcontracts.

The CONTRACTOR agrees not to discriminate against any client, employee or applicant for employment or for services, because of race, color, religion, sex, national origin, physical or mental handicap, sexual orientation or age unless based upon bona fide occupational qualifications, and that they are otherwise in compliance with all federal, state and local laws prohibiting discrimination, with regard to, but not limited to, the following: Employment upgrading, demotion or transfer; Recruitment or recruitment advertising; Layoffs or termination; Rates of pay or other forms of compensation; Selection for training; Rendition of services. It is further understood that any vendor who is in violation of this clause shall be barred forthwith from receiving awards of any purchase order from the School



DISTRICT, unless a satisfactory showing is made that discriminatory practices have terminated and that a recurrence of such acts is unlikely.

**30. FOREIGN CONTRACTORS:** In the event this Contract is awarded to a CONTRACTOR not domiciled in or registered to do business in the State of Oregon and the contract price exceeds \$10,000.00, the CONTRACTOR shall promptly report to the Department of Revenue the total price, terms of payment, length of contract, and such other information as the Department of Revenue may require before final payment can be received on the public contract. The DISTRICT will satisfy itself that the requirement of this subsection has been complied with before it issues a Final Payment.

**31. TERMINATION WITH CAUSE:** With reasonable cause, either party may terminate this agreement effective immediately upon the giving of written notice of termination for cause. Reasonable cause shall include:

- a. Material violation of this agreement.
- b. Any act exposing the other party to liability to others for personal injury or property damage.

**32. REMEDIES:** In the event of a termination of this contract by the DISTRICT, because of a breach by CONTRACTOR, the DISTRICT may complete the work either by itself or by contract with other persons, or any combination thereof. CONTRACTOR shall be liable to the DISTRICT for any costs or losses incurred by the DISTRICT arising out of or related to the breach, including costs incurred in selecting other CONTRACTORS, time delay losses, attorney fees, and the like, less the remaining unpaid balance of the consideration until DISTRICT's costs and losses have been determined, at which time the DISTRICT may offset any such amount due CONTRACTOR against costs and losses incurred by DISTRICT.

**33. TERMINATION OR SUSPENSION OF CONTRACT FOR CONVENIENCE:** Any contract may be terminated, or temporarily suspended, by the DISTRICT in the event that the project is permanently abandoned, or deferred, as determined in the sole discretion of the DISTRICT. The DISTRICT may terminate, or suspend, any contract in whole or in part whenever the DISTRICT determines, in its sole discretion, that such action is in the DISTRICT's best interest. Whenever any contract is terminated, or suspended in accordance with this paragraph, the CONTRACTOR shall be entitled to payment for actual work performed at contract prices for completed items of work. An equitable adjustment in any contract price for partially completed items of work will be made, but such adjustment shall not include provisions for loss of anticipated profit on deleted or uncompleted work. For suspended work, the CONTRACTOR will be entitled to five percent (5%) per year of the value of the work suspended, only if ultimately completed, and reasonable re-mobilization costs, if applicable. Termination or suspension of any contract by the DISTRICT at any time during the term for convenience, shall not constitute a breach of any contract by the DISTRICT.

**34. ASSIGNMENT:** CONTRACTOR shall not assign this contract, in whole or in part, or any right or obligation hereunder, without the DISTRICT's prior written approval.

**35. NO AUTHORITY TO BIND CLIENT:** CONTRACTOR has no authority to bind or obligate the DISTRICT or to enter into contracts or agreements on behalf of the DISTRICT. This agreement does not create a partnership, joint venture or agency between the parties.

**36. NON-WAIVER:** The failure of either party to exercise any of its rights under this agreement for a breach thereof, shall not be deemed to be a waiver of such rights or a waiver of any subsequent breach.

**37. NOTICES:** Any notice given in connection with this agreement shall be given in writing and shall be delivered either by hand to the signing party or by regular and certified mail to the party at the party's address stated herein.

**38. CHOICE OF LAW:** Any dispute under this agreement or related to this agreement shall be decided in accordance with the laws of the State of Oregon.

**39. ATTORNEY'S FEES:** In the event of any action to enforce or interpret this contract, the prevailing party shall be entitled to recover from the losing party reasonable attorney fees incurred in the proceeding, as set by the court, at trial, upon appeal, or upon review.

**40. ENTIRE AGREEMENT:** This is the entire agreement of the parties, and supersedes any prior agreement.

**41. SEVERABILITY:** If any part of this agreement shall be held unenforceable, the rest of this agreement will nevertheless remain in full force and effect.

**42. AMENDMENTS:** This agreement may be supplemented, amended, or revised only in writing by agreement of the parties.

**43. DEBARMENT CERTIFICATION:** The CONTRACTOR/Vendor certifies that the CONTRACTOR is not presently debarred, suspended, proposed for debarment, declared ineligible, or voluntarily excluded from participating in this Contract by any Federal department or agency. If requested by the Eugene 4J School DISTRICT, the CONTRACTOR shall complete a Certification Regarding Debarment, Suspension, Ineligibility, and Voluntary Exclusion form. Any such form completed by the CONTRACTOR for this Contract shall be incorporated into this Contract by reference.

- 44. CONTRACTOR'S MARK UP FOR CHANGE ORDER WORK:** The allowance for the combined overhead and profit included in the total net cost to the DISTRICT shall be based as follows:
- a. The maximum allowable hourly wage rate for Changes to the Work shall be the appropriate Base Wage Rate plus Fringe Rate as listed for each occupation in the Prevailing Wage Rate for Public Works Contracts in Oregon manual issued by the Oregon Bureau of Labor and Industries (the current issue in effect on the date the quote is first advertised and/or a quote is first requested); multiplied by 1.25. An amount for Overhead and Profit may be added in accordance with section b through h below.
  - b. For the CONTRACTOR, for work performed by the CONTRACTOR, 15 percent of the amount due the CONTRACTOR.
  - c. For the CONTRACTOR, for Work performed by the CONTRACTOR's Subcontractor, 10 percent of the amount due the Subcontractor.
  - d. For each Subcontractor or Sub-Subcontractor involved, for Work performed by that Subcontractor's or Sub-Subcontractor's own forces, 10 percent of the cost.
  - e. Total overhead and profit shall not exceed 25% of the base cost of the work (base cost being defined as the cost of the work without markups.)
  - f. Itemize costs to include breakdown for materials and labor, overhead and profit.
  - g. A change to the work providing a net CREDIT to the DISTRICT shall include a credit for overhead and profit based on the following schedule:
    - 1. For the CONTRACTOR, 5 percent of the Cost to be credited.
    - 2. For each Subcontractor, 5 percent of the Cost to be credited.
    - 3. For each Sub-Subcontractor, 5 percent of the Cost to be credited.
  - h. In order to facilitate checking of quotations for extras or credits, all proposals, except those so minor that their propriety can be seen by inspection, shall be accompanied by a complete itemization of costs including Subcontractor and CONTRACTOR overhead and profit as applicable.
- 45. APPLICATION FOR PAYMENT:** Submit payment request on invoice customarily used by CONTRACTOR. Identify 5% retainage to be carried until the project is determined to be complete.

END OF TERMS AND CONDITION

**PREVAILING WAGE RATES  
SECTION 00 73 43**

PART 1 GENERAL

The "Prevailing Wage Rates" dated June 1, 2016, including any subsequent corrections or amendments issued by the Oregon Bureau of Labor and Industries, are included as a portion of the Contract Documents by reference. Copies are available for review at the office of Facilities Management, School District 4J, and can be viewed on line at [www.boli.state.or.us](http://www.boli.state.or.us). Click on Prevailing Wages, then PWR Rate Publications, and then Prevailing Wage Rates for Public Works Contracts in Oregon (subject only to state law).

END OF SECTION 00 73 43

**SUMMARY OF WORK**  
**SECTION 01 11 00**

PART 1 - GENERAL

1.1 RELATED DOCUMENTS

- A. Drawings and general provisions of the Contract, including General and Supplementary Conditions and other Division 1 Specification Sections, apply to this Section.

1.2 WORK COVERED BY CONTRACT DOCUMENTS

- A. Project Identification: Project consists of installing owner provided scoreboard & steel columns in concrete piers as well as extending existing conduit to the scoreboard. Alternate pricing will be requested to pull wire & make final electrical connections.

- 1. Project Location: South Eugene HS, 400 East 19<sup>th</sup> Ave. Eugene, OR 97401
- 2. Owner: Eugene School District 4J, 715 West Fourth Avenue, Eugene, OR 97402.

- B. Architect Identification: The Contract Documents, dated Nov. 22, 2016, were prepared for Project by: Michael Heffernan, AIA, 715 W. 4<sup>th</sup> Ave., Eugene, OR 97402

- C. Owner's representative: Michael Heffernan, AIA

1.3 CONTRACT

- A. Project will be constructed under a general construction contract.

- 1. SEHS Softball Scoreboard Installation 2016

1.4 WORK SEQUENCE

- A. Do not commence Work until after execution of Agreement and receipt of Notice-to-Proceed from Owner.
- B. Perform work in order to achieve Substantial Completion by February 15, 2017.
- C. Achieve Final Completion within seven (7) days following the date of Substantial Completion.

1.5 USE OF PREMISES

- A. Work Area Access: Buildings will be occupied during work. Access to the work area will be available on a week-day basis from approximately 7:00 am to 4:00 pm. Coordinate all other work hour schedules with Owner so as not to interfere with Owner's use of the building.
- B. Limit use of the premises to construction activities in areas indicated; allow for Owner occupancy and use by the public, subject to approval by a District Safety Specialist.
- C. Site Access: Maintain drives and building entrances and exits clear and protected at all times to Owner's, employees, and public access and for use by emergency personnel. Do not use

## SUMMARY OF WORK – SECTION 01 11 00

these areas for parking or storage. Schedule deliveries to minimize space and time requirements for storage of materials at site.

- D. Parking: Contractor may use existing parking areas.
- E. Contractor Staging Areas: Limit staging to areas adjacent to work.
- F. Construction Operations: Limited to areas adjacent to work.

### 1.6 WORK UNDER SEPERATE CONTRACTS

- A. Separate Contract: Owner may perform or award a separate contract for performance of certain construction operations at Project site. Those operations may be conducted simultaneously with work under this Contract.
- B. Cooperate fully with owner or separate contractors so work on those contracts may be carried out smoothly, without interfering with or delaying work under this Contract.

### 1.7 FUTURE WORK

- 1. None Listed.

### 1.8 PRODUCTS ORDERED IN ADVANCE

- 1. None Listed.

### 1.9 OWNER-FURNISHED PRODUCTS

- A. Owner will furnish Scoreboard & upright steel I-beams. The Work includes providing concrete piers to support Owner's equipment as well as extending conduit, pulling wire & providing electrical connections.
  - 1. Owner will arrange for and deliver Product Data of scoreboard, to Contractor.
  - 2. Contractor shall inspect owner furnished items at start of project to ensure nothing is missing & all is in working order.
  - 3. If Owner-furnished items are found to be damaged, defective, or missing, Contractor shall notify Architect immediately.
  - 4. Contractor shall review Shop Drawings, Product Data, and Samples and return them to Architect noting discrepancies or anticipated problems in use of product.
  - 5. Contractor is responsible for receiving, unloading, and handling Owner-furnished items at Project site.
  - 6. Contractor is responsible for protecting Owner-furnished items from damage during storage and handling, including damage from exposure to the elements.
  - 7. If Owner-furnished items are damaged as a result of Contractor's operations, Contractor shall repair or replace them.

### 1.10 MISCELLANEOUS PROVISIONS

- A. BACKGROUND CHECK - Waived for this work.
  - 1. ~~Contractor and its employees and Contractor volunteers who will have direct, unsupervised contact with students shall be required to submit fingerprints and undergo a~~

## SUMMARY OF WORK – SECTION 01 11 00

~~state and nationwide fingerprinting and criminal history records check as required by ORS 326.603 and further defined by ORS 342.143. Direct, unsupervised contact is defined as being present in the school without direct District supervision while scheduled classes and scheduled extracurricular activities are taking place. Those Contractors determined not to be in direct contact with students need not submit for a background check.~~

- a. ~~Begin Initial Background Check: log onto <https://www.helpcounterweb.com/welcome/apply.php?district=eugene> Complete entire form, and state: "Contractor Background Check" in Comment box.~~
- b. ~~Review and approval of Initial Background Check is made by 4J Human Resources via e-mail correspondence. Approval will include instructions to obtain photo ID Badge and Fingerprint packet at Facilities Management, 715 W. 4<sup>th</sup> Ave. Eugene, OR. Fingerprint packet contains fingerprint card and Fingerprint Based Criminal History Verification form.~~
- c. ~~Follow instructions on Fingerprint packet for locations for where fingerprinting services are administered, and immediately complete fingerprinting process. Fee: \$15.00~~
- d. ~~Return fingerprinting and completed form for processing and notarization to Eugene School District 4J Human Resources Department, 200 N. Monroe, Eugene, OR. Fee: \$59.00~~
- e. ~~Work may commence upon approval of Initial Background Check and issuance of ID Badge. ID Badge must be prominently displayed at all times.~~
- f. ~~All costs associated with background check and fingerprinting are borne by the Contractor.~~

### B. DRUG AND ALCOHOL POLICY

1. The possession, use, or distribution of illicit drugs and alcohol on school premises is prohibited. Prescription medications brought to the project site shall be in the original container bearing the name of the drug, the name of the physician and the prescribed dosage.

### C. USE OF TOBACCO PRODUCTS

1. Smoking and the other use of tobacco products is prohibited on all school district property pursuant to OAR 581-021-0110.

### D. SAFETY REQUIREMENTS

1. Safety must not be sacrificed for the sake of productivity or expedience. Safety of students, staff, and the public is critical. Take all reasonable precautions to prevent endangerment or injury. Advise and coordinate operations with the school office.
2. All contractors who perform work on District property, and their employees, are expected to know the District's expectations for safe work and to adhere to those expectations.
3. Contractors are to adhere to the regulations of Oregon OSHA for all projects within the School District.

### E. GENERAL SAFE WORK PRACTICES

1. Students, public and school staff shall not be put at risk by the activities of contractors or their employees.
2. Safe vehicle operation rules are to be followed at all times. These include positioning vehicles to minimize the necessity of backing and providing a "spotter", someone who will make sure that people do not run into the path of a vehicle when driving on a playground or field that is occupied by students.

## SUMMARY OF WORK – SECTION 01 11 00

3. Tools shall never be left out when an unsecured work area is vacated.
  4. Ladders and scaffolding will be taken down when an unsecured work area is vacated.
  5. Open holes and other tripping hazards shall be fenced or barricaded when an unsecured work area is vacated.
  6. Operations resulting in vapors, emissions or flying objects shall be conducted in such a way as to prevent exposure to any unprotected parties or property.
  7. "Secured Work Area" is defined as an area having a perimeter cyclone fence at least 6 feet in height, with gates which close and lock so that no casual entrance is possible by unauthorized adults or children.
  8. Contractor to follow all OR-OSHA rules for Confined Spaces, where applicable.
- F. COMMUNICATIONS REGARDING UNSAFE PRACTICES
1. Upon perceiving a problem, the District will immediately communicate the concern to the Contractor or Contractor's representative on the work site.
  2. If agreement on correction of unsafe conditions cannot be reached, the concerns of the District shall prevail and safety concerns shall be addressed in accordance with the District requirements.
- G. ELECTRICAL PANELS - LOCKOUT/TAGOUT
1. Contractor shall implement a Lockout/Tag-out program for his employees who take equipment out of service or place equipment back into service. Contractor shall review the District's Energy Control Program prior to commencing work. Rules applying to this procedure are Oregon Occupational Safety and Health Code OAR 437, Division 2, Subdivision J, General Environmental Controls Lockout/Tag-out (1919.147), or latest edition.
- H. POTENTIALLY HAZARDOUS PRODUCTS
1. The District attempts to maintain a safe and healthy environment for students and staff. The Contractor is therefore required to follow District guidelines controlling the use of potentially hazardous products and to use these products in a safe manner. Guidelines include the use of materials (adhesives, coatings, carpeting, etc.) which are known to emit little or no airborne pollutants.
  2. MSDS information is required for all potentially hazardous products. The Project Manager and a District Safety Specialist will review these and determine what, if any, mitigation procedures will be required.
  3. Contractor is to maintain and post copies of all MSDS information at the project site and adhere to the required controls.
  4. Contractor is to ensure that work area by students and teachers is restricted. The District will provide signage appropriate for this purpose. The Contractor is to construct and maintain appropriate barriers. This shall include provision of physical separation barriers between "construction" and "occupied" spaces.
- I. ASBESTOS CONTAINING MATERIALS WARNING
1. Asbestos containing materials are known to exist in areas of the Work. The Contractor shall not, in any way, disturb materials which are known to contain asbestos, assumed to contain asbestos, or otherwise have not been tested and confirmed to be asbestos free.
  2. Where access to concealed spaces is required, or it is necessary to disturb building materials such as for drilling of holes, cutting, etc., notify the Owner so that proper investigation and/or removal procedures are followed.
  3. Prior to commencing Work, the Contractor shall meet with the District Safety Specialist and review the Owner's Asbestos Management Plan for the locations of asbestos-

## SUMMARY OF WORK – SECTION 01 11 00

containing materials and/or materials assumed to contain asbestos. After reviewing the Owner's Asbestos Management Plan, the Contractor is required to sign Form 01 10 00A, Asbestos-containing Materials Notification Statement, provided at the end of this Section.

4. Contractor must not install any asbestos-containing materials when performing the Work of this project. At the completion of the Work, Contractor will be required to furnish a statement stating that no asbestos-containing materials were installed during the course of the Work. Refer to Sample Form 01 10 00B at the end of this Section

PART 2 - PRODUCTS (Not Used)

PART 3 - EXECUTION (Not Used)

PART 4 - SCHEDULE OF PRODUCTS ORDERED IN ADVANCE

PART 5 - ASBESTOS FORMS



Form 01 11 00A

**ASBESTOS-CONTAINING MATERIALS NOTIFICATION STATEMENT  
FOR CONTRACTORS**

This form must be completed and signed by the Contractor prior to beginning work in any Eugene School District 4J building.

The presence of known and assumed asbestos containing materials is documented in the AHERA Management Plan for each building. Copies of the AHERA Management Plan are available in the main office of each building and in the Facilities Management Office at 715 West Fourth Avenue, Eugene, Oregon. The District Asbestos Specialist must be informed of the Contractor’s activities in each building prior to the start of work so that the Contractor can be informed on how to use the AHERA Management Plan and to determine if any asbestos-containing materials are likely to be impacted by the work of the Contractor.

The Contractor is responsible for notifying all employees and subcontractors of the presence of asbestos in the building. The Contractor shall not disturb known or assumed asbestos-containing materials. If the Contractor discovers suspected asbestos-containing materials that have not been identified, the Contractor must stop any work impacting the suspected materials and notify the District Asbestos Specialist so that the material can be sampled. Any asbestos-containing materials that must be removed to allow the Contractor to complete the Contractor’s work will be removed by the District under separate contract. If the Contractor disturbs asbestos-containing materials, the Contractor will be responsible for the cost of the cleanup and decontamination..

I \_\_\_\_\_, Representing \_\_\_\_\_,  
(Print Name of Representative) (Business Name)

have been notified of the location of the AHERA Management Plan and agree to avoid impacting all known or assumed asbestos-containing materials in the performance of the Work.

\_\_\_\_\_  
Signature of Representative

\_\_\_\_\_  
Date

\_\_\_\_\_  
Work Site

\_\_\_\_\_  
CIP #

**Form 01 11 00B**

The Environmental Protection Agency (AHERA) rules require the School District obtain a signed statement from the Site Superintendent that, to the best of his/her knowledge, no asbestos-containing building materials were installed during the Work. Therefore, the following statement must be submitted on the Contractors letterhead prior to Project Closeout.

**SAMPLE FORM**

(To be submitted on the Contractor's letterhead)

**ASBESTOS-CONTAINING MATERIALS STATEMENT**

EUGENE SCHOOL DISTRICT 4J

---

(Name of Project)

We the undersigned, (Name of Company), hereby warrant that to the best of our knowledge all materials furnished for the above referenced project contain 0% asbestos.

---

(Name of Construction Company)

---

(Signature and Date)

---

Printed Name

---

Job Title

END OF SECTION 01 11 00

## QUALITY REQUIREMENTS

### SECTION 01 40 00

#### PART 1 - GENERAL

##### 1.1 RELATED DOCUMENTS

- A. Drawings and general provisions of the Contract, including General and Supplementary Conditions and other Division 1 Specification Sections, apply to this Section.

##### 1.2 SUMMARY

- A. This Section includes administrative and procedural requirements for quality assurance and quality control.
- B. Testing and inspecting services are required to verify compliance with requirements specified or indicated. These services do not relieve Contractor of responsibility for compliance with the Contract Document requirements.
  - 1. Specific quality-assurance and -control requirements for individual construction activities are specified in the Sections that specify those activities. Requirements in those Sections may also cover production of standard products.
  - 2. Specified tests, inspections, and related actions do not limit Contractor's other quality-assurance and -control procedures that facilitate compliance with the Contract Document requirements.
  - 3. Requirements for Contractor to provide quality-assurance and -control services required by Architect, Owner, or authorities having jurisdiction are not limited by provisions of this Section.
- C. Related Sections include the following:
  - 1. Divisions 2 through 49 Sections for specific test and inspection requirements.

##### 1.3 CONFLICTING REQUIREMENTS

- A. General: If compliance with two or more standards is specified and the standards establish different or conflicting requirements for minimum quantities or quality levels, comply with the most stringent requirement. Refer uncertainties and requirements that are different, but apparently equal, to Architect for a decision before proceeding.
- B. Minimum Quantity or Quality Levels: The quantity or quality level shown or specified shall be the minimum provided or performed. The actual installation may comply exactly with the minimum quantity or quality specified, or it may exceed the minimum within reasonable limits. To comply with these requirements, indicated numeric values are minimum or maximum, as appropriate, for the context of requirements. Refer uncertainties to Architect for a decision before proceeding.

1.4 SUBMITTALS

- A. Qualification Data: For testing agencies specified in "Quality Assurance" Article to demonstrate their capabilities and experience. Include proof of qualifications in the form of a recent report on the inspection of the testing agency by a recognized authority.
- B. Reports: Prepare and submit certified written reports that include the following:
  - 1. Date of issue.
  - 2. Project title and number.
  - 3. Name, address, and telephone number of testing agency.
  - 4. Dates and locations of samples and tests or inspections.
  - 5. Names of individuals making tests and inspections.
  - 6. Description of the Work and test and inspection method.
  - 7. Identification of product and Specification Section.
  - 8. Complete test or inspection data.
  - 9. Test and inspection results and an interpretation of test results.
  - 10. Record of temperature and weather conditions at time of sample taking and testing and inspecting.
  - 11. Comments or professional opinion on whether tested or inspected Work complies with the Contract Document requirements.
  - 12. Name and signature of laboratory inspector.
  - 13. Recommendations on retesting and reinspecting.
- C. Permits, Licenses, and Certificates: For Owner's records, submit copies of permits, licenses, certifications, inspection reports, releases, jurisdictional settlements, notices, receipts for fee payments, judgments, correspondence, records, and similar documents, established for compliance with standards and regulations bearing on performance of the Work.

1.5 QUALITY CONTROL

- A. Owner Responsibilities: Where quality-control services are indicated as Owner's responsibility, Owner will engage a qualified testing agency to perform these services.
  - 1. Owner will furnish Contractor with names, addresses, and telephone numbers of testing agencies engaged and a description of types of testing and inspecting they are engaged to perform.
  - 2. Payment for these services will be made by Owner.
  - 3. Costs for retesting and reinspecting construction that replaces or is necessitated by work that failed to comply with the Contract Documents will be charged to Contractor, and the Contract Sum will be adjusted by Change Order.
- B. Tests and inspections not explicitly assigned to Owner are Contractor's responsibility. Unless otherwise indicated, provide quality-control services specified and those required by authorities having jurisdiction. Perform quality-control services required of Contractor by authorities having jurisdiction, whether specified or not.
  - 1. Where services are indicated as Contractor's responsibility, engage a qualified testing agency to perform these quality-control services.
  - 2. Notify testing agencies at least 24 hours in advance of time when Work that requires testing or inspecting will be performed.

## QUALITY REQUIREMENTS – SECTION 01 40 00

3. Where quality-control services are indicated as Contractor's responsibility, submit a certified written report, in duplicate, of each quality-control service.
  4. Testing and inspecting requested by Contractor and not required by the Contract Documents are Contractor's responsibility.
  5. Submit additional copies of each written report directly to authorities having jurisdiction, when they so direct.
- C. **Manufacturer's Field Services:** Where indicated, engage a factory-authorized service representative to inspect field-assembled components and equipment installation, including service connections. Report results in writing as specified in Division 1 Section 01 33 00 "Submittal Procedures."
- D. **Retesting/Reinspecting:** Regardless of whether original tests or inspections were Contractor's responsibility, provide quality-control services, including retesting and reinspecting, for construction that replaced Work that failed to comply with the Contract Documents.
- E. **Testing Agency Responsibilities:** Cooperate with Architect and Contractor in performance of duties. Provide qualified personnel to perform required tests and inspections.
1. Notify Architect and Contractor promptly of irregularities or deficiencies observed in the Work during performance of its services.
  2. Determine the location from which test samples will be taken and in which in-situ tests are conducted.
  3. Conduct and interpret tests and inspections and state in each report whether tested and inspected work complies with or deviates from requirements.
  4. Submit a certified written report, in duplicate, of each test, inspection, and similar quality-control service through Contractor.
  5. Do not release, revoke, alter, or increase the Contract Document requirements or approve or accept any portion of the Work.
  6. Do not perform any duties of Contractor.
- F. **Associated Services:** Cooperate with agencies performing required tests, inspections, and similar quality-control services, and provide reasonable auxiliary services as requested. Notify agency sufficiently in advance of operations to permit assignment of personnel. Provide the following:
1. Access to the Work.
  2. Incidental labor and facilities necessary to facilitate tests and inspections.
  3. Adequate quantities of representative samples of materials that require testing and inspecting. Assist agency in obtaining samples.
  4. Facilities for storage and field curing of test samples.
  5. Delivery of samples to testing agencies.
  6. Preliminary design mix proposed for use for material mixes that require control by testing agency.
  7. Security and protection for samples and for testing and inspecting equipment at Project site.
- G. **Coordination:** Coordinate sequence of activities to accommodate required quality-assurance and control services with a minimum of delay and to avoid necessity of removing and replacing construction to accommodate testing and inspecting.

## QUALITY REQUIREMENTS – SECTION 01 40 00

1. Schedule times for tests, inspections, obtaining samples, and similar activities.

### 1.6 SPECIAL TESTS AND INSPECTIONS

- A. Special Tests and Inspections: Owner will engage a qualified testing agency to conduct special tests and inspections required by authorities having jurisdiction as the responsibility of the Owner, described as follows:

<List Special Inspections Here>

### PART 2 - PRODUCTS (Not Used)

### PART 3 - EXECUTION

#### 3.1 TEST AND INSPECTION LOG

- A. Prepare a record of tests and inspections. Include the following:
  1. Date test or inspection was conducted.
  2. Description of the Work tested or inspected.
  3. Date test or inspection results were transmitted to Architect.
  4. Identification of testing agency or special inspector conducting test or inspection.
- B. Maintain log at Project site. Post changes and modifications as they occur. Provide access to test and inspection log for Architect's reference during normal working hours.

#### 3.2 REPAIR AND PROTECTION

- A. General: On completion of testing, inspecting, sample taking, and similar services, repair damaged construction and restore substrates and finishes.
  1. Provide materials and comply with installation requirements specified in other Specification Sections. Restore patched areas and extend restoration into adjoining areas with durable seams that are as invisible as possible.
- B. Protect construction exposed by or for quality-control service activities.
- C. Repair and protection are Contractor's responsibility, regardless of the assignment of responsibility for quality-control services.

END OF SECTION 01 40 00

**PRODUCT REQUIREMENTS**  
**SECTION 01 60 00**

PART 1 - GENERAL

1.1 RELATED DOCUMENTS

- A. Drawings and general provisions of the Contract, including General and Supplementary Conditions and other Division 1 Specification Sections, apply to this Section.

1.2 SUMMARY

- A. This Section includes administrative and procedural requirements for selection of products for use in Project; product delivery, storage, and handling; manufacturers' standard warranties on products; special warranties; product substitutions; and comparable products.
- B. Related Sections include the following:
  - 1. Division 1 Section 01 77 00 "Closeout Submittals" for submitting warranties for Contract closeout.
  - 2. Divisions 2 through 49 Sections for specific requirements for warranties on products and installations specified to be warranted.

1.3 DEFINITIONS

- A. Products: Items purchased for incorporating into the Work, whether purchased for Project or taken from previously purchased stock. The term "product" includes the terms "material," "equipment," "system," and terms of similar intent.
- B. Substitutions: Changes in products, materials, equipment, and methods of construction from those required by the Contract Documents and proposed by Contractor.
- C. Basis-of-Design Product Specification: Where a specific manufacturer's product is named and accompanied by the words "basis of design," including make or model number or other designation, to establish the significant qualities related to type, function, dimension, in-service performance, physical properties, appearance, and other characteristics for purposes of evaluating comparable products of other named manufacturers.

1.4 SUBMITTALS

- A. Substitution Requests: Instructions to Bidders specify time restrictions for submitting requests for Substitutions during the bidding period, in compliance with this Section.
- B. After execution of Agreement, the Owner may, at the Owner's option, consider formal requests from the Contractor for substitution of products for those specified. One or more of the following conditions must be documented:
  - 1. Compliance with final interpretation of code requirements or insurance regulations which require that the use of a substituted Product.
  - 2. Unavailability of a specified Product through no fault of the Contractor.
  - 3. Inability of specified Product to perform properly or fit in designated place.

## PRODUCT REQUIREMENTS – SECTION 01 60 00

4. Manufacturer's or Fabricator's refusal or inability to certify or guarantee performance of a specified Product in the application intended.
- C. A Substitution Request constitutes a representation that the Bidder/Contractor:
1. Has investigated the proposed Product and determined that it meets or exceeds the quality level of the specified Product.
  2. Will provide the same warranty for the Substituted Product as for the specified Product.
  3. Will coordinate installation and make changes to the Work which may be required for the Work to be completed with no additional cost to the Owner.
  4. Waives claims for additional costs or time extension which may subsequently become apparent.
  5. Will reimburse the Owner for review or redesign services associated with re-approval by authorities.
- D. Substitutions will not be considered when they are indicated or implied on Shop Drawings or Product Data Submittals, without separate request on the form provided, or when acceptance will require revision to the Contract Documents.
- E. Submit three copies of each request for consideration. Limit each request to one proposed Substitution. Identify product or fabrication or installation method to be replaced. Include Specification Section number and title and Drawing numbers and titles.
1. Substitution Request Form: Use form provided at end of Section.
  2. Documentation: Show compliance with requirements for substitutions and the following, as applicable:
    - a. Statement indicating why specified material or product cannot be provided.
    - b. Coordination information, including a list of changes or modifications needed to other parts of the Work and to construction performed by Owner and separate contractors, that will be necessary to accommodate proposed substitution.
    - c. Detailed comparison of significant qualities of proposed substitution with those of the Work specified. Significant qualities may include attributes such as performance, weight, size, durability, visual effect, and specific features and requirements indicated.
    - d. Product Data, including drawings and descriptions of products and fabrication and installation procedures.
    - e. Provide MSDS information to confirm that the product is no more harmful than the products specified.
    - f. Samples, where applicable or requested.
    - g. List of similar installations for completed projects with project names and addresses and names and addresses of architects and owners.
    - h. Material test reports from a qualified testing agency indicating and interpreting test results for compliance with requirements indicated.
    - i. Research/evaluation reports evidencing compliance with building code in effect for Project, from a model code organization acceptable to authorities having jurisdiction.
    - j. Detailed comparison of Contractor's Construction Schedule using proposed substitution with products specified for the Work, including effect on the overall Contract Time. If specified product or method of construction cannot be provided within the Contract Time, include letter from manufacturer, on manufacturer's letterhead, stating lack of availability or delays in delivery.



## PRODUCT REQUIREMENTS – SECTION 01 60 00

- k. Cost information, including a proposal of change, if any, in the Contract Sum.
  - l. Contractor's certification that proposed substitution complies with requirements in the Contract Documents and is appropriate for applications indicated.
  - m. Contractor's waiver of rights to additional payment or time that may subsequently become necessary because of failure of proposed substitution to produce indicated results.
3. Architect's Action: If necessary, Architect will request additional information or documentation for evaluation within 7 days of receipt of a request for substitution. Architect will notify Contractor of acceptance or rejection of proposed substitution within 15 days of receipt of request, or 7 days of receipt of additional information or documentation, whichever is later.
- a. Form of Acceptance: Change Order.
  - b. Use product specified if Architect cannot make a decision on use of a proposed substitution within time allocated.

### 1.5 QUALITY ASSURANCE

- A. Compatibility of Options: If Contractor is given option of selecting between two or more products for use on Project, product selected shall be compatible with products previously selected, even if previously selected products were also options.

### 1.6 PRODUCT DELIVERY, STORAGE, AND HANDLING

- A. Deliver, store, and handle products using means and methods that will prevent damage, deterioration, and loss, including theft. Comply with manufacturer's written instructions.
- B. Delivery and Handling:
  - 1. Schedule delivery to minimize long-term storage at Project site and to prevent overcrowding of construction spaces.
  - 2. Coordinate delivery with installation time to ensure minimum holding time for items that are flammable, hazardous, easily damaged, or sensitive to deterioration, theft, and other losses.
  - 3. Deliver products to Project site in an undamaged condition in manufacturer's original sealed container or other packaging system, complete with labels and instructions for handling, storing, unpacking, protecting, and installing.
  - 4. Inspect products on delivery to ensure compliance with the Contract Documents and to ensure that products are undamaged and properly protected.
- C. Storage:
  - 1. Store products to allow for inspection and measurement of quantity or counting of units.
  - 2. Store materials in a manner that will not endanger Project structure.
  - 3. Store products that are subject to damage by the elements, under cover in a weathertight enclosure above ground, with ventilation adequate to prevent condensation.
  - 4. Store cementitious products and materials on elevated platforms.
  - 5. Store foam plastic from exposure to sunlight, except to extent necessary for period of installation and concealment.

## PRODUCT REQUIREMENTS – SECTION 01 60 00

6. Comply with product manufacturer's written instructions for temperature, humidity, ventilation, and weather-protection requirements for storage.
7. Protect stored products from damage and liquids from freezing.
8. Provide a secure location and enclosure at Project site for storage of materials and equipment by Owner's construction forces. Coordinate location with Owner.
9. Provide bonded and insured off-site storage and protection when site does not permit on-site storage and protection.

### 1.7 PRODUCT WARRANTIES

- A. Warranties specified in other Sections shall be in addition to, and run concurrent with, other warranties required by the Contract Documents. Manufacturer's disclaimers and limitations on product warranties do not relieve Contractor of obligations under requirements of the Contract Documents.
  1. Manufacturer's Warranty: Preprinted written warranty published by individual manufacturer for a particular product and specifically endorsed by manufacturer to Owner.
  2. Special Warranty: Written warranty required by or incorporated into the Contract Documents, either to extend time limit provided by manufacturer's warranty or to provide more rights for Owner.
- B. Submittal Time: Comply with requirements in Division 1 Section 01 77 00 "Closeout Procedures."

### PART 2 - PRODUCTS (Not Used)

**SUBSTITUTION REQUEST FORM**

TO: \_\_\_\_\_ DEADLINE: 12/6/16  
Architect \_\_\_\_\_ Date \_\_\_\_\_

\_\_\_\_\_  
Street Address

\_\_\_\_\_  
City, State Zip Code

PROJECT: \_\_\_\_\_  
Project Title  
Eugene School District 4J

ITEM: \_\_\_\_\_  
Section No. Page No. Paragraph Description

The Undersigned requests consideration of the following substitution:

\_\_\_\_\_  
The Undersigned states that the following paragraphs are true, except where noted otherwise:

1. The function, appearance and quality of the proposed substitution are equivalent or superior to the specified item;
2. The proposed substitution does not affect dimensions shown on the Drawings;
3. The Undersigned will pay for changes to the building design, including engineering and design services, detailing and construction costs caused by the requested substitution;
4. The proposed substitution will have no adverse affect on other trades, the construction schedule, or specified warranty requirements;
5. Maintenance and service parts will be locally available for the proposed substitution;
6. The Undersigned has attached data concerning the proposed substitution, including: Manufacturers product description, specifications, drawings, photographs, performance and test data, adequate for evaluation of the request, with applicable portions of the data clearly indicated. Attachments also includes description of changes to Contract Documents which the proposed substitution will require for its proper installation.

Submitted by: \_\_\_\_\_ Signature: \_\_\_\_\_

Firm: \_\_\_\_\_

Address: \_\_\_\_\_

Telephone: \_\_\_\_\_ Fax: \_\_\_\_\_

Date: \_\_\_\_\_

END OF SECTION 01 60 00

**SECTION 01 78 00**  
**CLOSEOUT SUBMITTALS**

**PART 1 GENERAL**

**1.1 RELATED DOCUMENTS**

- A. Drawings and general provisions of the Contract, including other Division 1 Specification Sections, apply to this Section.

**1.2 SUMMARY**

- A. This Section includes administrative and procedural requirements for contract closeout, including, but not limited to, the following:

- 1. Project Record Documents.
- 2. Operation and Maintenance Data.
- 3. Warranties and Bonds.

- B. Related Sections include the following:

- 1. Section 01 30 00 - Administrative Requirements: Submittals procedures, shop drawings, product data, and samples.
- 2. Individual Product Sections: Specific requirements for operation and maintenance data.
- 3. Individual Product Sections: Warranties required for specific products or Work.

**1.3 SUBMITTALS**

- A. Project Record Documents: Submit documents to Architect with claim for final Application for Payment.

- B. Operation and Maintenance Data:

- 1. For equipment, or component parts of equipment put into service during construction and operated by Owner, submit completed documents within ten days after acceptance.
- 2. Submit one copy of completed documents 15 days prior to final inspection. This copy will be reviewed and returned after final inspection, with Architect comments. Revise content of all document sets as required prior to final submission.
- 3. Submit two sets of revised final documents in final form within 10 days after final inspection.

- C. Warranties and Bonds:

- 1. For equipment or component parts of equipment put into service during construction with Owner's permission, submit documents within 10 days after acceptance.
- 2. Make other submittals within 10 days after Date of Substantial Completion, prior to final Application for Payment.
- 3. For items of Work for which acceptance is delayed beyond Date of Substantial Completion, submit within 10 days after acceptance, listing the date of acceptance as the beginning of the warranty period.

**PART 2 PRODUCTS - NOT USED**

**PART 3 EXECUTION**

**3.01 PROJECT RECORD DOCUMENTS**

- A. Maintain on site one set of the following record documents; record actual revisions to the Work:

- 1. Drawings.
- 2. Specifications.
- 3. Addenda.
- 4. Change Orders and other modifications to the Contract.
- 5. Reviewed shop drawings, product data, and samples.
- 6. Manufacturer's instruction for assembly, installation, and adjusting.

- B. Ensure entries are complete and accurate, enabling future reference by Owner.

- C. Store record documents separate from documents used for construction.
- D. Record information concurrent with construction progress.
- E. Specifications: Legibly mark and record at each product section description of actual products installed, including the following:
  - 1. Manufacturer's name and product model and number.
  - 2. Product substitutions or alternates utilized.
  - 3. Changes made by Addenda and modifications.
- F. Record Drawings and Shop Drawings: Legibly mark each item to record actual construction including:
  - 1. Measured locations of internal utilities and appurtenances concealed in construction, referenced to visible and accessible features of the Work.
  - 2. Field changes of dimension and detail.
  - 3. Details not on original Contract drawings.

### 3.2 OPERATION AND MAINTENANCE MANUAL

- A. Organize operations and maintenance documents into an orderly sequence based on the table of contents of the Project Manual.
  - 1. Bind in heavy-duty, 3-ring, vinyl-covered, loose-leaf binders, thickness as necessary to accommodate contents, and sized to receive 8-1/2-by-11-inch paper.
  - 2. Provide heavy paper dividers with plastic-covered tabs for each separate warranty. Mark tab to identify the product or installation. Provide a typed description of the product or installation, including the name of the product and the name, address, and telephone number of Installer.
  - 3. Identify each binder on the front and spine with the typed or printed title "OPERATION AND MAINTENANCE MANUAL AND WARRANTIES," Project name, CIP Number, and name of Contractor.
- B. For Each Product or System: List names, addresses and telephone numbers of Subcontractors and suppliers, including local source of supplies and replacement parts.
- C. Product Data: Mark each sheet to clearly identify specific products and component parts, and data applicable to installation. Delete inapplicable information.
- D. Drawings: Supplement product data to illustrate relations of component parts of equipment and systems, to show control and flow diagrams. Do not use Project Record Documents as maintenance drawings.
- E. Typed Text: As required to supplement product data. Provide logical sequence of instructions for each procedure, incorporating manufacturer's instructions.

### 3.3 OPERATION AND MAINTENANCE DATA FOR MATERIALS AND FINISHES

- A. For Each Product, Applied Material, and Finish:
  - 1. Include paint drawdowns for colors used at each school.
- B. Instructions for Care and Maintenance: Manufacturer's recommendations for cleaning agents and methods, precautions against detrimental cleaning agents and methods, and recommended schedule for cleaning and maintenance.

### 3.5 WARRANTIES AND BONDS

- A. Obtain warranties and bonds, executed in duplicate by responsible Subcontractors, suppliers, and manufacturers, within 10 days after completion of the applicable item of work. Except for items put into use with Owner's permission, leave date of beginning of time of warranty until the Date of Substantial completion is determined.
- B. Verify that documents are in proper form, contain full information, and are notarized.
- C. Co-execute submittals when required.
- D. Retain warranties and bonds until time specified for submittal.
- E. Include warranties and bonds as a tabbed section in the O&M Manual, with typed or printed title WARRANTIES AND BONDS.

CLOSEOUT SUBMITTALS - SECTION 01 78 00

- F. Separate each warranty or bond with index tab sheets keyed to the Table of Contents listing. Provide full information, using separate typed sheets as necessary. List Subcontractor, supplier, and manufacturer, with name, address, and telephone number of responsible principal.

END OF SECTION 01 78 00

**PRODUCT REQUIREMENTS**  
**SECTION 01 60 00**

**PART 1 - GENERAL**

**1.1 RELATED DOCUMENTS**

- A. Drawings and general provisions of the Contract, including General and Supplementary Conditions and other Division 1 Specification Sections, apply to this Section.

**1.2 SUMMARY**

- A. This Section includes administrative and procedural requirements for selection of products for use in Project; product delivery, storage, and handling; manufacturers' standard warranties on products; special warranties; product substitutions; and comparable products.
- B. Related Sections include the following:
  - 1. Division 1 Section 01 77 00 "Closeout Submittals" for submitting warranties for Contract closeout.
  - 2. Divisions 2 through 49 Sections for specific requirements for warranties on products and installations specified to be warranted.

**1.3 DEFINITIONS**

- A. Products: Items purchased for incorporating into the Work, whether purchased for Project or taken from previously purchased stock. The term "product" includes the terms "material," "equipment," "system," and terms of similar intent.
- B. Substitutions: Changes in products, materials, equipment, and methods of construction from those required by the Contract Documents and proposed by Contractor.
- C. Basis-of-Design Product Specification: Where a specific manufacturer's product is named and accompanied by the words "basis of design," including make or model number or other designation, to establish the significant qualities related to type, function, dimension, in-service performance, physical properties, appearance, and other characteristics for purposes of evaluating comparable products of other named manufacturers.

**1.4 SUBMITTALS**

- A. Substitution Requests: Instructions to Bidders specify time restrictions for submitting requests for Substitutions during the bidding period, in compliance with this Section.
- B. After execution of Agreement, the Owner may, at the Owner's option, consider formal requests from the Contractor for substitution of products for those specified. One or more of the following conditions must be documented:
  - 1. Compliance with final interpretation of code requirements or insurance regulations which require that the use of a substituted Product.
  - 2. Unavailability of a specified Product through no fault of the Contractor.
  - 3. Inability of specified Product to perform properly or fit in designated place.

## PRODUCT REQUIREMENTS – SECTION 01 60 00

4. Manufacturer's or Fabricator's refusal or inability to certify or guarantee performance of a specified Product in the application intended.
- C. A Substitution Request constitutes a representation that the Bidder/Contractor:
1. Has investigated the proposed Product and determined that it meets or exceeds the quality level of the specified Product.
  2. Will provide the same warranty for the Substituted Product as for the specified Product.
  3. Will coordinate installation and make changes to the Work which may be required for the Work to be completed with no additional cost to the Owner.
  4. Waives claims for additional costs or time extension which may subsequently become apparent.
  5. Will reimburse the Owner for review or redesign services associated with re-approval by authorities.
- D. Substitutions will not be considered when they are indicated or implied on Shop Drawings or Product Data Submittals, without separate request on the form provided, or when acceptance will require revision to the Contract Documents.
- E. Submit three copies of each request for consideration. Limit each request to one proposed Substitution. Identify product or fabrication or installation method to be replaced. Include Specification Section number and title and Drawing numbers and titles.
1. Substitution Request Form: Use form provided at end of Section.
  2. Documentation: Show compliance with requirements for substitutions and the following, as applicable:
    - a. Statement indicating why specified material or product cannot be provided.
    - b. Coordination information, including a list of changes or modifications needed to other parts of the Work and to construction performed by Owner and separate contractors, that will be necessary to accommodate proposed substitution.
    - c. Detailed comparison of significant qualities of proposed substitution with those of the Work specified. Significant qualities may include attributes such as performance, weight, size, durability, visual effect, and specific features and requirements indicated.
    - d. Product Data, including drawings and descriptions of products and fabrication and installation procedures.
    - e. Provide MSDS information to confirm that the product is no more harmful than the products specified.
    - f. Samples, where applicable or requested.
    - g. List of similar installations for completed projects with project names and addresses and names and addresses of architects and owners.
    - h. Material test reports from a qualified testing agency indicating and interpreting test results for compliance with requirements indicated.
    - i. Research/evaluation reports evidencing compliance with building code in effect for Project, from a model code organization acceptable to authorities having jurisdiction.
    - j. Detailed comparison of Contractor's Construction Schedule using proposed substitution with products specified for the Work, including effect on the overall Contract Time. If specified product or method of construction cannot be provided within the Contract Time, include letter from manufacturer, on manufacturer's letterhead, stating lack of availability or delays in delivery.



## PRODUCT REQUIREMENTS – SECTION 01 60 00

- k. Cost information, including a proposal of change, if any, in the Contract Sum.
  - l. Contractor's certification that proposed substitution complies with requirements in the Contract Documents and is appropriate for applications indicated.
  - m. Contractor's waiver of rights to additional payment or time that may subsequently become necessary because of failure of proposed substitution to produce indicated results.
3. Architect's Action: If necessary, Architect will request additional information or documentation for evaluation within 7 days of receipt of a request for substitution. Architect will notify Contractor of acceptance or rejection of proposed substitution within 15 days of receipt of request, or 7 days of receipt of additional information or documentation, whichever is later.
- a. Form of Acceptance: Change Order.
  - b. Use product specified if Architect cannot make a decision on use of a proposed substitution within time allocated.

### 1.5 QUALITY ASSURANCE

- A. Compatibility of Options: If Contractor is given option of selecting between two or more products for use on Project, product selected shall be compatible with products previously selected, even if previously selected products were also options.

### 1.6 PRODUCT DELIVERY, STORAGE, AND HANDLING

- A. Deliver, store, and handle products using means and methods that will prevent damage, deterioration, and loss, including theft. Comply with manufacturer's written instructions.
- B. Delivery and Handling:
  - 1. Schedule delivery to minimize long-term storage at Project site and to prevent overcrowding of construction spaces.
  - 2. Coordinate delivery with installation time to ensure minimum holding time for items that are flammable, hazardous, easily damaged, or sensitive to deterioration, theft, and other losses.
  - 3. Deliver products to Project site in an undamaged condition in manufacturer's original sealed container or other packaging system, complete with labels and instructions for handling, storing, unpacking, protecting, and installing.
  - 4. Inspect products on delivery to ensure compliance with the Contract Documents and to ensure that products are undamaged and properly protected.
- C. Storage:
  - 1. Store products to allow for inspection and measurement of quantity or counting of units.
  - 2. Store materials in a manner that will not endanger Project structure.
  - 3. Store products that are subject to damage by the elements, under cover in a weathertight enclosure above ground, with ventilation adequate to prevent condensation.
  - 4. Store cementitious products and materials on elevated platforms.
  - 5. Store foam plastic from exposure to sunlight, except to extent necessary for period of installation and concealment.

## PRODUCT REQUIREMENTS – SECTION 01 60 00

6. Comply with product manufacturer's written instructions for temperature, humidity, ventilation, and weather-protection requirements for storage.
7. Protect stored products from damage and liquids from freezing.
8. Provide a secure location and enclosure at Project site for storage of materials and equipment by Owner's construction forces. Coordinate location with Owner.
9. Provide bonded and insured off-site storage and protection when site does not permit on-site storage and protection.

### 1.7 PRODUCT WARRANTIES

- A. Warranties specified in other Sections shall be in addition to, and run concurrent with, other warranties required by the Contract Documents. Manufacturer's disclaimers and limitations on product warranties do not relieve Contractor of obligations under requirements of the Contract Documents.
  1. Manufacturer's Warranty: Preprinted written warranty published by individual manufacturer for a particular product and specifically endorsed by manufacturer to Owner.
  2. Special Warranty: Written warranty required by or incorporated into the Contract Documents, either to extend time limit provided by manufacturer's warranty or to provide more rights for Owner.
- B. Submittal Time: Comply with requirements in Division 1 Section 01 77 00 "Closeout Procedures."

### PART 2 - PRODUCTS (Not Used)

**SUBSTITUTION REQUEST FORM**

TO: \_\_\_\_\_ DEADLINE: 12/6/16  
Architect \_\_\_\_\_ Date \_\_\_\_\_

\_\_\_\_\_  
Street Address

\_\_\_\_\_  
City, State Zip Code

PROJECT: \_\_\_\_\_  
Project Title  
Eugene School District 4J

ITEM: \_\_\_\_\_  
Section No. Page No. Paragraph Description

The Undersigned requests consideration of the following substitution:

\_\_\_\_\_  
The Undersigned states that the following paragraphs are true, except where noted otherwise:

1. The function, appearance and quality of the proposed substitution are equivalent or superior to the specified item;
2. The proposed substitution does not affect dimensions shown on the Drawings;
3. The Undersigned will pay for changes to the building design, including engineering and design services, detailing and construction costs caused by the requested substitution;
4. The proposed substitution will have no adverse affect on other trades, the construction schedule, or specified warranty requirements;
5. Maintenance and service parts will be locally available for the proposed substitution;
6. The Undersigned has attached data concerning the proposed substitution, including: Manufacturers product description, specifications, drawings, photographs, performance and test data, adequate for evaluation of the request, with applicable portions of the data clearly indicated. Attachments also includes de-scription of changes to Contract Documents which the proposed substitution will require for its proper installation.

Submitted by: \_\_\_\_\_ Signature: \_\_\_\_\_

Firm: \_\_\_\_\_

Address: \_\_\_\_\_

Telephone: \_\_\_\_\_ Fax: \_\_\_\_\_

Date: \_\_\_\_\_

END OF SECTION 01 60 00

**SECTION 01 78 00**  
**CLOSEOUT SUBMITTALS**

**PART 1 GENERAL**

**1.1 RELATED DOCUMENTS**

- A. Drawings and general provisions of the Contract, including other Division 1 Specification Sections, apply to this Section.

**1.2 SUMMARY**

- A. This Section includes administrative and procedural requirements for contract closeout, including, but not limited to, the following:

- 1. Project Record Documents.
- 2. Operation and Maintenance Data.
- 3. Warranties and Bonds.

- B. Related Sections include the following:

- 1. Section 01 30 00 - Administrative Requirements: Submittals procedures, shop drawings, product data, and samples.
- 2. Individual Product Sections: Specific requirements for operation and maintenance data.
- 3. Individual Product Sections: Warranties required for specific products or Work.

**1.3 SUBMITTALS**

- A. Project Record Documents: Submit documents to Architect with claim for final Application for Payment.

- B. Operation and Maintenance Data:

- 1. For equipment, or component parts of equipment put into service during construction and operated by Owner, submit completed documents within ten days after acceptance.
- 2. Submit one copy of completed documents 15 days prior to final inspection. This copy will be reviewed and returned after final inspection, with Architect comments. Revise content of all document sets as required prior to final submission.
- 3. Submit two sets of revised final documents in final form within 10 days after final inspection.

- C. Warranties and Bonds:

- 1. For equipment or component parts of equipment put into service during construction with Owner's permission, submit documents within 10 days after acceptance.
- 2. Make other submittals within 10 days after Date of Substantial Completion, prior to final Application for Payment.
- 3. For items of Work for which acceptance is delayed beyond Date of Substantial Completion, submit within 10 days after acceptance, listing the date of acceptance as the beginning of the warranty period.

**PART 2 PRODUCTS - NOT USED**

**PART 3 EXECUTION**

**3.01 PROJECT RECORD DOCUMENTS**

- A. Maintain on site one set of the following record documents; record actual revisions to the Work:

- 1. Drawings.
- 2. Specifications.
- 3. Addenda.
- 4. Change Orders and other modifications to the Contract.
- 5. Reviewed shop drawings, product data, and samples.
- 6. Manufacturer's instruction for assembly, installation, and adjusting.

- B. Ensure entries are complete and accurate, enabling future reference by Owner.

- C. Store record documents separate from documents used for construction.
- D. Record information concurrent with construction progress.
- E. Specifications: Legibly mark and record at each product section description of actual products installed, including the following:
  - 1. Manufacturer's name and product model and number.
  - 2. Product substitutions or alternates utilized.
  - 3. Changes made by Addenda and modifications.
- F. Record Drawings and Shop Drawings: Legibly mark each item to record actual construction including:
  - 1. Measured locations of internal utilities and appurtenances concealed in construction, referenced to visible and accessible features of the Work.
  - 2. Field changes of dimension and detail.
  - 3. Details not on original Contract drawings.

### 3.2 OPERATION AND MAINTENANCE MANUAL

- A. Organize operations and maintenance documents into an orderly sequence based on the table of contents of the Project Manual.
  - 1. Bind in heavy-duty, 3-ring, vinyl-covered, loose-leaf binders, thickness as necessary to accommodate contents, and sized to receive 8-1/2-by-11-inch paper.
  - 2. Provide heavy paper dividers with plastic-covered tabs for each separate warranty. Mark tab to identify the product or installation. Provide a typed description of the product or installation, including the name of the product and the name, address, and telephone number of Installer.
  - 3. Identify each binder on the front and spine with the typed or printed title "OPERATION AND MAINTENANCE MANUAL AND WARRANTIES," Project name, CIP Number, and name of Contractor.
- B. For Each Product or System: List names, addresses and telephone numbers of Subcontractors and suppliers, including local source of supplies and replacement parts.
- C. Product Data: Mark each sheet to clearly identify specific products and component parts, and data applicable to installation. Delete inapplicable information.
- D. Drawings: Supplement product data to illustrate relations of component parts of equipment and systems, to show control and flow diagrams. Do not use Project Record Documents as maintenance drawings.
- E. Typed Text: As required to supplement product data. Provide logical sequence of instructions for each procedure, incorporating manufacturer's instructions.

### 3.3 OPERATION AND MAINTENANCE DATA FOR MATERIALS AND FINISHES

- A. For Each Product, Applied Material, and Finish:
  - 1. Include paint drawdowns for colors used at each school.
- B. Instructions for Care and Maintenance: Manufacturer's recommendations for cleaning agents and methods, precautions against detrimental cleaning agents and methods, and recommended schedule for cleaning and maintenance.

### 3.5 WARRANTIES AND BONDS

- A. Obtain warranties and bonds, executed in duplicate by responsible Subcontractors, suppliers, and manufacturers, within 10 days after completion of the applicable item of work. Except for items put into use with Owner's permission, leave date of beginning of time of warranty until the Date of Substantial completion is determined.
- B. Verify that documents are in proper form, contain full information, and are notarized.
- C. Co-execute submittals when required.
- D. Retain warranties and bonds until time specified for submittal.
- E. Include warranties and bonds as a tabbed section in the O&M Manual, with typed or printed title WARRANTIES AND BONDS.

CLOSEOUT SUBMITTALS - SECTION 01 78 00

- F. Separate each warranty or bond with index tab sheets keyed to the Table of Contents listing. Provide full information, using separate typed sheets as necessary. List Subcontractor, supplier, and manufacturer, with name, address, and telephone number of responsible principal.

END OF SECTION 01 78 00



Facilities Management  
 School District 4J  
 715 W. 4th Avenue  
 Eugene, OR 97402  
 (541) 790-7400

SOUTH EUGENE HIGH SCHOOL  
 400 EAST 19th AVENUE 97401  
 SOFTBALL SCOREBOARD INSTALLATION

DATE: NOV. 21, 2016  
 REVISION:

DRAWN: M. HEFFERNAN

SHEET

A1

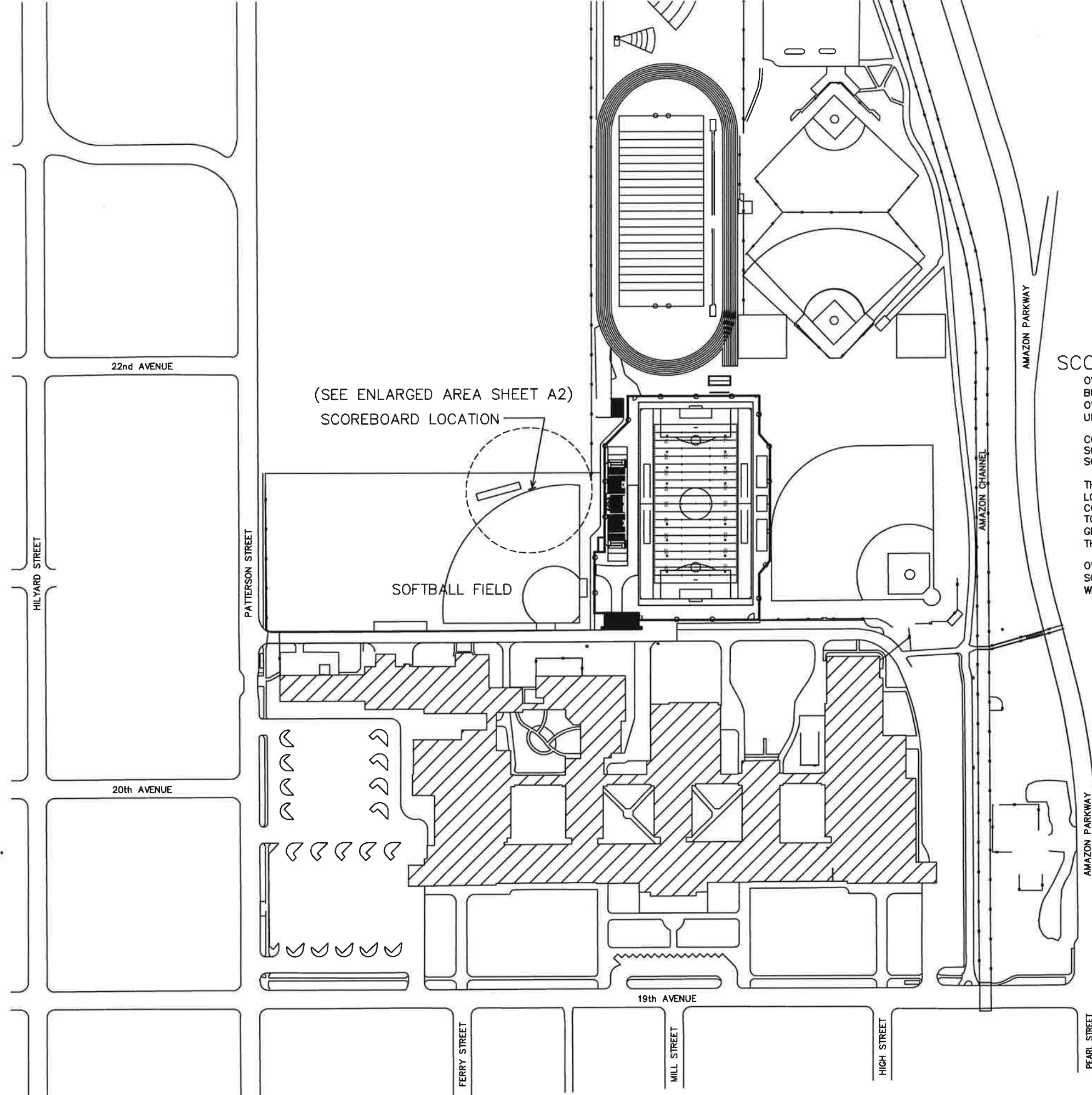

(SEE ENLARGED AREA SHEET A2)  
 SCOREBOARD LOCATION

SOFTBALL FIELD

**SCOPE OF WORK**

OWNER HAS PURCHASED A NEW SCOREBOARD. (CURRENTLY IN THE ORIGINAL BOX INSIDE OF BUILDING.)  
 OWNER HAS ALSO PURCHASED THE (2) STEEL I-BEAMS FOR THE SCOREBOARD UPRIGHT SUPPORTS. (CURRENTLY LOCATED BEHIND THE FOOTBALL BLEACHERS.)

CONTRACTOR SHALL DRILL APPROPRIATE HOLES IN STEEL I-BEAMS FOR ATTACHING UNISTRUT & SCOREBOARD. I-BEAMS NEED TO BE PRIMED & PAINTED TO MATCH EXISTING FOOTBALL SCOREBOARD UPRIGHT SUPPORTS.

THERE EXISTS AN EMPTY CONDUIT FROM THE TRACK HOUSE BUILDING (NEAR THE POWER LOCATION) OUT TO AN APPROXIMATE LOCATION NEAR THE PROPOSED SCOREBOARD. CONTRACTOR SHALL EXTEND THIS CONDUIT UP THROUGH THE NEW FOOTINGS FOR CONNECTING TO SCOREBOARD. OWNER WILL INSTALL METAL CONDUIT ON SUPPORTS FROM PVC INSERT AT GROUND LEVEL TO SCOREBOARD & PROVIDE/PULL WIRE TO COMPLETE THE POWER WIRING OF THE SCOREBOARD. (ALL DATA ASSOCIATED WITH THE SCOREBOARD IS WIRELESS.)

OWNER IS PLANNING TO ADD FUTURE ROSTER BOARDS ON FUTURE STRUTS ABOVE & BELOW THE SCOREBOARD AS SHOWN ON THE STRUCTURAL DRAWING. (THESE STRUTS WILL BE BY OWNER & WILL NOT NEED TO HAVE HOLES DRILLED IN THE UPRIGHT SUPPORTS.)

**DRAWING INDEX**

- A1 COVER / SITE PLAN
- A2 ENLARGED LOCATION PLAN
- S1 STRUCTURAL PLAN, ELEVATION, & SUPPORT DETAILS

**OWNER**

SCHOOL DISTRICT 4J  
 715 W. 4TH AVENUE  
 EUGENE, OREGON 97402

CONTACT:  
 MICHAEL HEFFERNAN, ARCHITECT  
 TEL: (541) 790-7405 OR  
 CELL (512) 547-9550  
 HEFFERNAN\_M@J.LANE.EDU



1 SITE PLAN  
 SCALE: 1" = 200'-0"



Facilities  
Management  
School District 4J  
715 W. 4th Avenue  
Eugene, OR 97402  
(541) 790-7414

SOUTH EUGENE HIGH SCHOOL  
400 E 19TH AVENUE EUGENE 97404-2299  
SOFTBALL SCOREBOARD INSTALLATION

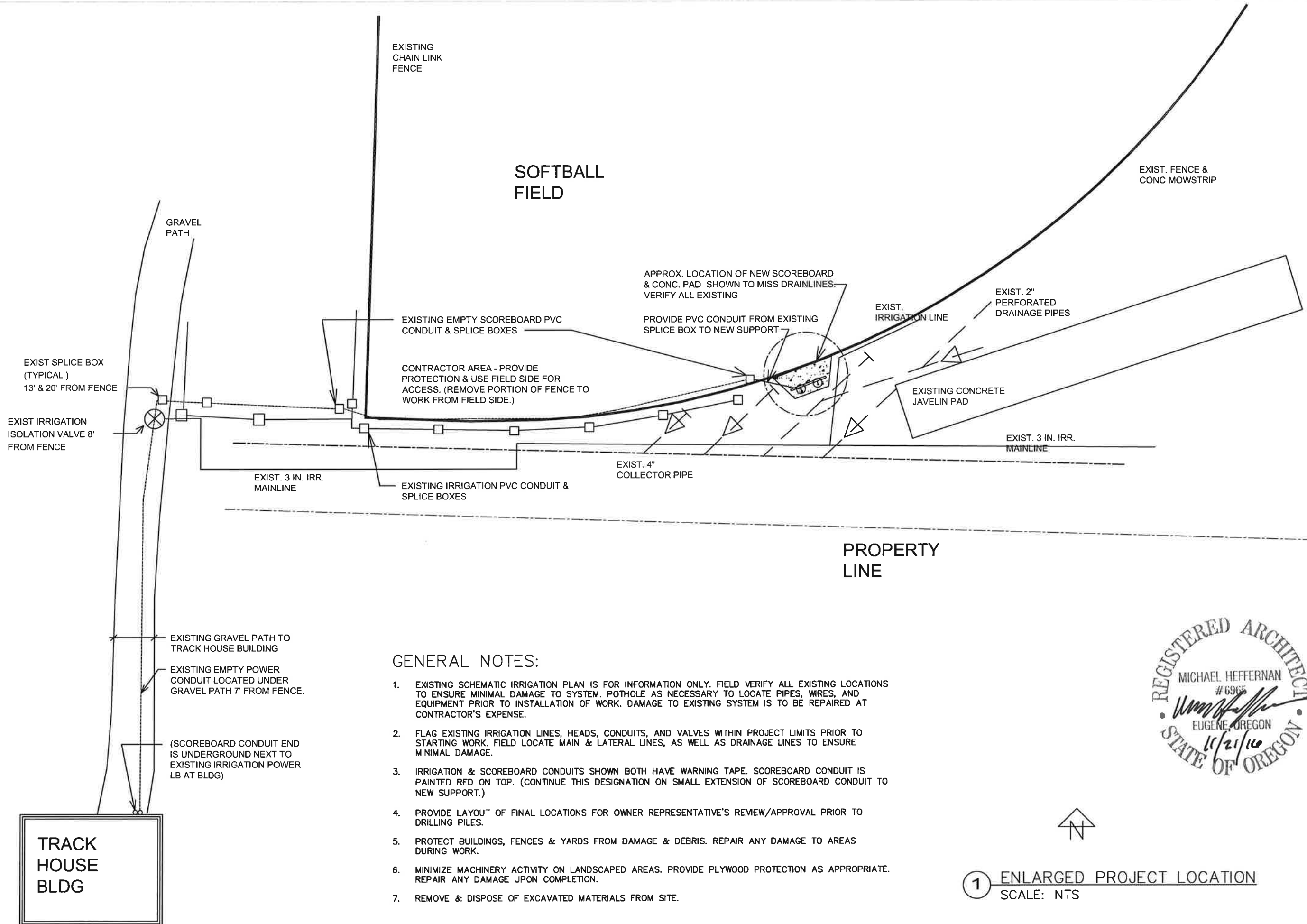

**GENERAL NOTES:**

1. EXISTING SCHEMATIC IRRIGATION PLAN IS FOR INFORMATION ONLY. FIELD VERIFY ALL EXISTING LOCATIONS TO ENSURE MINIMAL DAMAGE TO SYSTEM. POTHOLE AS NECESSARY TO LOCATE PIPES, WIRES, AND EQUIPMENT PRIOR TO INSTALLATION OF WORK. DAMAGE TO EXISTING SYSTEM IS TO BE REPAIRED AT CONTRACTOR'S EXPENSE.
2. FLAG EXISTING IRRIGATION LINES, HEADS, CONDUITS, AND VALVES WITHIN PROJECT LIMITS PRIOR TO STARTING WORK. FIELD LOCATE MAIN & LATERAL LINES, AS WELL AS DRAINAGE LINES TO ENSURE MINIMAL DAMAGE.
3. IRRIGATION & SCOREBOARD CONDUITS SHOWN BOTH HAVE WARNING TAPE. SCOREBOARD CONDUIT IS PAINTED RED ON TOP. (CONTINUE THIS DESIGNATION ON SMALL EXTENSION OF SCOREBOARD CONDUIT TO NEW SUPPORT.)
4. PROVIDE LAYOUT OF FINAL LOCATIONS FOR OWNER REPRESENTATIVE'S REVIEW/APPROVAL PRIOR TO DRILLING PILES.
5. PROTECT BUILDINGS, FENCES & YARDS FROM DAMAGE & DEBRIS. REPAIR ANY DAMAGE TO AREAS DURING WORK.
6. MINIMIZE MACHINERY ACTIVITY ON LANDSCAPED AREAS. PROVIDE PLYWOOD PROTECTION AS APPROPRIATE. REPAIR ANY DAMAGE UPON COMPLETION.
7. REMOVE & DISPOSE OF EXCAVATED MATERIALS FROM SITE.



1 ENLARGED PROJECT LOCATION  
SCALE: NTS

DRAWN: M.HEFFERNAN

SHEET

A2

DATE: NOV. 21, 2016  
REVISION:

TRACK  
HOUSE  
BLDG



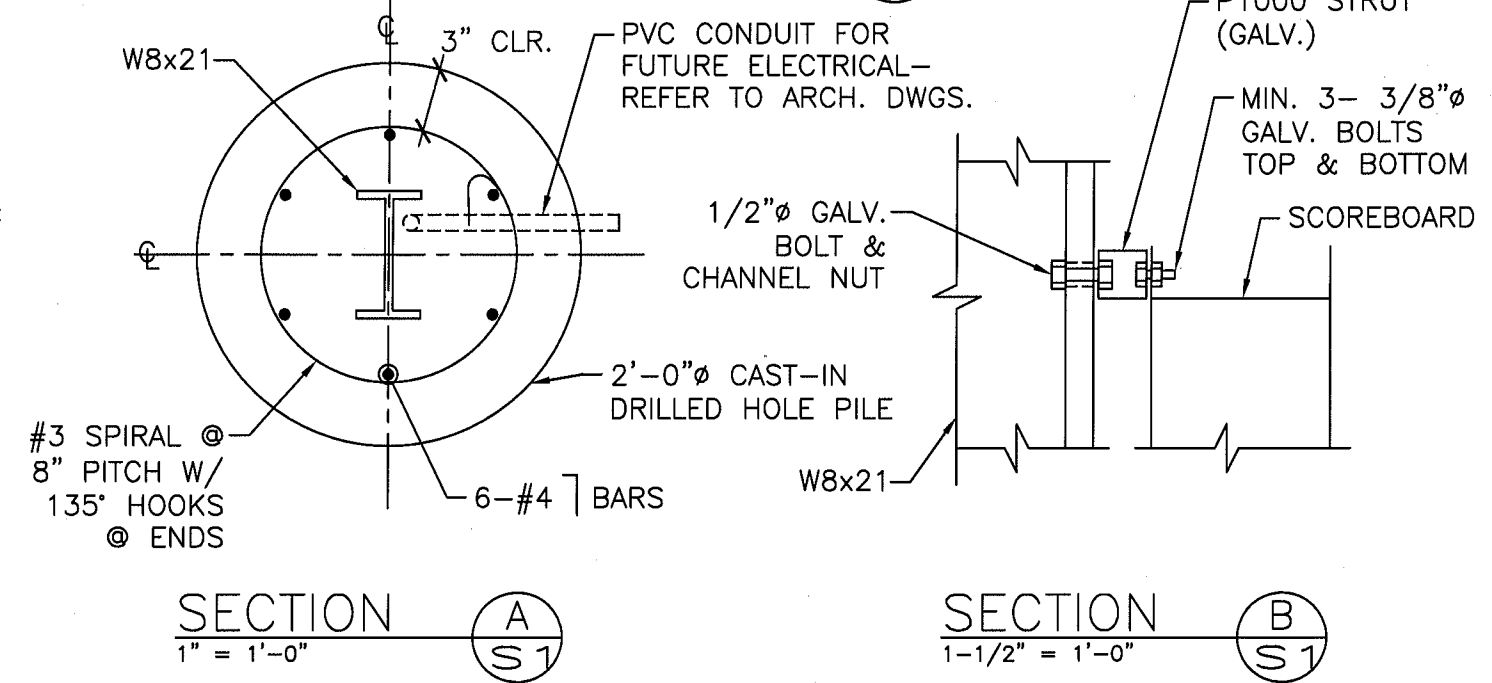
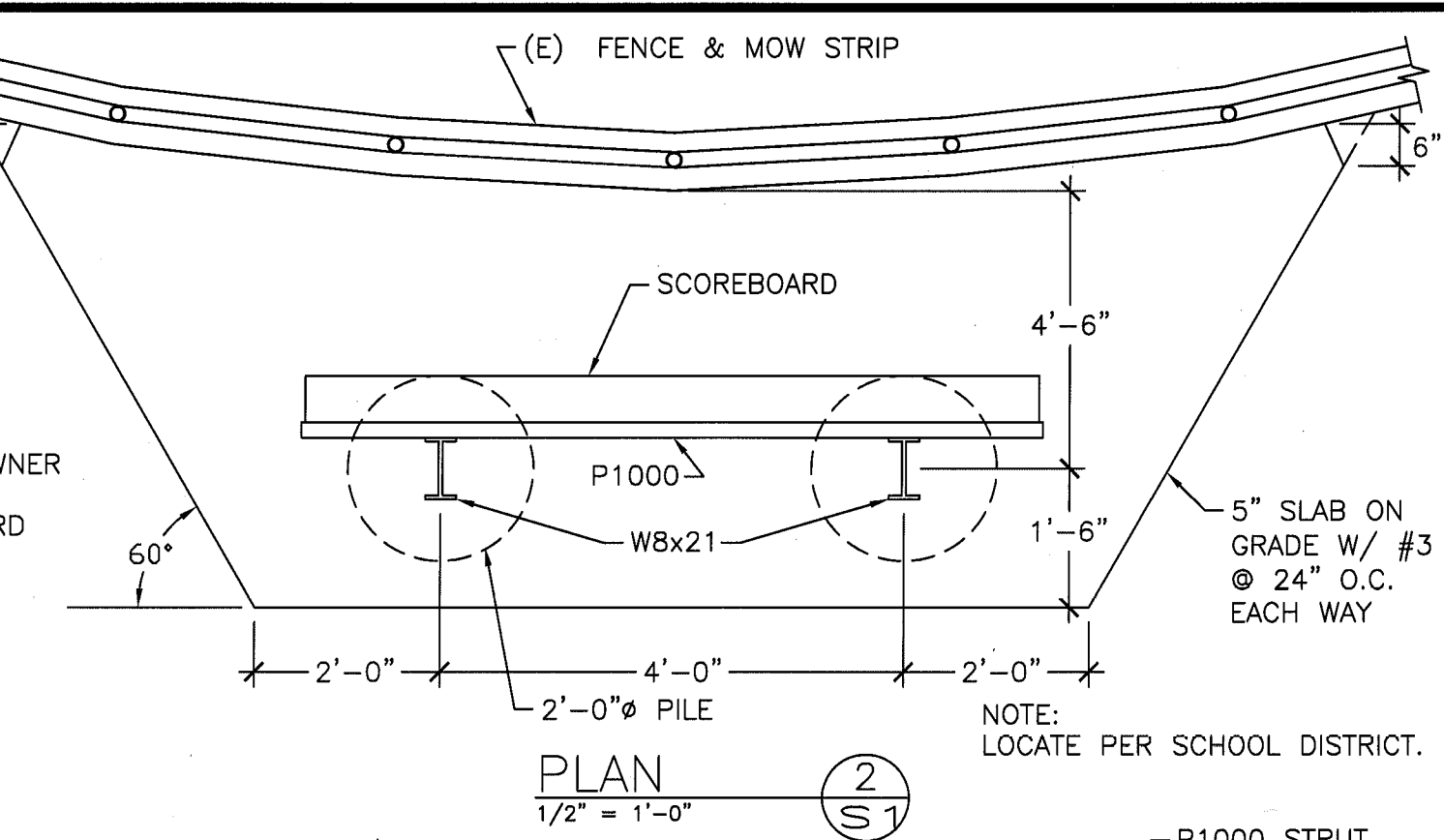
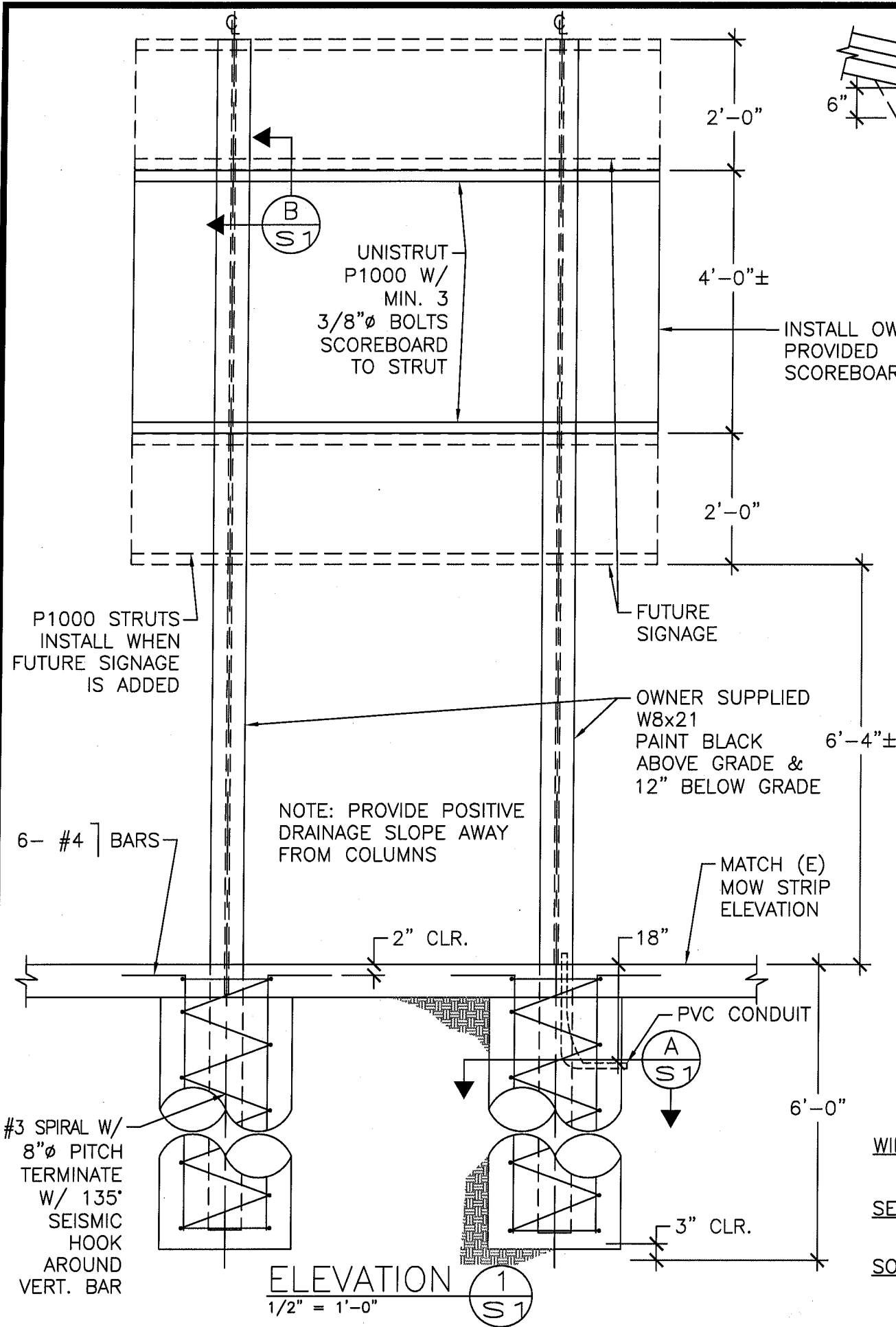

**DESIGN DATA**

**WIND:**  
VULT= 120mph VASD= 93mph EXPOSURE B  
PULT= 42psf

**SEISMIC:** SEISMIC DESIGN  
CATEGORY: D  
SITE CLASS: D (ASSUMED)

**SOILS:**  
BEARING= 1,500psi (ASSUMED)

**CONCRETE:** 3,000psi W/C= 0.50 MAX.  
ENTRAINED AIR: 4%±1.5%

**STEEL:** ASTM A-615 40ksi

**BOLTS:** ASTM A-307 GALVANIZED

**HARDWARE:** MANUFACTURED BY UNISTRUT, GALVANIZED FOR EXTERIOR USE.

REGISTERED PROFESSIONAL ENGINEER  
19814  
OREGON  
SCOTT A. METZLER  
SEPT. 17, 1981

EXPIRES 12/31/2016

**METZLER ENGINEERING GROUP**

220 E. 11th Avenue, Suite #3 EUGENE, OR  
Ph: (541) 344-2040 Fax: (541) 344-1821

**PLAN, ELEVATION & SUPPORT DETAILS**

SEHS SOFTBALL SCOREBOARD SUPPORTS  
400 E 19th AVENUE  
EUGENE, OREGON 97401

CAD FILE  
4J-SEHS-SoftB.DWG

DRAWN BY  
KDL

REVIEWED BY  
SAM

DATE  
11/02/16

SCALE  
AS SHOWN

SHEET NUMBER  
S1

1 of 1