

EUGENE SCHOOL DISTRICT 4J
MULTISITE DECOMMISSION OIL TANKS 2015

CIP: 420.780.020



Roberts Consulting
& Engineering, Inc.

3220 Tilden St. Eugene, Or 97404
Office: 541-689-9197
Fax: 541-461-5443
bjr@rceinc.net

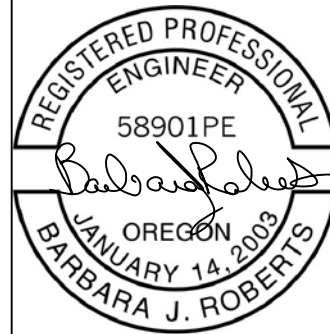

EXPIRATION DATE: 12/31/2016



VICINITY MAP
NO SCALE

SHEET INDEX

- 1.0 DRAWING INDEX, VICINITY MAP
- 1.1 GENERAL NOTES
- 1.2 LEGEND & DETAILS

SITE & TANK REMOVAL PLANS

- 2.0 & 2.1 ADAMS ELEMENTARY SCHOOL
- 3.0 & 3.1 BAILEY HILL INSTRUCTIONAL CENTER
- 4.0 & 4.1 CHURCHILL HIGH SCHOOL
- 5.0 & 5.1 EDISON ELEMENTARY SCHOOL
- 6.0 & 6.1 KELLY MIDDLE SCHOOL
- 7.0 & 7.1 MEADOWLARK ELEMENTARY SCHOOL
- 8.0 & 8.1 TWIN OAKS ELEMENTARY SCHOOL

CONTACTS

OWNER'S REPRESENTATIVE:
KIRK GEBB
EUGENE SCHOOL DISTRICT 4J
715 E. 4TH AVE
EUGENE, OR 97402
TEL (541) 790-7431
FAX (541) 790-7420
GEBB@4J.LANE.EDU

CIVIL ENGINEER:
BARBARA ROBERTS, P.E.
ROBERTS CONSULTING & ENGINEERING
3220 TILDEN STREET, SUITE A
EUGENE, OREGON 97404
TEL (541) 689-9197
FAX (541) 461-5443
BJR@RCEINC.NET



Facilities
Management
School District 4J
715 W. 4th Avenue
Eugene, OR 97402
(541) 687-3257

MULTISITE
DECOMMISSION OIL
TANKS 2015

DRAWING INDEX,
VICINITY MAP

PROJECT NO: 141602
DRAWN: BJR
CHECKED: BJR

DATE: 04/07/15

SHEET:

1.0 OF 17

GENERAL NOTES:

1. EXISTING SITE LAYOUT IS FROM GOOGLE EARTH.

2. CONTRACTOR TO NOTIFY ALL UTILITY COMPANIES A MINIMUM OF 48 BUSINESS HOURS (2 BUSINESS DAYS) PRIOR TO START OF CONSTRUCTION, AND COMPLY WITH ALL OTHER REQUIREMENTS OF ORS 757.541 TO 757.571

3. ANY INSPECTION BY THE CITY OR OTHER AGENCIES SHALL NOT, IN ANY WAY, RELIEVE THE CONTRACTOR FROM ANY OBLIGATIONS TO PERFORM THE WORK IN STRICT COMPLIANCE WITH THE APPLICABLE CODES AND AGENCY REQUIREMENTS.

4. CONTRACTOR SHALL ERECT AND MAINTAIN BARRICADES, WARNING SIGNS, TRAFFIC CONES PER CITY AND OWNER REQUIREMENTS IN ACCORDANCE WITH THE MUTCD (INCLUDING OREGON AMENDMENTS). ACCESS TO DRIVEWAYS AND BUILDINGS SHALL BE MAINTAINED AT ALL TIMES FOR FIRE AND EMERGENCY VEHICLES. ALL TRAFFIC CONTROL MEASURES SHALL BE APPROVED AND IN PLACE PRIOR TO ANY CONSTRUCTION ACTIVITY.

5. RECORD DRAWINGS. THE CONTRACTOR SHALL MAINTAIN ONE COMPLETE SET OF APPROVED DRAWINGS ON THE CONSTRUCTION SITE AT ALL TIMES WHEREON HE WILL RECORD ANY APPROVED DEVIATIONS IN CONSTRUCTION FROM THE APPROVED DRAWINGS, AS WELL AS THE LOCATIONS AND DEPTHS OF ALL EXISTING UTILITIES ENCOUNTERED. THESE FIELD RECORD DRAWINGS SHALL BE KEPT UP TO DATE AT ALL TIMES AND SHALL BE AVAILABLE FOR INSPECTION BY THE OWNER/ENGINEER UPON REQUEST.

6. UPON COMPLETION OF CONSTRUCTION, CONTRACTOR SHALL SUBMIT A CLEAN SET OF FIELD RECORD DRAWINGS CONTAINING ALL AS-BUILT INFORMATION TO THE OWNER.

EXISTING UTILITIES & FACILITIES.

7. THE LOCATION OF EXISTING UTILITIES ARE NOT SHOWN ON THE DRAWINGS. CONTRACTOR SHALL FIELD LOCATE ALL EXISTING UTILITIES PRIOR TO CONSTRUCTION.

8. ALL EXISTING FACILITIES SHALL BE MAINTAINED IN-PLACE BY THE CONTRACTOR UNLESS OTHERWISE SHOWN OR DIRECTED. CONTRACTOR SHALL TAKE ALL PRECAUTIONS NECESSARY TO SUPPORT, MAINTAIN, OR OTHERWISE PROTECT EXISTING UTILITIES AND OTHER FACILITIES AT ALL TIMES DURING CONSTRUCTION. CONTRACTOR TO LEAVE EXISTING UTILITIES IN AN EQUAL OR BETTER-THAN-ORIGINAL CONDITION AND TO THE SATISFACTION OF THE ENGINEER.

9. ATTENTION: OREGON LAW REQUIRES YOU TO FOLLOW RULES ADOPTED BY THE OREGON UTILITY NOTIFICATION CENTER. THOSE RULES ARE SET FORTH IN OAR 952-001-00100 THROUGH OAR 952-001-0090. YOU MAY OBTAIN COPIES OF THE RULES BY CALLING THE CENTER. (NOTE: THE TELEPHONE NUMBER FOR THE OREGON UTILITY NOTIFICATION CENTER IS (503) 232-1987 OR 1-800-332-2344)

10. THE CONTRACTOR SHALL LOCATE AND MARK ALL EXISTING PROPERTY AND STREET MONUMENTS PRIOR TO CONSTRUCTION. ANY MONUMENTS DISTURBED DURING CONSTRUCTION OF THE PROJECT SHALL BE REPLACED BY A REGISTERED LAND SURVEYOR AT THE CONTRACTOR'S EXPENSE. THE MONUMENTS SHALL BE REPLACED WITHIN A MAXIMUM OF 14 DAYS, AND THE COUNTY SURVEYOR SHALL BE NOTIFIED IN WRITING AS REQUIRED BY ORS 209.150.

11. UTILITIES, OR INTERFERING PORTIONS OF UTILITIES, THAT ARE ABANDONED IN PLACE SHALL BE REMOVED BY THE CONTRACTOR TO THE EXTENT NECESSARY TO ACCOMPLISH THE WORK. THE CONTRACTOR SHALL PLUG THE REMAINING EXPOSED ENDS OF ABANDONED UTILITIES.

12. CONTRACTOR SHALL REMOVE ALL EXISTING SIGNS, MAILBOXES, FENCES, LANDSCAPING, ETC., AS REQUIRED TO AVOID DAMAGE DURING CONSTRUCTION AND REPLACE THEM TO EXISTING OR BETTER CONDITION.

GRADING, PAVING, & DRAINAGE:

13. FINISH PAVEMENT GRADES AT TRANSITION TO EXISTING PAVEMENT SHALL MATCH EXISTING PAVEMENT GRADES OR BE FEATHERED PAST JOINTS WITH EXISTING PAVEMENT AS REQUIRED TO PROVIDE A SMOOTH, FREE DRAINING SURFACE.

14. ALL EXISTING OR CONSTRUCTED MANHOLES, CLEANOUTS, MONUMENTS, GAS VALVES, WATER VALVES AND SIMILAR STRUCTURES SHALL BE ADJUSTED TO MATCH FINISH GRADE OF THE PAVEMENT WHEREIN THEY LIE.

15. DRIVEWAYS SHALL BE CONSTRUCTED TO THE FULL THICKNESS SHOWN.

SITE PLAN NOTES:

1. WORK LOCATIONS AND DIMENSIONS ARE ESTIMATES. ACTUAL LIMITS TO BE LOCATED IN THE FIELD BY THE ENGINEER.

2. WORK AREAS GIVEN INDICATES EXCAVATION AREA 10 FEET BEYOND THE EXISTING OIL TANK DIMENSIONS. TANK REMOVAL AND DECOMMISSIONING TO BE IN ACCORDANCE WITH DEQ REQUIREMENTS AND CONTRACT SPECIFICATIONS. HOLE TO BE FILLED SAME DAY SAME DAY TANK IS REMOVED.

3. DECOMMISSION AS INDICATED ON DRAWINGS. DECOMMISSION BY FILLING IN-PLACE: DECOMMISSIONING UNDERGROUND STORAGE TANKS BY FILLING THEM IN PLACE WITH INERT MATERIAL. DECOMMISSION BY REMOVAL: DECOMMISSIONING UNDERGROUND STORAGE TANKS BY REMOVING THEM.

3. CONCRETE ANCHORAGE BELOW TANKS TO REMAIN. REMOVE ALL CONCRETE ANCHORS AND MATERIALS THAT ARE ABOVE THE TANKS.

4. CATHODIC PROTECTION AT ALL SITES: CONTRACTOR TO REMOVE CONDUIT, WIRE AND EQUIPMENT UP TO THE BUILDING.

5. REMOVE AND REPLACE ALL SURFACE HARDSCAPE AND LANDSCAPE AREAS WITHIN REMOVAL LIMITS, AS SHOWN ON THE DRAWINGS.

6. ALL SURFACES TO BE RESTORED TO THE EXISTING GRADES AND ELEVATIONS.

7. STORM DRAIN INLET PROTECTION SHALL BE INSTALLED ADJACENT TO PAVEMENT REPAIRS AND PAVEMENT REMOVALS PRIOR TO SAW CUTTING AND EXCAVATION. BIO BAGS MAY BE USED AS INLET PROTECTION IN GUTTERS BETWEEN THE WORK AND THE INLETS OR CATCH BASINS. INLET PROTECTION SHALL REMAIN IN PLACE UNTIL THE WORK IS COMPLETED. INLET AND CATCH BASINS ARE NOT IDENTIFIED ON THE PLANS.

8. REPAINT ALL PARKING LOT PAVEMENT MARKINGS AND CURBS IN WORK AREAS. COORDINATE WITH OWNER FOR PAINT COLORS.

- RE-STRIPE PARKING SPACES AND ISLANDS WITH 4" WIDE PAINTED STRIPES (WHITE) TO EXISTING DIMENSIONS.
- STRIPE ADA PARKING SPACES AND AISLE SPACE TO EXISTING DIMENSIONS. PAINT 36"X36" ACCESSIBLE PARKING SYMBOL (WHITE ON BLUE BACKGROUND) IN EACH PARKING SPACE. PAINT "NO PARKING" (1' HIGH WHITE LETTERS) IN AISLE SPACE AND 4" WIDE PAINTED STRIPES AT 12"O.C.
- NO PARKING AREA. ISLAND STRIPING TO BE 4" WIDE PAINTED STRIPES AT 12" O.C. WITH 4" WIDE STRIPE AROUND THE ISLAND PERIMETER.



3220 Tilden St. Eugene, Or 97404
Office: 541-689-9197
Fax: 541-463-5493
bjr@rcengin.com

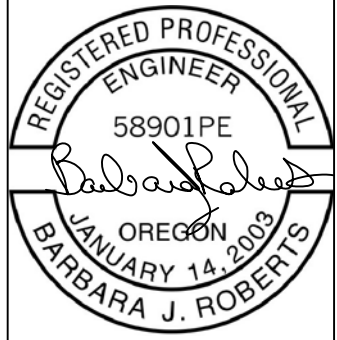

EXPIRATION DATE: 12/31/2016

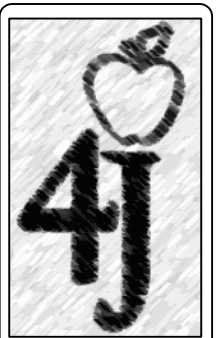

Facilities Management
School District 4J
715 W. 4th Avenue
Eugene, OR 97402
(541) 687-3257

MULTISITE
DECOMMISSION OIL
TANKS 2015

GENERAL NOTES

PROJECT NO: 141602
DRAWN: BJR
CHECKED: BJR

DATE: 04/07/15

SHEET:

1.1 OF 17

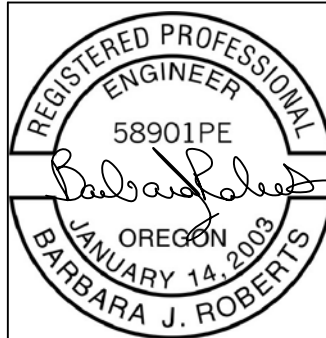

EXPIRATION DATE: 12/31/2016

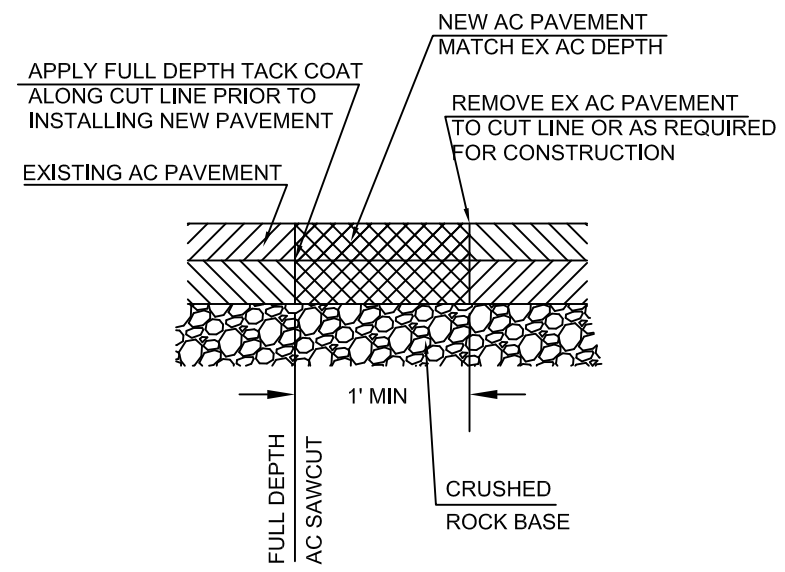

1 TYPICAL SAWCUT SECTION
NO SCALE

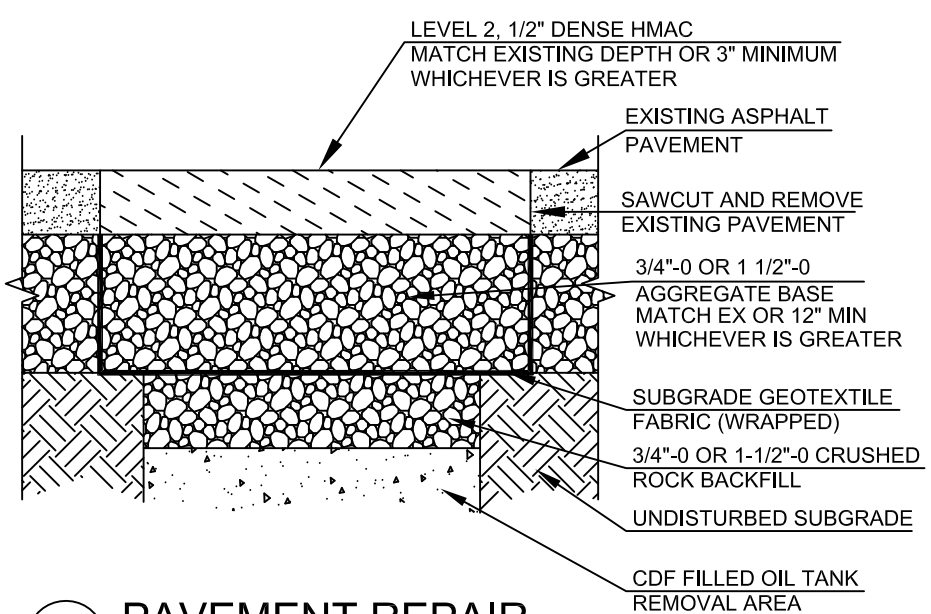

2 PAVEMENT REPAIR
NO SCALE

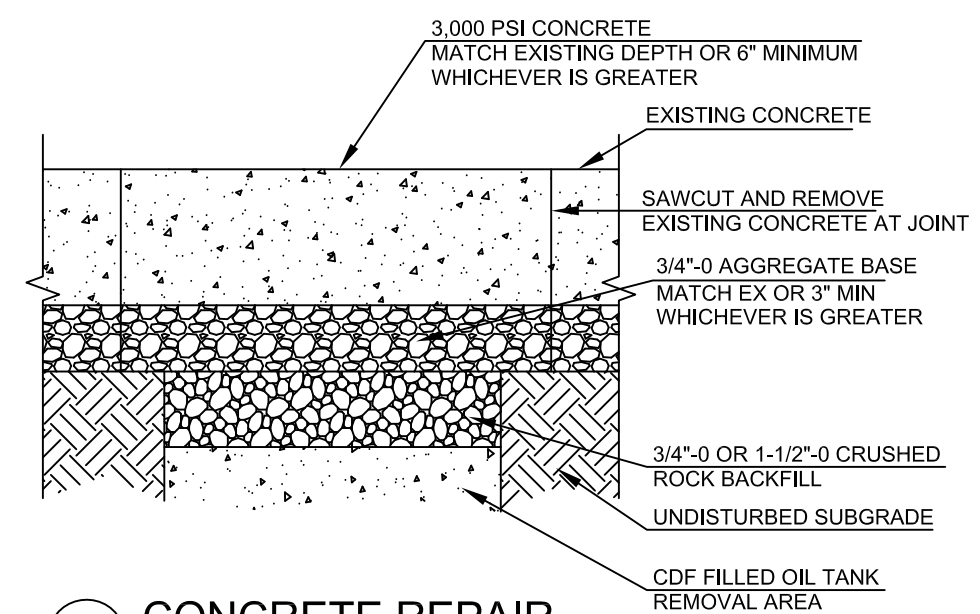

3 CONCRETE REPAIR
NO SCALE

CIVIL LEGEND						
SYMBOL	ABBR.	DESCRIPTION	ABBR.	DESCRIPTION	ABBR.	DESCRIPTION
---SD---	SD	EX STORM DRAIN	4J	EUGENE SCHOOL DISTRICT 4J	GAL	GALLONS
---SS---	SS	EX SANITARY SEWER	AC	ASPHALT CONCRETE	LF	LINEAR FEET
---W---	W	EX WATER	APPROX	APPROXIMATE	MAX	MAXIMUM
---G---	G	EX NATURAL GAS OR PROPANE	BLDG	BUILDING	ME	MATCH EXISTING
-UG ELEG--		EX UNDERGROUND ELECTRIC	CONST	CONSTRUCT	MIN	MINIMUM
---E---		EX UNDERGROUND ELECTRIC	CDF	CONTROLLED DENSITY FILL	NWN	NORTHWEST NATURAL
-TELECOM--		EX TELECOMMUNICATIONS	CFS	CUBIC FEET PER SECOND	NIC	NOT IN CONTRACT
--CCTV---		EX CLOSED CIRCUIT TV	CL	CENTERLINE	OC	ON CENTER
--IRR---		EX IRRIGATION	CY	CUBIC YARDS	PCC	PORTLAND CEMENT CONCRETE
			DESC	DESCRIPTION	PSI	POUNDS PER SQUARE INCH
			DIA	DIAMETER	PT	POINT
			DIST	DISTANCE	SF	SQUARE FOOT
			ELEV	ELEVATION	TC	TOP OF CURB
			EQ	EQUAL	TG	TOP OF GRAVEL
			EX	EXISTING	TP	TOP OF PAVEMENT
			EWB	EUGENE WATER AND ELECTRIC BOARD	TW	TOP OF WALK
			FFE	FINISHED FLOOR ELEVATION	TYP	TYPICAL
			FG	FINISHED GRADE		
			FS	FINISHED SURFACE		
			FT	FOOT		
☒	CB	CATCH BASIN				
CO	CO	CLEANOUT				
⊙	MH	MANHOLE				
X		CONSTRUCTION NOTE				
⊕		SECTION REFERENCE				
1 C1.0		DETAIL REFERENCE				
10% MAX		SLOPE ARROW				

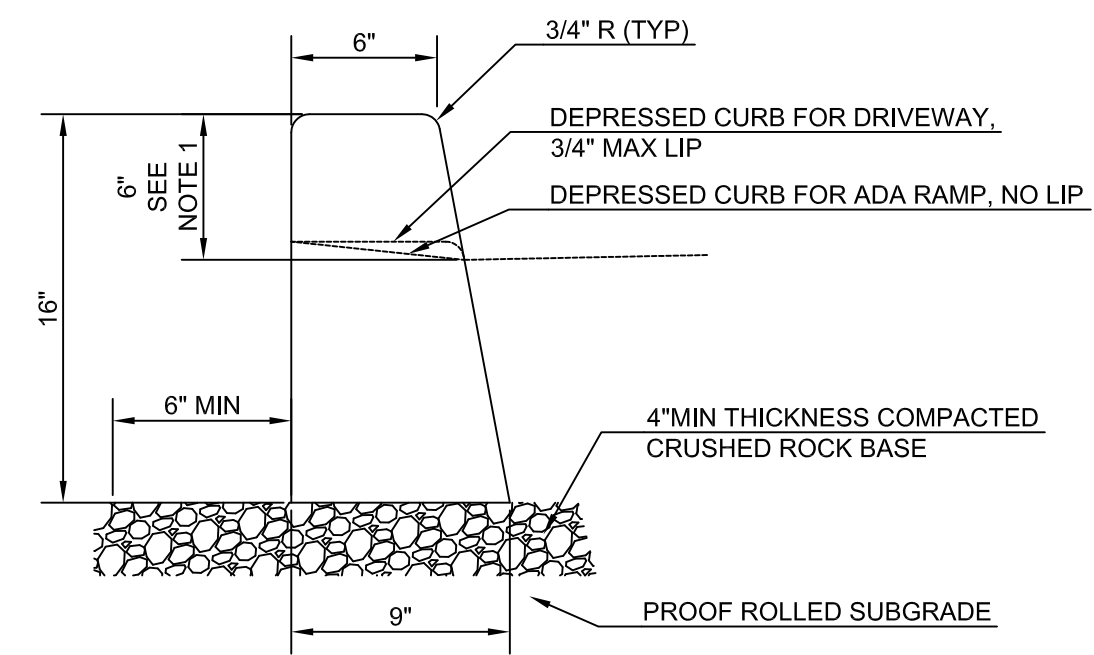

NOTES:
 1. 6" EXPOSURE UNLESS SHOWN OTHERWISE ON GRADING PLAN.
 2. CURB SHALL HAVE 8" DEEP CONTROL JOINTS AT MAX 15' SPACING.
 3. EXTEND CRUSHED ROCK BASE 6" MIN BEYOND BACK OF CURB.

4 FULL DEPTH CURB
NO SCALE

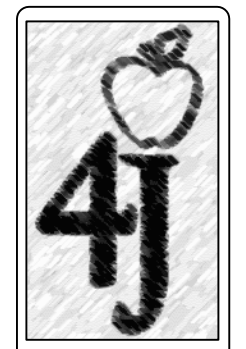

Facilities Management
 School District 4J
 715 W. 4th Avenue
 Eugene, OR 97402
 (541) 687-3257

MULTISITE DECOMMISSION OIL TANKS 2015

LEGEND & DETAILS

PROJECT NO: 141602
 DRAWN: BJR
 CHECKED: BJR

DATE: 04/07/15

SHEET:



NORTH ELEVATION
NO SCALE



SOUTH ELEVATION
NO SCALE



EX WATER METER, BFP AND SIGNS
NO SCALE

**RC
RE**
Roberts Consulting
& Engineering, Inc.
3220 Tilden St. Eugene, Or 97404
Office: 541-689-9197
Fax: 541-463-5443
hr@rcrc.com

REGISTERED PROFESSIONAL
ENGINEER
58901PE
Barbara J. Roberts
OREGON
JANUARY 14, 2003
BARBARA J. ROBERTS
EXPIRATION DATE: 12/31/2016

Facilities
Management
School District 4J
715 W. 4th Avenue
Eugene, OR 97402
(541) 687-3257

MULTISITE
DECOMMISSION OIL
TANKS 2015

ADAMS ELEMENTARY
SCHOOL
950 WEST 22ND AVE
EUGENE, OR 97405

PROJECT NO: 141602
DRAWN: BJR
CHECKED: BJR

DATE: 04/07/15
SITE PLAN
SHEET:
2.0 OF 17

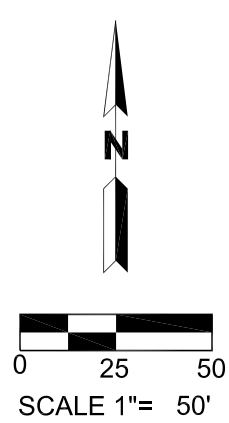

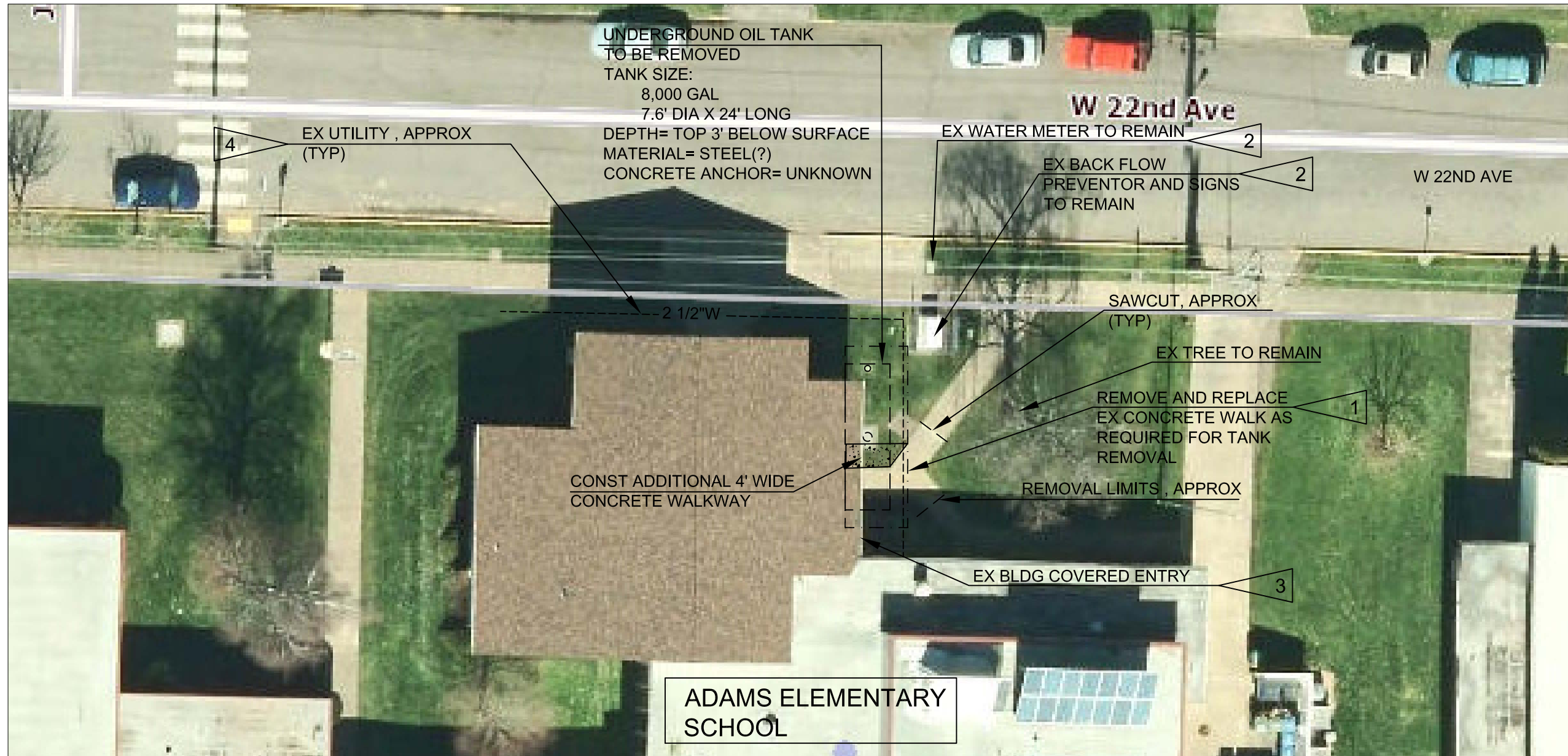

**RC
RE**
 Roberts Consulting & Engineering, Inc.
 3220 Tilden St. Eugene, Or 97404
 Office: 541-689-9197
 Fax: 541-463-5493
 bj@rcene.com

REGISTERED PROFESSIONAL ENGINEER
 58901PE
Barbara J. Roberts
 OREGON
 JANUARY 14, 2003
 BARBARA J. ROBERTS
 EXPIRATION DATE: 12/31/2016

4J
 Facilities Management
 School District 4J
 715 W. 4th Avenue
 Eugene, OR 97402
 (541) 687-3257

SHEET NOTES:

1. OIL TANK LOCATIONS AND DIMENSIONS ARE APPROXIMATE. ACTUAL LIMITS TO BE LOCATED IN THE FIELD BY THE ENGINEER.
2. BOILER HAS ALREADY BEEN DISCONNECTED AND PIPES CAPPED.
3. REMOVE TANK, PIPES AND CATHODIC PROTECTION TO BLDG. BACKFILL AREA WITH CDF TO 24" BELOW FINISH GRADE. REPAIR/FILL HOLES IN WALL FROM PIPE REMOVAL WITH GROUT TO SEAL.
4. BACKFILL AREA WITH CDF TO 24" BELOW FINISH GRADE. REPLACE CONCRETE WALK PER DETAIL3/1.2. PLACE 24" TOPSOIL IN LANDSCAPE AREAS AND SEED DISTURBED LAWN AREAS.

5. CONTRACTOR TO SHORE FOR EXCAVATION IF TANK DECOMMISSIONING REQUIRES EXCAVATION UNDER ADJACENT BUILDING FOUNDATION OR BFP ASSEMBLY.
6. UTILITY SERVICES TO BLDG SHALL NOT BE DISRUPTED UNLESS APPROVED BY 4J.

CONSTRUCTION NOTES:

1. REMOVE EX CONCRETE WALK IN FULL PANEL WIDTHS.
2. PROTECT WATER METER, BACK FLOW PREVENTOR AND SIGNS. REPLACE ANY COMPONENTS DAMAGED DURING EXCAVATION. LOCATION OF UNDERGROUND ELECTRICAL TO LIGHTS ADJACENT SIGN UNKNOWN. CONTRACTOR TO POT HOLE TO LOCATE.
3. SHORE TO PROTECT EX BUILDING COVERED ENTRY FOUNDATION.
4. EX UTILITY LOCATIONS SHOWN ARE APPROXIMATE, BASED ON RECORD DRAWINGS AND UTILITY LOCATES. CONTRACTOR TO POT HOLE AND VERIFY LOCATIONS PRIOR TO TANK REMOVAL WORK. PROTECT EX UTILITIES AND REPLACE ANY COMPONENTS DAMAGED DURING EXCAVATION.

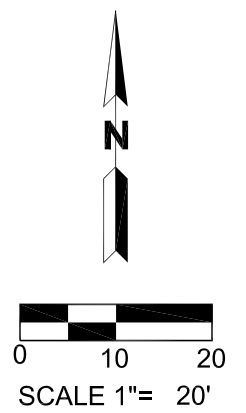

MULTISITE
 DECOMMISSION OIL
 TANKS 2015
 ADAMS ELEMENTARY
 SCHOOL
 950 WEST 22ND AVE
 EUGENE, OR 97405

PROJECT NO: 141602
 DRAWN: BJR
 CHECKED: BJR

DATE: 04/07/15
**TANK
 REMOVAL PLAN**
 SHEET:
2.1 OF 17

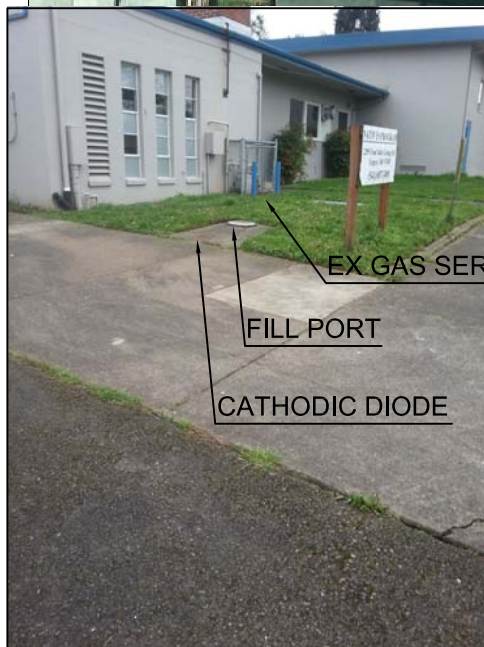

NORTHWEST ELEVATION
NO SCALE



SOUTHWEST ELEVATION
NO SCALE



SOUTH ELEVATION
NO SCALE

**RC
E**

Roberts Consulting
& Engineering, Inc.

3220 Tilden St. Office: 541-689-9197
Eugene, Or 97404 Fax: 541-463-5443
bjr@rcetc.com

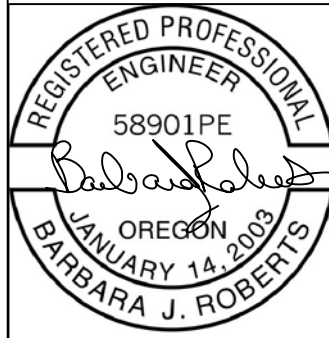

EXPIRATION DATE: 12/31/2016



Facilities
Management
School District 4J
715 W. 4th Avenue
Eugene, OR 97402
(541) 687-3257

MULTISITE
DECOMMISSION OIL
TANKS 2015

BAILEY HILL
INSTRUCTIONAL CENTER
2295 FOUR OAKS
GRANGE ROAD
EUGENE, OR 97405

PROJECT NO: 141602
DRAWN: BJR
CHECKED: BJR

DATE: 04/07/15

SITE PLAN

SHEET:
3.0 OF 17





RC
RE
 Roberts Consulting & Engineering, Inc.
 3220 Tilden St. Eugene, Or 97404
 Office: 541-689-9197
 Fax: 541-463-5443
 hr@rcengine.com

REGISTERED PROFESSIONAL
 ENGINEER
 58901PE
Barbara J. Roberts
 OREGON
 JANUARY 14, 2003
 BARBARA J. ROBERTS

EXPIRATION DATE: 12/31/2016

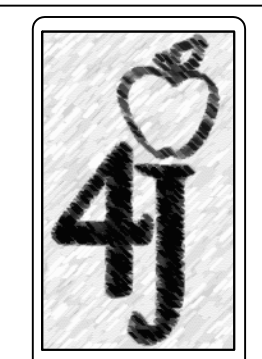

Facilities Management
 School District 4J
 715 W. 4th Avenue
 Eugene, OR 97402
 (541) 687-3257

SHEET NOTES:

1. OIL TANK LOCATIONS AND DIMENSIONS ARE APPROXIMATE. ACTUAL LIMITS TO BE LOCATED IN THE FIELD BY THE ENGINEER.
2. BOILER HAS ALREADY BEEN DISCONNECTED AND PIPES CAPPED.
3. REMOVE TANK, PIPES AND CATHODIC PROTECTION TO BLDG. BACKFILL AREA WITH CDF TO 24" BELOW FINISH GRADE. REPAIR/FILL HOLES IN WALL FROM PIPE REMOVAL WITH GROUT TO SEAL.
4. SAWCUT, REMOVE AND REPAIR PAVEMENT PER DETAILS 1/1.2 AND 2/1.2. REPLACE CONCRETE WALK PER DETAIL 3/1.2. PLACE 24" TOPSOIL IN LANDSCAPE AREAS AND SEED DISTURBED LAWN AREAS.

5. CONTRACTOR TO SHORE FOR EXCAVATION IF TANK REMOVAL REQUIRES EXCAVATION UNDER ADJACENT BUILDING FOUNDATION.
6. UTILITY SERVICES TO BLDG SHALL NOT BE DISRUPTED UNLESS APPROVED BY 4J.

CONSTRUCTION NOTES:

1. REMOVE EX CONCRETE WALK IN FULL PANEL WIDTHS, .
2. REMOVE AND REPLACE EX SIGNS.
3. COORDINATE WITH NW NATURAL TO REMOVE AND REPLACE GAS SERVICE TO ALLOW FOR TANK REMOVAL. 4J WILL SUBMIT REQUEST TO NW NATURAL IN ADVANCE.
4. COORDINATE WITH CENTURY LINK TO REMOVE AND REPLACE SERVICE TO ALLOW FOR TANK REMOVAL..
5. EX UTILITY LOCATIONS SHOWN ARE APPROXIMATE, BASED ON RECORD DRAWINGS AND PUBLIC UTILITY LOCATES. CONTRACTOR TO POT HOLE AND VERIFY LOCATIONS PRIOR TO TANK REMOVAL WORK. PROTECT EX UTILITIES AND REPLACE ANY COMPONENTS DAMAGED DURING EXCAVATION.

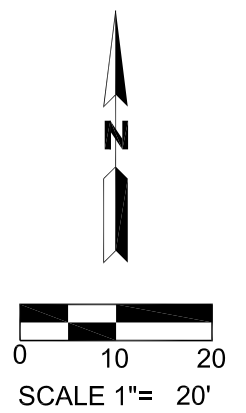

MULTISITE
 DECOMMISSION OIL
 TANKS 2015
 BAILEY HILL
 INSTRUCTIONAL CENTER
 2295 FOUR OAKS
 GRANGE ROAD
 EUGENE, OR 97405

PROJECT NO: 141602
 DRAWN: BJR
 CHECKED: BJR

DATE: 04/07/15
**TANK
 REMOVAL PLAN**
 SHEET:
3.1 OF 17

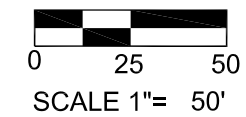
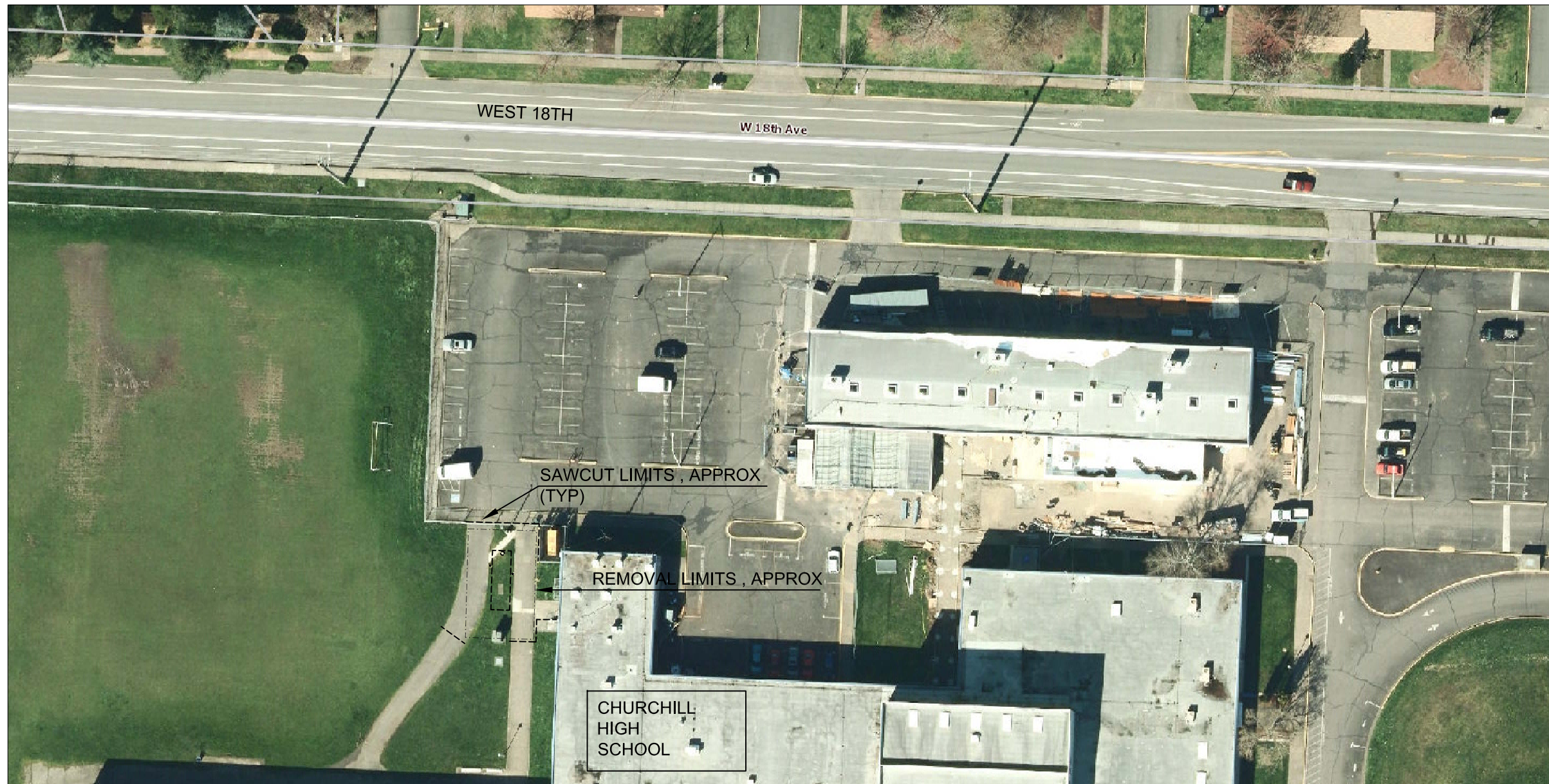

**RC
RE**
 Roberts Consulting
 & Engineering, Inc.
 3220 Tilden St. Eugene, Or 97404
 Office: 541-689-5197
 Fax: 541-463-5443
 hr@rcrc.com

REGISTERED PROFESSIONAL
 ENGINEER
 58901PE
Barbara J. Roberts
 OREGON
 JANUARY 14, 2003
 BARBARA J. ROBERTS
 EXPIRATION DATE: 12/31/2016



Facilities
 Management
 School District 4J
 715 W. 4th Avenue
 Eugene, OR 97402
 (541) 687-3257

MULTISITE
 DECOMMISSION OIL
 TANKS 2015
 CHURCHILL HIGH
 SCHOOL
 1850 BAILEY HILL ROAD
 EUGENE, OR 97405

PROJECT NO: 141602
 DRAWN: BJR
 CHECKED: BJR

DATE: 04/07/15
SITE PLAN
 SHEET:
4.0 OF 17



ELECTRICAL
 TRANSFORMER
 FILL ACCESS

NORTH ELEVATION
 NO SCALE



EX LIGHT POST
 GAS METER CHAIN
 LINK CAGE TO BE
 REPLACED

WEST ELEVATION
 NO SCALE



CATHODIC DIODE



CHAIN LINK FENCE
 AND GATE TO BE
 REPLACED BY
 OTHERS (NIC)
 ACCESS HATCH

SOUTH ELEVATION
 NO SCALE

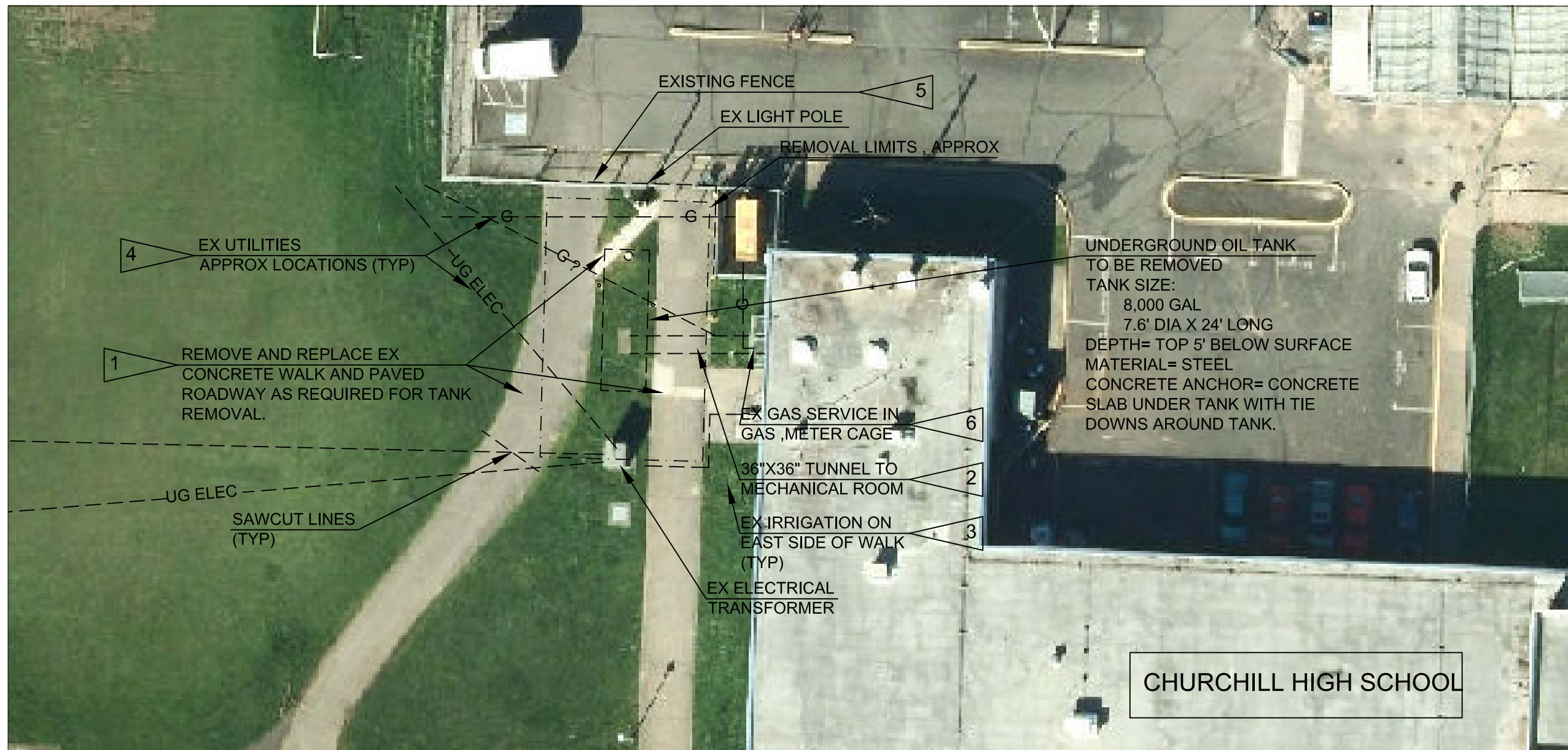

SHEET NOTES:

1. OIL TANK LOCATIONS AND DIMENSIONS ARE APPROXIMATE. ACTUAL LIMITS TO BE LOCATED IN THE FIELD BY THE ENGINEER.
2. BOILER HAS ALREADY BEEN DISCONNECTED AND PIPES CAPPED.
3. REMOVE TANK, PIPES AND CATHODIC PROTECTION TO BLDG. BACKFILL AREA WITH CDF TO 24" BELOW FINISH GRADE. REPAIR/FILL HOLES IN WALL FROM PIPE REMOVAL WITH GROUT TO SEAL.
4. SAWCUT, REMOVE AND REPAIR PAVEMENT PER DETAILS 1/1.2 AND 2/1.2. REPLACE CONCRETE WALK PER DETAIL 3/1.2. PLACE 24" TOPSOIL IN LANDSCAPE AREAS AND SEED DISTURBED LAWN AREAS.
5. CONTRACTOR TO SHORE FOR EXCAVATION IF TANK REMOVAL REQUIRES EXCAVATION UNDER ADJACENT BUILDING FOUNDATION.

6. UTILITY SERVICES TO BLDG SHALL NOT BE DISRUPTED UNLESS APPROVED BY 4J. IT IS ANTICIPATED GAS SERVICE WILL BE DISRUPTED AND CONTRACTOR TO COORDINATE WITH 4J.

CONSTRUCTION NOTES:

1. REMOVE EX CONCRETE WALK IN FULL PANEL WIDTHS. SAWCUT ASPHALT PERPENDICULAR TO ROADWAY.
2. TANK IS UNDER TUNNEL. REMOVE FUEL OIL PIPING TO BLDG AND CAP ENDS. REMOVE TWO COPPER PIPES AND CATHODIC PROTECTION PIPES FROM INSIDE TUNNEL. REMOVE EX TUNNEL TO BLDG FOUNDATION WALL AND BACKFILL WITH CDF.

AFTER REMOVING TUNNEL INSTALL BRICK OR FORM AND POUR CONCRETE TO REPAIR/SEAL FOUNDATION WALL.
3. PROTECT EX IRRIGATION. REPAIR ANY PORTIONS OF SYSTEM DAMAGED IN TANK REMOVAL.

4. APPROXIMATE LOCATIONS, BASED ON RECORD DRAWINGS AND PUBLIC UTILITY LOCATES. CONTRACTOR TO POT HOLE AND VERIFY LOCATIONS PRIOR TO TANK REMOVAL WORK. PROTECT EX UTILITIES AND REPLACE ANY COMPONENTS DAMAGED DURING EXCAVATION. NOTIFY AND COORDINATE WITH UTILITY COMPANIES FOR ANY REQUIRED REPAIR/REPLACEMENT OF UTILITY SERVICES.

5. EX CHAIN LINK FENCE TO BE REPLACED BY OTHERS (NIC). SAWCUT AND REMOVE EX CONCRETE WALK TO EDGE OF PARKING LOT.

6. COORDINATE WITH NW NATURAL TO REMOVE AND REPLACE GAS SERVICE PIPING AND METER ABOVE TUNNEL AND TANK REMOVAL AREA. REMOVE EX GAS METER CAGE AND DISPOSE OF OFF-SITE. INSTALL NEW CHAIN LINK GAS METER CAGE PER SPECIFICATION AND TO MATCH EXISTING CAGE DIMENSIONS. COLOR TO BE BLACK VINYL WITH INFILL TO MATCH. CONNECT CAGE TO NORTH FENCING.

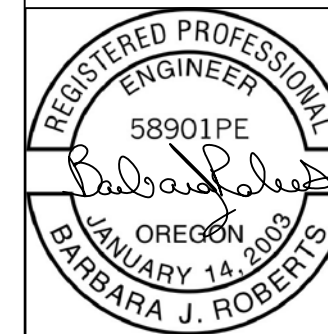
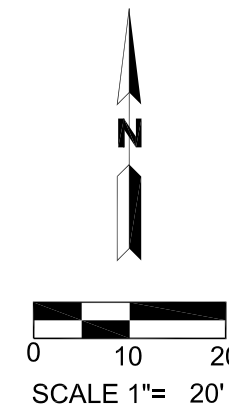

EXPIRATION DATE: 12/31/2016



Facilities
Management
School District 4J
715 W. 4th Avenue
Eugene, OR 97402
(541) 687-3257

MULTISITE
DECOMMISSION OIL
TANKS 2015

CHURCHILL HIGH
SCHOOL
1850 BAILEY HILL ROAD
EUGENE, OR 97405

PROJECT NO: 141602
DRAWN: BJR
CHECKED: BJR

DATE: 04/07/15

**TANK
REMOVAL PLAN**
SHEET:

4.1 OF 17