

AP[®] Physics B

Practice Exam

The questions contained in this AP[®] Physics B Practice Exam are written to the content specifications of AP Exams for this subject. Taking this practice exam should provide students with an idea of their general areas of strengths and weaknesses in preparing for the actual AP Exam. Because this AP Physics B Practice Exam has never been administered as an operational AP Exam, statistical data are not available for calculating potential raw scores or conversions into AP grades.

This AP Physics B Practice Exam is provided by the College Board for AP Exam preparation. Teachers are permitted to download the materials and make copies to use with their students in a classroom setting only. To maintain the security of this exam, teachers should collect all materials after their administration and keep them in a secure location. Teachers may not redistribute the files electronically for any reason.

Contents

Directions for Administration	ii
Section I: Multiple-Choice Questions	1
Section II: Free-Response Questions	18
Student Answer Sheet for Multiple-Choice Section	28
Multiple-Choice Answer Key	29
Free-Response Scoring Guidelines.....	30

The College Board: Connecting Students to College Success

The College Board is a not-for-profit membership association whose mission is to connect students to college success and opportunity. Founded in 1900, the association is composed of more than 5,000 schools, colleges, universities, and other educational organizations. Each year, the College Board serves seven million students and their parents, 23,000 high schools, and 3,500 colleges through major programs and services in college admissions, guidance, assessment, financial aid, enrollment, and teaching and learning. Among its best-known programs are the SAT[®], the PSAT/NMSQT[®], and the Advanced Placement Program[®] (AP[®]). The College Board is committed to the principles of excellence and equity, and that commitment is embodied in all of its programs, services, activities, and concerns.

Visit the College Board on the Web: www.collegeboard.com.

AP Central is the official online home for the AP Program: apcentral.collegeboard.com.

AP[®] Physics B

Directions for Administration

The AP Physics B Exam is three hours in length and consists of a multiple-choice section and a free-response section.

- The 90-minute multiple-choice section contains 70 questions and accounts for 50 percent of the final grade.
- The 90-minute free-response section usually contains 6 or 7 questions and accounts for 50 percent of the final grade. This practice exam contains 7 questions.

A 10-minute break should be provided after Section I is completed.

The actual AP Exam is administered in one session. Students will have the most realistic experience if a complete morning or afternoon is available to administer this practice exam. If a schedule does not permit one time period for the entire practice exam administration, it would be acceptable to administer Section I one day and Section II on a subsequent day.

Total scores on the multiple-choice section are based only on the number of questions answered correctly. No points are deducted for incorrect answers and no points are awarded for unanswered questions.

- The use of calculators is permitted only on Section II. Straightedges or rulers are allowed on both parts of the exam.
- It is suggested that the practice exam be completed using a pencil to simulate an actual administration.
- Teachers will need to provide paper for the students to write their free-response answers. Teachers should provide directions to the students indicating how they wish the responses to be labeled so the teacher will be able to associate the student's response with the question the student intended to answer.
- The 2008–2009 AP Physics B table of information is included as a part of Section I. The table and the AP Physics B equation lists are included with Section II. The equation lists are not allowed for Section I. If you use these exams in subsequent years you should download the newer versions of the table and lists from AP Central.
- Remember that students are not allowed to remove any materials, including scratch work, from the testing site.

Section I
Multiple-Choice Questions

TABLE OF INFORMATION FOR 2008 and 2009

CONSTANTS AND CONVERSION FACTORS	
Proton mass, $m_p = 1.67 \times 10^{-27}$ kg	Electron charge magnitude, $e = 1.60 \times 10^{-19}$ C
Neutron mass, $m_n = 1.67 \times 10^{-27}$ kg	1 electron volt, $1 \text{ eV} = 1.60 \times 10^{-19}$ J
Electron mass, $m_e = 9.11 \times 10^{-31}$ kg	Speed of light, $c = 3.00 \times 10^8$ m/s
Avogadro's number, $N_0 = 6.02 \times 10^{23}$ mol ⁻¹	Universal gravitational constant, $G = 6.67 \times 10^{-11}$ m ³ /kg·s ²
Universal gas constant, $R = 8.31$ J/(mol·K)	Acceleration due to gravity at Earth's surface, $g = 9.8$ m/s ²
Boltzmann's constant, $k_B = 1.38 \times 10^{-23}$ J/K	
1 unified atomic mass unit,	$1 \text{ u} = 1.66 \times 10^{-27}$ kg = 931 MeV/c ²
Planck's constant,	$h = 6.63 \times 10^{-34}$ J·s = 4.14×10^{-15} eV·s
	$hc = 1.99 \times 10^{-25}$ J·m = 1.24×10^3 eV·nm
Vacuum permittivity,	$\epsilon_0 = 8.85 \times 10^{-12}$ C ² /N·m ²
Coulomb's law constant, $k = 1/4\pi\epsilon_0 = 9.0 \times 10^9$ N·m ² /C ²	
Vacuum permeability,	$\mu_0 = 4\pi \times 10^{-7}$ (T·m)/A
Magnetic constant, $k' = \mu_0/4\pi = 10^{-7}$ (T·m)/A	
1 atmosphere pressure,	$1 \text{ atm} = 1.0 \times 10^5$ N/m ² = 1.0×10^5 Pa

UNIT SYMBOLS	meter,	m	mole,	mol	watt,	W	farad,	F
	kilogram,	kg	hertz,	Hz	coulomb,	C	tesla,	T
	second,	s	newton,	N	volt,	V	degree Celsius,	°C
	ampere,	A	pascal,	Pa	ohm,	Ω	electron-volt,	eV
	kelvin,	K	joule,	J	henry,	H		

PREFIXES		
Factor	Prefix	Symbol
10 ⁹	giga	G
10 ⁶	mega	M
10 ³	kilo	k
10 ⁻²	centi	c
10 ⁻³	milli	m
10 ⁻⁶	micro	μ
10 ⁻⁹	nano	n
10 ⁻¹²	pico	p

VALUES OF TRIGONOMETRIC FUNCTIONS FOR COMMON ANGLES							
θ	0°	30°	37°	45°	53°	60°	90°
$\sin \theta$	0	1/2	3/5	$\sqrt{2}/2$	4/5	$\sqrt{3}/2$	1
$\cos \theta$	1	$\sqrt{3}/2$	4/5	$\sqrt{2}/2$	3/5	1/2	0
$\tan \theta$	0	$\sqrt{3}/3$	3/4	1	4/3	$\sqrt{3}$	∞

The following conventions are used in this exam.

- I. Unless otherwise stated, the frame of reference of any problem is assumed to be inertial.
- II. The direction of any electric current is the direction of flow of positive charge (conventional current).
- III. For any isolated electric charge, the electric potential is defined as zero at an infinite distance from the charge.
- IV. For mechanics and thermodynamics equations, W represents the work done on a system.

PHYSICS B
SECTION I
Time—90 minutes
70 Questions

Directions: Each of the questions or incomplete statements below is followed by five suggested answers or completions. Select the one that is best in each case and place the letter of your choice in the corresponding box on the student answer sheet.

Note: To simplify calculations, you may use $g = 10 \text{ m/s}^2$ in all problems.

Questions 1-4

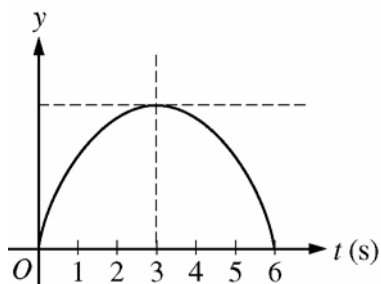

A ball is thrown straight up by a student at rest on the surface of Earth. A graph of the position y as a function of time t , in seconds, is shown above. Air resistance is negligible.

- At which of the following times is the ball farthest from the student?
(A) 1 s
(B) 2 s
(C) 3 s
(D) 4 s
(E) 5 s
- At which of the following times is the speed of the ball the least?
(A) 1 s
(B) 2 s
(C) 3 s
(D) 4 s
(E) 5 s

- Which of the following best describes the acceleration of the ball?
(A) It is downward and constant from 0 to 6 s.
(B) It is downward and increases in magnitude from 0 to 3 s, then decreases.
(C) It is downward and decreases in magnitude from 0 to 3 s, then increases.
(D) It is upward and increases in magnitude from 0 to 3 s, then decreases.
(E) It is upward and decreases in magnitude from 0 to 3 s, then increases.
 - What is the initial speed of the ball?
(A) 30 m/s
(B) 45 m/s
(C) 60 m/s
(D) 90 m/s
(E) 180 m/s
-
- Two boxes of different masses in an orbiting space station appear to float at rest—one above the other—with respect to the station. An astronaut applies the same force to both boxes. Can the boxes have the same acceleration with respect to the space station?
(A) No, because the boxes are moving in orbits of different radius.
(B) No, because the box of greater mass requires more force to reach the same acceleration.
(C) Yes, because both boxes appear weightless.
(D) Yes, because both boxes are accelerating toward Earth at the same rate.
(E) It cannot be determined without knowing whether the boxes are being pushed parallel or perpendicular to Earth's gravity.

GO ON TO THE NEXT PAGE.

6. An object is dropped from rest from a certain height. Air resistance is negligible. After falling a distance d , the object's kinetic energy is proportional to which of the following?

- (A) $1/d^2$
- (B) $1/d$
- (C) \sqrt{d}
- (D) d
- (E) d^2

7. An object is projected vertically upward from ground level. It rises to a maximum height H . If air resistance is negligible, which of the following must be true for the object when it is at a height $H/2$?

- (A) Its speed is half of its initial speed.
- (B) Its kinetic energy is half of its initial kinetic energy.
- (C) Its potential energy is half of its initial potential energy.
- (D) Its total mechanical energy is half of its initial value.
- (E) Its total mechanical energy is half of its value at the highest point.

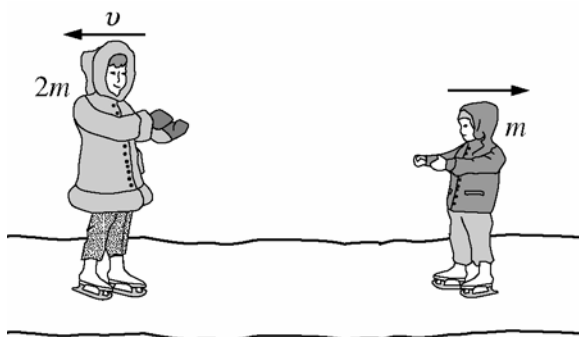

8. A boy of mass m and a girl of mass $2m$ are initially at rest at the center of a frozen pond. They push each other so that she slides to the left at speed v across the frictionless ice surface and he slides to the right as shown above. What is the total work done by the children?

- (A) Zero
- (B) mv
- (C) mv^2
- (D) $2mv^2$
- (E) $3mv^2$

9. An object of mass M travels along a horizontal air track at a constant speed v and collides elastically with an object of identical mass that is initially at rest on the track. Which of the following statements is true for the two objects after the impact?

- (A) The total momentum is Mv and the total kinetic energy is $\frac{1}{2}Mv^2$.
- (B) The total momentum is Mv and the total kinetic energy is less than $\frac{1}{2}Mv^2$.
- (C) The total momentum is less than Mv and the total kinetic energy is $\frac{1}{2}Mv^2$.
- (D) The momentum of each object is $\frac{1}{2}Mv$.
- (E) The kinetic energy of each object is $\frac{1}{4}Mv^2$.

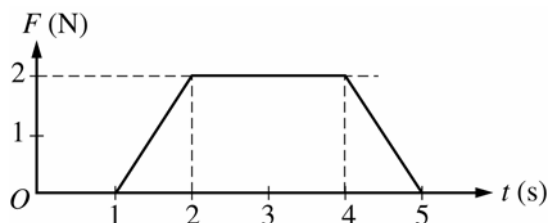

10. A 2 kg object initially moving with a constant velocity is subjected to a force of magnitude F in the direction of motion. A graph of F as a function of time t is shown above. What is the increase, if any, in the velocity of the object during the time the force is applied?

- (A) 0 m/s
- (B) 2.0 m/s
- (C) 3.0 m/s
- (D) 4.0 m/s
- (E) 6.0 m/s

GO ON TO THE NEXT PAGE.

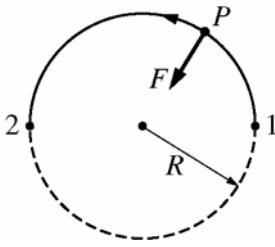

11. A particle P moves around the circle of radius R shown above under the influence of a radial force of magnitude F . What is the work done by the radial force as the particle moves from position 1 to position 2 halfway around the circle?
- (A) Zero
 (B) RF
 (C) $2RF$
 (D) πRF
 (E) $2\pi RF$
12. An object of mass m hanging from a spring of spring constant k oscillates with a certain frequency. What is the length of a simple pendulum that has the same frequency of oscillation?
- (A) $\frac{mk}{g}$
 (B) $\frac{mg}{k}$
 (C) $\frac{kg}{m}$
 (D) $\frac{k}{mg}$
 (E) $\frac{g}{mk}$
13. A spherical planet has mass greater than that of Earth, but its density is unknown. The weight of an object on that planet compared with its weight on Earth is which of the following?
- (A) Larger
 (B) The same
 (C) Smaller
 (D) It cannot be determined without information about the planet's size.
 (E) It cannot be determined without information about the planet's atmosphere.

Questions 14-15

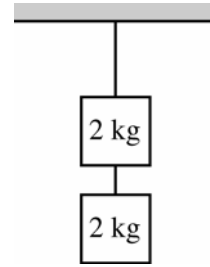

Two blocks of wood, each of mass 2 kg, are suspended from the ceiling by strings of negligible mass, as shown above.

14. What is the tension in the upper string?
- (A) 10 N
 (B) 20 N
 (C) 40 N
 (D) 50 N
 (E) 60 N
15. What is the force exerted on the upper block by the lower string?
- (A) Zero
 (B) 10 N upward
 (C) 10 N downward
 (D) 20 N upward
 (E) 20 N downward
-
16. A vertical force of 30 N is applied uniformly to a flat button with a radius of 1 cm that is lying on a table. Which of the following is the best order of magnitude estimate for the pressure applied to the button?
- (A) 10 Pa
 (B) 10^2 Pa
 (C) 10^3 Pa
 (D) 10^4 Pa
 (E) 10^5 Pa

GO ON TO THE NEXT PAGE.

17. A ball that can float on water has mass 5.00 kg and volume $2.50 \times 10^{-2} \text{ m}^3$. What is the magnitude of the downward force that must be applied to the ball to hold it motionless and completely submerged in freshwater of density $1.00 \times 10^3 \text{ kg/m}^3$?

- (A) 20.0 N
- (B) 25.0 N
- (C) 30.0 N
- (D) 200 N
- (E) 250 N

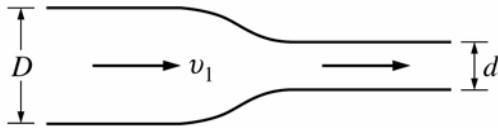

18. Water flows through the pipe shown above. At the larger end, the pipe has diameter D and the speed of the water is v_1 . What is the speed of the water at the smaller end, where the pipe has diameter d ?

- (A) v_1
- (B) $\left(\frac{d}{D}\right)v_1$
- (C) $\left(\frac{D}{d}\right)v_1$
- (D) $\left(\frac{d^2}{D^2}\right)v_1$
- (E) $\left(\frac{D^2}{d^2}\right)v_1$

19. The floor of a building is made from a square, solid piece of concrete. When the temperature of the floor increases from 20°C to 28°C , each side of the square expands by 0.4 cm. If the temperature of the floor were to decrease from 20°C to 8°C , by how much would each side of the square contract?

- (A) 0.2 cm
- (B) 0.4 cm
- (C) 0.6 cm
- (D) 1.0 cm
- (E) It cannot be determined without knowing the coefficient of linear expansion of the concrete.

20. The temperature of an ideal gas is directly proportional to which of the following?

- (A) Average translational kinetic energy of the molecules
- (B) Average velocity of the molecules
- (C) Average potential energy of the molecules
- (D) Average momentum of the molecules
- (E) None of the above

21. A heat engine operates in a cycle between temperatures 700 K and 400 K. The heat input to the engine during each cycle is 2800 J. What is the maximum possible work done by the engine in each cycle?

- (A) 1200 J
- (B) 1600 J
- (C) 2100 J
- (D) 2800 J
- (E) 4400 J

GO ON TO THE NEXT PAGE.

Questions 22-23

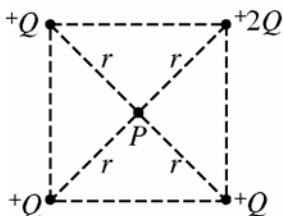

Four positive charges are fixed at the corners of a square, as shown above. Three of the charges have magnitude Q , and the fourth charge has a magnitude $2Q$. Point P is at the center of the square at a distance r from each charge.

22. What is the electric potential at point P ?

- (A) Zero
- (B) $\frac{kQ}{r}$
- (C) $\frac{2kQ}{r}$
- (D) $\frac{4kQ}{r}$
- (E) $\frac{5kQ}{r}$

23. What is the magnitude of the electric field at point P ?

- (A) Zero
- (B) $\frac{kQ}{r^2}$
- (C) $\frac{2kQ}{r^2}$
- (D) $\frac{4kQ}{r^2}$
- (E) $\frac{5kQ}{r^2}$

24. Conducting sphere X is initially uncharged. Conducting sphere Y has twice the diameter of sphere X and initially has charge q . If the spheres are connected by a long thin wire, which of the following is true once equilibrium has been reached?

- (A) Sphere Y has half the potential of sphere X .
- (B) Spheres X and Y have the same potential.
- (C) Sphere Y has twice the potential of sphere X .
- (D) Sphere Y has half the charge of sphere X .
- (E) Spheres X and Y have the same charge.

25. If the separation between the plates of an isolated charged parallel-plate capacitor is increased slightly, which of the following also increases?

- (A) The capacitance
- (B) The stored electrostatic energy
- (C) The force of attraction between the plates
- (D) The magnitude of the charge on each plate
- (E) The magnitude of the electric field in the region between the plates

Questions 26-28

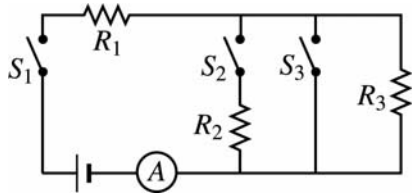

In the circuit above, the resistors all have the same resistance. The battery, wires, and ammeter have negligible resistance. A closed switch also has negligible resistance.

26. Closing which of the switches will produce the greatest power dissipation in R_2 ?

- (A) S_1 only
- (B) S_2 only
- (C) S_1 and S_2 only
- (D) S_1 and S_3 only
- (E) S_1 , S_2 , and S_3

27. Closing which of the switches will produce the greatest reading on the ammeter?

- (A) S_1 only
- (B) S_2 only
- (C) S_3 only
- (D) S_1 and S_2
- (E) S_1 and S_3

28. Closing which of the switches will produce the greatest voltage across R_3 ?

- (A) S_1 only
- (B) S_2 only
- (C) S_1 and S_2 only
- (D) S_1 and S_3 only
- (E) S_1 , S_2 , and S_3

29. Two cables can be used to wire a circuit. Cable A has a lower resistivity, a larger diameter, and a different length than cable B. Which cable should be used to minimize heat loss if the same current is maintained in either cable?

- (A) Cable A
- (B) Cable B
- (C) The heat loss is the same for both.
- (D) It cannot be determined without knowing the length of each cable.
- (E) It cannot be determined without knowing the materials contained in each cable.

Questions 30-31

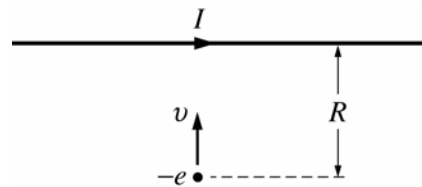

An electron of charge $-e$ and a long straight wire carrying a current I to the right are both in the plane of the page, as shown above. In the position shown, the electron is a distance R from the wire and is moving directly toward it with speed v .

30. What is the direction of the magnetic force on the electron when it is in this position?

- (A) Toward the bottom of the page
- (B) Into the plane of the page
- (C) Out of the plane of the page
- (D) To the left
- (E) To the right

31. What is the magnitude of the magnetic force on the electron when it is in this position?

- (A) $\frac{\mu_0}{2\pi} \frac{Iev}{R}$
- (B) $\frac{\mu_0}{2\pi} \frac{I^2ev}{R}$
- (C) $\frac{\mu_0}{2\pi} \frac{Ie^2v}{R}$
- (D) $\frac{\mu_0}{2\pi} \frac{Iev^2}{R}$
- (E) $\frac{\mu_0}{2\pi} \frac{Iev}{R^2}$

GO ON TO THE NEXT PAGE.

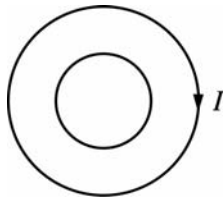

32. Two concentric, circular wire loops lie in the same plane, as shown above. The current I in the outer loop is clockwise and increasing with time. The induced current in the inner loop is
- (A) zero
 (B) clockwise
 (C) counterclockwise
 (D) alternating between clockwise and counterclockwise
 (E) either clockwise or counterclockwise, depending on the ratio of the radii of the loops

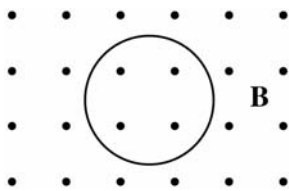

33. A uniform magnetic field \mathbf{B} is directed out of the page, as shown above. A loop of wire of area 0.40 m^2 is in the plane of the page. At a certain instant the field has a magnitude of 3.0 T and is decreasing at the rate of 0.50 T/s . The magnitude of the induced emf in the wire loop at this instant is most nearly
- (A) 0.20 V
 (B) 0.60 V
 (C) 1.2 V
 (D) 1.5 V
 (E) 2.8 V

Questions 34-35

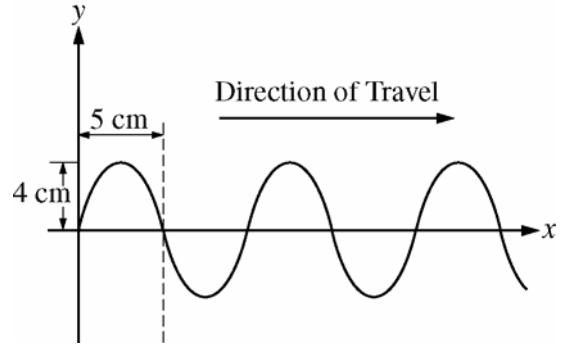

The figure above shows a transverse wave traveling to the right at a particular instant of time. The period of the wave is 0.2 s .

34. What is the amplitude of the wave?
- (A) 4 cm
 (B) 5 cm
 (C) 8 cm
 (D) 10 cm
 (E) 16 cm
35. What is the speed of the wave?
- (A) 4 cm/s
 (B) 25 cm/s
 (C) 50 cm/s
 (D) 100 cm/s
 (E) 200 cm/s

36. Which of the following statements are true for both sound waves and electromagnetic waves?
- I. They can undergo refraction.
 II. They can undergo diffraction.
 III. They can produce a two-slit interference pattern.
 IV. They can produce standing waves.
- (A) I and II only
 (B) III and IV only
 (C) I, II, and III only
 (D) II, III, and IV only
 (E) I, II, III, and IV

GO ON TO THE NEXT PAGE.

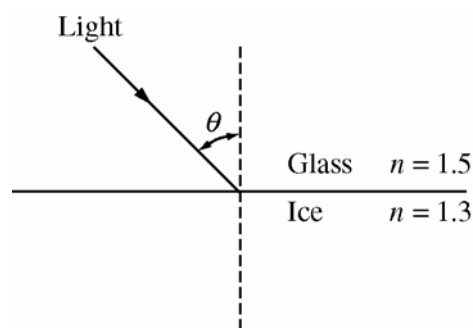
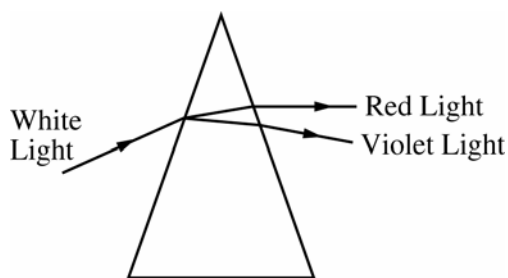

37. As shown above, a beam of white light is separated into separate colors when it passes through a glass prism. Red light is refracted through a smaller angle than violet light because red light has a
- (A) slower speed in glass than violet light
 - (B) faster speed in glass than violet light
 - (C) slower speed in the incident beam than violet light
 - (D) faster speed in the incident beam than violet light
 - (E) greater intensity than violet light
38. If one of the two slits in a Young's double-slit demonstration of the interference of light is covered with a thin filter that transmits only half the light intensity, which of the following occurs?
- (A) The fringe pattern disappears.
 - (B) The bright lines are brighter and the dark lines are darker.
 - (C) The bright lines and the dark lines are all darker.
 - (D) The bright lines and the dark lines are all brighter.
 - (E) The dark lines are brighter and the bright lines are darker.

39. A ray of light in glass that is incident on an interface with ice, as shown above, is partially reflected and partially refracted. The index of refraction n for each of the two media is given in the figure. How do the angle of reflection and the angle of refraction compare with the angle of incidence θ ?

	<u>Angle of Reflection</u>	<u>Angle of Refraction</u>
(A)	Same	Larger
(B)	Same	Smaller
(C)	Smaller	Same
(D)	Smaller	Smaller
(E)	Larger	Larger

GO ON TO THE NEXT PAGE.

Questions 40-41

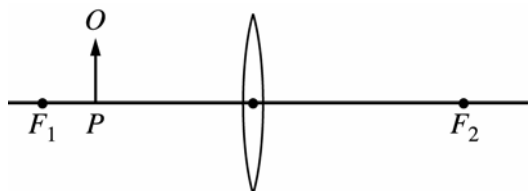

An object O is located at point P to the left of a converging lens, as shown in the figure above. F_1 and F_2 are the focal points of the lens.

40. If the focal length of the lens is 0.40 m and point P is 0.30 m to the left of the lens, where is the image of the object located?
- (A) 1.2 m to the left of the lens
 (B) 0.17 m to the left of the lens
 (C) At the lens
 (D) 0.17 m to the right of the lens
 (E) 1.2 m to the right of the lens
41. Which of the following characterizes the image when the object is in the position shown?
- (A) Real, inverted, and smaller than the object
 (B) Real, upright, and larger than the object
 (C) Real, inverted, and larger than the object
 (D) Virtual, upright, and larger than the object
 (E) Virtual, upright, and smaller than the object
-
42. The work function for a metal is ϕ . What is the threshold frequency of incident light required for the emission of photoelectrons from a cathode made of that metal?
- (A) $\frac{\phi}{h}$
 (B) $\frac{h}{\phi}$
 (C) ϕh
 (D) $\frac{\phi}{hc}$
 (E) $\frac{hc}{\phi}$

43. Two monochromatic light beams, one red and one green, have the same intensity and the same cross-sectional area. How does the energy of each photon and the number of photons crossing a unit area per second in the red beam compare with those of the green beam?

	<u>Energy of Photon</u>	<u>Number of Photons Crossing Unit Area per Second</u>
(A)	Same	Same
(B)	Greater for red	Less for red
(C)	Greater for red	Greater for red
(D)	Less for red	Less for red
(E)	Less for red	Greater for red

44. $^{226}_{88}\text{Ra}$ decays into $^{222}_{86}\text{Rn}$ plus
- (A) a proton
 (B) a neutron
 (C) an electron
 (D) a helium nucleus (^4_2He)
 (E) a deuteron (^2_1H)
45. In any physically correct equation, the units of any two quantities must be the same whenever these quantities are
- (A) added or multiplied only
 (B) subtracted or divided only
 (C) multiplied or divided only
 (D) added or subtracted only
 (E) added, subtracted, multiplied, or divided
46. On a day when the speed of sound is 340 m/s, a ship sounds its whistle. The echo of the sound from the shore is heard at the ship 6.0 s later. How far is the ship from the shore?
- (A) 56.7 m
 (B) 113 m
 (C) 1020 m
 (D) 2040 m
 (E) 4080 m

GO ON TO THE NEXT PAGE.

47. An isolated pair of charged particles X and Y , with masses m_X and $m_Y = 2m_X$, repel one another. The electrostatic force is the only force between them. If particle X accelerates at 2.2 m/s^2 , what is the acceleration of particle Y ?

- (A) 0 m/s^2
- (B) 0.55 m/s^2
- (C) 1.1 m/s^2
- (D) 2.2 m/s^2
- (E) 4.4 m/s^2

48. An object initially at rest is subjected to a constant net force. Measurements are taken of its velocity v at different distances d from the starting position. A graph of which of the following should exhibit a straight-line relationship?

- (A) d^2 versus v^{-2}
- (B) d^2 versus v
- (C) d versus v
- (D) d versus v^{-1}
- (E) d versus v^2

49. A disk slides to the right on a horizontal, frictionless air table and collides with another disk that was initially stationary. The figures below show a top view of the initial path I of the sliding disk and a hypothetical path H for each disk after the collision. Which figure shows an impossible situation?

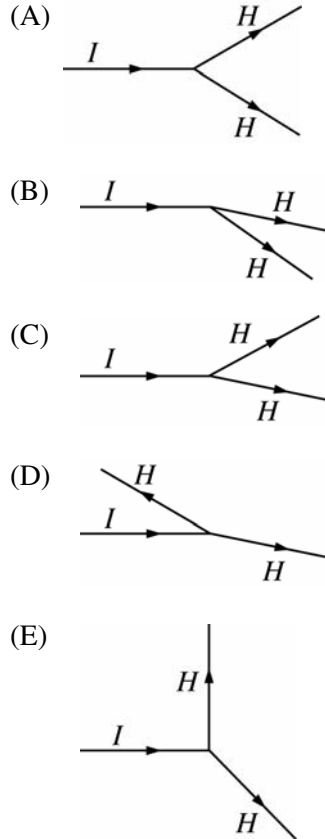

50. A meterstick of negligible mass is placed on a fulcrum at the 0.60 m mark, with a 2.0 kg mass hung at the 0 m mark and a 1.0 kg mass hung at the 1.0 m mark. The meterstick is released from rest in a horizontal position. Immediately after release, the magnitude of the net torque on the meterstick about the fulcrum is most nearly

- (A) $2.0 \text{ N}\cdot\text{m}$
- (B) $8.0 \text{ N}\cdot\text{m}$
- (C) $10 \text{ N}\cdot\text{m}$
- (D) $14 \text{ N}\cdot\text{m}$
- (E) $16 \text{ N}\cdot\text{m}$

GO ON TO THE NEXT PAGE.



51. The two charged metal spheres X and Y shown above are far apart, and each is isolated from all other charges. The radius of sphere X is greater than that of sphere Y , and the magnitudes of the electric fields just outside their surfaces are the same. How does the charge on sphere X compare with that on sphere Y ?

- (A) It is greater.
- (B) It is less.
- (C) It is the same.
- (D) It cannot be determined without knowing the actual radii of the spheres.
- (E) It cannot be determined without knowing the actual value of the electric field just outside the spheres.

Questions 52-53

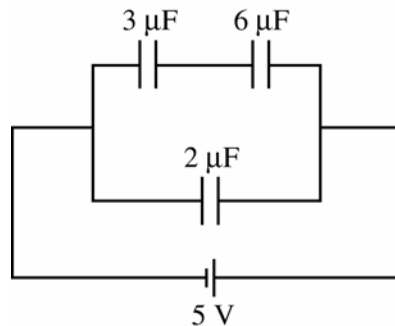

Three capacitors are connected to a 5 V source, as shown in the circuit diagram above.

52. The equivalent capacitance for the circuit is

- (A) $\frac{1}{11} \mu\text{F}$
- (B) $\frac{11}{18} \mu\text{F}$
- (C) $1 \mu\text{F}$
- (D) $4 \mu\text{F}$
- (E) $11 \mu\text{F}$

53. How do the charge Q_3 stored in the $3 \mu\text{F}$ capacitor and the voltage V_3 across it compare with those of the $6 \mu\text{F}$ capacitor?

- | <u>Charge</u> | <u>Voltage</u> |
|-----------------|----------------|
| (A) $Q_3 < Q_6$ | $V_3 = V_6$ |
| (B) $Q_3 = Q_6$ | $V_3 < V_6$ |
| (C) $Q_3 = Q_6$ | $V_3 > V_6$ |
| (D) $Q_3 > Q_6$ | $V_3 = V_6$ |
| (E) $Q_3 > Q_6$ | $V_3 > V_6$ |

GO ON TO THE NEXT PAGE.

54. An ion with a charge $+Q$ moves with constant speed v in a circular path of radius R in a uniform magnetic field of magnitude B . What is the mass of the ion?

- (A) $\frac{2QB}{v}$
- (B) $\frac{QBR}{v}$
- (C) $\frac{2QB}{v^2}$
- (D) $\frac{QBR}{v^2}$
- (E) $\frac{2QBR}{v^2}$

55. A standing wave pattern is created on a guitar string as a person tunes the guitar by changing the tension in the string. Which of the following properties of the waves on the string will change as a result of adjusting only the tension in the string?

- I. Speed of the traveling wave that creates the pattern
 - II. Frequency of the standing wave
 - III. Wavelength of the standing wave
- (A) I only
 - (B) II only
 - (C) I and II only
 - (D) II and III only
 - (E) I, II, and III

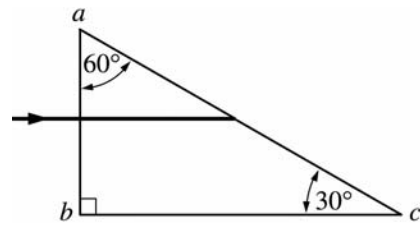

56. A ray of light in air is incident on a 30° - 60° - 90° prism, perpendicular to face ab , as shown in the diagram above. The ray enters the prism and strikes face ac at the critical angle. What is the index of refraction of the prism?

- (A) $\frac{1}{2}$
- (B) $\sqrt{\frac{3}{2}}$
- (C) $\frac{2\sqrt{3}}{3}$
- (D) 2
- (E) 3

57. Correct statements about the binding energy of a nucleus include which of the following?

- I. It is the energy needed to separate the nucleus into its individual protons and neutrons.
 - II. It is the energy liberated when the nucleus is formed from the original nucleons.
 - III. It is the energy equivalent of the apparent loss of mass of its nucleon constituents.
- (A) I only
 - (B) III only
 - (C) I and II only
 - (D) II and III only
 - (E) I, II, and III

58. A car of mass 900 kg is traveling at 20 m/s when the brakes are applied. The car then comes to a complete stop in 5 s. What is the average power that the brakes produce in stopping the car?

- (A) 1800 W
- (B) 3600 W
- (C) 7200 W
- (D) 36,000 W
- (E) 72,000 W

GO ON TO THE NEXT PAGE.

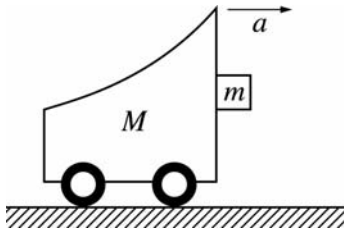

59. The figure above shows a cart of mass M accelerating to the right with a block of mass m held to the front surface only by friction. The coefficient of friction between the surfaces is μ . What is the minimum acceleration a of the cart such that the block will not fall?
- (A) μg
 (B) $\frac{g}{\mu}$
 (C) $\frac{gm}{\mu(M + m)}$
 (D) $\frac{gM}{\mu(M + m)}$
 (E) $\frac{\mu gM}{M + m}$

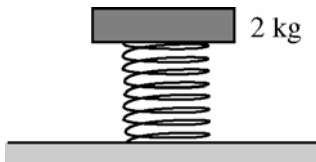

60. A platform of mass 2 kg is supported by a spring of negligible mass as shown above. The platform oscillates with a period of 3 s when the platform is pushed down and released. What must be the mass of a block that when placed on the platform doubles the period of oscillation to 6 s?
- (A) 1 kg
 (B) 2 kg
 (C) 4 kg
 (D) 6 kg
 (E) 8 kg

61. The acceleration of a satellite of mass m in a circular orbit of radius R around a planet of mass M is equal to which of the following?

- (A) $G \frac{M}{R^2}$
 (B) $G \frac{m}{R^2}$
 (C) $G \frac{mM}{R^2}$
 (D) $G \frac{mM}{R}$
 (E) $GmMR$

62. Two identical containers hold two different ideal gases, X and Y , at the same temperature. The number of moles of each gas is the same. The molecular mass of gas X is twice that of gas Y . The ratio of the pressure of X to that of Y is

- (A) $1/2$
 (B) 1
 (C) $\sqrt{2}$
 (D) 2
 (E) 4

63. If three resistors with unequal resistance are connected in parallel in a DC circuit, which of the following is true of the total resistance?

- (A) It is higher than the value of the highest resistance.
 (B) It is equal to the middle resistance.
 (C) It is equal to the average of the three resistances.
 (D) It is lower than the value of the lowest resistance.
 (E) It cannot be determined without knowing the emf applied across the combination.

GO ON TO THE NEXT PAGE.

64. A tuning fork is used to create standing waves in a tube open at the top and partially filled with water. A resonance is heard when the water level is at a certain height. The next resonance is heard when the water level has been lowered by 0.5 m. If the speed of sound is equal to 340 m/s, the frequency of the tuning fork is
- (A) 170 Hz
 (B) 226 Hz
 (C) 340 Hz
 (D) 680 Hz
 (E) 2450 Hz

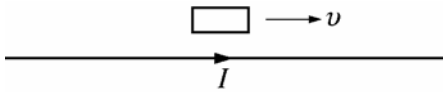

65. A rectangular loop of wire moves at constant speed v parallel to a long wire carrying a current I , as shown above. Which of the following describes the current, if any, induced in the loop?
- (A) A constant clockwise current
 (B) A constant counterclockwise current
 (C) An increasing current
 (D) A decreasing current
 (E) No current

67. In an x-ray tube, electrons striking a target are brought to rest, causing x-rays to be emitted. In a particular x-ray tube, the maximum frequency of the emitted continuum x-ray spectrum is f_0 . If the voltage across the tube is doubled, the maximum frequency is

- (A) $\frac{f_0}{2}$
 (B) $\frac{f_0}{\sqrt{2}}$
 (C) f_0
 (D) $\sqrt{2}f_0$
 (E) $2f_0$

68. A diffraction grating is illuminated by light of wavelength 600 nm. On a screen 100 cm away is a series of bright spots spaced 10 cm apart. If the screen is now placed 30 cm from the diffraction grating, the new spacing between adjacent bright spots on the screen is most nearly

- (A) 30 cm
 (B) 10 cm
 (C) 3 cm
 (D) 1 cm
 (E) 3 mm

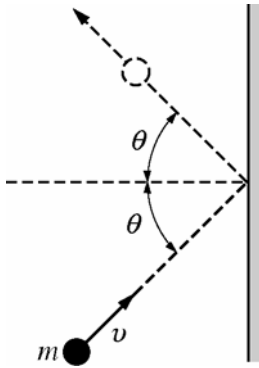

66. A ball of mass m with speed v strikes a wall at an angle θ with the normal, as shown above. It then rebounds with the same speed and at the same angle. The impulse delivered by the ball to the wall is
- (A) zero
 (B) $mv \sin \theta$
 (C) $mv \cos \theta$
 (D) $2mv \sin \theta$
 (E) $2mv \cos \theta$

GO ON TO THE NEXT PAGE.

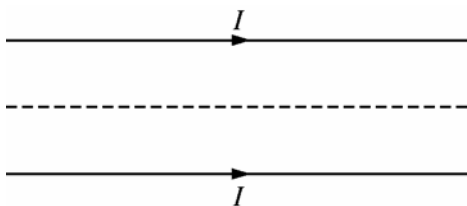

69. Two long, straight, parallel wires in the plane of the page carry equal currents I in the same direction, as shown above. Which of the following correctly describes the forces acting on the wires and the resultant magnetic field at points along the dotted line midway between the wires?

<u>Forces</u>	<u>Field</u>
(A) Attractive	Not zero
(B) Attractive	Zero
(C) Zero	Zero
(D) Repulsive	Not zero
(E) Repulsive	Zero

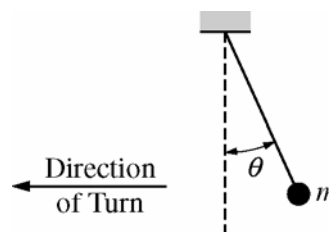

70. An object of mass m hangs from a string that is fixed to the ceiling of a car. At the instant shown above, the car is moving into the plane of the page at constant speed v as it turns to the left around a horizontal curve of radius r . Which of the following is a correct expression for the angle θ of the string with respect to the vertical?

- (A) $\cos \theta = \frac{mg}{r}$
- (B) $\cos \theta = \frac{mv}{r}$
- (C) $\sin \theta = \frac{mv^2}{r}$
- (D) $\tan \theta = \frac{v^2}{gr}$
- (E) $\tan \theta = \frac{gr}{v^2}$

S T O P

END OF SECTION I

**IF YOU FINISH BEFORE TIME IS CALLED
YOU MAY CHECK YOUR WORK ON THIS SECTION.**

DO NOT GO ON TO SECTION II UNTIL YOU ARE TOLD TO DO SO.

Section II

Free-Response Questions

TABLE OF INFORMATION FOR 2008 and 2009

CONSTANTS AND CONVERSION FACTORS	
Proton mass, $m_p = 1.67 \times 10^{-27}$ kg	Electron charge magnitude, $e = 1.60 \times 10^{-19}$ C
Neutron mass, $m_n = 1.67 \times 10^{-27}$ kg	1 electron volt, $1 \text{ eV} = 1.60 \times 10^{-19}$ J
Electron mass, $m_e = 9.11 \times 10^{-31}$ kg	Speed of light, $c = 3.00 \times 10^8$ m/s
Avogadro's number, $N_0 = 6.02 \times 10^{23}$ mol ⁻¹	Universal gravitational constant, $G = 6.67 \times 10^{-11}$ m ³ /kg·s ²
Universal gas constant, $R = 8.31$ J/(mol·K)	Acceleration due to gravity at Earth's surface, $g = 9.8$ m/s ²
Boltzmann's constant, $k_B = 1.38 \times 10^{-23}$ J/K	
1 unified atomic mass unit,	$1 \text{ u} = 1.66 \times 10^{-27}$ kg = $931 \text{ MeV}/c^2$
Planck's constant,	$h = 6.63 \times 10^{-34}$ J·s = 4.14×10^{-15} eV·s
	$hc = 1.99 \times 10^{-25}$ J·m = 1.24×10^3 eV·nm
Vacuum permittivity,	$\epsilon_0 = 8.85 \times 10^{-12}$ C ² /N·m ²
Coulomb's law constant, $k = 1/4\pi\epsilon_0 = 9.0 \times 10^9$ N·m ² /C ²	
Vacuum permeability,	$\mu_0 = 4\pi \times 10^{-7}$ (T·m)/A
Magnetic constant, $k' = \mu_0/4\pi = 10^{-7}$ (T·m)/A	
1 atmosphere pressure,	$1 \text{ atm} = 1.0 \times 10^5$ N/m ² = 1.0×10^5 Pa

UNIT SYMBOLS	meter,	m	mole,	mol	watt,	W	farad,	F
	kilogram,	kg	hertz,	Hz	coulomb,	C	tesla,	T
	second,	s	newton,	N	volt,	V	degree Celsius,	°C
	ampere,	A	pascal,	Pa	ohm,	Ω	electron-volt,	eV
	kelvin,	K	joule,	J	henry,	H		

PREFIXES		
Factor	Prefix	Symbol
10 ⁹	giga	G
10 ⁶	mega	M
10 ³	kilo	k
10 ⁻²	centi	c
10 ⁻³	milli	m
10 ⁻⁶	micro	μ
10 ⁻⁹	nano	n
10 ⁻¹²	pico	p

VALUES OF TRIGONOMETRIC FUNCTIONS FOR COMMON ANGLES							
θ	0°	30°	37°	45°	53°	60°	90°
$\sin \theta$	0	1/2	3/5	$\sqrt{2}/2$	4/5	$\sqrt{3}/2$	1
$\cos \theta$	1	$\sqrt{3}/2$	4/5	$\sqrt{2}/2$	3/5	1/2	0
$\tan \theta$	0	$\sqrt{3}/3$	3/4	1	4/3	$\sqrt{3}$	∞

The following conventions are used in this exam.

- I. Unless otherwise stated, the frame of reference of any problem is assumed to be inertial.
- II. The direction of any electric current is the direction of flow of positive charge (conventional current).
- III. For any isolated electric charge, the electric potential is defined as zero at an infinite distance from the charge.
- IV. For mechanics and thermodynamics equations, W represents the work done on a system.

ADVANCED PLACEMENT PHYSICS B EQUATIONS FOR 2008 and 2009

NEWTONIAN MECHANICS		ELECTRICITY AND MAGNETISM	
$v = v_0 + at$	$a =$ acceleration	$F = \frac{1}{4\pi\epsilon_0} \frac{q_1q_2}{r^2}$	$A =$ area
$x = x_0 + v_0t + \frac{1}{2}at^2$	$F =$ force	$\mathbf{E} = \frac{\mathbf{F}}{q}$	$B =$ magnetic field
$v^2 = v_0^2 + 2a(x - x_0)$	$f =$ frequency	$U_E = qV = \frac{1}{4\pi\epsilon_0} \frac{q_1q_2}{r}$	$C =$ capacitance
$\Sigma \mathbf{F} = \mathbf{F}_{net} = m\mathbf{a}$	$h =$ height	$E_{avg} = -\frac{V}{d}$	$d =$ distance
$F_{fric} \leq \mu N$	$J =$ impulse	$V = \frac{1}{4\pi\epsilon_0} \sum_i \frac{q_i}{r_i}$	$E =$ electric field
$a_c = \frac{v^2}{r}$	$K =$ kinetic energy	$C = \frac{Q}{V}$	$\mathcal{E} =$ emf
$\tau = rF \sin \theta$	$k =$ spring constant	$C = \frac{\epsilon_0 A}{d}$	$F =$ force
$\mathbf{p} = m\mathbf{v}$	$\ell =$ length	$U_c = \frac{1}{2}QV = \frac{1}{2}CV^2$	$I =$ current
$\mathbf{J} = \mathbf{F}\Delta t = \Delta \mathbf{p}$	$m =$ mass	$I_{avg} = \frac{\Delta Q}{\Delta t}$	$\ell =$ length
$K = \frac{1}{2}mv^2$	$N =$ normal force	$R = \frac{\rho \ell}{A}$	$P =$ power
$\Delta U_g = mgh$	$P =$ power	$V = IR$	$Q =$ charge
$W = F\Delta r \cos \theta$	$p =$ momentum	$P = IV$	$q =$ point charge
$P_{avg} = \frac{W}{\Delta t}$	$r =$ radius or distance	$C_p = \sum_i C_i$	$R =$ resistance
$P = Fv \cos \theta$	$T =$ period	$\frac{1}{C_s} = \sum_i \frac{1}{C_i}$	$r =$ distance
$\mathbf{F}_s = -k\mathbf{x}$	$t =$ time	$R_s = \sum_i R_i$	$t =$ time
$U_s = \frac{1}{2}kx^2$	$U =$ potential energy	$\frac{1}{R_p} = \sum_i \frac{1}{R_i}$	$U =$ potential (stored) energy
$T_s = 2\pi\sqrt{\frac{m}{k}}$	$v =$ velocity or speed	$F_B = qvB \sin \theta$	$V =$ electric potential or potential difference
$T_p = 2\pi\sqrt{\frac{\ell}{g}}$	$W =$ work done on a system	$F_B = BI\ell \sin \theta$	$v =$ velocity or speed
$T = \frac{1}{f}$	$x =$ position	$B = \frac{\mu_0 I}{2\pi r}$	$\rho =$ resistivity
$F_G = -\frac{Gm_1m_2}{r^2}$	$\mu =$ coefficient of friction	$\phi_m = BA \cos \theta$	$\theta =$ angle
$U_G = -\frac{Gm_1m_2}{r}$	$\theta =$ angle	$\mathcal{E}_{avg} = -\frac{\Delta\phi_m}{\Delta t}$	$\phi_m =$ magnetic flux
	$\tau =$ torque	$\mathcal{E} = B\ell v$	

ADVANCED PLACEMENT PHYSICS B EQUATIONS FOR 2008 and 2009

FLUID MECHANICS AND THERMAL PHYSICS

$P = P_0 + \rho gh$	$A = \text{area}$
$F_{buoy} = \rho Vg$	$e = \text{efficiency}$
$A_1v_1 = A_2v_2$	$F = \text{force}$
$P + \rho gy + \frac{1}{2}\rho v^2 = \text{const.}$	$h = \text{depth}$
$\Delta\ell = \alpha\ell_0\Delta T$	$H = \text{rate of heat transfer}$
$H = \frac{kA\Delta T}{L}$	$k = \text{thermal conductivity}$
$P = \frac{F}{A}$	$K_{avg} = \text{average molecular kinetic energy}$
$PV = nRT = Nk_B T$	$\ell = \text{length}$
$K_{avg} = \frac{3}{2}k_B T$	$L = \text{thickness}$
$v_{rms} = \sqrt{\frac{3RT}{M}} = \sqrt{\frac{3k_B T}{\mu}}$	$M = \text{molar mass}$
$W = -P\Delta V$	$n = \text{number of moles}$
$\Delta U = Q + W$	$N = \text{number of molecules}$
$e = \left \frac{W}{Q_H} \right $	$P = \text{pressure}$
$e_c = \frac{T_H - T_C}{T_H}$	$Q = \text{heat transferred to a system}$
	$T = \text{temperature}$
	$U = \text{internal energy}$
	$V = \text{volume}$
	$v = \text{velocity or speed}$
	$v_{rms} = \text{root-mean-square velocity}$
	$W = \text{work done on a system}$
	$y = \text{height}$
	$\alpha = \text{coefficient of linear expansion}$
	$\mu = \text{mass of molecule}$
	$\rho = \text{density}$

ATOMIC AND NUCLEAR PHYSICS

$E = hf = pc$	$E = \text{energy}$
$K_{max} = hf - \phi$	$f = \text{frequency}$
$\lambda = \frac{h}{p}$	$K = \text{kinetic energy}$
$\Delta E = (\Delta m)c^2$	$m = \text{mass}$
	$p = \text{momentum}$
	$\lambda = \text{wavelength}$
	$\phi = \text{work function}$

WAVES AND OPTICS

$v = f\lambda$	$d = \text{separation}$
$n = \frac{c}{v}$	$f = \text{frequency or focal length}$
$n_1 \sin \theta_1 = n_2 \sin \theta_2$	$h = \text{height}$
$\sin \theta_c = \frac{n_2}{n_1}$	$L = \text{distance}$
$\frac{1}{s_i} + \frac{1}{s_o} = \frac{1}{f}$	$M = \text{magnification}$
$M = \frac{h_i}{h_o} = -\frac{s_i}{s_o}$	$m = \text{an integer}$
$f = \frac{R}{2}$	$n = \text{index of refraction}$
$d \sin \theta = m\lambda$	$R = \text{radius of curvature}$
$x_m \sim \frac{m\lambda L}{d}$	$s = \text{distance}$
	$v = \text{speed}$
	$x = \text{position}$
	$\lambda = \text{wavelength}$
	$\theta = \text{angle}$

GEOMETRY AND TRIGONOMETRY

Rectangle	$A = \text{area}$
$A = bh$	$C = \text{circumference}$
Triangle	$V = \text{volume}$
$A = \frac{1}{2}bh$	$S = \text{surface area}$
Circle	$b = \text{base}$
$A = \pi r^2$	$h = \text{height}$
$C = 2\pi r$	$\ell = \text{length}$
Parallelepiped	$w = \text{width}$
$V = \ell wh$	$r = \text{radius}$
Cylinder	
$V = \pi r^2 \ell$	
$S = 2\pi r \ell + 2\pi r^2$	
Sphere	
$V = \frac{4}{3}\pi r^3$	
$S = 4\pi r^2$	
Right Triangle	
$a^2 + b^2 = c^2$	
$\sin \theta = \frac{a}{c}$	
$\cos \theta = \frac{b}{c}$	
$\tan \theta = \frac{a}{b}$	

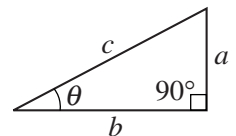

PHYSICS B
SECTION II
Time—90 minutes
7 Questions

Directions: Answer all seven questions, which are weighted according to the points indicated. The suggested times are about 11 minutes for answering each of Questions 1 and 4-7 and about 17 minutes for answering each of Questions 2-3. The parts within a question may not have equal weight. All final numerical answers should include appropriate units. Credit depends on the quality of your solutions and explanations, so you should show your work. Credit also depends on demonstrating that you know which physical principles would be appropriate to apply in a particular situation. Therefore, you should clearly indicate which part of a question your work is for.

1. (10 points)

A toy cart of mass 0.50 kg moves across a horizontal table with constant acceleration. Its position x is measured for different times t , and the data are recorded in the table below.

Time t (s)	Position x (m)	Average Speed \bar{v} (m/s)
0.00	0.20	
0.50	0.42	
1.00	0.90	
1.50	1.55	
2.00	2.30	

- (a) Calculate the average speed of the cart during each 0.50 s time interval and fill in the blank spaces in the table above.
- (b) On the axes below, label the vertical axis with appropriate numbers, plot the data, and draw a best-fit line to show a graph of velocity versus time for the cart.

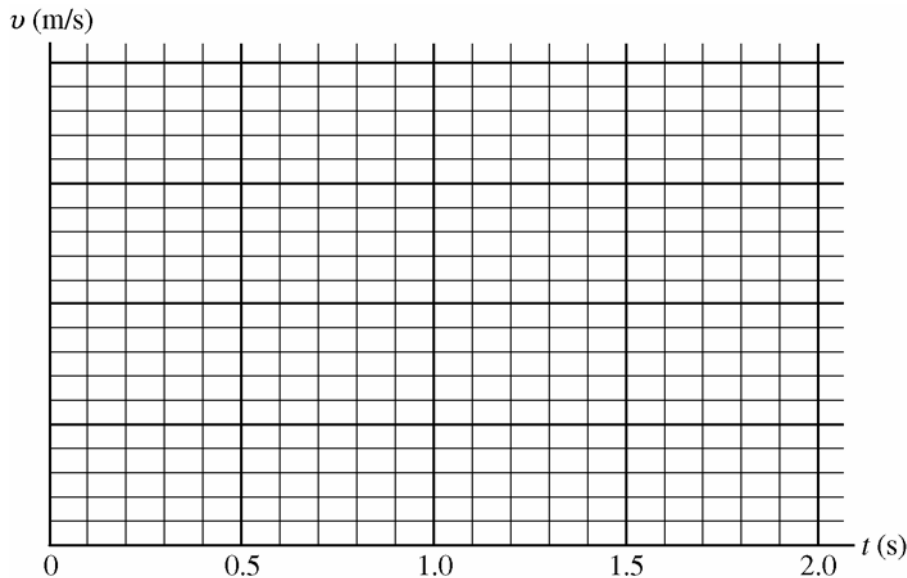

- (c) Using the best-fit line, calculate the acceleration of the cart.
- (d) The cart continues with the constant acceleration calculated in (c) until it reaches the edge of the table at $t = 3.0$ s. It then falls to the floor, which is 1.2 m below the tabletop. Calculate the kinetic energy of the cart just before hitting the floor.

GO ON TO THE NEXT PAGE.

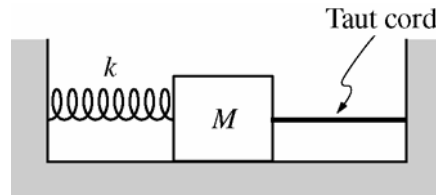

2. (15 points)

One end of a spring of spring constant k is attached to a wall, and the other end is attached to a block of mass M , as shown above. The block is pulled to the right, stretching the spring from its equilibrium position, and is then held in place by a taut cord, the other end of which is attached to the opposite wall. The spring and the cord have negligible mass, and the tension in the cord is F_T . Friction between the block and the surface is negligible. Express all algebraic answers in terms of M , k , F_T , and fundamental constants.

(a) On the dot below that represents the block, draw and label a free-body diagram for the block.



(b) Calculate the distance that the spring has been stretched from its equilibrium position.

The cord suddenly breaks so that the block initially moves to the left and then oscillates back and forth.

(c) Calculate the speed of the block when it has moved half the distance from its release point to its equilibrium position.

(d) Calculate the time after the cord breaks until the block first reaches its position furthest to the left.

(e) Suppose instead that friction is not negligible and that the coefficient of kinetic friction between the block and the surface is μ_k . After the cord breaks, the block again initially moves to the left. Calculate the initial acceleration of the block just after the cord breaks.

GO ON TO THE NEXT PAGE.

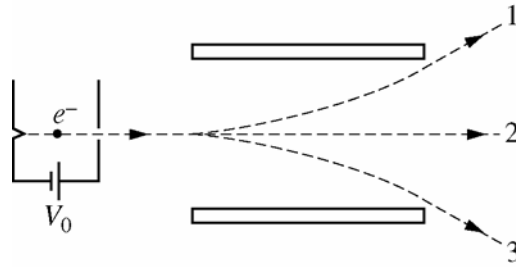

3. (15 points)

Electrons are accelerated from rest through a potential difference V_0 and then pass through a region between two parallel metal plates, as shown above. The region between the plates can contain a uniform electric field \mathbf{E} and a uniform magnetic field \mathbf{B} . With only the electric field present, the electrons follow path 1. With only the magnetic field present, the electrons follow path 3. As drawn, the curved paths between the plates show the correct direction of deflection for each field, but not necessarily the correct path shape. With both fields present, the electrons pass undeflected along the straight path 2.

(a)

i. Which of the following describes the shape of the portion of path 1 between the plates?

Circular Parabolic Hyperbolic Exponential

Justify your answer.

ii. What is the direction of the electric field?

To the left To the top of the page Into the page
 To the right To the bottom of the page Out of the page

Justify your answer.

(b)

i. Which of the following describes the shape of the portion of path 3 between the plates?

Circular Parabolic Hyperbolic Exponential

Justify your answer.

ii. What is the direction of the magnetic field?

To the left To the top of the page Into the page
 To the right To the bottom of the page Out of the page

Justify your answer.

Between the plates the magnitude of the electric field is 3.4×10^4 V/m, and the magnitude of the magnetic field is 2.0×10^{-3} T.

(c) Calculate the speed of the electrons given that they are undeflected when both fields are present.

(d) Calculate the potential difference V_0 required to accelerate the electrons to the speed determined in part (c).

GO ON TO THE NEXT PAGE.

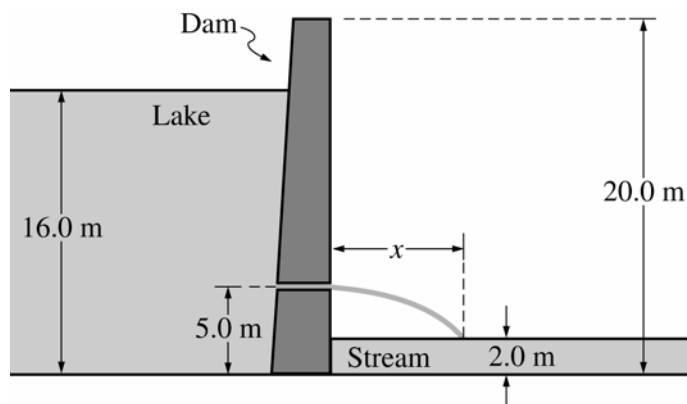

4. (10 points)

A 20 m high dam is used to create a large lake. The lake is filled to a depth of 16 m as shown above. The density of water is 1000 kg/m^3 .

(a) Calculate the absolute pressure at the bottom of the lake next to the dam.

A release valve is opened 5.0 m above the base of the dam, and water exits horizontally from the valve.

(b) Use Bernoulli's equation to calculate the initial speed of the water as it exits the valve.

(c) The stream below the surface of the dam is 2.0 m deep. Assuming that air resistance is negligible, calculate the horizontal distance x from the dam at which the water exiting the valve strikes the surface of the stream.

(d) Suppose that the atmospheric pressure in the vicinity of the dam increased. How would this affect the initial speed of the water as it exits the valve?

___ It would increase. ___ It would decrease. ___ It would remain the same.

Justify your answer.

GO ON TO THE NEXT PAGE.

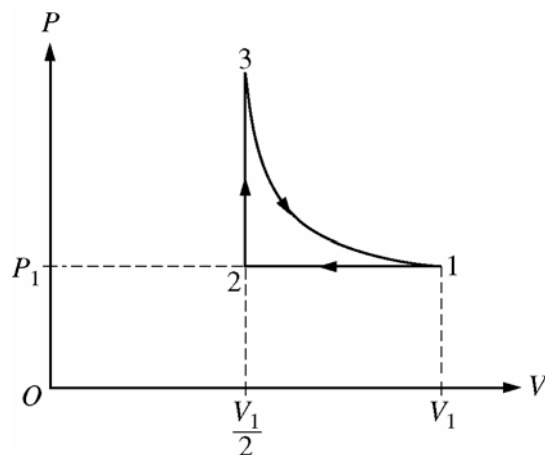

5. (10 points)

A sample of n moles of an ideal gas, originally at a pressure P_1 and volume V_1 , undergoes the three processes shown on the PV diagram above:

Process 1 \rightarrow 2: The volume is halved while the pressure remains constant.

Process 2 \rightarrow 3: The pressure is increased while the volume remains constant until the temperature reaches its original value.

Process 3 \rightarrow 1: The volume is increased while the temperature remains constant until the volume reaches its original value.

(a) Determine expressions for each of the following in terms of P_1 , V_1 , n , and fundamental constants.

i. The temperature of the gas in state 1

ii. The pressure of the gas in state 3

iii. The total work done on the gas during processes 1 \rightarrow 2 and 2 \rightarrow 3

(b) Indicate below whether heat is added to the gas, removed from the gas, or neither during the process 2 \rightarrow 3.

___ Added to ___ Removed from ___ Neither added to nor removed from

Justify your answer.

(c) Indicate below whether heat is added to the gas, removed from the gas, or neither during the process 3 \rightarrow 1.

___ Added to ___ Removed from ___ Neither added to nor removed from

Justify your answer.

GO ON TO THE NEXT PAGE.

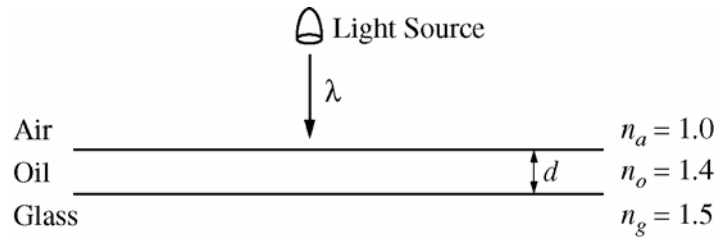

6. (10 points)

In a classroom demonstration of thin films, your physics teacher takes a glass plate and places a thin layer of transparent oil on top of it. The oil film is then illuminated by shining a narrow beam of white light perpendicularly onto the oil's surface, as shown above. The indices of refraction of air, the oil, and the glass plate are given in the diagram. Standing near the light source, you observe that the film appears green. This corresponds to a wavelength of 520 nm.

- (a) Determine each of the following for the green light.
 - i. The frequency of the light in air
 - ii. The frequency of the light in the oil film
 - iii. The wavelength of the light in the oil film
- (b) Calculate the minimum thickness of the oil film (other than zero) such that the observed green light is the most intense.
- (c) As your teacher changes the angle of the light source, the light you observe from the film changes color. Give an explanation for this phenomenon.



7. (10 points)

The diagram above shows a portion of the energy-level diagram for a particular atom. When the atom undergoes transition I, the wavelength of the emitted radiation is 400 nm, and when it undergoes transition II, the wavelength is 700 nm.

- (a) Calculate the wavelength of the emitted radiation when the atom undergoes transition III.
- A photon emitted during transition III is then incident on a metal surface of work function 2.1 eV.
- (b) Calculate the maximum kinetic energy of the electron ejected from the metal by the photon.
 - (c) Calculate the de Broglie wavelength of the ejected electron.

STOP

END OF EXAM

Name: _____

AP[®] Physics B
Student Answer Sheet for Multiple-Choice Section

No.	Answer
1	
2	
3	
4	
5	
6	
7	
8	
9	
10	
11	
12	
13	
14	
15	
16	
17	
18	
19	
20	
21	
22	
23	
24	
25	
26	
27	
28	
29	
30	

No.	Answer
31	
32	
33	
34	
35	
36	
37	
38	
39	
40	
41	
42	
43	
44	
45	
46	
47	
48	
49	
50	
51	
52	
53	
54	
55	
56	
57	
58	
59	
60	

No.	Answer
61	
62	
63	
64	
65	
66	
67	
68	
69	
70	

AP[®] Physics B
Multiple-Choice Answer Key

No.	Correct Answer
1	C
2	C
3	A
4	A
5	B
6	D
7	B
8	E
9	A
10	C
11	A
12	B
13	D
14	C
15	E
16	E
17	D
18	E
19	C
20	A
21	A
22	E
23	B
24	B
25	B
26	C
27	E
28	A
29	D
30	E

No.	Correct Answer
31	A
32	C
33	A
34	A
35	C
36	E
37	B
38	E
39	A
40	A
41	D
42	A
43	E
44	D
45	D
46	C
47	C
48	E
49	B
50	B
51	A
52	D
53	C
54	B
55	C
56	C
57	E
58	D
59	B
60	D

No.	Correct Answer
61	A
62	B
63	D
64	C
65	E
66	E
67	E
68	C
69	B
70	D

AP[®] Physics B

Free-Response Scoring Guidelines

General Notes about AP Physics Practice Exam Scoring Guidelines

1. The solutions contain a common method of solving the free-response questions and the allocation of points for this solution. Some also contain a common alternate solution. They are typical of draft guidelines developed before student solutions are available. Teachers should feel free to make modifications based on their students' responses.
2. The scoring guidelines typically show numerical results using the value $g = 9.8 \text{ m/s}^2$, but use of 10 m/s^2 is of course also acceptable. Solutions usually show numerical answers using both values when they are significantly different.

The following rules apply to the official scoring of AP Physics Exams.

3. All correct methods of solution receive appropriate credit for correct work.
4. Generally, double penalty for errors is avoided. For example, if an incorrect answer to part (a) is correctly substituted into an otherwise correct solution to part (b), full credit will usually be awarded. One exception to this may be cases when the numerical answer to a later part should be easily recognized as wrong, e.g., a speed faster than the speed of light in vacuum.
5. Implicit statements of concepts normally receive credit. For example, if use of the equation expressing a particular concept is worth 1 point, and a student's solution contains the application of that equation to the problem but the student does not write the basic equation, the point is still awarded. However, when students are asked to derive an expression, it is normally expected that they will begin by writing one or more fundamental equations, such as those given on the AP Physics Exam equation sheet. For a description of the use of such terms as "derive" and "calculate" on the exams, and what is expected for each, see "The Free-Response Sections—Student Presentation" in the *AP Physics Course Description*.
6. Strict rules regarding significant digits are usually not applied to numerical answers. However, in some cases answers containing too many digits may be penalized. In general, two to four significant digits are acceptable. Numerical answers that differ from the published answer due to differences in rounding throughout the question typically receive full credit. Exceptions to these guidelines usually occur when rounding makes a difference in obtaining a reasonable answer. For example, suppose a solution requires subtracting two numbers that should have five significant figures and that differ starting with the fourth digit (e.g., 20.295 and 20.278). Rounding to three digits will lose the accuracy required to determine the difference in the numbers, and some credit may be lost.

AP[®] Physics B
Free-Response Scoring Guidelines

Question 1

10 points total

**Distribution
of points**

(a) 2 points

Time t (s)	Position x (m)	Average Speed \bar{v} (m/s)
0.00	0.20	0.44
0.50	0.42	0.96
1.00	0.90	1.30
1.50	1.55	1.50
2.00	2.30	

For all values for average speed correct in the table

2 points

Note: 1 point partial credit may be given if one value is incorrect but evidence is shown that $\bar{v} = \Delta x / t$ was used in calculating the average speed.

(b) 3 points

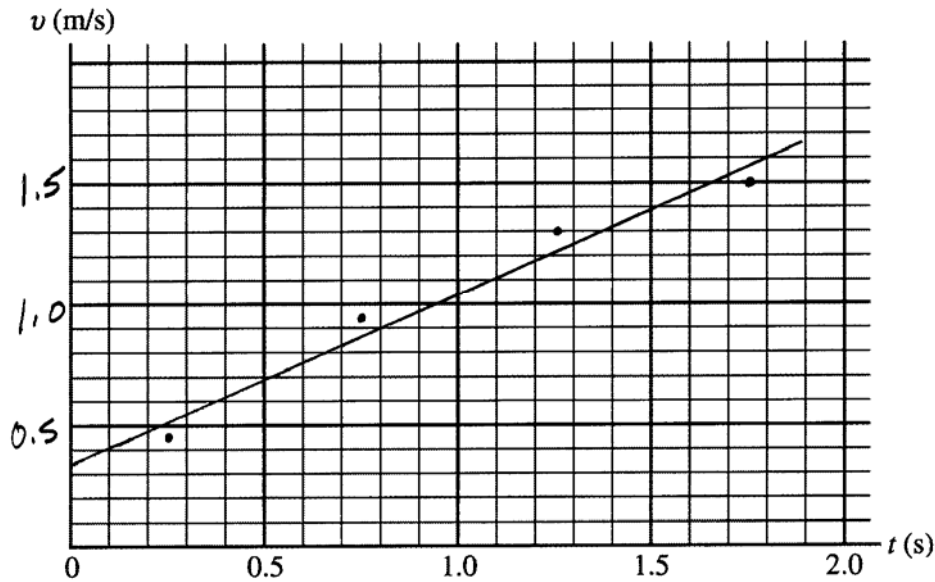

For labeling the vertical axis with numbers appropriate for the range of values of average speed obtained in (a) 1 point

For at least three data points plotted correctly using the midpoint of each time interval rather than either end point (For constant acceleration, the average speed during an interval is equal to the speed at the midpoint.) 1 point

For drawing a reasonable straight line fit that has two data points above the line and two data points below the line 1 point

AP[®] Physics B
Free-Response Scoring Guidelines

Question 1 (continued)

	Distribution of points
(c) 2 points	
For an indication that the acceleration is the slope of the best-fit line $a = \Delta v / \Delta t = \text{slope}$	1 point
For correctly choosing two points on the line to calculate the slope For example, using the graph shown above and selecting points (1.8, 1.6) and (0.1, 0.4)	1 point
$a = \frac{1.6 \text{ m/s} - 0.40 \text{ m/s}}{1.8 \text{ s} - 0.10 \text{ s}}$ $a = 0.71 \text{ m/s}^2$	
(d) 3 points	
For a correct calculation of the speed at $t = 3.0 \text{ s}$ $v = v_0 + at$	1 point
Using the intercept $v_0 = 0.35 \text{ m/s}$ from the graph, and $a = 0.71 \text{ m/s}^2$ from part (c) $v = 0.35 \text{ m/s} + (0.71 \text{ m/s}^2)(3.0 \text{ s}) = 2.5 \text{ m/s}$	
For a correct expression for the final kinetic energy that includes both potential and kinetic energy terms $K = mgh + \frac{1}{2}mv^2$	1 point
For correct substitutions $K = (0.50 \text{ kg})(9.8 \text{ m/s}^2)(1.2 \text{ m}) + \frac{1}{2}(0.50 \text{ kg})(2.5 \text{ m/s})^2$ $K = 7.4 \text{ J}$	1 point
<u>Note:</u> Answers ranging from 7.2 to 7.8 may be obtained, depending on the value of g used and the values of v_0 and a obtained from the graph.	

AP[®] Physics B
Free-Response Scoring Guidelines

Question 2

15 points total

**Distribution
of points**

(a) 4 points

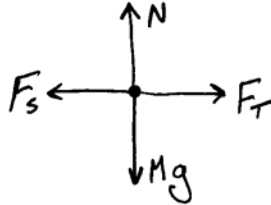

For each correctly drawn and labeled force, award 1 point

4 points

Note: 1 point is deducted for each incorrect force vector shown, up to 4 points.

(b) 2 points

For indicating that the forces exerted by the spring and the cord are equal in magnitude

1 point

$$F_T = F_S = kx_0$$

For the correct expression for x_0

1 point

$$x_0 = F_T/k$$

(c) 4 points

For a correct expression of conservation of energy relating both kinetic and potential energies

1 point

$$U_{S,final} + K = U_{S,initial}$$

For a correct equation relating v and x_0

1 point

$$\frac{1}{2}k\left(\frac{x_0}{2}\right)^2 + \frac{1}{2}Mv^2 = \frac{1}{2}kx_0^2$$

$$\frac{1}{8}kx_0^2 + \frac{1}{2}Mv^2 = \frac{1}{2}kx_0^2$$

$$\frac{1}{2}Mv^2 = \frac{3}{8}kx_0^2$$

$$v = \frac{x_0}{2} \sqrt{\frac{3k}{M}}$$

For the correct substitution of $x_0 = F_T/k$ from part (b)

1 point

$$v = \frac{F_T}{2k} \sqrt{\frac{3k}{M}}$$

For the correct expression for v

1 point

$$v = \frac{F_T}{2} \sqrt{\frac{3}{kM}}$$

AP[®] Physics B
Free-Response Scoring Guidelines

Question 2 (continued)

	Distribution of points
(d) 2 points	
For an indication that the time desired is one-half of the period of oscillation of the block	1 point
$t = \frac{T}{2}$	
The period of oscillation of the block is given by	
$T = 2\pi\sqrt{\frac{M}{k}}$	
For the correct expression for the time	1 point
$t = \pi\sqrt{\frac{M}{k}}$	
(e) 3 points	
For a correct expression of Newton's second law involving both the forces exerted by the spring and by friction	1 point
$Ma = F_S - F_{friction}$	
For correctly substituting $F_S = kx_0$ and $F_{friction} = \mu_k Mg$	1 point
$Ma = kx_0 - \mu_k Mg$	
$a = \frac{kx_0}{M} - \mu_k g$	
Substituting $x_0 = F_T/k$ from (b)	
$a = \frac{kF_T}{Mk} - \mu_k g$	
For the correct expression for the acceleration	1 point
$a = \frac{F_T}{M} - \mu_k g$	

AP[®] Physics B
Free-Response Scoring Guidelines

Question 3

15 points total

**Distribution
of points**

(a)

(i) 3 points

For indicating that the path is parabolic

1 point

For a correct justification that includes descriptions of the motion of the electrons in both the horizontal and vertical directions

2 points

For example: The electrons have constant speed to the right. The constant electric force provides a constant acceleration toward the top of the page. This is similar to a projectile under the influence of gravity, so the shape is parabolic.

Note: 1 point partial credit may be awarded for a partially complete justification.

(ii) 2 points

For indicating that the electric field points toward the bottom of the page

1 point

For a correct justification

1 point

For example: To create path 1, the electric force must be toward the top of the page. The electron is negatively charged, so the field must point in the opposite direction to the electric force.

(b)

(i) 2 points

For indicating that the path is circular

1 point

For a correct justification

1 point

For example: The magnetic force is always perpendicular to the velocity of the electrons and has constant magnitude. Thus it acts as a centripetal force making the electrons follow a circular path.

(ii) 2 points

For indicating that the magnetic field points into the page

1 point

For a correct justification

1 point

For example: To create path 3, the initial magnetic force must be toward the bottom of the page. With the initial velocity to the right, the right-hand rule gives a field pointing out of the page. But the electron is negatively charged, so the field must point in the opposite direction.

AP[®] Physics B
Free-Response Scoring Guidelines

Question 3 (continued)

	Distribution of points
(c) 3 points	
For an indication that the electric and magnetic forces are equal in magnitude $F_E = F_B$	1 point
For substitutions of the correct expressions for these forces in terms of the fields $evB = eE$ $v = E/B$	1 point
Substituting the numerical values given for E and B $v = (3.4 \times 10^4 \text{ V/m}) / (2.0 \times 10^{-3} \text{ T})$	
For the correct numerical answer with units $v = 1.7 \times 10^7 \text{ m/s}$	1 point
(d) 3 points	
For an indication that the change in potential energy of the electrons is equal to their kinetic energy $\Delta U_E = K$	1 point
For substitutions of the correct expressions for these quantities $eV_0 = \frac{1}{2}m_e v^2$ $V_0 = \frac{m_e v^2}{2e}$	1 point
Substituting the numerical values of m_e , e , and the value of v from part (c) $V_0 = \frac{(9.11 \times 10^{-31} \text{ kg})(1.7 \times 10^7 \text{ m/s})^2}{2(1.6 \times 10^{-19} \text{ C})}$	
For the correct numerical answer with units $V_0 = 823 \text{ V}$	1 point

AP[®] Physics B
Free-Response Scoring Guidelines

Question 4

10 points total

**Distribution
of points**

(a) 2 points

For an indication that the absolute pressure is the sum of the atmospheric pressure and the gauge pressure

$$P_{abs} = P_{atm} + \rho gh$$

$$P = 1 \times 10^5 \text{ Pa} + (1000 \text{ kg/m}^3)(9.8 \text{ m/s}^2)(16 \text{ m})$$

For the correct answer with units

$$P = 2.6 \times 10^5 \text{ Pa}$$

1 point

1 point

(b) 3 points

Bernoulli's equation is given in the equation tables as

$$P + \rho gy + \frac{1}{2} \rho v^2 = \text{const.}$$

For correctly applying Bernoulli's equation to this situation

$$P_{valve} + \rho gy_{valve} + \frac{1}{2} \rho v_{valve}^2 = P_{lake} + \rho gy_{lake} + \frac{1}{2} \rho v_{lake}^2$$

For recognizing that the pressure at the exit point of the valve is essentially the same as at the top of the lake, and that the speed of the water at the top of the lake is essentially equal to zero

$$\frac{1}{2} \rho v_{valve}^2 = \rho g (y_{lake} - y_{valve})$$

$$v_{valve} = \sqrt{2g(y_{lake} - y_{valve})}$$

For correct substitutions

$$v_{valve} = \sqrt{2(9.8 \text{ m/s}^2)(16.0 \text{ m} - 5.0 \text{ m})}$$

$$v_{valve} = 14.7 \text{ m/s (or } 14.8 \text{ m/s using } g = 10 \text{ m/s}^2)$$

1 point

1 point

1 point

(c) 3 points

For the correct calculation of the time for the water to fall to the surface

$$y = \frac{1}{2} gt^2$$

$$t = \sqrt{2y/g} = \sqrt{2(5.0 \text{ m} - 2.0 \text{ m})/(9.8 \text{ m/s}^2)} = 0.78 \text{ s (or } 0.77 \text{ s using } g = 10 \text{ m/s}^2)$$

For the correct substitutions of v and t into the correct expression for the horizontal distance

$$x = vt = (14.7 \text{ m/s})(0.78 \text{ s})$$

For the correct answer with units

$$x = 11.5 \text{ m (or } 11.4 \text{ m using } g = 10 \text{ m/s}^2 \text{ in the calculations for the speed and time)}$$

1 point

1 point

1 point

AP[®] Physics B
Free-Response Scoring Guidelines

Question 4 (continued)

**Distribution
of points**

(d) 2 points

For indicating that the initial speed of the water would remain the same

1 point

For a correct justification

1 point

For example: When Bernoulli's equation is applied to this situation, atmospheric pressure appears on both sides of the equation and cancels out. So it has no effect on the speed of the exiting water.

AP[®] Physics B
Free-Response Scoring Guidelines

Question 5

10 points total

**Distribution
of points**

(a)

(i) 1 point

For the correct use of the ideal gas law to find the temperature of the gas in state 1

$$P_1V_1 = nRT_1$$

$$T_1 = P_1V_1/nR$$

1 point

(ii) 2 points

For the correct application of the ideal gas law at states 3 and 1

$$\frac{PV}{T} = nR = \text{const}, \text{ so } \frac{P_3V_3}{T_3} = \frac{P_1V_1}{T_1}$$

1 point

For correct substitutions of $T_3 = T_1$ and $V_3 = \frac{V_1}{2}$ to arrive at the correct answer

1 point

$$P_3 \frac{V_1}{2} = P_1V_1$$

$$P_3 = 2P_1$$

(iii) 2 points

$$W = -P\Delta V$$

For recognition that for process 2 → 3, $\Delta V = 0$, so $W_{2 \rightarrow 3} = 0$

1 point

For the correct expression for the work done on the gas during process 1 → 2

1 point

$$W_{1 \rightarrow 2} = -P_1 \left(\frac{V_1}{2} - V_1 \right) = \frac{P_1V_1}{2}$$

$$W_{tot} = W_{1 \rightarrow 2} + W_{2 \rightarrow 3} = \frac{P_1V_1}{2} + 0$$

$$W_{tot} = \frac{P_1V_1}{2}$$

(b) 3 points

For indicating that heat is added to the gas

1 point

For a correct justification

2 points

For example: From the first law of thermodynamics, $\Delta U = Q + W$, it follows that

$$Q = \Delta U - W. \text{ During process } 2 \rightarrow 3 \text{ the volume is constant, so } W = -p\Delta V = 0.$$

The temperature increases and the internal energy is proportional to temperature, so ΔU is positive. Therefore Q is positive. Heat must be added to increase the internal energy.

Note: 1 point partial credit may be given for a partially correct answer.

AP[®] Physics B
Free-Response Scoring Guidelines

Question 5 (continued)

		Distribution of points
(c)	2 points	
	For indicating that heat is added to the gas	1 point
	For a correct justification	1 point
	For example: From the first law of thermodynamics it follows that $Q = \Delta U - W$.	
	Process $3 \rightarrow 1$ is isothermal and since the internal energy is proportional to temperature, $\Delta U = 0$. Therefore $Q = -W = -(-p\Delta V) = p\Delta V$. Since V increases, ΔV is positive.	
	Therefore Q is positive. Heat must be added to maintain the internal energy.	

AP[®] Physics B
Free-Response Scoring Guidelines

Question 6

10 points total

**Distribution
of points**

(a)

(i) 2 points

For a correct expression relating the frequency to the speed and wavelength, with correct substitutions

$$v = f\lambda$$

$$f = v/\lambda$$

$$f_a = (3.00 \times 10^8 \text{ m/s}) / (520 \times 10^{-9} \text{ m})$$

For the correct answer with units

$$f_a = 5.77 \times 10^{14} \text{ Hz}$$

1 point

1 point

(ii) 1 point

For an indication that the frequency in the oil film is the same as the frequency in air

$$f_o = 5.77 \times 10^{14} \text{ Hz}$$

1 point

(iii) 2 points

For a correct expression relating the wavelengths in air and oil to the index of refraction, with correct substitutions

$$n = \frac{c}{v_o} = \frac{f_a \lambda_a}{f_o \lambda_o} = \frac{\lambda_a}{\lambda_o}$$

$$\lambda_o = \lambda_a / n_o$$

$$\lambda_o = (520 \times 10^{-9} \text{ m}) / 1.4$$

For the correct answer with units

$$\lambda_o = 3.71 \times 10^{-7} \text{ m} = 371 \text{ nm}$$

1 point

1 point

(b) 3 points

There are two 180° phase changes as the light is reflected, one as the light reaches the surface of the oil and one at the surface of the glass, so the condition for maximum constructive interference is a path length difference of one wavelength.

For using $2t$ as the path length difference, where t is the thickness of the oil film

For the correct relationship between path length difference and the wavelength in oil

$2t = m\lambda_o$, for any integer m , but $m = 1$ for minimum thickness

$$t = \lambda_o / 2$$

For the correct answer including units

$$t = 1.86 \times 10^{-7} \text{ m} = 186 \text{ nm}$$

1 point

1 point

1 point

AP[®] Physics B
Free-Response Scoring Guidelines

Question 6 (continued)

**Distribution
of points**

(c) 2 points

For a correct explanation

2 points

For example: Light viewed at different angles corresponds to different path lengths in the oil. Each color has a different wavelength, and thus requires a different path length difference for constructive interference.

Note: Partial credit of 1 point may be given for an incomplete answer that, for example, mentions only that the different angles correspond to different path lengths or that each color has a different wavelength.

AP[®] Physics B
Free-Response Scoring Guidelines

Question 7

10 points total

**Distribution
of points**

(a) 3 points

For an indication that the energy of transition III is the sum of the energies of the other two transitions 1 point

$$E_{\text{III}} = E_{\text{I}} + E_{\text{II}}$$

For using the correct expression relating the energy of each transition to its wavelength 1 point

$$E = hf = hc/\lambda$$

$$\frac{hc}{\lambda_{\text{III}}} = \frac{hc}{\lambda_{\text{I}}} + \frac{hc}{\lambda_{\text{II}}}$$

$$\frac{1}{\lambda_{\text{III}}} = \frac{1}{\lambda_{\text{I}}} + \frac{1}{\lambda_{\text{II}}}$$

$$\frac{1}{\lambda_{\text{III}}} = \frac{1}{400 \text{ nm}} + \frac{1}{700 \text{ nm}} = \frac{11}{2800 \text{ nm}}$$

For the correct answer including units 1 point

$$\lambda_{\text{III}} = 255 \text{ nm}$$

(b) 3 points

For a correct expression for the kinetic energy of the photon emitted during transition III 1 point

$$E_{\text{III}} = hf_{\text{III}} = \frac{hc}{\lambda_{\text{III}}}$$

For an indication that the maximum kinetic energy is equal to the transition energy minus the work function 1 point

$$K_{\text{max}} = E_{\text{III}} - \phi = \frac{hc}{\lambda_{\text{III}}} - \phi$$

$$K_{\text{max}} = \frac{1.24 \times 10^3 \text{ eV}\cdot\text{nm}}{255 \text{ nm}} - 2.1 \text{ eV}$$

For the correct answer including units 1 point

$$K_{\text{max}} = 2.80 \text{ eV (or } 4.5 \times 10^{-19} \text{ J)}$$

AP[®] Physics B
Free-Response Scoring Guidelines

Question 7 (continued)

	Distribution of points
(c) 4 points	
For using a correct relationship relating the de Broglie wavelength of the electron to its speed $\lambda = h/p = h/mv$	1 point
For correctly determining the speed of the electron and substituting into the equation above $K_{\max} = \frac{1}{2}mv^2$ $v = \sqrt{2K_{\max}/m}$ $\lambda = h/m\sqrt{2K_{\max}/m}$ $\lambda = h/\sqrt{2mK_{\max}}$	1 point
For correct substitutions $\lambda = (6.63 \times 10^{-34} \text{ J}\cdot\text{s}) / \sqrt{2(9.11 \times 10^{-31} \text{ kg})(2.80 \text{ eV})(1.6 \times 10^{-19} \text{ J/eV})}$	1 point
For the correct answer including units $\lambda = 7.34 \times 10^{-10} \text{ m} = 0.734 \text{ nm}$	1 point