

Released Items

Published January 2019

Grade 5 Mathematics North Carolina End-of-Grade Assessment



Public Schools of North Carolina

Department of Public Instruction | State Board of Education

Division of Accountability Services/North Carolina Testing Program

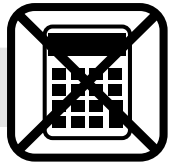

Sample Questions

S1 Jeremy reads 3 books each week. How many books will Jeremy read in 5 weeks?

- A 8
- B 12
- C 15
- D 20

S2 What is $2.0 + 0.7$?

Only 0, 1, 2, 3, 4, 5, 6, 7, 8, 9, ., and / are allowed in your answer. Answers that are mixed numbers must be entered as an improper fraction or decimal.

--	--	--	--



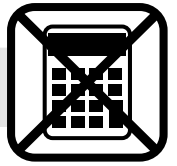

S3 What fraction of the circle is shaded?

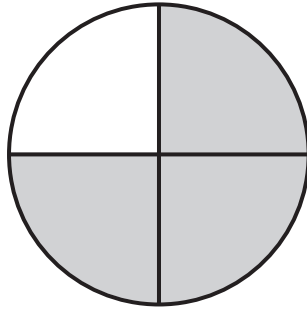

Only 0, 1, 2, 3, 4, 5, 6, 7, 8, 9, ., and / are allowed in your answer. Answers that are mixed numbers must be entered as an improper fraction or decimal.

--	--	--	--	--	--

RELEASED



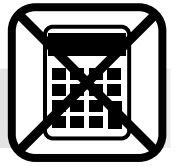

- 1 A supermarket has 238 large boxes of cereal. Each large box holds 32 small bags of cereal. How many small bags of cereal are in the supermarket?
- A 6,506 bags
B 6,616 bags
C 7,506 bags
D 7,616 bags
- 2 Richard walked 15.74 miles and James walked 12.98 miles. How many more miles did Richard walk than James?
- A 2.76
B 2.86
C 3.76
D 3.86
- 3 After basketball practice, 8 players equally shared 3 large bottles of water. What fraction of a bottle did each player get?
- A $\frac{1}{8}$
B $\frac{1}{3}$
C $\frac{3}{8}$
D $\frac{8}{3}$



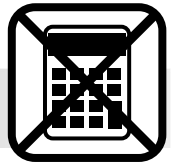

- 4 Joan went to the bookstore.
- At this bookstore, $\frac{3}{4}$ of the books are fiction.
 - Of the fiction books, $\frac{1}{3}$ are mystery books.

What fraction of the books at the bookstore are mystery fiction books?

- A $\frac{1}{4}$
- B $\frac{1}{3}$
- C $\frac{4}{7}$
- D $\frac{4}{5}$
- 5 A school painted $\frac{1}{2}$ of a wall in its gym with 3 colors. Each color takes up the same amount of space on the wall. What fraction of the wall does each color occupy?
- A $\frac{2}{5}$
- B $\frac{1}{3}$
- C $\frac{1}{5}$
- D $\frac{1}{6}$



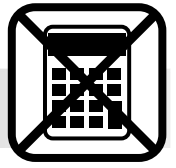

- 6 Tracie ran a total of $5\frac{3}{4}$ miles on Saturday and Sunday. She ran $1\frac{5}{8}$ miles on Saturday. How many miles did Tracie run on Sunday?
- A $3\frac{7}{8}$
- B $4\frac{1}{8}$
- C $4\frac{1}{4}$
- D $4\frac{1}{2}$
- 7 A sports store has 468 golf balls. They will be put into boxes that hold 18 balls each. What is the **minimum** number of boxes needed for all of the golf balls?
- A 26
- B 27
- C 28
- D 29
- 8 Three pizzas are shared equally among 12 people. What fraction of a pizza will each person get?
- A $\frac{4}{1}$
- B $\frac{1}{3}$
- C $\frac{1}{4}$
- D $\frac{1}{12}$

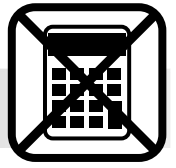

9 What is the value of n in the equation shown?

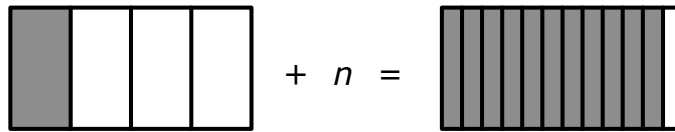

10 Mr. Edwards bought a 50-pound bag of flour for his bakery. It was equally divided among 6 days. How much flour was used per day?

A $\frac{3}{25}$ pound

B $8\frac{1}{3}$ pounds

C $9\frac{1}{6}$ pounds

D 300 pounds



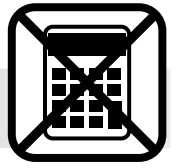

- 11 A rectangular room is $12\frac{1}{2}$ feet long and $10\frac{1}{3}$ feet wide. What is the area of the room?
- A $22\frac{5}{6}$ square feet
- B $120\frac{1}{6}$ square feet
- C $120\frac{1}{3}$ square feet
- D $129\frac{1}{6}$ square feet
- 12 Trisha bought a carton of orange juice. She drank $\frac{1}{3}$ of the carton on Monday and $\frac{5}{12}$ of the carton on Tuesday. What fraction of the carton did Trisha drink?
- A $\frac{1}{2}$
- B $\frac{2}{3}$
- C $\frac{3}{4}$
- D $\frac{5}{6}$



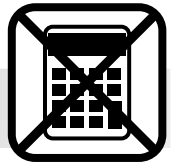

- 13 Three friends equally share $\frac{1}{2}$ of a pizza. How much of the pizza does each friend get?
- A $\frac{1}{6}$
- B $\frac{1}{5}$
- C $\frac{5}{1}$
- D $\frac{6}{1}$
- 14 Mia wants to buy 3 notebooks for \$1.29 each. Which expression shows how to find the total cost?
- A $3 - 1.29$
- B 3×1.29
- C $3 \div 1.29$
- D $3 + 1.29$
- 15 What is the value of $\frac{1}{6} + \frac{1}{12} + \frac{2}{6}$?
- A $\frac{4}{12}$
- B $\frac{6}{12}$
- C $\frac{7}{12}$
- D $\frac{8}{12}$

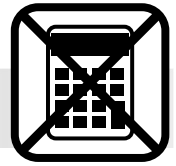

Questions 16 through 20 require you to write your answers in the boxes provided on your answer sheet. A sample grid is shown below each question, but your answer must be properly entered on the answer sheet to be scored. Write only one number or symbol in each box and fill in the circle in each column that matches what you have printed. Fill in only one circle in each column.

- 16 A business has 384 cases of water. There are 42 bottles of water in each case. How many bottles of water does the business have?

Only 0, 1, 2, 3, 4, 5, 6, 7, 8, 9, ., and / are allowed in your answer. Answers that are mixed numbers must be entered as an improper fraction or decimal.

--	--	--	--	--	--

- 17 A rope that is 6 meters long will be cut into 24 pieces that are all of the same length. What will be the length of each piece, in centimeters?

(Note: 100 centimeters = 1 meter)

Only 0, 1, 2, 3, 4, 5, 6, 7, 8, 9, ., and / are allowed in your answer. Answers that are mixed numbers must be entered as an improper fraction or decimal.

--	--	--	--	--	--

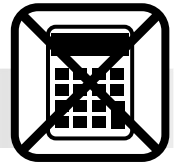

- 18 Wayne exercised for $\frac{5}{6}$ of an hour in the morning and $\frac{1}{3}$ of an hour in the evening. How much more of an hour did Wayne spend exercising in the morning than in the evening?

Only 0, 1, 2, 3, 4, 5, 6, 7, 8, 9, ., and / are allowed in your answer. Answers that are mixed numbers must be entered as an improper fraction or decimal.

--	--	--	--	--	--

- 19 What is the area of the square, in square units?

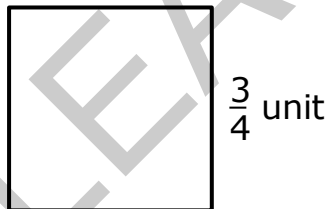

Only 0, 1, 2, 3, 4, 5, 6, 7, 8, 9, ., and / are allowed in your answer. Answers that are mixed numbers must be entered as an improper fraction or decimal.

--	--	--	--	--	--

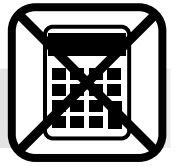

- 20 A factory delivered 284 boxes of books to stores. There are 20 books in each box. How many books did the factory deliver?

Only 0, 1, 2, 3, 4, 5, 6, 7, 8, 9, ., and / are allowed in your answer. Answers that are mixed numbers must be entered as an improper fraction or decimal.

--	--	--	--	--	--

RELEASED



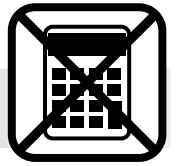

This is the end of the calculator inactive test questions.

Directions:

- 1. Look back over your answers for the calculator inactive questions. You will not be able to go back and work on these questions once you are given a calculator.**
- 2. Raise your hand to let your teacher know you are ready to begin the calculator active test questions.**
- 3. Do not begin work on the calculator active test questions until your teacher has given you a calculator.**

RELEASED



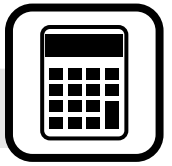

Questions 21 through 25 require you to write your answers in the boxes provided on your answer sheet. A sample grid is shown below each question, but your answer must be properly entered on the answer sheet to be scored. Write only one number or symbol in each box and fill in the circle in each column that matches what you have printed. Fill in only one circle in each column.

21 What is the volume of the figure, in cubic centimeters?

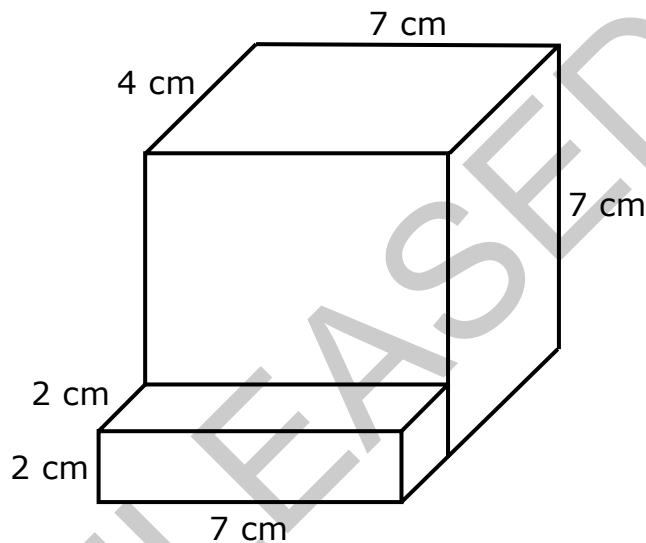

Only 0, 1, 2, 3, 4, 5, 6, 7, 8, 9, ., and / are allowed in your answer. Answers that are mixed numbers must be entered as an improper fraction or decimal.

--	--	--	--	--	--

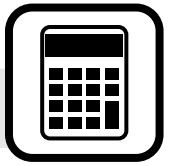

- 22 A school has 45 classrooms. There are 27 students in each classroom. How many students are in all 45 classrooms?

Only 0, 1, 2, 3, 4, 5, 6, 7, 8, 9, ., and / are allowed in your answer. Answers that are mixed numbers must be entered as an improper fraction or decimal.

--	--	--	--	--	--

- 23 Each large square has a value of one.

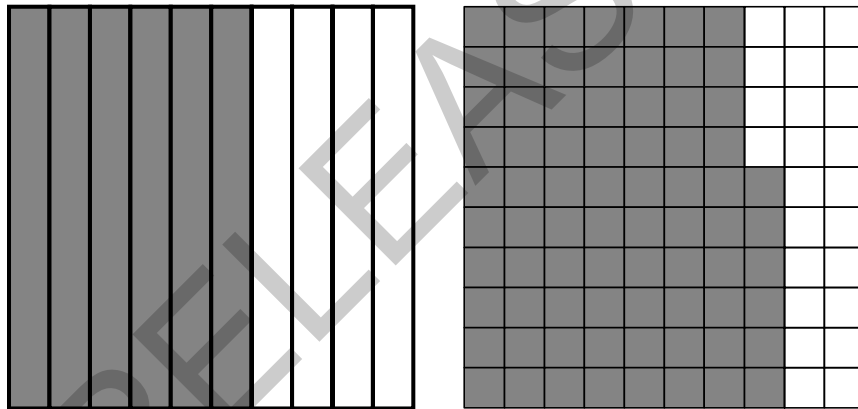

What is the value of the shaded parts of the large squares?

Only 0, 1, 2, 3, 4, 5, 6, 7, 8, 9, ., and / are allowed in your answer. Answers that are mixed numbers must be entered as an improper fraction or decimal.

--	--	--	--	--	--

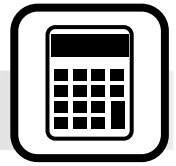

- 24 Eight gardeners equally share $\frac{1}{2}$ of a pile of pine needles. What fraction of the pile does each gardener receive?

Only 0, 1, 2, 3, 4, 5, 6, 7, 8, 9, ., and / are allowed in your answer. Answers that are mixed numbers must be entered as an improper fraction or decimal.

--	--	--	--	--	--

- 25 What is the volume of the rectangular prism, in cubic cm?

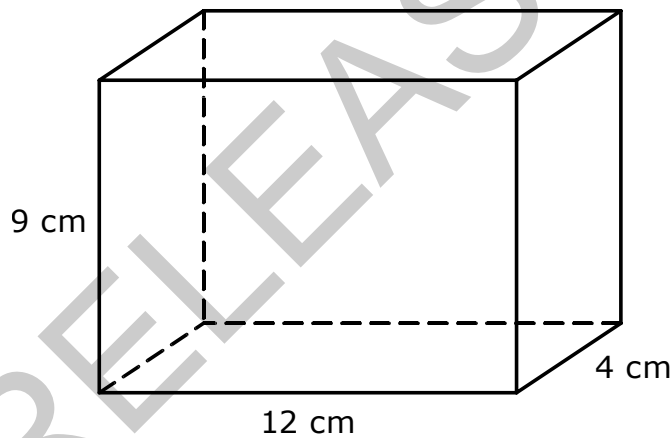

Only 0, 1, 2, 3, 4, 5, 6, 7, 8, 9, ., and / are allowed in your answer. Answers that are mixed numbers must be entered as an improper fraction or decimal.

--	--	--	--	--	--

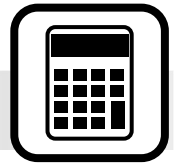

26 Katie will complete a square on the coordinate plane.

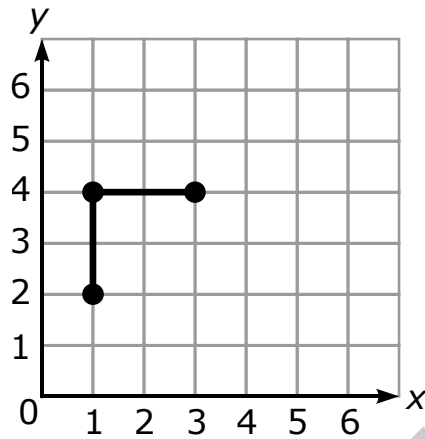

Which coordinate pair will complete this square?

- A (2, 3)
- B (3, 2)
- C (4, 1)
- D (1, 4)

27 The length of a shoe is 25 centimeters. How long is the shoe in meters?

(Note: 1 meter = 100 centimeters)

- A 0.25 meter
- B 2.5 meters
- C 250 meters
- D 2,500 meters

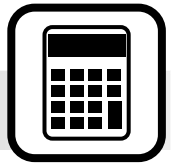

28 The height of a boy, from age 3 to age 8, is shown on the line graph.

Height of a Boy

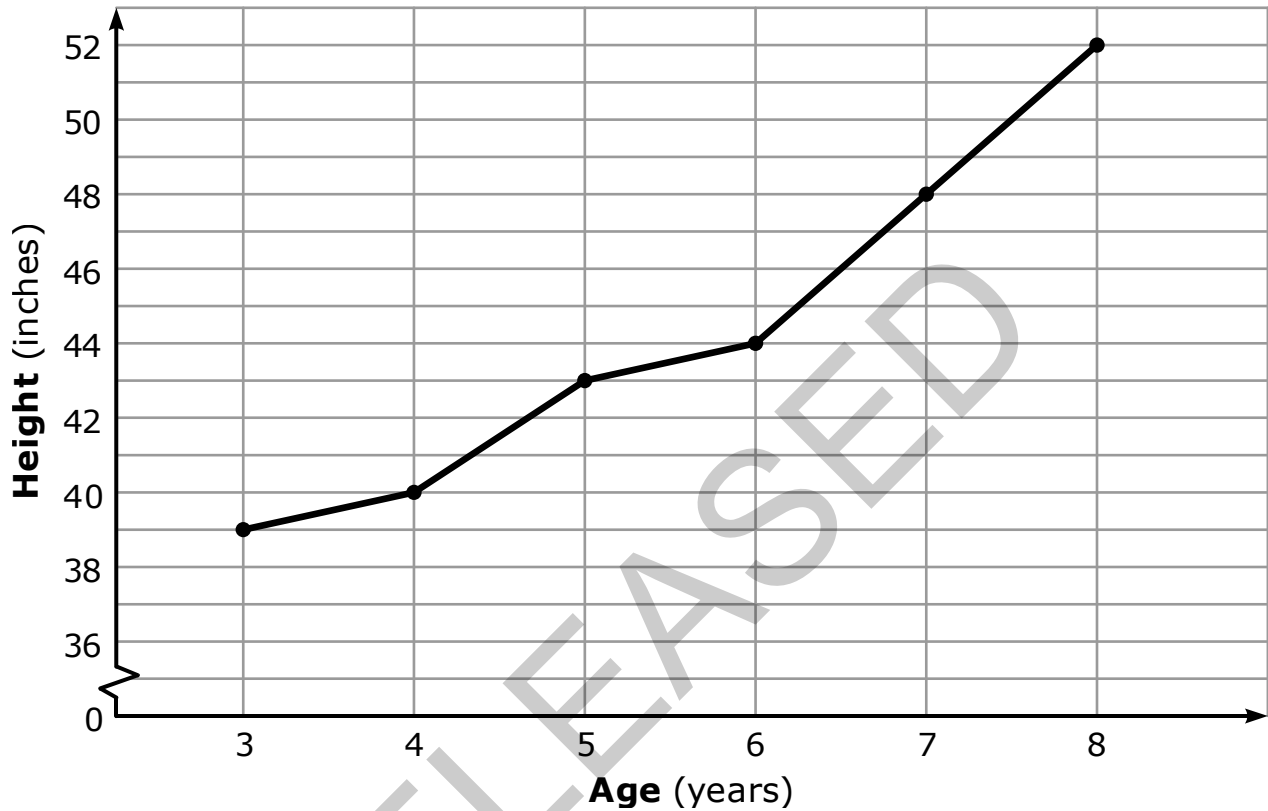

How many inches did the boy grow between 5 and 8 years of age?

- A 8 inches
- B 9 inches
- C 10 inches
- D 11 inches



Go to the next page.

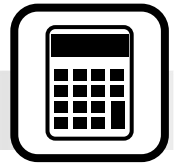

29 Which expression matches the words “eight less than the product of twelve and four”?

- A $8 - (12 \times 4)$
- B $8 - (12 \div 4)$
- C $(12 \times 4) - 8$
- D $(12 \div 4) - 8$

30 Alyssa walked 1.34 fewer miles than Emily. Alyssa walked 2.56 miles. How many miles did Emily walk?

- A 1.22 miles
- B 1.42 miles
- C 3.8 miles
- D 3.9 miles

31 What is the area of the rectangle?

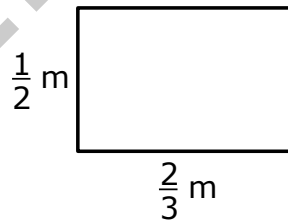

- A $\frac{1}{3}$ square meter
- B $\frac{1}{6}$ square meter
- C $1\frac{1}{6}$ square meters
- D $1\frac{1}{3}$ square meters

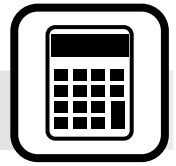

32 Regina has 3 bags of marbles. There are 25 marbles in each bag. She wants to put an equal number of marbles into 5 bags. Which expression would show how many marbles can go in each bag?

- A $3 \div 25 \times 5$
- B $(25 \times 3) \div 5$
- C $(25 \div 3) \times 5$
- D $3 \times 25 \times 5$

33 Lou has two sets of numbers.

- The first set starts with 3 and follows a pattern of increasing by 5.
- The second set starts with 39 and follows a pattern of decreasing by 6.

How many numbers do the two sets have in common?

- A 5
- B 4
- C 3
- D 2

34 Mr. Parker is graphing a quadrilateral. He wants the quadrilateral to be a trapezoid. He has already graphed vertices at $(1, 1)$, $(3, 3)$, and $(5, 3)$. Which choice is a point that could be the 4th vertex?

- A $(1, 3)$
- B $(3, 5)$
- C $(5, 1)$
- D $(5, 5)$

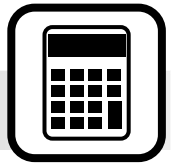

35 Mr. Wilson bought a bag of birdseed and put half of it in his bird feeder. He split the other half equally among his 4 pet birds. How much of the bag did each pet bird get?

A $\frac{1}{8}$ bag

B $\frac{1}{4}$ bag

C $\frac{1}{2}$ bag

D $\frac{3}{4}$ bag

RELEASED

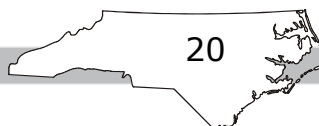

Go to the next page.

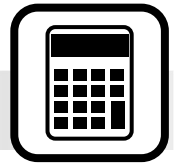

36 The line graph shows the monthly attendance at a fun park for a year.

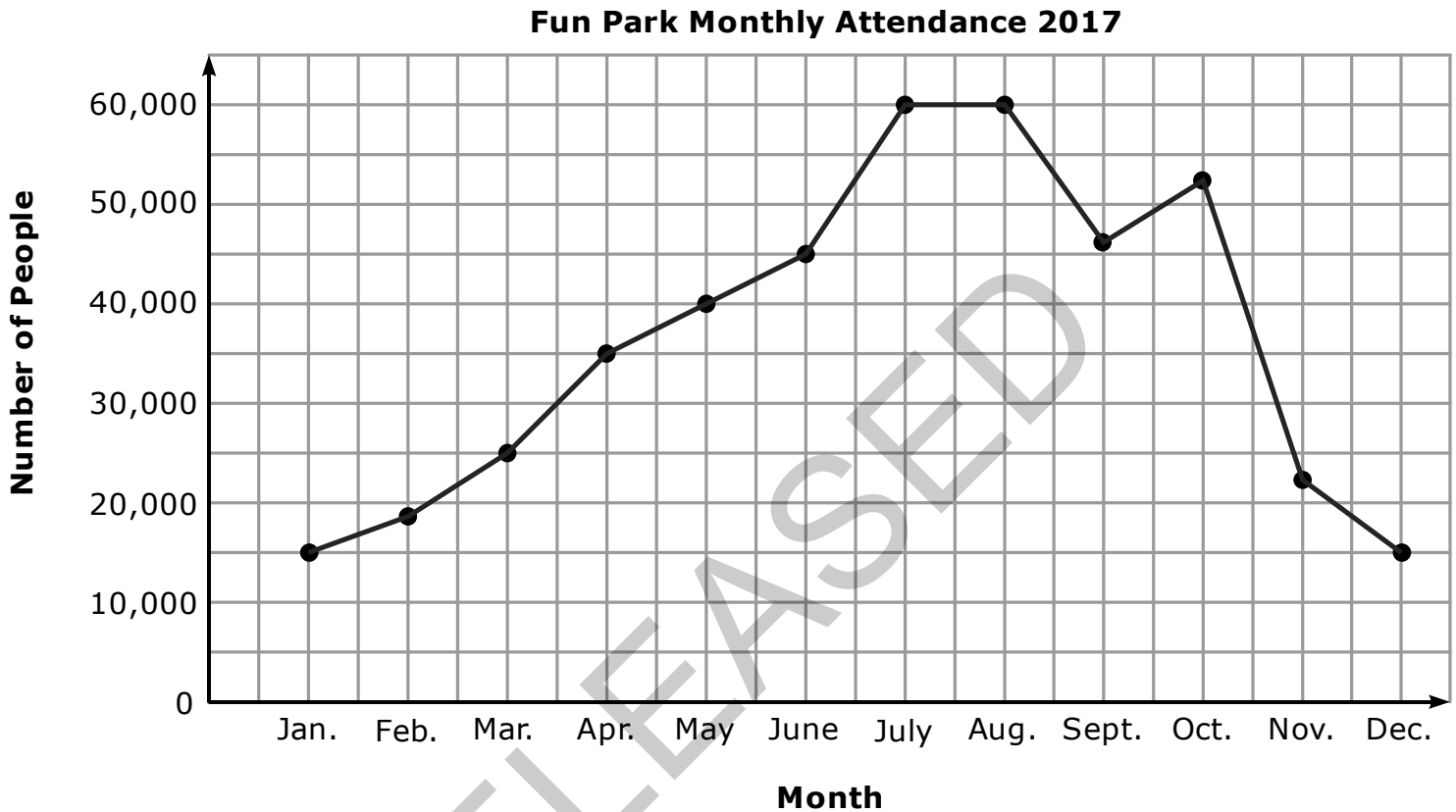

Which statement describes the data on the line graph?

- A The highest attendance was during January and February.
- B The attendance decreased between October and November.
- C The lowest attendance was during September and October.
- D The attendance increased between July and August.



37 Fred bought a shirt and a wallet for a total of \$34.26 before tax. The price of the wallet was \$15 less than the price of the shirt. What was the price of the shirt?

- A \$19.25
- B \$19.83
- C \$24.63
- D \$24.75

38 How many feet are in 2,241 inches?

(Note: 1 foot = 12 inches)

- A 62.25 feet
- B 186.75 feet
- C 189.25 feet
- D 747.00 feet

39 A pattern of ordered pairs is shown.

$(0, 1), (2, 4), (4, 7), (6, 10)$

The pattern continues. What is the ***eighth*** ordered pair in the pattern?

- A $(8, 13)$
- B $(14, 18)$
- C $(14, 22)$
- D $(16, 19)$

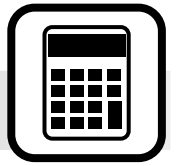

40 Which choice is the expanded form for 602.049?

- A $6 \times 100 + 2 \times 1 + 4 \times \left(\frac{1}{10}\right) + 9 \times \left(\frac{1}{1,000}\right)$
- B $6 \times 100 + 2 \times 10 + 4 \times \left(\frac{1}{10}\right) + 9 \times \left(\frac{1}{100}\right)$
- C $6 \times \left(\frac{1}{100}\right) + 2 \times \left(\frac{1}{1}\right) + 4 \times \left(\frac{1}{100}\right) + 9 \times \left(\frac{1}{1,000}\right)$
- D $6 \times 100 + 2 \times 1 + 4 \times \left(\frac{1}{100}\right) + 9 \times \left(\frac{1}{1,000}\right)$

RELEASED

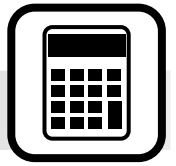

Directions:

This is the end of the mathematics test.

- 1. Put all of your papers inside your test book and close your test book.**
- 2. Place your calculator on top of the test book.**
- 3. Stay quietly in your seat until your teacher tells you that testing is finished.**

RELEASED

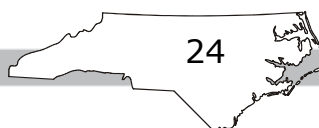

**Grade 5 Mathematics
RELEASED Form
2018–2019
Answer Key**

Item Number	Type	Key	Domain
S1	MC	C	
S2	GR	2.7	
S3	GR	3/4	

Calculator Inactive



Item Number	Type	Key	Domain
1	MC	D	NC.5.NBT.5
2	MC	A	NC.5.NBT.7
3	MC	C	NC.5.NF.3
4	MC	A	NC.5.NF.4
5	MC	D	NC.5.NF.7
6	MC	B	NC.5.NF.1
7	MC	A	NC.5.NBT.6
8	MC	C	NC.5.NF.3
9	MC	A	NC.5.NF.1
10	MC	B	NC.5.NF.3
11	MC	D	NC.5.NF.4
12	MC	C	NC.5.NF.1
13	MC	A	NC.5.NF.7
14	MC	B	NC.5.OA.2
15	MC	C	NC.5.NF.1
16	GR	16128	NC.5.NBT.5
17	GR	25	NC.5.NBT.6

GRADE 5 MATHEMATICS — RELEASED FORM

Item Number	Type	Key	Domain
18	GR	1/2	NC.5.NF.1
19	GR	9/16	NC.5.NF.4
20	GR	5680	NC.5.NBT.5

Calculator Active



Item Number	Type	Key	Domain
21	GR	224	NC.5.MD.5
22	GR	1215	NC.5.NBT.5
23	GR	1.36	NC.5.NBT.7
24	GR	1/16	NC.5.NF.7
25	GR	432	NC.5.MD.5
26	MC	B	NC.5.G.1
27	MC	A	NC.5.MD.1
28	MC	B	NC.5.MD.2
29	MC	C	NC.5.OA.2
30	MC	D	NC.5.NBT.7
31	MC	A	NC.5.NF.4
32	MC	B	NC.5.OA.2
33	MC	D	NC.5.OA.3
34	MC	C	NC.5.G.3
35	MC	A	NC.5.NF.7
36	MC	B	NC.5.MD.2
37	MC	C	NC.5.NBT.7
38	MC	B	NC.5.MD.1
39	MC	C	NC.5.OA.3
40	MC	D	NC.5.NBT.3