



AP[®] Physics B Practice Exam

From the 2012 Administration

This Practice Exam from the 2012 international administration is provided by the College Board for AP Exam preparation. Teachers are permitted to download the materials and make copies to use with their students in a classroom setting only. To maintain the security of this exam, teachers should collect all materials after their administration and keep them in a secure location.

Exams may **not** be posted on school or personal websites, nor electronically redistributed for any reason. Further distribution of these materials outside of the secure College Board site disadvantages teachers who rely on uncirculated questions for classroom testing. Any additional distribution is in violation of the College Board's copyright policies and may result in the termination of Practice Exam access for your school as well as the removal of access to other online services such as the AP Teacher Community and Online Score Reports.

Contents

Exam Instructions

Student Answer Sheet for the Multiple-Choice Section

Section I: Multiple-Choice Questions

Section II: Free-Response Questions

Multiple-Choice Answer Key

Free-Response Scoring Guidelines

Scoring Worksheet

Note: This publication shows the page numbers that appeared in the *2011–12 AP Exam Instructions* book and in the actual exam. This publication was not repaginated to begin with page 1.

Exam Instructions

The following contains instructions taken from
the *2011–12 AP Exam Instructions* book.

AP[®] Physics B Exam

Regularly Scheduled Exam Date: Monday afternoon, May 14, 2012

Late-Testing Exam Date: Friday morning, May 25, 2012

Section I: At a Glance

Total Time:

1 hour, 30 minutes

Number of Questions:

70*

Percent of Total Score:

50%

Writing Instrument:

Pencil required

Electronic Device:

None allowed

Section II: At a Glance

Total Time:

1 hour, 30 minutes

Number of Questions:

7*

Percent of Total Score:

50%

Writing Instrument:

Either pencil or pen with black or dark blue ink

Electronic Device:

Calculator allowed

Percent of Section II Score:

See breakdown on test book cover

Section I: Multiple Choice Booklet Instructions

Section I of this exam contains 70* multiple-choice questions. Fill in only the circles for numbers 1 through 70 on your answer sheet. A table of information that may be helpful is in the booklet. Rulers and straightedges may be used in this section.

Indicate all of your answers to the multiple-choice questions on the answer sheet. No credit will be given for anything written in this exam booklet, but you may use the booklet for notes or scratch work. After you have decided which of the suggested answers is best, completely fill in the corresponding circle on the answer sheet. Give only one answer to each question. If you change an answer, be sure that the previous mark is erased completely.

Use your time effectively, working as quickly as you can without losing accuracy. Do not spend too much time on any one question. Go on to other questions and come back to the ones you have not answered if you have time. It is not expected that everyone will know the answers to all of the multiple-choice questions.

Your total score on the multiple-choice section is based only on the number of questions answered correctly. Points are not deducted for incorrect answers or unanswered questions.

**The number of questions may vary slightly depending on the form of the exam.*

Section II: Free Response Booklet Instructions

The questions for Section II are printed in this booklet. You may use any blank space in the booklet for scratch work, but you must write your answers in the spaces provided for each answer. A table of information and lists of equations that may be helpful are in the booklet. Calculators, rulers, and straightedges may be used in this section.

All final numerical answers should include appropriate units. Credit for your work depends on demonstrating that you know which physical principles would be appropriate to apply in a particular situation. Therefore, you should show your work for each part in the space provided after that part. If you need more space, be sure to clearly indicate where you continue your work. Credit will be awarded only for work that is clearly designated as the solution to a specific part of a question. Credit also depends on the quality of your solutions and explanations, so you should show your work.

Write clearly and legibly. Cross out any errors you make; erased or crossed-out work will not be scored. You may lose credit for incorrect work that is not crossed out.

Manage your time carefully. You may proceed freely from one question to the next. You may review your responses if you finish before the end of the exam is announced.

**The number of questions may vary slightly depending on the form of the exam.*

What Proctors Need to Bring to This Exam

- Exam packets
- Answer sheets
- AP Student Packs
- *2011-12 AP Coordinator’s Manual*
- This book — *AP Exam Instructions*
- School Code and Home-School/Self-Study Codes
- Extra calculators
- Extra rulers or straightedges
- Pencil sharpener
- Extra No. 2 pencils with erasers
- Extra pens with black or dark blue ink
- Extra paper
- Stapler
- Watch
- Signs for the door to the testing room
 - “Exam in Progress”
 - “Cell phones are prohibited in the testing room”

Students are permitted to use four-function, scientific, programmable, or graphing calculators on parts of this exam. Review the section “Calculator Policy” on pages 40–42 of the *2011-12 AP Coordinator’s Manual*. Before starting the exam administration, make sure each student has an appropriate calculator, and any student with a graphing calculator has a model from the approved list on page 42 of the *2011-12 AP Coordinator’s Manual*. If a student does not have a calculator or has a graphing calculator not on the approved list, you may provide one from your supply. If the student does not want to use the calculator you provide or does not want to use a calculator at all, he or she must hand copy, date, and sign the release statement on page 41 of the *2011-12 AP Coordinator’s Manual*. Rulers and straightedges may be used for the entire exam. Since graphing calculators can be used to store data, including text, proctors should monitor that students are using their calculators appropriately. Attempts by students to use the calculator to remove exam questions and/or answers from the room may result in the cancellation of AP Exam scores.

SECTION I: Multiple Choice

- **Do not begin the exam instructions below until you have completed the appropriate**
- **General Instructions for your group.**

This exam includes survey questions. The time allowed for the survey questions is in addition to the actual test-taking time.

Make sure you begin the exam at the designated time.

If you are giving the regularly scheduled exam, say:

It is Monday afternoon, May 14, and you will be taking the AP Physics B Exam.

If you are giving the alternate exam for late testing, say:

It is Friday morning, May 25, and you will be taking the AP Physics B Exam.

In a moment, you will open the packet that contains your exam materials. By opening this packet, you agree to all of the AP Program's policies and procedures outlined in the *2011-12 Bulletin for AP Students and Parents*. You may now remove the shrinkwrap from your exam packet and take out the Section I booklet, but do not open the booklet or the shrinkwrapped Section II materials. Put the white seals aside. . . .

Look at page 1 of your answer sheet and locate the dark blue box near the top right-hand corner that states, "Take the AP Exam label from your Section I booklet and place the label here." . . .

Now look at the front cover of your exam booklet and locate the AP Exam label near the top left of the cover. . . .

Carefully peel off the AP Exam label and place it on your answer sheet on the dark blue box that we just identified. . . .

Now read the statements on the front cover of Section I and look up when you have finished. . . .

Sign your name and write today's date. Look up when you have finished. . . .

Now print your full legal name where indicated. Are there any questions? . . .

Turn to the back cover and read it completely. Look up when you have finished. . . .

Are there any questions? . . .

Section I is the multiple-choice portion of the exam. You may never discuss these specific multiple-choice questions at any time in any form with anyone, including your teacher and other students. If you disclose these questions through any means, your AP Exam score will be canceled. Are there any questions? . . .

You must complete the answer sheet using a No. 2 pencil only. Mark all of your responses on your answer sheet, one response per question. Completely fill in the circles. If you need to erase, do so carefully and completely. No credit will be given for anything written in the exam booklet. Scratch paper is not allowed, but you may use the margins or any blank space in the exam booklet for scratch work. Rulers and straightedges may be used for the entire exam, but calculators are not allowed for Section I of the exam. Please put all of your calculators under your chair. Are there any questions? . . .

You have 1 hour and 30 minutes for this section. Open your Section I booklet and begin.



Note Start Time here _____. Note Stop Time here _____. Check that students are marking their answers in pencil on their answer sheets, and that they are not looking at their shrinkwrapped Section II booklets. After 1 hour and 30 minutes, say:

Stop working and turn to the last page of your booklet. . . .

You have 2 minutes to answer Questions 101–106. These are survey questions and will not affect your score. You may not go back to work on any of the exam questions. You may now begin.

To help you and your proctors make sure students are not working on the exam questions, the two pages with the survey questions are identified with a large S on the upper corner of each page. Give students 2 minutes to answer the survey questions. Then say:

Close your booklet and put your answer sheet on your desk, face up. Make sure you have your AP number label and an AP Exam label on page 1 of your answer sheet. I will now collect your answer sheet.

Collect an answer sheet from each student. Check that each answer sheet has an AP number label and an AP Exam label. Then say:

Now you must seal your exam booklet. Remove the white seals from the backing and press one on each area of your exam booklet cover marked “PLACE SEAL HERE.” Fold each seal over the back cover. When you have finished, place the booklet on your desk, face up. I will now collect your Section I booklet. . . .

Check that each student has signed the front cover of the sealed Section I booklet. There is a 10-minute break between Sections I and II. When all Section I materials have been collected and accounted for and you are ready for the break, say:

Please listen carefully to these instructions before we take a 10-minute break. Everything you placed under your chair at the beginning of the exam must stay there. Leave your shrinkwrapped Section II packet on your desk during the break. You are not allowed to consult teachers, other students, or textbooks about the exam during the break. You may not make phone calls, send text messages, check email, use a social networking site, or access any electronic or communication device. Remember, you are not allowed to discuss the multiple-choice section of this exam. Failure to adhere to any of these rules could result in cancellation of your score. Are there any questions? . . .



You may begin your break. Testing will resume at _____.

SECTION II: Free Response

After the break, say:

May I have everyone’s attention? Place your Student Pack on your desk. . . .

You may now remove the shrinkwrap from the Section II packet, but do not open the exam booklet until you are told to do so. . . .

Read the bulleted statements on the front cover of the exam booklet. Look up when you have finished. . . .

Now place an AP number label on the shaded box. If you don’t have any AP number labels, write your AP number in the box. Look up when you have finished. . . .

Read the last statement. . . .

Using your pen, print the first, middle and last initials of your legal name in the boxes and print today's date where indicated. This constitutes your signature and your agreement to the statements on the front cover. . . .

Turn to the back cover and read Item 1 under "Important Identification Information." Print the first two letters of your last name and the first letter of your first name in the boxes. Look up when you have finished. . . .

In Item 2, print your date of birth in the boxes. . . .

In Item 3, write the school code you printed on the front of your Student Pack in the boxes. . . .

Read Item 4. . . .

Are there any questions? . . .

I need to collect the Student Pack from anyone who will be taking another AP Exam. You may keep it only if you are not taking any other AP Exams this year. If you have no other AP Exams to take, place your Student Pack under your chair now. . . .

While Student Packs are being collected, read the information on the back cover of the exam booklet. Do not open the booklet until you are told to do so. Look up when you have finished. . . .

Collect the Student Packs. Then say:

Are there any questions? . . .

Calculators may be used for Section II. You may get your calculators from under your chair and place them on your desk. . . .

You have 1 hour and 30 minutes to complete Section II. You are responsible for pacing yourself, and you may proceed freely from one question to the next. You must write your answers in the exam booklet using a pen or a No. 2 pencil. If you use a pencil, be sure that your writing is dark enough to be easily read. If you need more paper during the exam, raise your hand. At the top of each extra piece of paper you use, be sure to write only your AP number and the number of the question you are working on. Do not write your name. Are there any questions? . . .

You may begin.



Note Start Time here _____. Note Stop Time here _____. Check that students are writing their answers in their exam booklets. You should also make sure that calculators' infrared ports are not facing each other. After 1 hour and 20 minutes, say:

There are 10 minutes remaining.

After 10 minutes, say:

Stop working and close your exam booklet. Place it on your desk, face up. . . .

If any students used extra paper for the free-response section, have those students staple the extra sheet/s to the first page corresponding to that question in their exam booklets. Then say:

Remain in your seat, without talking, while the exam materials are collected. . . .

Collect a Section II booklet from each student. Check for the following:

- Exam booklet front cover: The student placed an AP number label on the shaded box, and printed his or her initials and today's date.
- Exam booklet back cover: The student completed the "Important Identification Information" area.

When all exam materials have been collected and accounted for, return to students any electronic devices you may have collected before the start of the exam.

If you are giving the regularly scheduled exam, say:

You may not discuss these specific free-response questions with anyone unless they are released on the College Board website in about two days. You should receive your score report in the mail about the third week of July.

If you are giving the alternate exam for late testing, say:

None of the questions in this exam may ever be discussed or shared in any way at any time. You should receive your score report in the mail about the third week of July.

If any students completed the AP number card at the beginning of this exam, say:

Please remember to take your AP number card with you.

Then say:

You are now dismissed.

All exam materials should be put in secure storage until they are returned to the AP Program after your school's last administration. Before storing materials, check the "School Use Only" section on page 1 of the answer sheet and:

- Fill in the appropriate section number circle in order to view a separate AP Instructional Planning Report (for regularly scheduled exams only) or Subject Score Roster at the class section or teacher level. See "Post-Exam Activities" in the *2011-12 AP Coordinator's Manual*.
- Check your list of students who are eligible for fee reductions and fill in the appropriate circle on their registration answer sheets.

GO ON TO THE NEXT PAGE.

Student Answer Sheet for the Multiple-Choice Section

Use this section to capture student responses. (Note that the following answer sheet is a sample, and may differ from one used in an actual exam.)



Take the AP Exam label from your Section I booklet and place the label here.



B123456789T

Take an AP Number label from your AP Student Pack and place the label here.

NAME AND EXAM AREA — COMPLETE THIS AREA AT EVERY EXAM.

To maintain the security of the exam and the validity of my AP score, I will allow no one else to see the multiple-choice questions. I will seal the multiple-choice booklet when asked to do so, and I will not discuss these questions with anyone at any time after the completion of the section. I am aware of and agree to the AP Program's policies and procedures as outlined in the *2011-12 Bulletin for AP Students and Parents*, including using testing accommodations (e.g., extended time, computer, etc.) only if I have been preapproved by College Board Services for Students with Disabilities.

A. SIGNATURE _____ Sign your legal name as it will appear on your college applications. _____ Date _____

B. LEGAL NAME		Legal First Name — First 12 Letters												MI
Legal Last Name — First 15 Letters A B C D E F G H I J K L M N O P Q R S T U V W X Y Z														

SCHOOL USE ONLY

Section Number	1	2	3	4	5	6	7	8	9
Fee Reduction Granted	Option 1		Option 2			Option 3		Option 4	

ETS USE ONLY

Exam	0	1	2	3	4	5	6	7	8	9
Exam	0	1	2	3	4	5	6	7	8	9

762000
762000

USE NO. 2 PENCIL ONLY

C. YOUR AP NUMBER

--	--	--	--	--	--	--	--	--	--	--	--	--	--	--	--	--	--	--	--	--	--	--	--	--	--	--	--	--

D. EXAM DATE

Month													
Day													
Year													

E. EXAM START TIME

AM					
PM					

F. MULTIPLE-CHOICE BOOKLET SERIAL NUMBER

S																												
---	--	--	--	--	--	--	--	--	--	--	--	--	--	--	--	--	--	--	--	--	--	--	--	--	--	--	--	--

G. ONLINE PROVIDER CODE

--	--	--	--	--	--	--	--	--	--	--	--	--	--	--	--	--	--	--	--	--	--	--	--	--	--	--	--	--	--

Print Exam Name: _____

Print Form Code: _____

STUDENT INFORMATION AREA — COMPLETE THIS AREA ONLY ONCE.

I. DATE OF BIRTH	Month																											
	Day																											
	Year																											

J. SEX
 Female
 Male

K. CURRENT GRADE LEVEL
 Pre-9th
 9th
 10th
 11th
 12th
 Post-12th

L. SOCIAL SECURITY NUMBER (Optional)

--	--	--	--	--	--	--	--	--	--	--	--	--	--	--	--	--	--	--	--	--	--	--	--	--	--	--	--	--	--

M. EXPECTED DATE OF COLLEGE ENTRANCE
 Fall
 Winter/Spring
 Summer
 Undecided

N. STUDENT SEARCH SERVICE®
 I want the College Board to send information about me to colleges, universities and government scholarship programs interested in students like me.
 Yes
 No

O. WHICH LANGUAGE DO YOU KNOW BEST?

English

English and another language about the same

Another language

P. ETHNICITY/RACE

American Indian or Alaska Native

Asian, Asian American or Pacific Islander

Black or African American

Mexican or Mexican American

Puerto Rican

Other Hispanic, Latino or Latin American

White

Other

Q. PARENTAL EDUCATION LEVEL

Father/Male Guardian: Graduate school Some high school High school diploma or equivalent Business or trade school Some college Associate or two-year degree Bachelor's or four-year degree Some graduate or professional school Graduate or professional degree

Mother/Female Guardian: Graduate school Some high school High school diploma or equivalent Business or trade school Some college Associate or two-year degree Bachelor's or four-year degree Some graduate or professional school Graduate or professional degree

HOME ADDRESS AND SCHOOL AREA — COMPLETE THIS AREA ONLY ONCE.

T. YOUR MAILING ADDRESS Use the address abbreviations from your AP Student Pack. Fill in only one circle per column. Indicate a space in your address by leaving a blank box; do not grid that column.

STREET ADDRESS (include street number, street name, apartment number, etc.)

A	A	A	A	A	A	A	A	A	A	A	A	A	A	A	A	A	A	A	A	A	A	A	A	CITY	ZIP OR POSTAL CODE	COUNTRY CODE		

U. AREA CODE AND PHONE NUMBER

INTERNATIONAL PHONE

V. SCHOOL YOU ATTEND

SCHOOL CODE	School Name	City	State	Country

W. COLLEGE TO RECEIVE YOUR AP SCORE REPORT

Using the college code listed in the AP Student Pack, indicate the **ONE** college that you want to receive your AP score report.

COLLEGE CODE	College Name	City	State	Country

STATE		Country	
<input type="radio"/> AK	<input type="radio"/> HI	<input type="radio"/> MI	<input type="radio"/> UT
<input type="radio"/> AL	<input type="radio"/> IA	<input type="radio"/> MN	<input type="radio"/> VA
<input type="radio"/> AR	<input type="radio"/> ID	<input type="radio"/> MO	<input type="radio"/> VT
<input type="radio"/> AZ	<input type="radio"/> IL	<input type="radio"/> MS	<input type="radio"/> WA
<input type="radio"/> CA	<input type="radio"/> IN	<input type="radio"/> MT	<input type="radio"/> WI
<input type="radio"/> CO	<input type="radio"/> KS	<input type="radio"/> NC	<input type="radio"/> WV
<input type="radio"/> CT	<input type="radio"/> KY	<input type="radio"/> ND	<input type="radio"/> WY
<input type="radio"/> DC	<input type="radio"/> LA	<input type="radio"/> NE	<input type="radio"/> Puerto Rico
<input type="radio"/> DE	<input type="radio"/> MA	<input type="radio"/> NH	<input type="radio"/> SD
<input type="radio"/> FL	<input type="radio"/> MD	<input type="radio"/> NJ	<input type="radio"/> TN
<input type="radio"/> GA	<input type="radio"/> ME	<input type="radio"/> NM	<input type="radio"/> TX

X. FOR STUDENTS OUTSIDE THE UNITED STATES ONLY
If the address gridded above is not complete enough for delivery of your score report, please fill in this circle and print your complete address below.

Address: _____ City: _____ State or Province: _____ Country: _____ ZIP or Postal Code: _____

Y. EMAIL ADDRESS

By providing your email address, you are granting the College Board permission to use your email in accordance with the policies in the 2017-12 Bulletin for AP Students and Parents.

GO ON TO THE NEXT PAGE.

Section I: Multiple-Choice Questions

This is the multiple-choice section of the 2012 AP exam. It includes cover material and other administrative instructions to help familiarize students with the mechanics of the exam. (Note that future exams may differ in look from the following content.)

PLACE SEAL HERE

AP[®] Physics B Exam

SECTION I: Multiple Choice

2012

DO NOT OPEN THIS BOOKLET UNTIL YOU ARE TOLD TO DO SO.

At a Glance

Total Time

1 hour, 30 minutes

Number of Questions

70

Percent of Total Score

50%

Writing Instrument

Pencil required

Electronic Device

None allowed

Instructions

Section I of this exam contains 70 multiple-choice questions. Fill in only the circles for numbers 1 through 70 on your answer sheet. A table of information that may be helpful is in the booklet. Rulers and straightedges may be used in this section.

Indicate all of your answers to the multiple-choice questions on the answer sheet. No credit will be given for anything written in this exam booklet, but you may use the booklet for notes or scratch work. After you have decided which of the suggested answers is best, completely fill in the corresponding circle on the answer sheet. Give only one answer to each question. If you change an answer, be sure that the previous mark is erased completely. Here is a sample question and answer.

Sample Question Sample Answer

Chicago is a (A) ● (C) (D) (E)
(A) state
(B) city
(C) country
(D) continent
(E) village

Use your time effectively, working as quickly as you can without losing accuracy. Do not spend too much time on any one question. Go on to other questions and come back to the ones you have not answered if you have time. It is not expected that everyone will know the answers to all of the multiple-choice questions.

Your total score on the multiple-choice section is based only on the number of questions answered correctly. Points are not deducted for incorrect answers or unanswered questions.

PLACE SEAL HERE



Minimum 20% post-consumer waste

PLACE SEAL HERE

DO NOT seal answer sheet inside

Form I
Form Code 4IBP4-S

78

TABLE OF INFORMATION DEVELOPED FOR 2012

CONSTANTS AND CONVERSION FACTORS	
Proton mass, $m_p = 1.67 \times 10^{-27}$ kg Neutron mass, $m_n = 1.67 \times 10^{-27}$ kg Electron mass, $m_e = 9.11 \times 10^{-31}$ kg Avogadro's number, $N_0 = 6.02 \times 10^{23}$ mol ⁻¹ Universal gas constant, $R = 8.31$ J/(mol·K) Boltzmann's constant, $k_B = 1.38 \times 10^{-23}$ J/K	Electron charge magnitude, $e = 1.60 \times 10^{-19}$ C 1 electron volt, $1 \text{ eV} = 1.60 \times 10^{-19}$ J Speed of light, $c = 3.00 \times 10^8$ m/s Universal gravitational constant, $G = 6.67 \times 10^{-11}$ m ³ /kg·s ² Acceleration due to gravity at Earth's surface, $g = 9.8$ m/s ²
1 unified atomic mass unit, Planck's constant, Vacuum permittivity, Coulomb's law constant, $k = 1/4\pi\epsilon_0 = 9.0 \times 10^9$ N·m ² /C ² Vacuum permeability, Magnetic constant, $k' = \mu_0/4\pi = 1 \times 10^{-7}$ (T·m)/A 1 atmosphere pressure,	$1 \text{ u} = 1.66 \times 10^{-27}$ kg = 931 MeV/c ² $h = 6.63 \times 10^{-34}$ J·s = 4.14×10^{-15} eV·s $hc = 1.99 \times 10^{-25}$ J·m = 1.24×10^3 eV·nm $\epsilon_0 = 8.85 \times 10^{-12}$ C ² /N·m ² $\mu_0 = 4\pi \times 10^{-7}$ (T·m)/A $1 \text{ atm} = 1.0 \times 10^5$ N/m ² = 1.0×10^5 Pa

UNIT SYMBOLS	meter, m	kilogram, kg	second, s	ampere, A	kelvin, K	mole, mol	hertz, Hz	newton, N	pascal, Pa	joule, J	watt, W	coulomb, C	volt, V	ohm, Ω	henry, H	farad, F	tesla, T	degree Celsius, °C	electron-volt, eV
--------------	----------	--------------	-----------	-----------	-----------	-----------	-----------	-----------	------------	----------	---------	------------	---------	--------	----------	----------	----------	--------------------	-------------------

PREFIXES		
Factor	Prefix	Symbol
10 ⁹	giga	G
10 ⁶	mega	M
10 ³	kilo	k
10 ⁻²	centi	c
10 ⁻³	milli	m
10 ⁻⁶	micro	μ
10 ⁻⁹	nano	n
10 ⁻¹²	pico	p

VALUES OF TRIGONOMETRIC FUNCTIONS FOR COMMON ANGLES							
θ	0°	30°	37°	45°	53°	60°	90°
$\sin \theta$	0	1/2	3/5	$\sqrt{2}/2$	4/5	$\sqrt{3}/2$	1
$\cos \theta$	1	$\sqrt{3}/2$	4/5	$\sqrt{2}/2$	3/5	1/2	0
$\tan \theta$	0	$\sqrt{3}/3$	3/4	1	4/3	$\sqrt{3}$	∞

The following conventions are used in this exam.

- I. Unless otherwise stated, the frame of reference of any problem is assumed to be inertial.
- II. The direction of any electric current is the direction of flow of positive charge (conventional current).
- III. For any isolated electric charge, the electric potential is defined as zero at an infinite distance from the charge.
- IV. For mechanics and thermodynamics equations, W represents the work done on a system.

PHYSICS B
SECTION I
Time—90 minutes
70 Questions

Directions: Each of the questions or incomplete statements below is followed by five suggested answers or completions. Select the one that is best in each case and then fill in the corresponding circle on the answer sheet.

Note: To simplify calculations, you may use $g = 10 \text{ m/s}^2$ in all problems.

1. Which of the following terms best refers to the tendency of a mass to resist a change in its velocity?

- (A) Acceleration
- (B) Friction
- (C) Normal force
- (D) Gravitational force
- (E) Inertia

2. What is the ratio of the kinetic energy of an object of mass $3m$ moving at speed $2v$ to an object of mass $m/2$ moving at a speed v ?

- (A) 2
- (B) 3
- (C) 6
- (D) 12
- (E) 24



3. A uniform meterstick is balanced at the center, as shown above. Which of the following shows how a 0.50 kg mass and a 1.0 kg mass could be hung on the meterstick so that the stick stays balanced?

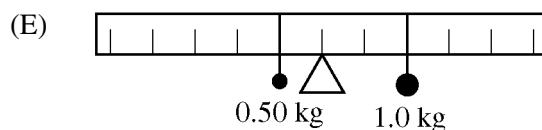
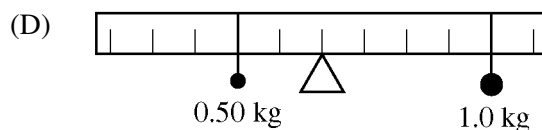
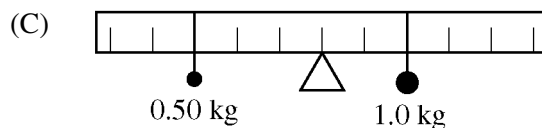
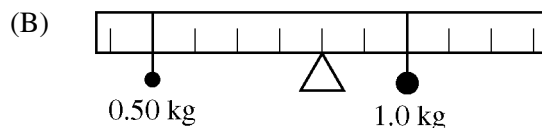
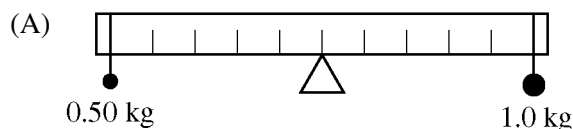

4. An artificial satellite orbits Earth at a speed of 7800 m/s and a height of 200 km above Earth's surface. The satellite experiences an acceleration due to gravity of

- (A) 39 m/s^2
 (B) less than 39 m/s^2 but greater than 9.8 m/s^2
 (C) 9.8 m/s^2
 (D) less than 9.8 m/s^2 but greater than zero
 (E) zero

5. A car goes from rest to 30 m/s in 12 s with constant acceleration. How long does it take the car to go from rest to 15 m/s with the same acceleration?

- (A) 3.0 s
 (B) $12/\sqrt{2}$ s
 (C) 6.0 s
 (D) $12\sqrt{2}$ s
 (E) 24 s

6. A simple pendulum is used to determine the acceleration due to gravity at the surface of a planet. The pendulum has a length of 2 m and its period is measured to be 2 s. The value of g obtained in this investigation is most nearly

- (A) 1 m/s^2
 (B) 2 m/s^2
 (C) 5 m/s^2
 (D) 10 m/s^2
 (E) 20 m/s^2

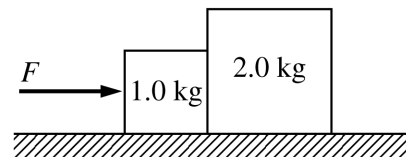

7. Two blocks of masses 1.0 kg and 2.0 kg, respectively, are pushed by a constant applied force F across a horizontal frictionless table with constant acceleration such that the blocks remain in contact with each other, as shown above. The 1.0 kg block pushes the 2.0 kg block with a force of 2.0 N. The acceleration of the two blocks is

- (A) 0
 (B) 1.0 m/s^2
 (C) 1.5 m/s^2
 (D) 2.0 m/s^2
 (E) 3.0 m/s^2

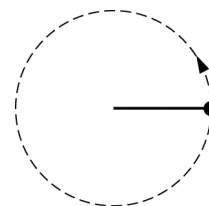

Side View

8. A rock attached to a string swings in a vertical circle, as shown above, with negligible air resistance. Which of the following diagrams could correctly show all the forces on the rock when the string is in the position above?

- (A)
- (B)
- (C)
- (D)
- (E)

9. Which of the following is constant for an object in uniform circular motion?

- (A) Kinetic energy
- (B) Velocity
- (C) Acceleration
- (D) Displacement
- (E) Linear momentum

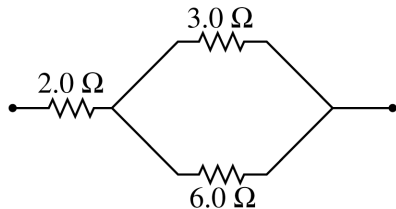

10. What is the equivalent resistance of the combination of resistors shown above?

- (A) $1.0\ \Omega$
- (B) $4.0\ \Omega$
- (C) $5.0\ \Omega$
- (D) $6.5\ \Omega$
- (E) $11.0\ \Omega$

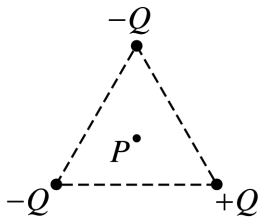

11. Three particles having charges of equal magnitude Q are fixed at the corners of an equilateral triangle as shown above. Two of the charges are negative; the other is positive. Which of the following vectors best represents the direction of the resultant electric field at point P , the center of the triangle?

- (A)
- (B)
- (C)
- (D)
- (E)

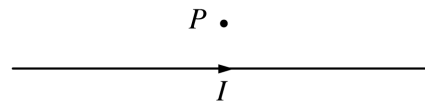

12. A long, straight wire in the plane of the page carries a current I toward the right, as shown above. What is the direction of the magnetic field at point P , which is in the plane of the page and above the wire?

- (A) Out of the page
- (B) Into the page
- (C) Toward the left
- (D) Toward the right
- (E) Toward the wire

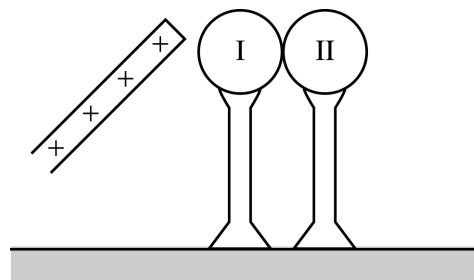

13. Two initially uncharged metal spheres are mounted on insulating stands and placed in contact with each other, as shown above. A student brings a positively charged insulating rod near sphere I. Sphere II is then removed, and finally the rod is moved away. What is the net charge on sphere I?

- (A) No charge
- (B) A positive charge
- (C) A negative charge
- (D) Either a positive or a negative charge, depending on the sizes of the spheres
- (E) Either a positive or a negative charge, depending on the amount of charge on the rod

14. Work is done by a force on a particle in which of the following situations?
- The force is directed parallel to the velocity of the particle.
 - The force results from an electric field that is parallel to the velocity of a charged particle.
 - The force results from a magnetic field that is perpendicular to the velocity of a charged particle.
- (A) II only
 (B) III only
 (C) I and II only
 (D) I and III only
 (E) I, II, and III

15. The magnetic flux for each turn of a 30-turn coil increases from zero to $0.60 \text{ T}\cdot\text{m}^2$ in 3 s. The average emf induced in the coil is
- (A) 6 V
 (B) 18 V
 (C) 54 V
 (D) 90 V
 (E) 150 V

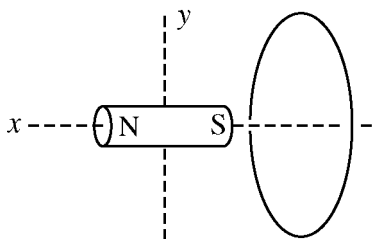

16. The figure above shows a bar magnet and a conducting wire loop that is fixed in place. Which of the following would cause an induced current in the wire?
- Moving the magnet toward the loop at constant speed
 - Rotating the magnet about line x , which lies along the axis of the magnet
 - Rotating the magnet about line y , which is perpendicular to the axis of the magnet
- (A) II only
 (B) III only
 (C) I and II only
 (D) I and III only
 (E) I, II, and III

17. It takes $5.00 \times 10^{-14} \text{ J}$ of work to bring a particle with charge $+Q$ from infinity to a distance of 10.0 cm from positive point charge Y . How much work would be required to bring the particle from infinity to a distance 5.0 cm from Y if the charge on the particle were $+Q/2$ instead?
- (A) $20.0 \times 10^{-14} \text{ J}$
 (B) $10.0 \times 10^{-14} \text{ J}$
 (C) $5.00 \times 10^{-14} \text{ J}$
 (D) $2.50 \times 10^{-14} \text{ J}$
 (E) $1.25 \times 10^{-14} \text{ J}$

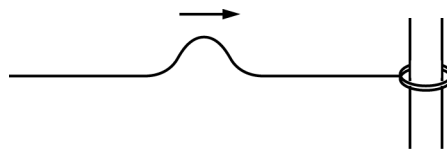

18. One end of a string is attached to a ring of negligible mass that is free to slide along a pole without friction. A transverse wave pulse generated at the other end of the string moves toward the ring as shown above, and is reflected. Properties of the reflected pulse include which of the following?
- It moves faster than the incident pulse.
 - It has greater amplitude than the incident pulse.
 - It is on the same side of the string as the incident pulse.
- (A) I only
 (B) III only
 (C) I and II only
 (D) II and III only
 (E) I, II, and III

Questions 19-20 refer to the following table.

Index of Refraction of Various Substances	
Acetone	1.36
Carbon tetrachloride	1.46
Diamond	2.42
Glass	1.52
Water	1.33

19. Which of the substances in the table would have the smallest critical angle for an interface with air?

- (A) Acetone
- (B) Carbon tetrachloride
- (C) Diamond
- (D) Glass
- (E) Water

20. If light has a speed v in water, what would be its speed in diamond?

- (A) $\frac{v}{2.42}$
- (B) $1.33 v$
- (C) $2.42 v$
- (D) $\frac{1.33}{2.42} v$
- (E) $\frac{2.42}{1.33} v$

21. Which of the following types of electromagnetic radiation have the shortest wavelength?

- (A) Gamma rays
- (B) Microwaves
- (C) Radio waves
- (D) Visible light rays
- (E) X-rays

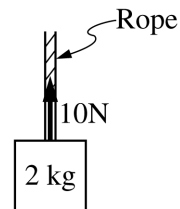

22. A block of mass 2 kg is suspended from a rope, as shown above. If the tension in the rope is 10 N, the acceleration of the block is most nearly

- (A) zero
- (B) 2 m/s^2 up
- (C) 2 m/s^2 down
- (D) 5 m/s^2 up
- (E) 5 m/s^2 down

Questions 23-24

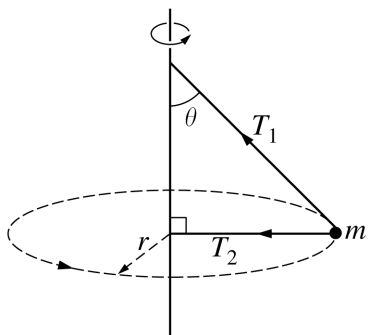

A ball of mass m is attached to a vertical rod by two massless strings. The rod is rotated about its axis so that both strings are taut, with tensions T_1 and T_2 , respectively. The strings and rod form the right triangle shown in the figure above. The ball rotates in a horizontal circle of radius r with speed v .

23. What is the magnitude of the net force on the ball?

- (A) mv^2/r
- (B) mg
- (C) T_2
- (D) $T_2 + mv^2/r$
- (E) $T_1 + mg$

24. What is the tension T_1 in the upper string?

- (A) $mg \cos \theta$
- (B) $mg \sin \theta$
- (C) $mg \tan \theta$
- (D) $mg / \cos \theta$
- (E) $mg / \sin \theta$

25. A toy cannon of mass 1.0 kg is initially at rest on a horizontal surface when it launches a 0.05 kg projectile with a velocity of 10 m/s at an angle of 60° above the horizontal. What is the speed of the 1.0 kg cannon immediately after the projectile is released, assuming that friction is negligible?

- (A) 0.25 m/s
- (B) 0.35 m/s
- (C) 0.43 m/s
- (D) 0.50 m/s
- (E) 0.87 m/s

26. Five spherical planets of uniform density have the relative masses and radii shown below. A satellite of mass m would have the greatest potential energy when orbiting at a radius of $3R$ around which planet?

- (A)
- (B)
- (C)
- (D)
- (E)

Questions 27-28

A ball is dropped and bounces off the floor. Its speed is the same immediately before and immediately after the collision.

27. Which of the following is true about the collision between the ball and the floor?
- (A) The ball's momentum is conserved.
 - (B) The ball's momentum changes direction but not magnitude.
 - (C) The ball's momentum changes magnitude but not direction.
 - (D) The impulse delivered to the ball by the floor is zero.
 - (E) The impulse delivered to the floor by the ball is zero.
28. How does the height to which the ball bounces compare to the height from which it was dropped?
- (A) It is less.
 - (B) It is the same.
 - (C) It is greater.
 - (D) It cannot be determined without knowing the value of the height from which the ball was dropped.
 - (E) It cannot be determined without knowing the value of the ball's speed as it hits the floor.

-
29. Two objects are heated to different temperatures. The objects are then placed in thermal contact with each other and insulated from their surroundings. After equilibrium is reached, which of the following must be true?

- I. The temperatures of the two objects are equal.
- II. The amount of thermal energy lost by one object equals that gained by the other object.
- III. The total energy of the insulated system has not changed.

- (A) I only
- (B) II only
- (C) I and II only
- (D) II and III only
- (E) I, II, and III

30. An air-filled balloon is placed at rest on the bottom of an open vacuum chamber. The chamber is then sealed and most of the air is removed. Which of the following will happen to the balloon?

- I. It will expand.
- II. Its temperature will increase.
- III. It will rise from the bottom.

- (A) I only
- (B) II only
- (C) I and II only
- (D) II and III only
- (E) I, II, and III

31. If energy from the Sun is received at the Earth's surface at the rate of 1200 W/m^2 , the total energy falling on a 100 m^2 area in 1000 s is most nearly

- (A) $1.2 \times 10^{-2} \text{ J}$
- (B) $1.2 \times 10^2 \text{ J}$
- (C) $1.2 \times 10^4 \text{ J}$
- (D) $1.2 \times 10^5 \text{ J}$
- (E) $1.2 \times 10^8 \text{ J}$

32. The equation of continuity for an incompressible fluid, $A_1v_1 = A_2v_2$, is essentially an expression of the conservation of which of the following quantities?

- (A) Energy
- (B) Time
- (C) Linear momentum
- (D) Angular momentum
- (E) Mass

33. A large rock thrown into a pool of water of uniform density becomes completely submerged and then sinks to the bottom. When is the buoyant force on the rock the greatest?

- (A) When it just hits the water
- (B) When it is partially underwater
- (C) When it is completely underwater
- (D) It cannot be determined without knowing the depth of the pool.
- (E) It cannot be determined without knowing the mass of the rock.

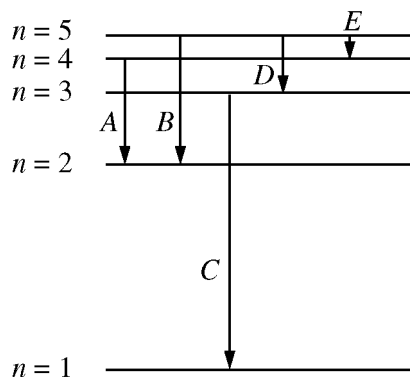

34. The figure above shows part of the energy level diagram for a hypothetical atom. Which of the transitions indicated produces the most energetic photons?

- (A) A
- (B) B
- (C) C
- (D) D
- (E) E

35. Which of the following is true about the momentum of photons?

- (A) Photons have no rest mass, so they have no momentum.
- (B) Photons all travel at the speed of light, so they all have the same momentum.
- (C) The momentum of a photon is directly proportional to its energy.
- (D) The momentum of a photon is directly proportional to its wavelength.
- (E) The momentum of a photon is inversely proportional to the square root of its frequency.

36. When a ${}^9_4\text{Be}$ nucleus absorbs an alpha particle (${}^4_2\alpha$) and emits a ${}^3_2\text{He}$ nucleus, the residual nucleus is

- (A) ${}^8_4\text{Be}$
- (B) ${}^{10}_4\text{Be}$
- (C) ${}^{10}_5\text{B}$
- (D) ${}^{10}_6\text{C}$
- (E) ${}^{10}_3\text{Li}$

37. Which of the following best describes the force that holds a nucleus together?

- (A) A gravitational force
- (B) An electrical force
- (C) A magnetic force
- (D) A short-range, high-magnitude force
- (E) A centrifugal force

38. Light from a very distant source is incident from the left on a barrier containing a single slit. If the width of the slit is much less than the wavelength of the light, which of the following best shows the shape of the wave fronts that are found on the other side of the slit?

- (A)
- (B)
- (C)
- (D)
- (E)

39. A converging lens is used to form a real image of an object placed outside the focal point of the lens. Which of the following would increase the size of the real image?

- (A) Moving the object closer to the lens but keeping it outside the focal point
- (B) Moving the object to a position inside the focal point
- (C) Moving the lens farther from the object
- (D) Replacing the lens with one in the same position with the same focal length but a greater diameter
- (E) Replacing the lens with one in the same position with the same diameter but a smaller focal length

40. A small speaker emits a pulse of sound. The sound has intensity I_1 when it reaches Person 1 at a distance r from the speaker. What is the intensity of the sound when it reaches Person 2 at a distance $2r$ from the speaker?

- (A) $\frac{I_1}{4}$
- (B) $\frac{I_1}{2}$
- (C) I_1
- (D) $2I_1$
- (E) $4I_1$

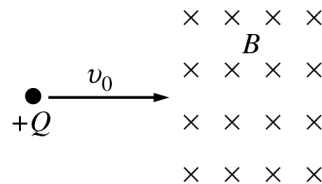

41. A particle of charge $+Q$ moving with speed v_0 enters a region of constant magnetic field B directed into the page, as shown above. The initial direction and magnitude of the acceleration of the particle as it enters the magnetic field is toward the

- (A) bottom of the page and proportional to B
- (B) bottom of the page and proportional to v_0
- (C) top of the page and inversely proportional to v_0
- (D) top of the page and inversely proportional to B
- (E) top of the page and proportional to both B and v_0

42. The capacitance of a parallel-plate capacitor depends on which of the following?

- I. The plate area
- II. The plate separation
- III. The charge stored on the capacitor

- (A) I only
- (B) III only
- (C) I and II only
- (D) II and III only
- (E) I, II, and III

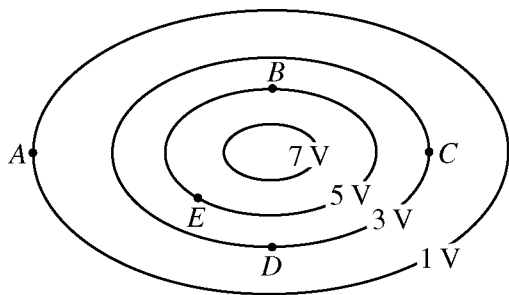

43. The elliptical equipotential lines resulting from a particular charge distribution are shown in the figure above. At which of the labeled points will a proton experience an electric force directed toward the top of the page?

- (A) A
- (B) B
- (C) C
- (D) D
- (E) E

44. When charges Q of equal magnitude and opposite sign are placed on the plates of a parallel-plate capacitor of capacitance C , the voltage between the plates is V and the energy stored in the capacitor is U . If C is doubled and Q is not changed, how are V and U affected?

- | V | U |
|-----------------|-------------|
| (A) Halved | Halved |
| (B) Halved | Quartered |
| (C) Not changed | Not changed |
| (D) Doubled | Doubled |
| (E) Doubled | Quadrupled |

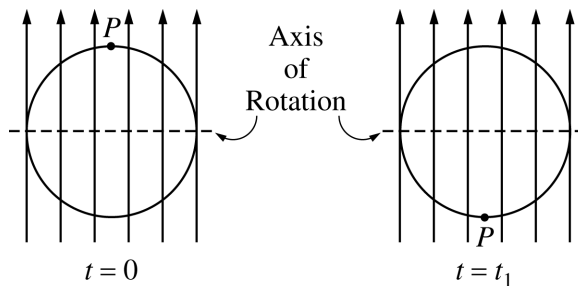

45. A circular loop of wire in a uniform magnetic field rotates at a constant rotational speed about the axis shown. At time $t = 0$ the plane of the loop is parallel to the field with point P at the top as shown above left. At time $t = t_1$ the loop has rotated 180° so that point P is at the bottom as shown above right. Which of the following graphs best represents the magnetic flux through the loop as a function of time t from 0 to t_1 ?

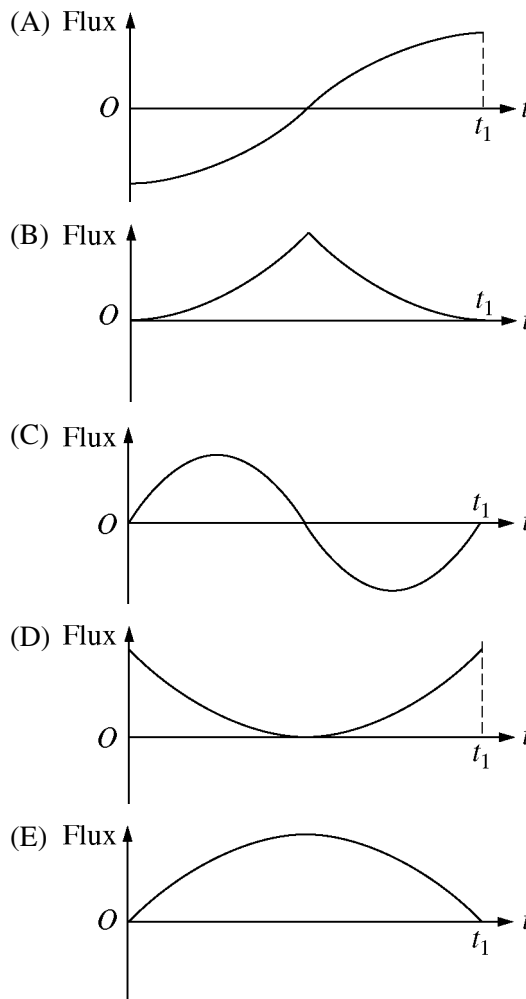

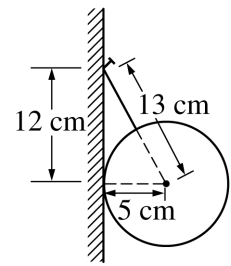
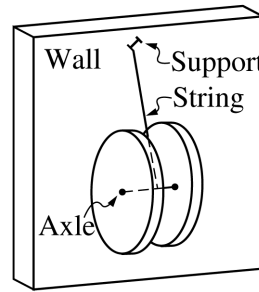
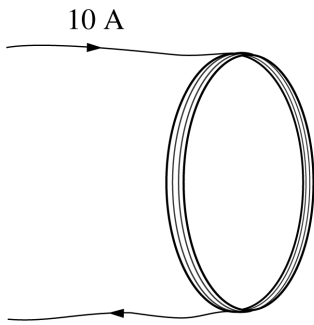

(Side View)

46. A flat coil of wire carrying a current of 10 A, as shown above, produces a magnetic field of 5.0×10^{-3} T near its center. Additional loops of the same diameter are added to increase the number of loops in the coil from 4 to 16, and the current is kept the same. The magnetic field at the same point due to the new coil is most nearly
- (A) 8.0×10^{-2} T
 (B) 2.0×10^{-2} T
 (C) 5.0×10^{-3} T
 (D) 2.5×10^{-3} T
 (E) 1.3×10^{-3} T

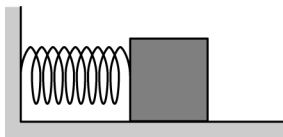

47. A block on a horizontal surface of negligible friction is placed in contact with an ideal spring, as shown above. The block is moved to the left so that the spring is compressed a distance x from equilibrium and then released from rest. The block has kinetic energy K_1 when it separates from the spring. When the spring is compressed a distance $2x$ and the block is released from rest, the kinetic energy of the block when it separates from the spring is
- (A) $K_1/2$
 (B) K_1
 (C) $\sqrt{2}K_1$
 (D) $2K_1$
 (E) $4K_1$

48. A uniform spool is suspended from a vertical wall by a string attached to the spool's thin axle. The axle is horizontal, as shown above. The wall is smooth, so it exerts no frictional force on the spool. The tension in the string is 2.6 N. What is the weight of the spool?
- (A) 0.5 N
 (B) 1.0 N
 (C) 1.2 N
 (D) 2.4 N
 (E) 2.6 N
49. A spaceship is traveling from Earth to the Moon. Which of the following is true of the gravitational force on the ship due to the two objects when the ship is equidistant from Earth and the Moon?
- (A) There is no net force because the ship is beyond the influence of Earth and the Moon.
 (B) There is no net force because the forces exerted by Earth and the Moon balance.
 (C) There is a net force because the force exerted by Earth is smaller than that exerted by the Moon.
 (D) There is a net force because the force exerted by Earth is greater than that exerted by the Moon.
 (E) There is a net force because the ship must be accelerating toward the Moon.

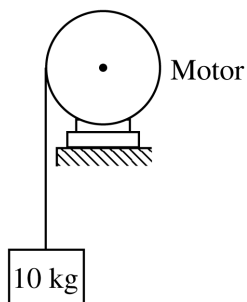

50. A 10 kg block is attached to a light cord that is wrapped around the pulley of an electric motor, as shown above. At what rate is the motor doing work when it is pulling the block upward with an instantaneous speed of 3 m/s and an upward acceleration of 2 m/s^2 ?

- (A) 120 W
- (B) 240 W
- (C) 300 W
- (D) 360 W
- (E) 600 W

51. A ball is tossed straight up and later returns to the point from which it was launched. If the ball is subject to air resistance as well as gravity, which of the following statements is correct?

- (A) The speed at which the ball returns to the point of launch is less than its speed when it was initially launched.
- (B) The time for the ball to fall is the same as the time for the ball to rise.
- (C) The force of air resistance is directed downward both when the ball is rising and when it is falling.
- (D) The net work done by air resistance on the ball during its flight is zero.
- (E) The net work done by gravity on the ball during its flight is greater than zero.

52. Each of the following atoms is stripped of all orbital electrons and they are all placed in the same electric field. Which ionized atom in the field is acted on by the strongest electrostatic force?

- (A) $^{12}_6\text{C}$
- (B) $^{12}_7\text{N}$
- (C) $^{16}_8\text{O}$
- (D) $^{19}_8\text{O}$
- (E) $^{17}_9\text{F}$

53. An atomic particle of mass m moving with a speed v has a wavelength λ_1 . A second particle with the same mass m moves with speed $3v$ and has a wavelength λ_2 . What is the relationship between λ_1 and λ_2 ?

- (A) $\lambda_2 = \frac{1}{9}\lambda_1$
- (B) $\lambda_2 = \frac{1}{3}\lambda_1$
- (C) $\lambda_2 = \lambda_1$
- (D) $\lambda_2 = 3\lambda_1$
- (E) $\lambda_2 = 9\lambda_1$

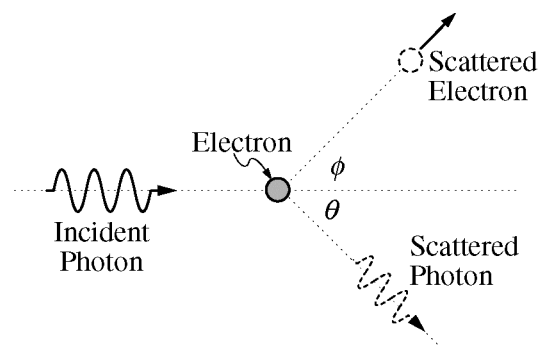

54. A photon scatters from an electron that is initially at rest, as shown above. Which of the following is true of the wavelength and frequency of the scattered photon compared to those of the incident photon?

- | <u>Wavelength</u> | <u>Frequency</u> |
|-------------------|------------------|
| (A) Greater | Less |
| (B) Greater | The same |
| (C) The same | Less |
| (D) Less | Greater |
| (E) Less | The same |

Questions 55-56

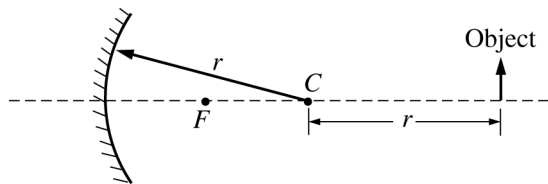

The concave spherical mirror of radius r shown above has focal point F and center of curvature C . An object is placed at a distance $2r$ from the mirror.

55. Where will the image be formed?
- (A) To the left of the mirror
 (B) Between F and the mirror
 (C) Between F and C
 (D) Between C and the object
 (E) To the right of the object
56. Which of the following correctly describes the image?
- (A) Real, inverted, smaller than the object
 (B) Real, inverted, larger than the object
 (C) Real, upright, smaller than the object
 (D) Virtual, upright, smaller than the object
 (E) Virtual, inverted, larger than the object

-
57. Two waves from the same source travel different distances to point P . One wave has amplitude A and the other has amplitude $0.50A$. The resultant amplitude from the superposition of the two waves at point P CANNOT be
- (A) $0.25A$
 (B) $0.5A$
 (C) $0.75A$
 (D) A
 (E) $1.25A$

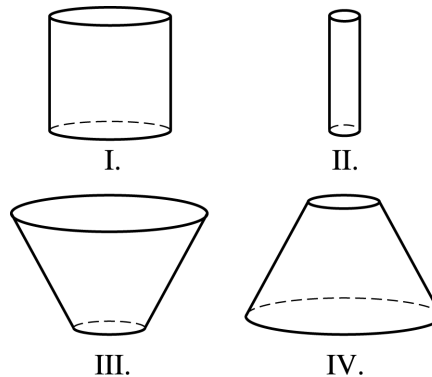

58. The containers pictured above are each filled to a height h with the same fluid of uniform density. Which of the following is true of the pressures, p_I , p_{II} , p_{III} , and p_{IV} , at the bottom of each respective container?
- (A) $p_{III} > p_I > p_{II} > p_{IV}$
 (B) $p_I > p_{II} > p_{III} > p_{IV}$
 (C) $p_I = p_{II}$; $p_{III} > p_{IV}$
 (D) $p_I > p_{II}$; $p_{III} = p_{IV}$
 (E) They are all the same.

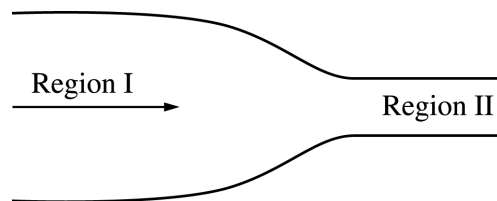

59. The diagram above shows a pipe with an ideal fluid in motion to the right. As the fluid enters region II, which of the following quantities related to the fluid will increase?
- I. Pressure
 II. Linear speed
 III. Volume rate of flow
- (A) I only
 (B) II only
 (C) III only
 (D) I and II
 (E) II and III

Questions 60-61

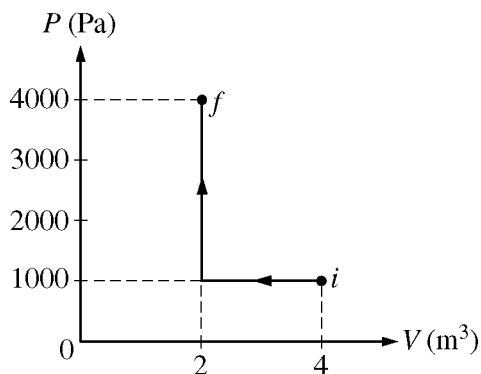

A gas is taken from state *i* to state *f* along the two-step process shown in the *PV* diagram above.

60. How much work is done on the gas during the process described?

- (A) 0 J
- (B) 2000 J
- (C) 4000 J
- (D) 8000 J
- (E) 16,000 J

61. What is the ratio T_f/T_i of the temperature of state *f* to the temperature of state *i*?

- (A) 1
- (B) 4/3
- (C) 3/2
- (D) 2
- (E) 4

62. Energy levels of atoms in a gas are experimentally determined from the

- (A) line spectrum produced by the gas
- (B) bulk density of the gas
- (C) electrical conductivity of the gas
- (D) chemical properties of the gas
- (E) isotopic composition of the gas

63. The work function for tungsten is 4.58 eV. Of the following, which is the best estimate of the threshold frequency required for the emission of photoelectrons from a tungsten cathode?

- (A) 0.1×10^{15} Hz
- (B) 0.5×10^{15} Hz
- (C) 1×10^{15} Hz
- (D) 2×10^{15} Hz
- (E) 3×10^{15} Hz

64. A circular wire loop is placed near a long, straight, current-carrying wire in which the current is either increasing or decreasing. In which of the following situations is the induced current in the loop counterclockwise?

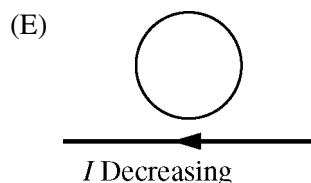
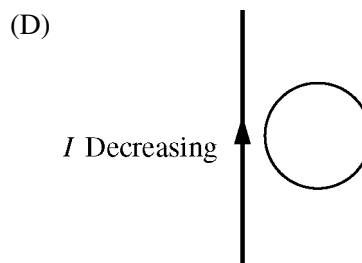
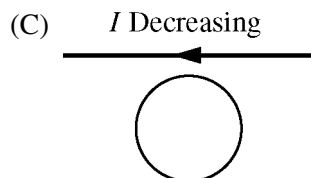
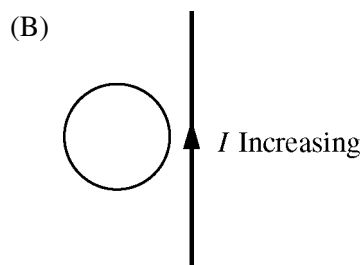
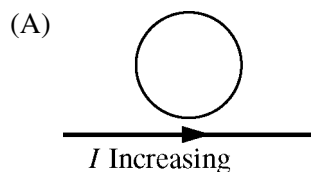

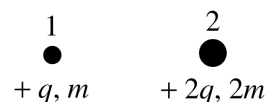
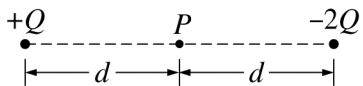

65. Two point charges, $+Q$ and $-2Q$, are fixed in place at a distance $2d$ from each other, as shown above. What is the magnitude of the net electric field at a point P , which is midway between the two charges?

- (A) $\frac{kQ}{d}$
 (B) $\frac{3kQ}{d}$
 (C) $\frac{kQ}{d^2}$
 (D) $\frac{2kQ}{d^2}$
 (E) $\frac{3kQ}{d^2}$

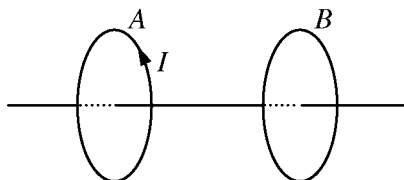

66. The two circular wire loops represented above are coaxial. If the current I in loop A is increasing linearly with respect to time, which of the following is true of the induced current in loop B ?

- (A) It is in the same direction as that in loop A and also increasing with respect to time.
 (B) It is in the opposite direction of that in loop A and also increasing with respect to time.
 (C) It is in the same direction as that in loop A and constant with respect to time.
 (D) It is in the opposite direction of that in loop A and constant with respect to time.
 (E) None of the above

67. An isolated system consists of the two particles shown above. Particle 1 has charge $+q$ and mass m . Particle 2 has charge $+2q$ and mass $2m$. The ratio of the magnitude of the electrical force on particle 1 to the magnitude of the electrical force on particle 2 is

- (A) $\frac{1}{4}$
 (B) $\frac{1}{2}$
 (C) 1
 (D) 2
 (E) 4

68. Two charged metal spheres are connected by a conducting wire. Sphere A is larger than sphere B . Which of the following is true of the magnitude of the electric potential at the surface of sphere A compared to that at the surface of sphere B ?

- (A) It is greater.
 (B) It is less.
 (C) It is the same.
 (D) It could be greater or less, depending on the ratio of the radii of the spheres.
 (E) It could be greater or less, depending on the charges of the spheres.

69. The displacement x with respect to time t of a particle moving in simple harmonic motion is given by $x = 5 \cos(16\pi t)$, where x is in millimeters and t is in seconds. If the particle starts at $x = 5$ mm and $t = 0$ s, at what time t does it first pass through its equilibrium position?
- (A) $\frac{1}{32}$ s
(B) $\frac{1}{16}$ s
(C) $\frac{1}{5}$ s
(D) 4 s
(E) 8 s
70. A 100 kg cart goes around the inside of a vertical loop of a roller coaster. The radius of the loop is 3 m and the cart moves at a speed of 6 m/s at the top. The force exerted by the track on the cart at the top of the loop is
- (A) 200 N
(B) 800 N
(C) 1000 N
(D) 1200 N
(E) 2200 N

S T O P

END OF SECTION I

**IF YOU FINISH BEFORE TIME IS CALLED
YOU MAY CHECK YOUR WORK ON THIS SECTION.**

DO NOT GO ON TO SECTION II UNTIL YOU ARE TOLD TO DO SO.

MAKE SURE YOU HAVE DONE THE FOLLOWING.

- **PLACED YOUR AP NUMBER LABEL ON YOUR ANSWER SHEET**
- **WRITTEN AND GRIDDED YOUR AP NUMBER CORRECTLY ON YOUR ANSWER SHEET**
- **TAKEN THE AP EXAM LABEL FROM THE FRONT OF THIS BOOKLET AND PLACED IT ON YOUR ANSWER SHEET**

GO ON TO THE NEXT PAGE.

Section II: Free-Response Questions

This is the free-response section of the 2012 AP exam. It includes cover material and other administrative instructions to help familiarize students with the mechanics of the exam. (Note that future exams may differ in look from the following content.)

AP[®] Physics B Exam

SECTION II: Free Response

2012

DO NOT OPEN THIS BOOKLET UNTIL YOU ARE TOLD TO DO SO.

At a Glance

Total Time

1 hour, 30 minutes

Number of Questions

6

Percent of Total Score

50%

Writing Instrument

Either pencil or pen with black or dark blue ink

Electronic Device

Calculator allowed

Percent of Section II Score

Questions 5 and 6:
25%

Questions 1, 2, 3, and 4:
75%

IMPORTANT Identification Information

PLEASE PRINT WITH PEN:

1. First two letters of your last name
First letter of your first name
2. Date of birth

Month Day Year
3. Six-digit school code
4. Unless I check the box below, I grant the College Board the unlimited right to use, reproduce, and publish my free-response materials, both written and oral, for educational research and instructional purposes. My name and the name of my school will not be used in any way in connection with my free-response materials. I understand that I am free to mark "No" with no effect on my score or its reporting.
No, I do not grant the College Board these rights.

Instructions

The questions for Section II are printed in this booklet. You may use any blank space in the booklet for scratch work, but you must write your answers in the spaces provided for each answer. A table of information and lists of equations that may be helpful are in the booklet. Calculators, rulers, and straightedges may be used in this section.

All final numerical answers should include appropriate units. Credit for your work depends on demonstrating that you know which physical principles would be appropriate to apply in a particular situation. Therefore, you should show your work for each part in the space provided after that part. If you need more space, be sure to clearly indicate where you continue your work. Credit will be awarded only for work that is clearly designated as the solution to a specific part of a question. Credit also depends on the quality of your solutions and explanations, so you should show your work.

Write clearly and legibly. Cross out any errors you make; erased or crossed-out work will not be scored. You may lose credit for incorrect work that is not crossed out.

Manage your time carefully. You may proceed freely from one question to the next. You may review your responses if you finish before the end of the exam is announced.



Minimum 20% post-consumer waste

Form I
Form Code Z2-4ABP2-S

78

TABLE OF INFORMATION DEVELOPED FOR 2012

CONSTANTS AND CONVERSION FACTORS	
Proton mass, $m_p = 1.67 \times 10^{-27}$ kg	Electron charge magnitude, $e = 1.60 \times 10^{-19}$ C
Neutron mass, $m_n = 1.67 \times 10^{-27}$ kg	1 electron volt, $1 \text{ eV} = 1.60 \times 10^{-19}$ J
Electron mass, $m_e = 9.11 \times 10^{-31}$ kg	Speed of light, $c = 3.00 \times 10^8$ m/s
Avogadro's number, $N_0 = 6.02 \times 10^{23}$ mol ⁻¹	Universal gravitational constant, $G = 6.67 \times 10^{-11}$ m ³ /kg·s ²
Universal gas constant, $R = 8.31$ J/(mol·K)	Acceleration due to gravity at Earth's surface, $g = 9.8$ m/s ²
Boltzmann's constant, $k_B = 1.38 \times 10^{-23}$ J/K	
1 unified atomic mass unit,	$1 \text{ u} = 1.66 \times 10^{-27}$ kg = $931 \text{ MeV}/c^2$
Planck's constant,	$h = 6.63 \times 10^{-34}$ J·s = 4.14×10^{-15} eV·s
	$hc = 1.99 \times 10^{-25}$ J·m = 1.24×10^3 eV·nm
Vacuum permittivity,	$\epsilon_0 = 8.85 \times 10^{-12}$ C ² /N·m ²
Coulomb's law constant, $k = 1/4\pi\epsilon_0 = 9.0 \times 10^9$ N·m ² /C ²	
Vacuum permeability,	$\mu_0 = 4\pi \times 10^{-7}$ (T·m)/A
Magnetic constant, $k' = \mu_0/4\pi = 1 \times 10^{-7}$ (T·m)/A	
1 atmosphere pressure,	$1 \text{ atm} = 1.0 \times 10^5$ N/m ² = 1.0×10^5 Pa

UNIT SYMBOLS	meter, m	mole, mol	watt, W	farad, F
	kilogram, kg	hertz, Hz	coulomb, C	tesla, T
	second, s	newton, N	volt, V	degree Celsius, °C
	ampere, A	pascal, Pa	ohm, Ω	electron-volt, eV
	kelvin, K	joule, J	henry, H	

PREFIXES		
Factor	Prefix	Symbol
10 ⁹	giga	G
10 ⁶	mega	M
10 ³	kilo	k
10 ⁻²	centi	c
10 ⁻³	milli	m
10 ⁻⁶	micro	μ
10 ⁻⁹	nano	n
10 ⁻¹²	pico	p

VALUES OF TRIGONOMETRIC FUNCTIONS FOR COMMON ANGLES							
θ	0°	30°	37°	45°	53°	60°	90°
$\sin \theta$	0	1/2	3/5	$\sqrt{2}/2$	4/5	$\sqrt{3}/2$	1
$\cos \theta$	1	$\sqrt{3}/2$	4/5	$\sqrt{2}/2$	3/5	1/2	0
$\tan \theta$	0	$\sqrt{3}/3$	3/4	1	4/3	$\sqrt{3}$	∞

The following conventions are used in this exam.

- I. Unless otherwise stated, the frame of reference of any problem is assumed to be inertial.
- II. The direction of any electric current is the direction of flow of positive charge (conventional current).
- III. For any isolated electric charge, the electric potential is defined as zero at an infinite distance from the charge.
- IV. For mechanics and thermodynamics equations, W represents the work done on a system.

ADVANCED PLACEMENT PHYSICS B EQUATIONS DEVELOPED FOR 2012

NEWTONIAN MECHANICS		ELECTRICITY AND MAGNETISM	
$v = v_0 + at$	$a =$ acceleration	$F = \frac{kq_1q_2}{r^2}$	$A =$ area
$x = x_0 + v_0t + \frac{1}{2}at^2$	$F =$ force	$\mathbf{E} = \frac{\mathbf{F}}{q}$	$B =$ magnetic field
$v^2 = v_0^2 + 2a(x - x_0)$	$f =$ frequency	$U_E = qV = \frac{kq_1q_2}{r}$	$C =$ capacitance
$\Sigma \mathbf{F} = \mathbf{F}_{net} = m\mathbf{a}$	$h =$ height	$E_{avg} = -\frac{V}{d}$	$d =$ distance
$F_{fric} \leq \mu N$	$J =$ impulse	$V = k\left(\frac{q_1}{r_1} + \frac{q_2}{r_2} + \frac{q_3}{r_3} + \dots\right)$	$E =$ electric field
$a_c = \frac{v^2}{r}$	$K =$ kinetic energy	$C = \frac{Q}{V}$	$\mathcal{E} =$ emf
$\tau = rF \sin \theta$	$k =$ spring constant	$C = \frac{\epsilon_0 A}{d}$	$F =$ force
$\mathbf{p} = m\mathbf{v}$	$\ell =$ length	$U_c = \frac{1}{2}QV = \frac{1}{2}CV^2$	$I =$ current
$\mathbf{J} = \mathbf{F}\Delta t = \Delta \mathbf{p}$	$m =$ mass	$I_{avg} = \frac{\Delta Q}{\Delta t}$	$\ell =$ length
$K = \frac{1}{2}mv^2$	$N =$ normal force	$R = \frac{\rho \ell}{A}$	$P =$ power
$\Delta U_g = mgh$	$P =$ power	$V = IR$	$Q =$ charge
$W = F\Delta r \cos \theta$	$p =$ momentum	$P = IV$	$q =$ point charge
$P_{avg} = \frac{W}{\Delta t}$	$r =$ radius or distance	$C_p = C_1 + C_2 + C_3 + \dots$	$R =$ resistance
$P = Fv \cos \theta$	$T =$ period	$\frac{1}{C_s} = \frac{1}{C_1} + \frac{1}{C_2} + \frac{1}{C_3} + \dots$	$r =$ distance
$\mathbf{F}_s = -k\mathbf{x}$	$t =$ time	$R_s = R_1 + R_2 + R_3 + \dots$	$t =$ time
$U_s = \frac{1}{2}kx^2$	$U =$ potential energy	$\frac{1}{R_p} = \frac{1}{R_1} + \frac{1}{R_2} + \frac{1}{R_3} + \dots$	$U =$ potential (stored) energy
$T_s = 2\pi\sqrt{\frac{m}{k}}$	$v =$ velocity or speed	$F_B = qvB \sin \theta$	$V =$ electric potential or potential difference
$T_p = 2\pi\sqrt{\frac{\ell}{g}}$	$W =$ work done on a system	$F_B = BI\ell \sin \theta$	$v =$ velocity or speed
$T = \frac{1}{f}$	$x =$ position	$B = \frac{\mu_0 I}{2\pi r}$	$\rho =$ resistivity
$F_G = -\frac{Gm_1m_2}{r^2}$	$\mu =$ coefficient of friction	$\phi_m = BA \cos \theta$	$\theta =$ angle
$U_G = -\frac{Gm_1m_2}{r}$	$\theta =$ angle	$\mathcal{E}_{avg} = -\frac{\Delta \phi_m}{\Delta t}$	$\phi_m =$ magnetic flux
	$\tau =$ torque	$\mathcal{E} = B\ell v$	

ADVANCED PLACEMENT PHYSICS B EQUATIONS DEVELOPED FOR 2012

FLUID MECHANICS AND THERMAL PHYSICS

$\rho = m/V$	$A = \text{area}$
$P = P_0 + \rho gh$	$e = \text{efficiency}$
$F_{buoy} = \rho Vg$	$F = \text{force}$
$A_1v_1 = A_2v_2$	$h = \text{depth}$
$P + \rho gy + \frac{1}{2}\rho v^2 = \text{const.}$	$H = \text{rate of heat transfer}$
$\Delta\ell = \alpha\ell_0\Delta T$	$k = \text{thermal conductivity}$
$H = \frac{kA\Delta T}{L}$	$K_{avg} = \text{average molecular kinetic energy}$
$P = \frac{F}{A}$	$\ell = \text{length}$
$PV = nRT = Nk_B T$	$L = \text{thickness}$
$K_{avg} = \frac{3}{2}k_B T$	$m = \text{mass}$
$v_{rms} = \sqrt{\frac{3RT}{M}} = \sqrt{\frac{3k_B T}{\mu}}$	$M = \text{molar mass}$
$W = -P\Delta V$	$n = \text{number of moles}$
$\Delta U = Q + W$	$N = \text{number of molecules}$
$e = \left \frac{W}{Q_H} \right $	$P = \text{pressure}$
$e_c = \frac{T_H - T_C}{T_H}$	$Q = \text{heat transferred to a system}$
	$T = \text{temperature}$
	$U = \text{internal energy}$
	$V = \text{volume}$
	$v = \text{velocity or speed}$
	$v_{rms} = \text{root-mean-square velocity}$
	$W = \text{work done on a system}$
	$y = \text{height}$
	$\alpha = \text{coefficient of linear expansion}$
	$\mu = \text{mass of molecule}$
	$\rho = \text{density}$

ATOMIC AND NUCLEAR PHYSICS

$E = hf = pc$	$E = \text{energy}$
$K_{max} = hf - \phi$	$f = \text{frequency}$
$\lambda = \frac{h}{p}$	$K = \text{kinetic energy}$
$\Delta E = (\Delta m)c^2$	$m = \text{mass}$
	$p = \text{momentum}$
	$\lambda = \text{wavelength}$
	$\phi = \text{work function}$

WAVES AND OPTICS

$v = f\lambda$	$d = \text{separation}$
$n = \frac{c}{v}$	$f = \text{frequency or focal length}$
$n_1 \sin \theta_1 = n_2 \sin \theta_2$	$h = \text{height}$
$\sin \theta_c = \frac{n_2}{n_1}$	$L = \text{distance}$
$\frac{1}{s_i} + \frac{1}{s_o} = \frac{1}{f}$	$M = \text{magnification}$
$M = \frac{h_i}{h_o} = -\frac{s_i}{s_o}$	$m = \text{an integer}$
$f = \frac{R}{2}$	$n = \text{index of refraction}$
$d \sin \theta = m\lambda$	$R = \text{radius of curvature}$
$x_m \approx \frac{m\lambda L}{d}$	$s = \text{distance}$
	$v = \text{speed}$
	$x = \text{position}$
	$\lambda = \text{wavelength}$
	$\theta = \text{angle}$

GEOMETRY AND TRIGONOMETRY

Rectangle	$A = \text{area}$
$A = bh$	$C = \text{circumference}$
Triangle	$V = \text{volume}$
$A = \frac{1}{2}bh$	$S = \text{surface area}$
Circle	$b = \text{base}$
$A = \pi r^2$	$h = \text{height}$
$C = 2\pi r$	$\ell = \text{length}$
Rectangular Solid	$w = \text{width}$
$V = \ell wh$	$r = \text{radius}$
Cylinder	
$V = \pi r^2 \ell$	
$S = 2\pi r \ell + 2\pi r^2$	
Sphere	

$$V = \frac{4}{3}\pi r^3$$

$$S = 4\pi r^2$$

Right Triangle

$$a^2 + b^2 = c^2$$

$$\sin \theta = \frac{a}{c}$$

$$\cos \theta = \frac{b}{c}$$

$$\tan \theta = \frac{a}{b}$$

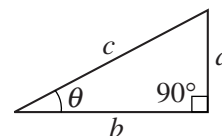

PHYSICS B
SECTION II
Time—90 minutes
6 Questions

Directions: Answer all six questions, which are weighted according to the points indicated. The suggested times are about 17 minutes for answering each of Questions 1-4 and about 11 minutes for answering each of Questions 5-6. The parts within a question may not have equal weight. Show all your work in this booklet in the spaces provided after each part.

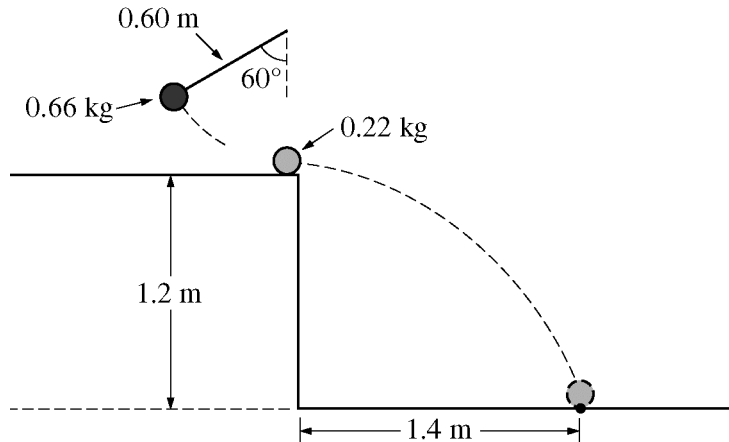

1. (15 points)

The experimental apparatus shown in the figure above contains a pendulum consisting of a 0.66 kg ball attached to a string of length 0.60 m. The pendulum is released from rest at an angle of 60° and collides with a ball of mass 0.22 kg initially at rest at the edge of a table. The 0.22 kg ball hits the floor a distance of 1.4 m from the edge of the table.

(a) Calculate the speed of the 0.66 kg ball just before the collision.

(b) Calculate the speed of the 0.22 kg ball immediately after the collision.

(c) Calculate the speed of the 0.66 kg ball immediately after the collision.

(d) Indicate the direction of motion of the 0.66 kg ball immediately after the collision.

To the left To the right

(e) Calculate the height to which the 0.66 kg ball rises after the collision.

(f) Based on your data, is the collision elastic?

Yes No

Justify your answer.

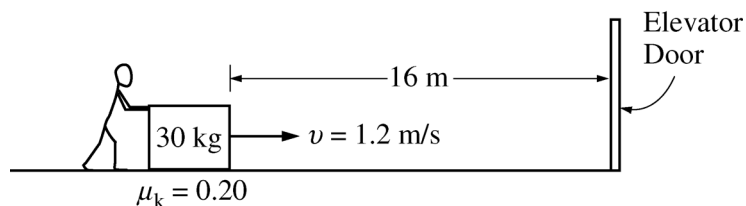

2. (15 points)

Beginning at time $t = 0$, a student exerts a horizontal force on a box of mass 30 kg, causing it to move at 1.2 m/s toward an elevator door located 16 m away, as shown above. The coefficient of kinetic friction μ_k between the box and the floor is 0.20.

(a) On the dot below that represents the box, draw and label the forces (not components) that act on the box as it moves at constant speed.



(b) Calculate the magnitude of the horizontal force the student must exert on the box in order to keep it moving at 1.2 m/s. If you need to draw anything other than what you have shown in part (a) to assist in your solution, use the space below. Do NOT add anything to the figure in part (a).

At $t = 4.0$ s, the elevator door opens and remains open for 5.0 s. The student immediately exerts a larger constant force on the box and the front of the box reaches the elevator door just as it starts to close.

(c) Calculate the magnitude of the new force that the student exerts.

(d) On the axes below, sketch graphs of the acceleration a , velocity v , and position x of the box versus time t between $t = 0$ and the time the front of the box reaches the elevator.

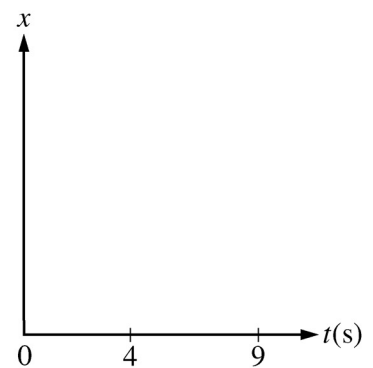
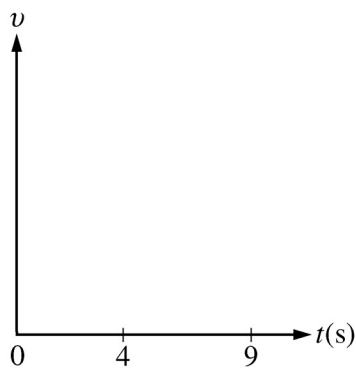
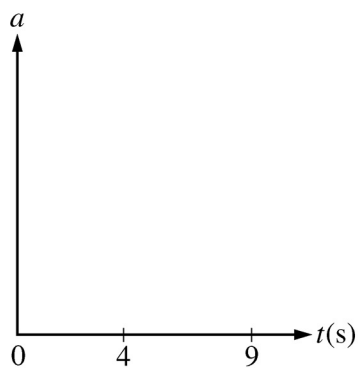

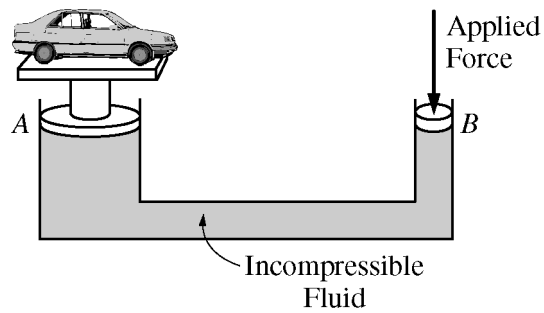

Note: Figure not drawn to scale.

3. (15 points)

A car of mass 1200 kg sits on a hydraulic lift as shown above. The radius of piston A is 0.30 m, and the radius of piston B is 0.10 m. Ignore any pressure effects caused by differences in heights of the fluids.

(a) Piston B is pushed a distance of 2.5 m, raising the car slowly at constant speed. Calculate each of the following.

i. The magnitude of the applied force on piston B

ii. The vertical distance moved by the car

(b) Calculate the work done by the applied force in lifting the car.

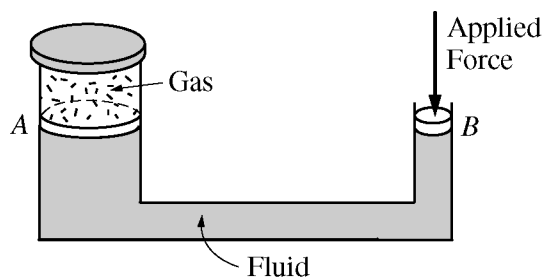

Note: Figure not drawn to scale.

Instead of the lift, a cap is fixed to the top of the pipe above piston *A*, and the space between *A* and the cap is filled with an ideal gas, as shown above. A force is applied to piston *B*, compressing the gas above piston *A*.

- (c) Assume the compression occurs at constant temperature. Sketch the process on the axes below, and indicate its direction.

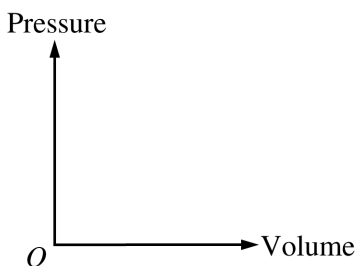

- (d) Suppose instead that the compression occurs at constant pressure.

- i. Sketch the process on the axes below, and indicate its direction.

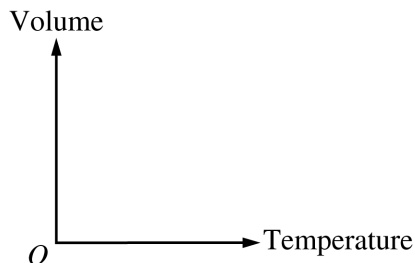

- ii. Is heat added to or removed from the gas?

Heat is added. Heat is removed. There is no net heat exchange.

Justify your answer.

4. (15 points)

A 120 V power supply is connected through a 20 A fuse to a circuit in which a coffeemaker is connected in parallel with a toaster. When each device is individually connected to the 120 V power supply, the coffeemaker dissipates energy at the rate of 300 W, and the toaster dissipates energy at a rate of 1000 W. The fuse is a safety device in which a wire of negligible resistance will melt and break the circuit when the current through it exceeds 20 A (called “blowing the fuse”).

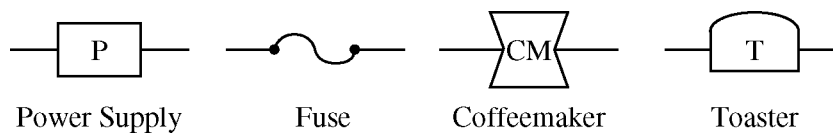

(a) Using the symbols above, draw a circuit diagram below showing the power supply, the fuse, and the two appliances.

(b) Calculate the current through the fuse when both appliances are operating at the given energy rates.

(c) Calculate the resistance of each appliance when operating at the given energy rates.

(d) Calculate the maximum power rating of a hair dryer that could be operated in parallel with the other two appliances without blowing the fuse.

(e) Can the coffeemaker and toaster be connected in series with the power supply without blowing the fuse when they are turned on?

Yes No

Justify your answer.

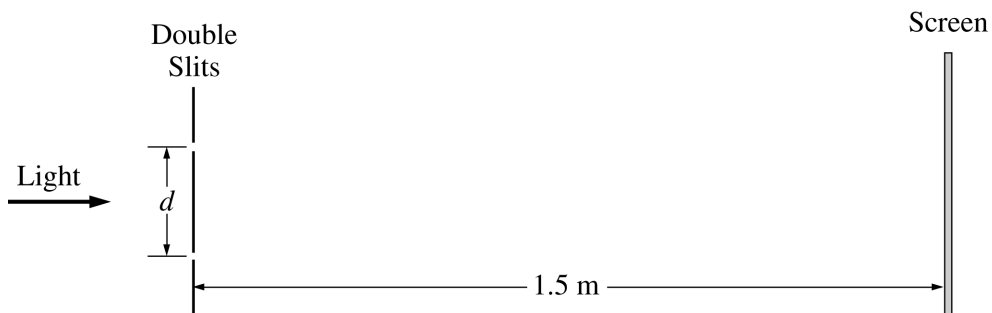

Note: Figure not drawn to scale.

5. (10 points)

In a Young's double-slit experiment, a laser beam of wavelength 670 nm is passed through two slits and an interference pattern is formed on a screen placed 1.5 m from the slits, as shown above. A ruler with millimeter markings is placed alongside the interference pattern to measure the fringe spacing z . The figure below is a scale drawing of the pattern and ruler.

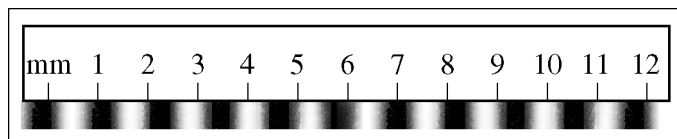

Fringes on the screen for the 670 nm laser

(a) From the figure above, calculate the best value of the fringe spacing z .

(b) Calculate the spacing d between the slits.

The original laser beam is now replaced by a new laser beam of an unknown wavelength λ_u . A scale drawing of the new interference pattern formed is given below.

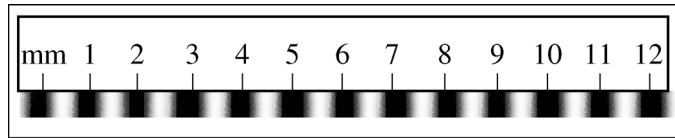

Fringes on the screen for the unknown light

- (c) From the figure above, calculate the unknown wavelength λ_u for this light.
- (d) If the accepted wavelength of the second beam is 530 nm, calculate the percentage error in your answer to part (c).

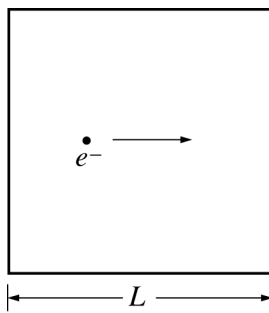

6. (10 points)

A moving electron of mass m_e is confined between two rigid walls of a box of length $L = 1.7 \times 10^{-10}$ m, as represented above. The electron can be associated with a standing wave. The possible standing waves are similar to standing waves on a string whose ends are fixed on opposite walls of the box, with wavelengths given by $\lambda = 2L/n$, where n is an integer ≥ 1 .

(a)

i. Determine the wavelength λ_1 of the fundamental (first harmonic) of standing waves associated with the electron.

ii. Determine the wavelength λ_2 of the first overtone (second harmonic) of standing waves associated with the electron.

iii. On the dashed lines below, each of length L , sketch the shape of the first two standing wave patterns associated with the electron.

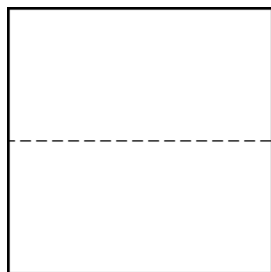

Fundamental

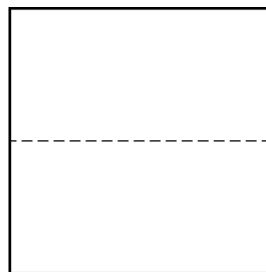

First Overtone

(b) Starting with an equation for the de Broglie wavelength, derive an expression for the speed of the electron in terms of n , h , m_e , and L .

(c) Calculate the numerical value of the kinetic energy of the electron associated with the fundamental standing wave.

STOP

END OF EXAM

THE FOLLOWING INSTRUCTIONS APPLY TO THE COVERS OF THE SECTION II BOOKLET.

- **MAKE SURE YOU HAVE COMPLETED THE IDENTIFICATION INFORMATION AS REQUESTED ON THE FRONT AND BACK COVERS OF THE SECTION II BOOKLET.**
- **CHECK TO SEE THAT YOUR AP NUMBER LABEL APPEARS IN THE BOX(ES) ON THE COVER(S).**
- **MAKE SURE YOU HAVE USED THE SAME SET OF AP NUMBER LABELS ON ALL AP EXAMS YOU HAVE TAKEN THIS YEAR.**

Multiple-Choice Answer Key

The following contains the answers to the multiple-choice questions in this exam.

**Answer Key for AP Physics B
Practice Exam, Section I**

Multiple-Choice Questions	
Question #	Key
1	E
2	E
3	B
4	D
5	C
6	E
7	B
8	C
9	A
10	B
11	A
12	A
13	C
14	C
15	A
16	D
17	C
18	B
19	C
20	D
21	A
22	E
23	A
24	D
25	A
26*	—
27	B
28	B
29	E
30	A
31	E
32	E
33	C
34	C

35	C
36	B
37	D
38	B
39	A
40	A
41	E
42	C
43	B
44	A
45	E
46	B
47	E
48	D
49	D
50	D
51	A
52	E
53	B
54	A
55	C
56	A
57	A
58	E
59	B
60	B
61	D
62	A
63	C
64	C
65	E
66	D
67	C
68	C
69	A
70	A

*Item 26 was not used in scoring.

Free-Response Scoring Guidelines

The following contains the scoring guidelines
for the free-response questions in this exam.

AP[®] PHYSICS B
2012 INTERNATIONAL EXAM SCORING GUIDELINES

Question 1

15 points total

**Distribution
of points**

(a) 3 points

For work indicating use of conservation of energy

1 point

$$U_{g1} = K_2$$

$$mgh_1 = \frac{1}{2}mv_2^2$$

For a correct expression for determining the vertical drop distance

1 point

$$h = L - L\cos 60^\circ$$

$$h = 0.60 \text{ m} - (0.60 \text{ m})\cos 60^\circ$$

$$h = 0.30 \text{ m}$$

For substitution of a drop distance (other than 0.60 m) into a correct expression for the speed of the 0.66 kg ball just before the collision

$$v = \sqrt{2gh} = \sqrt{2(9.8 \text{ m/s}^2)(0.30 \text{ m})}$$

$$v = 2.4 \text{ m/s}$$

(b) 3 points

The speed immediately after the collision equals the horizontal speed of the 0.22 kg ball as it leaves the table, which is the horizontal distance it travels divided by the time it takes to fall.

For a correct expression for the time it takes the 0.22 kg ball to fall

1 point

$$\Delta y = \frac{1}{2}gt^2$$

$$t = \sqrt{2\Delta y/g}$$

$$t = \sqrt{2(1.2 \text{ m})/(9.8 \text{ m/s}^2)}$$

$$t = 0.49 \text{ s} \text{ (or } 0.50 \text{ s using } g = 10 \text{ m/s}^2 \text{)}$$

For consistent substitution of the time into a correct expression for the speed of the 0.22 kg ball after the collision

1 point

$$v_{0.22} = x/t = (1.4 \text{ m})/(0.49 \text{ s})$$

For the correct numerical value of the speed

1 point

$$v_{0.22} = 2.8 \text{ m/s} \text{ (or } 2.9 \text{ m/s using } g = 10 \text{ m/s}^2 \text{)}$$

(c) 3 points

For work indicating use of conservation of momentum

1 point

$$m_{0.66}v_{0.66i} = m_{0.66}v_{0.66f} + m_{0.22}v_{0.22f}$$

For consistent substitution of the answer from part (a) as $v_{0.66i}$ in a correct expression for

1 point

$$v_{0.66f}$$

$$v_{0.66f} = \frac{m_{0.66}v_{0.66i} - m_{0.22}v_{0.22f}}{m_{0.66}} = \frac{(0.66 \text{ kg})(2.4 \text{ m/s}) - (0.22 \text{ kg})(2.8 \text{ m/s})}{(0.66 \text{ kg})}$$

For the correct numerical value of the speed

1 point

$$v_{0.66f} = 1.5 \text{ m/s} \text{ (or } 1.4 \text{ m/s using } g = 10 \text{ m/s}^2 \text{)}$$

AP PHYSICS B
2012 INTERNATIONAL EXAM SCORING GUIDELINES

Question 1 (continued)

**Distribution
of points**

(d) 1 point

For indicating “To the right” as the direction of motion of the 0.66 kg ball after the collision 1 point

(e) 2 points

For an appropriate conservation of energy statement 1 point

$$K_1 = U_{g2}$$

$$\frac{1}{2}mv_{0.66f}^2 = mgh'$$

For consistent substitution of $v_{0.66f}$ from part (c) into a correct expression for h' 1 point

$$h' = \frac{v_{0.66f}^2}{2g} = \frac{(1.5 \text{ m/s})^2}{(2)(9.8 \text{ m/s}^2)}$$

$$h' = 0.11 \text{ m}$$

(f) 3 points

For any indication of comparing kinetic energies of the system before and after the collision 1 point

For calculating the two values of kinetic energy 1 point

$$K_i = \frac{1}{2}(0.66 \text{ kg})(2.4 \text{ m/s})^2 = 1.9 \text{ J}$$

$$K_f = \frac{1}{2}(0.66 \text{ kg})(1.5 \text{ m/s})^2 + \frac{1}{2}(0.22 \text{ kg})(2.8 \text{ m/s})^2 = 1.6 \text{ J}$$

For indication that the difference in the kinetic energies means an inelastic collision 1 point
All three points could be earned for indicating that the collision is elastic only if it is specifically stated that the difference in kinetic energies is not significant.

Alternate solution

Alternate points

For work indicating that the coefficient of elasticity must be calculated

1 point

For calculating the value of the coefficient of elasticity

1 point

$$e = \frac{|v_{0.22f} - v_{0.66f}|}{|v_{0.22i} - v_{0.66i}|}$$

$$e = \frac{|2.8 \text{ m/s} - 1.5 \text{ m/s}|}{|0 - 2.4 \text{ m/s}|}$$

$$e = 0.54$$

For indication that a coefficient of elasticity of less than one means an inelastic collision 1 point

AP[®] PHYSICS B
2012 INTERNATIONAL EXAM SCORING GUIDELINES

Question 2

15 points total

**Distribution
of points**

(a) 4 points

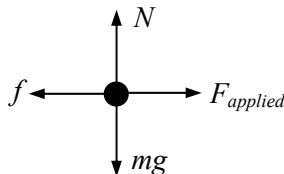

The line of action of each force vector must pass through the dot.
 For each correctly drawn and labeled force
 One earned point was deducted if any extraneous forces are present.

1 point each

(b) 3 points

To move the box at constant speed the applied force must equal the frictional force.

$$\sum F = F_{\text{applied}} - f = ma = 0$$

$$F_{\text{applied}} = f$$

For a correct expression relating the frictional and normal forces

$$f = \mu N$$

1 point

For a correct expression for the normal force

$$N = mg$$

$$f = \mu mg$$

1 point

For consistent substitution and evaluation

$$f = (0.20)(30 \text{ kg})(9.8 \text{ m/s}^2)$$

$$f = 58.8 \text{ N (or } 60 \text{ N using } g = 10 \text{ m/s}^2)$$

1 point

(c) 4 points

For correctly determining the distance between the box and the elevator at $t = 4 \text{ s}$

$$d = 16 \text{ m} - (1.2 \text{ m/s})(4 \text{ s}) = 11.2 \text{ m}$$

1 point

For consistent substitution into a correct kinematic equation to determine the box's acceleration

$$d = v_0 t + (1/2)at^2$$

$$a = 2(d - v_0 t)/t^2 = 2((11.2 \text{ m}) - (1.2 \text{ m/s})(5 \text{ s}))/ (5 \text{ s})^2 = 0.42 \text{ m/s}^2$$

Note: Students may also employ graphical methods to determine the acceleration.

For an application of Newton's second law to find the new applied force

$$F'_{\text{applied}} - f = ma$$

$$F'_{\text{applied}} = ma + f$$

1 point

For consistent substitution of values into Newton's second law

$$F'_{\text{applied}} = (30 \text{ kg})(0.42 \text{ m/s}^2) + 58.8 \text{ N}$$

$$F'_{\text{applied}} = 71.4 \text{ N (or } 72.6 \text{ N using } g = 10 \text{ m/s}^2)$$

1 point

AP PHYSICS B
2012 INTERNATIONAL EXAM SCORING GUIDELINES

Question 2 (continued)

**Distribution
of points**

(c) continued

Alternate solution

Alternate points

For correctly determining the distance between the box and the elevator at $t = 4$ s

1 point

$$d = 16 \text{ m} - (1.2 \text{ m/s})(4 \text{ s}) = 11.2 \text{ m}$$

For a correct application of kinematic equations with consistent substitutions to determine the final velocity of the box

1 point

$$d = \frac{1}{2}(v_0 + v)t$$

$$v = 2d/t - v_0 = 2(11.2 \text{ m})/(5 \text{ s}) - 1.2 \text{ m/s}$$

$$v = 3.3 \text{ m/s}$$

Note: Students may also employ graphical methods to determine the final velocity.

For a correct application of the work-energy theorem to find the net force

1 point

$$W = F_{net} d = \Delta K = \frac{1}{2}mv^2 - \frac{1}{2}mv_0^2$$

$$F_{net} = \frac{m(v^2 - v_0^2)}{2d} = \frac{(30 \text{ kg})(3.3^2 - 1.2^2) \text{ m}^2/\text{s}^2}{2(11.2 \text{ m})} = 13 \text{ N}$$

For using the vector addition of forces to determine the applied force

1 point

$$F'_{applied} - f = F_{net}$$

$$F'_{applied} = F_{net} + f$$

$$F'_{applied} = 13 \text{ N} + 60 \text{ N} = 73 \text{ N}$$

(d) 4 points

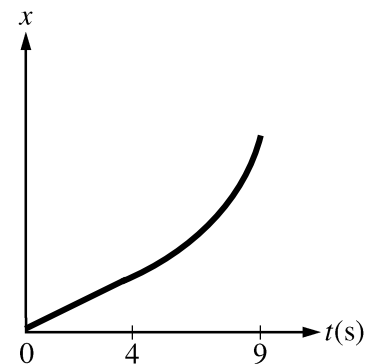
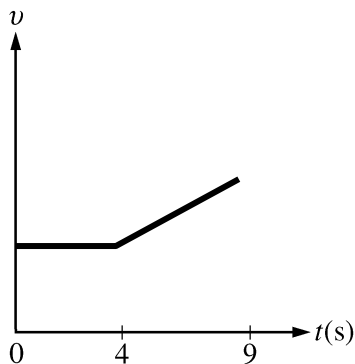
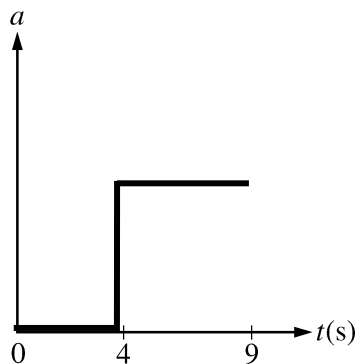

For indicating a zero initial acceleration

1 point

For showing zero acceleration until 4 s, then a change to a non-zero, positive constant until 9 s

1 point

For a velocity graph that is a non-zero, positive constant until 4 s, then linearly increasing until 9 s

1 point

For a distance graph that is linearly increasing until 4 s, then appropriately curved until 9 s

1 point

AP[®] PHYSICS B
2012 INTERNATIONAL EXAM SCORING GUIDELINES

Question 3

15 points total

**Distribution
of points**

(a)

i. 3 points

For indicating that the pressures on the two pistons are the same

1 point

$$P_A = P_B$$

$$F_A/A_A = F_B/A_B$$

$$F_B = F_A A_B/A_A = mg A_B/A_A$$

For correct substitutions

1 point

$$F_B = \frac{(1200 \text{ kg})(9.8 \text{ m/s}^2)\pi(0.10 \text{ m})^2}{\pi(0.30 \text{ m})^2}$$

For the correct answer

1 point

$$F_B = 1307 \text{ N} \quad (\text{or } 1333 \text{ N using } g = 10 \text{ m/s}^2)$$

ii. 2 points

For correct substitution into an expression indicating that the change in volume is equal for the two pistons

1 point

$$A_A d_A = A_B d_B$$

$$d_A = \frac{A_B d_B}{A_A} = \frac{\pi(0.10 \text{ m})^2(2.5 \text{ m})}{\pi(0.30 \text{ m})^2}$$

For the correct answer

1 point

$$d_A = 0.278 \text{ m}$$

(b) 2 points

For consistent substitution of force and distance into a correct expression for the work

1 point

$$W = F_B d_B$$

OR $W = F_A d_A$

$$W = (1307 \text{ N})(2.5 \text{ m})$$

OR $W = (1200 \text{ kg})(9.8 \text{ m/s}^2)(0.278 \text{ m})$

For a correct answer consistent with the substitutions

1 point

$$W = 3268 \text{ J}$$

OR $W = 3269 \text{ J}$

$$(\text{or } 3336 \text{ J using } g = 10 \text{ m/s}^2)$$

$$(\text{or } 3336 \text{ using } g = 10 \text{ m/s}^2)$$

**AP PHYSICS B
2012 INTERNATIONAL EXAM SCORING GUIDELINES**

Question 3 (continued)

**Distribution
of points**

(c) 2 points

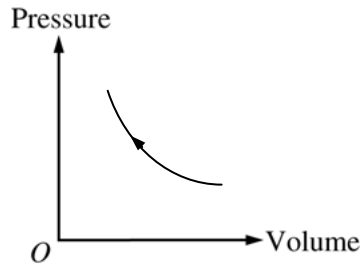

For a correctly drawn curved line

1 point

For an arrowhead indicating the correct direction of the process

1 point

(d)

i. 2 points

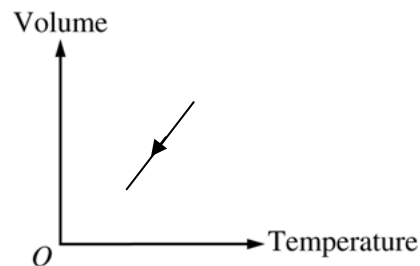

For a correct straight line

1 point

For an arrowhead indicating the correct direction of the process

1 point

ii. 3 points

For indicating that heat is removed from the gas

1 point

For a correct justification

2 points

For example: From the first law of thermodynamics $Q = \Delta U - W$. Since the compression is isobaric, the temperature decreases. The work done on the gas is positive and ΔU is negative, therefore the heat must be removed.

Units 1 point

For correct units on all numerical answers

1 point

AP[®] PHYSICS B
2012 INTERNATIONAL EXAM SCORING GUIDELINES

Question 4

15 points total

**Distribution
of points**

(a) 3 points

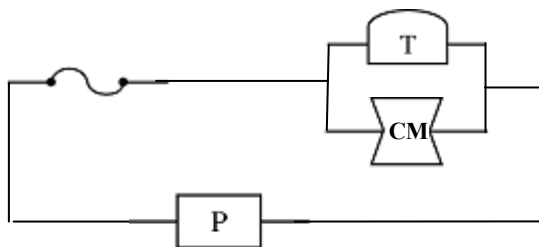

For having the toaster and coffeemaker in parallel	1 point
For including the fuse in series with the power supply	1 point
For a complete circuit with all elements labeled and no extra devices	1 point

(b) 3 points

For a correct expression showing the relationship between power and current $I = P/V$	1 point
--	---------

For calculating the current through each appliance (OR full credit could also be earned for calculating the total power)	1 point
--	---------

$I_{CM} = 300 \text{ W}/120 \text{ V} = 2.5 \text{ A}$
 $I_T = 1000 \text{ W}/120 \text{ V} = 8.3 \text{ A}$ OR $P_{total} = P_{CM} + P_T = 300 \text{ W} + 1000 \text{ W} = 1300 \text{ W}$
 $I_F = 2.5 \text{ A} + 8.3 \text{ A}$ OR $I_F = P_{total}/V = 1300 \text{ W}/120 \text{ V}$

For the correct answer $I_F = 10.8 \text{ A}$	1 point
--	---------

(c) 3 points

For a correct expression relating resistance and power, voltage or current (credit was not awarded for showing the same expression used in (b))	1 point
---	---------

$R = V/I$ OR $R = V^2/P$

For calculating the resistance of the coffeemaker	1 point
---	---------

$R_{CM} = 120 \text{ V}/2.5 \text{ A} = 48 \Omega$ OR $R_{CM} = (120 \text{ V})^2/300 \text{ W} = 48 \Omega$

For calculating the resistance of the toaster	1 point
---	---------

$R_T = 120 \text{ V}/8.33 \text{ A} = 14.4 \Omega$ OR $R_T = (120 \text{ V})^2/1000 \text{ W} = 14.4 \Omega$

AP PHYSICS B
2012 INTERNATIONAL EXAM SCORING GUIDELINES

Question 4 (continued)

**Distribution
of points**

(d) 2 points

For calculating either: 1 point

the maximum power that can be drawn by the circuit,

OR the maximum current for the hair dryer such that the fuse is not blown,

OR the maximum resistance for the hair dryer such that the fuse is not blown

Maximum power of circuit: $P = VI = 120 \text{ V} (20 \text{ A}) = 2400 \text{ W}$

Maximum current in hair dryer: $I_{HD} = 20 \text{ A} - 10.8 \text{ A} = 9.2 \text{ A}$

Maximum resistance of hair dryer: $R_{tot} = \frac{V}{I} = \frac{120 \text{ V}}{20 \text{ A}} = 6 \Omega$

$$\frac{1}{6 \Omega} = \frac{1}{14.4 \Omega} + \frac{1}{48 \Omega} + \frac{1}{R_{HD}}$$

$$R_{HD} = 13.1 \Omega$$

For calculating the maximum power of the hair dryer for using one of the quantities above 1 point

$$P_{HD} = 2400 \text{ W} - 1300 \text{ W} = 1100 \text{ W}$$

$$\text{OR } P_{HD} = (9.2 \text{ A})(120 \text{ V}) = 1100 \text{ W}$$

$$\text{OR } P_{HD} = V^2/R = (120 \text{ V})^2/13.1 \Omega = 1100 \text{ W}$$

(e) 3 points

For indicating “Yes” (the two original appliances can be operated in series without blowing the fuse) 1 point

For indicating that the equivalent resistance of the series circuit is greater than the equivalent resistance of the parallel circuit 1 point

For indicating that the current is less than 20 A with correct reasoning 1 point

Note: The last two points were only received if the correct answer was given

Units 1 point

For correct units on all numerical answers, parts (b), (c), (d) 1 point

AP[®] PHYSICS B
2012 INTERNATIONAL EXAM SCORING GUIDELINES

Question 5

10 points total

**Distribution
of points**

(a) 2 points

For any indication of counting the number of fringes between two ruler values, then dividing the ruler distance by the number of fringes 1 point

For applying this concept with appropriate numbers, obtaining an answer in the range $1.1 \text{ mm} \leq z \leq 1.3 \text{ mm}$ 1 point

For example: There are 9 complete fringes (light plus dark area) between 0.6 and 11.1 mm

$$z = (11.1 \text{ mm} - 0.6 \text{ mm})/9 = (10.5 \text{ mm})/9$$

$$z = 1.17 \text{ mm}$$

(b) 3 points

For using the appropriate expression for the position of a maxima 1 point

$$x_m = m\lambda L/d$$

For indicating that the fringe spacing is the difference between the positions of two adjacent maxima 1 point

$$x_{m+1} - x_m = (m + 1 - m)\lambda L/d = \lambda L/d \quad (m = 1 \text{ can be implied})$$

Solving for the slit spacing:

$$d = \lambda L/z$$

For substituting λ , L , and the value of z from part (a) 1 point

$$d = \lambda L/z = (670 \text{ nm})(1.5 \text{ m})/(1.17 \text{ mm})$$

$$d = 0.859 \text{ mm}$$

Note: Students who correctly applied the equation $m\lambda = d \sin\theta$ received full credit. In addition, students who correctly used the Pythagorean theorem to calculate the path length difference for a specific maximum and set it equal to $m\lambda$, also received full credit.

(c) 3 points

For applying the equation for fringe spacing from (b) to the new situation 1 point

$$\lambda_u = z_u d/L$$

For a reasonable value for the new fringe spacing, consistent with the method in part (a) 1 point

$$z_u = 1.00 \text{ mm}$$

For substituting the value of d from part (b) 1 point

$$\lambda_u = (1.00 \text{ mm})(0.859 \text{ mm})/(1.5 \text{ m})$$

$$\lambda_u = 573 \text{ nm}$$

AP PHYSICS B
2012 INTERNATIONAL EXAM SCORING GUIDELINES

Question 5 (continued)

**Distribution
of points**

(c) (continued)

Alternate Solution

Alternate Points

For using a correct relationship between the initial fringe spacing and wavelength and the second fringe spacing and wavelength 1 point

$$z/z_u = \lambda/\lambda_u$$

$$\lambda_u = z_u \lambda / z$$

For a reasonable value for the new fringe spacing

1 point

$$z_u = 1.00 \text{ mm}$$

For substituting the value of z from part (a)

1 point

$$\lambda_u = (1.00 \text{ mm})(670 \text{ nm})/(1.17 \text{ mm})$$

$$\lambda_u = 573 \text{ nm}$$

(d) 2 points

$$\% \text{ error} = \frac{\text{experimental value} - \text{accepted value}}{\text{accepted value}}$$

For substituting 530 nm for the accepted value into a correct expression for the percent error 1 point

For substituting the answer from part (c) for the experimental value 1 point

$$\% \text{ error} = \frac{573 \text{ nm} - 530 \text{ nm}}{530 \text{ nm}}$$

$$\% \text{ error} = 8.11\%$$

AP[®] PHYSICS B
2012 INTERNATIONAL EXAM SCORING GUIDELINES

Question 6

10 points total

**Distribution
of points**

(a)

(i) 2 points

For using the given equation for wavelength with $n = 1$

1 point

$$\lambda = 2L/n$$

$$\lambda_1 = 2(1.7 \times 10^{-10} \text{ m})/1$$

For the correct answer with units

1 point

$$\lambda_1 = 3.4 \times 10^{-10} \text{ m}$$

Note: Full credit was awarded for saying $\lambda_1 = 2L$

(ii) 1 point

$$\lambda_2 = 2(1.7 \times 10^{-10} \text{ m})/2$$

For the correct answer with units

1 point

$$\lambda_2 = 1.7 \times 10^{-10} \text{ m}$$

Note: Full credit was awarded for saying that $\lambda_2 = L$

(iii) 2 points

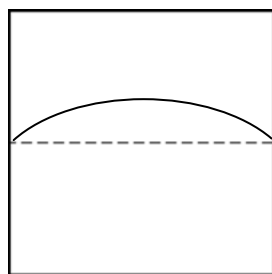

Fundamental

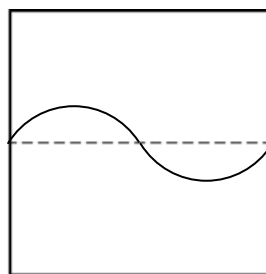

First Overtone

For the correct fundamental wave pattern, including being sinusoidal in shape and having a non-zero slope at the endpoints

1 point

For the correct first overtone wave pattern, including being sinusoidal in shape and having a non-zero slope at the endpoints

1 point

Note: No points were awarded if patterns shown above were drawn in wrong boxes.

AP PHYSICS B
2012 INTERNATIONAL EXAM SCORING GUIDELINES

Question 6 (continued)

	Distribution of points
(b) 2 points	
For using the expression for de Broglie wavelength with the substitution $p = m_e v$ $\lambda = h/p = h/m_e v$	1 point
For substituting using the given equation relating wavelength and n $v_n = nh/2m_e L$	1 point
(c) 3 points	
$K_1 = \frac{1}{2} m_e v_1^2$ OR $K_1 = \frac{p_1^2}{2m_e}$	
For substituting the expression for v with $n = 1$ into a correct expression for the kinetic energy	1 point
$K_1 = \frac{1}{2} m_e \left(\frac{h}{2m_e L} \right)^2 = \frac{h^2}{8m_e L^2}$	
For substituting a value for h with units consistent with those in the answer	1 point
For substituting m_e and L correctly	1 point
$K_1 = \frac{(6.63 \times 10^{-34} \text{ J}\cdot\text{s})^2}{8(9.11 \times 10^{-31} \text{ kg})(1.7 \times 10^{-10} \text{ m})^2}$	
$K_1 = 2.09 \times 10^{-18} \text{ J}$ (or 13.0 eV)	

GO ON TO THE NEXT PAGE.

Scoring Worksheet

The following provides a worksheet and conversion table used for calculating a composite score of the exam.

2012 AP Physics B Scoring Worksheet

Section I: Multiple Choice

$$\frac{\text{Number Correct}}{\text{(out of 69*)}} \times 1.3043 = \frac{\text{Weighted Section I Score}}{\text{(Do not round)}}$$

Section II: Free Response

$$\text{Question 1 } \frac{\text{_____}}{\text{(out of 15)}} \times 1.1250 = \frac{\text{_____}}{\text{(Do not round)}}$$

$$\text{Question 2 } \frac{\text{_____}}{\text{(out of 15)}} \times 1.1250 = \frac{\text{_____}}{\text{(Do not round)}}$$

$$\text{Question 3 } \frac{\text{_____}}{\text{(out of 15)}} \times 1.1250 = \frac{\text{_____}}{\text{(Do not round)}}$$

$$\text{Question 4 } \frac{\text{_____}}{\text{(out of 15)}} \times 1.1250 = \frac{\text{_____}}{\text{(Do not round)}}$$

$$\text{Question 5 } \frac{\text{_____}}{\text{(out of 10)}} \times 1.1250 = \frac{\text{_____}}{\text{(Do not round)}}$$

$$\text{Question 6 } \frac{\text{_____}}{\text{(out of 10)}} \times 1.1250 = \frac{\text{_____}}{\text{(Do not round)}}$$

$$\text{Sum} = \frac{\text{_____}}{\text{Weighted Section II Score (Do not round)}}$$

Composite Score

$$\frac{\text{Weighted Section I Score}}{\text{_____}} + \frac{\text{Weighted Section II Score}}{\text{_____}} = \frac{\text{Composite Score (Round to nearest whole number)}}{\text{_____}}$$

AP Score Conversion Chart
Physics B

Composite Score Range	AP Score
129-180	5
100-128	4
71-99	3
52-70	2
0-51	1

*Although 70 multiple-choice items were administered in Section I, item 26 was not used in scoring.

AP Physics B

The College Board

The College Board is a mission-driven not-for-profit organization that connects students to college success and opportunity. Founded in 1900, the College Board was created to expand access to higher education. Today, the membership association is made up of over 6,000 of the world's leading educational institutions and is dedicated to promoting excellence and equity in education. Each year, the College Board helps more than seven million students prepare for a successful transition to college through programs and services in college readiness and college success — including the SAT[®] and the Advanced Placement Program[®]. The organization also serves the education community through research and advocacy on behalf of students, educators, and schools. The College Board is committed to the principles of excellence and equity, and that commitment is embodied in all of its programs, services, activities, and concerns.

Visit the College Board on the Web: www.collegeboard.org.