

The Basics of Technical Drawing (Drafting)

Creating technical drawings is a time-honored art form which is used in all fields of Engineering (Mechanical, Civil, Architectural, Electrical, Aerospace, etc.).

The main purpose of technical drawings is to communicate specific information to other technical people (i.e. engineers, machinists, etc).

Technical drawings give all of the information needed to make the product and being accurate in that information is the main goal. Engineers are very picky about their drawings and must pay attention to detail.

The Basics of Technical Drawing (Drafting)

Before starting your technical drawing, you should plan how you are going to make best use of the space. It is important to think about the number of views your drawing will have and how much space you will use of the paper.

- Try to make maximum use of the available space.
- If a view has lots of detail, try and make that view as large as possible.
If necessary, draw that view on a separate sheet.
- If you intend to add dimensions to the drawing, remember to leave enough space around the drawing for them to be added later.

The Basics of Technical Drawing (Drafting)

Basic Equipment (see booklet)



The Basics of Technical Drawing (Drafting)

The layout of a Technical Drawing

It is important that you follow some simple rules when producing a technical drawing.

All engineering drawings should feature an **information box**.

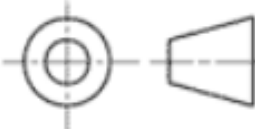
| | |
|---|---|
| TITLE WHEEL BEARING | |
| NAME John Smith | CHECKED <i>John</i> |
| VERSION 1.1 | DATE 16.10.98 |
| NO NEED TO MEASURE - ALL MEASUREMENTS IN MM | SCALE 1:1 |
| ITI ENGINEERING |  |

The Basics of Technical Drawing (Drafting)

Common information recorded on an engineering drawing

TITLE - The title of the drawing.

NAME - The name of the person who produced the drawing.

DATE - The date the drawing was created or amended on.

COMPANY NAME - Many CAD drawings may be distributed outside the company so the company name is usually added to identify the source.

SCALE - The scale of the drawing. Large parts won't fit on paper so the scale provides a quick guide to the final size of the product.

VERSION - Many drawings will get updated over the period of the parts life. Giving each drawing a version number helps people identify if they are using a recent version.

CHECKED - In many engineering firms, drawings are checked by a second person before they are sent to manufacture to identify any potential problems.

The Basics of Technical Drawing (Drafting)

Lines and line styles

Lines on a technical drawing signify more than just the geometry of the object and it is important that you use the appropriate line types.

Line Thickness

For most technical drawings you will require two thicknesses.

a) a thick and



b) a thin line.



The general recommendation are that thick lines are ***twice as thick*** as thin lines.

A thick continuous line is used for visible edges and outlines.

A thin line is used for hatching, leader lines, short centre lines, dimensions and projections.

The Basics of Technical Drawing (Drafting)

Line Styles

Other line styles used to clarify important features on drawings are:

Thin chain lines are a common feature on engineering drawings used to indicate centre lines. Centre lines are used to identify the centre of a circle, cylindrical features, or a line of symmetry. Centre lines will be covered in a little bit more detail later in this tutorial.



Dashed lines are used to show important hidden detail for example wall thickness and holes..



The Basics of Technical Drawing (Drafting)

A **dimensioned drawing** should provide all the information necessary for a finished product or part to be manufactured.

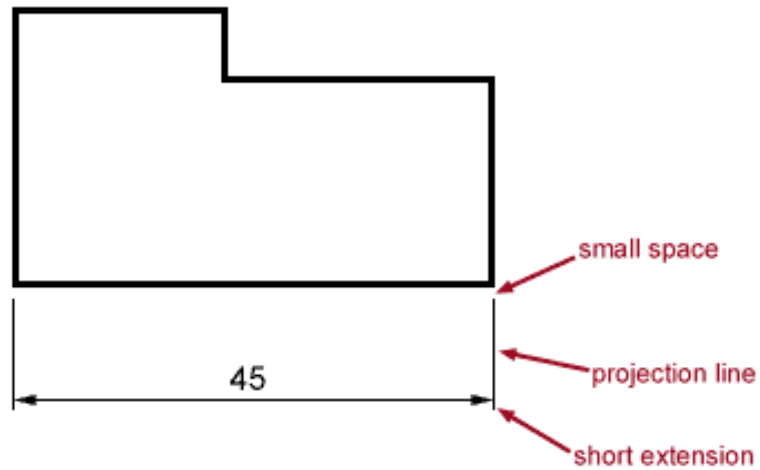

The Basics of Technical Drawing (Drafting)

Dimensions are always drawn using continuous thin lines.

Two **projection lines** indicate where the dimension starts and finishes.

Projection lines ...

- a) do not touch the object and
- b) are drawn perpendicular to the element you are dimensioning.

In general units can be omitted from dimensions if a statement of the units is included on your drawing. The general convention is to dimension in mm's.

Dimensions less than 1 should have a leading zero.

(For example **.35** should be written as **0.35**)

The Basics of Technical Drawing (Drafting)

Lettering

All notes and dimensions should be clear and easy to read. In general all notes should be written in capital letters to aid legibility.

All lettering should be of the same size and preferably no smaller than 3mm.

ABCDEFGHIJKLMNOPQRSTUVWXYZ
1234567890

The Basics of Technical Drawing (Drafting)

Parallel Dimensioning

Parallel dimensioning consists of several dimensions originating from one projection line.

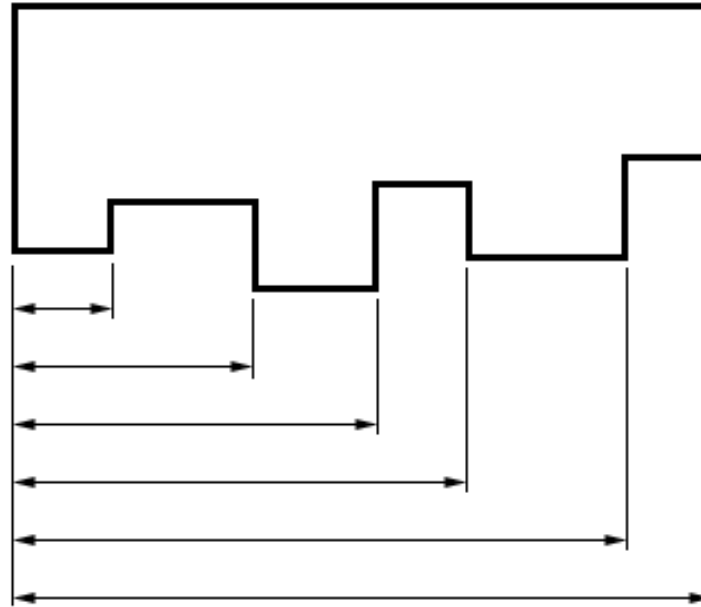

The Basics of Technical Drawing (Drafting)

Superimposed Running Dimensions

Superimposed running dimensioning simplifies parallel dimensions in order to reduce the space used on a drawing.

The common origin for the dimension lines is indicated by a small circle at the intersection of the first dimension and the projection line. In general all other dimension lines are broken.

The dimension note can a
projection line

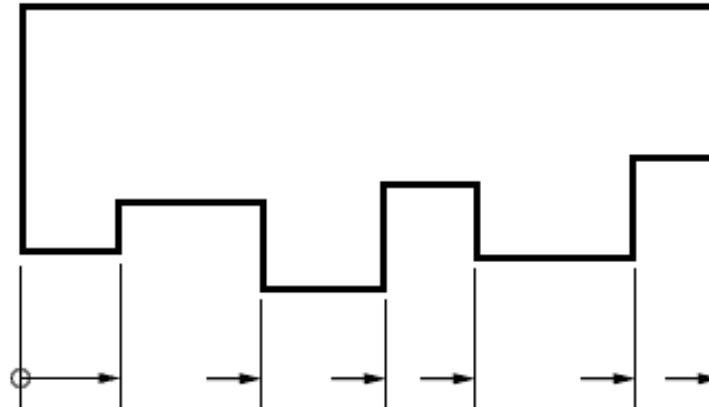

The Basics of Technical Drawing (Drafting)

Chain Dimensioning

Chains of dimension should only be used if the function of the object won't be affected by the accumulation of the tolerances.

A **tolerance** is an indication of the accuracy the product has to be made to.

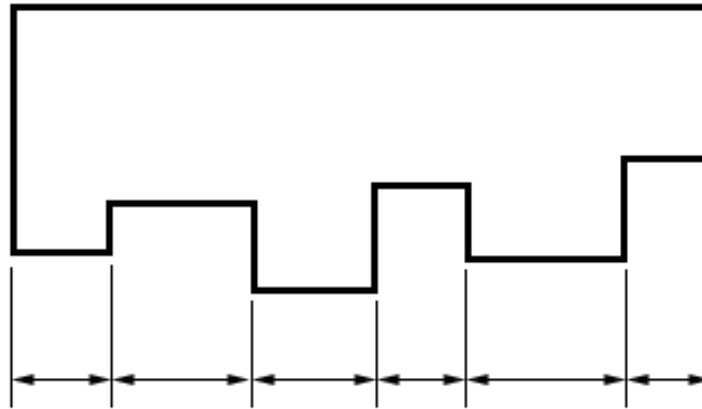

The Basics of Technical Drawing (Drafting)

Combined Dimensions

A combined dimension uses both chain dimensioning and parallel dimensioning.

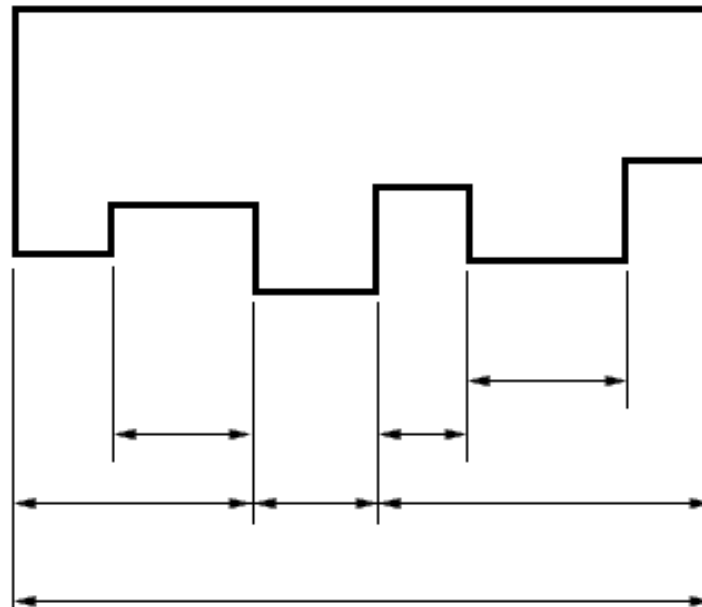

The Basics of Technical Drawing (Drafting)

Simplified dimensioning by co-ordinates

It is also possible to simplify co-ordinate dimensions by using a table to identify features and positions.

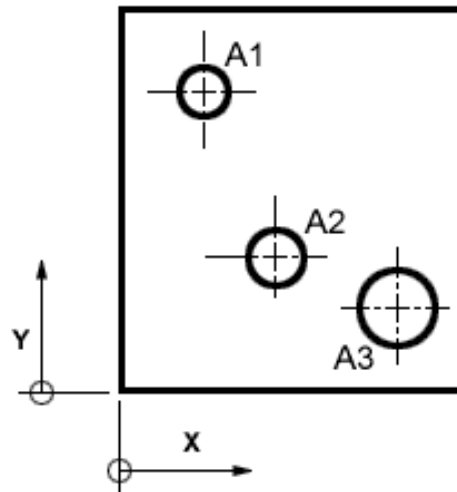

| HOLE | X | Y | ϕ |
|------|-----|----|----|
| A1 | 100 | 25 | 25 |
| A2 | 50 | 40 | 15 |
| A3 | 100 | 20 | 15 |

The Basics of Technical Drawing (Drafting)

Dimensioning Small Features

When dimensioning small features, placing the dimension arrow between projection lines may create a drawing which is difficult to read.

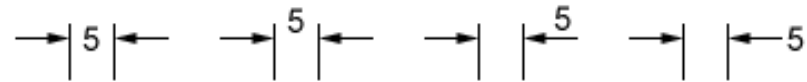

In order to clarify dimensions on small features any of the methods can be used.

The Basics of Technical Drawing (Drafting)

Dimensioning circles

All dimensions of circles are preceded by this symbol ...



There are several conventions used for dimensioning circles:

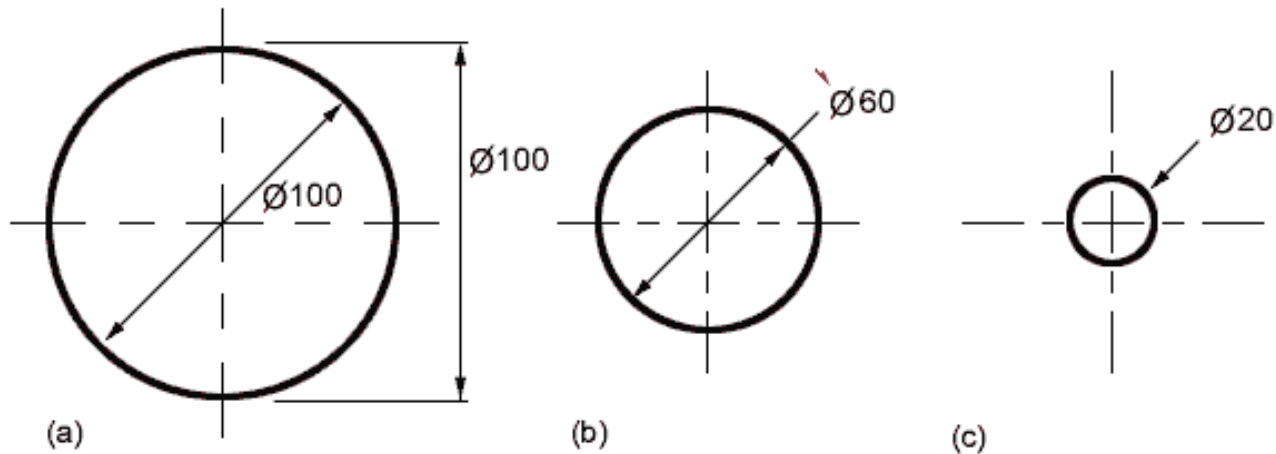

The Basics of Technical Drawing (Drafting)

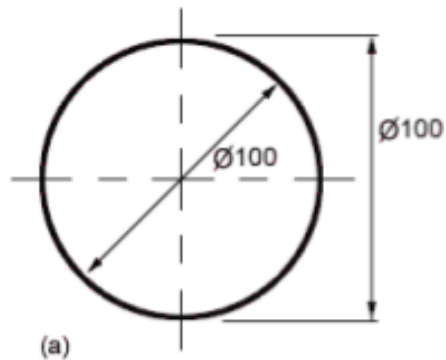

(a) shows two common methods of dimensioning a circle. One method dimensions the circle between two lines projected from two diametrically opposite points. The second method dimensions the circle internally. This is the least used method.

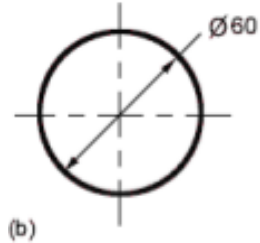

(b) this method is used when the circle is too small for the dimension to be easily read if it was placed inside the circle. A leader line is used to display the dimension.

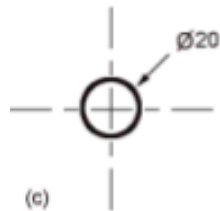

(c) this method dimensions the circle from outside the circle using an arrow which points directly towards the centre of the circle.

The Basics of Technical Drawing (Drafting)

Dimensioning by Co-ordinates

Two sets of superimposed running dimensions running at right angles can be used with any features which need their centre points defined, such as holes.

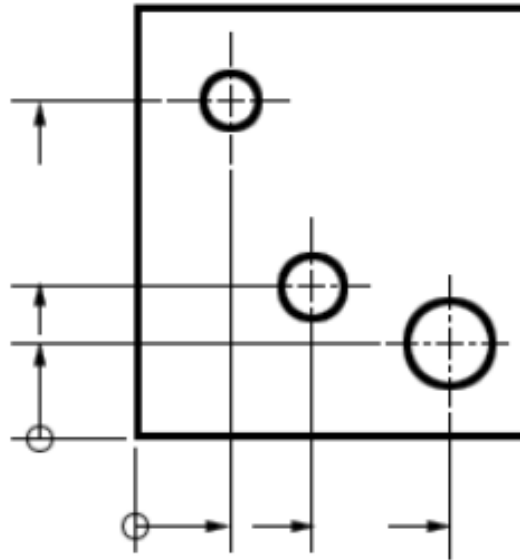

The Basics of Technical Drawing (Drafting)

Dimensioning Holes

When dimensioning holes the method of manufacture is not specified unless they necessary for the function of the product. The word hole doesn't have to be added unless it is considered necessary.

The depth of the hole is usually indicated if it isn't indicated on another view. The depth of the hole refers to the depth of the cylindrical portion of the hole and not the bit of the hole caused by the tip of the drill.

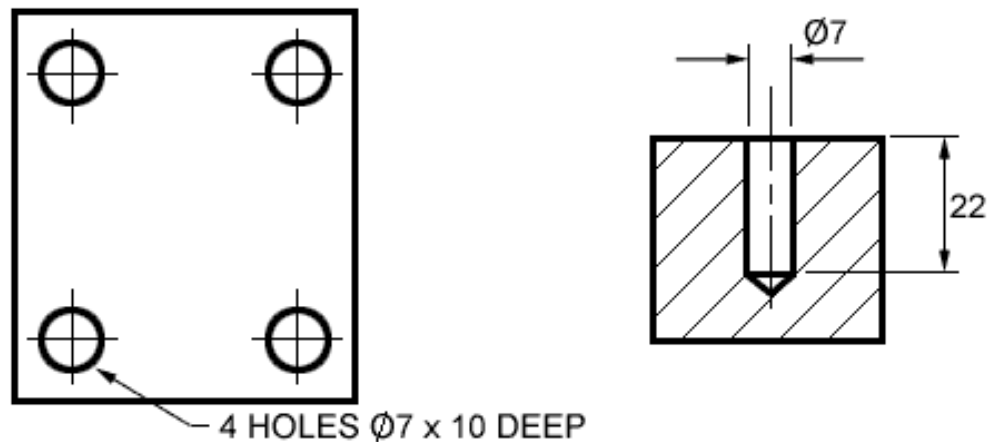

The Basics of Technical Drawing (Drafting)

Dimensioning Radii

All radial dimensions are preceded by the capital R. All dimension arrows and lines should be drawn perpendicular to the radius so that the line passes through the centre of the arc. All dimensions should only have one arrowhead which should point to the line being dimensioned. There are two methods for dimensioning radii.

(a) shows a radius dimensioned with the centre of the radius located on the drawing.

(b) shows how to dimension radii which do not need their centres locating.

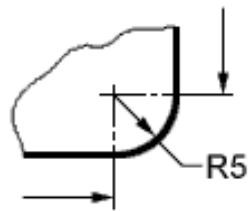

(a)

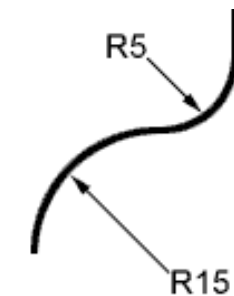

(b)

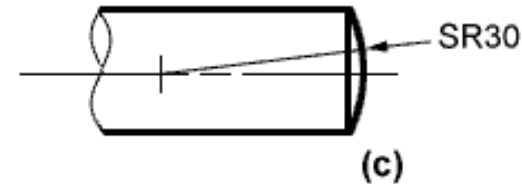

(c)

The Basics of Technical Drawing (Drafting)

Spherical dimensions

The radius of a spherical surface (i.e. the top of a drawing pin) when dimensioned should have an SR before the size to indicate the type of surface.

The Basics of Technical Drawing (Drafting)

Tolerancing

It is not possible in practice to manufacture products to the exact figures displayed on an engineering drawing. The accuracy depends largely on the manufacturing process used and the care taken to manufacture a product. A tolerance value shows the manufacturing department the maximum permissible variation from the dimension.

Each dimension on a drawing must include a tolerance value.

This can appear either as:

- a) a general tolerance value applicable to several dimensions or (i.e. a note specifying that the General Tolerance ± 0.5 mm).
- b) a tolerance specific to that dimension

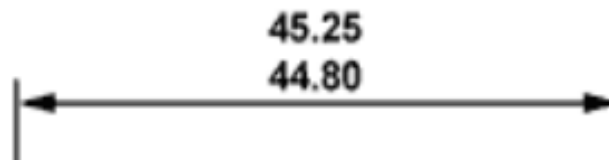

Note : *the larger size limit is placed above the lower limit*

The Basics of Technical Drawing (Drafting)

Orthographic projection:

The aim of an engineering drawing is to convey all the necessary information of how to make the part to the manufacturing department.

For most parts, the information cannot be conveyed in a single view. Rather than using several sheets of paper with different views of the part, several views can be combined on a single drawing.

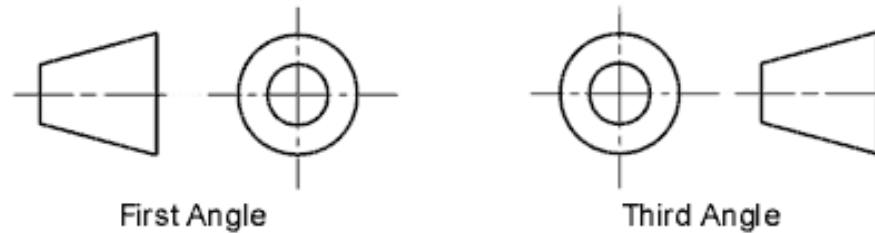

The Basics of Technical Drawing (Drafting)

Sectioning

Sections and sectional views are used to show hidden detail more clearly. They are created by using a cutting plane to cut the object.

A section is a view of no thickness and shows the outline of the object at the cutting plane. Visible outlines beyond the cutting plane are not drawn.

A sectional view, displays the outline of the cutting plane and all visible outlines which can be seen beyond the cutting plane. The diagram below shows a sectional view, and how a cutting plane works.

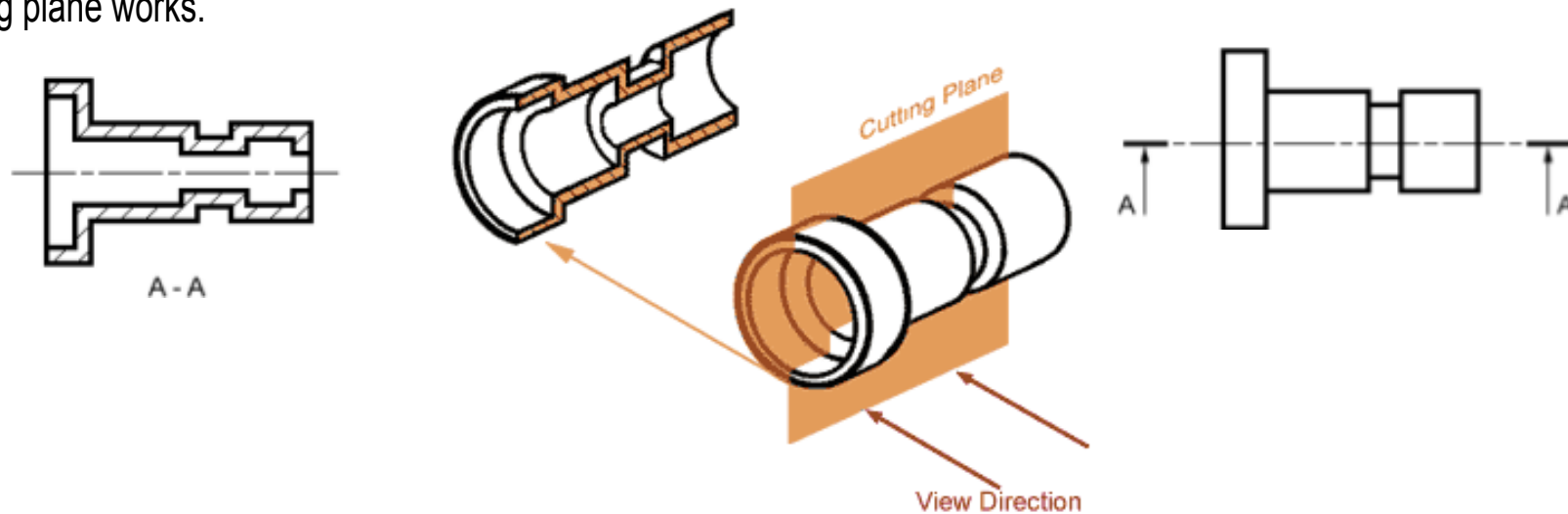

The Basics of Technical Drawing (Drafting)

Hatching

On sections and sectional views solid area should be hatched to indicate this fact. Hatching is drawn with a thin continuous line, equally spaced (preferably about 4mm apart, though never less than 1mm) and preferably at an angle of 45 degrees.

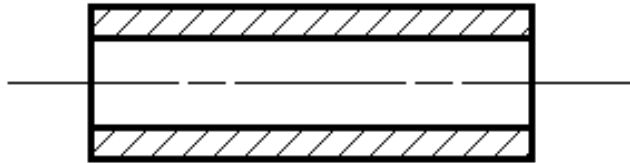

Hatching a single object

When you are hatching an object, but the objects has areas that are separated, all areas of the object should be hatched in the same direction and with the same spacing.

The Basics of Technical Drawing (Drafting)

Hatching Adjacent objects

When hatching assembled parts, the direction of the hatching should ideally be reversed on adjacent parts. If more than two parts are adjacent, then the hatching should be staggered to emphasise the fact that these parts are separate.

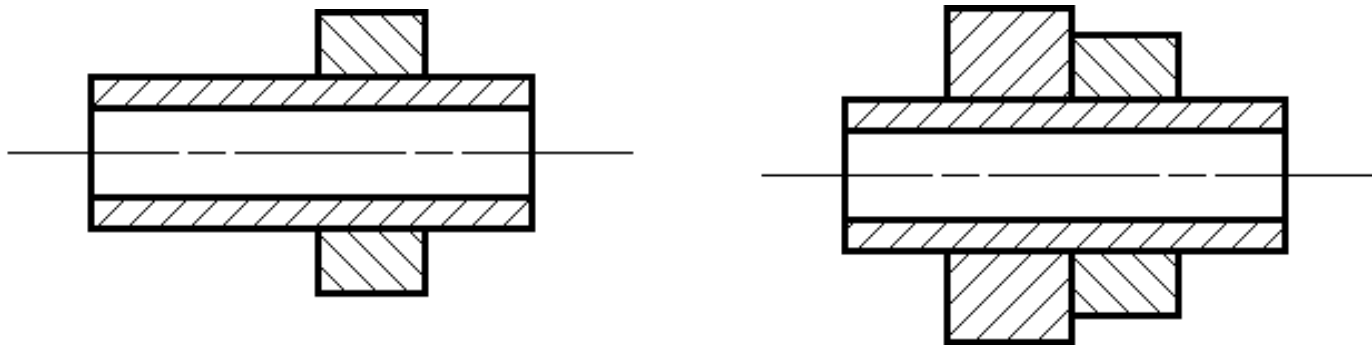

The Basics of Technical Drawing (Drafting)

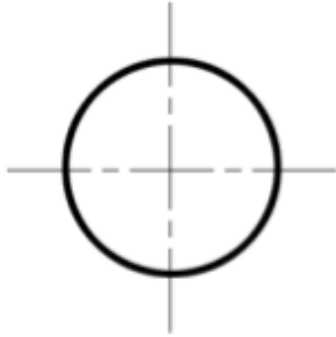

Hatching thin materials

Sometimes, it is difficult to hatch very thin sections. To emphasise solid wall the walls can be filled in. This should only be used when the wall thickness size is less than 1mm

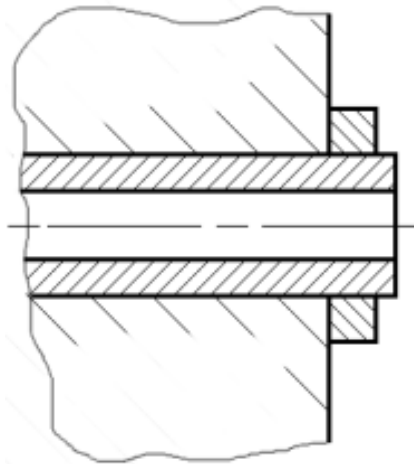

Hatching large areas

When hatching large areas in order to aid readability, the hatching can be limited to the area near the edges of the part.

The Basics of Technical Drawing (Drafting)

Drawing Conventions

Threaded parts

Threads are drawn with thin lines as shown in this illustration. When drawn from end-on, a threaded section is indicated by a broken circle drawn using a thin line.

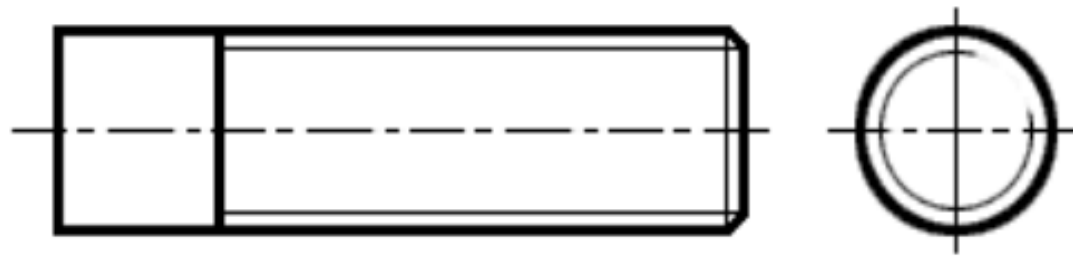

The Basics of Technical Drawing (Drafting)

Threaded parts

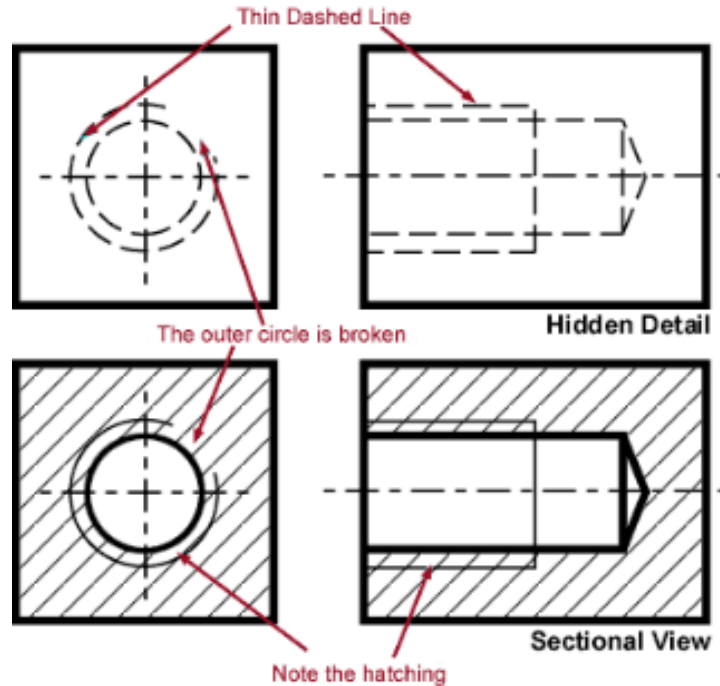

Frequently a threaded section will need to be shown inside a part.

The two illustrations to the left demonstrate two methods of drawing a threaded section. Note the conventions. The hidden detail is drawn as a thin dashed line.

The sectional view uses both thick and thin line with the hatching carrying on to the very edges of the object.